

SERVICE MANUAL

2015



ZR/XF/M
4000/6000/8000



SHARE OUR PASSION.™



www.arcticcat.com

FOREWORD

This Arctic Cat Service Manual contains service and maintenance information for certain Model Year 2015 Arctic Cat Snowmobiles (see cover). The manual is designed to aid service personnel in service-oriented applications.

This manual is divided into sections. The sections cover specific snowmobile components or systems and, in addition to the standard service procedures, includes assembling, disassembling, and inspecting instructions. When using this manual as a guide, the technician should use discretion as to how much disassembly is needed to correct any given condition.

The service technician should become familiar with the operation and construction of the components or systems by carefully studying the complete manual. This will assist the service technician in becoming more aware of and efficient with servicing procedures. Such efficiency not only helps build consumer confidence but also saves time and labor.

All Arctic Cat publications and snowmobile decals display the words Warning, Caution, and Note to emphasize important information. The symbol  **WARNING** identifies personal safety-related information. Be sure to follow the directive because it deals with the possibility of severe personal injury or even death. A **CAUTION** identifies unsafe practices which may result in snowmobile-related damage. Follow the directive because it deals with the possibility of damaging part or parts of the snowmobile. The symbol  **NOTE:** identifies supplementary information worthy of particular attention.

At the time of publication, all information, photographs, and illustrations were technically correct. Some photographs and illustrations used in this manual are used for clarity purposes only and are not designed to depict actual conditions. Because Arctic Cat Inc. constantly refines and improves its products, no retroactive obligation is incurred.

All materials and specifications are subject to change without notice.

Keep this manual accessible in the shop area for reference.

**Product Service and Warranty Department
Arctic Cat Inc.**



TABLE OF CONTENTS

General Information	2	Fuel Systems	118
Snowmobile Identification	2	EFI System	118
Recommended Gasoline and Oil	2	Individual Components	118
Engine Break-In	2	Self-Diagnostic System/Codes (4000)	122
Drive Belt Break-In	3	Self-Diagnostic System/Codes (6000)	122
Genuine Parts	3	Self-Diagnostic System/Codes (8000)	122
Varying Altitude Operation	3	Fuel Pressure Regulator	123
Preparation For Storage	4	Throttle Body Assembly	123
Preparation After Storage	5	Throttle Cable	124
After Break-In Checkup/Checklist	5	Fuel Filter (6000)	124
Engine Specifications	7	Fuel Pump	125
Crankshaft Runout/Repair Specifications	7	Troubleshooting	127
Arctic Power Valve (APV) System Specifications	8	Oil-Injection Pump (4000/8000)	128
Electrical Specifications	9	Electric Oil Pump (6000)	129
Drive System Specifications	10	Gas Tank	130
Drive Clutch/Driven Clutch-Related Specifications	10	Electrical Systems	132
Drive System Components	10	Ignition System	132
Chain Case Performance Calibrations	11	Throttle Position Sensor	132
Track Specifications	13	Electrical Resistance Tests	134
Suspension Specifications	13	Testing Electric Oil Pump (6000)	136
Torque Conversions	13	Testing Voltage Regulator	136
Torque Specifications	14	Chassis Control Unit (CCU)/Codes (4000)	137
Steering and Body	15	Testing Oil Level Sensor	137
Steering Post (ZR/XF)	15	Testing Fuel Gauge Sender	138
Ski	19	Emergency Stop Switch	138
Ski Wear Bar	20	Starter Relay Solenoid	138
Spindle	20	Fuse	139
Steering Tie Rod	21	Ignition Switch	139
Ski Alignment	22	Starter Motor	139
A-Arms	24	Troubleshooting Electric Start	143
Ski Shock Absorber	25	Ignition Timing	143
Sway Bar (ZR/XF)	25	Brakelight Switch	144
Front Bumper	26	Headlight Dimmer Switch	144
Seat Assembly (ZR/XF/M STD)	26	Testing Handlebar Warmer Elements	145
Seat Assembly (M Sno Pro/HCR/LTD)	26	Testing Thumb Warmer Element	145
Taillight/Brakelight Assembly	27	Testing Handlebar Warmer/Thumb Warmer Switch	145
Rear Bumper/Snowflap	27	Testing Speedometer Sensor	146
Windshield/Console/Headlight	28	Testing Shift Switch	146
Headlight Bulb	29	Testing Servomotor/Potentiometer	146
Adjusting Headlight Aim	29	Troubleshooting Servomotor	148
Engine	30	Voltage/Resistance Chart - Air Temperature (8000)	150
Engine Removing/Installing - 4000	30	Voltage/Resistance Chart - Air Temperature (6000)	150
Assembly Schematic - 4000	34	Voltage/Resistance Chart - Coolant Temperature	151
Engine Removing/Installing - 6000	36	Drive Train/Track/Brake Systems	152
Assembly Schematic - 6000	42	Drive Belt	152
Engine Removing/Installing - 8000	44	Drive Clutch	153
Assembly Schematic - 8000	50	Driven Clutch	154
Engine Servicing - 4000	52	Drive Clutch/Driven Clutch	159
Engine Servicing - 6000	67	Drive Train	160
Engine Servicing - 8000	81	Drive Sprockets	166
Troubleshooting Engine	98	Track Tension	168
Engine-Related Items	100	Track Alignment	168
Water Pump - 4000	100	Brake System	169
Water Pump - 6000	103	Brake Lever/Master Cylinder Assembly	174
Water Pump - 8000	106	Troubleshooting Hydraulic Brake System	175
Pressure Testing Engine	109	Troubleshooting Track	176
Liquid Cooling System	109	Troubleshooting Drive Clutch/Driven Clutch	177
Cooling System Schematic	110	Suspension	178
Recoil Starter	111	Suspension Setup Basics	178
Arctic Power Valve (APV) System	112	Servicing Suspension	183
Exhaust Controlled Timing (ECT) System	116	Wiring Diagrams	198

General Information

■NOTE: General specifications for each 2015 Arctic Cat Snowmobile can be accessed from the Arctic Cat Cat Tracker Dealer Communication System online.

■NOTE: Some illustrations and photographs used in this section are used for clarity purposes only and are not designed to depict actual conditions.

Snowmobile Identification

The Arctic Cat Snowmobile has two important identification numbers. The Vehicle Identification Number (VIN) is stamped into the tunnel near the right-side footrest. The decal also displays pertinent production information. The Engine Serial Number (ESN) is stamped into the crankcase of the engine.

These numbers are required to complete warranty claims properly. No warranty will be allowed by Arctic Cat if the engine serial number or VIN is removed or mutilated in any way.

Recommended Gasoline and Oil

CAUTION

Do not use white gas or gasoline containing methanol. Only Arctic Cat approved gasoline additives should be used.

RECOMMENDED GASOLINE

6000/8000

The recommended gasoline to use is 91 octane (minimum).

■NOTE: If a situation arises in which 91 octane gasoline is not available, 87 octane gasoline can be substituted; however, do not prolong the usage of 87 octane gasoline as it will cause poor engine performance.

In many areas, oxygenates are added to the gasoline. Oxygenated gasolines containing up to 10% ethanol are acceptable gasolines.

4000

The recommended gasoline to use is 87 octane regular unleaded. In many areas, oxygenates are added to the gasoline. Oxygenated gasolines containing up to 10% ethanol are acceptable gasolines.

When using ethanol blended gasoline, it is not necessary to add a gasoline antifreeze since ethanol will prevent the accumulation of moisture in the fuel system.

RECOMMENDED OIL

CAUTION

Any oil used in place of the recommended oil may cause serious damage.

The recommended oil to use in the oil-injection system is either Arctic Cat C-Tec2 for the 6000 or Arctic Cat APV Synthetic 2-Cycle Oil for the 4000/8000. These oils are specially formulated to be used either as an injection oil or as a pre-mix oil (for break-in) and meets all of the lubrication requirements of the Arctic Cat snowmobile engine.

CAUTION

Any oil used in place of the recommended oil could cause serious engine damage.

Engine Break-In

4000/8000

The Arctic Cat engine (when new or rebuilt) requires a short break-in period before the engine is subjected to heavy load conditions. Arctic Cat requires that the first tankful of fuel be premixed at a 100:1 ratio in all oil-injection models.

CAUTION

DO NOT exceed the one (1) tankful limitation of a 100:1 gas/oil break-in mixture. Continuous use of a gas/oil mixture could cause spark plug fouling and excessive carbon buildup.

During the break-in period, a maximum of 1/2 throttle is recommended; however, brief full-throttle accelerations and variations in driving speeds contribute to good engine break-in.

6000

The Arctic Cat engine (when new or rebuilt) requires a short break-in period before the engine is subjected to heavy load conditions.

Premixing fuel and oil during the break in period is not required. With the oil delivery control strategy of the electronic oil pump, the pump will automatically compensate and deliver a richer fuel-to-oil ratio during the engine break-in period.

Some customers may choose to pre-mix the first tank and if this is the case, a pre-mix ratio of 100:1 is acceptable. A pre-mix ratio of 100:1 combined with the richer fuel/oil delivered from the electronic oil pump during break-in may cause additional smoke at start up and idle.

CAUTION

DO NOT exceed the one (1) tankful limitation of a 100:1 gas/oil break-in mixture. Continuous use of a gas/oil mixture could cause spark plug fouling and excessive carbon buildup.

During the break-in period, a maximum of 1/2 throttle (with varying throttle positions) is recommended; however, brief full-throttle accelerations and variations in driving speeds contribute to good engine break-in.

Drive Belt Break-In

Drive belts require a break-in period of approximately 25 miles. Drive the snowmobile for 25 miles at 3/4 throttle or less. By revving the engine up and down (but not exceeding 60 mph), the exposed cord on the side of a new belt will be worn down. This will allow the drive belt to gain its optimum flexibility and will extend drive belt life.

■**NOTE:** Before starting the snowmobile in extremely cold temperatures, the drive belt should be removed and warmed up to room temperature. Once the drive belt is at room temperature, install the drive belt (see Drive Belt sub-section in the Drive Train/Track/Brake Systems section of this manual).

CAUTION

Running the engine with the drive belt removed could result in serious engine damage and drive clutch failure.

Genuine Parts

When replacement of parts is necessary, use only genuine Arctic Cat parts. They are precision-made to ensure high quality and correct fit.

Varying Altitude Operation

Operating a snowmobile at varying altitudes requires recalibration of drive system components. Consult the appropriate specification sheet on Cat Tracker Online.

Following are basic altitude theories for clutching, engine, suspension, and track.

CLUTCHING

On a normally-aspirated engine as altitude changes, engine horsepower changes with it. As you go up in altitude, the engine loses horsepower. Because of this, the continuously variable transmission (CVT) system needs to be calibrated to compensate for the horsepower loss.

At altitudes above 5000 ft, the engine loses peak horsepower but will also lose horsepower at engagement speed. For this reason, calibrating the drive system is usually needed in order to attain acceptable performance. Changing drive clutch engagement speed can be done several ways. Some of the methods will affect other characteristics of CVT operation, so you must be careful what you change. Drive clutch springs are the most common way to increase engagement speed; however, by simply changing the cam arms to a lighter weight from the heavier sea level cam arm, you will gain some engagement speed.

The driven clutch will also play a part in CVT tuning for high altitude operation. A steeper helix (torque bracket) angle in the driven clutch will mean a quicker up-shift. A shallower angle will mean a slower up-shift. If the up-shift is too quick, due to a very steep helix, RPM will be pulled down under the peak operating RPM of the engine (where the horsepower is) and performance will suffer. The engine may even bog.

ENGINE

A normally aspirated engine will generate more horsepower at sea level than it does at higher altitudes. The reason is that the higher you go, less oxygen is available for the engine to use during its combustion process. Less oxygen means it needs less fuel to obtain the correct air/fuel ratio to operate properly. This is why the fuel ratio has to be recalibrated. High altitude engines operate as though they have a lower compression ratio. This, along with less oxygen and less fuel, means that the engine generates less horsepower. All of these characteristics will become more evident the higher the altitude.

SUSPENSION

The different riding styles of the individual operator, the varying snow conditions, and the type of terrain are all factors that affect the suspension at high altitude. Trail riding versus powder snow riding versus combination riding will all require different suspension settings.

The normal setting for front ski suspension is as little spring pre-load tension as possible for powder snow riding allowing the skis to float across the snow with the least amount of resistance. Trail riding will require more spring tension to carry the varying load more effectively. Many different settings and spring tensions to consider exist when adjusting for riding style and snow conditions.

The rear suspension has a number of spring settings that produce different riding characteristics.

The front arm spring and shock will also affect the ride and handling when either on a trail or in powder snow. A strong spring setting on this shock will cause the snowmobile to tend to “dig” more when riding in the powder snow rather than climbing up on top of the snow. But, it will work more effectively when riding on a trail. A softer spring setting will allow the front of the rear suspension to collapse much quicker and change the angle of the track to the snow. A more gradual angle will tend to raise the snowmobile up on the snow rather than digging into it.

Many possible variables and adjustments to the rear suspension exist depending on snow conditions, riding style, and type of terrain. These adjustments can be made to individualize the snowmobile to the riding style of the operator.

M/XF High Country

As snow cover and riding conditions change, several different adjustments can be made to change the ride and handling characteristics for operator preference. Located on the front suspension arm are limiter straps. They limit the amount of “fallout” the front arm can have. These straps may be adjusted in or out due to conditions and riding style. The more the straps are brought up, the more steering power the operator has due to the amount of ski pressure.

Another adjustment that can be made on the rear suspension is the front arm shock spring tension. As trail conditions change, the spring pre-load may be used to decrease the chance of the front end “bottoming out.” With a stiffer spring pre-load, the ride of the snowmobile will improve on the trail but will affect the performance in the deep powder snow. In deep powder snow, the stiffer spring pre-load will cause the front-end to “dig” and possibly take longer for it to plane off. Several different-rate springs are available for different riding styles and terrain conditions.

On the standard models, the front shock springs are also individually adjustable for the terrain conditions and driving style of the operator. The spring adjuster has been set at the factory so the correct amount of threads are exposed between the spring adjuster and the shock housing as an initial setting. Additional ski pressure can be obtained by tightening the spring tension; ski pressure can be decreased by relaxing spring tension. Springs with different spring rates are available for operator choice and snow conditions.

A limit exists as to how far you can pre-load the springs before “coil bind” takes effect where the wire on the spring actually runs into itself and causes binding. Equal adjustments should be maintained on both sides of the snowmobile. On the Sno Pro models with float shocks, they are individually adjustable for the terrain conditions and driving style of the operator. The shocks are preset at the factory (see chart) as an initial setting; however, it is possible to “fine tune” the shocks to match the operator’s weight, riding style, and terrain conditions.

Initial Setting Chart		
Model	Front Shock (Ski)	Rear Arm Shock
XF/ZR Sno Pro	60 psi	N/A
XF High Country/M Sno Pro/M LTD	90 psi	145 psi
XF Cross Country	75 psi	145 psi
XF Cross-Tour	N/A	145 psi
XF Cross-Tour OS	75 psi	145 psi
ZR RR	80 psi (Main Chamber) 200 psi (Evol Chamber)	N/A

Checking and adjusting air pressure must be done at riding temperature (outside) and shocks are at full extension with no weight on the shock. Also, it is advisable to check air pressure when the outside temperature varies more than 25°.

NOTE: Care should be taken to have equal pressure in the ski shocks before operating the snowmobile.

Finally, track tension should be looked at to make sure that it is within recommended specifications to affect the efficiency of the snowmobile. On models with the torque sensing link, the track is actually tightening as the suspension moves through its range of motion causing the track to sag in the middle and rub on the top part of the rear suspension arm.

TRACK

Carefully matching the riding requirements to the type of track will ensure the maximum use of all available engine power. Lug height and track durometer are the two main concerns when selecting a track for various riding styles.

Tracks exist with lug heights from 0.750” up to 2.6” to accommodate various snow conditions. Generally, the deeper the snow, the taller the lug. It must be noted that the installation of any deep-lug track may reduce top end speed and promote premature wear strip wear in marginal snow conditions.

Durometer is a measurement of how hard a rubber is. The lugs on most tracks range between 60 and 85 durometer. On the durometer scale, the higher the number, the harder the lugs. For riding in deep powder snow, a softer durometer track works best. The softer rubber allows the track to “give” a little and pack the snow creating lift rather than digging its way straight down. When hill-climbing, the harder lug of an 80 durometer track works the best due to penetrating the hard snow creating more bite.

Some tracks come with a dual durometer rating, such as a track with a 80/60 durometer rating. The lugs on this track are 80% 80 durometer rubber, and the top 20% is made of the softer 60 durometer rubber. This track is designed to be a good all-around track for riding mostly in deep powder snow but can climb the occasional hard snow hill.

Preparation For Storage

Prior to storing the snowmobile, it must be properly serviced to prevent corrosion and component deterioration.

1. Clean the seat cushion with a damp cloth and Arctic Cat Vinyl Protectant.
2. Clean the snowmobile thoroughly by hosing dirt, oil, grass, and other foreign matter from the skid frame, tunnel, hood, and belly pan. Allow the snowmobile to dry thoroughly. DO NOT get water into any part of the engine.
3. Place the rear of the snowmobile up on a shielded safety stand; then start the engine and allow to idle. Spray an Engine Storage Preserver into the intakes until the engine exhaust starts to smoke heavily or until the engine starts to drop in RPM. Turn engine off. Install the intake boots.

CAUTION

Do not run the engine without the belt guard in place and secured.

4. Plug the exhaust system outlet with a clean cloth.
5. With the ignition switch in the OFF position:
 - A. Disconnect the high tension leads from the spark plugs; then remove the plugs, connect them to the leads, and ground them on the cylinder heads.

CAUTION

Never crank the engine over without grounding the spark plugs. Damage to coils and/or ECM may result.

- B. Pour 29.5 ml (1 fl oz) of SAE #30 petroleum-based oil into each spark plug hole and pull the recoil starter handle slowly about 10 times.
- C. Install the spark plugs and connect the high tension leads.

6. Fill the gas tank to its rated capacity; then add Arctic Cat Fuel Stabilizer to the gas tank following directions on the container for the stabilizer/gasoline ratio. Tighten the gas tank cap securely.
7. With the snowmobile level, check the lubricant level in the chain case. If low, add chain lube through the fill plug hole.
8. Remove the drive belt from the drive clutch/driven clutch. Lay the belt on a flat surface or slide it into a cardboard sleeve to prevent warping or distortion during storage; then clean and inspect the drive clutch and driven clutch.
9. Apply light oil to the upper steering post bushings and to the shafts of the shock absorbers; then lubricate the rear suspension with an all-temperature grease.
10. Tighten all nuts, bolts, and cap screws making sure all calibrated nuts, bolts, and cap screws are tightened to specifications. Make sure all rivets holding the components together are tight. Replace all loose rivets.
11. Clean and polish the hood, console, and chassis with Cat Cleaner. DO NOT USE SOLVENTS. THE PROPPELLANT WILL DAMAGE THE FINISH.
12. On electric start models, disconnect the battery cables making sure to disconnect the negative cable first; then clean the battery posts and cables.

CAUTION

Sealed batteries require charging if left for extended non-start periods. Arctic Cat recommends trickle charging once a month. Follow the manufacturer's instructions and cautions.

13. If possible, store the snowmobile indoors. Raise the track off the floor by blocking up the back end making sure the snowmobile is secure. Loosen the track adjusting bolts to reduce track tension. Cover the snowmobile with a machine cover or a heavy, ventilated tarpaulin to protect it from dirt and dust.
14. If the snowmobile must be stored outdoors, position the snowmobile out of direct sunlight; then block the entire snowmobile off the ground making sure the snowmobile is secure. Loosen the track adjusting bolts to reduce track tension. Cover with a machine cover or a heavy, ventilated tarpaulin to protect it from dirt, dust, and rain.

CAUTION

Avoid storing in direct sunlight and using a plastic cover as moisture may collect on the snowmobile causing corrosion.

Preparation After Storage

Taking the snowmobile out of storage and correctly preparing it for another season will assure many miles and hours of trouble-free snowmobiling. Arctic Cat recommends the following procedure:

1. Clean the snowmobile thoroughly. Polish the exterior of the snowmobile.
2. Clean the engine. Remove the cloth from the exhaust system. Check exhaust system and air silencer for obstructions.
3. Inspect all control wires and cables for signs of wear or fraying. Replace if necessary. Use cable ties or tape to route wires and cables away from hot or rotating parts.
4. Inspect the drive belt for cracks and tears. Check belt specifications. Replace if damaged or worn. Install the drive belt.

NOTE: If the old belt is worn but in reasonable condition, retain it with the snowmobile as a spare in case of emergency.

5. Adjust the throttle cable. Inspect all fuel hoses and oil hoses for deterioration or cracks; replace if necessary. Make sure all connections are tight.
6. Fill the oil-injection reservoir with the recommended 2-cycle oil; then inspect each spark plug. Replace, gap, or clean as necessary.

NOTE: After prolonged storage on the 8000, Arctic Cat recommends one tankful of 100:1 gas/oil mixture be used in conjunction with the oil-injection system to ensure proper lubrication.

7. Tighten all nuts, bolts, and cap screws making sure all calibrated nuts, bolts, and cap screws are tightened to specifications.
8. If not done during preparation for storage, lubricate the rear suspension with an all-temperature grease.
9. Check the coolant level and all coolant hoses and connections for deterioration or cracks. Add properly mixed coolant as necessary.
10. On electric start models, charge the battery; then connect the battery cables making sure to connect the positive cable first. Test the electric start system.
11. Inspect the entire brake system, all controls, headlight, taillight, brake light, ski wear bars, and headlight aim; adjust or replace as necessary.
12. Adjust the track to the proper tension and alignment.

After Break-In Checkup/ Checklist

Certain areas require adjustment after the break-in period in order to obtain peak performance. These areas are the following.

DRIVE BELT DEFLECTION — Drive belt deflection is very important to the snowmobile. Even if it is checked and is correct when the snowmobile is set up, it does change (more so during the break-in period). This is because the rubber engine mounts and the rubber snubber on the torque link will all take a “set” during the first 100 miles allowing the distance between the drive clutch and driven clutch to shorten. When this happens, the snowmobile will appear to have too long of a drive belt. To add to this, the drive belt wears and stretches. This sometimes leads to a reduction in low-end performance, and if not corrected, can cause premature drive belt wear.

After the break-in period, drive belt deflection should be checked according to the instructions given in the Drive Train/Track/Brake Systems section of this manual.

DRIVE CLUTCH/DRIVEN CLUTCH

ALIGNMENT (OFFSET) — The alignment between the drive clutch and driven clutch are set at the factory. Normally, no adjustment is necessary; however, if premature drive belt wear or poor performance is experienced, the drive clutch/driven clutch alignment must be checked. See “Checking Offset” in the driven train section in this manual.

TRACK TENSION AND ALIGNMENT — A certain amount of stretch occurs on all tracks during the first 500 miles. The track must be inspected/adjusted after the first 50 to 100 miles to the specifications given in the Track Specifications sub-section of this section and periodically thereafter. If these adjustments aren’t performed, the track may “derail” which leads to track and slide rail damage.

Along with these major areas, other areas should be checked and adjusted.

Below is a list of items to check after the break-in period. The recommended mileage for this inspection is between 100 and 300 miles.

- Check drive belt deflection - drive clutch/driven clutch alignment
- Adjust track tension and alignment
- Check throttle cable tension
- Check oil-injection pump adjustment (4000/8000)
- Check engine idle
- Check coolant level
- Check chain case lubricant level
- Check lights (high/low beam, brakelight)
- Check safety switch operation
- Check engine compartment for any rubbing components
- Check steering hardware for tightness
- Check skid frame and A-arm mounting hardware for tightness
- Check brake lever travel and adjustment
- Grease all lubrication points

Engine Specifications

4000

ITEM	
Engine Model Number	AX50L9
Displacement	499 cc
Bore x Stroke	71 x 63
Compression Ratio	6.38:1
Cooling System	Liquid
Ignition Timing (Engine Warm)	13° @ 2000 RPM 0.040"
Spark Plug (NGK)	BR9EYA
Spark Plug Gap	0.028-0.031"
Piston Skirt/Cylinder Clearance	0.0031-0.0041"
Piston Ring End Gap	0.008-0.016"
Cylinder Trueness Limit	0.004"
Piston Pin Diameter	0.8659-0.8661"
Piston Pin Bore Diameter	0.8661-0.8665"
Connecting Rod Small End Bore	1.0631-1.0634"
Connecting Rod Radial Play	0.0001-0.0008"
Crankshaft Runout (t.i.r.)	0.002"
Crankshaft End Play	0.002-0.004"
Reed Stopper Height	0.315"

6000

ITEM	
Engine Number	0962-011
Displacement	599 cc
Bore x Stroke	73.8 x 70 mm
Compression Ratio	6.62:1
Cooling System	Liquid
Ignition Timing (Engine Warm)	16.5° @ 2000 RPM 0.072"
Spark Plug (NGK)	BPR9ES
Spark Plug Gap	0.028-0.031"
Piston Skirt/Cylinder Clearance	0.0041-0.0053"
Piston Ring End Gap	0.012-0.0196"
Cylinder Trueness Limit	0.004"
Piston Pin Diameter	0.8659-0.8661"
Piston Pin Bore Diameter	0.8661-0.8665"
Connecting Rod Small End Bore	1.0631-1.0634"
Connecting Rod Radial Play	0.0001-0.0008"
Crankshaft Runout (t.i.r.)	0.002"
Crankshaft End Play	0.002-0.004"
Reed Stopper Height	0.512"

8000

ITEM	
Engine Model Number	AB80L4
Displacement	794 cc
Bore x Stroke	85 x 70
Compression Ratio	6.62:1
Cooling System	Liquid
Ignition Timing (Engine Warm)	16.5° @ 2000 RPM 0.072"
Spark Plug (NGK)	BR9EYA
Spark Plug Gap	0.028-0.031"
Piston Skirt/Cylinder Clearance	0.0041-0.0053"
Piston Ring End Gap	0.012-0.0196"
Cylinder Trueness Limit	0.004"
Piston Pin Diameter	0.8659-0.8661"

ITEM	
Piston Pin Bore Diameter	0.8661-0.8665"
Connecting Rod Small End Bore	1.0631-1.0634"
Connecting Rod Radial Play	0.0001-0.0008"
Crankshaft Runout (t.i.r.)	0.002"
Crankshaft End Play	0.002-0.004"
Reed Stopper Height	0.512"

Crankshaft Runout/ Repair Specifications

To use the specifications, first refer to the drawing; then find the letter indicating the specification and refer to the chart below the illustration.

■ **NOTE:** The proper location for checking crankshaft runout is the very edge of the straight portion of the shaft where the oil seal makes contact. From the illustration, note that three check points are called out: at either end, out on the taper as shown, and also on the center bearing race. The crankshaft is still supported on the outer bearings using V blocks.

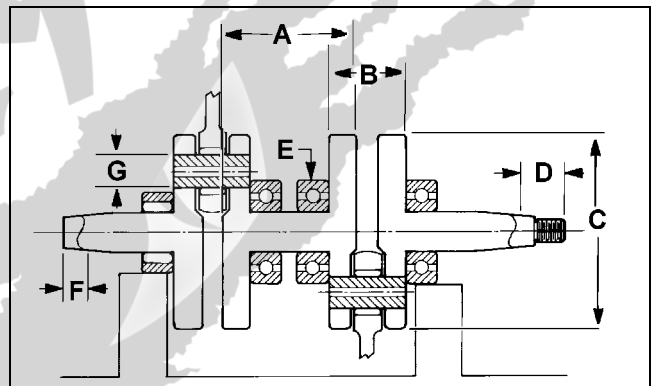

728-144A

Model	A ± 0.006	B ± 0.006	C ± 0.015	G	Runout D and F Point ± 0.002	
4000	4.515"	2.618"	4.465"	1.062"	D 0.196"	F 0.196"
8000	4.751"	2.519"	4.645"	1.181"	D 0.196"	F 0.196"

■ **NOTE:** Measure in from the shaft end the specified amount when checking runout at points D and F. When checking runout in the center, place indicator on center of bearing as shown at point E. Maximum runout at any of the three measuring points is ± 0.002".

6000

NOTE: The crankshaft must be supported on the inner bearings using V blocks.

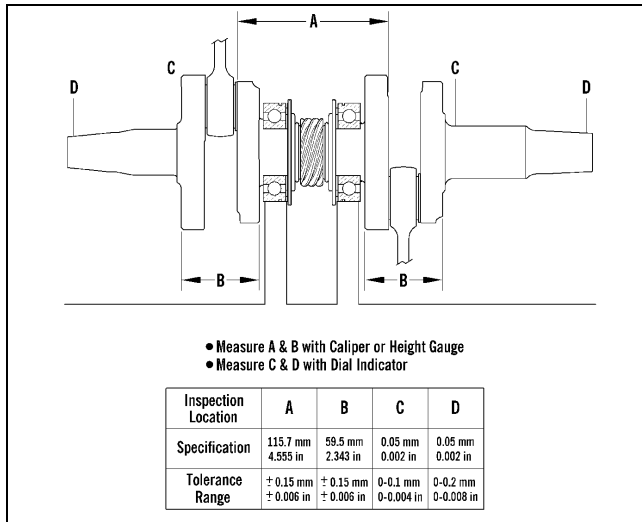

0747-810

Arctic Power Valve (APV) System Specifications

VALVE POSITION	CYCLE RPM
Mid-Open	67-7500 (Low/High Alt)
Full-Open	77-8500 (Low/High Alt)

APV CABLE LENGTH	
6000/8000	36.5 mm ± 1 mm

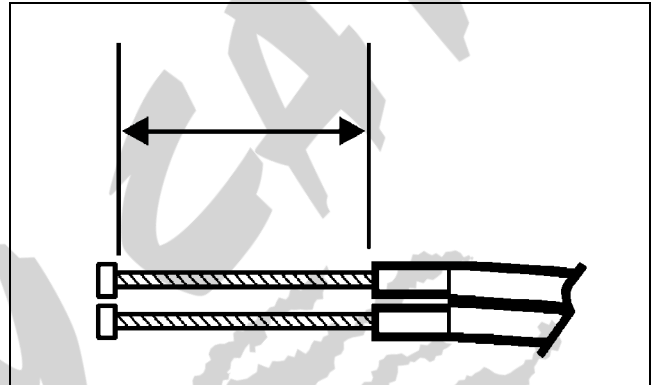

0735-516

Electrical Specifications

Component	Test Value	+ Test Connections -	
Spark Plug Cap	4000-6000 ohms	cap end	cap end
Oil Level Sensor	Less than 1 ohm (float end down)	terminal	terminal
Ignition Switch	Less than 1 ohm (key in OFF position)	terminal	terminal
4000 (Normally Open Ignition)			
Ignition Coil (Primary)	0.24-0.36 ohm	orange/black	orange/red
Ignition Coil (Secondary)	6800-10,200 ohms	high tension wire	ground
Charge Coil (1)	8.8-13.2 ohms	black/red	green/red
Charge Coil (2)	8.8-13.2 ohms	brown/white	green/red
Lighting Coil	0.08-0.12 ohm	yellow	yellow
Ignition Timing Sensor	80.8-121 ohms	green/white	brown/green
Fuel Injector	10-14 ohms	terminal	terminal
Injection Coil	15.2-22.8 ohms	blue/white	blue/white
Fuel Pump Coil	1.52-2.28 ohms	orange	orange
Chassis Control Unit*	10-15 DC Volts	red/blue (low power) red/black (high power)	black (low power) black (high power)
6000 (Normally Open Ignition)			
Ignition Coil (Primary)	0.24-0.36 ohm	black/white	white/blue
Ignition Coil (Secondary)	5040-7560 ohms	high tension wire	ground
Charge Coil (1)	8.8-13.2 ohms	black/red	green/red
Charge Coil (2)	8.8-13.2 ohms	brown/white	green/red
Lighting Coil	0.08-0.12 ohm	yellow	yellow
Ignition Timing Sensor (1)	148-222 ohms	green/white	brown/green
Ignition Timing Sensor (2)	148-222 ohms	green/white	brown/green
Fuel Injector	11.4-12.6 ohms	terminal	terminal
Injection Coil	15.2-22.8 ohms	blue/white	blue/white
Fuel Pump Coil	1.52-2.28 ohms	orange	orange
Servomotor	12 DC Volts	red/black (counterclockwise) black/red (clockwise)	black/red (counterclockwise) red/black (clockwise)
Voltage Regulator/Rectifier*	9-14.5 DC Volts	red/blue	black
8000 (Normally Open Ignition)			
Ignition Coil (Primary)	0.24-0.36 ohm	black/white	white/blue
Ignition Coil (Secondary)	5040-7560 ohms	high tension wire	ground
Charge Coil (1)	8.8-13.2 ohms	black/red	green/red
Charge Coil (2)	8.8-13.2 ohms	brown/white	green/red
Lighting Coil	0.08-0.12 ohm	yellow	yellow
Ignition Timing Sensor (1)	148-222 ohms	green/white	brown/green
Ignition Timing Sensor (2)	148-222 ohms	green/white	brown/green
Fuel Injector	10-14 ohms	terminal	terminal
Injection Coil	15.2-22.8 ohms	blue/white	blue/white
Fuel Pump Coil	1.52-2.28 ohms	orange	orange
Servomotor	12 DC Volts	red/black (counterclockwise) black/red (clockwise)	black/red (counterclockwise) red/black (clockwise)
Voltage Regulator/Rectifier*	10-15 DC Volts 11-14 AC Volts	red/blue yellow	brown brown

* Harness plugged in

The main harness connectors must be unplugged (except on the primary coil and regulator/rectifier tests), the spark plugs removed and grounded, and by pulling the recoil starter rope briskly.

■ **NOTE:** Lighting coil output is unregulated voltage.

⚠ WARNING

Most voltages generated by the ignition system are sufficient to interrupt pacemakers! All technicians, especially those using pacemakers, must avoid contact with all electrical connections when pulling the recoil starter rope or after the engine has been started.

Drive System Specifications

Model	Altitude	Drive Clutch Spring	Cam Arm	Driven Clutch Spring	Torque Bracket	Drive Belt	Engagement RPM	Peak RPM	Top Gear	Bottom Gear	Chain Pitch
ZR 4000 LXR	0-5000	Yellow/White	63g	Black/Blue	42°/40°	0627-083	36-4000	81-8200	21T	49T	90
ZR 4000 RR	0-5000	Yellow/White	63g	Black/White	44°/42°	0627-083	36-4000	81-8200	21T	49T	90
XF 6000 Cross Tour	0-5000	Green	64g	Black/Blue	42°/40°	0627-083	42-4600	81-8200	21T	49T	90
ZR 6000/XF 6000 CC	0-5000	Green	64g	Black/Blue	42°/40°	0627-083	42-4600	81-8200	22T	48T	90
ZR 8000	0-5000	Green	73.5g	Black/Blue	44°/40°	0627-083	36-4000	81-8200	21T	41T	86
M 6000	6-9000	Yellow/White	60g	Brown	36°	0627-083	42-4600	81-8200	19T	50T	90
M 8000	6-9000	Yellow/White	68g	Black/Blue	36°	0627-084	42-4600	81-8200	19T	50T	90
XF 8000 LXR/Cross Tour/ Cross Country/Sno Pro	0-3000	Green	73.5g	Black/Blue	42°/40°	0627-083	36-4000	81-8200	22T	48T	90
XF 8000 High Country	6-9000	Yellow/White	68g	Black/Blue	36°	0627-084	42-4600	81-8200	19T	50T	90
XF 6000 High Country	6-9000	Yellow/White	60g	Brown	36°	0627-083	42-4600	81-8200	19T	50T	90

Drive Clutch/Driven Clutch-Related Specifications

ALIGNMENT BAR			
OFFSET P/N	CENTER-TO-CENTER	OFFSET	FLOAT
0644-428	12.10"	1.485"	None

Drive System Components

A list of Drive System components that are available through the Arctic Cat Service Parts Department can be found in the Quick Reference Guide. This information will be useful when doing any fine-tuning on the drive system.

Chain Case Performance Calibrations

Drive Sprocket	Gear Ratio		Ratio	Chain	Engine RPM														
					6200	6400	6600	6800	7000	7200	7400	7600	7800	8000	8200	8400	8600	8800	9000
					Vehicle Speed (mph)														
7 Tooth (3.0" pitch)	19	50	0.380	90	52	54	56	58	59	61	63	64	66	68	69	71	73	74	76
	21	49	0.429	90	59	61	63	65	67	69	71	73	74	76	78	80	82	84	86
	20	46	0.435	88	60	62	64	66	68	70	72	74	75	77	79	81	83	85	87
	23	51	0.451	92	62	64	66	68	70	72	74	76	78	80	82	84	86	88	90
	22	48	0.458	90	63	65	67	69	71	73	76	78	80	82	84	86	88	90	92
	24	50	0.480	92	66	68	71	73	75	77	79	81	83	85	88	90	92	94	96
	21	41	0.512	86	71	73	75	78	80	82	84	87	89	91	93	96	98	100	103
	21	38	0.553	84	76	79	81	84	86	89	91	93	96	98	101	103	106	108	111
	20	35	0.571	82	79	81	84	87	89	92	94	97	99	102	104	107	109	112	114
	23	40	0.575	86	79	82	84	87	90	92	95	97	100	102	105	108	110	113	115
	22	37	0.595	84	82	85	87	90	93	95	98	101	103	106	109	111	114	116	119
	24	39	0.615	86	85	88	90	93	96	99	101	104	107	110	112	115	118	121	123
	23	36	0.639	84	88	91	94	97	100	102	105	108	111	114	117	119	122	125	128
	24	35	0.686	84	95	98	101	104	107	110	113	116	119	122	125	128	131	134	137
8 Tooth (2.86" pitch)	19	50	0.380	90	57	59	61	63	65	66	68	70	72	74	76	77	79	81	83
	21	49	0.429	90	64	67	69	71	73	75	77	79	81	83	85	87	89	91	94
	20	46	0.435	88	65	67	70	72	74	76	78	80	82	84	86	89	91	93	95
	23	51	0.451	92	68	70	72	74	77	79	81	83	85	88	90	92	94	96	98
	22	48	0.458	90	69	71	73	76	78	80	82	84	87	89	91	93	96	98	100
	24	50	0.480	92	72	75	77	79	81	84	86	88	91	93	95	98	100	102	105
	21	41	0.512	86	77	80	82	84	87	89	92	94	97	99	102	104	107	109	112
	21	38	0.553	84	83	86	88	91	94	97	99	102	105	107	110	113	115	118	121
	20	35	0.571	82	86	89	91	94	97	100	103	105	108	111	114	116	119	122	125
	23	40	0.575	86	86	89	92	95	98	100	103	106	109	112	114	117	120	123	126
	22	37	0.595	84	89	92	95	98	101	104	107	110	112	115	118	121	124	127	130
	24	39	0.615	86	93	96	99	101	104	107	110	113	116	119	122	125	128	131	134
	23	36	0.639	84	96	99	102	105	108	112	115	118	121	124	127	130	133	136	139
	24	35	0.686	84	103	106	110	113	116	120	123	126	130	133	136	140	143	146	150
8 Tooth (3.0" pitch)	19	50	0.380	90	60	62	64	66	68	70	72	73	75	77	79	81	83	85	87
	21	49	0.429	90	68	70	72	74	76	79	81	83	85	87	89	92	94	96	98
	20	46	0.435	88	69	71	73	75	77	80	82	84	86	88	91	93	95	97	100
	23	51	0.451	92	71	73	76	78	80	83	85	87	89	92	94	96	99	101	103
	22	48	0.458	90	72	75	77	79	82	84	86	89	91	93	96	98	100	103	105
	24	50	0.480	92	76	78	81	83	85	88	90	93	95	98	100	103	105	107	110
	21	41	0.512	86	81	83	86	89	91	94	96	99	102	104	107	109	112	115	117
	21	38	0.553	84	87	90	93	96	98	101	104	107	110	112	115	118	121	124	127
	20	35	0.571	82	90	93	96	99	102	105	108	110	113	116	119	122	125	128	131
	23	40	0.575	86	91	94	97	99	102	105	108	111	114	117	120	123	126	129	132
	22	37	0.595	84	94	97	100	103	106	109	112	115	118	121	124	127	130	133	136
	24	39	0.615	86	97	100	103	106	110	113	116	119	122	125	128	132	135	138	141
	23	36	0.639	84	101	104	107	111	114	117	120	124	127	130	133	137	140	143	146
	24	35	0.686	84	108	112	115	119	122	126	129	133	136	140	143	147	150	154	157

Drive Sprocket	Gear Ratio		Ratio	Chain	Engine RPM														
	Top	Btm			6200	6400	6600	6800	7000	7200	7400	7600	7800	8000	8200	8400	8600	8800	9000
					Vehicle Speed (mph)														
9 Tooth (2.52" pitch)	19	50	0.380	90	57	58	60	62	64	66	68	69	71	73	75	77	79	80	82
	21	49	0.429	90	64	66	68	70	72	74	76	78	80	82	84	87	89	91	93
	20	46	0.435	88	65	67	69	71	73	75	77	79	82	84	86	88	90	92	94
	23	51	0.451	92	67	69	72	74	76	78	80	82	85	87	89	91	93	95	98
	22	48	0.458	90	68	71	73	75	77	79	82	84	86	88	90	93	95	97	99
	24	50	0.480	92	72	74	76	78	81	83	85	88	90	92	95	97	99	102	104
	21	41	0.512	86	76	79	81	84	86	89	91	94	96	99	101	103	106	108	111
	21	38	0.553	84	82	85	88	90	93	96	98	101	104	106	109	112	114	117	120
	20	35	0.571	82	85	88	91	93	96	99	102	104	107	110	113	115	118	121	124
	23	40	0.575	86	86	88	91	94	97	100	102	105	108	111	113	116	119	122	124
	22	37	0.595	84	89	91	94	97	100	103	106	109	112	114	117	120	123	126	129
	24	39	0.615	86	92	95	98	101	104	107	109	112	115	118	121	124	127	130	133
	23	36	0.639	84	95	98	101	104	108	111	114	117	120	123	126	129	132	135	138
	24	35	0.686	84	102	106	109	112	115	119	122	125	129	132	135	138	142	145	148
9 Tooth (2.86" pitch)	19	50	0.380	90	64	66	68	71	73	75	77	79	81	83	85	87	89	91	93
	21	49	0.429	90	73	75	77	80	82	84	87	89	91	94	96	98	101	103	105
	20	46	0.435	88	74	76	78	81	83	85	88	90	93	95	97	100	102	104	107
	23	51	0.451	92	76	79	81	84	86	89	91	94	96	98	101	103	106	108	111
	22	48	0.458	90	78	80	83	85	88	90	93	95	98	100	103	105	108	110	113
	24	50	0.480	92	81	84	86	89	92	94	97	100	102	105	107	110	113	115	118
	21	41	0.512	86	87	89	92	95	98	101	103	106	109	112	115	117	120	123	126
	21	38	0.553	84	93	97	100	103	106	109	112	115	118	121	124	127	130	133	136
	20	35	0.571	82	97	100	103	106	109	112	115	118	122	125	128	131	134	137	140
	23	40	0.575	86	97	100	104	107	110	113	116	119	122	126	129	132	135	138	141
	22	37	0.595	84	101	104	107	110	114	117	120	123	127	130	133	136	140	143	146
	24	39	0.615	86	104	107	111	114	118	121	124	128	131	134	138	141	144	148	151
	23	36	0.639	84	108	112	115	119	122	126	129	132	136	139	143	146	150	153	157
	24	35	0.686	84	116	120	123	127	131	135	138	142	146	150	153	157	161	165	168
9 Tooth (3.0" pitch)	19	50	0.380	88	67	70	72	74	76	78	80	83	85	87	89	91	94	96	98
	21	49	0.429	90	76	79	81	83	86	88	91	93	96	98	101	103	105	108	110
	20	46	0.435	88	77	80	82	85	87	90	92	95	97	100	102	105	107	110	112
	23	51	0.451	92	80	83	85	88	90	93	96	98	101	103	106	108	111	114	116
	22	48	0.458	90	81	84	87	89	92	94	97	100	102	105	108	110	113	115	118
	24	50	0.480	92	85	88	91	93	96	99	102	104	107	110	113	115	118	121	124
	21	41	0.512	86	91	94	97	100	103	106	108	111	114	117	120	123	126	129	132
	21	38	0.553	84	98	101	104	108	111	114	117	120	123	127	130	133	136	139	142
	20	35	0.571	82	101	105	108	111	114	118	121	124	128	131	134	137	141	144	147
	23	40	0.575	86	102	105	109	112	115	118	122	125	128	132	135	138	142	145	148
	22	37	0.595	84	106	109	112	116	119	123	126	129	133	136	140	143	146	150	153
	24	39	0.615	86	109	113	116	120	123	127	130	134	137	141	144	148	151	155	159
	23	36	0.639	84	113	117	121	124	128	132	135	139	143	146	150	154	157	161	165
	24	35	0.686	84	122	126	130	133	137	141	145	149	153	157	161	165	169	173	177
10 Tooth (2.52" pitch)	19	50	0.380	90	63	65	67	69	71	73	75	77	79	81	83	85	87	89	91
	21	49	0.429	90	71	73	76	78	80	82	85	87	89	92	94	96	98	101	103
	20	46	0.435	88	72	74	77	79	81	84	86	88	91	93	95	98	100	102	105
	23	51	0.451	92	75	77	80	82	84	87	89	92	94	96	99	101	104	106	108
	22	48	0.458	90	76	78	81	83	86	88	91	93	96	98	100	103	105	108	110
	24	50	0.480	92	80	82	85	87	90	92	95	97	100	103	105	108	110	113	115
	21	41	0.512	86	85	88	90	93	96	99	101	104	107	109	112	115	118	120	123
	21	38	0.553	84	92	94	97	100	103	106	109	112	115	118	121	124	127	130	133
	20	35	0.571	82	95	98	101	104	107	110	113	116	119	122	125	128	131	134	137
	23	40	0.575	86	95	98	101	104	108	111	114	117	120	123	126	129	132	135	138
	22	37	0.595	84	98	102	105	108	111	114	118	121	124	127	130	133	137	140	143
	24	39	0.615	86	102	105	108	112	115	118	122	125	128	132	135	138	141	145	148
	23	36	0.639	84	106	109	113	116	119	123	126	130	133	137	140	143	147	150	154
	24	35	0.686	84	114	117	121	125	128	132	136	139	143	147	150	154	158	161	165

Track Specifications

Model	Length	Lug Height	Track Tension	
			Setup	After Break-in
ZR LXR	129"	1"	2-2.25"	2-2.25"
ZR Sno Pro/El Tigre	129"	1.25"	2-2.25"	2-2.25"
M Standard	153"/162"	2.25"	2-2.25"	2-2.25"
M Sno Pro/HCR/LTD	153"/162"	2.6"	2-2.25"	2-2.25"
XF Standard	137"	1.25"	2-2.25"	2-2.25"
XF Cross Country	141"	1.6"	2-2.25"	2-2.25"
XF Cross Tour	141"	1.352"	2-2.25"	2-2.25"
XF HC	141"	2.25"	2-2.25"	2-2.25"
XF Sno Pro	141"	1.5"	2-2.25"	2-2.25"

NOTE: The track tension on 129" and 137" models should be @ 20 lb. The track tension on 141", 153", and 162" models should be at 12-15 lb.

Suspension Specifications

SPRINGS

SKI SHOCK					
Model	Wire Diameter	Free Length	Rate	Coils	Tab
ZR/XF	0.312"	13.00"	95 lb/in.	10	NO
FRONT ARM					
Model	Wire Diameter	Free Length	Rate	Coils	Tab
ZR/XF	0.312"	8.25"	90/250 lb/in.	9.8	NO
M 8000	0.295"	7.75"	110 lb/in.	7.0	NO
REAR ARM					
Model	Wire Diameter	Free Length	Rate	Coils	Tab
M Std/XF	0.375"	13.00"	175 lb/in.	10.5	NO
REAR ARM (See Illustration Below)					
Model	Wire Diameter (A)	Angle (B)	Coil Width (C)	Coils	Length (D)
ZR	.405"	90°	3.65"	6.75	18.50"

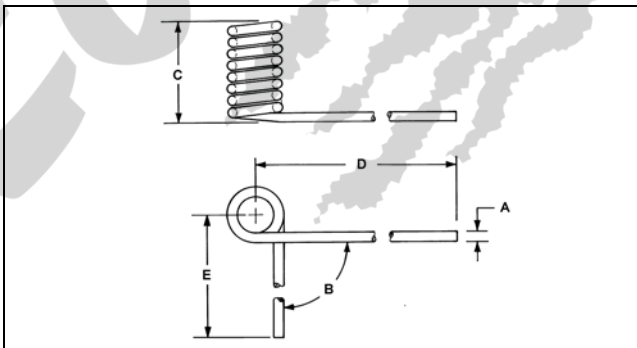

0730-218

IFP SHOCK ABSORBERS

Below is a list of IFP shock absorbers used on the front and rear suspensions of Arctic Cat snowmobiles. If replacing a shock absorber, always select a shock absorber with the same length, both collapsed and extended.

SKI				
Model	Collapsed Length	Extended Length	Stroke	Piston Depth
ZR/XF	12.59"	18.38"	5.79"	7.00"
M	11.32"	17.18"	6.09"	7.00"
FRONT ARM				
Model	Collapsed Length	Extended Length	Stroke	Piston Depth
ZR	8.16"	11.76"	3.71"	5.14"
XF	8.56"	12.50"	3.93"	3.97"
M Standard	8.10"	11.25"	3.15"	5.01"
REAR ARM				
Model	Collapsed Length	Extended Length	Stroke	Piston Depth
ZR LXR	10.08"	14.37"	4.48"	0.90"
XF LXR	10.32"	15.12"	4.79"	0.89"
M Standard	11.10"	16.00"	5.10"	5.01"

Torque Conversions

ft-lb	N-m	ft-lb	N-m	ft-lb	N-m	ft-lb	N-m
1	1.4	26	35.4	51	69.4	76	103.4
2	2.7	27	36.7	52	70.7	77	104.7
3	4.1	28	38.1	53	72.1	78	106.1
4	5.4	29	39.4	54	73.4	79	107.4
5	6.8	30	40.8	55	74.8	80	108.8
6	8.2	31	42.2	56	76.2	81	110.2
7	9.5	32	43.5	57	77.5	82	111.5
8	10.9	33	44.9	58	78.9	83	112.9
9	12.2	34	46.2	59	80.2	84	114.2
10	13.6	35	47.6	60	81.6	85	115.6
11	15	36	49	61	83	86	117
12	16.3	37	50.3	62	84.3	87	118.3
13	17.7	38	51.7	63	85.7	88	119.7
14	19	39	53	64	87	89	121
15	20.4	40	54.4	65	88.4	90	122.4
16	21.8	41	55.8	66	89.8	91	123.8
17	23.1	42	57.1	67	91.1	92	125.1
18	24.5	43	58.5	68	92.5	93	126.5
19	25.8	44	59.8	69	93.8	94	127.8
20	27.2	45	61.2	70	95.2	95	129.2
21	28.6	46	62.6	71	96.6	96	130.6
22	29.9	47	63.9	72	97.9	97	131.9
23	31.3	48	65.3	73	99.3	98	133.3
24	32.6	49	66.6	74	100.6	99	134.6
25	34	50	68	75	102	100	136

Torque Specifications

■NOTE: Torque specifications have the following tolerances:

Torque (ft-lb)	Tolerance
0-15	±20%
16-39	±15%
40+	±10%

DRIVE SYSTEM		
Item	Secured to	Torque ft-lb
Drive Clutch***	Engine	51
Drive Clutch Cover	Movable Sheave	120 in.-lb
Ring Gear*	Drive Clutch	22
Cam Arm Pin Lock Nut	Cam Arm Pin	11
Cam Arm Set Screw	Cam Arm	19 in.-lb
Driven Clutch**	Driven Shaft	20
Movable Sheave*	Torque Bracket	27
Chain Case (Cap Screw)	Chassis	96 in.-lb
Chain Case (Torx-Head Screw)	Chassis	12
Chain Case Cover	Chain Case	12
Brake Caliper	Chassis	25
Outside Caliper Housing	Inside Caliper Housing	25
Brakeline	Caliper	25
Brakeline	Master Cylinder	25
Brake Caliper	Shield Cover	96 in.-lb

STEERING/FRONT SUSPENSION/CHASSIS		
Item	Secured to	Torque ft-lb
Ski	Spindle	35
Ski	Wearbar	8
Ski	Ski Handle	54 in.-lb
Handlebar Adjuster Block (Standard)	Post	15
Handlebar Adjuster (Sno Pro)	Post	15
Steering Support	Mounting Block	8
Steering Tie Rod Link	Steering Post	35
Steering Tie Rod Link	Steering Arm	20
Steering Post Cap	Riser Block	15
Steering Post	Chassis	55
Steering Tie Rod	Steering Arm	20
Tie Rod	Spindle Arm	32
Steering Support	Spar	20
Steering Support	Upper Console	30 in.-lb
Steering Arm	Chassis	8
A-Arm (Upper) (M)	Chassis	9
A-Arm (Upper)	Chassis	23
A-Arm (Lower)	Chassis (Front)	65
A-Arm (Lower)	Chassis (Rear)	45
A-Arm	Spindle	45
Shock Absorber (ZR, XF)	Spindle	32
Shock Absorber (ZR, XF)	Chassis	32
Shock Absorber (M)	Spindle	24
Shock Absorber (M)	Chassis	24
Sway Bar Link	A-Arm/Sway Bar Link	23
Sway Bar Mounting Bracket	Chassis	9

* w/Green Loctite #609

** w/Blue Loctite #243

*** w/Oil

REAR SUSPENSION		
Item	Secured to	Torque ft-lb
M/XF 141"		
Wear Strip	Rail	50 in.-lb
End Cap (XF)	Rail	80 in.-lb
End Cap/Rail Cap Wheel (M)	Rail	20
Mounting Block	Rail	12
Rear Wheel Axle	Rail	34
Rear Arm	Rail	20
Idler Arm	Rear Arm	20
Front Shock	Rail	50
Rear Shock	Front Arm/Idler Arm	24
Rail Support	Rail	20
Front Shock	Front Arm	24
Limiter Strap	Rail Support	72 in.-lb
Rail	Rail Brace	12
Rear Tri Hub Wheel	Rear Tri Hub Wheel	50 in.-lb
Rear Shock Link	Front Arm/Idler Arm	24
Front Arm	Rail	52
Skid Frame	Tunnel	45
ZR/XF 137"		
Wear Strip	Rail	50 in.-lb
End Cap	Rail	80 in.-lb
Mounting Block	Rail	12
Rear Arm	Rail	45
Rear Arm	Idler Arm	55
Spring Slide	Rail	20
Front Arm	Rail	52
Coupler Block Axle	Rail	40
Limiter Strap	Rail Support	72 in.-lb
Rear Tri Hub Wheel	Rear Tri Hub Wheel	50 in.-lb
Rear Wheel Axle	Rail	34
Skid Frame	Tunnel	55**
Front Shock	Rail	50
Rail Support	Rail	20
Limiter Strap	Front Arm	72 in.-lb

Steering and Body

This section has been organized into sub-sections for servicing steering and body components; however, some components may vary from model to model. The technician should use discretion and sound judgment when removing and installing components.

■NOTE: Whenever a part is worn excessively, cracked, or damaged in any way, replacement is necessary.

SPECIAL TOOLS

A number of special tools must be available to the technician when servicing the steering and body systems.

Description	p/n
Shock Spring Removal Tool	0644-057
Handlebar Stand	5639-152
Steering Post Stand	5639-946

■NOTE: Special tools are available from the Arctic Cat Service Parts Department.

Steering Post (ZR/XF)

REMOVING

1. Remove the hairpin clip from the pin located at the front of the access panel. Move the panel up and off the pin; then swing the panel all the way out and unhinge the panel from the lower console.
2. Remove all six torx-head screws securing the hood.

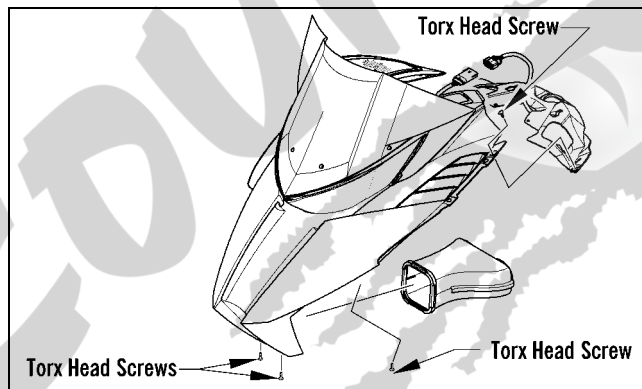

0746-793

3. Locate the hood harness connector (located under the center vent and between the intake vents) and unplug the connector; then move the hood slightly forward and remove the hood.
4. Disconnect the exhaust temperature sensor from the main harness; then remove all springs securing the expansion chamber. Remove the expansion chamber.
5. Remove the push rivets securing the right-side steering boot to the chassis. This allows access to the two nuts securing the bottom of the steering post.

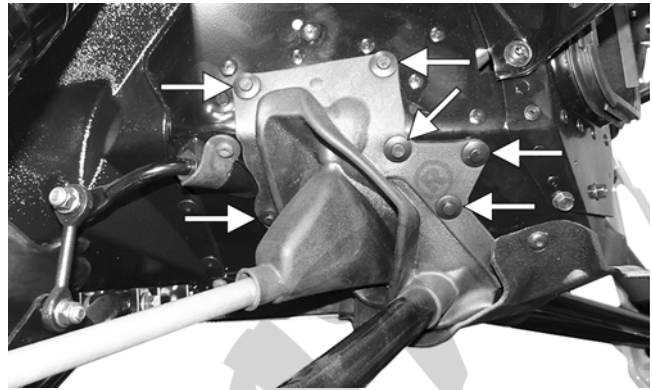

XM134A

6. Remove the nut (A) securing the bottom of the existing steering post to the steering stop bracket; then remove the nut (B) securing the steering tie rod assembly to the steering post. Discard both nuts.

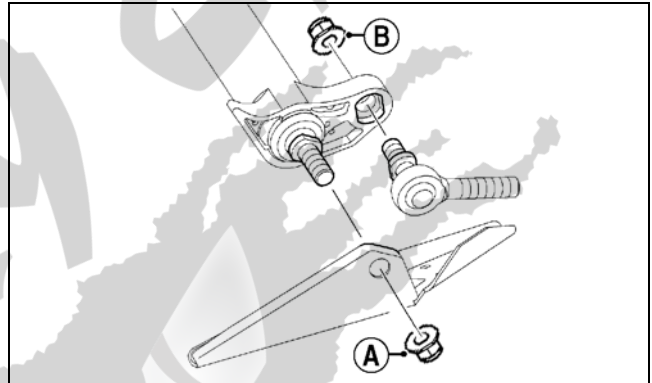

SNO-2221A

7. Remove the cap screws and handlebar caps securing the handlebar to the top of the handlebar riser; then remove the two torx-head screws and nuts securing the top of steering post to the chassis. Account for both steering post blocks and retaining plate.

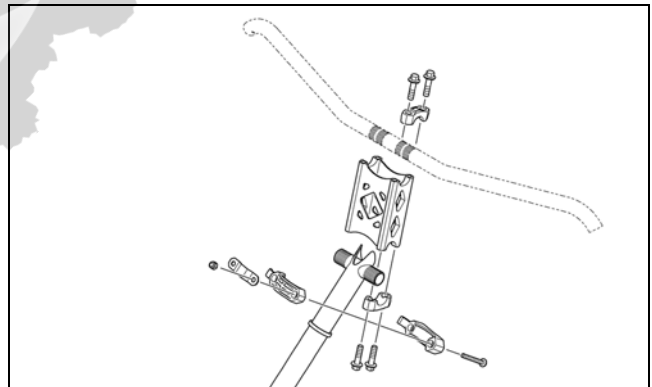

SNO-357

8. Carefully remove the steering post from the snowmobile.

INSTALLING

1. Install steering post into position and secure to the steering stop bracket with a new M10 nut. **Be sure to align the steering post ball joint alignment tab with the steering stop bracket.** Tighten to 43 ft-lb.

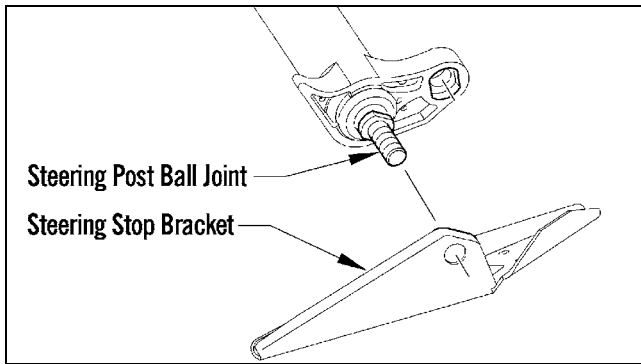

SNO-2218

2. Secure the tie rod assembly to the steering post using a new M10 nut. **Be sure to align the tie rod ball joint alignment tab with the steering post.** Tighten to 35 ft-lb.

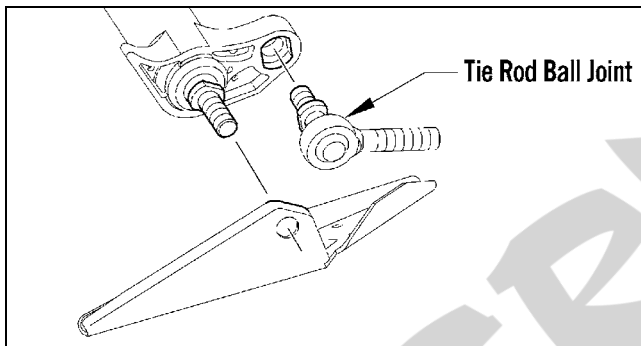

SNO-2219

3. Secure the right-side steering boot to the chassis using the existing push rivets.

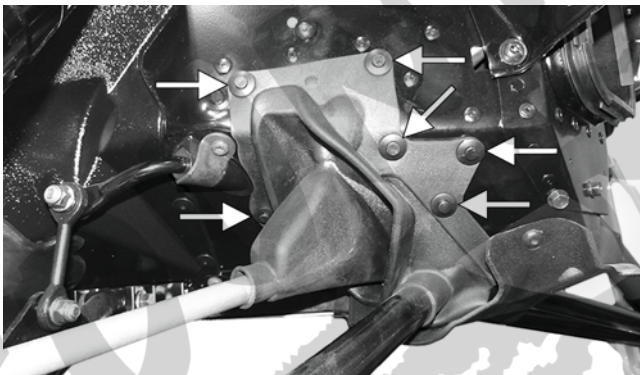

XM134A

4. Secure the top of the steering post to the steering support using the existing retaining plate and nuts. Tighten to 96 in.-lb.

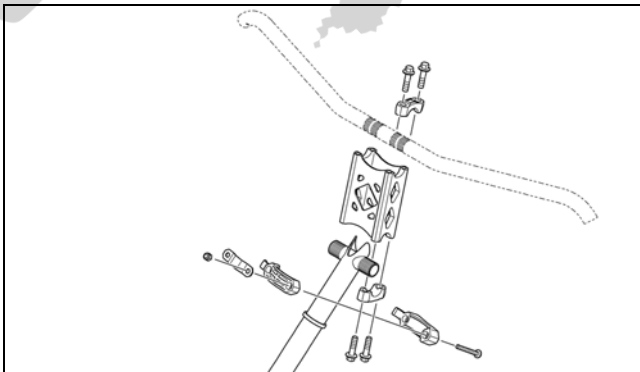

SNO-357

5. Install the expansion chamber using the existing springs; then connect the exhaust temperature sensor to the main harness.
6. Position the hood onto the snowmobile and connect the hood harness connector.
7. Secure the hood with the six torx-head screws and tighten securely.
8. Install the access panels onto the lower console; then close the access panels and secure with the clip.

Steering Post (XF HC/M)

REMOVING

1. Remove the hairpin clip from the pin located at the front of the access panel; then unscrew the thumb screw. Move the panel up and off the pin; then swing the panel all the way out and unhinge the panel from the lower console.

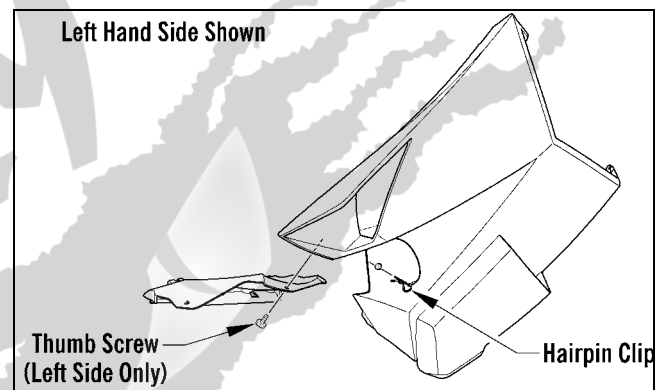

0746-800

2. Remove all six torx-head screws securing the hood.

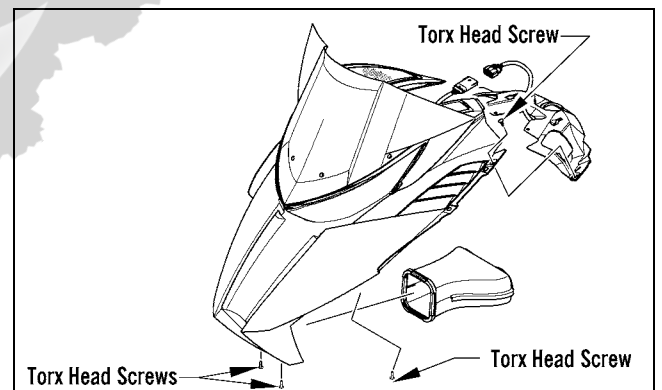

0746-793

3. Locate the hood harness connector (located under the center vent between the intake vents) and unplug the connector; then move the hood slightly forward and remove the hood.
4. Disconnect the exhaust temperature sensor from the main harness; then remove all springs securing the expansion chamber. Remove the expansion chamber.
5. Remove the push rivets securing the right-side steering boot to the chassis. This allows access to the two nuts securing the bottom of the steering post.

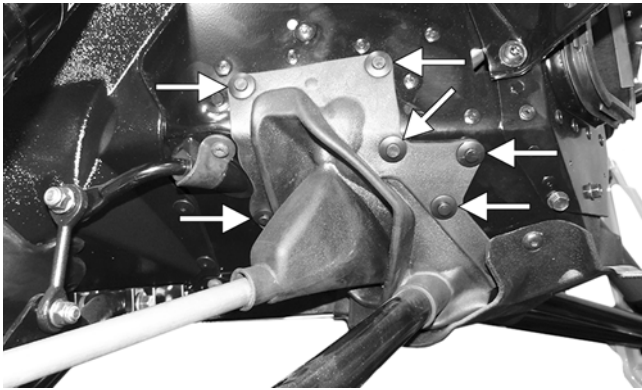

XM134A

- Remove the nut (A) securing the bottom of the existing steering post to the steering stop bracket; then remove the nut (B) securing the steering tie rod assembly to the steering post. Discard both nuts.

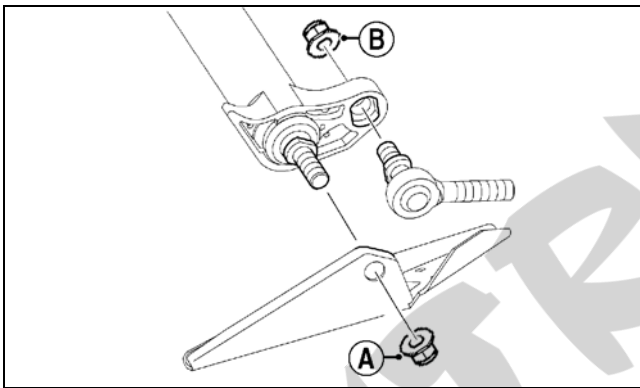

SNO-2221A

- Remove the torx-head screw and nut securing the tie rod link to the secondary steering post; then remove the two machine screws and nuts securing the top of the secondary steering post to the chassis. Account for both steering post blocks and retaining plate.

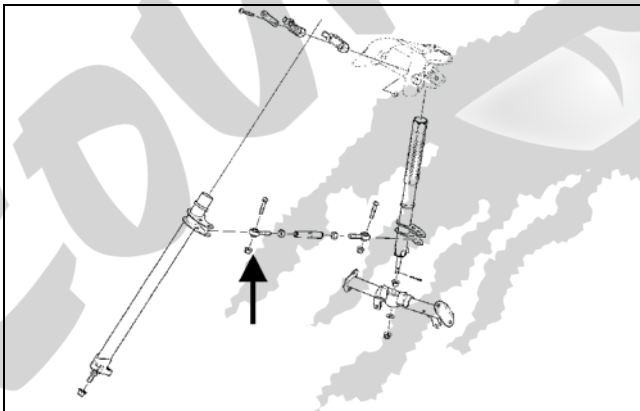

SNO-2226B

- Carefully remove the secondary steering post from the snowmobile.
- Remove and discard the cotter pin (C) and nyloc nut (B) securing the steering post to the lower steering support bracket. Account for a thrust washer (A).

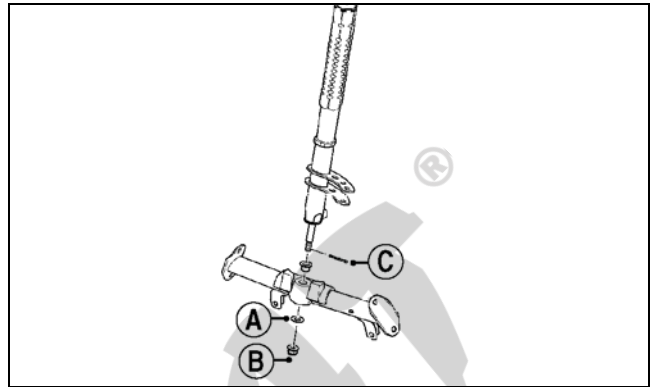

SNO-2225A

- Remove the two cap screws securing the existing steering support (C) to the front spar tubes (B); then remove the two cap screws securing the steering support to the side support tubes (A). Retain all cap screws and nuts.

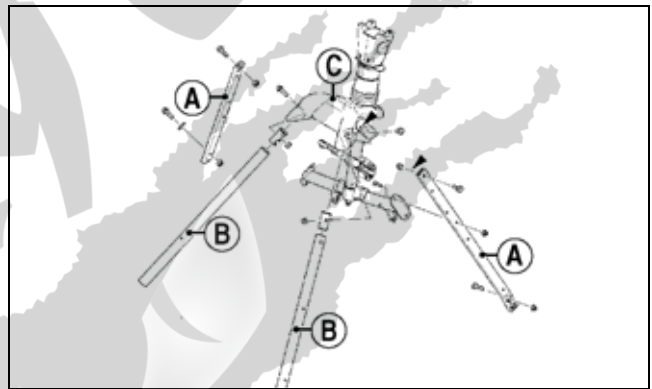

SNO-2227A

- Remove the two cap screws securing the rear portion of the steering support to the rear spar tubes.

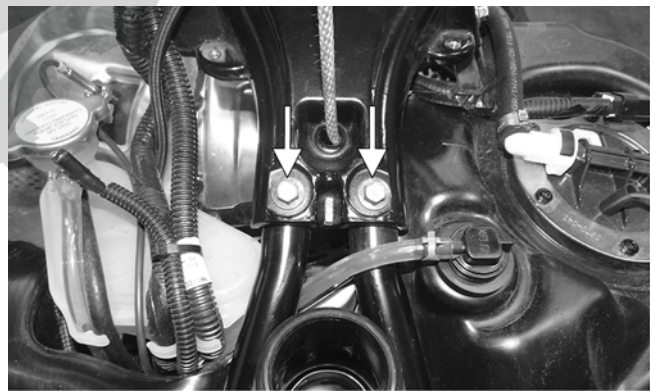

XM212A

- With the telescoping steering assembly removed from the snowmobile; press down on the adjusting block until the inner snap ring is exposed. Remove the snap ring.

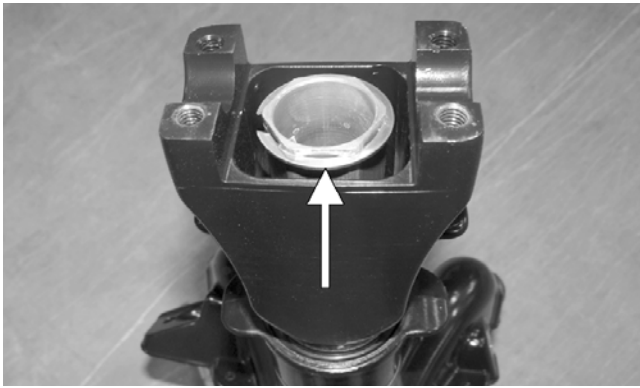

SNO-739A

13. Remove the retaining ring securing the bottom side of the steering post; then remove the post from the steering support. Account for two bearings.



SNO-740A

INSPECTING

1. Inspect all welded areas for cracks or deterioration.
2. Inspect the steering post and steering-post retaining plate for cracks, bends, or wear.
3. Inspect the adjuster caps and mounting block for cracks or wear.

INSTALLING

1. Insert the telescoping steering post into the steering support along with two bushings; then secure the steering post using the existing retaining ring.



SNO-740A

■NOTE: Verify the bushings are properly oriented (the seam should be centered front to back).

2. Install the adjusting block onto the steering post and secure using the existing snap ring.

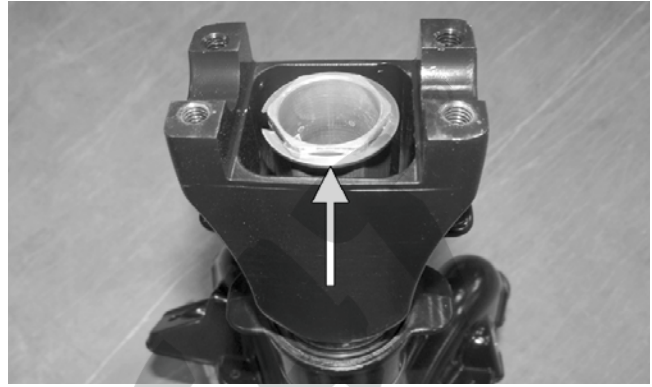

SNO-739A

3. Install the steering post assembly onto the front and rear spar tubes and into the thrust washer (A) and the lower steering post support. Secure with a new nyloc nut (B) and a new cotter pin (C). Tighten to 20 ft-lb and spread the cotter pin to secure.

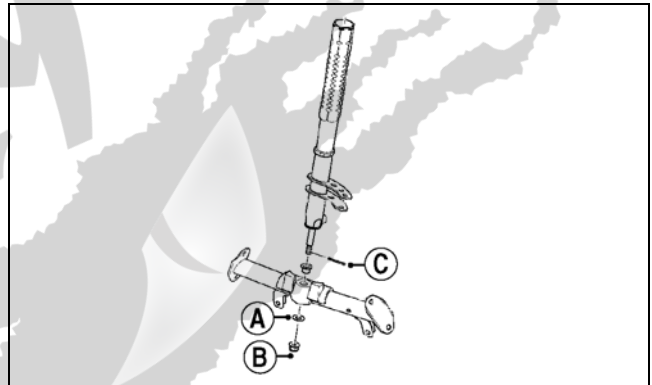

SNO-2225A

4. Secure the steering support to the front and rear spar tubes using the existing cap screws. Tighten to 25 ft-lb.
5. Install the secondary steering post into position and secure to the steering stop bracket with a new M10 nut. **Be sure to align the steering post ball joint alignment tab with the steering stop bracket.** Tighten to 43 ft-lb.

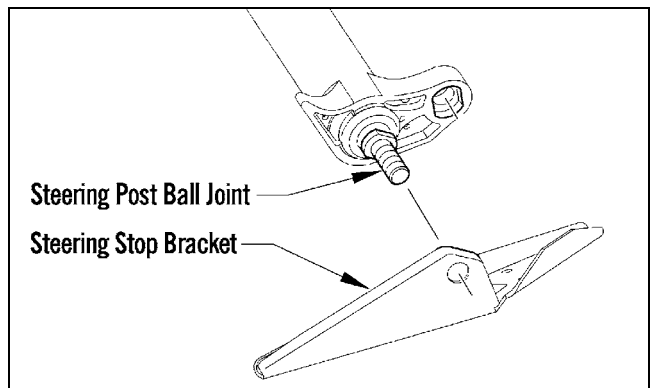

SNO-2218

6. Secure the tie rod assembly to the steering post using a new M10 nut. **Be sure to align the tie rod ball joint alignment tab with the steering post.** Tighten to 35 ft-lb.

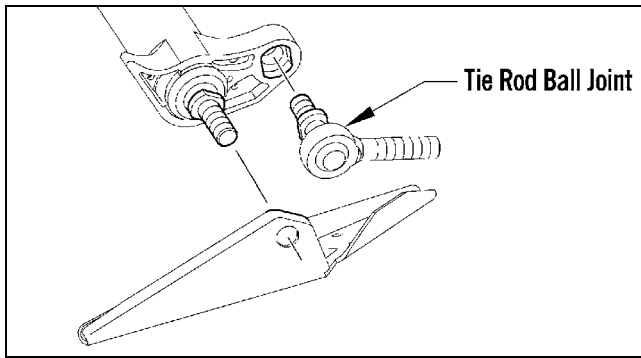

SNO-2219

- Secure the right-side steering boot to the chassis using the existing push rivets.

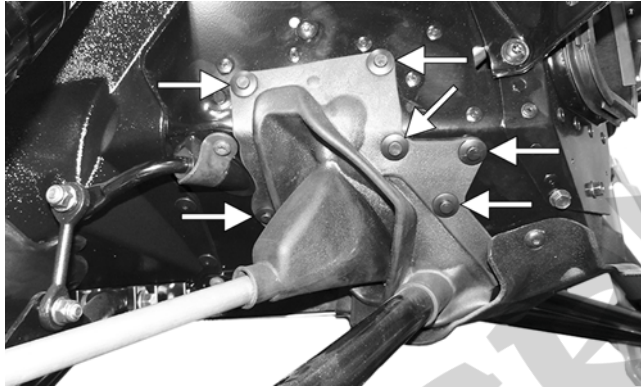

XM134A

- Secure the top of the steering post to the steering support using the existing retaining plate and new nuts (A). Tighten to 96 in.-lb.

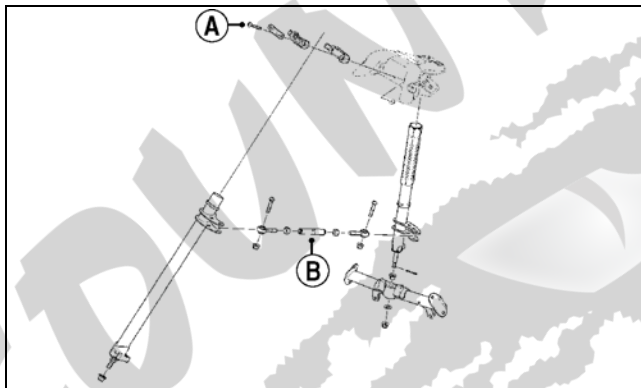

SNO-2226A

- Connect the tie rod (B) from the adjustable steering post to the secondary steering post using the machine screw and nut. Tighten to 20 ft-lb.
- Install the expansion chamber using the existing springs; then connect the exhaust temperature sensor to the main harness.
- Position the handlebar to the desired position; then secure using the existing cap and all eight screws. Tighten evenly to 15 ft-lb.

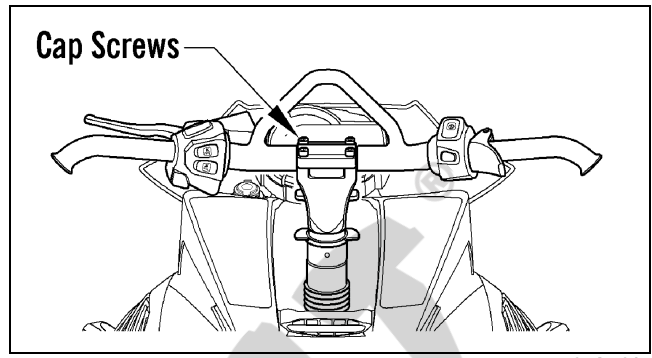

0747-617

- Install the upper and lower console; then install the gas tank and seat using the existing hardware.
- Install the hood and both access panels.

Ski

REMOVING

- Elevate the front of the snowmobile and secure on a support stand.
- Remove and discard the cotter pin; then remove the nut and cap screw securing the ski to the spindle.

■NOTE: Note the orientation of the damper for installation purposes.

- Remove the ski. Account for the rubber damper and washers.

INSPECTING

- Inspect the ski for cracks or deterioration.
- Inspect the ski for abnormal bends or cracks.
- Inspect the wear bar for wear.
- Inspect all hardware and the spindle bushings for wear and damage.
- Inspect the rubber damper for damage or wear.

INSTALLING

- Slide a washer onto the cap screw used to secure the ski; then apply all-temperature grease to the shaft portion of the cap screw and spindle axle.
- Install the spindle axle into the spindle; then position the ski damper into the bottom of the ski making sure the damper is properly positioned for the desired ski stance.

■NOTE: On the ZR 4000 RR, there are two spacers installed onto the spindle axle.

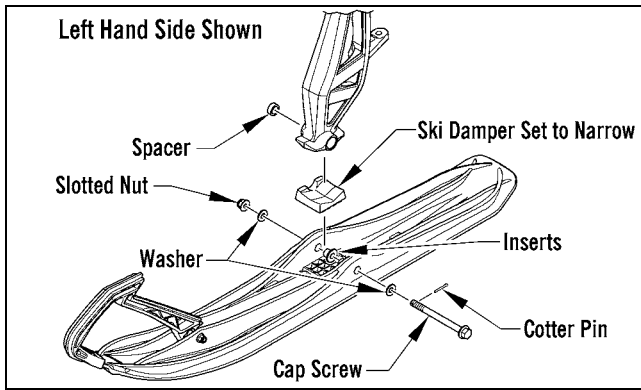

0746-796

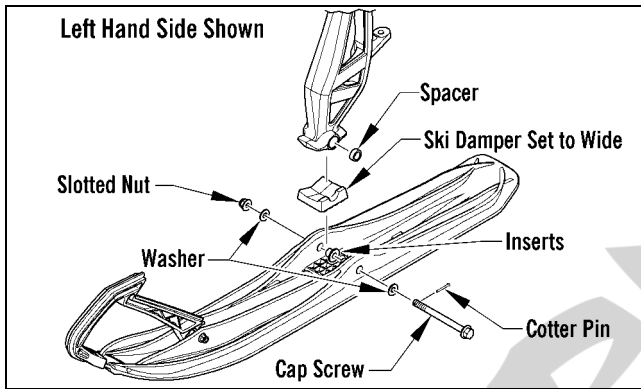

0746-797

■NOTE: The ski damper must be positioned in the ski so it is directly under the spindle.

3. With the cap screw hole of the ski centered with the spindle axle, slide the cap screw with washer through the outside of the ski and spindle assemblies.

■NOTE: Local laws and/or regulations as to maximum width of the ski stance may be applicable. Always comply with the maximum width laws and/or regulations when adjusting ski stance.

■NOTE: Install the cap screw so the lock nut will be located to the inside of the ski and the cotter pin slot in the cap screw will be horizontal with the ski.

4. Install the remaining washer and lock nut; then tighten the lock nut to 35 ft-lb.

■NOTE: Assure that the cotter pin slot in the cap screw is still horizontal with the ski (see illustration); then proceed to step 5.

5. Install a new cotter pin from the back side of the ski cap screw and spread the pin.

Ski Wear Bar

The ski wear bar is a replaceable bar attached to the underside of the ski. If the snowmobile is operated primarily in deep snow, ski wear bar wear will be minimal; however, if the snowmobile is operated on terrain where the snow cover is minimal, the ski wear bar will wear faster. Arctic Cat recommends that the ski wear bars be replaced if worn to 1/2 of original diameter.

REMOVING

1. Raise the front of the snowmobile and secure with a suitable stand.
2. Remove the lock nuts securing the wear bar to the ski; then remove the wear bar.

INSTALLING

1. Install the wear bar into the ski making sure it is fully seated using a rubber mallet.
2. Secure the wear bar with lock nuts. Tighten to 96 in.-lb.

Spindle

REMOVING

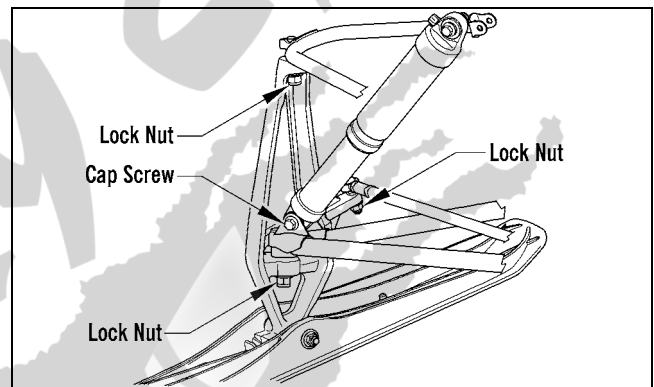

0747-904

1. Position the front of the snowmobile on a safety stand; then remove the ski.
2. Remove the cap screw and lock nut securing the shock absorber to the spindle.
3. Remove the lock nut securing the tie rod to the spindle arm. Account for the washer on the top side.
4. Remove the two lock nuts securing the spindle to the upper and lower A-arms; then using a rubber mallet, remove the arms from the spindle.
5. Remove the spindle.

INSPECTING

1. Inspect the spindle for excessive wear, cracks, bends, or imperfections.
2. Inspect the A-arm bushings and axle area for wear.
3. Inspect the ski spindle axle and bearings for wear, damage, or loose fit. Replace the bearings as a set.

■NOTE: Replacing the ski bolt bushings is difficult. The existing bushings will be damaged during removal. Be careful, however, not to damage the spindle when removing the bushings. Press the new bushings into the spindle.

INSTALLING

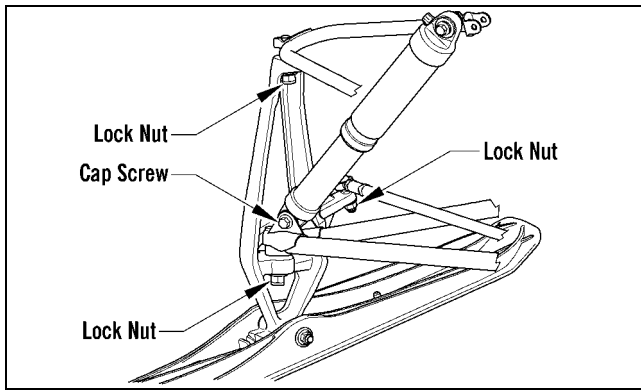

0747-904

1. Place the shock absorber into position on the spindle. Secure with the cap screw and lock nut. Tighten to 32 ft-lb for ZR and XF models. Tighten to 24 ft-lb for M models.
2. Install the upper and lower A-arms into the spindle; then remove the snowmobile from the support stand. Secure with new lock nuts. Tighten to 45 ft-lb.

■ **NOTE:** The weight of the snowmobile will allow the ball joints to seat into the spindle before tightening the nuts.

3. Place the tie rod with washer into position on the spindle arm. Secure with a new lock nut. Tighten to 32 ft-lb.
4. Install the ski.
5. Turn the handlebar fully to the right and then to the left to verify the steering moves freely.

Steering Tie Rod

■ **NOTE:** To access the steering arm, the steering tie rods must be removed.

REMOVING

1. Remove both machine screws and nyloc nuts securing the steering tie rod ends to the steering arm. Discard both nuts.

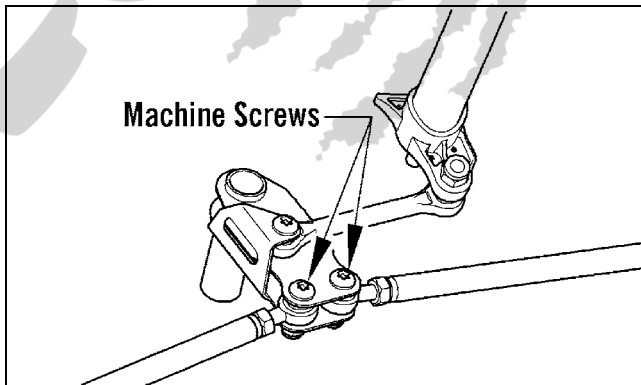

SNO-349

2. Remove the nyloc nuts securing the steering tie rod ends to the spindle arms. Account for the washers and discard both nuts.

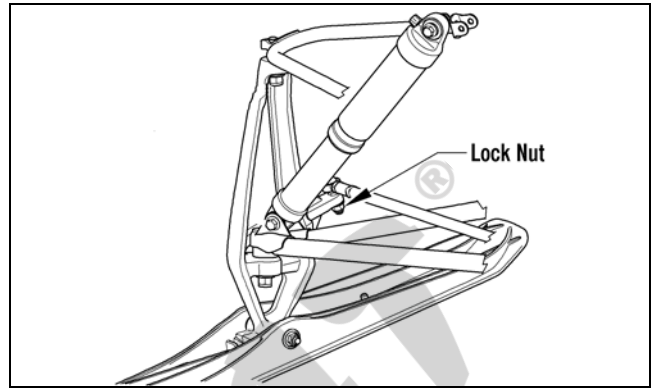

SNO-353

3. Slide the steering tie rod out of the steering boot and out of the snowmobile.
4. Remove the screw and lock nut securing the steering tie rod end to the steering arm. Discard the nut.

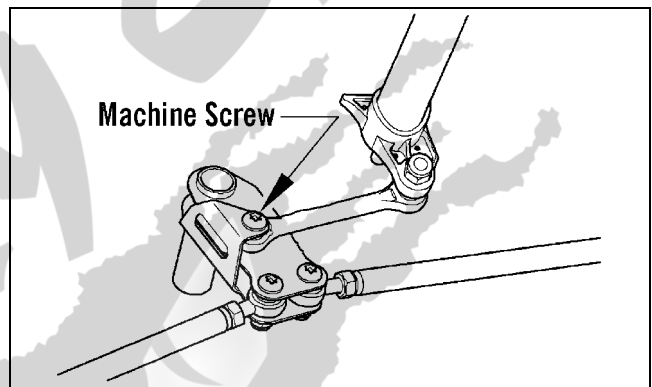

SNO-350

5. Remove the lock nut securing the steering tie rod to the steering post. Discard the nut.

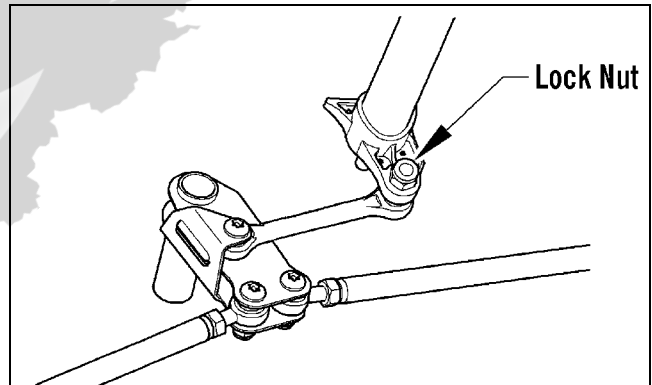

SNO-351

■ **NOTE:** At this point if the technician's objective is to remove the steering arm, the reinforcement bracket will need to be removed by drilling out the appropriate rivets.

6. Remove all torx-head screws securing the front skid plate to the chassis; then remove the cap screw and nut securing the steering arm to the chassis. Account for two washers and two bushings.

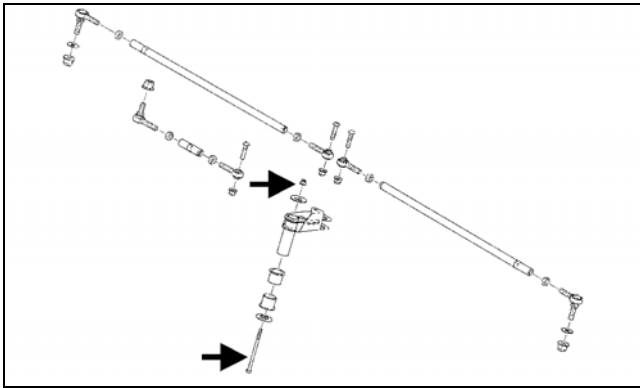

SNO-225A

INSPECTING

1. Inspect the ball joints for damaged threads or wear.
2. Inspect the tie rod for damage, unusual bends, or wear.

INSTALLING

1. Secure steering arm into position and secure using the existing cap screw, flat washers, and nut. Tighten to 96 in.-lb.

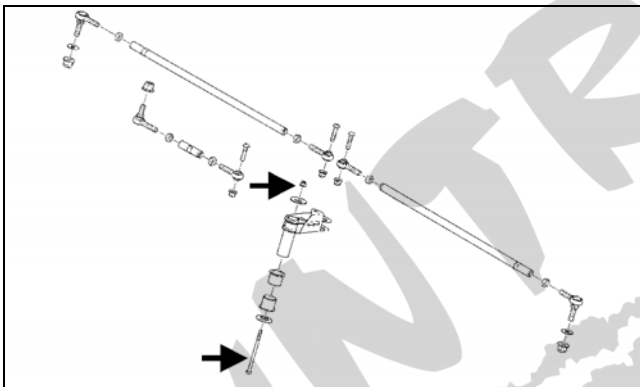

SNO-225A

2. Place the steering tie rod into position on the steering post. Secure with a new nyloc nut. Tighten to 35 ft.-lb.

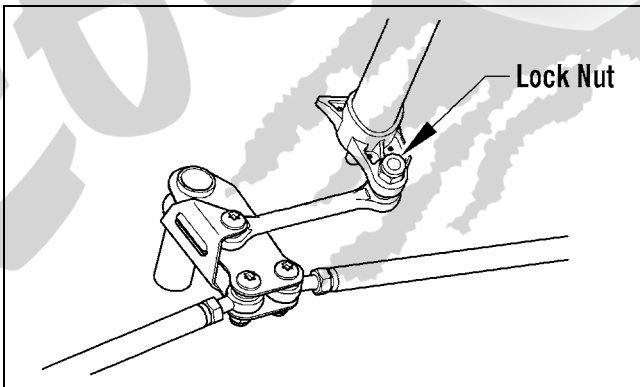

SNO-351

■NOTE: Make sure the tie rod tab is fully seated into the steering post and threads of the ball joint are above the nut when tightened correctly.

3. Place the tie rod end into position on the steering tie rod bracket. Secure with a new nyloc nut. Tighten to 20 ft.-lb.

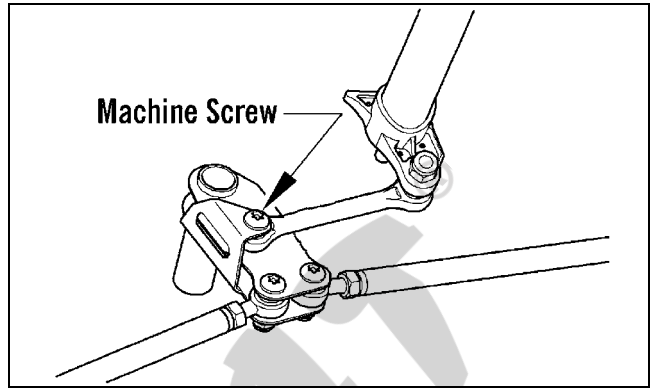

SNO-350

4. Slide the steering tie rod through the steering boot and into the snowmobile; then place the steering tie rod into the spindle arm with the washer. Secure with a new nyloc nut. Tighten to 32 ft.-lb.

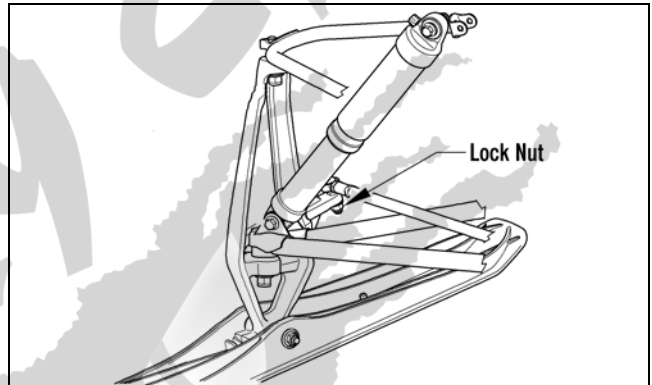

SNO-353

5. Secure the steering tie rod to the steering tie rod bracket with the screw and new nyloc nut. Tighten to 20 ft.-lb.

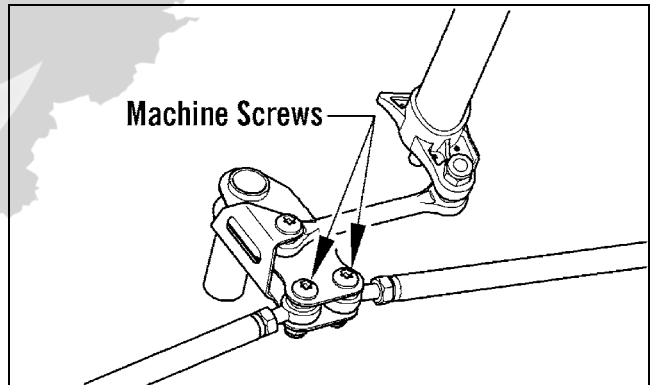

SNO-349

Ski Alignment

CHECKING

■NOTE: Track tension and alignment must be properly adjusted prior to checking or adjusting ski alignment. Ski alignment must be performed on a flat, level surface. Ski toe-out must fall within the range of 1/16-1/4 in.

1. Raise the front end of snowmobile just high enough to keep the skis from contacting the floor.

- Turn the handlebar to the straight-ahead position. Visually inspect the handlebar for being centered and in the straight-ahead position.
- With the handlebar in the straight-ahead position, secure the handlebar to prevent the alignment from becoming disturbed during the remainder of the alignment procedure.

■NOTE: Track tension and alignment must be properly adjusted prior to placing the straightedge against the outside edge of the track.

- Place a long straightedge against the outside edge of the track so it lies near the inside edge of the left-side ski.

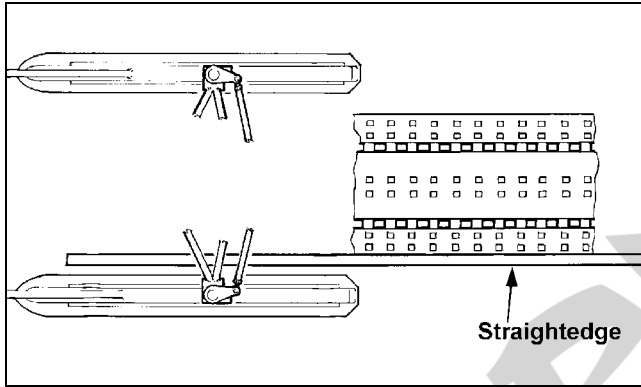

729-887B

■NOTE: The straightedge should be long enough to extend from the back of the track to the front of the ski.

- Measure the distance from the straightedge to the left-side ski wear bar bolts in two places: approximately 7-8 in. in front of the spindle and 7-8 in. behind the spindle. Record the measurements taken for the left side.

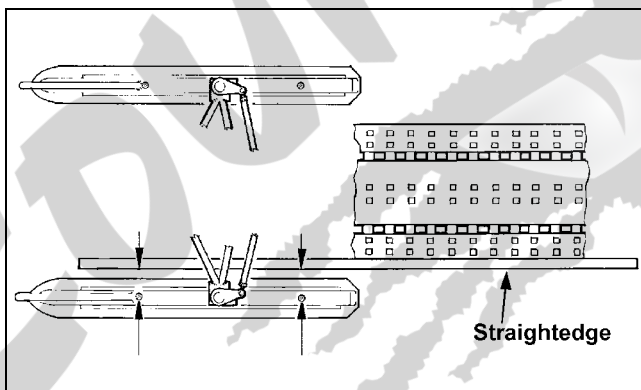

729-887A

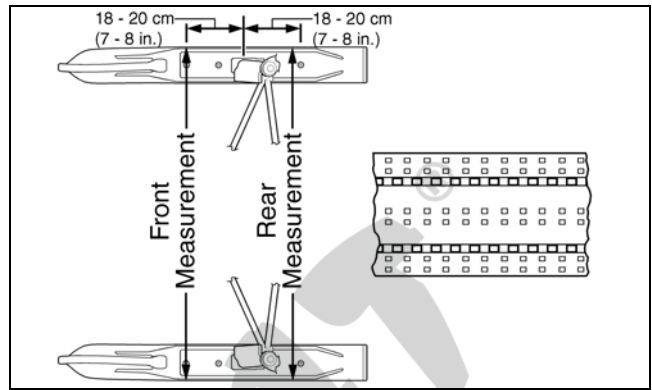

0734-408

- Place the straightedge against the outside edge of the track so it lies near the inside edge of the right-side ski.
- Measure the distance from the straightedge to the right-side ski wear bar bolts in two places: 7-8 in. in front of the spindle and 7-8 in. behind the spindle. Record the measurements taken for the right side.

⚠ WARNING

The measurement from the front and rear wear bar bolts to the straightedge can be equal (ski parallel to the track), but the front measurement must never be less (ski toed-in) or poor handling will be experienced. The front wear bar bolt measurement to the straightedge must not exceed the measurement from the rear wear bar bolt to the straightedge (ski toed-out) by more than 5/32 in.

- If ski alignment is not as specified, adjust the alignment of the ski(s) not parallel to the straightedge.

ADJUSTING

■NOTE: The following procedure can be used to adjust the alignment of either ski.

■NOTE: The rivets securing the steering boots will have to be removed in order to adjust the inner tie rod ends.

- Secure the steering tie rod in the centered position.
- Loosen both spindle tie rod jam nuts on the same side as the ski to be aligned.
- Using a wrench on the spindle tie rod “flats,” rotate the spindle tie rod until recommended specification is attained.
- Apply blue Loctite #243 to each jam nut thread area; then tighten the jam nuts against the spindle tie rod.

■NOTE: Repeat this procedure on each side (if necessary) until ski toe-out is within specification.

⚠ WARNING

Neglecting to lock the tie rod by tightening the jam nuts may cause loss of snowmobile control and possible personal injury.

VERIFYING

1. With the handlebar in the straight-ahead position, verify ski alignment by measuring across from the outside edge of the left-side wear bar bolts to the outside edge of the right-side wear bar bolts (without using the straightedge) in two places: approximately 7-8 in. in front of the spindle and 7-8 in. behind the spindle.
2. The measurement from in front of the spindle to the outer edge of the wear bar bolts (without using the straightedge) must not exceed the rear measurement by more than 1/16-1/4 in. toe-out.

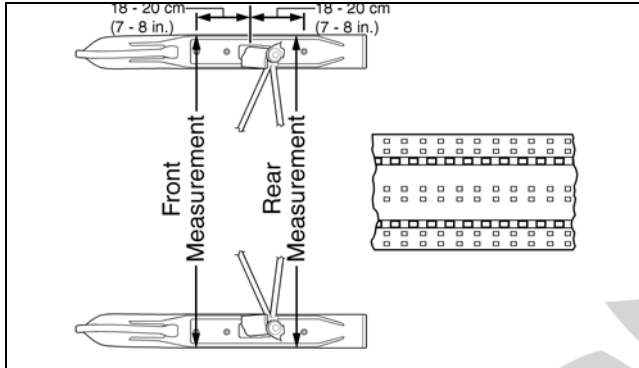

0734-408

⚠ WARNING

The measurement taken in front of the spindle must never be less than the measurement taken behind the spindle or poor handling will be experienced. Neglecting to lock the tie rod by tightening the jam nuts may cause loss of snowmobile control and possible personal injury.

A-Arms

REMOVING

1. Elevate the front of the snowmobile and secure using a suitable support stand.
2. Remove the push rivets securing the steering boot to the chassis; then slide the boot away from the snowmobile.

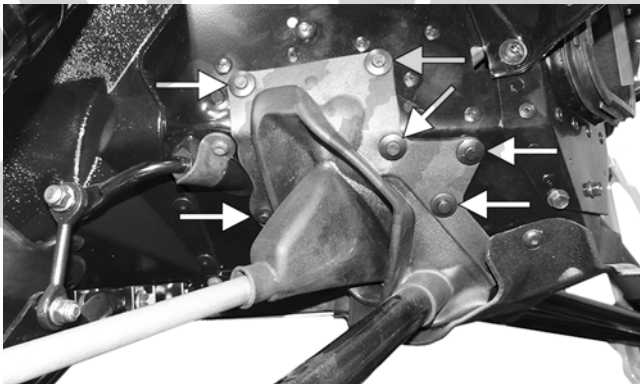

XM134A

3. Remove the torx-head screws securing the front skid plate to the chassis; then remove the front skid plate.
4. Remove the ski shock absorber.

5. Remove the two lock nuts securing the spindle to the A-arms; then using a rubber mallet, remove the arms from the spindle. Discard the nuts.

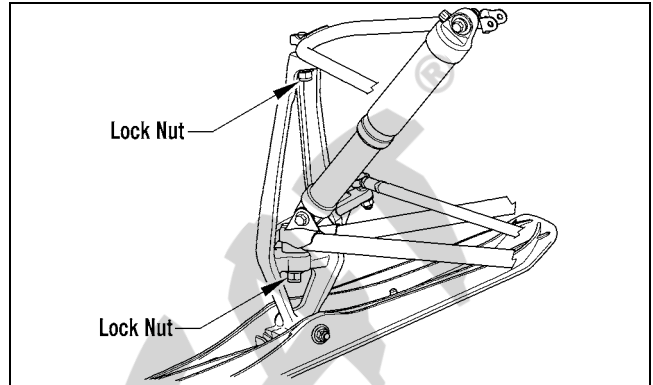

SNO-354

6. On the ZR/XF, remove the cap screw and lock nut securing the sway bar link to the lower arm. Discard the nut.



XM135

7. Remove the two cap screws and nyloc nuts securing the lower arm to the chassis; then slide the boot from the arm and remove the arm.

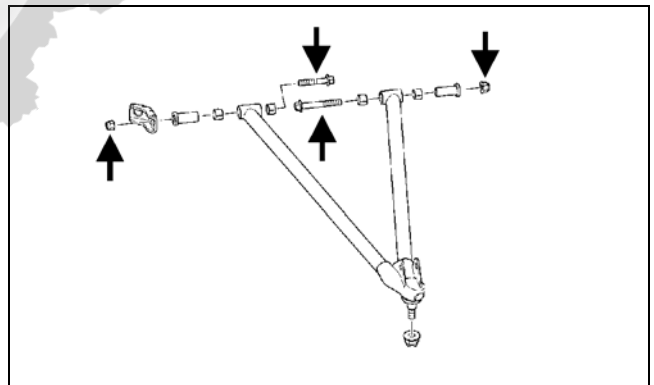

SNO-226A

8. Remove the two cap screws and lock nuts securing the upper arm to the chassis. Discard the nuts.

INSPECTING

1. Inspect the arm welded areas for cracks or any signs of deterioration.
2. Inspect the bearings and axles for wear or damage.
3. Inspect the arm tubing for signs of twisting or bending.

4. Inspect mounting location of the chassis for cracks or wear.

INSTALLING

1. Place the upper arm into position on the chassis and secure with the cap screws and new nyloc nuts. Tighten to 23 ft-lb.
2. Slide the lower arm into the boot; then place the arm into position on the chassis. Secure with the cap screws and new nyloc nuts and tighten to 55 ft-lb (front) and 45 ft-lb (rear).

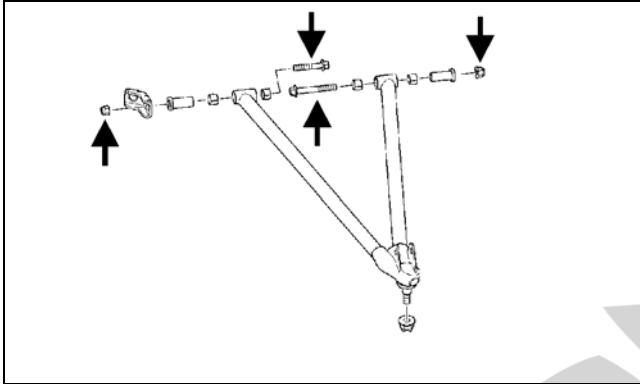

PC095A

3. On the ZR/XF, secure the sway bar link to the lower arm with the cap screw and new nyloc nut. Tighten to 23 ft-lb.



XM135

4. Secure the A-arms to the spindle.
5. Install the ski shock absorber.
6. Place the front skid plate into position; then secure with the torx-head screws.

Ski Shock Absorber

REMOVING

1. Position the front of the snowmobile on a safety stand taking all pressure off the skis.
2. Remove the cap screws securing the shock absorber to the chassis and spindle; then remove the shock absorber. Account for all mounting hardware.

■ **NOTE:** Note the number of threads exposed between the spring adjuster and shock housing for installing purposes.

3. Using the Shock Spring Removal Tool, remove the spring from the shock body by compressing the spring; then remove the spring retainer from the top of the spring. Inspect the shock absorber by quickly compressing and extending the shock plunger while firmly holding the shock body. Resistance must be felt in both directions.

CLEANING AND INSPECTING

1. Inspect the shock absorber seal area for signs of excessive oil leakage.
2. Inspect the shock absorber mounting eyelet, bushings, and sleeve for wear or damage.
3. Inspect the threaded shock sleeve for damage or wear. Clean the sleeve and apply a light coat of grease to the threads before installing.

INSTALLING

1. Using the shock spring tool, place the spring on the shock absorber and secure with the retainer.
2. Adjust the retainer nut (spring adjuster) (if applicable) until the specified amount of threads are exposed between the spring adjuster and the shock housing (noted in removing) as an initial setting.
3. Install the bushings, sleeves, and spacers into each shock end; then place the shock absorber into position and secure with the cap screws and lock nuts. Tighten the lock nuts to 32 ft-lb.

Sway Bar (ZR/XF)

REMOVING

1. Remove the nyloc nuts and cap screws securing the sway bar link to the lower A-arm and the sway bar.



XM135

2. Remove the torx-head screws securing the sway bar mounting brackets; then pull the sway bar out of the snowmobile.

INSPECTING

1. Inspect the sway bar for any signs of twisting, fatigue, or wear.

2. Inspect the sway bar arms for cracks or damage.
3. Inspect the links, bushings, bushing retainers, and hardware for damage or wear.

INSTALLING

1. Place the sway bar into the sway bar mounting brackets; then install the sway bar into the snowmobile. Secure with the torx-head screws and tighten to 96 in.-lb.
2. Secure the sway bar links to the sway bar and lower A-arm with the cap screws and new nyloc nuts. Tighten to 23 ft.-lb.

Front Bumper

REMOVING/INSTALLING

1. Remove all torx-head screws securing the front bumper; then remove the bumper.
2. With the bumper in position, install all torx-head screws. Tighten securely.

Seat Assembly (ZR/XF/M STD)

REMOVING/INSTALLING SEAT

■NOTE: On LXR/LTD models, be sure to disconnect the seat heater harness before removing the seat.

1. Remove the cap screw securing the rear of the seat; then remove the seat.

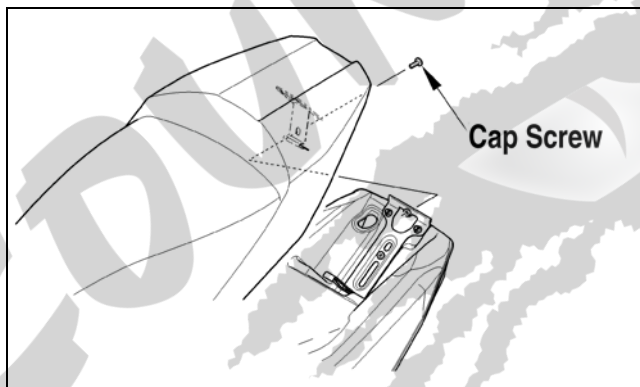

SNO-261A

2. Route the front tab on the seat through the seat-base hold-down bracket; then install the seat and secure using the cap screw.

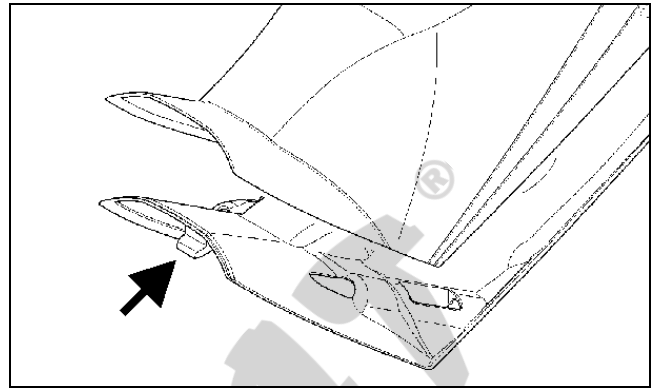

SNO-227A

■NOTE: On LXR/LTD models prior to lowering and securing the seat, connect the seat heater harness connector.

REMOVING CUSHION

1. Remove the seat assembly.
2. Using a sharp tool, pry out all staples securing the seat cover to the plastic seat base.
3. From beneath the seat foam, remove the seat wire from the two elastic loops; then remove the cover from the seat base and seat foam.

INSTALLING CUSHION

1. Position the cover over the seat foam and seat base; then pull the two elastic loops through the slots in the seat foam and secure with the seat wire. Check to make sure it is positioned straight.
2. Fold the rear edge of the cushion down and around the plastic base. Using a staple gun and 1/4 in. staples, staple the rear flap of the cushion to the plastic base in the same areas as the original staples were located. Position staples 1 in. apart.
3. Fold the sides of the cushion down around the bottom edge of the plastic seat base. Position the staples in the same area as the original staples were located.

■NOTE: Note the cushion fit. If any wrinkles are noted, remove by pulling the cushion material in the appropriate direction before securing with staples.

4. Fold the front cushion material back and onto the plastic seat base. Check for wrinkles and secure with staples and two screws.
5. Install the seat assembly.

Seat Assembly (M Sno Pro/HCR/LTD)

REMOVING/INSTALLING

1. Remove both torx-head screws from the side of the seat; then remove the four tabs from the seat base from the lower console. Pull back and remove the seat cover and foam.

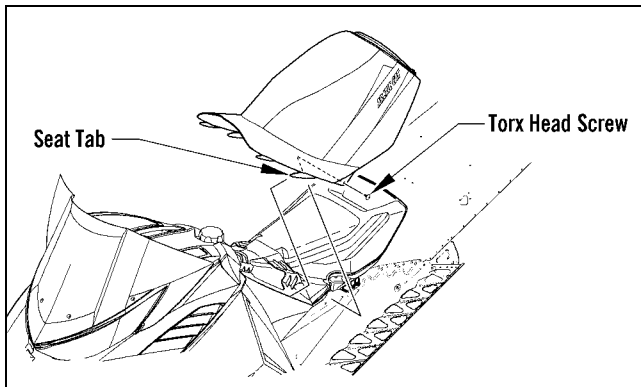

0747-530

2. Position the seat foam into the seat cover by first aligning the front of the foam with the front of the seat base/cover (A); then wrap the rear of the seat base/cover over the rear of the seat foam (B). Cover the sides of the seat foam with the seat base/cover and secure using the velcro strap.



SNO-1203A

3. Remove the backing from the installation bag (p/n 1655-841); then adhere it to the gas tank making sure the bag covers the velcro on the gas tank.



SNO-1206

4. Slide the rear of the seat cover with foam over the rear of the gas tank; then slide the four tabs into the four holes in the lower console and secure to the tunnel using two self-tapping screws. Do not over tighten.

■NOTE: To ease the installation of the seat cover, carefully pry up the rear of the gas tank so the seat cover can easily slide around the rear of the gas tank.

Taillight/Brakelight Assembly

1. Remove the two machine screws securing the taillight to the taillight support; then disconnect the taillight harness connector.

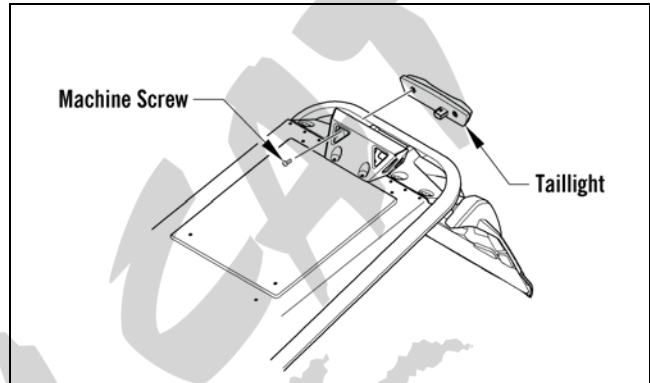

SNO-511

2. Connect the taillight harness connector; then secure the taillight to the taillight support with the two screws. Tighten to 48 in.-lb.

Rear Bumper/Snowflap

REMOVING BUMPER

1. Remove and retain only the two machine screws securing the rear of the skid frame assembly.
2. Place cardboard or a suitable substitute on the floor to protect the snowmobile from being scratched; then install Steering Post Stand for the standard steering models or Handlebar Stand for the adjustable steering models into the lower holes in the handlebar riser (from the left-side) and tip the snowmobile onto its left side.

CAUTION

The stand must be used when tipping the snowmobile onto the right side. Failure to use the stand may damage the oil fill neck.

3. Swing the skid frame assembly away from the chassis; then using a 3/16-in. drill bit, remove all rivets securing the left-side of the bumper; then repeat for opposite side.
4. Remove and retain the two machine screws and nuts securing the front of the existing bumper to the chassis.
5. Remove the two rivets securing the snowflap to the bumper. Remove the bumper.

INSTALLING BUMPER

1. Align the holes in the bumper with the existing holes in the tunnel; then using new rivets, secure rear bumper to the tunnel; then secure the snowflap to the rear bumper using new rivets.

- Secure the front of the bumper to the chassis using the existing machine screws and nuts. Tighten securely.
- Install skid frame assembly using two existing machine screws. Tighten securely.

REMOVING SNOWFLAP

- Drill out the four rivets securing the snowflap to the tunnel; then remove the torx-head screw and nut.
- Remove the snowflap.

INSTALLING SNOWFLAP

- Secure the snowflap to the tunnel with the torx-head screw and nut.
- Add the appropriate rivets to secure the snowflap to the tunnel.



PC108

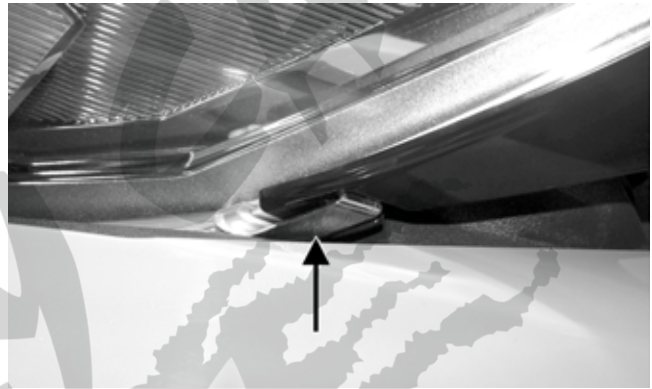

PC106A

Windshield/Console/ Headlight

REMOVING

- Remove and retain all machine screws securing the hood; then disconnect the console harness and carefully remove the hood assembly.
- Remove the four screws securing the windshield to the console; then remove the windshield.
- Remove the four screws securing the windshield brace to the console. Disconnect the gauge; then remove the windshield brace assembly.

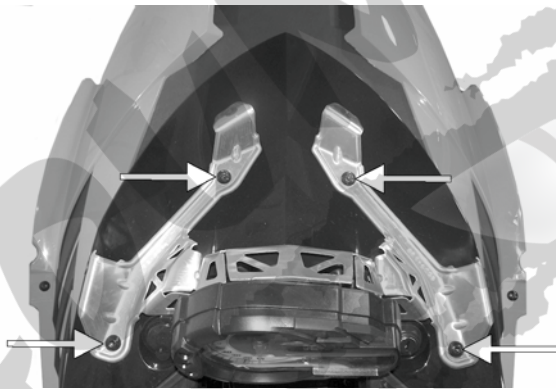

PC104A

- Disconnect the electrical accessory wires and ignition switch.
- Remove the two screws securing the rear of the console to the hood.
- Lift the front of the console from the headlight assembly; then disengage the side console tabs and remove the console.

- Loosen the two side headlight assembly screws (A); then remove the two front headlight assembly screws (B).

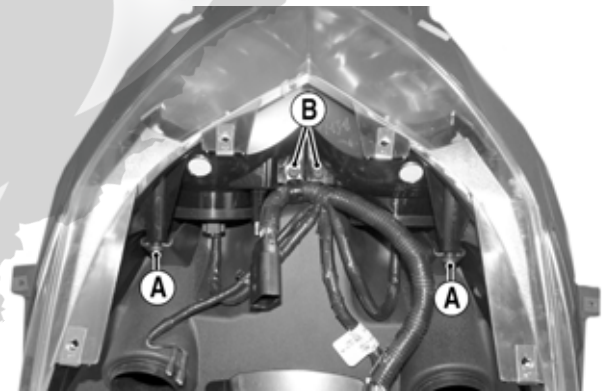

PC107A

- Remove the headlight assembly.

INSTALLING

- With the headlight assembly in position, install the front headlight assembly screws. Engage the side headlight screws in the slots and tighten until snug.
- Engage the side console tabs on the headlight assembly; then place the front of the console over the headlight assembly and press down until it snaps in place.
- Install the two screws securing the rear of the console to the hood. Tighten only until snug.
- Place the windshield brace assembly into position and secure to the console with the four screws. Tighten until snug.
- Connect the gauge; then connect the electrical accessory wires and the ignition switch.

6. With the windshield in position, secure the windshield to the frame using the four screws. Tighten securely.
7. Connect the console harness; then install the hood assembly and secure with the screws.

Headlight Bulb

■**NOTE:** The bulb portion of the headlight is fragile. **HANDLE WITH CARE.** When replacing the headlight bulb, the bulb assembly must first be removed from the housing. Do not touch the glass portion of the bulb. If the glass is touched, it must be cleaned with a dry cloth before installing.

1. Disconnect the headlight harness connector from the bulb; then remove the rubber grommet from the headlight housing.
2. Rotate the bulb retainer counterclockwise until it unlocks from the housing; then remove the bulb.

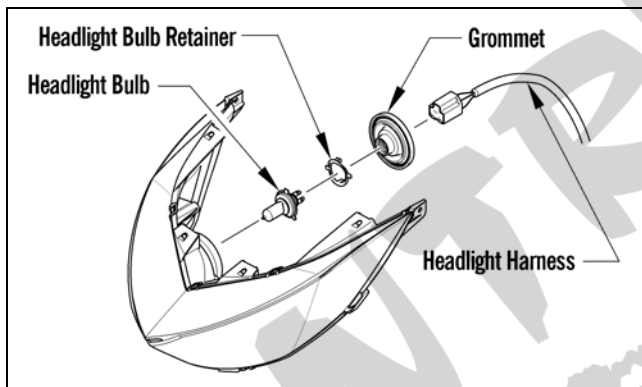

0746-096

3. Install the bulb and retainer; then rotate the retainer clockwise until it properly locks in place.
4. Install the rubber grommet; then connect the headlight harness connector to the bulb.
5. Check headlight aim (see Adjusting Headlight Aim in this sub-section).

WARNING

Do not operate the snowmobile unless headlight beam is adjusted properly. An incorrectly adjusted beam will not provide the operator the optimum amount of light.

Adjusting Headlight Aim

The headlight can be adjusted for vertical aim of the HIGH/LOW beam. The geometric center of HIGH beam zone is to be used for vertical aiming.

1. Position the snowmobile on a level floor so the headlight is approximately 25 ft from an aiming surface (wall or similar surface).

■**NOTE:** There should be an “average” operating load on the snowmobile when adjusting headlight aim.

2. Measure the distance from the floor to midpoint of the headlight.
3. Using the measurement obtained in step 2, make a horizontal mark on the aiming surface.
4. Make a vertical mark intersecting the horizontal mark on the aiming surface directly in front of the headlight.
5. Engage the brake lever lock and start the engine. Select the headlight dimmer switch HIGH beam position. **DO NOT USE LOW BEAM.**
6. Observe the headlight beam aim. Proper aim is when the most intense beam is centered on the vertical mark 5 cm (2 in.) below the horizontal mark on the aiming surface.
7. Adjust the headlight using the adjusting screw on the backside of the headlight housing until correct aim is obtained. Shut the engine off; then disengage the brake lever lock.

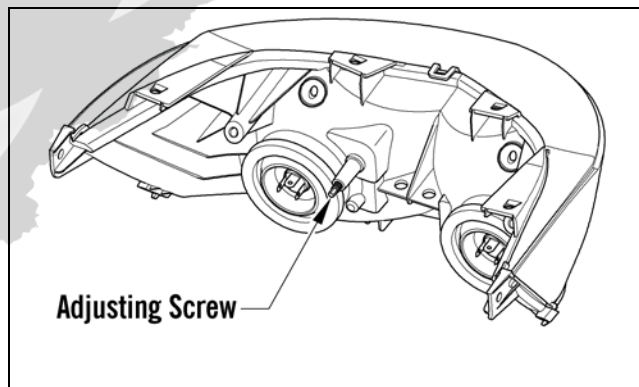

0746-807

Engine

■NOTE: Whenever a part is worn excessively, cracked, or damaged in any way, replacement is necessary.

Engine Removing/ Installing - 4000

This engine sub-section has been organized to show a progression for the removing/installing of the Arctic Cat 4000 engine. For consistency purposes, this sub-section shows a complete and thorough progression; however, for efficiency it may be preferable to remove only those components needing to be addressed. Also, some components may vary from model to model. The technician should use discretion and sound judgment.

SPECIAL TOOLS

A number of special tools must be available to the technician when performing service procedures in this engine section.

Description	p/n
Drive Clutch Bolt Tool	0644-281
Drive Clutch Puller	0744-062
Drive Clutch Spanner Wrench	0644-136
Hood Harness Extension	1686-659

■NOTE: Special tools are available from the Arctic Cat Service Parts Department.

CAUTION

Never attempt to substitute any other drive clutch puller for the recommended puller or severe clutch or crankshaft damage will occur.

Removing

■NOTE: For assembling purposes, note cable tie locations securing the harness and cables to the chassis.

■NOTE: Prior to removing the engine, disconnect the hood harness and remove the side access panels; then remove the screws securing the hood to the chassis.

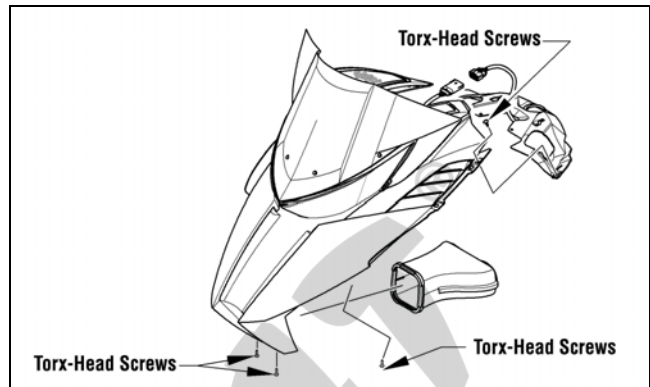

0746-793A

1. Carefully remove the exhaust temperature sensor from the expansion chamber.
2. Remove all springs securing the expansion chamber and resonator; then remove the expansion chamber and resonator.
3. Remove the cap screw from the driven clutch and slide the driven clutch (along with the drive belt) off the driven shaft. Account for alignment washers.
4. Using Drive Clutch Bolt Tool, remove the torx-head screw and high-collar washer securing the drive clutch to the crankshaft.
5. Using Drive Clutch Puller and Drive Clutch Spanner Wrench, tighten the puller. Remove the drive clutch.

■NOTE: If the drive clutch will not release, sharply strike the head of the puller. Repeat this step until the clutch releases.

6. Remove the two screws (A) securing the heat shield to the chassis; then remove the heat shield from the two front locating pins (B) and remove the heat shield.

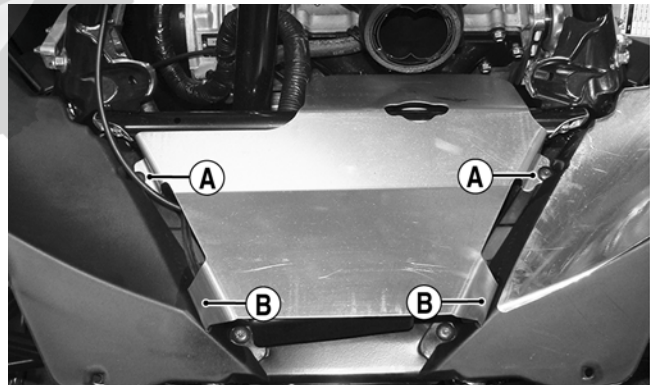

XM250A

7. Disconnect the ECM; then remove the screws securing the right- and left-side fascia panels to the chassis. Remove the panels and ECM as an assembly.

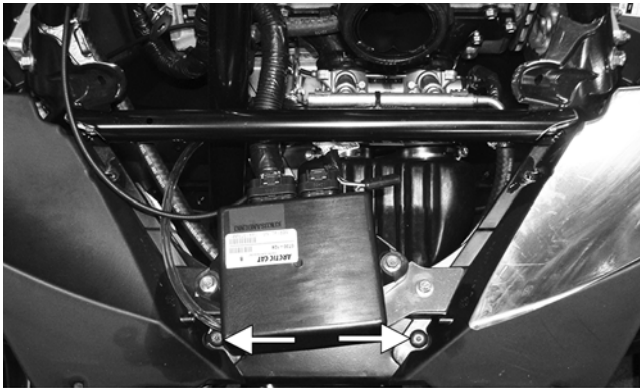

XM251A

8. Remove the cap screws securing the MAG-side front spar to the steering support and shock mount bracket; then remove the spar.

■ **NOTE:** Take care to not drop the spar inserts and nuts when removing the spar.

9. Remove the cap screws and lock nuts securing the shock mount bracket support to the shock mount brackets; then remove the shock mount bracket support.
10. Loosen the clamps securing the intake boot to the throttle body; then remove the intake boot.
11. Loosen the clamps securing the throttle body; then lift up the throttle body and disconnect the coolant hoses. Set the throttle body up and out of the way.

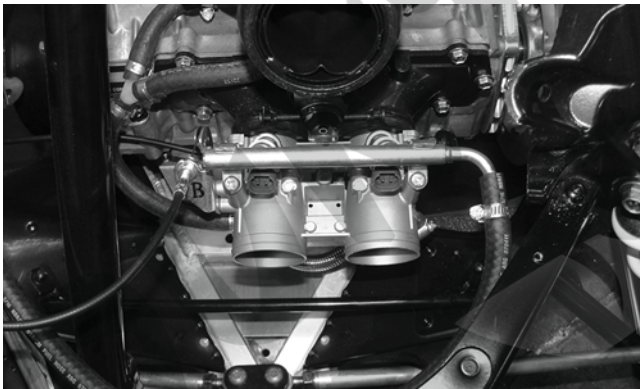

XM252

12. Disconnect the harness connectors. Secure the harness up and out of the way.
13. Remove the recoil starter from the engine. Secure it out of the way.

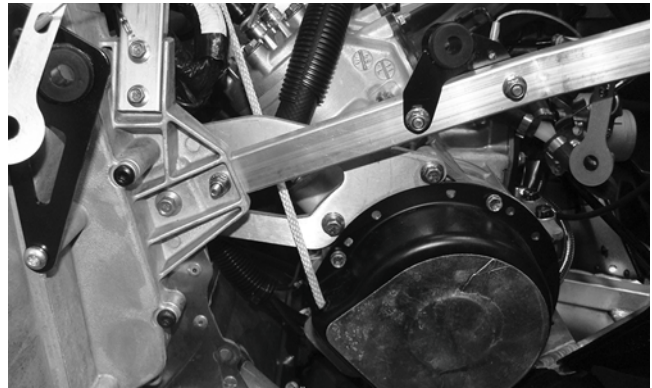

XM252

14. Remove the cap screws securing the MAG-side engine mount to the engine.

15. Remove the spark plug caps from the spark plugs; then remove the cylinder head vent hose.

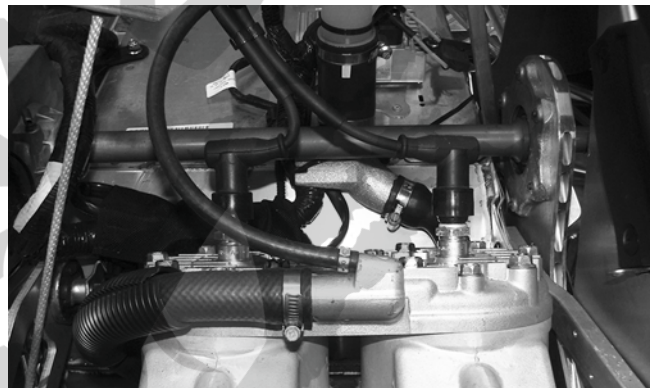

XM255

16. Disconnect the lower coolant hose from the front heat exchanger; then remove the coolant hose from the heat exchanger at the rear of the engine.



XM253A

17. Remove the four screws securing the PTO-side engine mounting plate to the engine.

■ **NOTE:** Before removing the cap screws, apply a sufficient amount of heat to the cap screws to soften the Loctite.

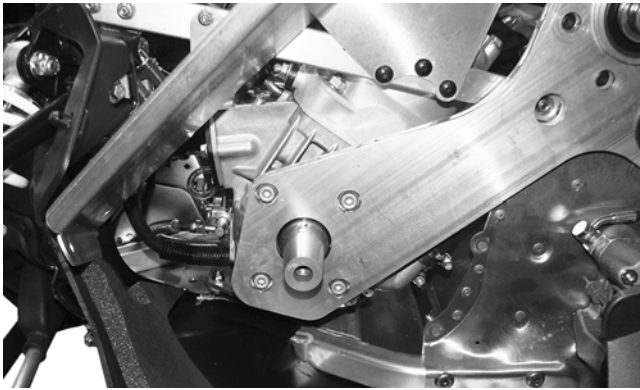

XM257

18. Remove the cap screw and two lock nuts securing the engine support plate to the chassis; then lift the engine out of the engine compartment.

■**NOTE:** If replacing the engine, make sure to remove the engine support plate, exhaust manifold, and coolant hoses for installation on the new engine.

Installing

■**NOTE:** If the engine was replaced, make sure to install the existing engine support plate and the exhaust manifold on the new engine. Tighten the exhaust manifold nuts to 12 ft-lb, the M6 engine support plate cap screws to 25 ft-lb, and the M8 engine cap screws to 35 ft-lb. Install the coolant hoses.

1. Carefully lower the engine into the engine compartment.
2. Install the coolant hose to the heat exchanger at the rear of the engine; then connect the lower coolant hose to the front heat exchanger.

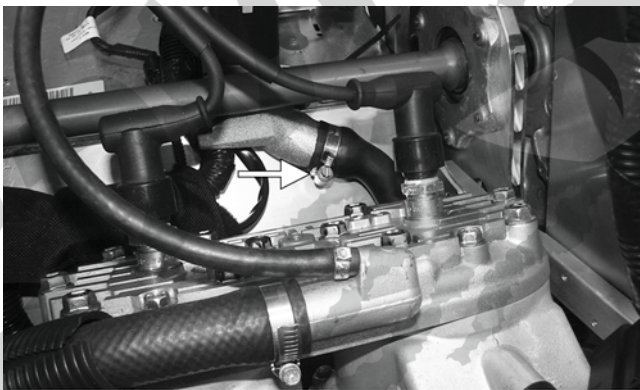

XM253A

3. Install new MAG-side engine mount “patch-lock” cap screws. Finger-tighten only at this time.
4. Install a new “patch-lock” cap screw and new lock nuts to secure the engine support plate to the chassis. Finger-tighten only at this time.
5. Install four new “patch-lock” screws to secure the PTO-side engine mounting plate. Tighten to 30 ft-lb using a crisscross pattern.

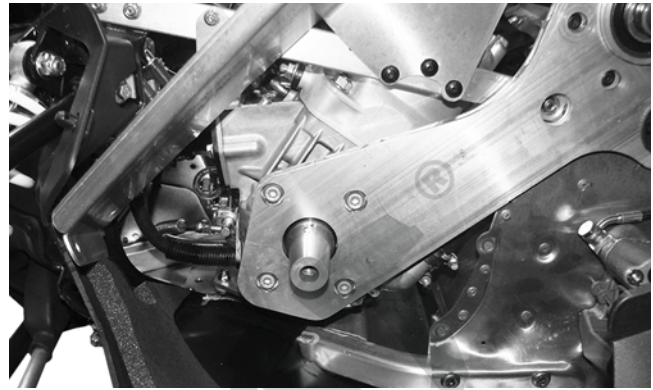

XM257

6. Tighten the cap screw and lock nuts (from step 4) to 25 ft-lb.
7. Install the access panel to the center belly panel and chassis and secure using the torx-head screws. Tighten securely.
8. Tighten the cap screws (from step 3) to 25 ft-lb.
9. Install the spark plug caps; then install the cylinder head vent hose.
10. Place the recoil starter into position and secure with the cap screws. Tighten in a crisscross pattern to 96 in.-lb.
11. Before connecting the wiring harness plug-ins, clean the connectors and apply Dielectric Grease to the seal; then connect all harness connectors making sure all wiring and coolant hoses are routed properly as noted in removing.

■**NOTE:** Use cable ties to secure the wiring harnesses as necessary.

12. Connect the MAG-side throttle body coolant hose; then secure with a clamp.
13. Place the throttle body assembly into position and secure with the flange clamps; then connect the gasoline hose to the throttle body assembly and tighten the clamp securely.

CAUTION

When installing the throttle bodies, make sure the gasoline hose is properly routed to avoid premature wear and/or contact with exhaust components.

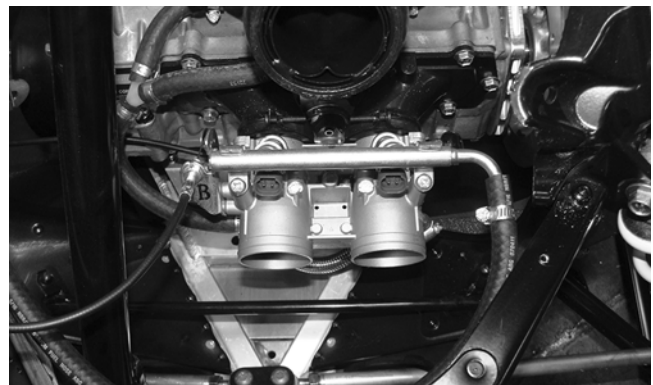

XM252

14. Connect the PTO-side throttle body coolant hose; then secure with a clamp.

15. Fill the cooling system (see Liquid Cooling System in the Engine-Related Items section).
16. Using the existing clamps, secure the intake flanges to the throttle bodies.
17. With the air intake boot properly positioned on the throttle bodies, secure with the existing clamps.
18. Install the shock mount bracket support; then using new lock nuts, secure the support to the shock mount brackets and tighten to 20 ft-lb.
19. Install the MAG-side front spar and secure to the steering post and shock mount bracket using the existing cap screws. Tighten the cap screws to 25 ft-lb.
20. Install the fascia panels (with ECM) and secure to the chassis using the existing screws. Tighten securely. Connect the ECM.

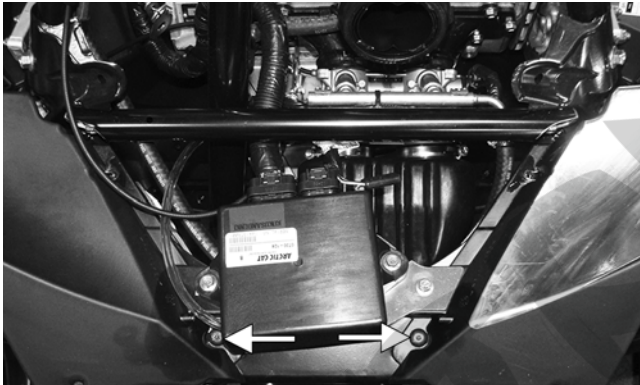

XM251A

21. Position the heat shield onto the two front locating pins (B); then secure it to the chassis with the two screws (A). Tighten securely.

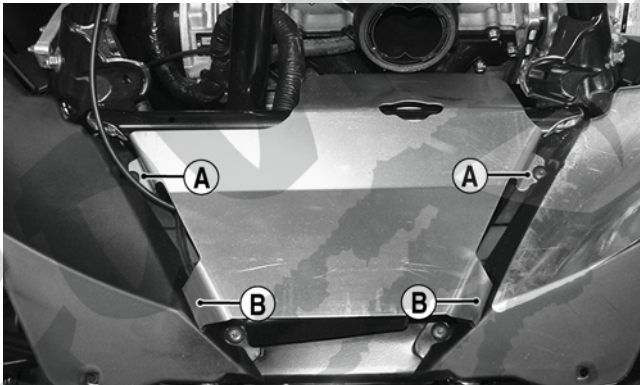

XM250A

22. Install the resonator and secure with the springs; then place the expansion chamber and gaskets into position and secure to the exhaust manifold and resonator with the springs.
23. Place the drive clutch with drive belt into position on the crankshaft and secure with the cap screw (threads coated with oil) and high-collar washer. Tighten to 51 ft-lb.

CAUTION

When installing the drive clutch, do not tighten the clutch cap screw with any kind of impact tool. Tighten cap screw using a hand torque wrench only. Failure to do so could result in stationary sheave damage.

■ **NOTE: Before installing the drive clutch, be sure to wipe both the crankshaft and clutch mounting tapers clean using a clean towel.**

24. Install the driven clutch on the driven shaft; then install the drive belt (see the Drive Train/Track/Brake Systems section).
25. Check drive belt deflection (see the Drive Train/Track/Brake Systems section).
26. Place the hood into position on the front end and secure with the screws; then install the hood harness. Install the side access panels.

CAUTION

Never run the engine with the hood harness disconnected or damage to the electrical system will result.

27. Start the engine and warm up to operating temperature; then verify that all components are functioning properly and that coolant is circulating through the cooling system properly.
28. After running the engine to the proper operating temperature, shut the engine off; then open the access panels and inspect for any signs of coolant, gasoline, or oil leakage.
29. Allow the engine to cool; then check the coolant level and add coolant as necessary. Verify the tightening torque of the drive clutch.

CAUTION

If the engine had a major overhaul or if any major component was replaced, proper engine break-in procedures must be followed (see the General Information section) or severe engine damage may result.

Assembly Schematic - 4000

Torque Specification Tolerances	
Torque (ft-lb)	Tolerance
0-15	±20%
16-39	±15%
40+	±10%

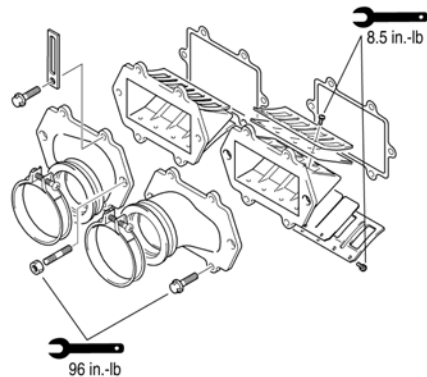
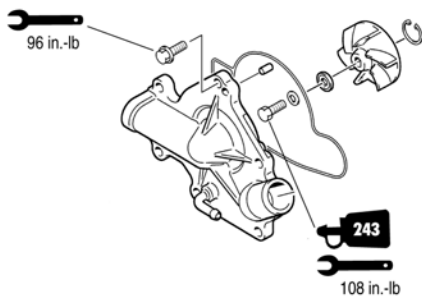
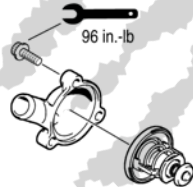
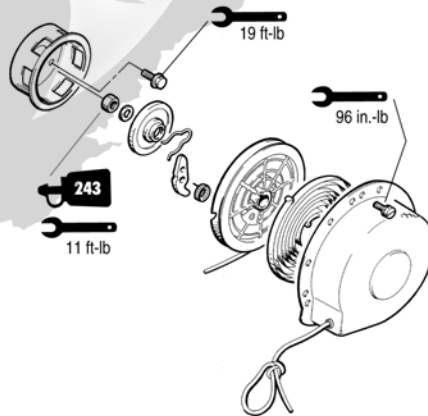
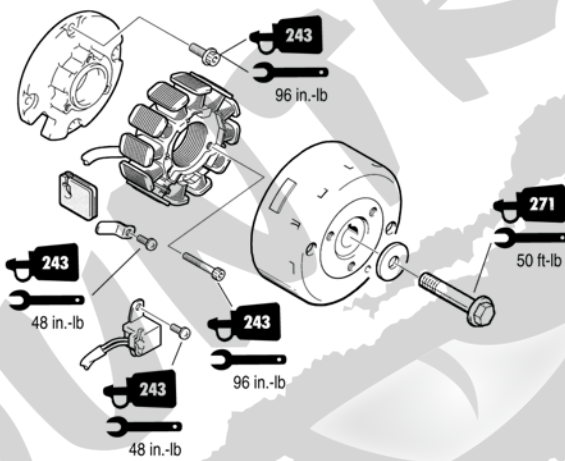
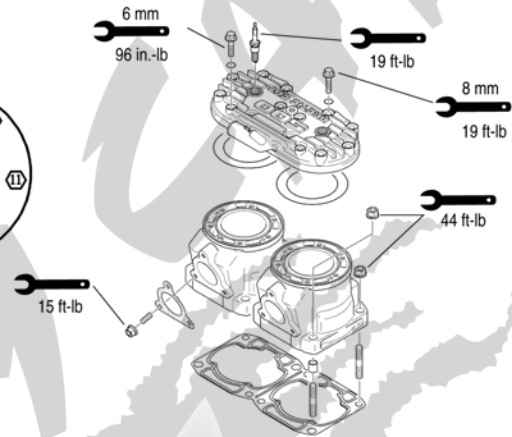
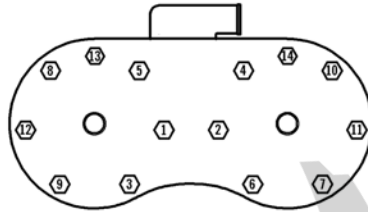
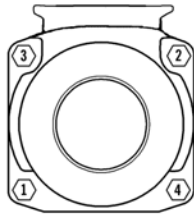

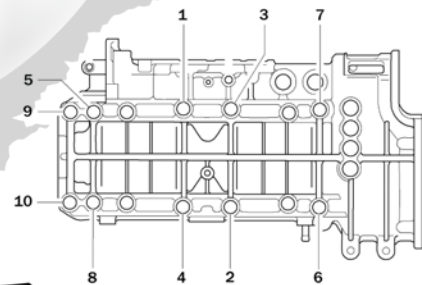
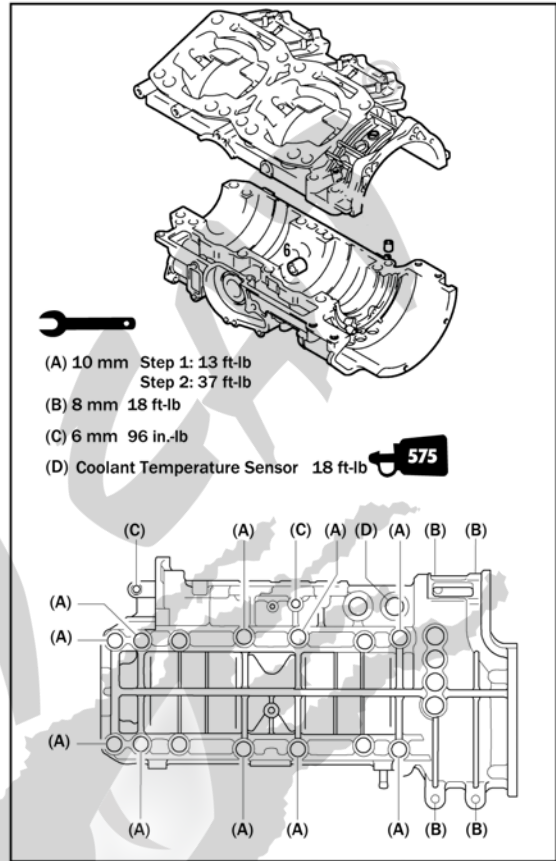
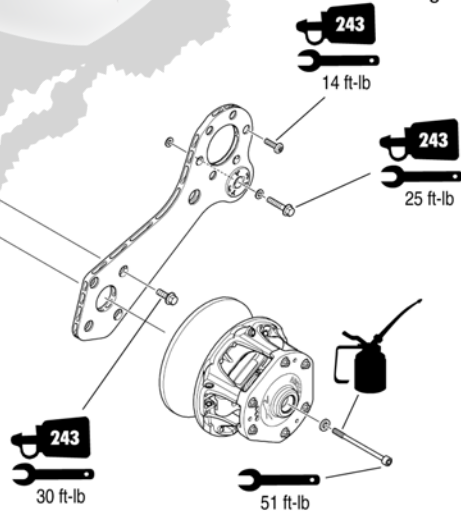
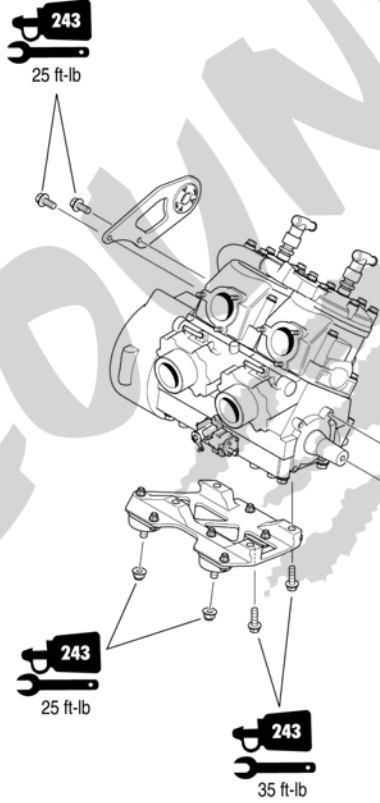
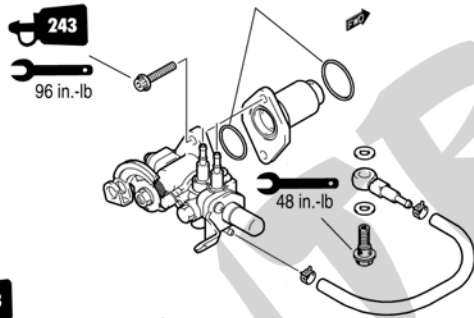
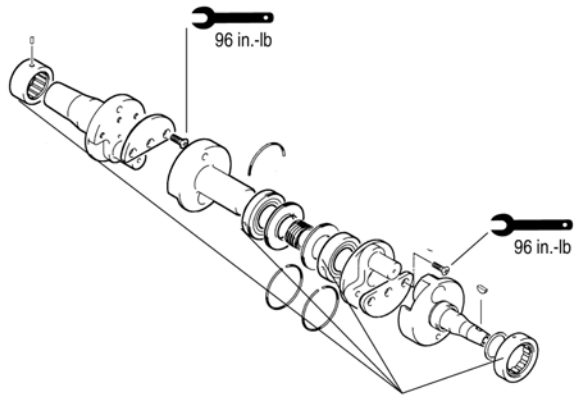

Engine Removing/ Installing - 6000

This engine sub-section has been organized to show a progression for the removing/installing of the Arctic Cat 6000 engine. For consistency purposes, this sub-section shows a complete and thorough progression; however, for efficiency it may be preferable to remove only those components needing to be addressed. Also, some components may vary from model to model. The technician should use discretion and sound judgment.

SPECIAL TOOLS

A number of special tools must be available to the technician when performing service procedures in this engine section.

Description	p/n
Drive Clutch Bolt Tool	0644-281
Drive Clutch Puller	0744-062
Drive Clutch Spanner Wrench	0644-136
Hood Harness Extension	1686-659

■NOTE: Special tools are available from the Arctic Cat Service Parts Department.

CAUTION

Never attempt to substitute any other drive clutch puller for the recommended puller or severe clutch or crankshaft damage will occur.

Removing

■NOTE: For assembling purposes, note cable tie locations securing the harness and cables to the chassis.

■NOTE: Prior to removing the engine, disconnect the hood harness and remove the side access panels; then remove the screws securing the hood to the chassis.

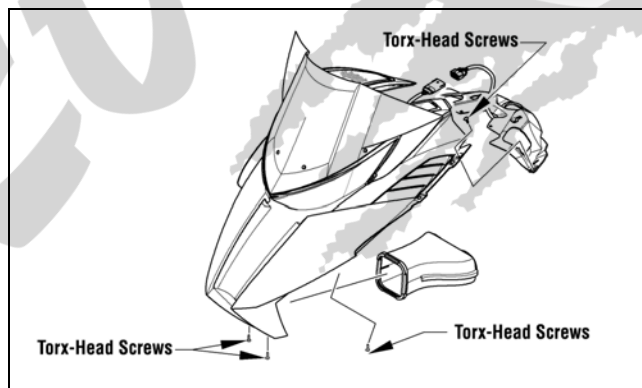

0746-793A

- Carefully remove the exhaust temperature sensor from the expansion chamber.
- Remove all springs securing the expansion chamber and resonator; then remove the expansion chamber and resonator.

- Remove the torx screw from the driven clutch and slide the driven clutch (along with the drive belt) off the driven shaft. Account for alignment washers.
- Using Drive Clutch Bolt Tool, remove the torx-head screw and high-collar washer securing the drive clutch to the crankshaft.
- Using Drive Clutch Puller and Drive Clutch Spanner Wrench, tighten the puller. Remove the drive clutch.

■NOTE: If the drive clutch will not release, sharply strike the head of the puller. Repeat this step until the clutch releases.

- Remove the two screws (A) securing the heat shield to the chassis; then remove the heat shield from the two front locating pins (B) and remove the heat shield.

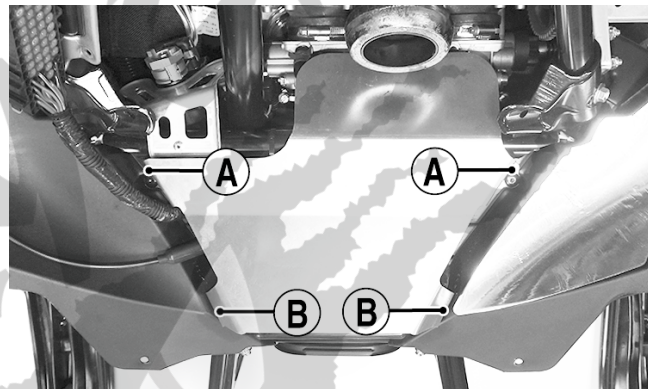

EL-001A

- Disconnect the ECM; then remove the screws securing the right- and left-side fascia panels to the chassis. Remove the panels and ECM as an assembly.

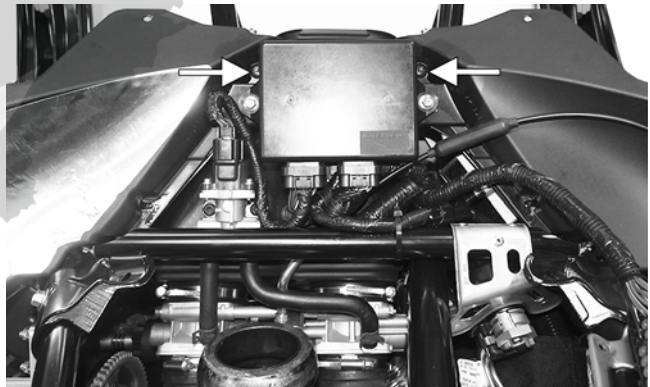

EL-002A

- Remove the cap screws securing the PTO-side front spar to the steering support and shock mount bracket; then remove the spar.

■NOTE: Take care to not drop the spar inserts and nuts when removing the spar.

- Using a small needle-nose pliers, remove the servomotor cable holder; then pull the cable housings down and out of the servomotor.



EL-004A

10. Slide each cable end out of the slot of the clutch; then disconnect the harness from the servomotor.
11. Remove the cap screws and lock nuts securing the shock mount bracket support to the shock mount brackets; then remove the shock mount bracket support.

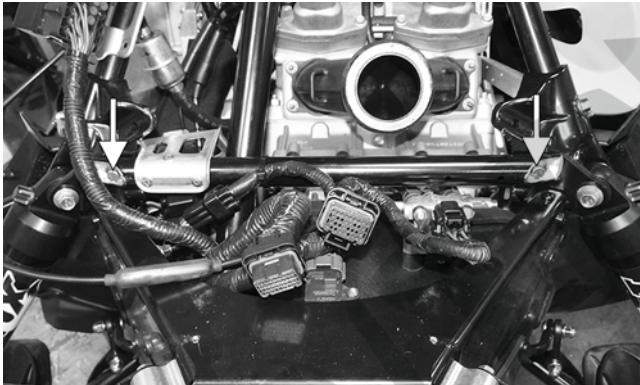

EL-003A

12. Remove idle speed control (ISC) hoses (A) from the top of the throttle bodies; then disconnect the ISC from the main harness (B). Remove the screws (C) securing the ISC; then remove the ISC.

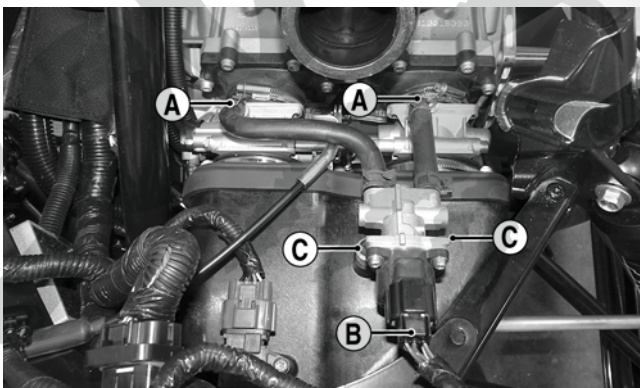

EL-006A

13. Loosen the four clamps securing the throttle body; then lift up the throttle body and disconnect the coolant hoses. Set the throttle body up and out of the way.
14. Remove the intake boot from the chassis.
15. Remove all three oil hoses from the front of the engine.

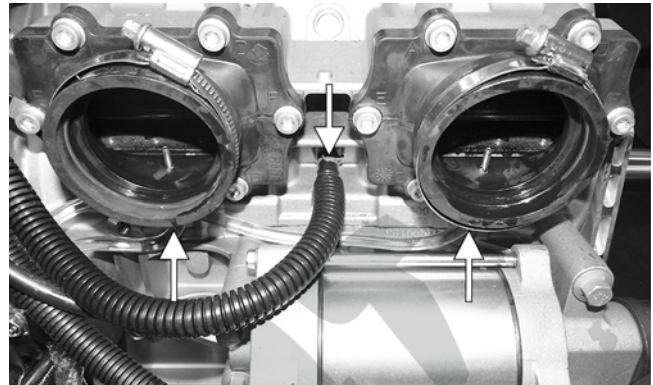

EL-005A

16. Loosen the clamp securing the gasoline hose to the throttle body and remove the hose; then close-off the hose and secure the hose up and out of the way.

⚠ WARNING

The hose may be under pressure; remove it slowly to release the pressure. Place an absorbent towel around the connection to absorb gas.

17. Remove the main harness wrap and disconnect the six harness connectors. Secure the harness up and out of the way.
18. Remove the recoil starter from the engine. Secure it out of the way.
19. Remove the cap screws securing the MAG-side engine mount to the engine.
20. Remove the spark plug caps from the spark plugs; then disconnect the knock sensor and coolant temperature sensor connectors. Remove the cylinder head vent hose.

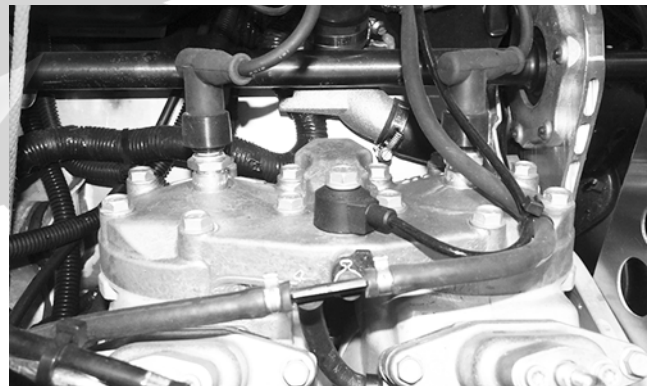

CWI-092

21. Disconnect the lower coolant hose from the front heat exchanger; then remove the coolant hose from the heat exchanger at the rear of the engine.

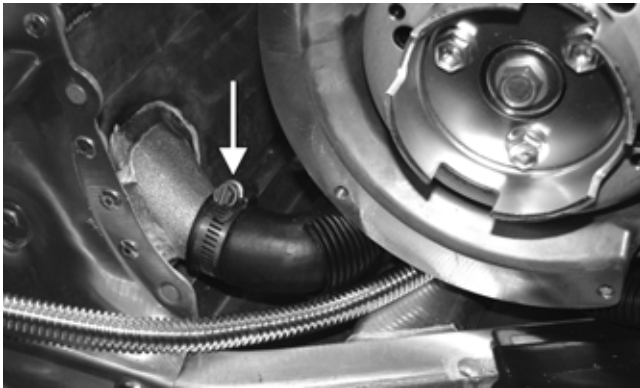

PC141A

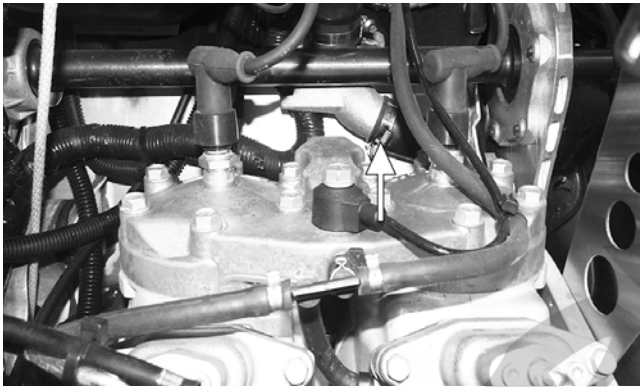

PC178A

22. Remove the four screws securing the PTO-side engine mounting plate to the engine.

■NOTE: Before removing the cap screws, apply a sufficient amount of heat to the cap screws to soften the Loctite.

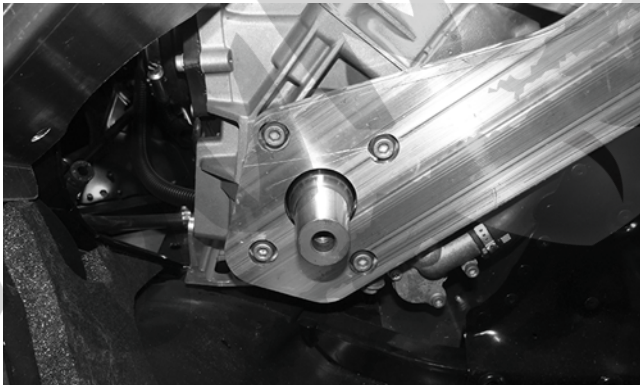

CWI-093

23. Remove the cap screw and two lock nuts securing the engine support plate to the chassis; then lift the engine out of the engine compartment.

■NOTE: If replacing the engine, make sure to remove the engine support plate, exhaust manifold, and three coolant hoses for installation on the new engine.

Installing

■NOTE: If the engine was replaced, make sure to install the existing engine support plate and the exhaust manifold on the new engine. Tighten the exhaust manifold nuts to 12 ft-lb, the M6 engine support plate cap screws to 25 ft-lb, and the M8 engine cap screws to 35 ft-lb. Install the three coolant hoses.

■NOTE: On electric start models, install the starter motor to the engine.

■NOTE: If the engine is brand new, tip the crankcase assembly up on the water pump side; then pour Arctic Cat C-Tec2 engine oil into the center cavity of the crankshaft until the oil is level with the shoulder of the shaft (A).

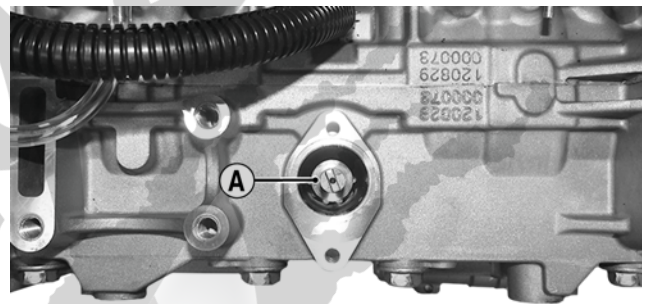

CWI-085A

CAUTION

Failure to fill the center cavity of the crankcase assembly will result in center gear damage and engine failure.

1. Carefully lower the engine into the engine compartment.
2. Install the coolant hose to the heat exchanger at the rear of the engine; then connect the lower coolant hose to the front heat exchanger.

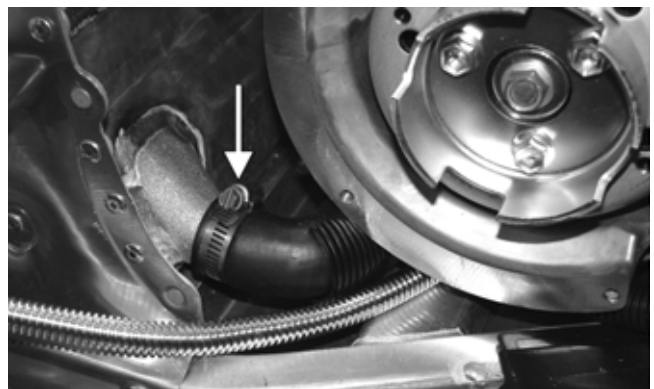

PC141A

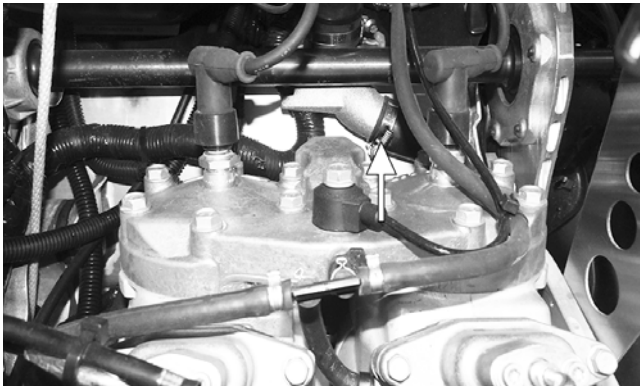

PC178A

3. Install new MAG-side engine mount “patch-lock” cap screws. Finger-tighten only at this time.
4. Install a new “patch-lock” cap screw and new lock nuts to secure the engine support plate to the chassis. Finger-tighten only at this time.
5. Install four new “patch-lock” screws to secure the PTO-side engine mounting plate. Tighten to 30 ft-lb using a crisscross pattern.

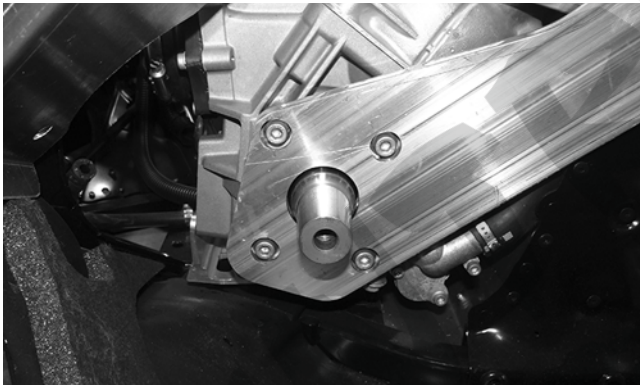

CWI-093

6. Tighten the cap screw and lock nuts (from step 4) to 25 ft-lb.
7. Install the access panel to the center belly panel and chassis and secure using the torx-head screws. Tighten securely.
8. Tighten the cap screws (from step 3) to 25 ft-lb.
9. Connect the knock sensor and coolant temperature sensor connectors; then install the spark plug caps. Secure the coolant temperature sensor connector with a cable tie.
10. Install the cylinder head vent hose.
11. Place the recoil starter into position and secure with the cap screws. Tighten in a crisscross pattern to 96 in.-lb.
12. Before connecting the wiring harness plug-ins, clean the connectors and apply Dielectric Grease to the seal; then connect all harness connectors making sure all wiring and coolant hoses are routed properly as noted in removing. Install the main harness wrap.

■NOTE: Use cable ties to secure the wiring harnesses as necessary.

13. Connect all three oil hoses from the front of the engine. Secure using the existing clamps.

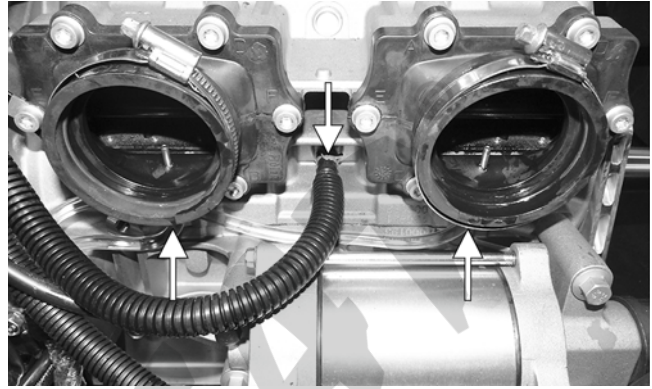

EL-005A

14. Connect the MAG-side throttle body coolant hose; then secure with a clamp.
15. Connect the TPS; then lower the throttle body assembly into the engine compartment.
16. Place the throttle body assembly into position and secure with the flange clamps; then connect the gasoline hose to the throttle body assembly and tighten the clamp securely.

CAUTION

When installing the throttle bodies, make sure the gasoline hose is properly routed to avoid premature wear and/or contact with exhaust components.

17. Connect the PTO-side throttle body coolant hose; then secure with a clamp.
18. Fill the cooling system (see Liquid Cooling System in the Engine-Related Items section).
19. Using the existing clamps, secure the intake flanges to the throttle bodies.
20. With the air intake boot properly positioned on the throttle bodies, secure with the existing clamps.
21. Install the shock mount bracket support; then using new lock nuts, secure the support to the shock mount brackets and tighten to 20 ft-lb.



EL-003A

22. Insert the servomotor cable ends into the slot in the clutch; then connect the servomotor connector. Secure the cables with the holder.

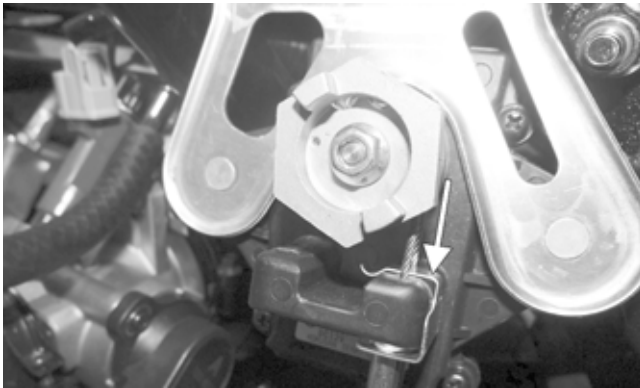

PC187A

23. Rotate the servomotor clockwise to remove any slack from the cables; then install the servomotor retaining clip. Check APV cable adjustment (see Arctic Power Valve (APV) System in the Engine-Related Items section).
24. Install the PTO-side front spar and secure to the steering post and shock mount bracket using the existing cap screws. Tighten the cap screws to 25 ft-lb.
25. Secure the idle speed control (ISC) hoses (A) to the top of the throttle bodies using the existing clamps; then connect the ISC to the main harness (B). Secure the ISC to the intake boot using the existing screws (C). Tighten securely.

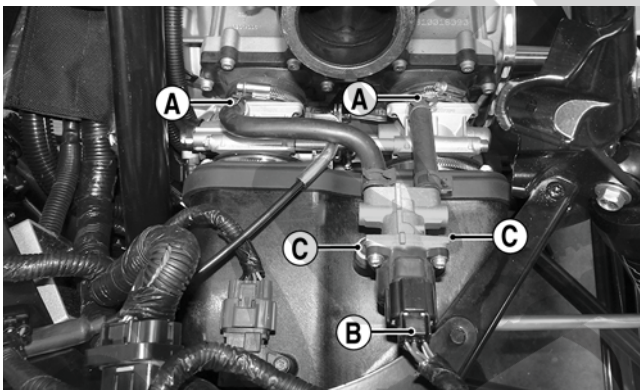

EL-006A

26. Install the fascia panels (with ECM) and secure to the chassis using the existing screws. Tighten securely. Connect the ECM.

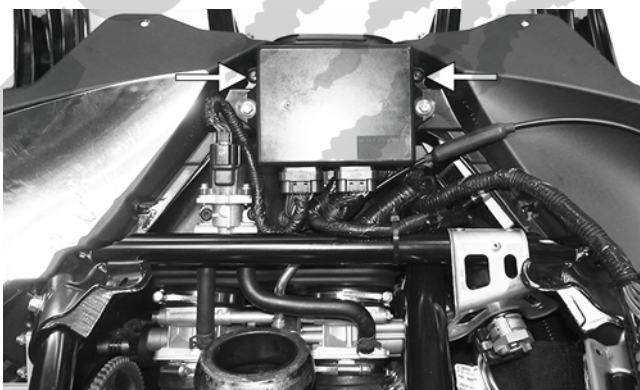

EL-002A

■NOTE: At this point, secure the PDM harness to the shock mount bracket supporting using a cable tie.

27. Position the heat shield onto the two front locating pins (B); then secure it to the chassis with the two screws (A). Tighten securely.

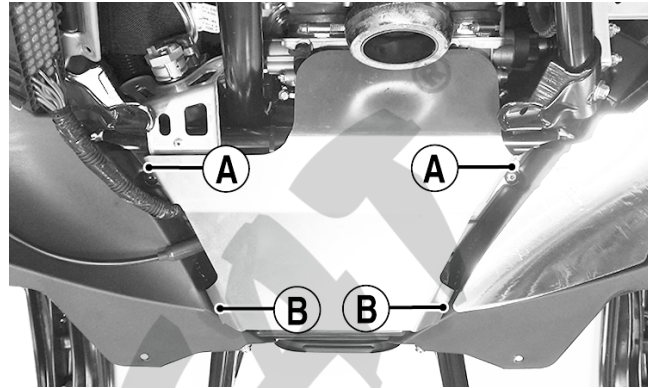

EL-001A

28. Install the resonator and secure with the springs; then place the expansion chamber and gaskets into position and secure to the exhaust manifold and resonator with the springs.

■NOTE: When installing the manifold springs, the long hook portion of the spring must be attached to the exhaust manifold or premature spring failure will result.

29. Install the exhaust temperature sensor into the expansion chamber. Tighten to 34 ft-lb.
30. Place the drive clutch with drive belt into position on the crankshaft and secure with the cap screw (threads coated with oil) and high-collar washer. Tighten to 51 ft-lb.

CAUTION

When installing the drive clutch, do not tighten the clutch cap screw with any kind of impact tool. Tighten cap screw using a hand torque wrench only. Failure to do so could result in stationary sheave damage.

■NOTE: Before installing the drive clutch, be sure to wipe both the crankshaft and clutch mounting tapers clean using a clean towel.

31. Install the driven clutch on the driven shaft; then install the drive belt (see the Drive Train/Track/Brake Systems section).
32. Check drive belt deflection (see the Drive Train/Track/Brake Systems section).
33. Place the hood into position on the front end and secure with the screws; then install the hood harness. Install the side access panels.

CAUTION

Never run the engine with the hood harness disconnected or damage to the electrical system will result.

34. Start the engine and warm up to operating temperature; then verify that all components are functioning properly and that coolant is circulating through the cooling system properly.

35. After running the engine to the proper operating temperature, shut the engine off; then open the access panels and inspect for any signs of coolant, gasoline, or oil leakage.

36. Allow the engine to cool; then check the coolant level and add coolant as necessary. Verify the tightening torque of the drive clutch.

CAUTION

If the engine had a major overhaul or if any major component was replaced, proper engine break-in procedures must be followed (see the General Information section) or severe engine damage may result.



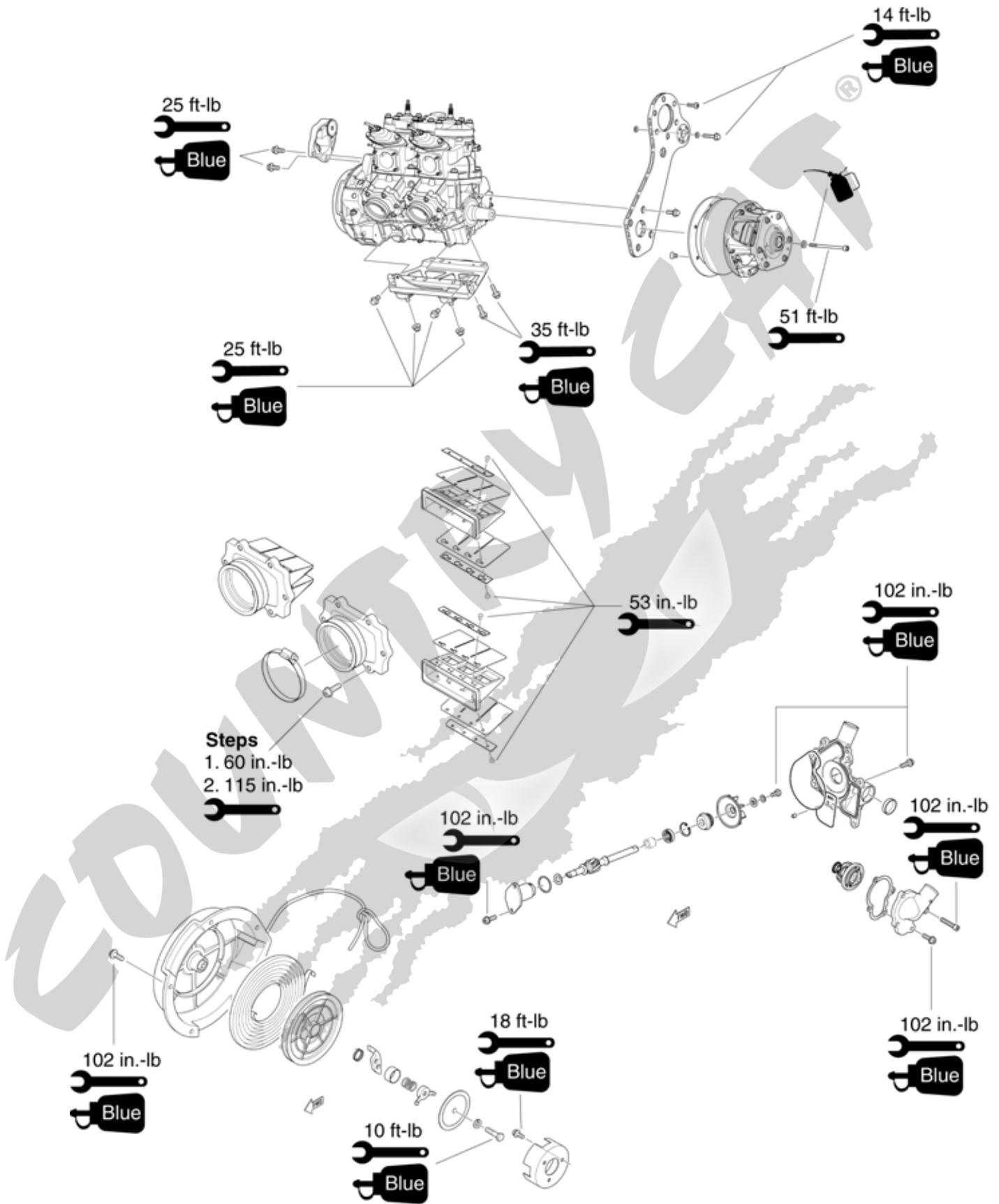

Engine Removing/ Installing - 8000

This engine sub-section has been organized to show a progression for the removing/installing of the Arctic Cat 8000 (ZR/M/XF) engine. For consistency purposes, this sub-section shows a complete and thorough progression; however, for efficiency it may be preferable to remove only those components needing to be addressed. Also, some components may vary from model to model. The technician should use discretion and sound judgment.

SPECIAL TOOLS

A number of special tools must be available to the technician when performing service procedures in this engine section.

Description	p/n
Drive Clutch Bolt Tool	0644-281
Drive Clutch Puller	0744-062
Drive Clutch Spanner Wrench	0644-136
Hood Harness Extension	1686-660

■NOTE: Special tools are available from the Arctic Cat Service Parts Department.

CAUTION

Never attempt to substitute any other drive clutch puller for the recommended puller or severe clutch or crankshaft damage will occur.

Removing

■NOTE: For assembling purposes, note cable tie locations securing the harness and cables to the chassis.

■NOTE: Prior to removing the engine, disconnect the hood harness and remove the side access panels; then remove the screws securing the hood to the chassis.

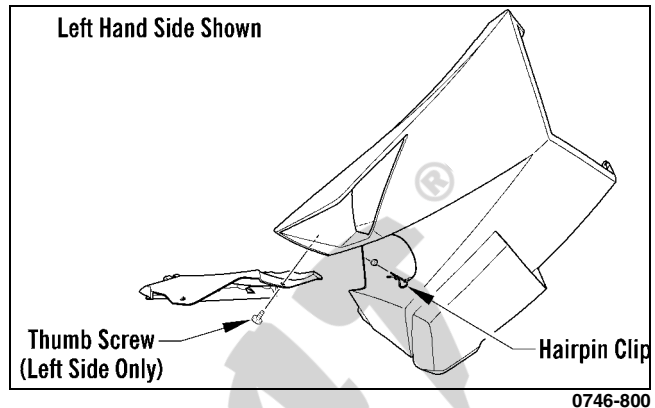
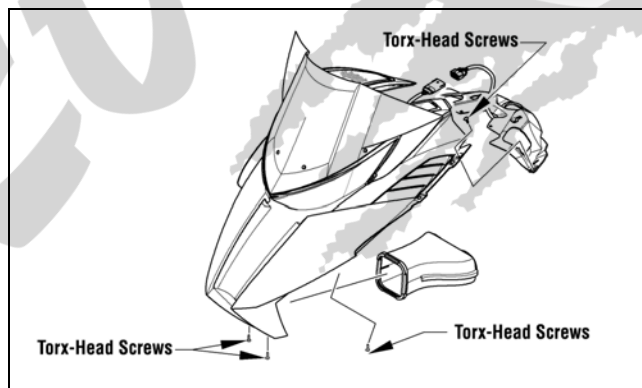

1. Remove the rear belt guard; then remove the exhaust temperature sensor from the expansion chamber.
2. Remove all springs securing the expansion chamber and resonator; then remove the expansion chamber and resonator.
3. Remove the cap screw from the driven clutch and slide the driven clutch (along with the drive belt) off the driven shaft. Account for alignment washers.
4. Using Drive Clutch Bolt Tool, remove the torx-head screw and high-collar washer securing the drive clutch to the crankshaft.
5. Using Drive Clutch Puller and Drive Clutch Spanner Wrench, tighten the puller. Remove the drive clutch.

■NOTE: If the drive clutch will not release, sharply strike the head of the puller. Repeat this step until the clutch releases.

6. Remove the two screws (A) securing the heat shield to the chassis; then remove the heat shield from the two front locating pins (B) and remove the heat shield.

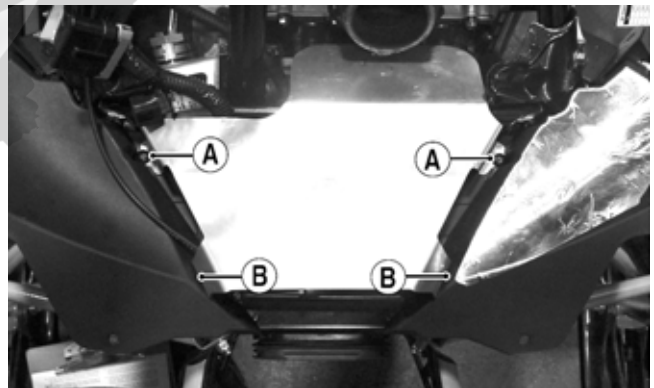

7. Disconnect the ECM; then remove the screws securing the right and left-side fascia panels to the chassis. Remove the panels and ECM as an assembly.



PC188A

8. Remove the caps screws securing the PTO-side front spar to the steering support and shock mount bracket; then remove the spar.

■ **NOTE:** Take care to not drop the spar inserts and nuts when removing the spar.

9. Using a small needle-nose pliers, remove the servomotor cable holder; then pull the cable housings down and out of the servomotor.

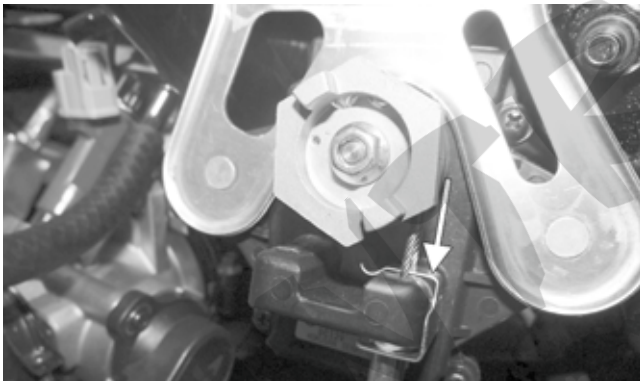

PC187A



PC134

10. Slide each cable end out of the slot of the clutch; then disconnect the connector from the servomotor.
11. Remove the lock nuts securing the shock mount bracket support to the shock mount brackets; then remove the shock mount bracket support.



PC186A

12. Drain the engine coolant (see Liquid Cooling System - the Engine-Related Items section).

13. Loosen the clamp securing the gasoline hose to the throttle body and remove the hose; then close-off the hose and secure the hose up and out of the way.



PC135A

⚠ WARNING

The hose may be under pressure; remove it slowly to release the pressure. Place an absorbent towel around the connection to absorb gas.

14. Loosen the clamps securing the air intake boot to the throttle bodies and pull the air intake boot forward enough to gain access to the throttle body assembly. Remove and retain the clamps.

15. Loosen the flange clamps securing the throttle body assembly to the intake flanges and disconnect the oil-injection control rod from the throttle body; then loosen the clamps securing the throttle body coolant hoses. Disconnect the TPS and move the throttle body assembly forward and out of the way.

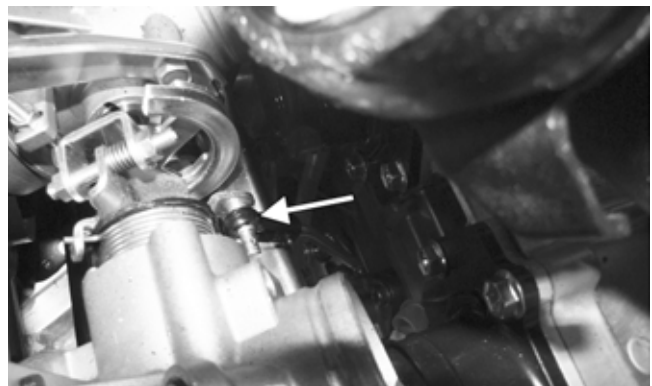

PC138A

16. Remove the main harness wrap and disconnect the six harness connectors. Secure the harness up and out of the way.
17. Close-off the oil hose with a clamping device; then remove the hose clamp and oil hose from the oil pump.

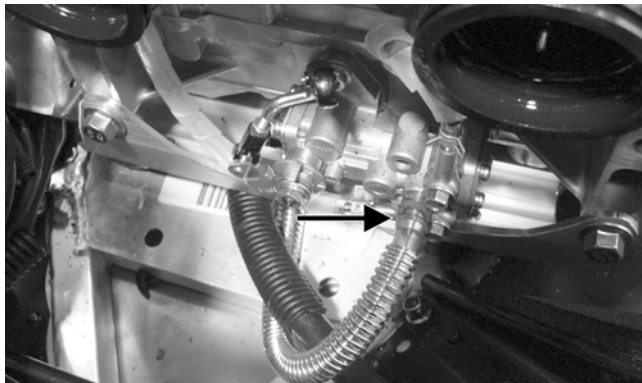

PC139A

18. Remove the recoil starter from the engine. Secure it out of the way.
19. Remove the cap screws securing the MAG-side engine mount to the engine. Discard the cap screws.
20. Remove the spark plug caps from the spark plugs; then disconnect the knock sensor and coolant temperature sensor connectors. Remove the cylinder head vent hose.

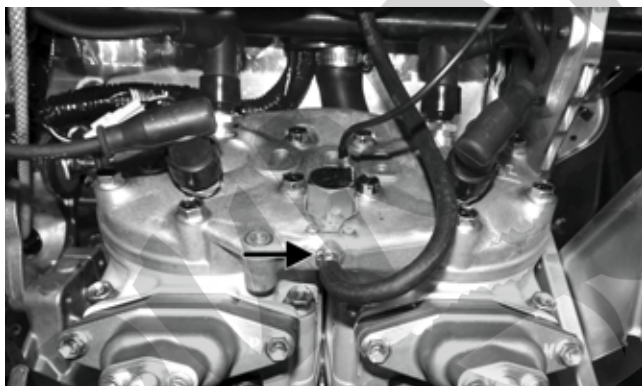

PC178B

21. Disconnect the lower coolant hose from the front heat exchanger; then remove the coolant hose from the heat exchanger at the rear of the engine.

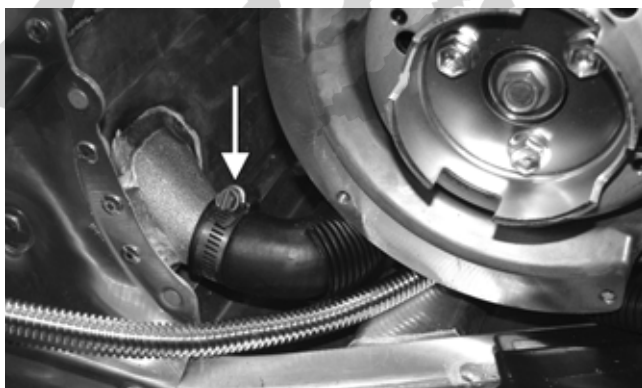

PC141A

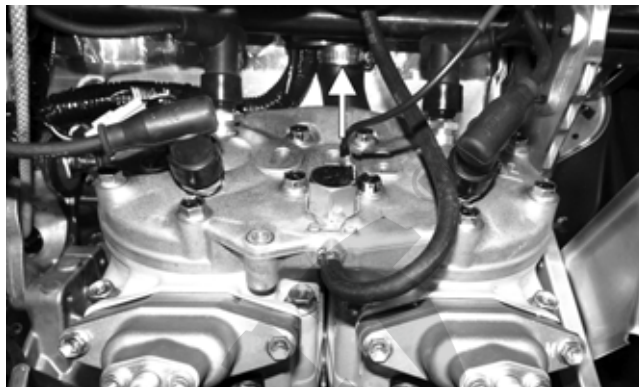

PC178A

22. Remove and discard the eleven screws securing the PTO-side engine mounting plate. Account for the spring washer between the rear mount and the tunnel.

■ **NOTE:** Before removing the cap screws, apply a sufficient amount of heat to the cap screws to soften the Loctite.

23. Remove the torx-head screw securing the front belt guard to the skid plate; then remove the three cap screws and carriage bolt nut securing the PTO-side chassis support to the shock mount bracket and chassis. Remove the chassis support and account for the carriage bolt.
24. Remove the torx-head screws securing the access panel to the center belly pan and chassis.
25. Remove the cap screw and two lock nuts securing the engine support plate to the chassis; then lift the engine out of the engine compartment.

■ **NOTE:** If replacing the engine, make sure to remove the engine support plate, exhaust manifold, three coolant hoses, and oil injection control rod for installation on the new engine.

Installing

■ **NOTE:** If the engine was replaced, make sure to install the existing engine support plate, exhaust manifold, three coolant hoses, and oil injection control rod on the new engine. Tighten the exhaust manifold nuts to 17 ft-lb and the six engine support plate cap screws to 25 ft-lb.

1. Carefully lower the engine into the engine compartment.
2. Install the coolant hose to the heat exchanger at the rear of the engine; then connect the lower coolant hose to the front heat exchanger.
3. Install new MAG-side engine mount “patch-lock” cap screws. Finger-tighten only at this time.
4. Install a new “patch-lock” cap screw and new lock nuts securing the engine support plate to the chassis. Finger-tighten only at this time.

5. Install the PTO-side chassis support to the shock mount bracket and chassis. Secure with the cap screws and carriage bolt nut. Tighten the rear chassis cap screw to 25 ft-lb, the carriage bolt nut to 12 ft-lb, and the front shock mount cap screws to 12 ft-lb.
6. Install the torx-head screw to secure the front belt guard to the skid plate. Tighten securely.
7. Install eleven new “patch-lock” screws securing the PTO-side engine mounting plate starting with the four plate-to-engine screws. Finger-tighten only at this time.

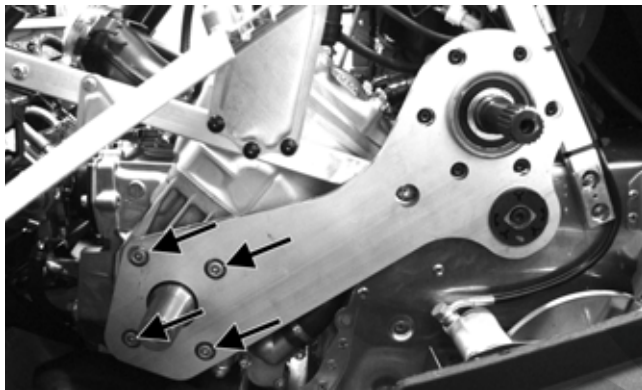

PC180A

■NOTE: Make sure to install the spring washer between the rear mount and the tunnel.

8. From step 7, tighten the four front screws to 30 ft-lb, the six top rear screws to 14 ft-lb, and the lower rear screw to 25 ft-lb using the following sequence.

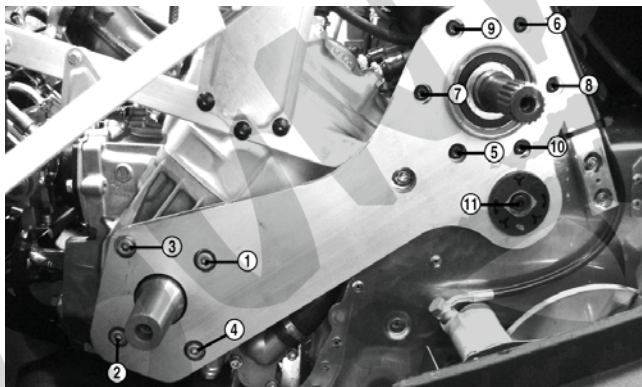

PC180B

9. Tighten the cap screw and lock nuts (from step 4) to 25 ft-lb.
10. Install the access panel to the center belly and chassis and secure using the torx-head screws. Tighten securely.
11. Tighten the cap screws (from step 3) to 25 ft-lb.
12. Connect the knock sensor and coolant temperature sensor connectors; then install the spark plug caps. Secure the coolant temperature sensor connector with a cable tie.
13. Install the cylinder head vent hose.

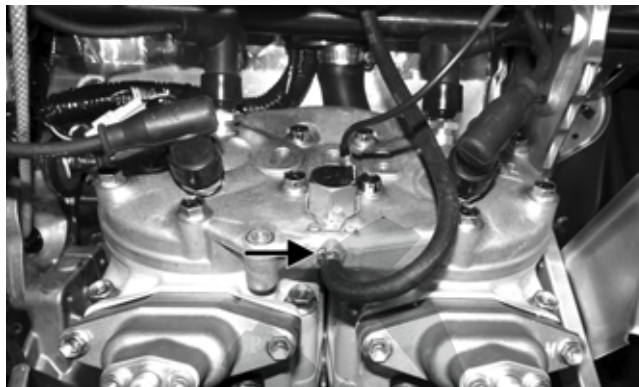

PC178B

14. Place the recoil starter into position and secure with the cap screws. Tighten in a crisscross pattern to 96 in.-lb.
15. Before connecting the wiring harness plug-ins, clean the connectors and apply Dielectric Grease to the seal; then connect all harness connectors making sure all wiring and coolant hoses are routed properly as noted in removing. Install the main harness wrap.

■NOTE: Use cable ties to secure the wiring harnesses as necessary.

16. Connect the oil hose to the oil pump. Secure with the clamp.

■NOTE: After securing the oil hose to the oil pump, remove the bleed screw to allow any air in the hose/pump to be released.



PC179A

17. Connect the MAG-side throttle body coolant hose; then secure with a clamp.
18. Connect the TPS; then lower the throttle body assembly into the engine compartment.
19. Place the throttle body assembly into position and secure with the flange clamps; then connect the gasoline hose to the throttle body assembly and tighten the clamp securely.

CAUTION

When installing the throttle bodies, make sure the gasoline hose is properly routed to avoid premature wear and/or contact with exhaust components.

20. Connect the PTO-side throttle body coolant hose; then secure with a clamp.

21. Fill the cooling system (see Liquid Cooling System in the Engine-Related Items section).
22. Install the oil injection control rod to the throttle body; then verify oil-injection pump synchronization (see the Fuel Systems section).
23. Using the existing clamps, secure the intake flanges to the throttle bodies.
24. With the air intake boot properly positioned on the throttle bodies, secure with the existing clamps.
25. Install the shock mount bracket support; then using new lock nuts, secure the support to the shock mount brackets and tighten to 20 ft-lb.

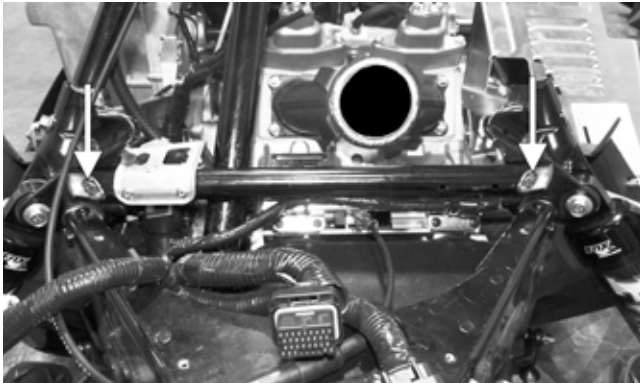

PC186A

26. Insert the servomotor cable ends into the slot in the clutch; then connect the servomotor connector. Secure the cables with the holder.

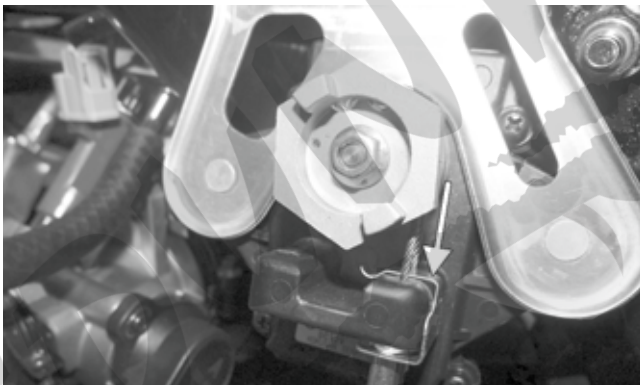

PC187A

27. Rotate the servomotor clockwise to remove any slack from the cables; then install the servomotor retaining clip. Check APV cable adjustment (see Arctic Power Valve (APV) System in the Engine-Related Items section).
28. Install the PTO-side front spar and secure to the steering post and shock mount bracket using the existing cap screws. Tighten the cap screws to 25 ft-lb.
29. Install the fascia panels (with ECM) and secure to the chassis using the existing screws. Tighten securely. Connect the ECM.

■NOTE: At this point, secure the PDM harness to the shock mount bracket support using a cable tie.

30. Position the heat shield onto the two front locating pins (B); then secure it to the chassis with the two screws (A). Tighten securely.

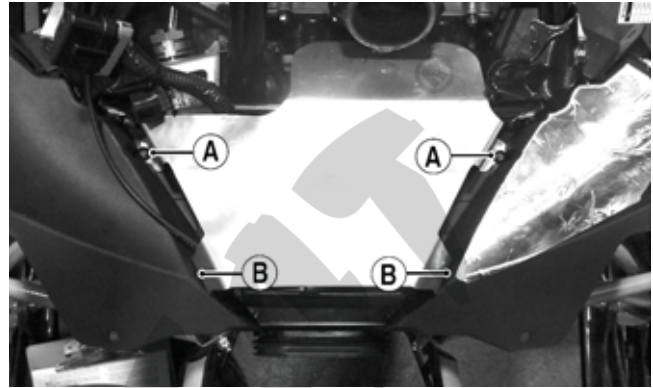

PC189A

31. Install the resonator and secure with the springs; then place the expansion chamber and gaskets into position and secure to the exhaust manifold and resonator with the springs.

■NOTE: When installing the manifold springs, the long hook portion of the spring must be attached to the exhaust manifold or premature spring failure will result.

32. Install the exhaust temperature sensor into the expansion chamber. Tighten to 34 ft-lb.
33. Place the drive clutch with drive belt into position on the crankshaft and secure with the cap screw (threads coated with oil) and high-collar washer. Tighten to 51 ft-lb.

CAUTION

When installing the drive clutch, do not tighten the clutch cap screw with any kind of impact tool. Tighten cap screw using a hand torque wrench only. Failure to do so could result in stationary sheave damage.

■NOTE: Before installing the drive clutch, be sure to wipe both the crankshaft and clutch mounting tapers clean using a clean towel.

34. Install the driven clutch on the driven shaft; then install the drive belt (see the Drive Train/Track/Brake Systems section).
35. Install the driven clutch (see Driven clutch in the Drive Train/Track/Brake Systems section); then check drive belt deflection (see the Drive Train/Track/Brake Systems section). Install the rear belt guard.
36. Place the hood into position on the front end and secure with the screws; then install the hood harness. Install the side access panels.

CAUTION

Never run the engine with the hood harness disconnected or damage to the electrical system will result.

37. Start the engine and warm up to operating temperature; then verify that all components are functioning properly and that coolant is circulating through the cooling system properly.

38. After running the engine to the proper operating temperature, shut the engine off; then open the access panels and inspect for any signs of coolant, gasoline, or oil leakage.

39. Allow the engine to cool; then check the coolant level and add coolant as necessary. Verify the tightening torque of the drive clutch.

CAUTION

If the engine had a major overhaul or if any major component was replaced, proper engine break-in procedures must be followed (see the General Information section) or severe engine damage may result.



Assembly Schematic - 8000

Torque Specification Tolerances	
Torque (ft-lb)	Tolerance
0-15	±20%
16-39	±15%
40+	±10%

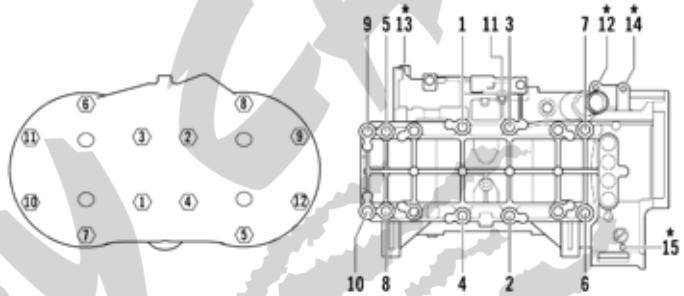
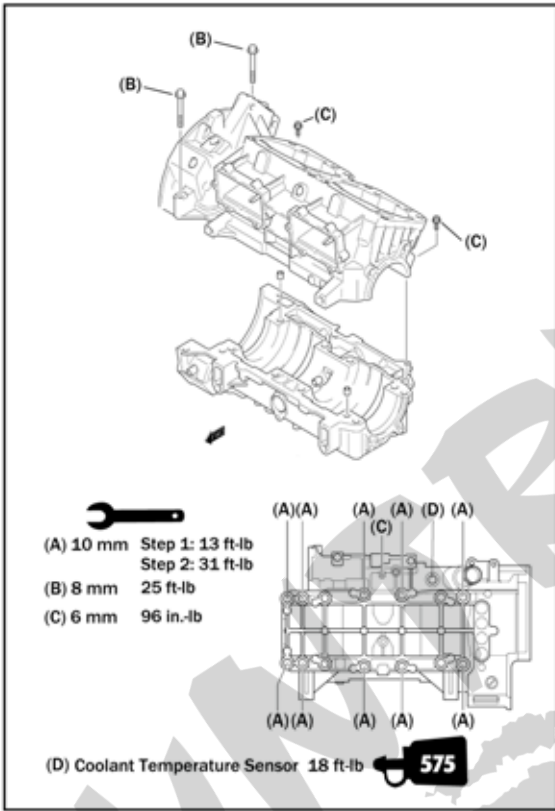

* Accessible from Top Side

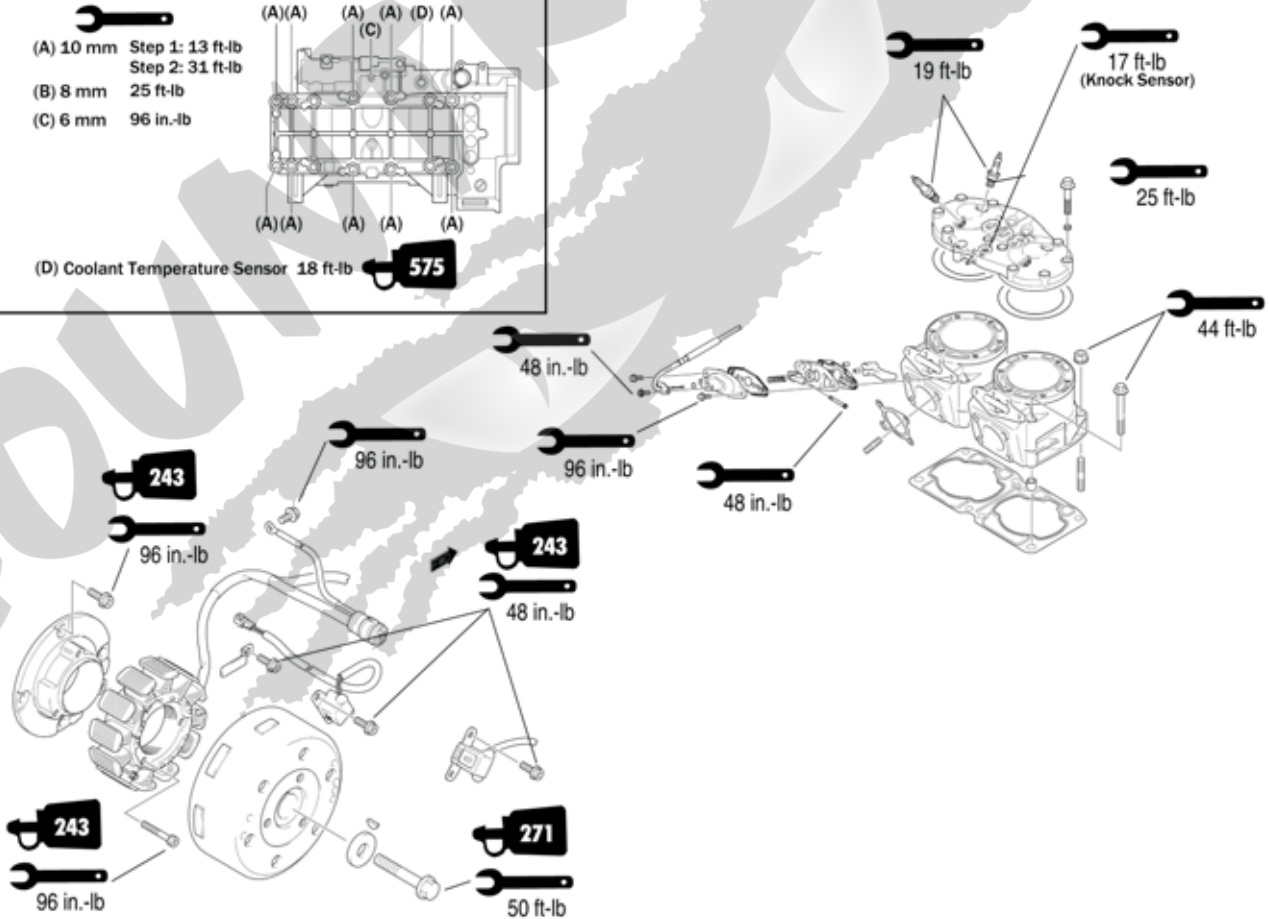

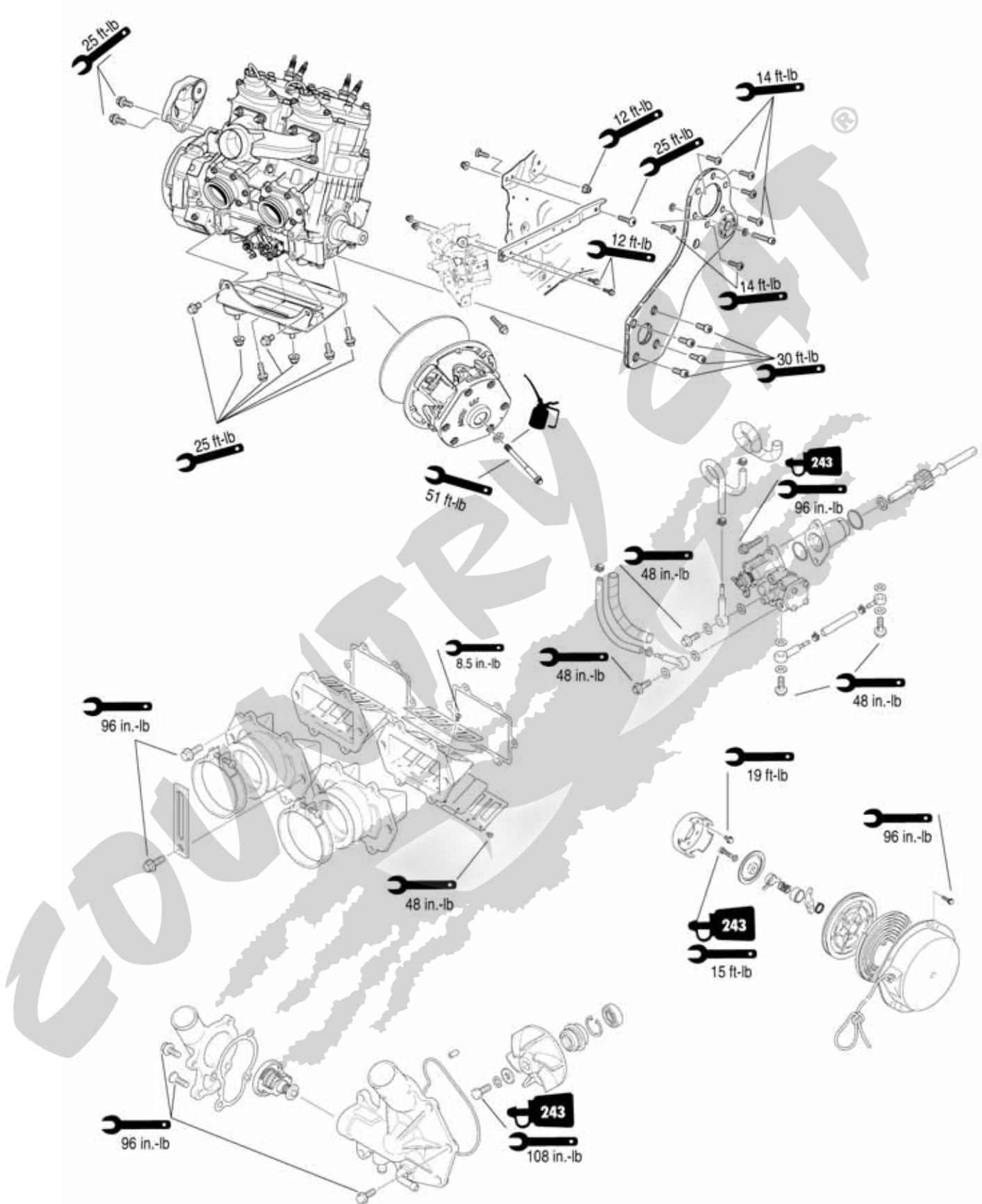

800_12_2

Engine Servicing - 4000

This engine sub-section has been organized to show a progression for servicing of the Arctic Cat 4000 engine. For consistency purposes, this sub-section shows a complete and thorough progression; however, for efficiency it may be preferable to disassemble only those components needing to be addressed. Also, some components may vary from model to model. The technician should use discretion and sound judgment.

■NOTE: Some illustrations and photographs used in this section are used for clarity purposes only and are not designed to depict actual conditions.

■NOTE: Whenever a part is worn excessively, cracked, or damaged in any way, replacement is necessary.

SPECIAL TOOLS

A number of special tools must be available to the technician when performing service procedures in this engine section.

Description	p/n
Ball Hone	0644-292
Flywheel Spanner Wrench	0144-007
Flywheel Puller	0744-040
Flywheel Puller Insert	0644-179
Oil Seal Protector Tool	0644-219
Piston Pin Puller	0644-328
Surface Plate	0644-016
Water Pump Bearing and Seal Tool Kit	0644-557
Vacuum Test Pump	0644-131
V Blocks	0644-535

■NOTE: Special tools are available from the Arctic Cat Service Parts Department.

Disassembling

1. Remove the exhaust manifold from the engine. Account for flange nuts and gaskets; then remove the clamp securing the coolant supply hose from the cylinder head to the water pump. Remove the hose from the engine.
2. Using the Flywheel Spanner Wrench to secure the flywheel, remove the flywheel cap screw and flat washer; then remove the three starter pulley cap screws and remove the pulley.

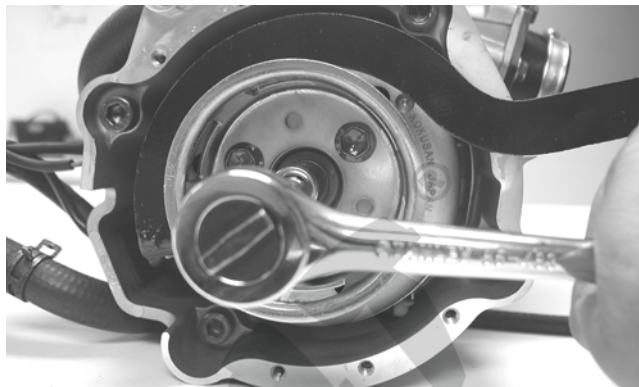

FC014

3. Install Flywheel Puller Insert onto the end of the crankshaft; then using Flywheel Puller, remove the flywheel from the crankshaft by tightening the puller bolt, striking the head of the puller bolt with a hammer, and tightening again. Repeat this procedure until the flywheel is free. Account for the key.

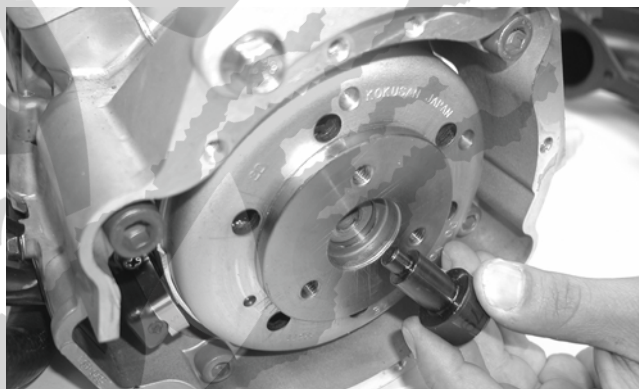

FC016

CAUTION

To prevent damage to the crankshaft, do not thread puller bolts more than 1/2 in. into the flywheel. Damage to the coils may result.



CM013

■NOTE: To ensure the cleanliness of the flywheel magnets, place the flywheel (with the magnets facing upward) on a clean bench.

4. Remove the ignition timing sensor and clamp.

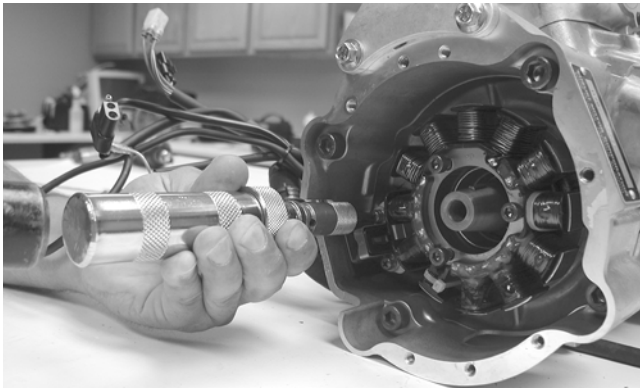

FC022

- Remove the Allen-head cap screws securing the stator to the stator plate. Move the stator to the side to access the Phillips-head cap screw securing the stator lead wire; then remove the cap screw.

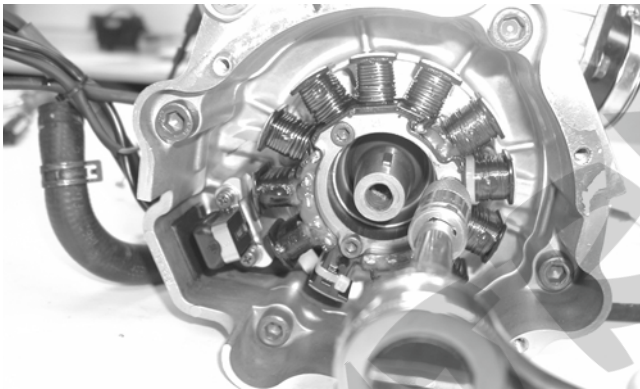

FC018

- Remove the stator plate from the engine.

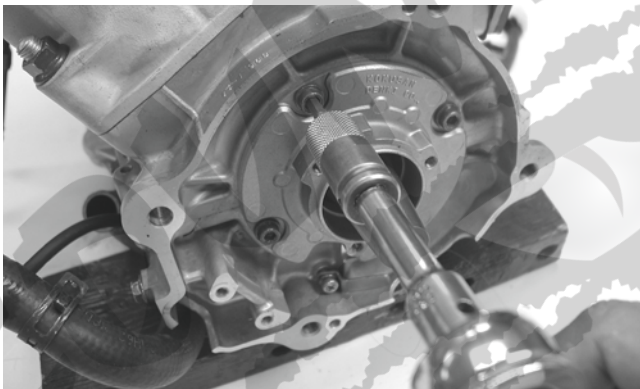

FC021

■NOTE: The stator plate screws had Loctite applied to the threads during assembly. Using an impact driver, apply a sharp blow to the head of each screw to break the Loctite loose before removal.

- Remove the spark plugs.
- Remove the cap screws with O-rings securing the cylinder head; then separate from the cylinders. Account for the O-rings.
- Remove the oil-injection hose from each flange and the crankcase nozzle.

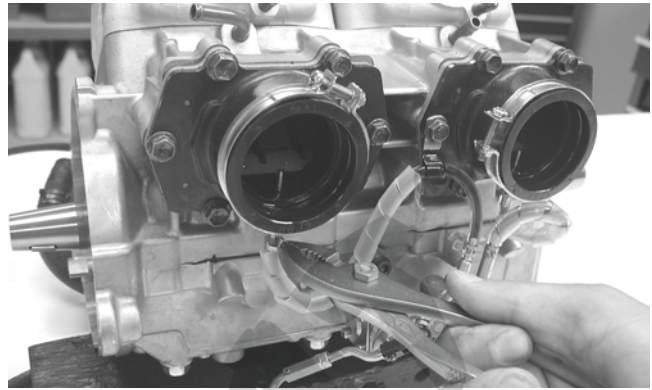

FC026

■NOTE: When removing the cylinders, place the engine on its intake flanges on a drain tray to allow residual coolant to drain from the cylinder/crankcase water jacket.

- Remove the eight nuts securing the cylinders to the crankcase; then using a rubber hammer, gently tap the cylinders and remove from the crankcase by lifting them straight up off their studs. Account for gasket(s) and any alignment pins.

- Remove the PTO-side piston-pin circlip from the PTO-side piston; then remove the MAG-side piston-pin circlip from the MAG-side piston. Discard the circlips.



CM149

- Using Piston Pin Puller, remove the piston pins from both pistons.

■NOTE: For proper assembly, keep all MAG-side components and all PTO-side components separated. Assemble them on their proper sides.

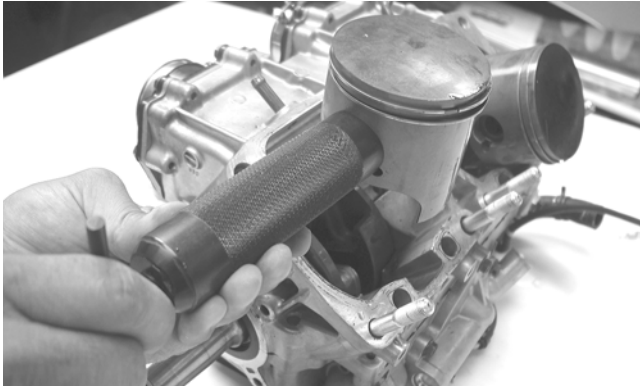

FC029

CAUTION

DO NOT use any type of punch to drive the piston pin free of the piston; damage may result. Use a piston pin puller only.

- Lift the pistons clear of the connecting rods and remove the small-end connecting-rod bearings (account for two washers); then remove the piston rings. Keep each piston with its rings; keep each piston pin and bearing together as a set.

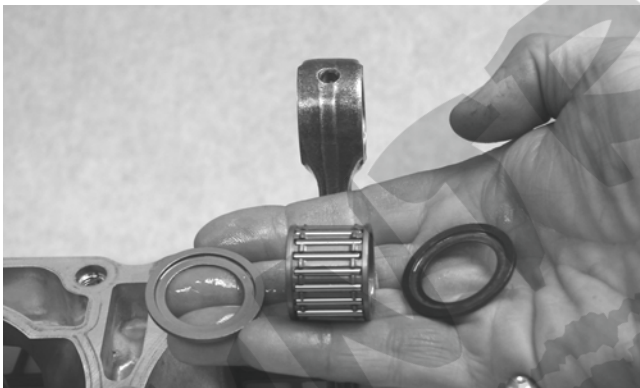

CM151

CAUTION

Place rubber bands over the connecting rods and around the cylinder studs to prevent the connecting rods from damaging the crankcase.

- Remove the intake flanges and reed valve assemblies.

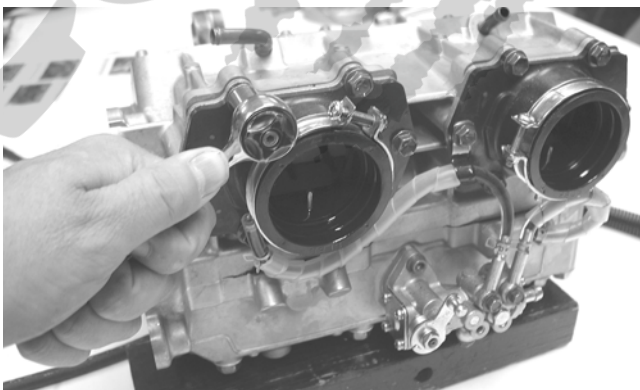

FC030

- Remove the three cap screws securing the thermostat cap; then remove the cap, gasket, and thermostat.

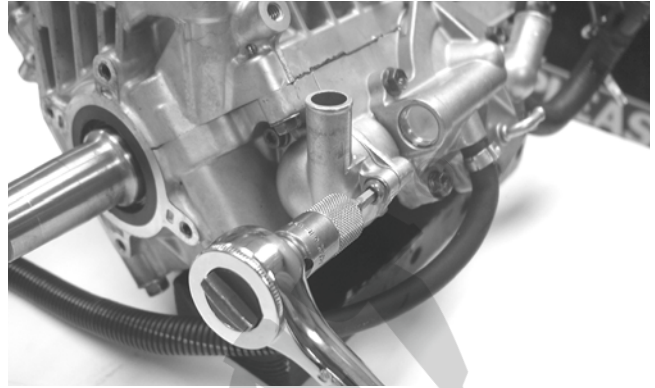

FC032

- Remove the six screws securing the water pump cover to the crankcase and remove the cover. Account for the O-ring gasket and the alignment pins.

- Remove the cap screw securing the water pump impeller; then slide the impeller free of the shaft.

- Remove either lower union cap screw securing the lower check valve assembly; then remove the two screws securing the oil-injection pump to the crankcase. Remove the pump, retainer, and O-ring.

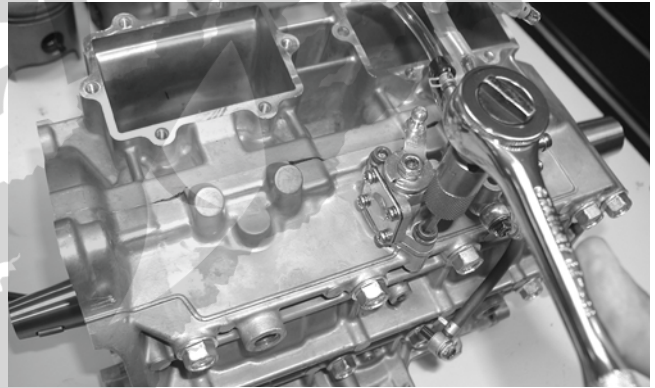

FC031

- Turn the engine upside down on support blocks and remove the coolant temperature sensor (if necessary).

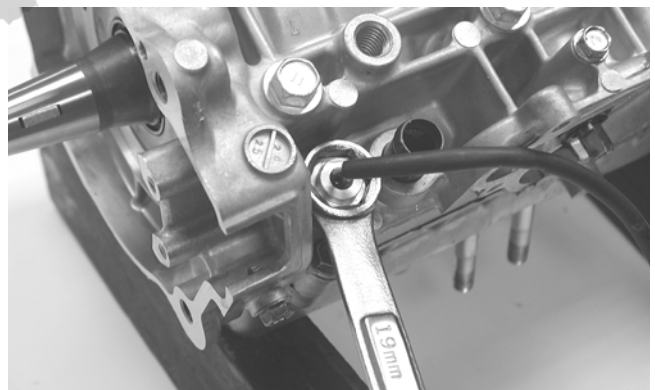

FC033

- With its bottom side up on two support blocks, remove the cap screws securing the crankcase halves.

21. Separate the crankcase halves by installing two crankcase cap screws in opposite corners leaving the heads approximately 1/4 in. out. Using a plastic hammer and lifting on the ends of the crankshaft, tap on each cap screw head until the case halves separate. Remove the cap screws.

CAUTION

DO NOT drive any tool between halves to separate the crankcase. Damage to the sealing surfaces will result.

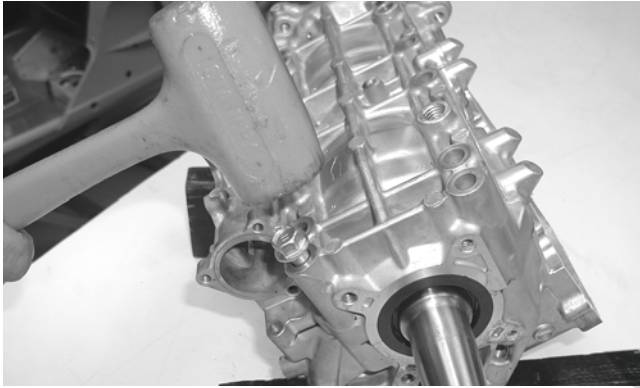

FC034

22. Lift the bottom half of the crankcase off the top half.

CAUTION

Care must be taken to not allow the connecting rods to drop onto the sealing surface of the bottom case half.

23. Lift the crankshaft free from the top half of the crankcase and slide the crankshaft oil seals off the crankshaft. Account for the C-ring. Remove the bearing retaining pins and account for the crankcase dowel pins.

NOTE: The end bearings are not pressed onto the crankshaft. After removing the seals, use care not to allow the bearings to slide off the crankshaft.

24. Remove the oil-injection pump/water pump drive-shaft from the lower crankcase half. Account for the thrust washer on the outer end of the shaft.

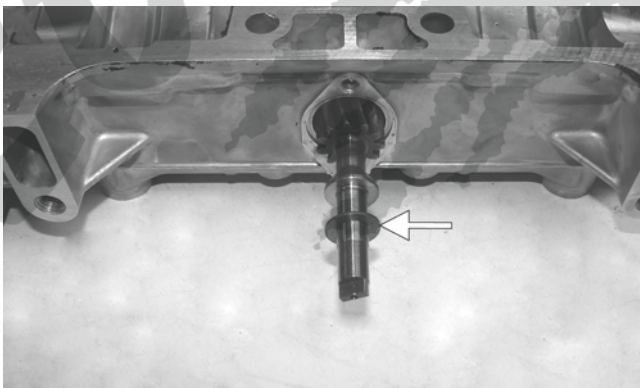

CM159A

NOTE: When replacing the inner water pump seals, use the recommended Water Pump Bearing and Seal Tool Kit only.

25. Place the crankcase on the bench with the water pump side down. Using the long seal driver, drive the mechanical water pump seal from the crankcase.

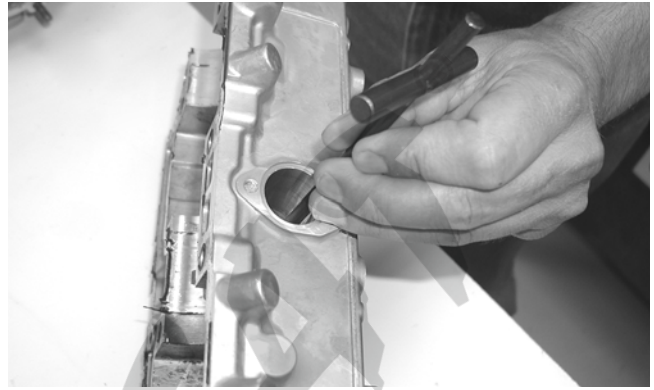

FC036

26. Using a pair of snap ring pliers, remove the snap ring securing the inner seal in the crankcase.
27. Using the hooked end of the tool, pull the inner seal free of the crankcase.
28. Using the hooked end of the tool, pry the seal ring from the backside of the water pump impeller.

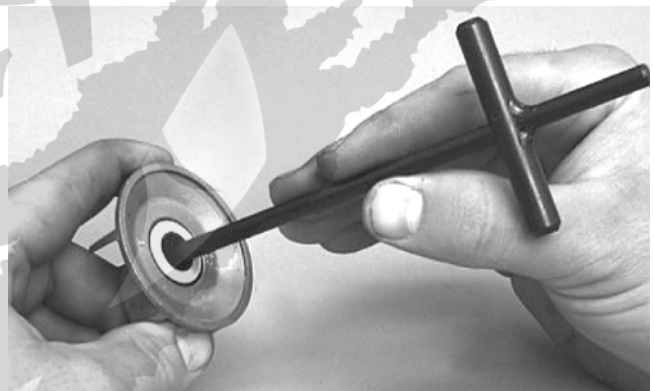

AN327D

Cleaning and Inspecting

CYLINDER HEAD

1. Using a non-metallic carbon removal tool, remove any carbon buildup from the combustion chambers being careful not to nick, scrape, or damage the combustion chambers or the sealing surfaces.
2. Inspect the spark-plug holes for any damaged threads.
3. Inspect the cylinder head for flatness using a straightedge and a feeler gauge. Acceptable warpage must not exceed 0.002 in.

NOTE: If the warpage exceeds specification, resurface the cylinder head using procedures identified in step 4.

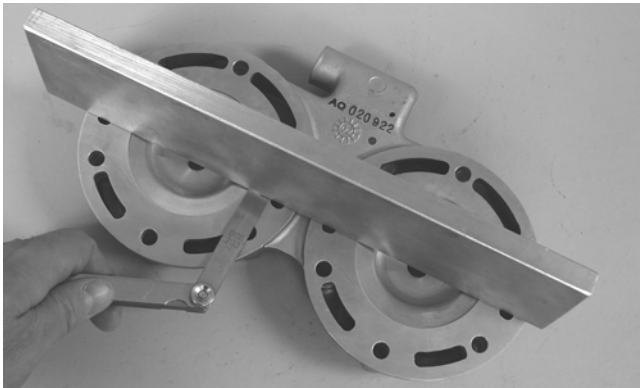

FS270

- Place the cylinder head on a Surface Plate covered with #400 grit wet-or-dry sandpaper. Using light pressure, move each cylinder head in a figure eight motion. Inspect the sealing surface for any indication of high spots. A high spot can be noted by a bright metallic finish. Correct any high spots before assembly by continuing to move the cylinder head in a figure eight motion until a uniform bright metallic finish is attained.

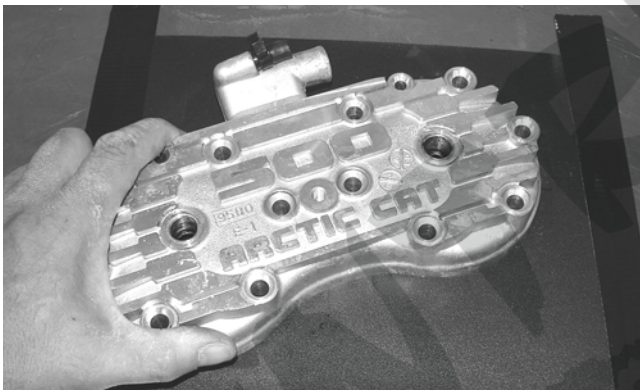

CM018

CAUTION

Water or parts-cleaning solvent must be used in conjunction with the wet-or-dry sandpaper or damage to the sealing surface may result.

CYLINDERS

- Using a non-metallic carbon removal tool, remove carbon buildup from the exhaust ports.
- Wash the cylinders in parts-cleaning solvent.
- Inspect the cylinders for pitting, scoring, scuffing, and corrosion. If marks are found, repair the surface with a Ball Hone and honing oil.

■NOTE: To produce the proper 45° crosshatch pattern, maintain a low drill RPM. If honing oil is not available, use a lightweight, petroleum-based oil. Thoroughly clean the cylinders after honing using detergent soap and hot water and dry with compressed air; then immediately apply oil to the cylinder bores. If a bore is severely damaged or gouged, the cylinder must be replaced.

- Place the head surface of each cylinder on the surface plate covered with #400 grit wet-or-dry sandpaper. Using light pressure, move each cylinder in a figure eight motion. Inspect the surface for any indication of high spots. A high spot can be noted by a bright metallic finish. Correct any high spots before assembly by continuing to move the cylinder in a figure eight motion until a uniform bright metallic finish is attained.

CAUTION

Water or parts-cleaning solvent must be used in conjunction with the wet-or-dry sandpaper or damage to the sealing surface may result.

PISTON ASSEMBLY

- Using a non-metallic carbon removal tool, remove the carbon buildup from the dome of each piston.
- Snap an old piston ring into two pieces; then grind the end of the old ring to a 45° angle and to a sharp edge. Using the sharpened ring as a tool, clean carbon from the ring-grooves. Be sure to position the ring with its tapered side up.

CAUTION

Improper cleaning of the ring-grooves by the use of the wrong type of ring-groove cleaner will result in severe damage to the piston.

- Inspect each piston for cracks in the piston pin and skirt areas.
- Inspect each piston for seizure marks or scuffing. Repair with #400 grit wet-or-dry sandpaper and water or honing oil.



AN135

■NOTE: If scuffing or seizure marks are too deep to correct with the sandpaper, it will be necessary to replace the piston.

- Inspect the perimeter of each piston for signs of excessive “blowby.” Excessive “blowby” indicates worn piston rings or an out-of-round cylinder.

■NOTE: If synthetic oil is being used, a certain amount of “blowby” may be visible under normal use.

CRANKCASE

■NOTE: The coolant temperature sensor must be removed for this procedure.

1. Wash the crankcase halves in parts-cleaning solvent.

■NOTE: Before washing the crankcase halves, make sure the four bearing dowel pins have been removed and accounted for.

2. Inspect the crankcase halves for scoring, pitting, scuffing, or any imperfections in the casting.
3. Inspect all threaded areas for damaged or stripped threads.
4. Inspect the bearing areas for cracks or excessive bearing movement. If evidence of excessive bearing movement is noted, the crankcase must be replaced.
5. Inspect the bearing dowel pins for wear.
6. Inspect the sealing surfaces of the crankcase halves for trueness by placing each crankcase half on the surface plate covered with #400 grit wet-or-dry sandpaper. Using light pressure, move each half in a figure eight motion. Inspect the sealing surfaces for any indication of high spots. A high spot can be noted by a bright metallic finish. Correct any high spots by continuing to move the half in a figure eight motion until a uniform bright metallic finish is attained.

■NOTE: Care must be taken not to remove an excessive amount of aluminum, or the crankcase must be replaced. If excessive aluminum is removed, too much pre-load will be exerted on the crankshaft bearings when assembled.

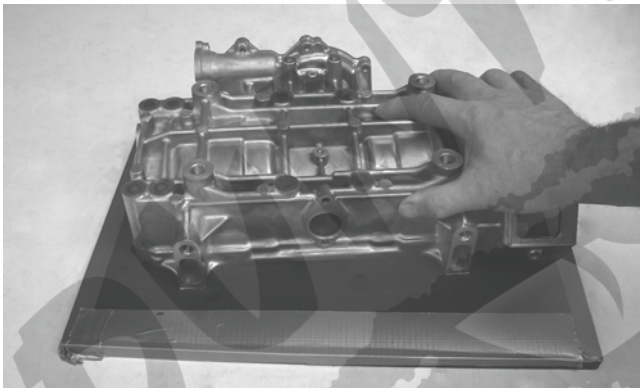

CM160

CAUTION

Water or parts-cleaning solvent must be used in conjunction with the wet-or-dry sandpaper or damage to the sealing surface may result.

■NOTE: At this point, install the coolant temperature sensor (threads coated with white Loctite #575) and tighten to 18 ft-lb.

CRANKSHAFT

■NOTE: If any servicing of the connecting rods, center bearings, or oil-injection pump drive gear is necessary, Arctic Cat recommends the crankshaft be taken to a qualified machine shop for that service.

1. Wash the crankshaft with bearings in parts-cleaning solvent.

2. Inspect the bearings for wear, scoring, scuffing, damage, or discoloration. Rotate the bearings. Bearings must rotate freely and must not bind or feel rough. If any abnormal condition is noted, replace the bearing.

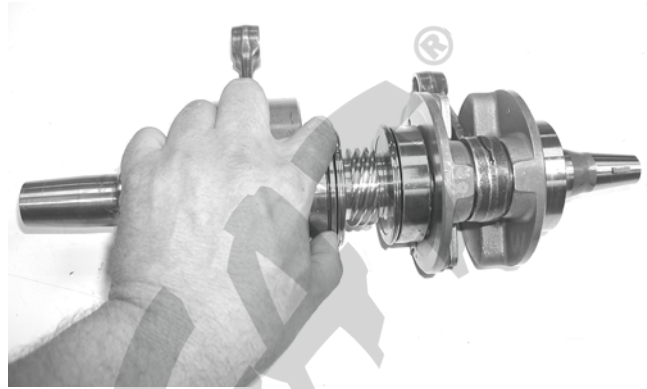

FC039

3. Inspect the connecting-rod bearings by rotating them. The bearings must rotate freely and must not bind or feel rough. If a connecting-rod bearing must be replaced, the connecting rod and crank pin must also be replaced.

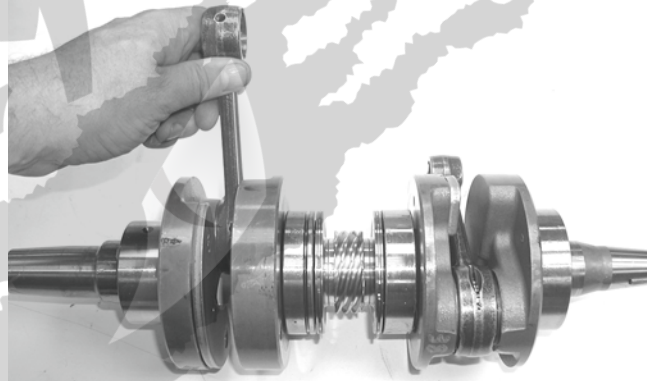

FC040

4. Inspect the oil-injection pump drive gear for any signs of worn or chipped teeth. If either condition exists, replace the gear.

■NOTE: Lubricate bearings thoroughly prior to assembly.

REMOVING/INSTALLING OUTER CRANKSHAFT BEARINGS

■NOTE: The end bearings are not pressed onto the crankshaft. The bearings can be removed simply by sliding them off the crankshaft.

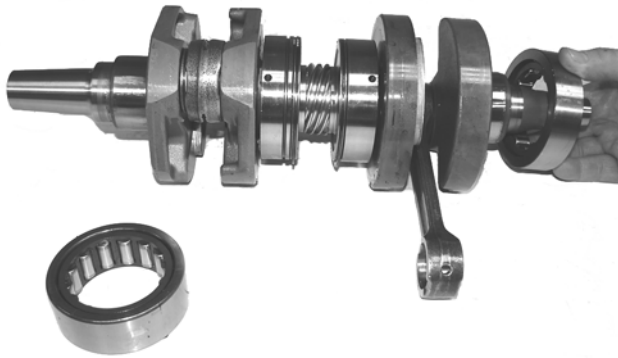

CM161

Inspect the crankshaft bearing area for wear. If any wear is noted on either end, replace the crankshaft end.

■NOTE: Install the bearings by sliding each bearing onto the crankshaft making sure the dowel-pin hole in the outer race is properly positioned and will align with its hole and pin in the crankcase.

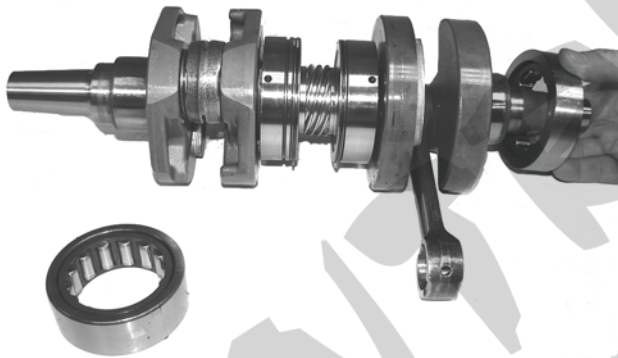

CM161

REED VALVE ASSEMBLY

1. Inspect the reed valves, stoppers, and valve blocks for cracks or any deterioration.

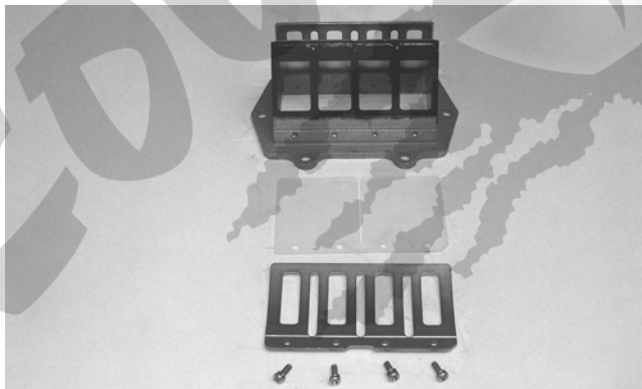

CM162

2. Wash the reed valves, stopper, and cage assembly in parts-cleaning solvent and blow dry.
3. Inspect the reed stopper height. Using a caliper, measure the distance from the seat to the bottom outer tip edge of the stopper. Measurement must not exceed specifications. If measurement is not within specifications, either bend or replace the reed stopper.

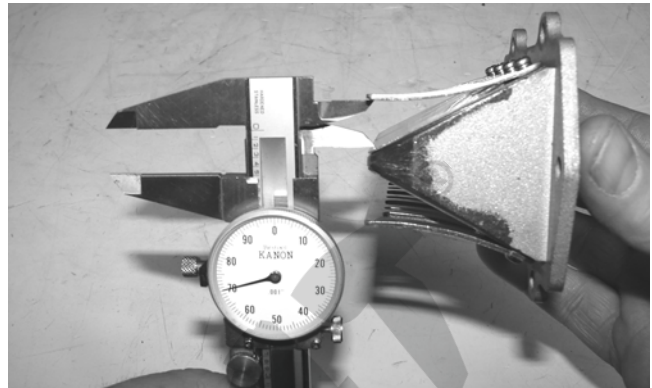

CM163

4. Inspect the reed-to-seat clearance. Using a feeler gauge, measure the clearance. Clearance must be less than 0.008 in. If clearance is not within specifications, replace the reed valve.
5. To assemble, place the reed valves on the cage with its clipped corner positioned to the lower right hand corner of the cage. Place the reed stopper assembly into position and secure with the screws tightened to 48 in.-lb.

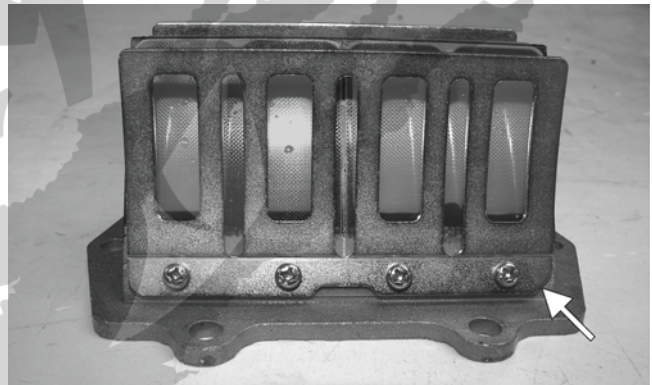

CM164A

Measuring Critical Components

■NOTE: Critical engine specifications chart can be found in Section 1 of this manual.

CYLINDER HEAD VOLUME (Squish-Gap Method)

To check the squish gap, a micrometer and two heavy pieces of solder will be needed.

1. Remove the spark plugs from the engine.
2. Simultaneously insert two pieces of solder down through the spark plug hole and push them up against the inner cylinder bore towards the MAG-side and PTO-side of the cylinder.
3. Pull the recoil rope and crank the engine over several times while the solder is being held firmly in place.
4. Remove both pieces of solder from the cylinder. Using the micrometer, measure the very end of the squeezed solder piece. Record the reading.

■NOTE: If the solder hasn't been squeezed by the piston, a larger piece of solder must be used. Repeat procedure.

- Using the opposite end of the solder pieces, insert them down through the spark plug hole towards the PTO-side and MAG-side of the cylinder. Push on the solder until they contact the inner cylinder bore.
- Pull the recoil rope and crank the engine over several times. Remove both pieces of solder from the cylinder and measure the opposite squeezed ends with a micrometer. Record reading.

■NOTE: Measure from PTO to MAG-side of the piston to accurately measure the squish gap. Never measure across piston, exhaust side to opposite side, as the piston will rock and the reading won't be accurate.

Readings may vary from side to side.

■NOTE: Make sure the smaller reading is 0.059 in. or less.

CYLINDER TRUENESS

- Measure each cylinder in the three locations from front to back and side to side for a total of six readings.

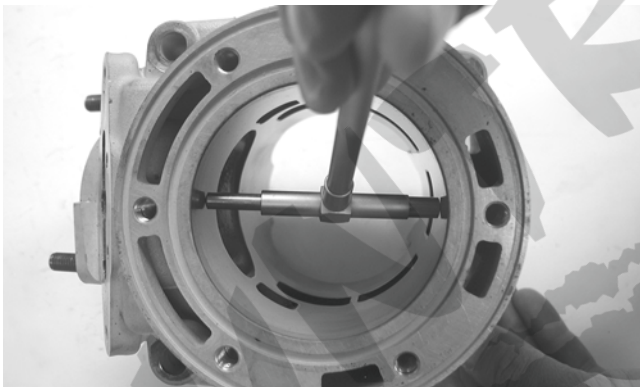

FC044

- The trueness (out-of-roundness) is the difference between the highest and lowest reading. Maximum trueness (out-of-roundness) must not exceed 0.004 in.

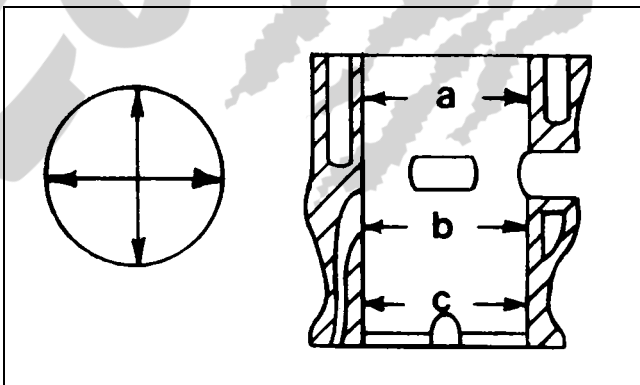

0725-586

PISTON SKIRT/CYLINDER CLEARANCE

- Measure each cylinder front to back about 1 in. from the bottom of each cylinder.
- Measure the corresponding piston skirt diameter at a point 1 cm above the piston skirt at a right angle to the piston-pin bore. Subtract this measurement from the measurement in step 1. The difference (clearance) must be within 0.0031-0.0041 in.

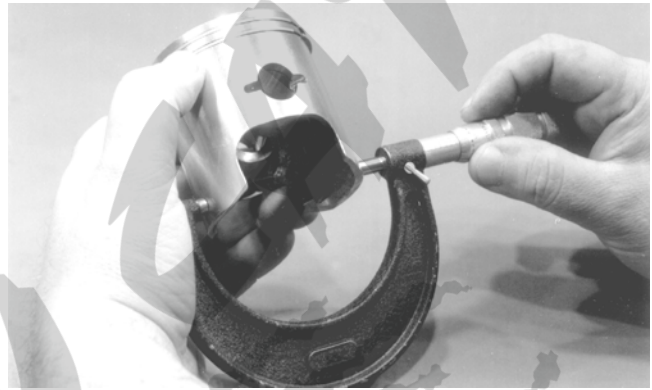

AC091

PISTON-RING END GAP

- Place each piston ring in the wear portion above the exhaust port of its respective cylinder. Use the piston to position each ring squarely in each cylinder.
- Using a feeler gauge, measure each piston-ring end gap. Acceptable ring end gap must be within 0.008-0.016 in.

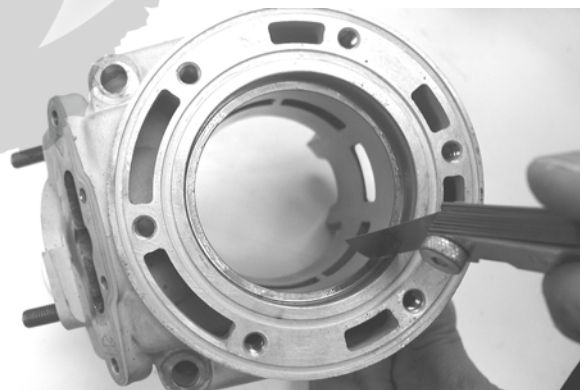

FC045

PISTON PIN

- Measure the piston pin diameter at each end and in the center. Acceptable piston pin measurement must be within 0.8659-0.8661 in. If any measurement varies by more than 0.001 in., the piston pin and bearing must be replaced as a set.

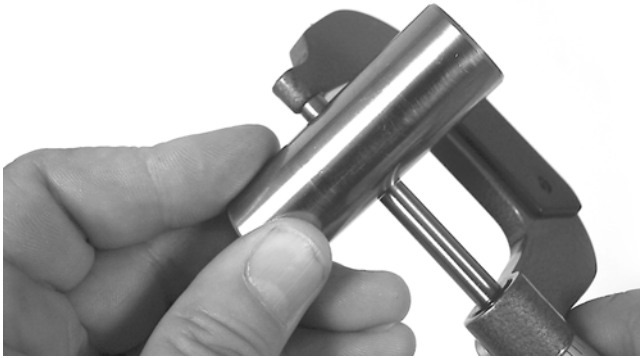

IO012

CRANKSHAFT RUNOUT

1. Using the V Blocks, support the crankshaft on the surface plate.

■NOTE: The V blocks should support the crankshaft on the outer bearings.

2. Mount a dial indicator and base on the surface plate. Position the indicator contact point against the crankshaft location point A (PTO-end) from the crankshaft end. Zero the indicator and rotate the crankshaft slowly. Note the amount of crankshaft runout (total indicator reading).

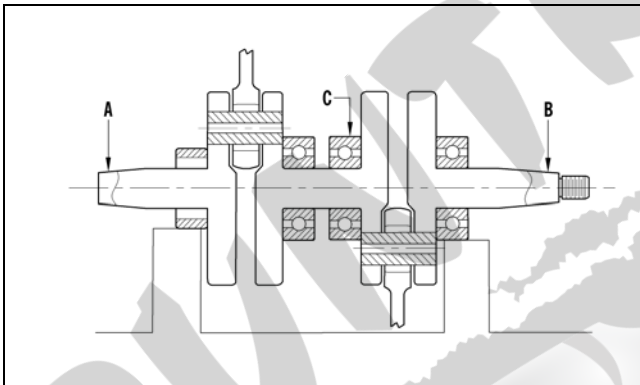

0742-727

■NOTE: For runout location point specifications, see Crankshaft Runout/Repair Specifications in Section 1 of this manual.

3. Position the indicator contact point against the crankshaft location point B (MAG-end) from the crankshaft end. Zero the indicator and rotate the crankshaft slowly. Note the amount of crankshaft runout (total indicator reading).

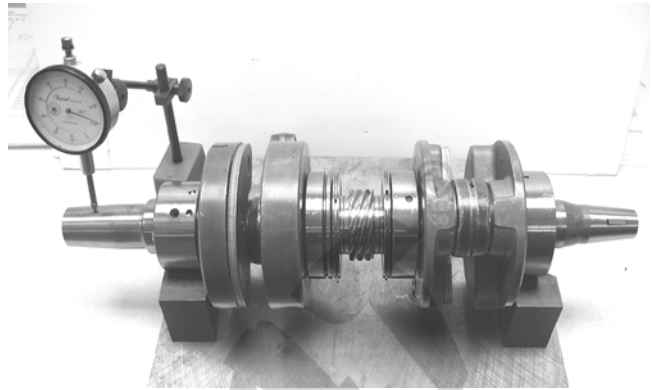

FC046

4. Position the indicator contact point against the crankshaft at location point C (center). Zero the indicator and rotate the crankshaft slowly. Note the amount of crankshaft runout (total indicator reading).
5. If runout exceeds 0.002 in. at any of the checkpoints, the crankshaft must be either straightened or replaced.

Assembling

■NOTE: The use of new gaskets and seals is recommended when assembling the engine.

■NOTE: Prior to assembling the engine, use parts cleaning solvent and compressed air and thoroughly clean the threaded holes of the crankcase and cylinders to properly tighten.

⚠ WARNING

Always wear safety glasses when drying components with compressed air.

■NOTE: When the use of a lubricant is indicated, use Arctic Cat Synthetic APV 2-Cycle Oil.

1. Apply a thin coat of grease to the inner seal lips of the water pump seal.
2. Using the seal driver, position the inner water pump shaft seal onto the seal driver and gently tap the seal down into position.

■NOTE: Grease must be applied to the lips of the inner seal before installation.

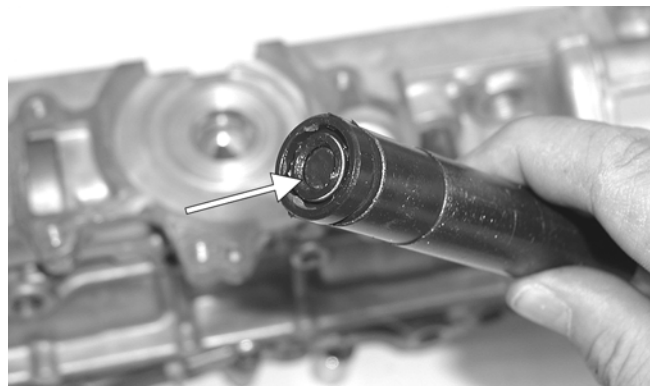

MS986A

■NOTE: The seal must be installed with its spring side towards the crankshaft.

3. Install the snap ring securing the inner seal in the crankcase.

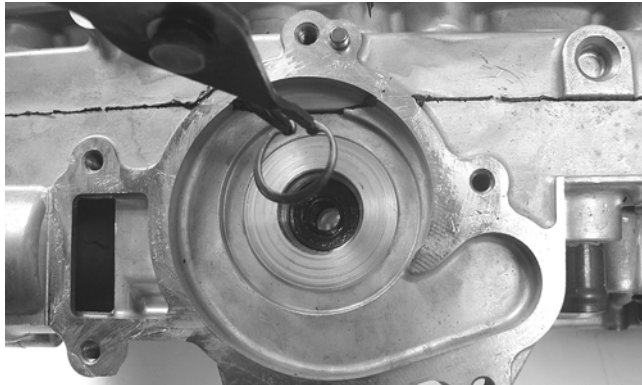

MS415

4. Using the seal driver, carefully install the outer water pump seal. Gently tap the seal down into position until it seats itself against its flange.

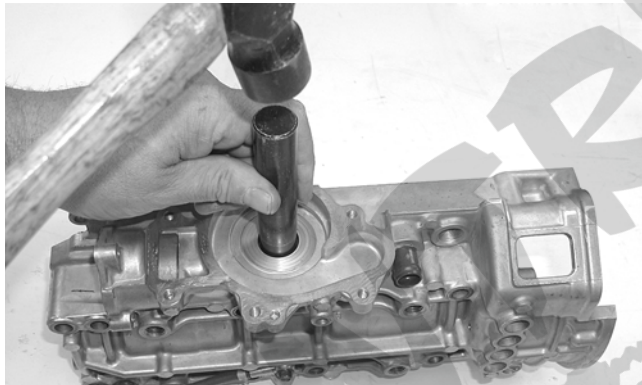

MS988

5. Position the upper crankcase half upside-down on two wooden blocks; then install the C-ring, the four bearing retaining pins, and the two crankcase dowel pins.
6. Place the PTO-side crankshaft bearing into position making sure the bearing retaining pin hole is positioned inward.

■NOTE: The bearing retaining pin hole is the hole that doesn't go entirely through the bearing case.

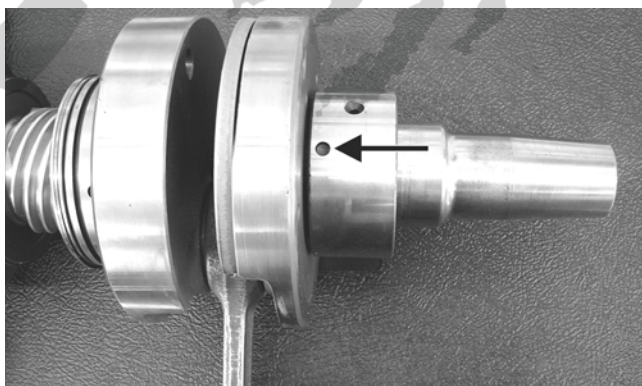

CM043A

7. Lubricate the inner lips of the crankshaft oil seals with grease; then slide the seals onto the crankshaft making sure the spring side of each seal faces the center of the crankshaft.
8. Apply oil to the crankshaft bearings; then install the crankshaft into the upper crankcase half. Be sure the alignment hole in each bearing is positioned over its respective dowel pin in the crankcase; then seat the crankshaft.

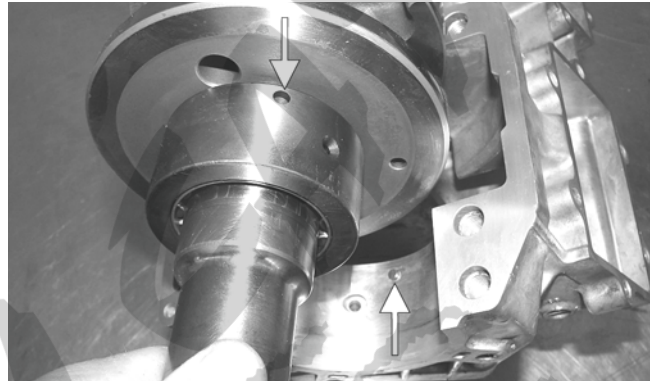

CM045A

■NOTE: To check the bearing for proper position, place the point of a sharp tool into the dimple found in the bearing race. Strike the tool with the palm of the hand in either direction. If the bearing moves, it isn't positioned correctly and must be rotated until it drops onto the dowel pin.

CAUTION

If the bearings are not properly seated during assembly, the crankcase halves will not seal tightly and severe engine damage will result.

9. Position the two center seal rings with their end gaps 180° apart (up on one and down on the other); then apply a thin coat of High-Temp Sealant to the entire bottom half of the crankcase sealing surface.

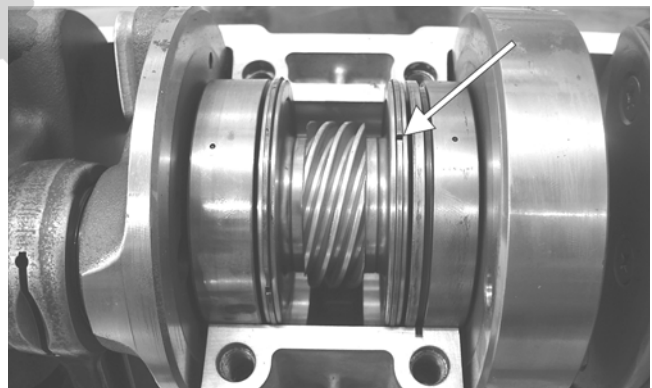

CM036A

■NOTE: At this point if the coolant temperature sensor was removed, install the sensor (threads coated with white Loctite #575) and tighten to 18 ft-lb.

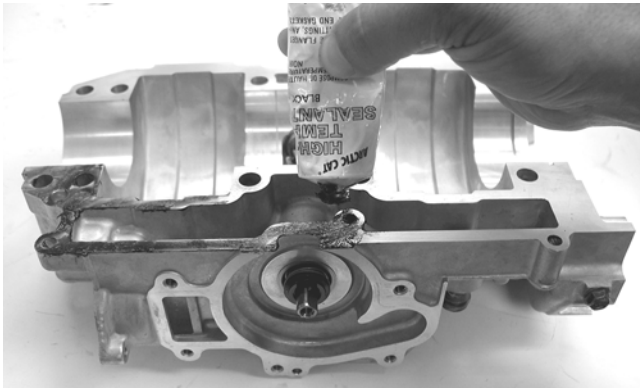

FC071

10. Assemble the crankcase halves making sure the crankshaft gear and oil-injection pump driveshaft gears mesh. Rotate the crankshaft one full turn to align the crankshaft gear and pump driveshaft.
11. Install the crankcase cap screws securing the crankcase halves.
12. Tighten the 6 mm cap screw to 96 in.-lb, the 8 mm cap screws to 18 ft-lb, and the ten 10 mm cap screws in two steps from 13 ft-lb to 37 ft-lb using the pattern shown.

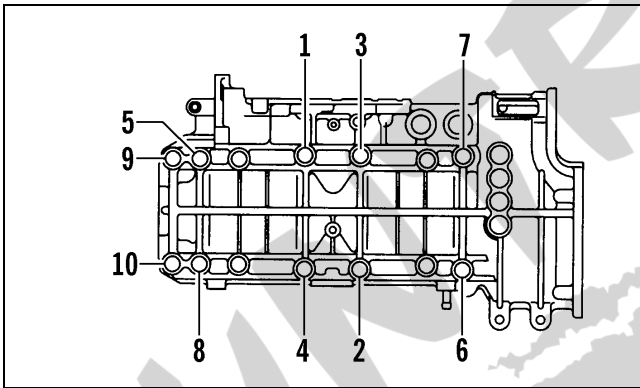

0738-201

■NOTE: After tightening the crankcase, turn the engine right side up and tighten the four MAG-housing cap screws in a crisscross pattern to 18 ft-lb.

■NOTE: Secure the connecting rods with rubber bands on the cylinder studs.

13. Apply a thin coat of grease to the sealing surface of the oil-injection pump/water pump driveshaft; then place the Oil Seal Protector Tool at the end of the shaft.

CAUTION

Be very careful not to damage the seals when installing the oil pump driveshaft. Twist the driveshaft clockwise as it enters the seal area and while pushing it through the seals.



FS191

14. Rotate the oil-injection pump/water pump driveshaft while carefully pushing it through the oil and water pump seals until the driveshaft and crankshaft gears engage; then remove the oil seal protector tool (A) from the end of the shaft.

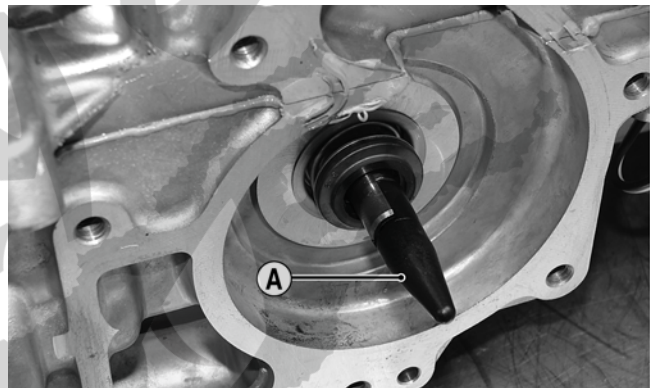

IO025A

15. Position the shim (A) on the oil-injection pump end of the driveshaft; then with a new O-ring (lightly coated with oil) in place, install the oil-injection pump retainer (B).

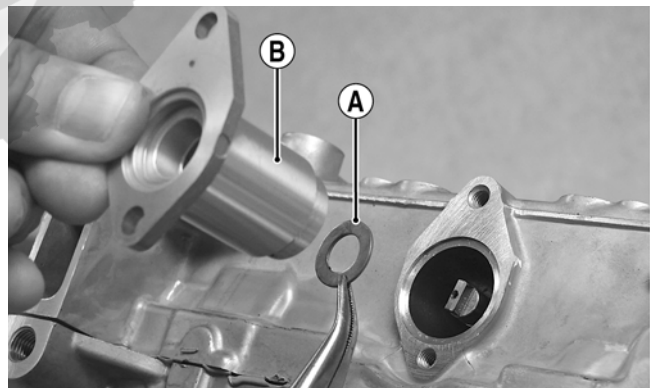

IO026A

16. With a new O-ring (lightly coated with oil) in place, install the oil-injection pump making sure the pump shaft slot and pump driven gear shaft align. Secure with two screws (coated with blue Loctite #243). Tighten the two screws to 96 in.-lb.

CAUTION

Be sure the oil-injection pump/water pump driveshaft is properly aligned with the slot of the oil-injection pump to avoid damage.

17. Position the ceramic/rubber seal retainer and seal into the back side of the water pump impeller with the ceramic face of the seal directed out.

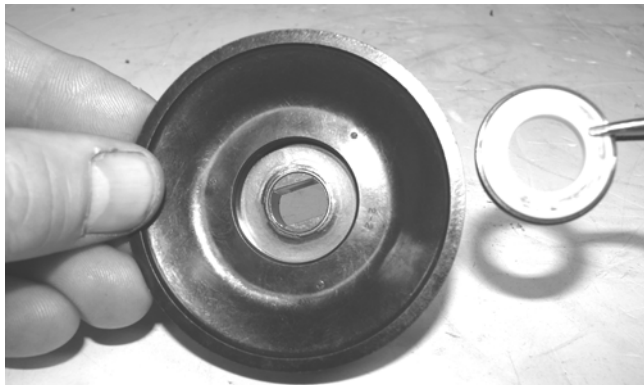

CM168

18. Using a suitable tool, press the seal into position making sure its marked side is positioned towards the rubber seal cup; then apply a thin coat of grease to the seal outer surface.

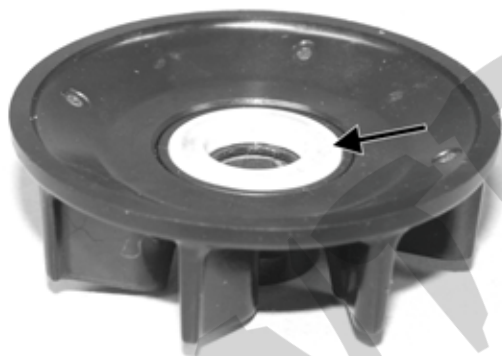

IO050A

CAUTION

When installing the ceramic/rubber seal into the impeller, never touch the ceramic part of the seal. Make sure components are clean and free of any dirt or contaminants.

19. Place the impeller into position and secure with a cap screw and washer. Be sure the rubber side of the washer is lubricated with a light coat of grease and directed toward the impeller. Apply blue Loctite #243 to the threads of the cap screw and tighten to 108 in.-lb.

■NOTE: For assembling purposes, lubricate the rubber side of the washer before installing.

CAUTION

If the rubber side of the washer is not positioned toward the impeller, a coolant leak will result.

20. Apply High-Temp Sealant to the crankcase/water pump cover seam (A); then install the dowel pins (C) into the crankcase.

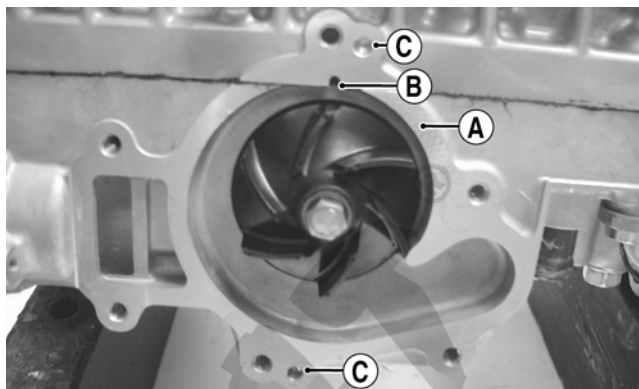

FC072C

■NOTE: Do not allow sealant into the breather hole (B) in the crankcase. If sealant gets into the hole, carefully remove before proceeding.

21. Position the O-ring (lightly coated with oil) into the water pump cover; then install the cover. Secure with six screws; then using the pattern shown, tighten to 96 in.-lb.

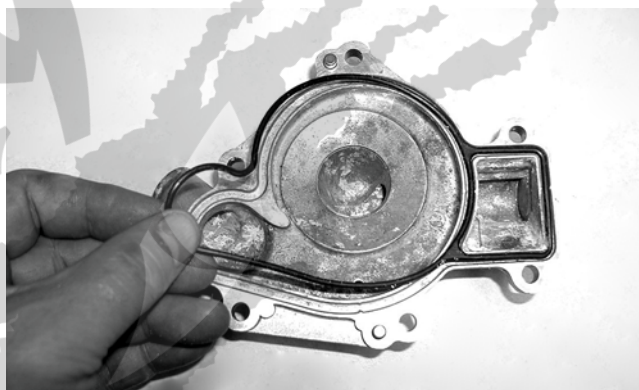

FC134

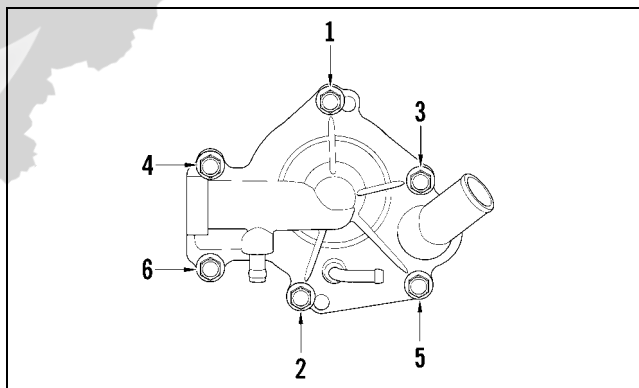

0742-304

22. Noting the alignment dots, install the thermostat housing with thermostat. Secure the housing with cap screws and tighten to 96 in.-lb.

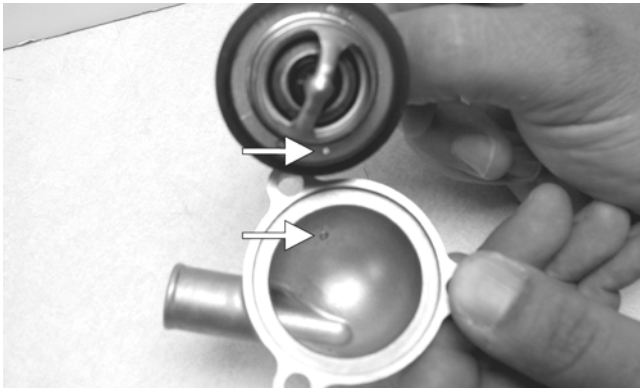

FC078A

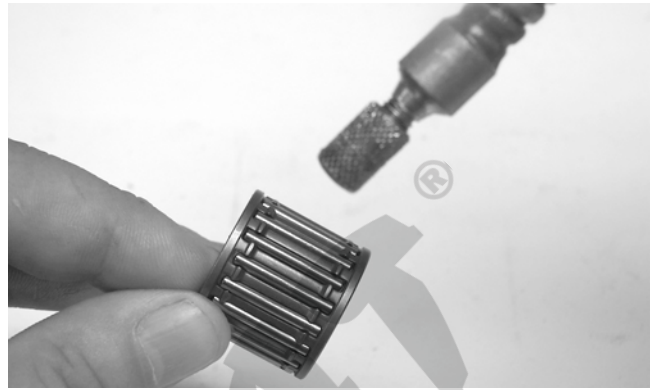

TZ068

■NOTE: The shoulder side of the washer must seat to the needle bearing.

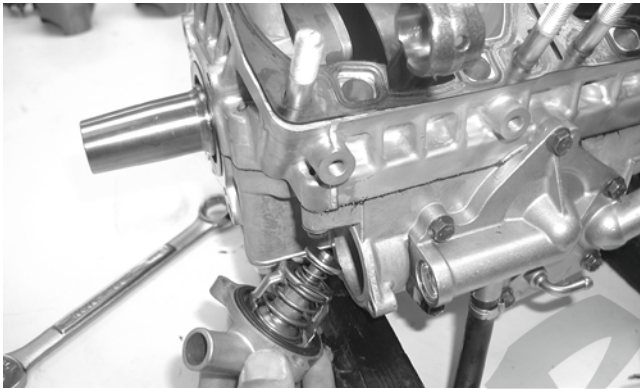

FC073

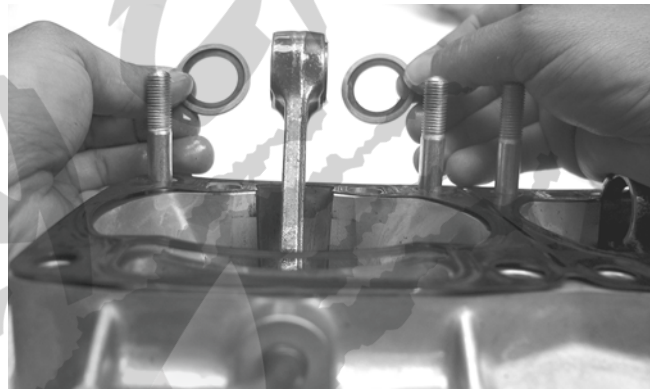

FC075

23. With new gaskets, install the reed valve assemblies; then secure the intake flanges to the crankcase. Tighten in a crisscross pattern to 96 in.-lb.
24. Install the dowel pins into the crankcase; then place the cylinder base gasket into position on the crankcase.
25. Install the piston rings on each piston so the letter on the top (inclined surface) of each ring faces the dome of the piston.

27. Place each piston over the connecting rod so the indicator dot on each piston will point toward the intake/exhaust ports; then secure with an oiled piston pin.

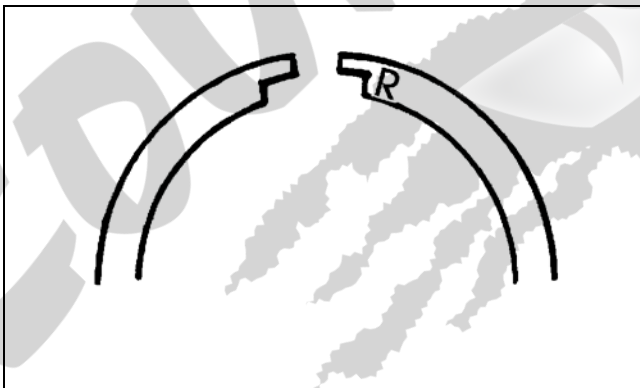

726-306A

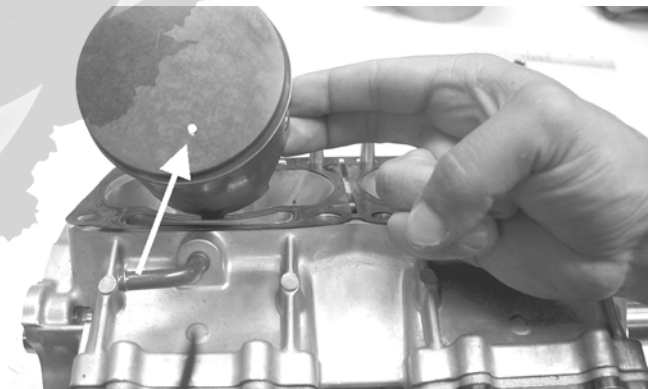

FC079A

28. Install the new circlips so the open end is directed either up or down.

CAUTION

Incorrect installation of the piston rings will result in engine damage.

26. Apply oil to the connecting-rod small end bearings; then install the small-end bearings. Install a washer on each side of the connecting rod.

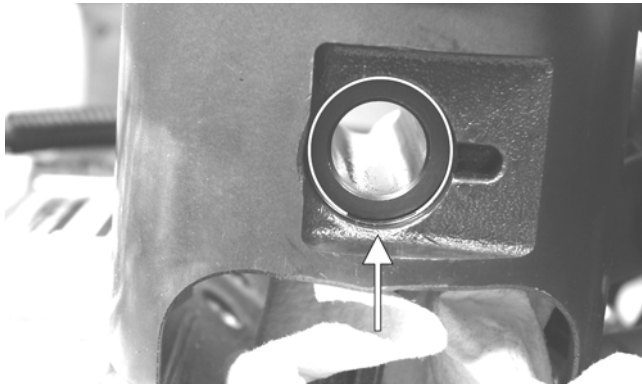

CM195B

■NOTE: Install the circlip to the inside of the piston before installing the connecting rod.

CAUTION

Make sure the circlips are firmly seated before continuing with assembly.

29. Rotate each piston ring until the ring ends are properly positioned on either side of the ring keeper; then apply oil to the piston assemblies and cylinder bores. Remove the rubber bands or hoses from the connecting rods.
30. In turn on each cylinder, place a piston holder (or suitable substitute) beneath the piston skirt and square the piston in respect to the crankcase; then using a ring compressor or fingers, compress the rings and slide the cylinder over the piston. Remove the piston holder and seat the cylinder firmly onto the crankcase.

■NOTE: The cylinders should slide on easily. DO NOT force the cylinders on.



FC076

31. Secure each cylinder by installing the eight nuts. DO NOT TIGHTEN AT THIS TIME.
32. Install the oil-injection hoses and secure with the clamps; then place the lower check-valve assembly into position and secure with the gaskets and union cap screw. Tighten to 48 in.-lb.
33. Secure the cylinders (from step 31) by tightening the cylinder base nuts to 44 ft-lb in three steps using the pattern shown.

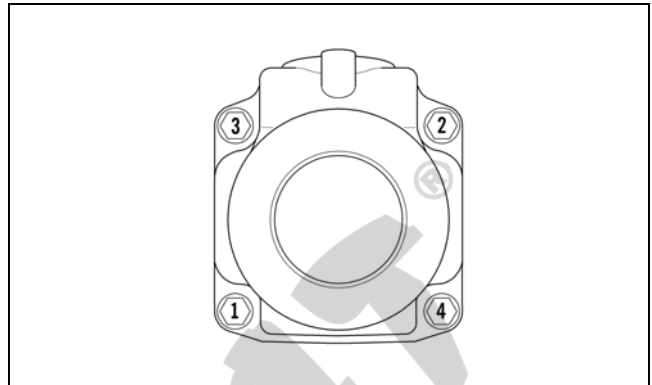

0742-746

34. Install the two cylinder O-rings (lightly coated with oil) on the top of each cylinder making sure they are correctly positioned in the grooves.



FC077

35. Place new O-rings (lightly coated with oil) onto each of the head cap screws. Place four of these cap screws into the cylinder head. Thread the spark plugs in part way; then while holding the head above the cylinder, carefully start and finger-tighten all four cap screws while observing the cylinder O-rings to make sure they remain in position. Slowly place the head into position on top of the O-rings. Start and finger-tighten the remaining cap screws being very careful not to move the cylinder head.
36. From step 35 in two steps, tighten the 8 mm cap screws to 19 ft-lb using the appropriate pattern shown. Install the spark plugs.

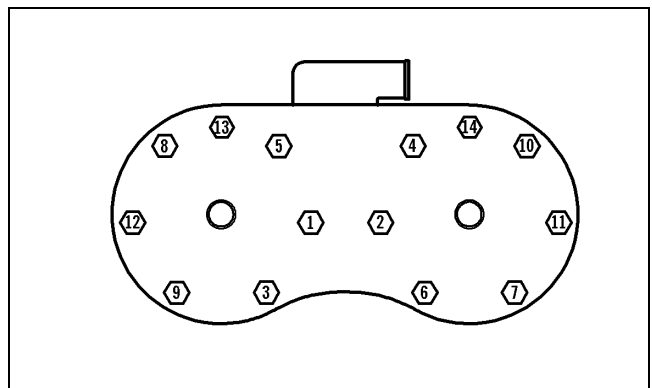

0738-204

■NOTE: After tightening the 8 mm cap screws, tighten the two remaining 6 mm cap screws to 96 in.-lb.

■NOTE: At this point, pressure test the engine (see Section 3).

37. Secure the stator plate to the crankcase with the Allen-head cap screws (coated with blue Loctite #243) and tighten to 96 in.-lb.

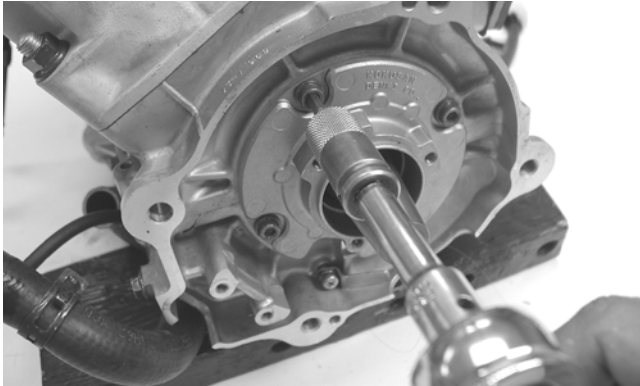

FC021

38. Secure the ignition timing sensor with screws coated with blue Loctite #243. Tighten to 48 in.-lb. Install the stator assembly with wires and a grommet into the crankcase and secure with the Allen-head screws (coated with blue Loctite #243). Tighten to 96 in.-lb.

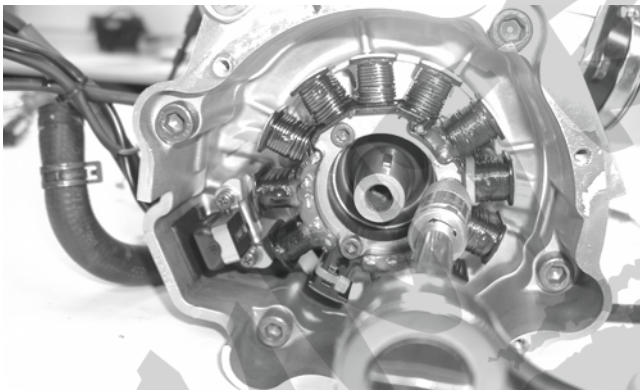

FC018

39. Install the key in the crankshaft.
40. Thread two puller bolts into the flywheel; then slide the flywheel onto the crankshaft making sure the keyways match. Remove the puller bolts.
- NOTE: Before installing the flywheel, be sure to wipe the crankshaft and flywheel tapers clean using a clean towel.
41. Apply red Loctite #271 to the threads of the flywheel cap screw; then finger-tighten with a large flat washer. DO NOT TIGHTEN AT THIS TIME.

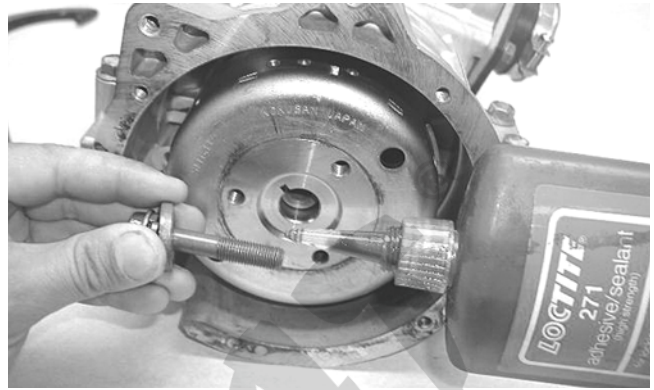

FC080

42. Secure the starter pulley to the flywheel with three cap screws and using the spanner wrench, tighten the cap screws evenly to 19 ft-lb; then tighten the flywheel cap screw (from step 41) to 50 ft-lb.

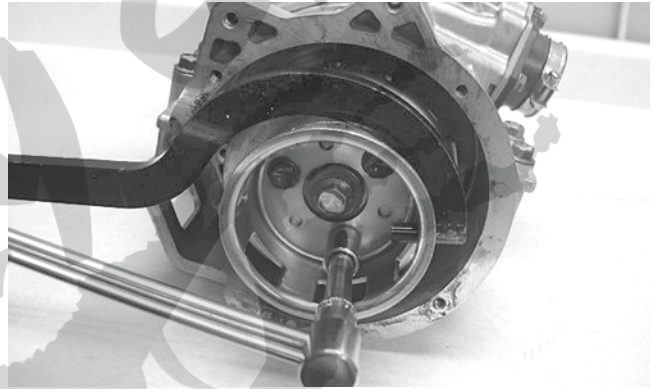

FC081

43. Install the coolant supply hose to the water pump and cylinder hose; then install the overflow hose and secure with the clamps.
44. Install the exhaust manifold using new gaskets and the existing flange nuts. Tighten to 17 ft-lb.

Engine Servicing - 6000

This engine sub-section has been organized to show a progression for servicing of the Arctic Cat 6000 engine. For consistency purposes, this sub-section shows a complete and thorough progression; however, for efficiency it may be preferable to disassemble only those components needing to be addressed. Also, some components may vary from model to model. The technician should use discretion and sound judgment.

SPECIAL TOOLS

A number of special tools must be available to the technician when performing service procedures in this engine section.

Description	p/n
Ball Hone	0644-294
Flywheel Spanner Wrench	0144-007
Flywheel Puller	0744-040
Flywheel Puller Insert	0644-568
Extractor Nut (Medium)	0643-074
Oil Seal Protector Tool	0644-219
Piston Pin Puller	0644-328
Surface Plate	0644-016
Water Pump Bearing and Seal Tool Kit	0644-557
V Blocks	0644-535
Vacuum Test Pump	0644-131

■NOTE: Special tools are available from the Arctic Cat Service Parts Department.

Disassembling

■NOTE: When disassembling top-side components, mark MAG-side and PTO-side components for assembling purposes.

- Using the Flywheel Spanner Wrench to secure the flywheel, remove the flywheel cap screw and washer; then remove the cap screws securing the recoil cup.

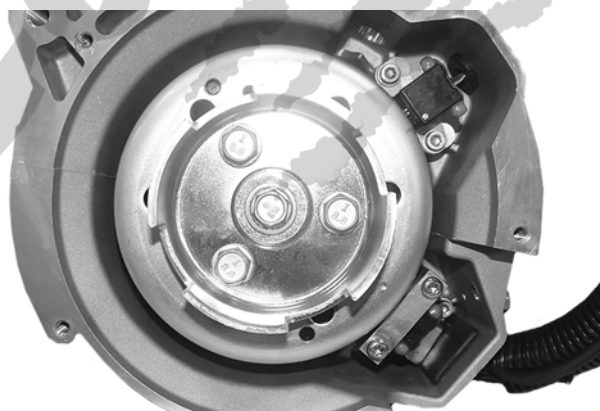

CWI-070

- Install the Flywheel Puller Insert onto the end of the crankshaft.

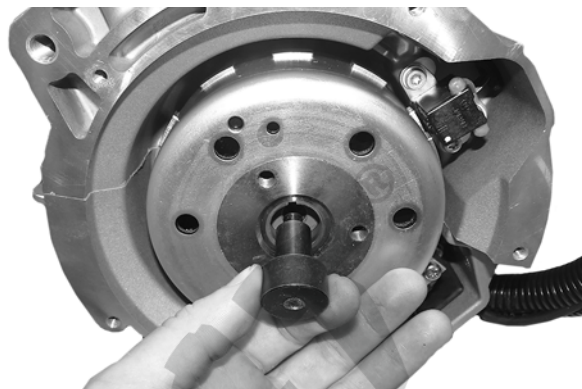

CWI-072

- Using Flywheel Puller or suitable substitute, remove the flywheel from the crankshaft by tightening the puller bolt using an pneumatic gun. Account for the key.

CAUTION

To prevent damage to the crankshaft, do not thread puller bolts more than 1/2 in. into the flywheel. Damage to the stator may result.

■NOTE: To ensure the cleanliness of the flywheel magnets, place the flywheel (with the magnets facing upward) on a clean bench.

- Remove the cap screw securing the ground wire to the crankcase.
- Remove the screw (A) securing the stator lead wire plate to the crankcase; then remove the screws (B) securing the timing sensors and bracket, remove the sensors, and account for the harness grommets.

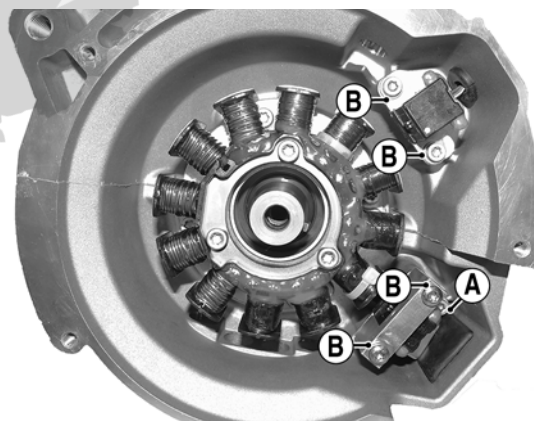

CWI-074A

- Remove the screws securing the stator to the stator plate. Route the stator lead wire out of the crankcase; then remove the stator assembly.
- Remove the screws securing the stator plate to the engine; then remove the plate.

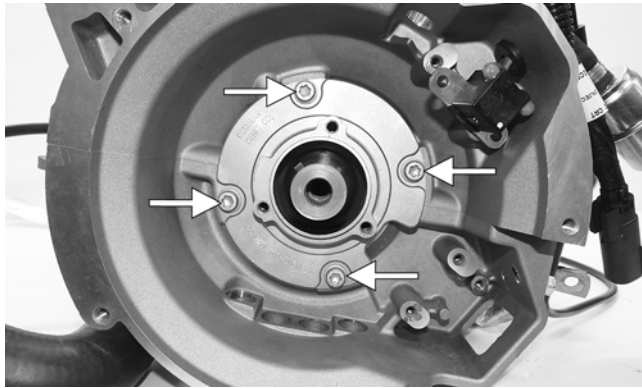

CWI-005A

■NOTE: For assembling purposes, note the indentation (A) of the stator plate is aligned with the harness opening (B) in the crankcase.

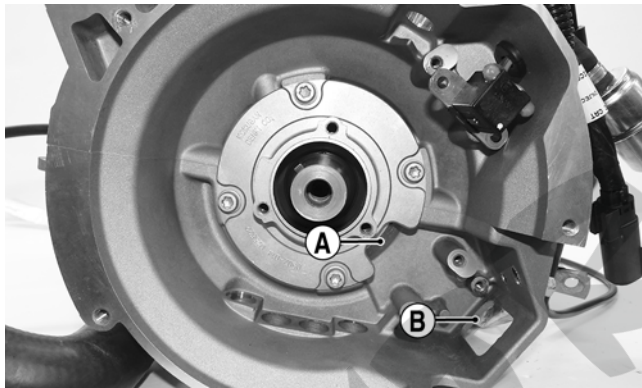

CWI-005B

■NOTE: The stator plate screws have Loctite applied to the threads during assembly. Using an impact driver, apply a sharp blow to the head of each screw to break the Loctite loose before removal.

8. Remove the cap screws securing the APV assemblies to the cylinders; then remove the APV assemblies and set them aside. Account for all four dowel pins and make sure the pins do not fall into the engine.

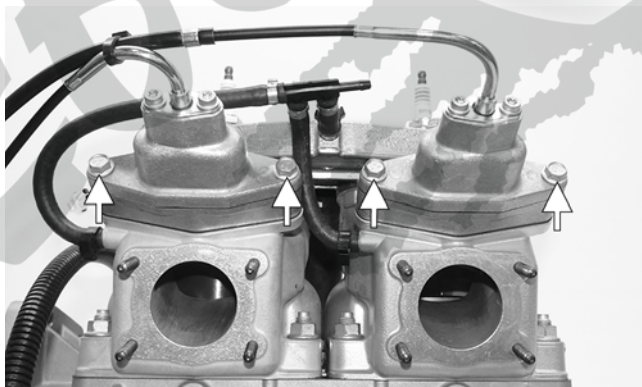

CWI-006A

9. Disconnect the coolant hose from the back of the cylinder head.
10. Remove the cap screws with O-rings securing the cylinder head (in the order shown); then separate the head from the cylinders. Account for the O-rings on top of the cylinders.

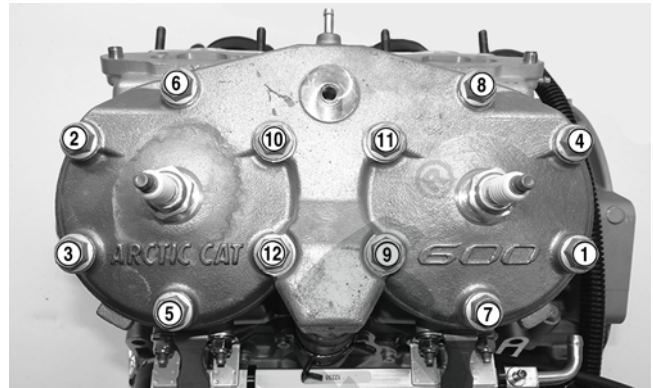

CWI-009

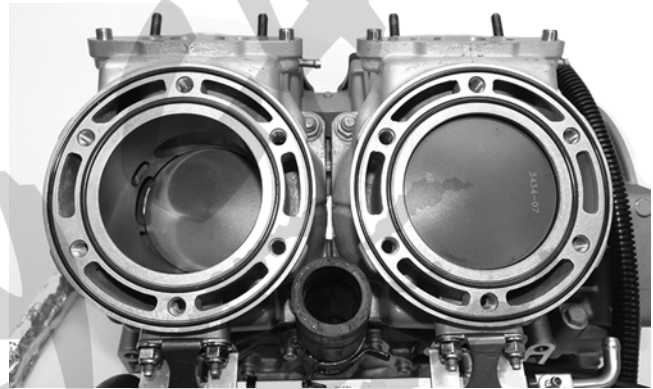

CWI-010

11. Remove the four nuts securing the fuel rail to the back of the cylinders; then remove the fuel rail and injectors as an assembly. Account for all gaskets.



CWI-011A

12. Remove the eight nuts securing the cylinders to the crankcase; then using a soft hammer, gently tap the cylinders and remove from the crankcase by lifting them straight up off their studs. Account for a gasket and alignment pins.

CAUTION

When removing a cylinder, be sure to support the piston to prevent damage to the crankcase and piston.



CWI-012

13. Remove the PTO-side piston-pin circlip from the PTO-side piston; then remove the MAG-side piston-pin circlip from the MAG-side piston.



CWI-015

16. Remove the screws securing the intake flanges. Remove the intake manifolds and reed valve assemblies.



CWI-013A

14. Using Piston Pin Puller and medium Extractor Nut, remove the piston pins from both pistons.

■NOTE: For proper assembly, keep all MAG-side components and all PTO-side components separated. Assemble them on their proper sides.

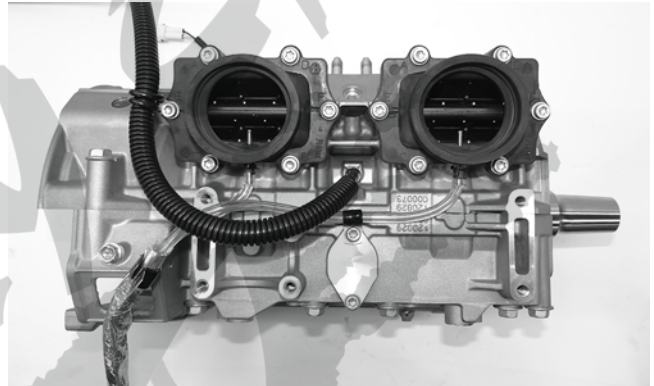

CWI-020



CWI-014

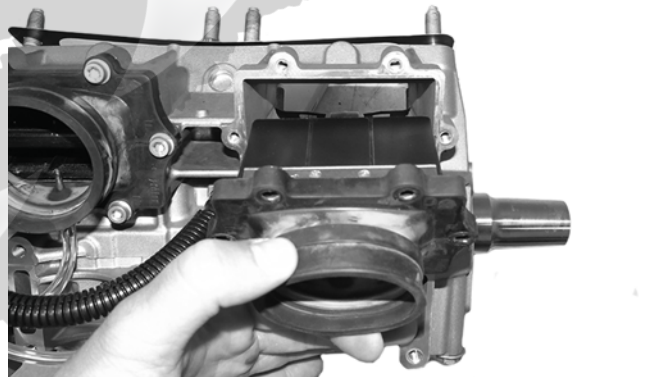

CWI-081

17. Remove the four screws securing the thermostat cap; then remove the cap, gasket, and thermostat.

CAUTION
DO NOT use any type of punch to drive the piston pin free of the piston; damage may result. Use a piston-pin puller only.

15. Lift the pistons clear of the connecting rods and remove the small-end connecting-rod bearings; then remove the piston rings. Keep each piston with its rings; keep each piston pin and bearing together as a set.

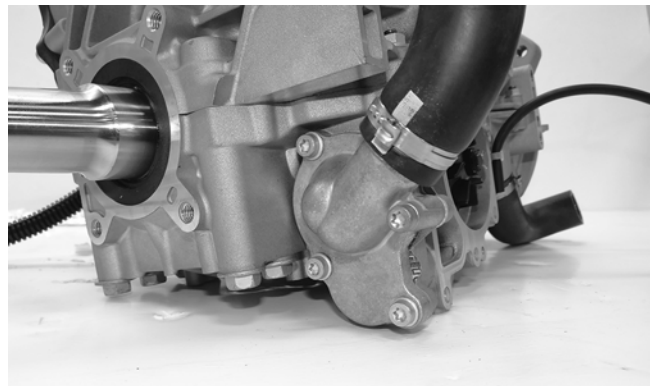

CWI-017

■NOTE: For assembling purposes, note that the bypass/check valve is directed up.

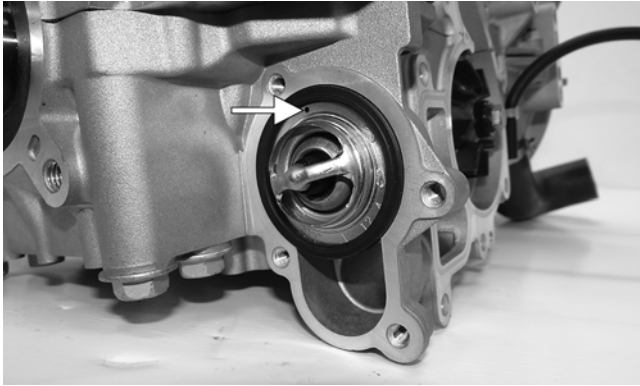

CWI-018A

18. Remove the seven screws securing the water pump cover to the crankcase and remove the cover. Account for the O-ring gasket and the alignment pins.

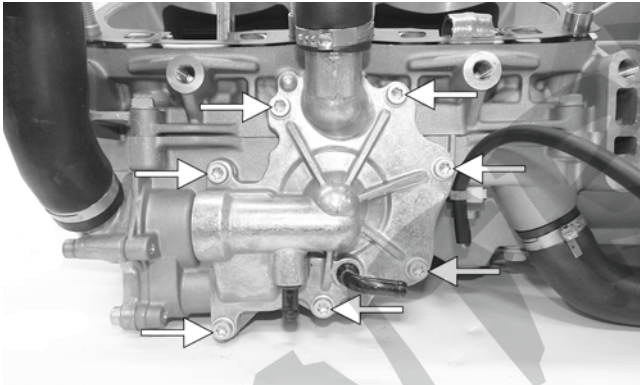

CWI-016A

19. Remove the cap screw securing the impeller. Account for the rubber washer and gasket behind the cap screw. Remove the impeller from the shaft.



CWI-082

20. Prior to turning the engine upside down, remove the two crankcase torx screws (A) from the water pump side of the engine; then remove the two cap screws (B) from the magneto housing.

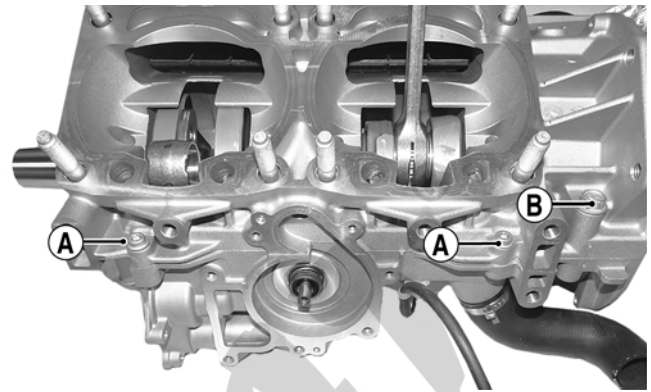

CWI-075A

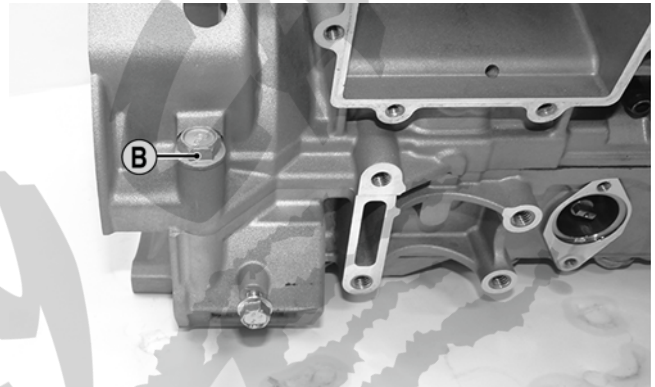

CWI-023A

21. Tip the crankcase assembly up onto the water pump side; then remove the black torx-screw from the bottom of the crankcase and tip down and drain the injection oil from the center cavity into a container.

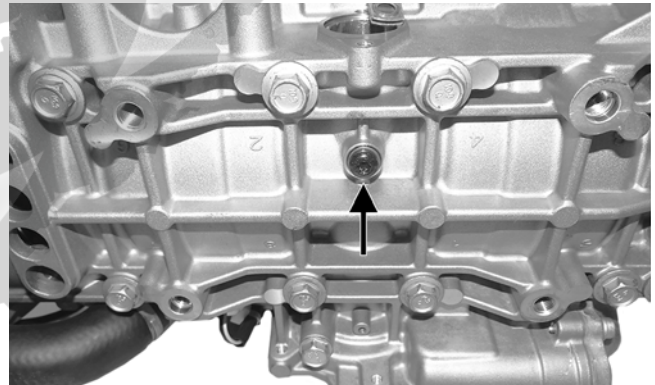

CWI-023A

22. With the bottom side up on two support blocks, remove the cap screws securing the crankcase halves.

■NOTE: Remove the cap screws in order from #10 to #1. The numbers are embossed next to each cap screw.

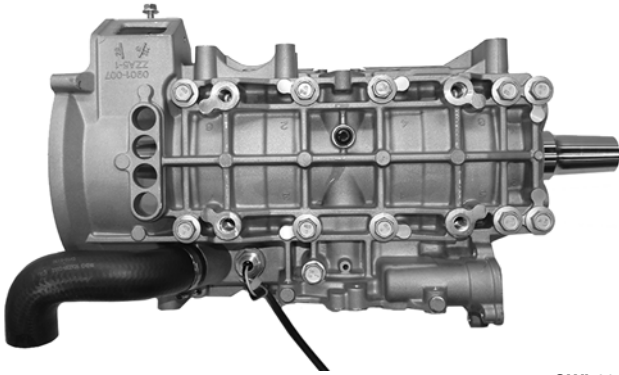

CWI-024

23. With all screws removed, carefully separate the crankcase halves in locations shown below only.

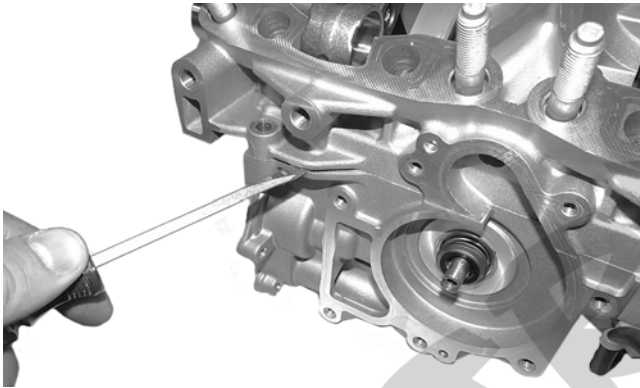

CWI-076

CAUTION

DO NOT drive any tool between halves (sealing surface) to separate the crankcase. Damage to the sealing surfaces will result.

24. Lift the bottom half of the crankcase off the top half.

CAUTION

Care must be taken to not allow the connecting rods to drop onto the sealing surface of the bottom case half.

25. Lift the crankshaft free from the top half of the crankcase and slide the crankshaft bearings and oil seals off the crankshaft. Account for the C-ring (A). Remove the bearing retaining pins (B) and account for the crankcase dowel pins (C).

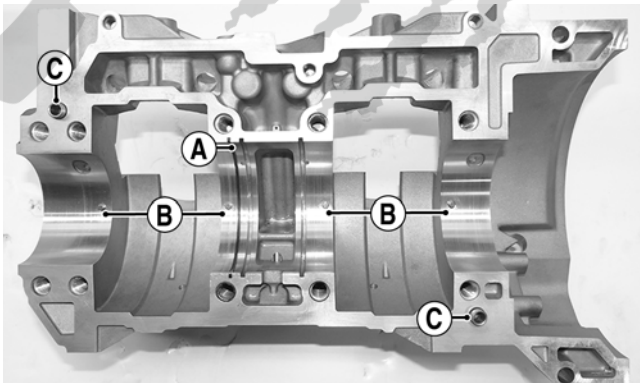

CWI-027A

26. Remove the water pump driveshaft from the lower crankcase half. Account for the thrust washer on the outer end of the shaft.

■NOTE: When replacing the inner water pump seals, use the recommended Water Pump Bearing and Seal Tool Kit only.

27. Place the lower crankcase on the bench with the water pump side down. Using the long seal driver, drive the mechanical water pump seal from the crankcase.

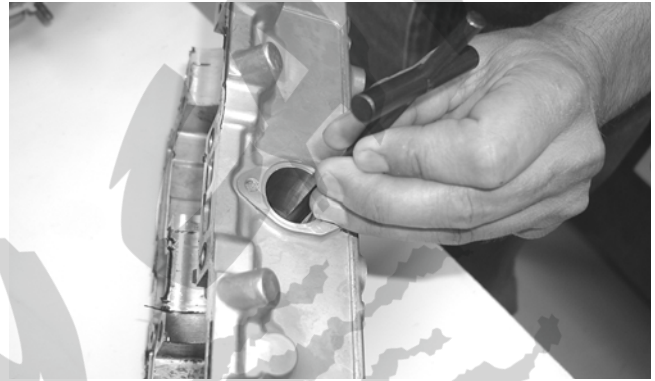

FC036

28. Using a pair of snap ring pliers, remove the snap ring securing the inner seal in the crankcase.

29. Using the hooked end of the tool, pull the inner seal free of the crankcase.

30. Using the hooked end of the tool, pry the seal ring from the backside of the water pump impeller.

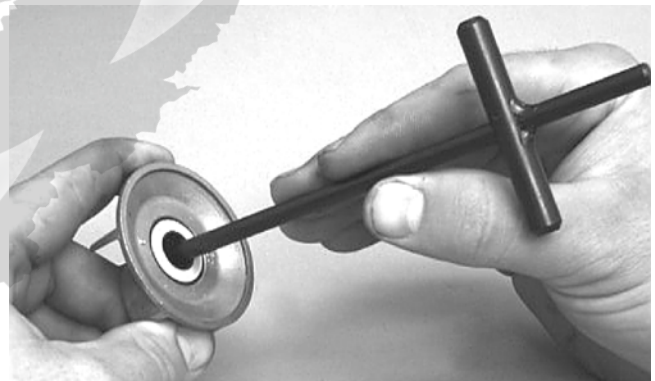

AN327D

Cleaning and Inspecting

CYLINDER HEAD

1. Using a non-metallic carbon removal tool, remove any carbon buildup from the combustion chambers being careful not to nick, scrape, or damage the combustion chambers or the sealing surfaces.
2. Inspect the spark-plug holes for any damaged threads.

■NOTE: If warpage is suspected, have a qualified machine shop inspect and repair if necessary.

- Place the cylinder head on a Surface Plate covered with #400 grit wet-or-dry sandpaper. Using light pressure, move each cylinder head in a figure eight motion. Inspect the sealing surface for any indication of high spots. A high spot can be noted by a bright metallic finish. Correct any high spots before assembly by continuing to move the cylinder head in a figure eight motion until a uniform bright metallic finish is attained.

CAUTION

Water or parts-cleaning solvent must be used in conjunction with the wet-or-dry sandpaper or damage to the sealing surface may result.

CYLINDERS

- Using a non-metallic carbon removal tool, remove carbon buildup from the exhaust ports.
- Wash the cylinders in parts-cleaning solvent.
- Inspect the cylinders for pitting, scoring, scuffing, and corrosion. If marks are found, repair the surface with the Ball Hone and honing oil.

■NOTE: To produce the proper 45° crosshatch pattern, maintain a low drill RPM. If honing oil is not available, use a lightweight, petroleum-based oil. Thoroughly clean the cylinders after honing using detergent soap and hot water and dry with compressed air; then immediately apply oil to the cylinder bores. If a bore is severely damaged or gouged, the cylinder must be replaced or replated.

- Place the head surface of each cylinder on the surface plate covered with #400 grit wet-or-dry sandpaper. Using light pressure, move each cylinder in a figure eight motion. Inspect the surface for any indication of high spots. A high spot can be noted by a bright metallic finish. Correct any high spots before assembly by continuing to move the cylinder in a figure eight motion until a uniform bright metallic finish is attained.

CAUTION

Water or parts-cleaning solvent must be used in conjunction with the wet-or-dry sandpaper or damage to the sealing surface may result.

PISTON

- Using a non-metallic carbon removal tool, remove the carbon buildup from the dome of each piston.

CRANKCASE

- Scrape of any residual silicone from both the top and bottom crankcase halves making sure not to damage the sealing surface; then wash the crankcase halves in parts-cleaning solvent.

■NOTE: Before washing the crankcase halves, make sure the four bearing dowel pins have been removed and accounted for.

- Inspect the crankcase halves for scoring, pitting, scuffing, or any imperfections in the casting.

- Inspect all threaded areas for damaged or stripped threads.
- Inspect the bearing areas for cracks or excessive bearing movement. If evidence of excessive bearing movement is noted, the crankcase must be replaced.
- Inspect the bearing dowel pins for wear.
- Inspect the sealing surfaces of the crankcase halves for trueness by placing each crankcase half on the surface plate covered with #400 grit wet-or-dry sandpaper. Using light pressure, move each half in a figure eight motion. Inspect the sealing surfaces for any indication of high spots. A high spot can be noted by a bright metallic finish. Correct any high spots by continuing to move the half in a figure eight motion until a uniform bright metallic finish is attained.

■NOTE: Care must be taken not to remove an excessive amount of aluminum, or the crankcase must be replaced. If excessive aluminum is removed, too much pre-load will be exerted on the crankshaft bearings when assembled.

CAUTION

Water or parts-cleaning solvent must be used in conjunction with the wet-or-dry sandpaper or damage to the sealing surface may result.

CRANKSHAFT

■NOTE: If any servicing of the connecting rods, center bearings, or water pump drive gear is necessary, Arctic Cat recommends the crankshaft be taken to a qualified crankshaft rebuild shop for that service.

- Wash the crankshaft with bearings in parts-cleaning solvent.
- Inspect the bearings for wear, scoring, scuffing, damage, or discoloration. Rotate the bearings. Bearings must rotate freely and must not bind or feel rough. If any abnormal condition is noted, replace the bearing.

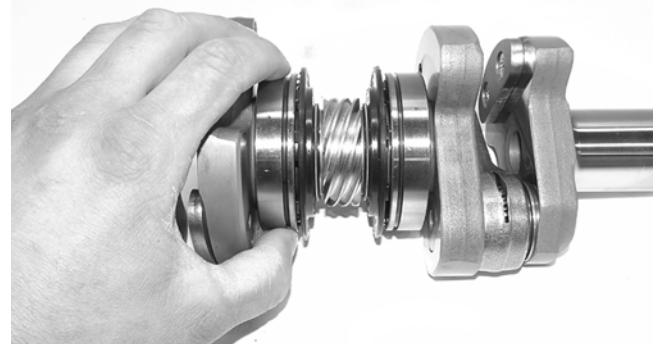

CWI-060

- Inspect the connecting-rod bearings by rotating them. The bearings must rotate freely and must not bind or feel rough. If a connecting-rod bearing must be replaced, the connecting rod and crank pin must also be replaced.



CWI-058

4. Visually inspect the springs to make sure they are in proper location on the seals.

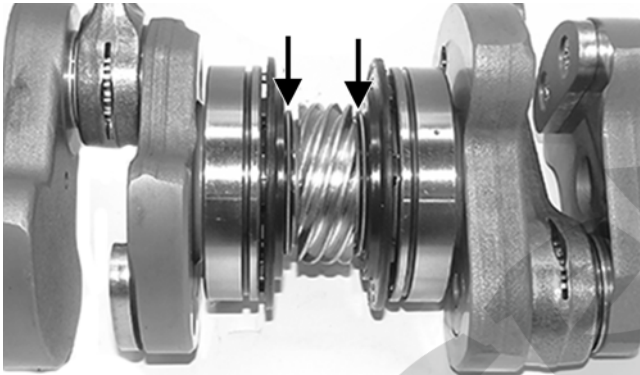

CWI-083A

5. Inspect the water pump drive gear for any signs of worn or chipped teeth. If either condition exists, replace the gear.

■NOTE: Lubricate bearings thoroughly prior to assembly.

REMOVING/INSTALLING OUTER CRANKSHAFT BEARINGS

■NOTE: The end bearings are not pressed onto the crankshaft. The bearings can be removed simply by sliding them off the crankshaft.

Inspect the crankshaft bearing area for wear. If any wear is noted on either end, replace the crankshaft end.

■NOTE: Install the bearings by sliding each bearing onto the crankshaft making sure the retaining pin hole (A) in the outer race of the bearing is properly positioned and will align with the retaining pin (B) in the crankcase.

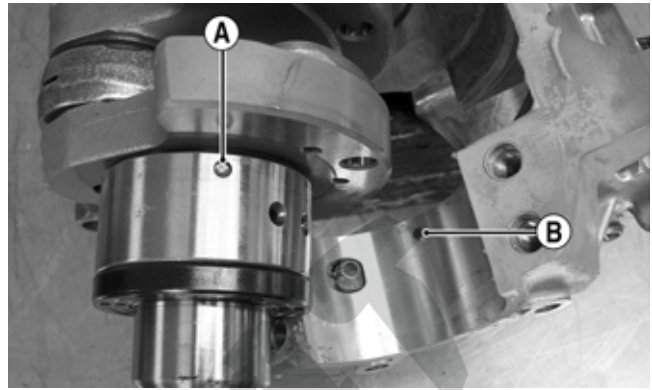

IO019B

REED VALVE ASSEMBLY

1. Carefully pry the reed assemblies from the intake manifold and inspect the reed valves for cracks or any deterioration; then remove the screws securing the reeds.



CWI-084

2. To assemble, place the reed retaining plate (with the lip facing outward) into position and secure with the screws tightened to 8.5 in.-lb.

■NOTE: When installing the outer reed valves, be sure the clipped edge matches the clipped edge of the reed retaining plate.

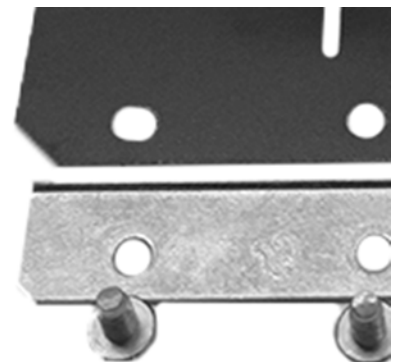

CWI-110

3. Install the reed valve assemblies into the intake manifold by installing the top and bottom sides of the reeds first; then press down making sure the reeds are installed flush with the intake manifold.



CWI-055



CWI-080

2. Position a bore gauge between the micrometer points and move it from top to bottom and side to side to find zero; then adjust the gauge to zero.



CWI-056



CWI-090

Measuring Critical Components

CYLINDER TRUENESS

1. Measure each cylinder in locations from front to back and side to side top and bottom of the cylinder for a total of four readings.

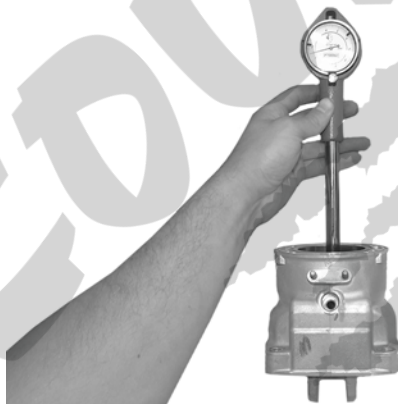

CWI-077

2. The trueness (out-of-roundness) is the difference between the highest and lowest reading. Maximum trueness (out-of-roundness) must not exceed 0.004 in.

PISTON SKIRT/CYLINDER CLEARANCE

1. Measure the piston skirt diameter 10 mm from the bottom of the piston (just below the slot). Once the measurement is final, lock the micrometer.



CWI-089

3. Place the bore gauge in the cylinder and measure each cylinder in locations from front to back and side to side top and bottom of the cylinder for a total of four readings. The difference (clearance) must be within 0.0031-0.0041 in.

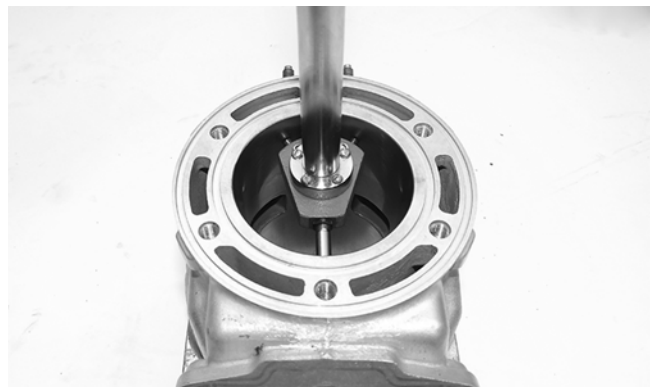

CWI-087

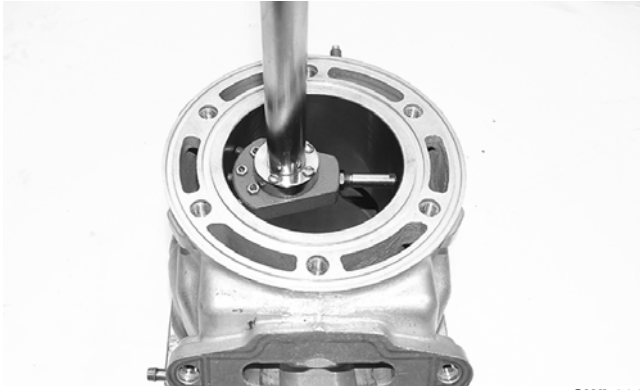

CWI-086

PISTON PIN

Measure the piston pin diameter at each end and in the center. Acceptable piston pin measurement must be within 0.8659-0.8661 in. If any measurement varies by more than 0.001 in., the piston pin and bearing must be replaced as a set.

- Measure A & B with Caliper or Height Gauge
- Measure C & D with Dial Indicator

Inspection Location	A	B	C	D
Specification	115.7 mm 4.555 in	59.5 mm 2.343 in	0.05 mm 0.002 in	0.05 mm 0.002 in
Tolerance Range	± 0.15 mm ± 0.006 in	± 0.15 mm ± 0.006 in	0-0.1 mm 0-0.004 in	0-0.2 mm 0-0.008 in

0747-810



CWI-079

CRANKSHAFT RUNOUT

1. Using the V Blocks, support the crankshaft on the surface plate.

■NOTE: The V blocks should support the crankshaft on the middle bearings.

2. Mount a dial indicator and base on the surface plate. Position the indicator contact point against the crankshaft location points C and D. Zero the indicator and rotate the crankshaft slowly. Note the amount of crankshaft runout (total indicator reading).

3. If runout exceeds 0.002 in. at any of the checkpoints, the crankshaft must be either straightened or replaced.

Assembling

■NOTE: The use of new gaskets and seals is recommended when assembling the engine.

■NOTE: Prior to assembling the engine, use parts cleaning solvent and compressed air and thoroughly clean the threaded holes of the crankcase and cylinders to properly tighten.

WARNING

Always wear safety glasses when drying components with compressed air.

■NOTE: When the use of a lubricant is indicated, use Arctic Cat C-Tec2 engine oil.

1. Apply a thin coat of grease to the inner seal lips of the water pump seal.
2. Using the seal driver, position the inner water pump shaft seal onto the seal driver and gently tap the seal down into position.

■NOTE: Grease must be applied to the lips of the inner seal before installation.

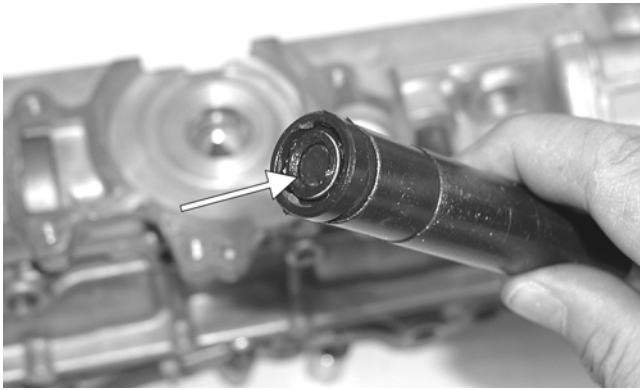

MS986A

■NOTE: The seal must be installed with its spring side towards the crankshaft.

3. Install the snap ring securing the inner seal in the crankcase.
4. Using the seal driver, carefully install the outer water pump seal. Gently tap the seal down into position until it seats itself against its flange.
5. Secure the upper crankcase half upside-down on a suitable support; then install the C-ring (A), the four bearing retaining pins (B), and the two crankcase dowel pins (C).

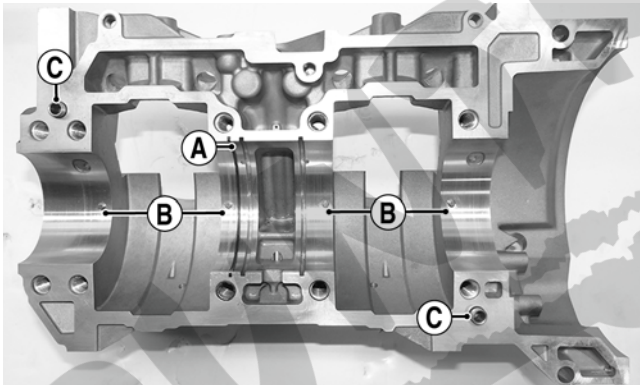

CWI-027A

6. Apply a thin coat of Loctite 5900 Sealant to the entire bottom half of the crankcase sealing surface.

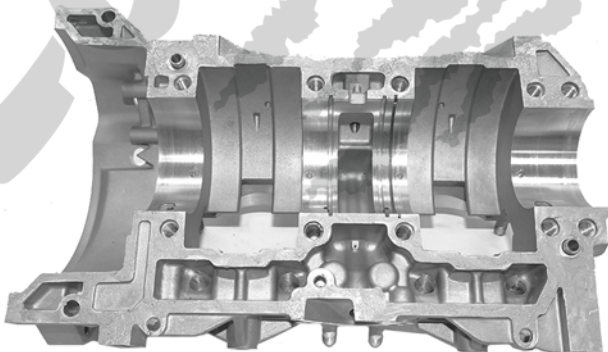

CWI-067

7. Place the crankshaft end bearings into position making sure the bearing retaining pin holes are positioned inward.

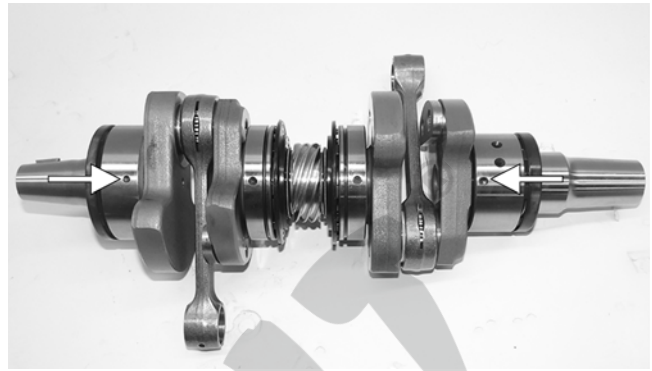

CWI-030A

8. Install the crankshaft into the upper crankcase half. Be sure the alignment hole in each bearing is positioned over its respective retaining pin in the crankcase; then seat the crankshaft.

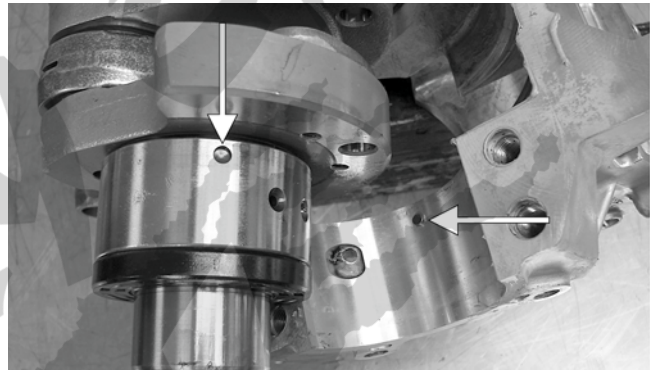

IO019A

■NOTE: To check the bearing for proper position, place the point of a sharp tool into the dimple found in the bearing race. Strike the tool with the palm of the hand in either direction. If the bearing moves, it isn't positioned correctly and must be rotated until it drops onto the retaining pin.

CAUTION

If the bearings are not properly seated during assembly, the crankcase halves will not seal tightly and severe engine damage will result.

9. Assemble the crankcase halves; then install the crankcase cap screws securing the crankcase halves.
10. Tighten cap screws (1-10) in two steps using the pattern shown. First tighten to 15 ft-lb; then tighten to 33 ft-lb.

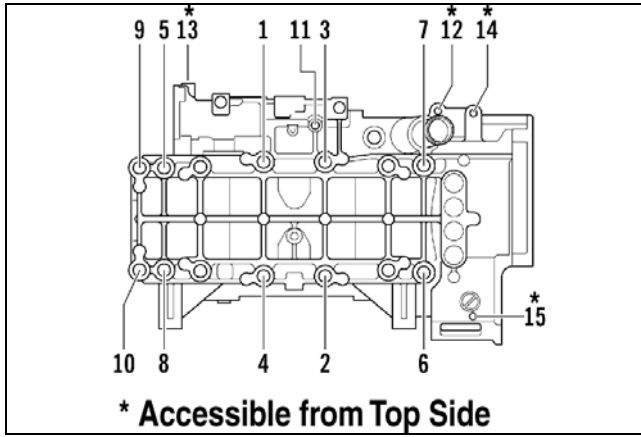

742-198A

11. Tighten screw 11 to 20 ft-lb; then turn the engine right-side up and tighten screws 12-15 in two steps to 102 in.-lb.
12. Apply a thin coat of grease to the sealing surface of the water pump shaft; then place the Oil Seal Protector Tool at the end of the shaft.

CAUTION

Be very careful not to damage the seals when installing the oil pump driveshaft. Twist the driveshaft clockwise as it enters the seal area and while pushing it through the seals.

13. Rotate the water pump shaft while carefully pushing it through the oil and water pump seals until the driveshaft and crankshaft gears engage; then remove the oil seal protector tool (A) from the end of the shaft.

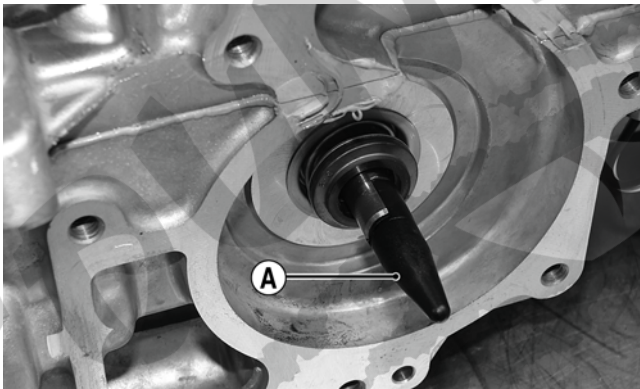

10025A

14. Place the impeller into position and secure with the cap screw (threads coated with blue Loctite #243) and washers. Be sure the rubber side of the washer is lubricated with a light coat of grease and directed toward the impeller. Tighten to 102 in.-lb.

CAUTION

The rubber side of the washer securing the impeller must be positioned toward the impeller. If installed incorrectly, a coolant leak will result and engine damage may occur.

15. Apply a thin film of low-temp grease to the water pump cover O-ring; then position the O-ring into the water pump cover. With the alignment pins in place, install the cover. Secure with the screws using a crisscross pattern. Tighten to 102 in.-lb.

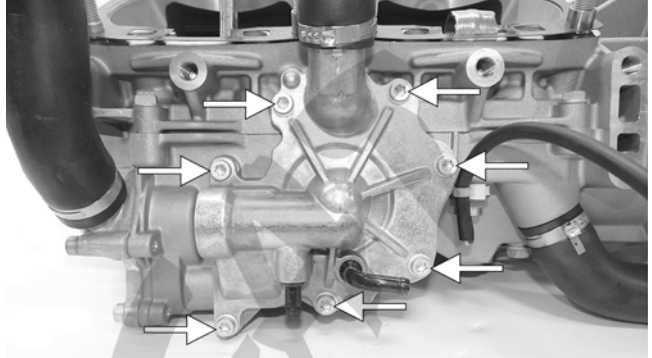

CWI-016A

16. Tip the crankcase assembly up on the water pump side; then pour Arctic Cat C-Tec2 engine oil into the center cavity of the crankshaft until the oil is level with the shoulder of the shaft (A).

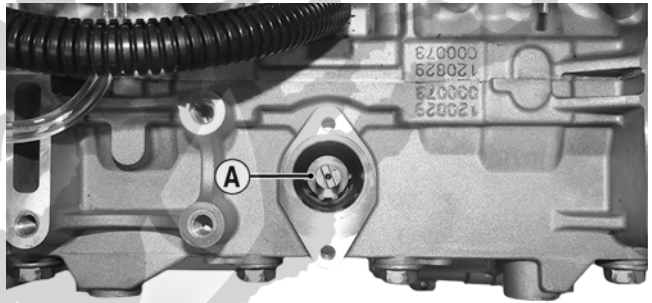

CWI-016A

CAUTION

Failure to fill the center cavity of the crankcase assembly will result in center gear damage and engine failure.

■NOTE: After the center cavity is filled with engine oil, be sure to install the hose with loom onto the upper crankcase half or engine oil will leak from that area.

17. Position the shim on the retainer end of the pump shaft; then install the retainer with a new O-ring. Tighten screws to 102 in.-lb.
18. Secure the reed valve assemblies and intake manifolds to the engine case using the existing screws. Tighten in two steps to 115 in.-lb in order from the letter A to the letter F (embossed on the manifold).

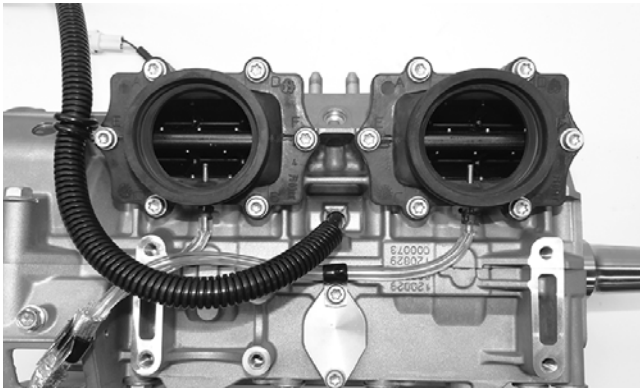

CWI-020

19. With the bypass/check valve of the thermostat directed to the 12 o'clock position, install the thermostat and housing; then in a crisscross pattern, tighten the screws to 102 in.-lb.

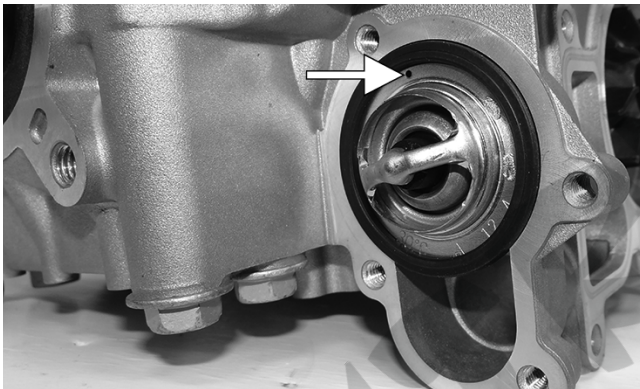

CWI-018A

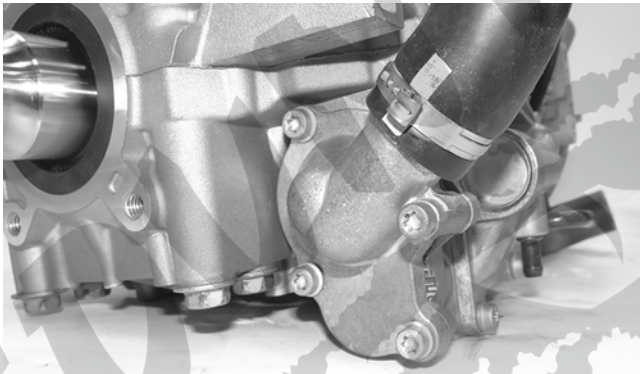

CWI-064

20. Install the dowel pins into the crankcase; then place the cylinder base gasket into position on the crankcase.
21. Install the piston rings on each piston so the letters KDN5 on the top (inclined surface) of each ring faces the dome of the piston.

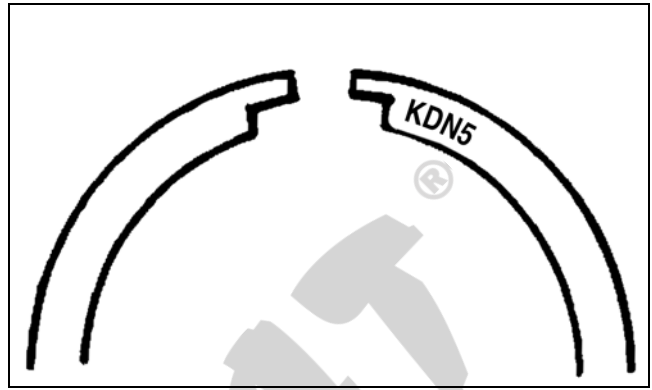

CWI-078A

CAUTION

Incorrect installation of the piston rings will result in engine damage.

22. Apply oil to the connecting-rod small end bearings; then install the small-end bearings.
23. Place each piston over the connecting rod so the indicator arrow on each piston will point toward the exhaust ports; then secure with an oiled piston pin.

■NOTE: The indicator arrow is found on the piston dome.

24. Install the new circlips so the open end is directed either up or down.

CAUTION

Make sure the circlips are firmly seated before continuing with assembly.

25. Rotate each piston ring until the ring ends are properly positioned on either side of the ring keeper; then apply oil to the piston assemblies and cylinder bores.



CWI-063

26. In turn on each cylinder, place a piston holder (or suitable substitute) beneath the piston skirt and square the piston in respect to the crankcase; then using a ring compressor or fingers, compress the rings and slide the cylinder over the piston. Remove the piston holder and seat the cylinder firmly onto the crankcase.

■NOTE: The cylinders should slide on easily. **DO NOT** force the pistons into the cylinders.

27. Install each cylinder with the eight existing nuts; then secure the cylinders by tightening the cylinder base nuts to 15 ft-lb then to 38 ft-lb in a crisscross pattern.
28. Install the cylinder O-rings (lightly coated with oil) on the top of each cylinder making sure they are correctly positioned in the grooves.

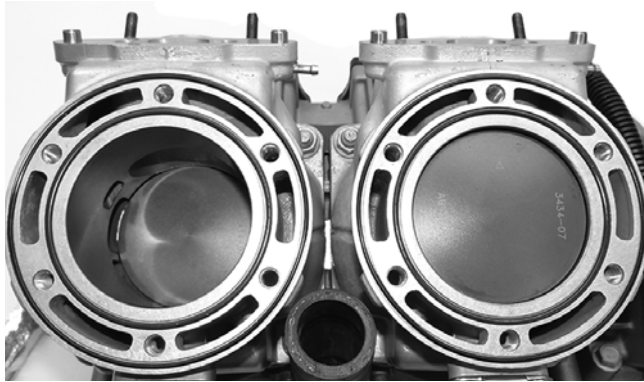

CWI-010

29. Place new O-rings (lightly coated with oil) onto each of the head cap screws. Place four of these cap screws (from opposite end of each other) into the cylinder head. Thread the spark plugs in part way; then while holding the head above the cylinder, carefully start and finger-tighten all four cap screws while observing the cylinder O-rings to make sure they remain in position. Slowly place the head into position on top of the O-rings.

■NOTE: To install the remaining cap screws, the spark plugs must be removed.

30. Start and finger-tighten the cap screws being very careful not to move the cylinder head; then tighten the cap screws in two steps to 13 ft-lb then 28 ft-lb using the pattern shown.

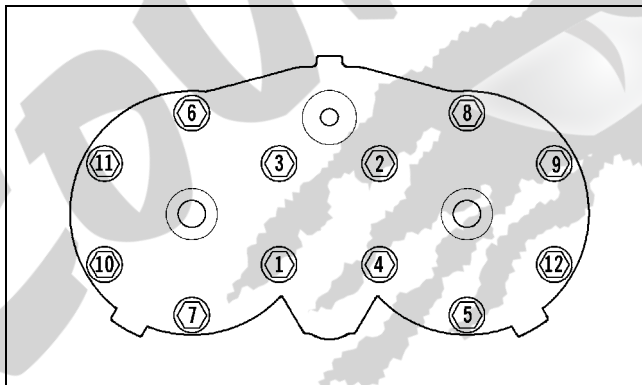

0747-890

■NOTE: At this point, install the spark plugs; then install the knock sensor. Tighten the sensor to 18 ft-lb.

31. Install the coolant inlet hose to the cylinder head and water pump; then secure using the clamp.
32. Install the fuel rail assembly into the back of the cylinders making sure the gaskets are in place; then secure the rail using new nylon nuts. Tighten to 102 in.-lb.



CWI-008

■NOTE: At this time if the coolant temperature sensor was removed, install the sensor (threads coated with blue Loctite #243) and tighten to 18 ft-lb.

■NOTE: At this point, pressure test the engine (see the Engine-Related Items section).

33. With the raised edge of the valve aligned with the channel of the cylinder, slide the APV assemblies into position in the cylinders; then secure with cap screws. Tighten to 102 in.-lb.

■NOTE: The APV gaskets will align with the contour of the cylinder and APV assemblies when installed correctly. Be sure valves move freely after installing by pulling on the valve cable.



CWI-073

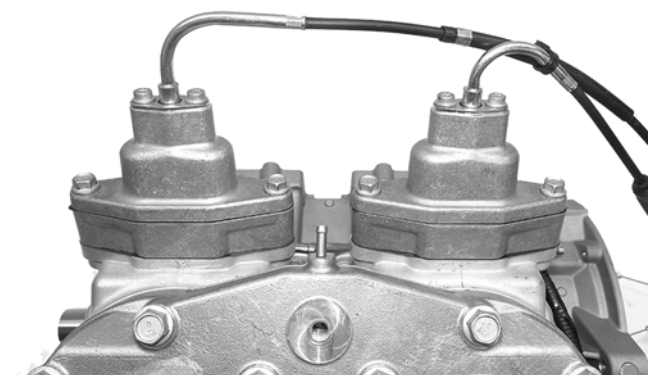

CWI-068

34. Secure the stator plate to the crankcase with the screws (coated with blue Loctite #243) and tightened to 102 in.-lb.

35. Route the stator harness through the opening in the crankcase; then secure the stator to the stator plate with the screws (coated with blue Loctite #243). Tighten to 10 ft-lb.
36. Secure the upper ignition timing sensor with cap screws (coated with blue Loctite #243). Tighten to 80 in.-lb; then install the wiring grommet into the notch of the crankcase.
37. Secure the lower ignition timing sensor and bracket with two screws (coated with blue Loctite #243). Tighten to 80 in.-lb; then install the grommet. With the stator harness properly positioned, install the plate and cap screw (coated with blue Loctite #243). Tighten to 80 in.-lb.

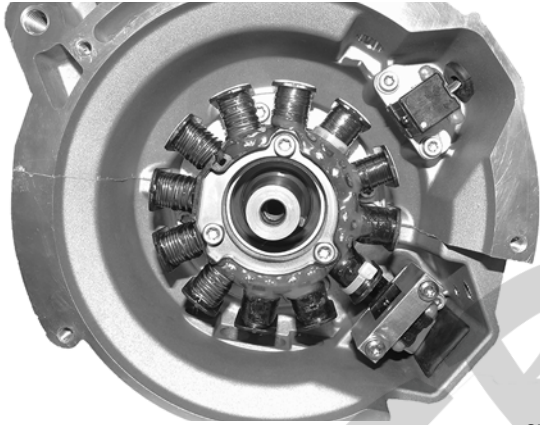

CWI-074

38. Install the key in the crankshaft (if removed).

■ **NOTE:** Before installing the flywheel, be sure to wipe the crankshaft and flywheel tapers clean using a clean, lint-free towel.

39. Place the recoil cup in position on the flywheel and visually center; then secure the cup with three cap screws and tighten only until snug. While holding the cup, slide the flywheel onto the crankshaft making sure the keyways match.
40. Apply red Loctite #271 to the threads of the flywheel cap screw with the large flat washer; then finger-tighten only at this time into the crankshaft.
41. Secure the recoil cup while using the spanner wrench and tighten the three cap screws (from step 39) evenly to 18 ft-lb.
42. Using the spanner wrench, tighten the flywheel cap screw (from step 40) to 50 ft-lb.

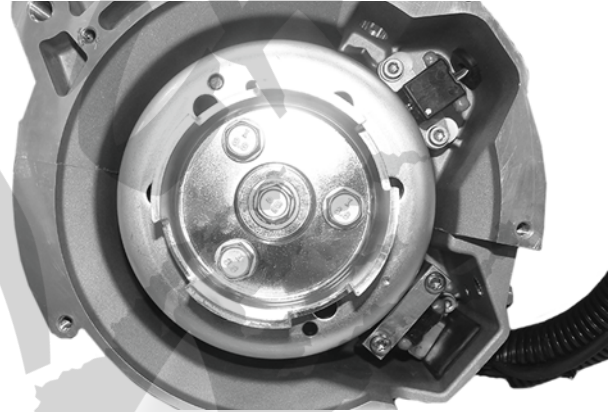

CWI-070

43. Install the exhaust manifold with new gaskets and secure with the eight nuts. Tighten the nuts in a criss-cross pattern to 12 ft-lb.
44. If the knock sensor was removed, secure it to the cylinder head using the existing cap screw. Tighten to 18 ft-lb.
45. After installing the engine, bleed the oil lines using the Oil Bleeding Procedure included with the CATT II Tool.

Engine Servicing - 8000

This engine sub-section has been organized to show a progression for servicing of the Arctic Cat 8000 engine. For consistency purposes, this sub-section shows a complete and thorough progression; however, for efficiency it may be preferable to disassemble only those components needing to be addressed. Also, some components may vary from model to model. The technician should use discretion and sound judgment.

SPECIAL TOOLS

A number of special tools must be available to the technician when performing service procedures in this engine section.

Description	p/n
Ball Hone	0644-294
Flywheel Spanner Wrench	0144-007
Flywheel Puller	0744-040
Flywheel Puller Insert	0644-568
Extractor Nut (Medium)	0643-074
Oil Seal Protector Tool	0644-219
Piston Pin Puller	0644-328
Surface Plate	0644-016
Water Pump Bearing and Seal Tool Kit	0644-557
V Blocks	0644-535
Vacuum Test Pump	0644-131

■NOTE: Special tools are available from the Arctic Cat Service Parts Department.

Disassembling

■NOTE: When disassembling top-side components, mark MAG-side and PTO-side components for assembling purposes.

1. Using the Flywheel Spanner Wrench to secure the flywheel, remove the flywheel cap screw and washer; then remove the three starter clutch cap screws and remove the clutch.

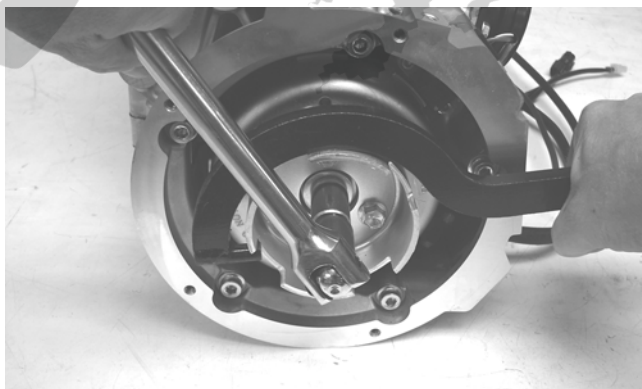

CM138

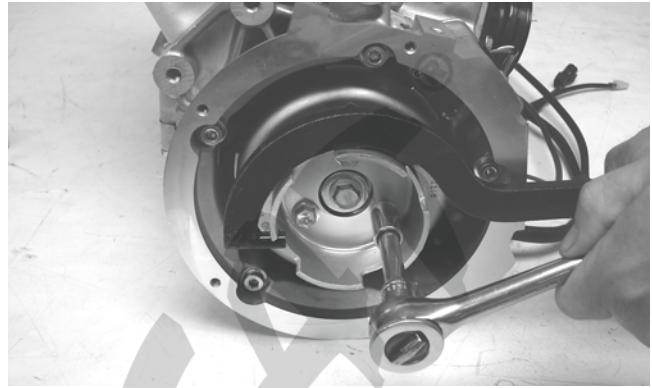

CM139

2. Install the Flywheel Puller Insert onto the end of the crankshaft.



IO013

3. Using Flywheel Puller or suitable substitute, remove the flywheel from the crankshaft by tightening the puller bolt, striking the head of the puller bolt with a hammer, and tightening again. Repeat this procedure until the flywheel is free. Account for the key.

CAUTION

To prevent damage to the crankshaft, do not thread puller bolts more than 1/2 in. into the flywheel. Damage to the coils may result.

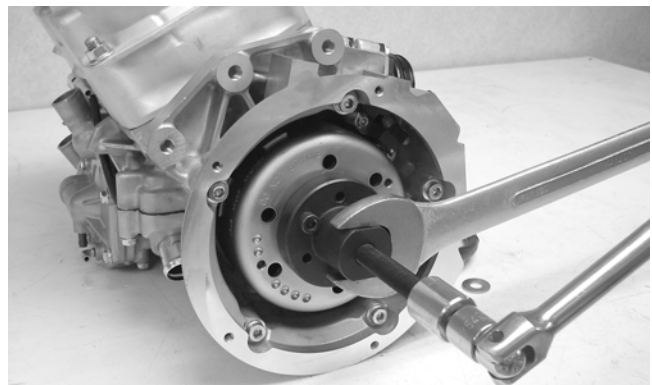

CM140

■NOTE: To ensure the cleanliness of the flywheel magnets, place the flywheel (with the magnets facing upward) on a clean bench.

- Remove the cap screw securing the ground wire to the crankcase.

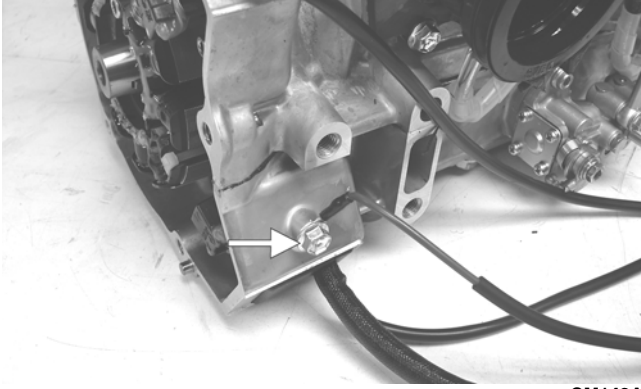

CM142A

- Remove the Allen-head cap screw (A) securing the stator lead wire plate to the crankcase; then remove the Allen-head cap screws (B) securing the timing sensors, remove the sensors, and account for the harness grommets.

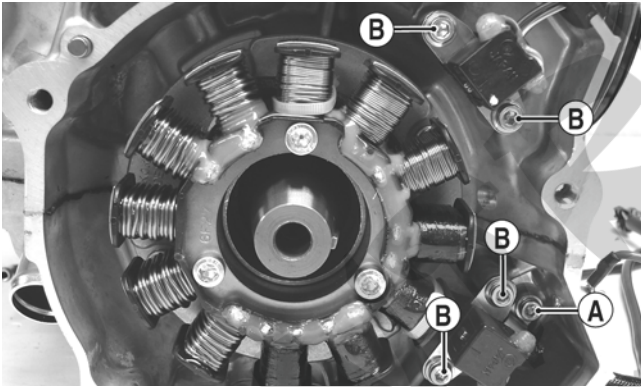

CM141C

- Remove the Allen-head cap screws securing the stator to the stator plate. Route the stator lead wire out of the crankcase; then remove the stator assembly.

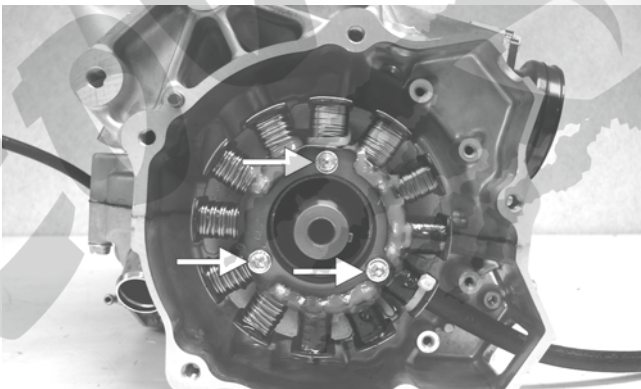

CM143A

- Remove the cap screws securing the stator plate to the engine; then remove the plate.

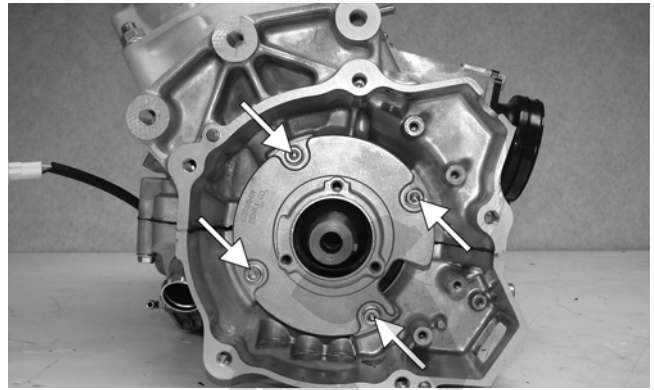

CM145D

- NOTE: For assembling purposes, note the indentation (A) of the stator plate is aligned with the harness opening (B) in the crankcase.

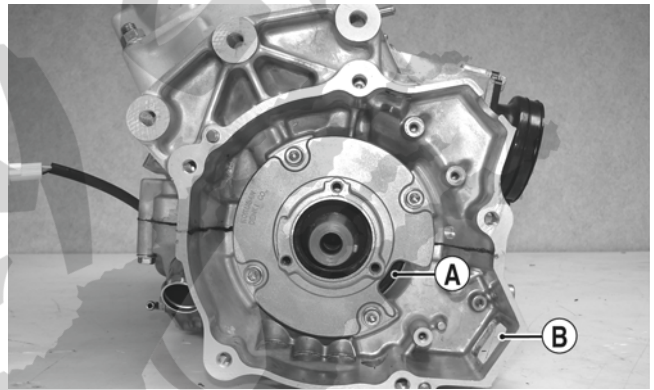

CM145C

- NOTE: The stator plate screws had Loctite applied to the threads during assembly. Using an impact driver, apply a sharp blow to the head of each screw to break the Loctite loose before removal.

- Remove the cap screws securing the APV assemblies to the cylinders; then remove the APV assemblies and set them aside.

- NOTE: For assembling purposes, note that the APV exhaust valves and gaskets are directional and marked (M) for magneto cylinder and (P) for PTO cylinder.

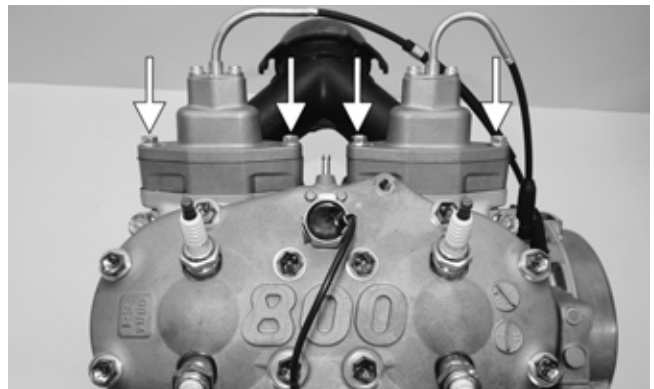

XM024A

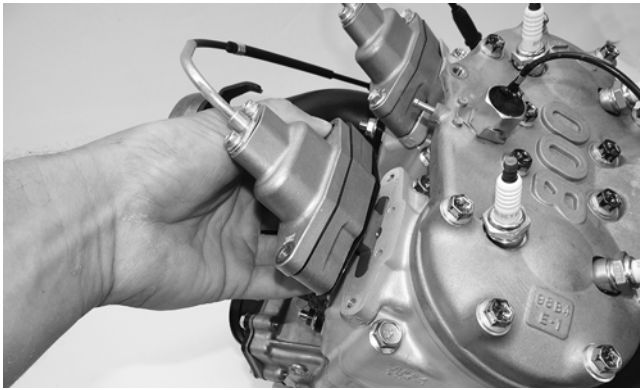

XM017

9. Remove the spark plugs.

■NOTE: At this point, remove the knock sensor and lock plate from the cylinder head by bending the lock plate tabs down and unthreading the sensor.

10. Remove the cap screws with O-rings securing the cylinder head; then separate from the cylinders. Account for the O-rings.

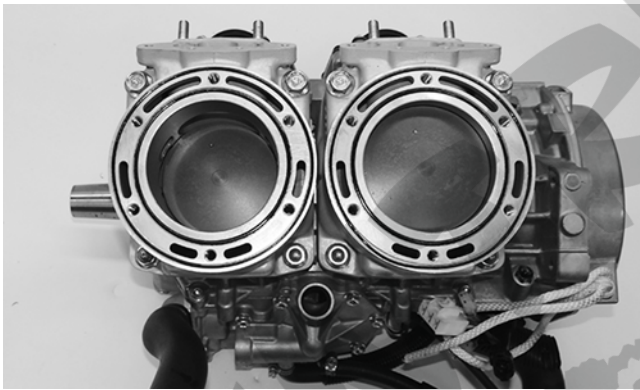

XM022

■NOTE: When removing the cylinders, place the engine on its intake flanges on a drain tray to allow residual coolant to drain from the cylinder/crankcase water jacket.

11. Remove the four nuts and four cap screws securing the cylinders to the crankcase; then using a soft hammer, gently tap the cylinders and remove from the crankcase by lifting them straight up off their studs. Account for gasket(s) and alignment pins.

CAUTION

When removing a cylinder, be sure to support the piston to prevent damage to the crankcase and piston.

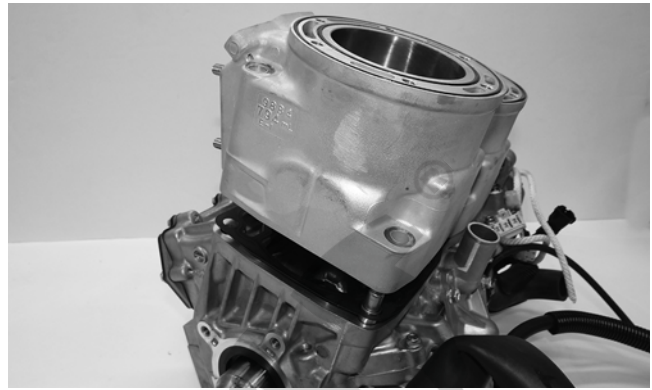

XM018

12. Remove the PTO-side piston-pin circlip from the PTO-side piston; then remove the MAG-side piston-pin circlip from the MAG-side piston.



XM020A

13. Using Piston Pin Puller and medium Extractor Nut, remove the piston pins from both pistons.

■NOTE: For proper assembly, keep all MAG-side components and all PTO-side components separated. Assemble them on their proper sides.

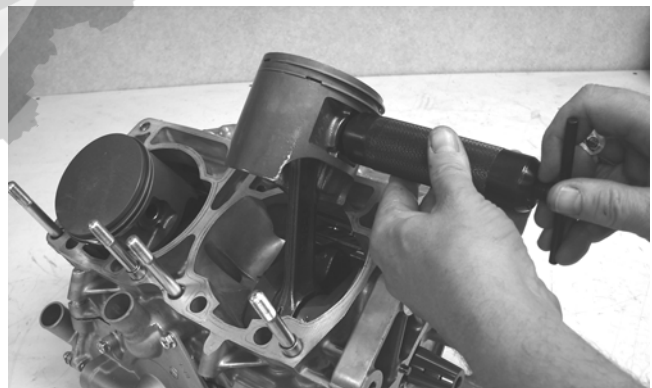

CM150

CAUTION

DO NOT use any type of punch to drive the piston pin free of the piston; damage may result. Use a piston-pin puller only.

14. Lift the pistons clear of the connecting rods and remove the small-end connecting-rod bearings (account for two washers); then remove the piston rings. Keep each piston with its rings; keep each piston pin and bearing together as a set.

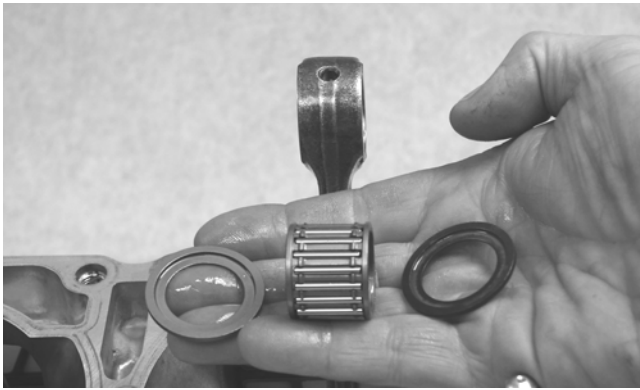

CM151

■NOTE: Place a suitable length of rubber hose around the connecting rods to prevent the connecting rods from damaging the crankcase.

15. Disconnect the intake flange oil lines from the oil pump; then remove the cap screws securing the intake flanges. Remove the intake flanges and reed valve assemblies.

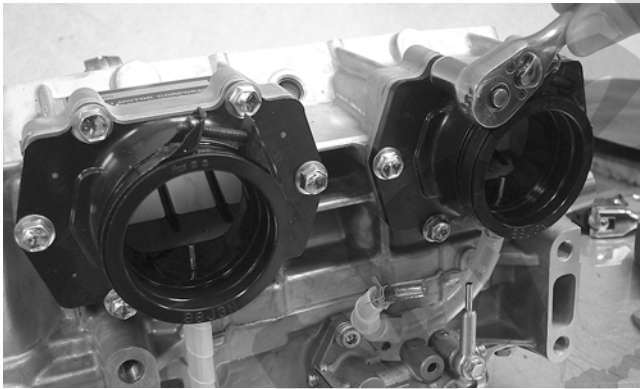

IO014

16. Remove the lower union cap screw securing the lower check valve assembly to the crankcase; then remove the two screws securing the oil-injection pump to the crankcase. Remove the pump, retainer, and O-ring and account for the two gaskets from the lower union.

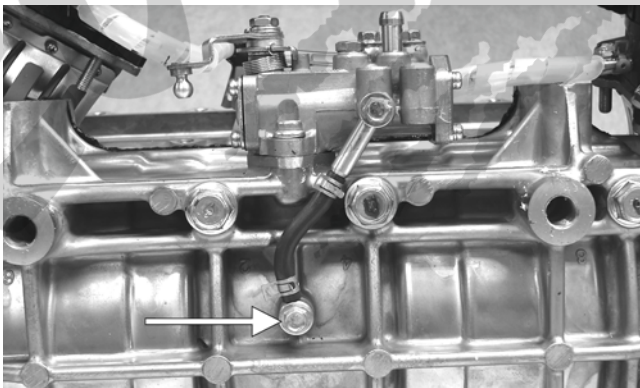

CM153A

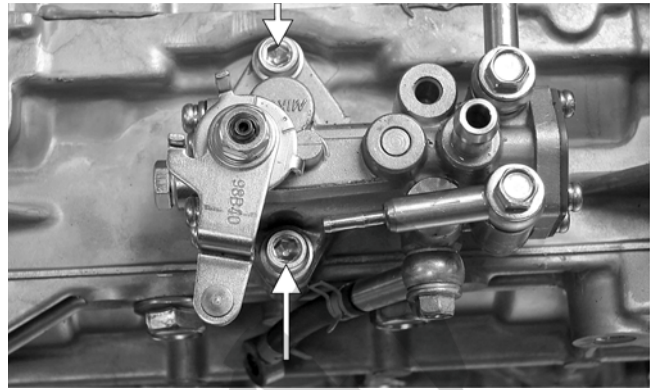

IO015A

17. Remove the four cap screws securing the thermostat cap; then remove the cap, gasket, and thermostat.

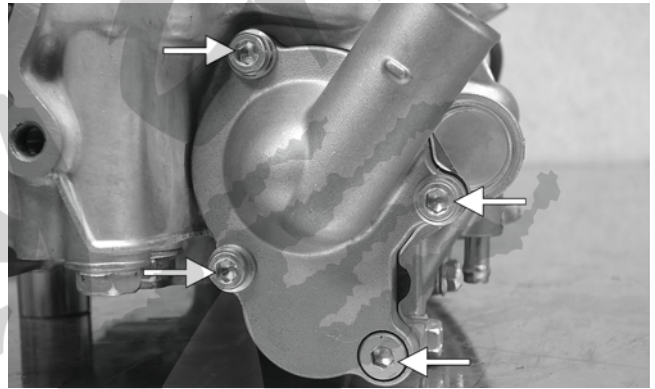

IO017A

■NOTE: For assembling purposes, note that the positioning of the bypass/check valve is directed up.

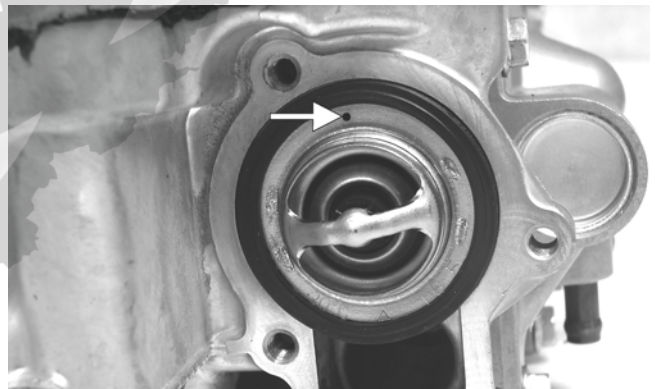

CM157A

18. Remove the seven screws securing the water pump cover to the crankcase and remove the cover. Account for the O-ring gasket and the alignment pins.

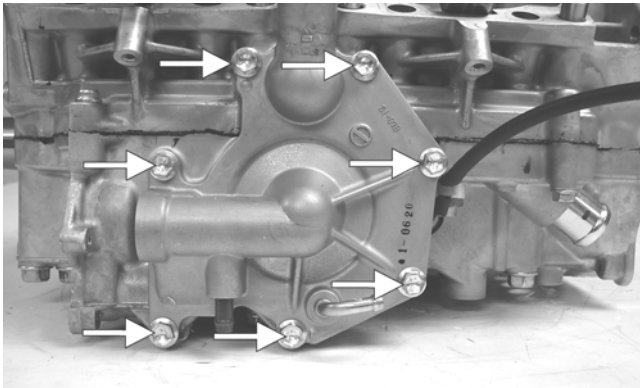

CM156A

- Remove the cap screw securing the water pump impeller; then slide the impeller free of the shaft. Account for the washer and gasket.

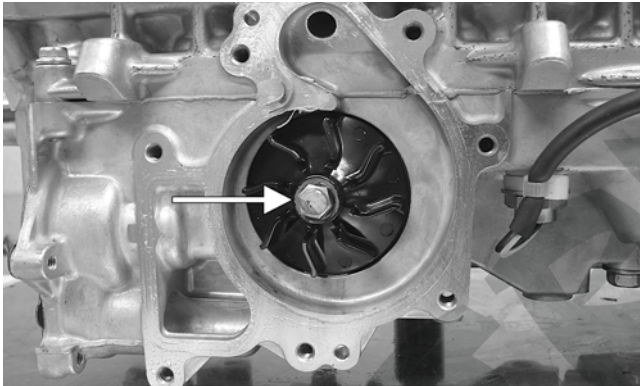

IO018A

- Prior to turning the engine upside down, remove the two crankcase cap screws (A) from the water pump side of the engine; then remove the two cap screws (B) from the magneto housing.

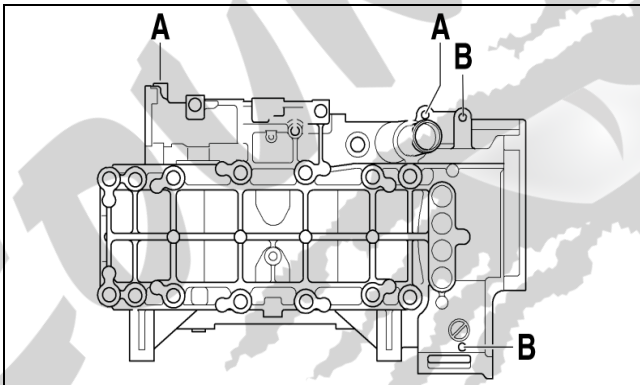

742-198B

- Turn the engine upside down on support blocks, cut the cable tie, and remove the coolant temperature sensor switch.
- With its bottom side up on two support blocks, remove the cap screws securing the crankcase halves.
- Separate the crankcase halves by installing two crankcase cap screws in opposite corners leaving the heads approximately 1/4 in. out. Using a plastic hammer and lifting on the ends of the crankshaft, tap on each cap screw head until the case halves separate. Remove the cap screws.

CAUTION

DO NOT drive any tool between halves to separate the crankcase. Damage to the sealing surfaces will result.

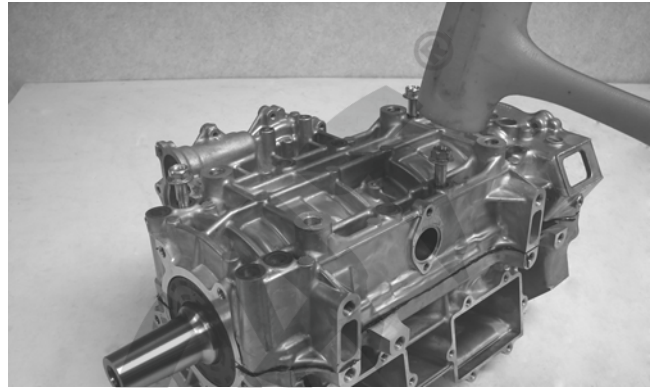

CM158

- Lift the bottom half of the crankcase off the top half.

CAUTION

Care must be taken to not allow the connecting rods to drop onto the sealing surface of the bottom case half.

- Lift the crankshaft free from the top half of the crankcase and slide the crankshaft oil seals off the crankshaft. Account for the C-ring (A). Remove the bearing retaining pins (B) and account for the crankcase dowel pins (C).

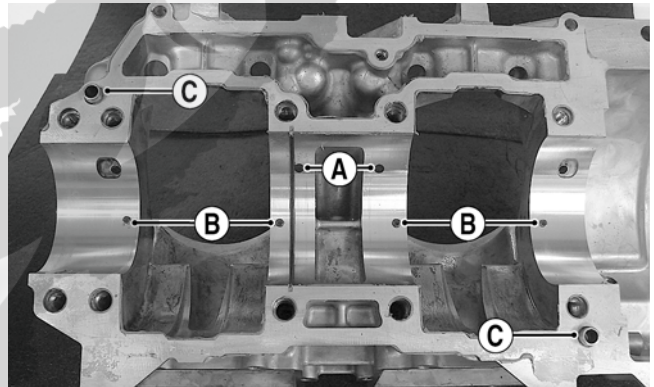

IO023A

NOTE: The end bearings are not pressed onto the crankshaft. After removing the seals, use care not to allow the bearings to slide off the crankshaft.

- Remove the oil-injection pump/water pump drive-shaft from the lower crankcase half. Account for the thrust washer on the outer end of the shaft.

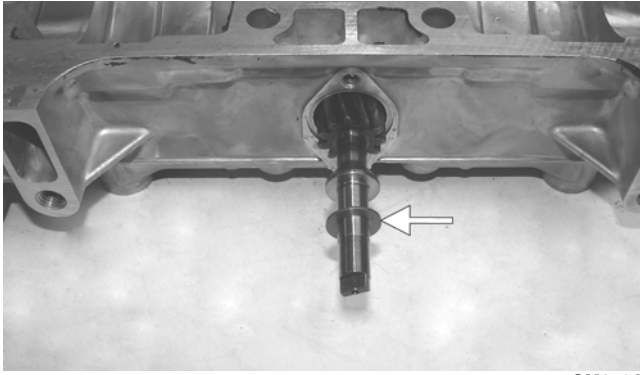

CM159A

■NOTE: When replacing the inner water pump seals, use the recommended Water Pump Bearing and Seal Tool Kit only.

27. Place the crankcase on the bench with the water pump side down. Using the long seal driver, drive the mechanical water pump seal from the crankcase.



FC036

28. Using a pair of snap ring pliers, remove the snap ring securing the inner seal in the crankcase.
29. Using the hooked end of the tool, pull the inner seal free of the crankcase.
30. Using the hooked end of the tool, pry the seal ring from the backside of the water pump impeller.

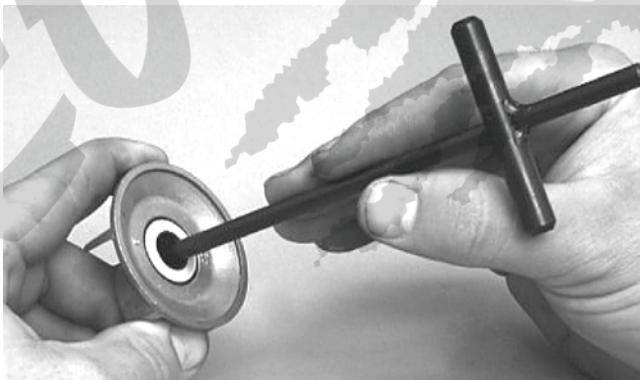

AN327D

Cleaning and Inspecting

CYLINDER HEAD

1. Using a non-metallic carbon removal tool, remove any carbon buildup from the combustion chambers being careful not to nick, scrape, or damage the combustion chambers or the sealing surfaces.
2. Inspect the spark-plug holes for any damaged threads.

■NOTE: If warpage is suspected, have a qualified machine shop inspect and repair if necessary.

3. Place the cylinder head on a Surface Plate covered with #400 grit wet-or-dry sandpaper. Using light pressure, move each cylinder head in a figure eight motion. Inspect the sealing surface for any indication of high spots. A high spot can be noted by a bright metallic finish. Correct any high spots before assembly by continuing to move the cylinder head in a figure eight motion until a uniform bright metallic finish is attained.

CAUTION

Water or parts-cleaning solvent must be used in conjunction with the wet-or-dry sandpaper or damage to the sealing surface may result.

CYLINDERS

1. Using a non-metallic carbon removal tool, remove carbon buildup from the exhaust ports.
2. Wash the cylinders in parts-cleaning solvent.
3. Inspect the cylinders for pitting, scoring, scuffing, and corrosion. If marks are found, repair the surface with the Ball Hone and honing oil.

■NOTE: To produce the proper 45° crosshatch pattern, maintain a low drill RPM. If honing oil is not available, use a lightweight, petroleum-based oil. Thoroughly clean the cylinders after honing using detergent soap and hot water and dry with compressed air; then immediately apply oil to the cylinder bores. If a bore is severely damaged or gouged, the cylinder must be replaced.

4. Place the head surface of each cylinder on the surface plate covered with #400 grit wet-or-dry sandpaper. Using light pressure, move each cylinder in a figure eight motion. Inspect the surface for any indication of high spots. A high spot can be noted by a bright metallic finish. Correct any high spots before assembly by continuing to move the cylinder in a figure eight motion until a uniform bright metallic finish is attained.

CAUTION

Water or parts-cleaning solvent must be used in conjunction with the wet-or-dry sandpaper or damage to the sealing surface may result.

PISTON ASSEMBLY

1. Using a non-metallic carbon removal tool, remove the carbon buildup from the dome of each piston.
2. Snap an old piston ring into two pieces; then grind the end of the old ring to a 45° angle and to a sharp edge. Using the sharpened ring as a tool, clean carbon from the ring-grooves. Be sure to position the ring with its tapered side up.

CAUTION

Improper cleaning of the ring-grooves by the use of the wrong type of ring-groove cleaner will result in severe damage to the piston.

3. Inspect each piston for cracks in the piston pin and skirt areas.
4. Inspect each piston for seizure marks or scuffing. Repair with #400 grit wet-or-dry sandpaper and water or honing oil.

■NOTE: If scuffing or seizure marks are too deep to correct with the sandpaper, it will be necessary to replace the piston.

5. Inspect the perimeter of each piston for signs of excessive “blowby.” Excessive “blowby” indicates worn piston rings or an out-of-round cylinder.

■NOTE: If synthetic oil is being used, a certain amount of “blowby” may be visible under normal use.

CRANKCASE

1. Wash the crankcase halves in parts-cleaning solvent.

■NOTE: Before washing the crankcase halves, make sure the four bearing dowel pins have been removed and accounted for.

2. Inspect the crankcase halves for scoring, pitting, scuffing, or any imperfections in the casting.
3. Inspect all threaded areas for damaged or stripped threads.
4. Inspect the bearing areas for cracks or excessive bearing movement. If evidence of excessive bearing movement is noted, the crankcase must be replaced.
5. Inspect the bearing dowel pins for wear.
6. Inspect the sealing surfaces of the crankcase halves for trueness by placing each crankcase half on the surface plate covered with #400 grit wet-or-dry sandpaper. Using light pressure, move each half in a figure eight motion. Inspect the sealing surfaces for any indication of high spots. A high spot can be noted by a bright metallic finish. Correct any high spots by continuing to move the half in a figure eight motion until a uniform bright metallic finish is attained.

■NOTE: Care must be taken not to remove an excessive amount of aluminum, or the crankcase must be replaced. If excessive aluminum is removed, too much pre-load will be exerted on the crankshaft bearings when assembled.

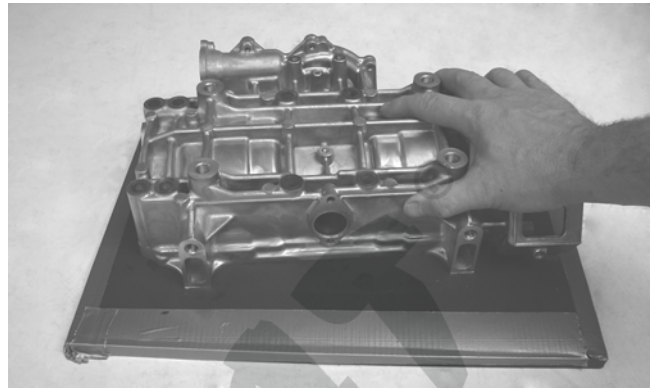

CM160

CAUTION

Water or parts-cleaning solvent must be used in conjunction with the wet-or-dry sandpaper or damage to the sealing surface may result.

CRANKSHAFT

■NOTE: If any servicing of the connecting rods, center bearings, or oil-injection pump drive gear is necessary, Arctic Cat recommends the crankshaft be taken to a qualified machine shop for that service.

1. Wash the crankshaft with bearings in parts-cleaning solvent.
2. Inspect the bearings for wear, scoring, scuffing, damage, or discoloration. Rotate the bearings. Bearings must rotate freely and must not bind or feel rough. If any abnormal condition is noted, replace the bearing.

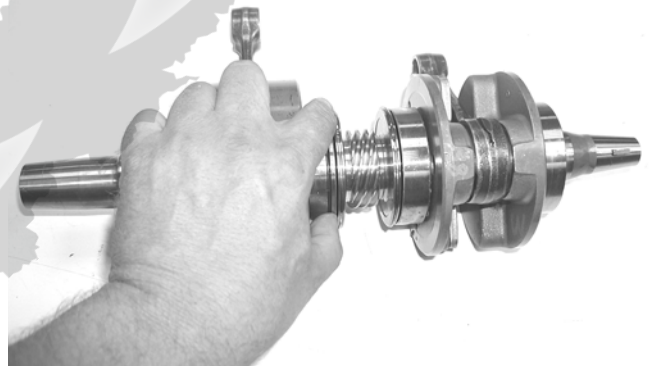

FC039

3. Inspect the connecting-rod bearings by rotating them. The bearings must rotate freely and must not bind or feel rough. If a connecting-rod bearing must be replaced, the connecting rod and crank pin must also be replaced.

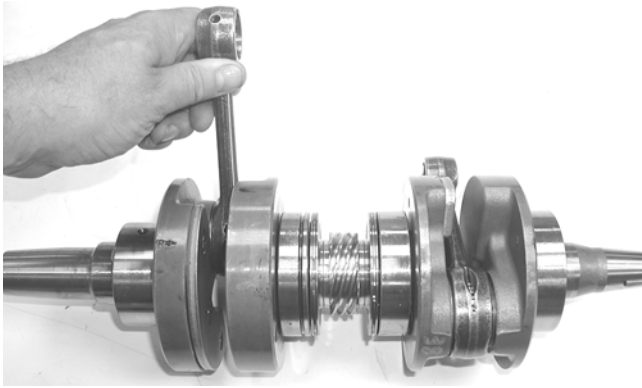

FC040

4. Inspect the oil-injection pump drive gear for any signs of worn or chipped teeth. If either condition exists, replace the gear.

■NOTE: Lubricate bearings thoroughly prior to assembly.

REMOVING/INSTALLING OUTER CRANKSHAFT BEARINGS

■NOTE: The end bearings are not pressed onto the crankshaft. The bearings can be removed simply by sliding them off the crankshaft.

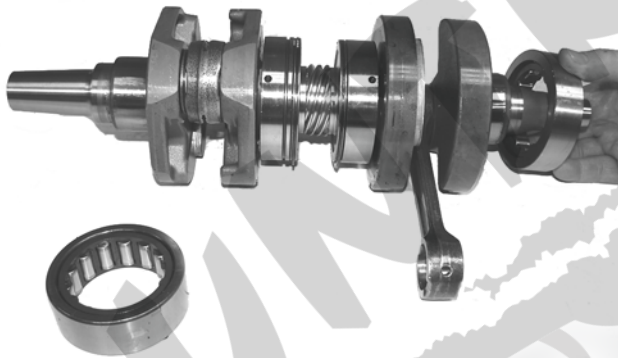

CM161

Inspect the crankshaft bearing area for wear. If any wear is noted on either end, replace the crankshaft end.

■NOTE: Install the bearings by sliding each bearing onto the crankshaft making sure the retaining pin hole (A) in the outer race of the bearing is properly positioned and will align with the retaining pin (B) in the crankcase.

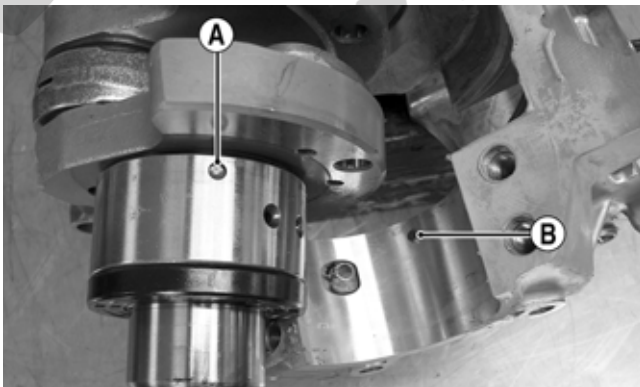

IO019B

REED VALVE ASSEMBLY

1. Inspect the reed valves, stoppers, and valve blocks for cracks or any deterioration.



XM227

2. Wash the reed valves, stopper, and cage assembly in parts-cleaning solvent and blow dry.

3. Inspect the reed stopper height. Using a caliper, measure the distance from the seat to the bottom outer tip edge of the stopper. Measurement must not exceed specifications. If measurement is not within specifications, either bend or replace the reed stopper.

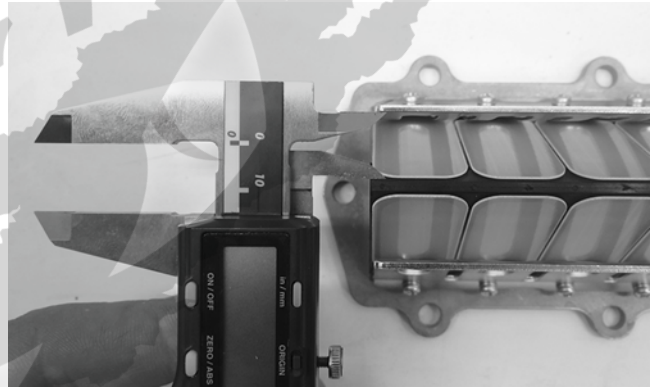

XM226

4. Inspect the reed-to-seat clearance. Using a feeler gauge, measure the clearance. Clearance must be less than 0.008 in. If clearance is not within specifications, replace the reed valve.

5. To assemble, place the reed valves on the cage with its clipped corner positioned to the lower right hand corner of the cage. Place the reed stopper assembly into position and secure with the screws tightened to 8.5 in.-lb.

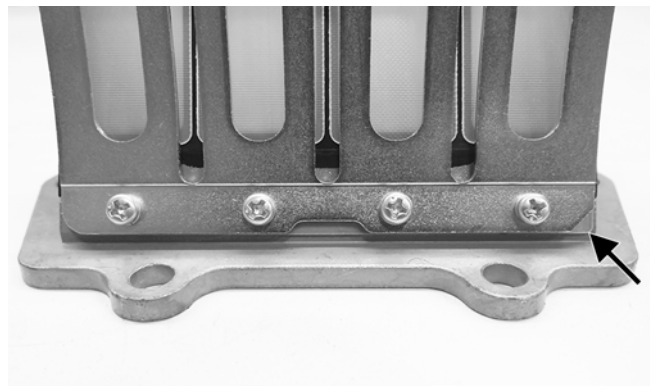

XM228A

Measuring Critical Components

CYLINDER TRUENESS

1. Measure each cylinder in locations from front to back and side to side top and bottom of the cylinder for a total of four readings.



CWI-077

2. The trueness (out-of-roundness) is the difference between the highest and lowest reading. Maximum trueness (out-of-roundness) must not exceed 0.004 in.

PISTON SKIRT/CYLINDER CLEARANCE

1. Measure the piston skirt diameter 10 mm from the bottom of the piston. Once the measurement is final, lock the micrometer.
2. Position a bore gauge between the micrometer points and move it from top to bottom and side to side to find zero; then adjust the gauge to zero.

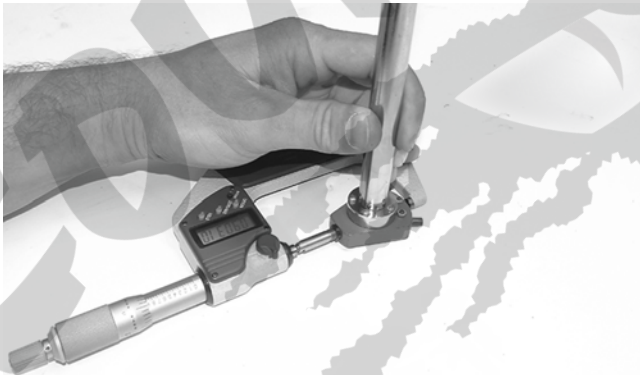

CWI-090



CWI-089

3. Place the bore gauge in the cylinder and measure each cylinder in locations from front to back and side to side top and bottom of the cylinder for a total of four readings. The difference (clearance) must be within 0.0031-0.0041 in.

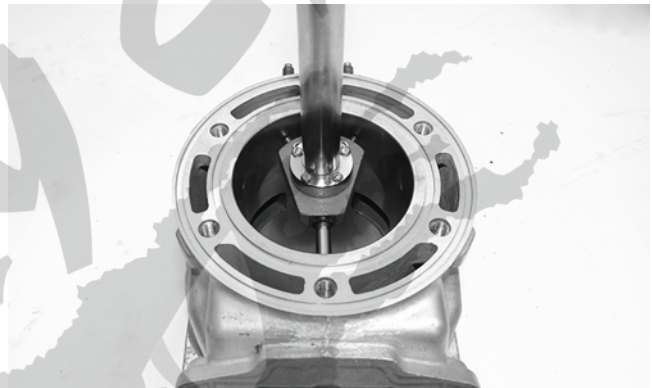

CWI-087

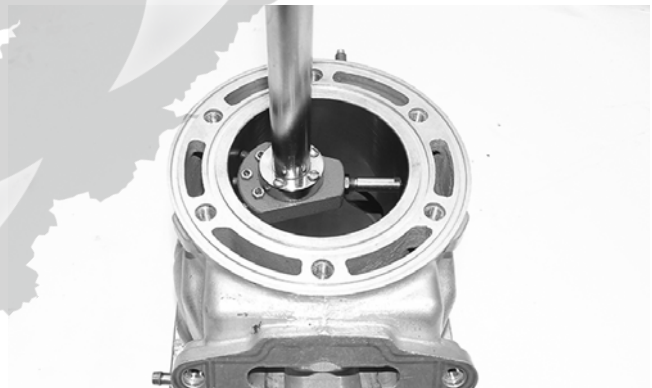

CWI-086

PISTON PIN

Measure the piston pin diameter at each end and in the center. Acceptable piston pin measurement must be within 0.8659-0.8661 in. If any measurement varies by more than 0.001 in., the piston pin and bearing must be replaced as a set.



CWI-079

CRANKSHAFT RUNOUT

1. Using the V Blocks, support the crankshaft on the surface plate.

■NOTE: The V blocks should support the crankshaft on the outer bearings.

2. Mount a dial indicator and base on the surface plate. Position the indicator contact point against the crankshaft location point A (PTO-end) from the crankshaft end. Zero the indicator and rotate the crankshaft slowly. Note the amount of crankshaft runout (total indicator reading).

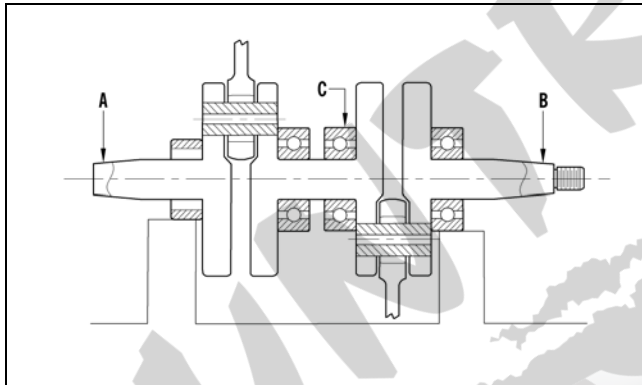

0742-727

■NOTE: For runout location point specifications, see Crankshaft Runout/Repair Specifications in the General Information section of this manual.

3. Position the indicator contact point against the crankshaft location point B (MAG-end) from the crankshaft end. Zero the indicator and rotate the crankshaft slowly. Note the amount of crankshaft runout (total indicator reading).

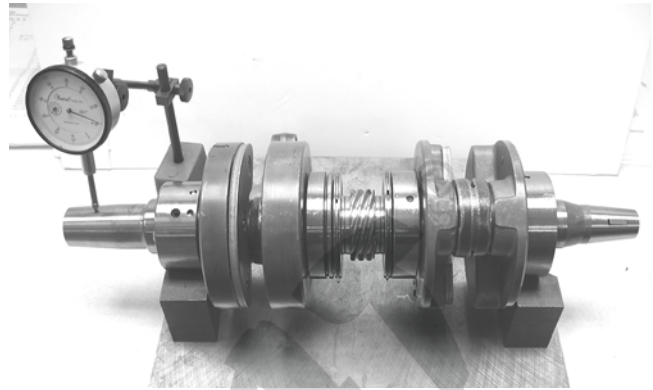

FC046

4. Position the indicator contact point against the crankshaft at location point C (center). Zero the indicator and rotate the crankshaft slowly. Note the amount of crankshaft runout (total indicator reading).

5. If runout exceeds 0.002 in. at any of the checkpoints, the crankshaft must be either straightened or replaced.

Assembling

■NOTE: The use of new gaskets and seals is recommended when assembling the engine.

■NOTE: Prior to assembling the engine, use parts cleaning solvent and compressed air and thoroughly clean the threaded holes of the crankcase and cylinders to properly tighten.

⚠ WARNING

Always wear safety glasses when drying components with compressed air.

■NOTE: When the use of a lubricant is indicated, use Arctic Cat Synthetic APV 2-Cycle Oil.

1. Apply a thin coat of grease to the inner seal lips of the water pump seal.
2. Using the seal driver, position the inner water pump shaft seal onto the seal driver and gently tap the seal down into position.

■NOTE: Grease must be applied to the lips of the inner seal before installation.

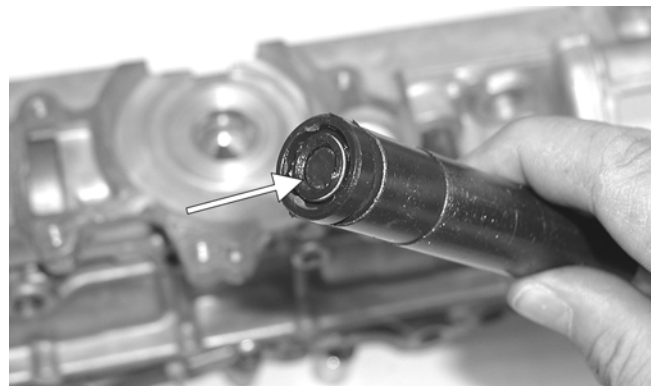

MS986A

■NOTE: The seal must be installed with its spring side towards the crankshaft.

3. Install the snap ring securing the inner seal in the crankcase.



MS415

4. Using the seal driver, carefully install the outer water pump seal. Gently tap the seal down into position until it seats itself against its flange.

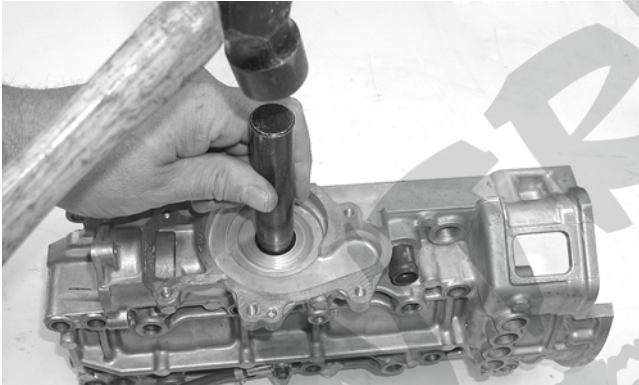

MS988

5. Secure the upper crankcase half upside-down on a suitable support; then install the C-ring (A), the four bearing retaining pins (B), and the two crankcase dowel pins (C).

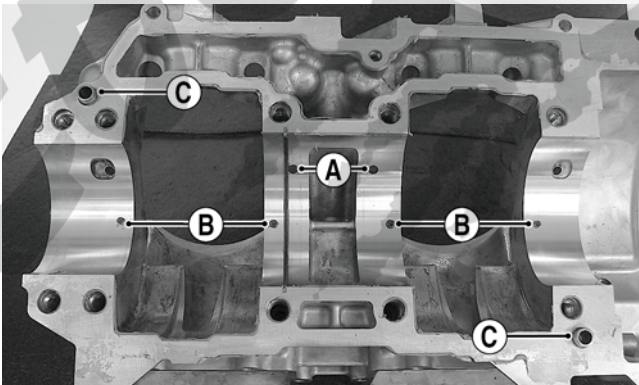

IO023A

6. Place the crankshaft end bearings into position making sure the bearing retaining pin hole is positioned inward.

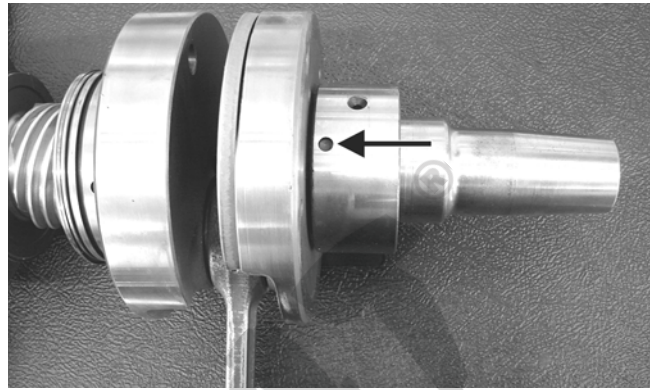

CM043A

7. Lubricate the inner lips of the crankshaft oil seals with grease; then slide the seals onto the crankshaft making sure the spring side of each seal faces inward.
8. Apply oil to the crankshaft bearings; then install the crankshaft into the upper crankcase half. Be sure the alignment hole in each bearing is positioned over its respective retaining pin in the crankcase; then seat the crankshaft.

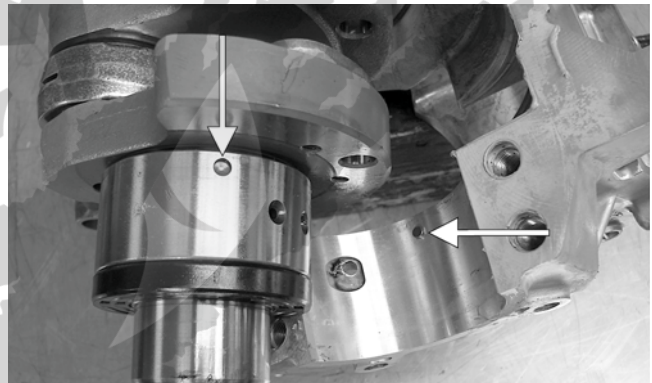

IO019A

■NOTE: To check the bearing for proper position, place the point of a sharp tool into the dimple found in the bearing race. Strike the tool with the palm of the hand in either direction. If the bearing moves, it isn't positioned correctly and must be rotated until it drops onto the retaining pin.

CAUTION

If the bearings are not properly seated during assembly, the crankcase halves will not seal tightly and severe engine damage will result.

9. Position the two center seal rings with their end gaps 180° apart (up on one and down on the other); then apply a thin coat of High-Temp Sealant to the entire bottom half of the crankcase sealing surface.

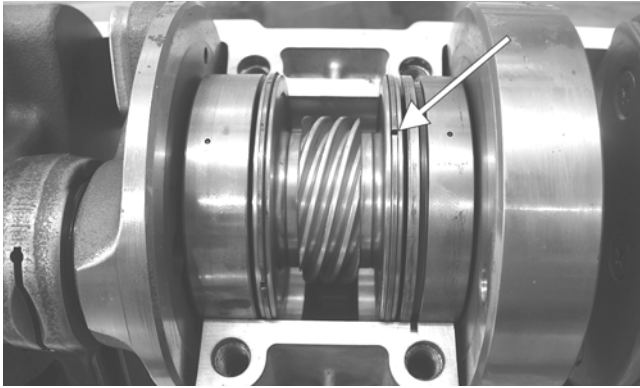

CM036A

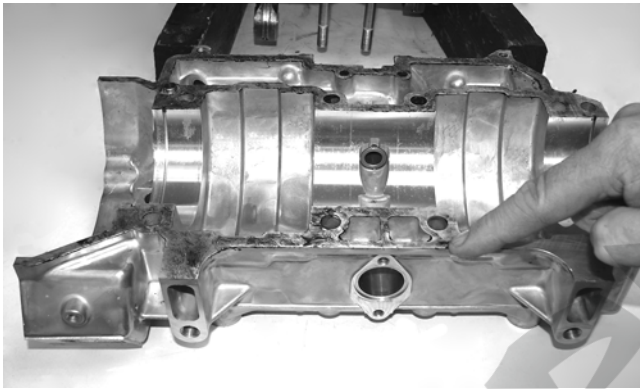

CM166

10. Assemble the crankcase halves making sure the crankshaft gear and oil-injection pump driveshaft gears mesh. Rotate the crankshaft one full turn to align the crankshaft gear and pump driveshaft.
11. Install the crankcase cap screws securing the crankcase halves.
12. Tighten cap screws (1-10) in two steps from 13 ft-lb to 31 ft-lb using the pattern shown.

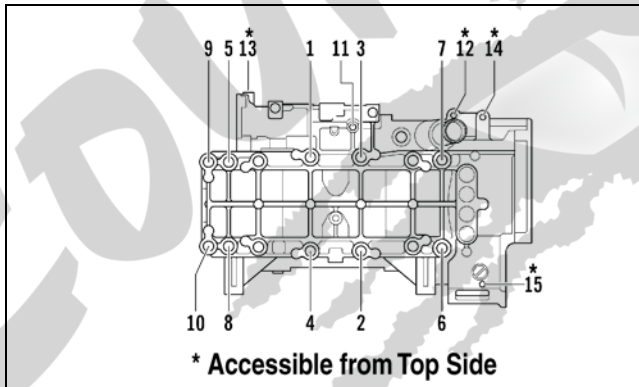

742-198A

13. Tighten cap screw (11) to 96 in.-lb; then turn the engine right-side up and tighten cap screws (12-15) in two steps to 25 ft-lb.

14. Apply a thin coat of grease to the sealing surface of the oil-injection pump/water pump driveshaft; then place the Oil Seal Protector Tool at the end of the shaft.

CAUTION

Be very careful not to damage the seals when installing the oil pump driveshaft. Twist the driveshaft clockwise as it enters the seal area and while pushing it through the seals.



FS191

15. Rotate the oil-injection pump/water pump driveshaft while carefully pushing it through the oil and water pump seals until the driveshaft and crankshaft gears engage; then remove the oil seal protector tool (A) from the end of the shaft.

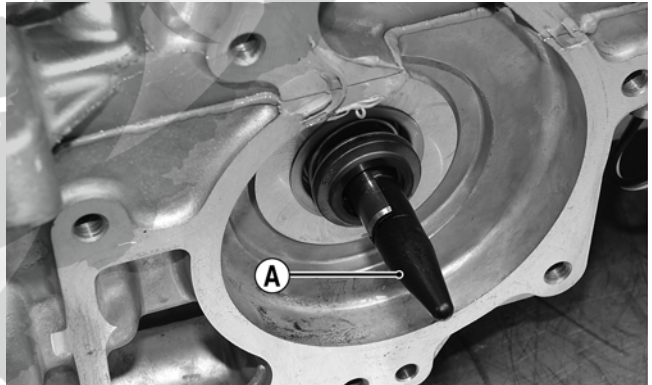

IO025A

16. Position the shim (A) on the oil-injection pump end of the driveshaft; then install the oil-injection pump retainer (B) with a new O-ring.

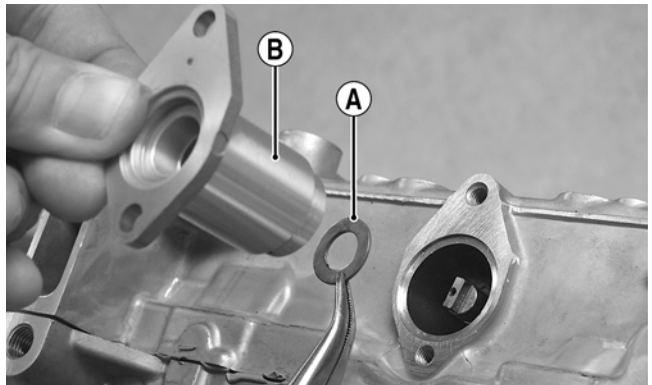

IO026A

17. With the new O-ring (lightly coated with oil) in place, install the oil-injection pump making sure the pump shaft slot (A) and pump driven gear shaft (B) align. Secure with two screws (coated with blue Loctite #243). Tighten the two screws to 96 in.-lb.

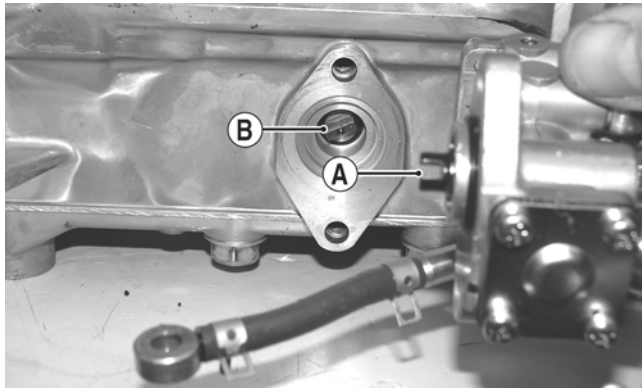

CM167A

CAUTION

Be sure the oil-injection pump/water pump driveshaft is properly aligned with the slot of the oil-injection pump. The pump will be damaged if these two components are not aligned.

18. Place the lower union assembly (with new gaskets) into position and secure with the gaskets and union cap screw. Tighten to 48 in.-lb.

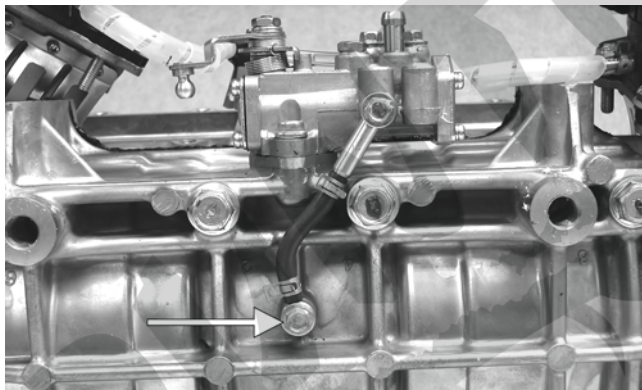

CM153A

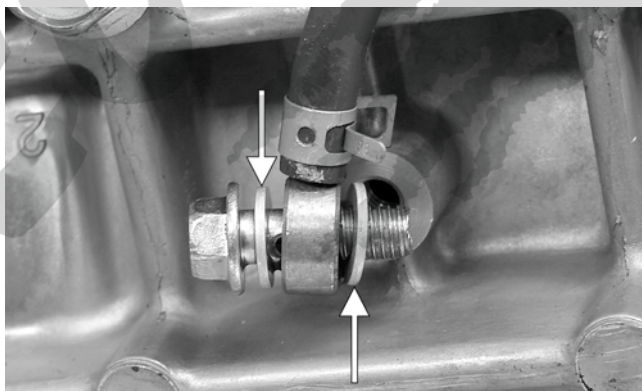

IO020A

CAUTION

Always use new gaskets and assure that a gasket is in place on each side of the union prior to securing the union cap screw to the crankcase.

19. With new gaskets, install the reed valve assemblies and intake flanges using the pattern shown. Tighten to 96 in.-lb; then secure the intake flange oil hoses to the oil pump and secure with the clamps.

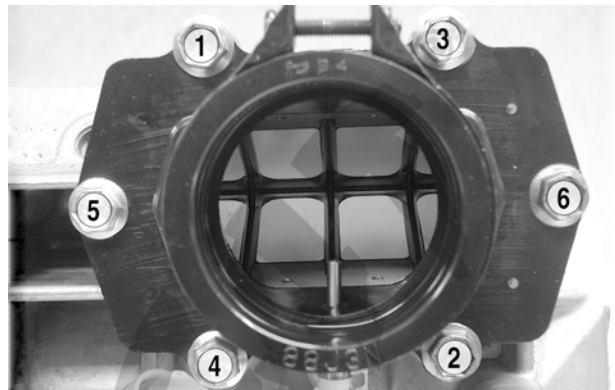

IO021A

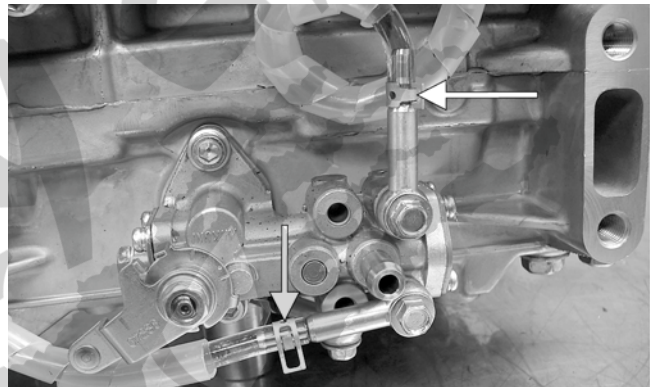

IO022A

20. Install the coolant temperature sensor (threads coated with white Loctite #575) and tighten to 18 ft-lb; then secure the sensor wire to the sensor with a cable tie.
21. Position the ceramic/rubber seal into the back side of the water pump impeller with the ceramic face of the seal directed out.



CM168

22. Using a suitable tool, press the seal into position making sure its marked side is positioned towards the rubber seal cup; then apply a thin coat of grease to the seal outer surface.

CAUTION

When installing the ceramic/rubber seal into the impeller, never touch the ceramic part of the seal. Make sure components are clean and free of any dirt or contaminants.

23. Place the impeller into position and secure with a cap screw and washer. Be sure the rubber side of the washer is lubricated with a light coat of grease and directed toward the impeller. Apply blue Loctite #243 to the threads of the cap screw and tighten to 108 in.-lb.

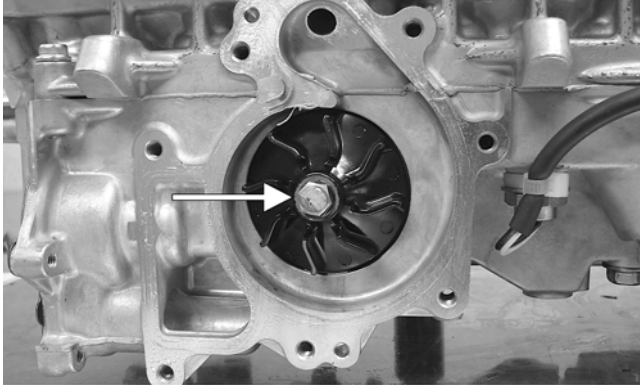

IO018A

CAUTION

The rubber side of the washer securing the impeller must be positioned toward the impeller. If installed incorrectly, a coolant leak will result.

24. Apply High-Temp Sealant to the crankcase/water pump cover seam; then install the dowel pins into the crankcase.
25. Apply a thin film of low-temp grease to the water pump cover O-ring; then position the O-ring into the water pump cover. With the alignment pins in place, install the cover. Secure with the screws using the pattern shown. Tighten to 96 in.-lb.

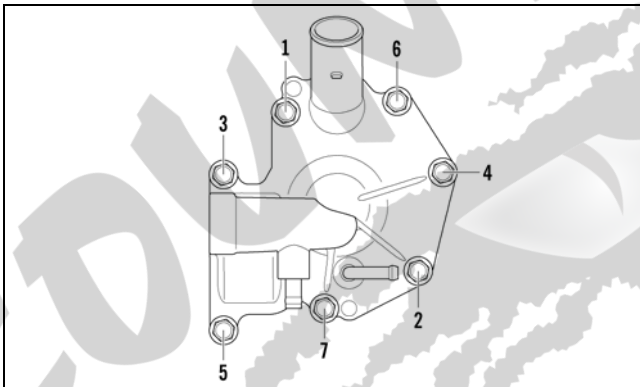

0742-257

26. With the bypass valve of the thermostat directed to the 12 o'clock position, install the thermostat and housing; then in a crisscross pattern, tighten the cap screws to 96 in.-lb.

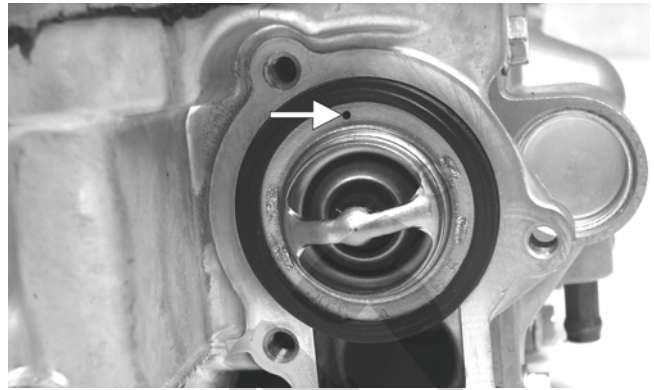

CM157A

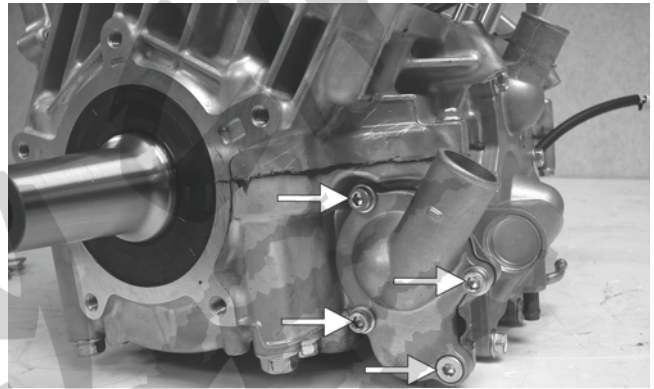

CM155A

27. Install the dowel pins into the crankcase; then place the cylinder base gasket into position on the crankcase.
28. Install the piston rings on each piston so the letter on the top (inclined surface) of each ring faces the dome of the piston.

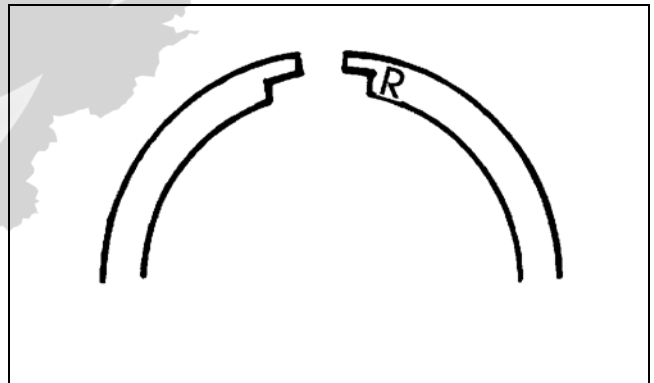

726-306A

CAUTION

Incorrect installation of the piston rings will result in engine damage.

29. Apply oil to the connecting-rod small end bearings; then install the small-end bearings. Install a washer on each side of the connecting rod.

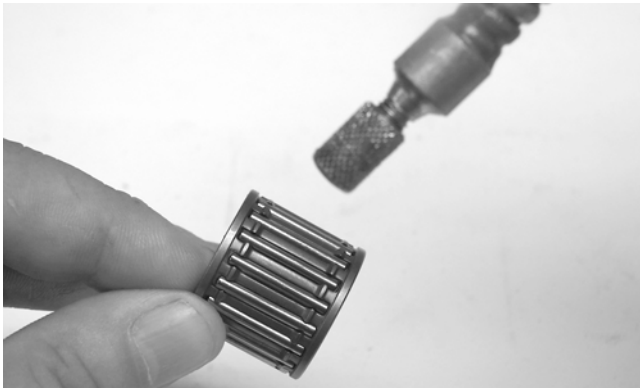

TZ068

■NOTE: The shoulder side of the washer must seat to the needle bearing.



CM172A

30. Place each piston over the connecting rod so the indicator dot on each piston will point toward the intake/exhaust ports; then secure with an oiled piston pin.

■NOTE: The indicator dot is found on the piston dome.

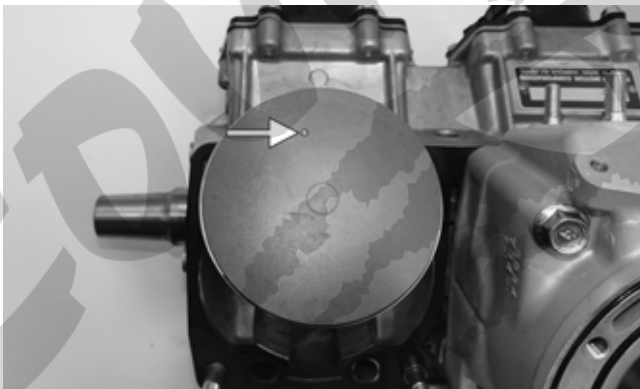

XM019A

31. Install the new circlips so the open end is directed either up or down.

CAUTION

Make sure the circlips are firmly seated before continuing with assembly.

32. Rotate each piston ring until the ring ends are properly positioned on either side of the ring keeper; then apply oil to the piston assemblies and cylinder bores.

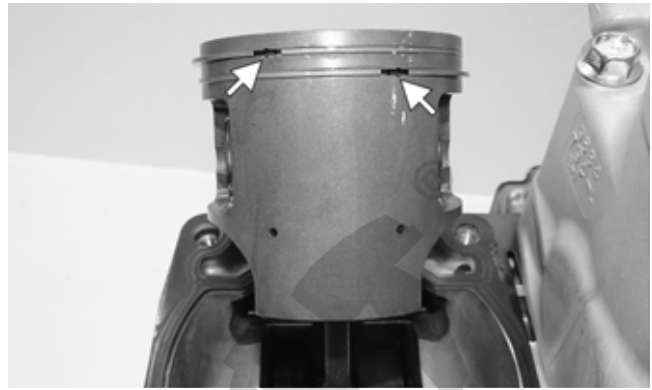

XM021A

33. In turn on each cylinder, place a piston holder (or suitable substitute) beneath the piston skirt and square the piston in respect to the crankcase; then using a ring compressor or fingers, compress the rings and slide the cylinder over the piston. Remove the piston holder and seat the cylinder firmly onto the crankcase.

■NOTE: The cylinders should slide on easily. DO NOT force the pistons into the cylinders.

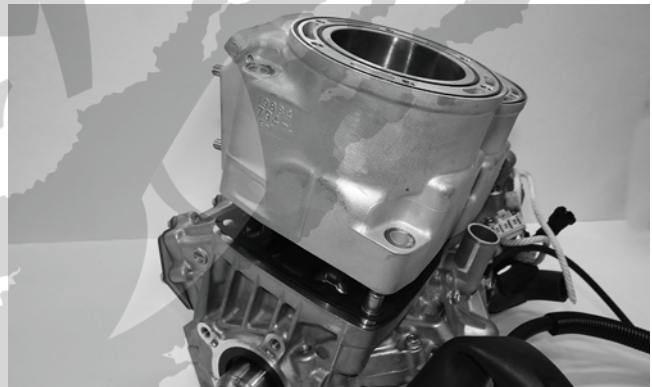

XM018

34. Install each cylinder with the four nuts and four new cap screws; then secure the cylinders by tightening the cylinder base nuts and cap screws to 44 ft-lb in three steps using the pattern shown.

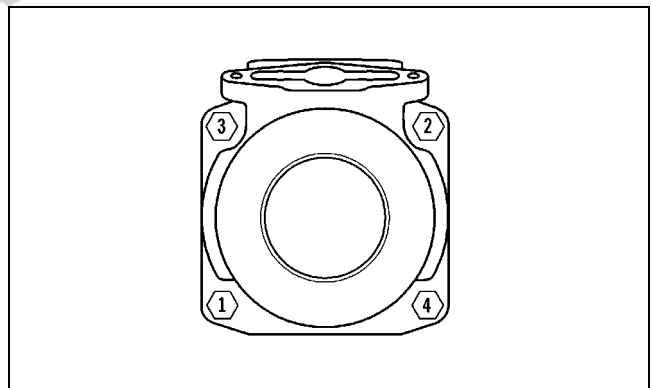

0738-206

■NOTE: Always use new cap screws when installing the cylinders.

35. Install the two cylinder O-rings (lightly coated with oil) on the top of each cylinder making sure they are correctly positioned in the grooves.

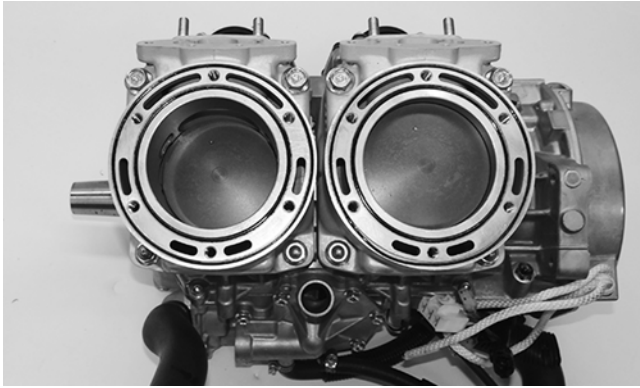

XM022

36. Place new O-rings (lightly coated with oil) onto each of the head cap screws. Place four of these cap screws (from opposite end of each other) into the cylinder head. Thread the spark plugs in part way; then while holding the head above the cylinder, carefully start and finger-tighten all four cap screws while observing the cylinder O-rings to make sure they remain in position. Slowly place the head into position on top of the O-rings.

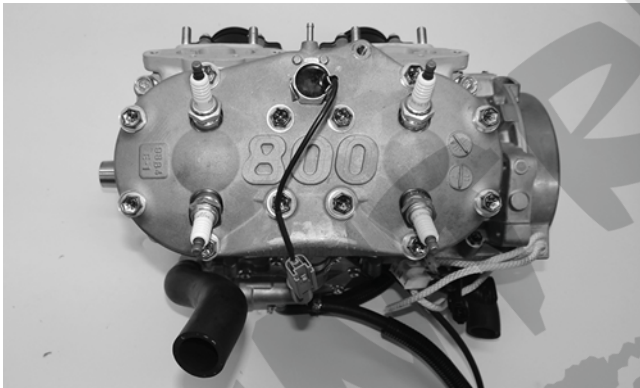

XM016

■NOTE: To install the remaining cap screws, the spark plugs must be removed.

37. Start and finger-tighten the remaining cap screws being very careful not to move the cylinder head; then tighten the cap screws in two steps to 25 ft-lb using the pattern shown.

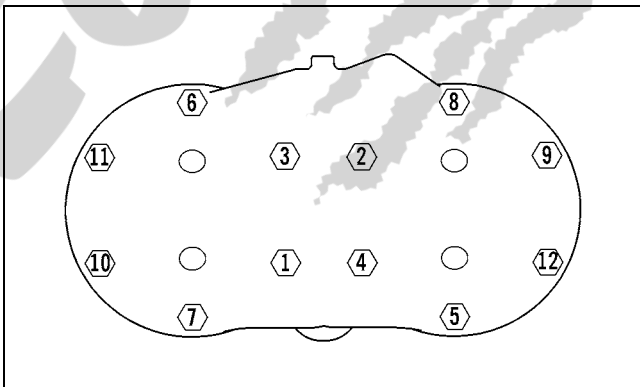

0742-200

■NOTE: At this point, install the spark plugs; then install the knock sensor with the new lock plate, tighten the sensor to 17 ft-lb, and bend the lock plate tabs up.

■NOTE: At this point, pressure test the engine (see the Engine-Related Items section).

38. With the raised edge of the valve aligned with the channel of the cylinder, slide the APV assemblies into position in the cylinders; then secure with cap screws. Tighten to 96 in.-lb.

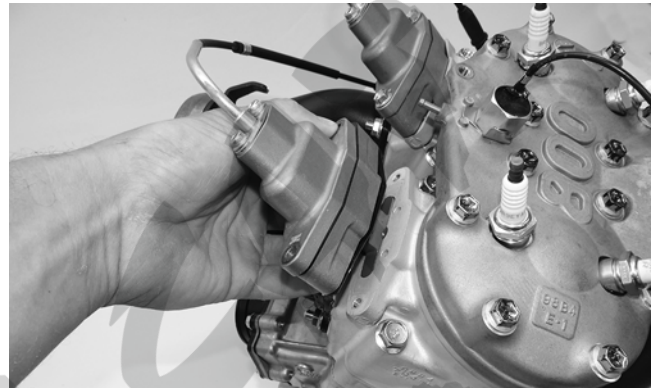

XM017

39. Secure the stator plate to the crankcase with the Allen-head cap screws (coated with blue Loctite #243) and tightened to 96 in.-lb.

40. Route the stator harness through the opening in the crankcase; then secure the stator to the stator plate with the Allen-head cap screws (coated with blue Loctite #243). Tighten to 96 in.-lb.

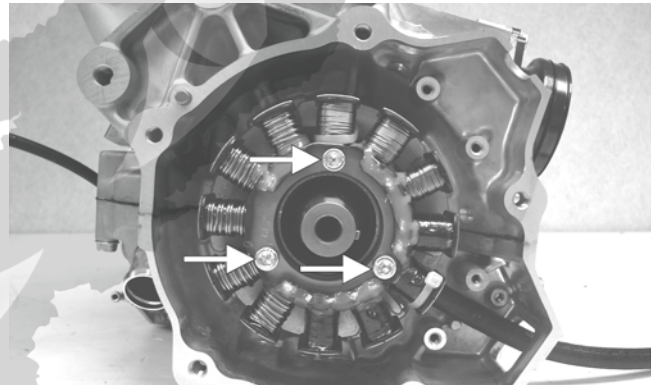

CM143A

41. Secure the upper ignition timing sensor (white dot/connector) with cap screws (coated with blue Loctite #243). Tighten to 48 in.-lb; then install the wiring grommet into the notch of the crankcase.

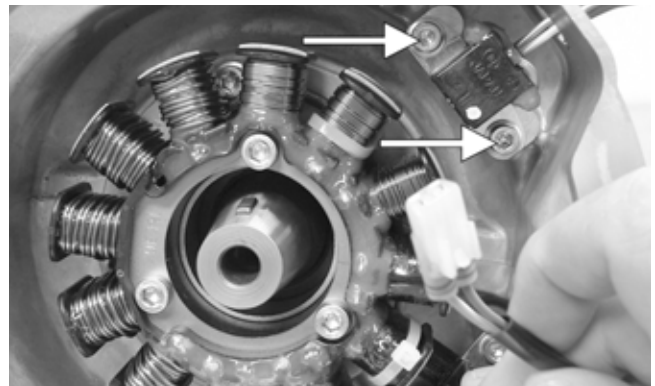

IO049A

42. Secure the lower ignition timing sensor with two cap screws (A) (coated with blue Loctite #243). Tighten to 48 in.-lb; then install the grommet. With the stator harness properly positioned, install the plate and cap screw (B) (coated with blue Loctite #243). Tighten to 48 in.-lb.

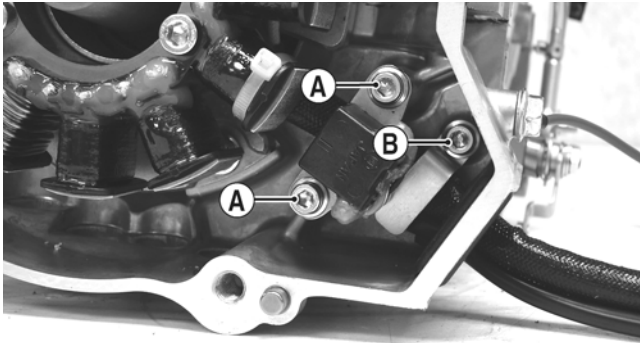

CM177A

43. Install the key in the crankshaft.
44. Place the starter clutch in position on the flywheel; then secure the starter clutch with three cap screws and tighten only until snug. While holding the starter clutch, slide the flywheel onto the crankshaft making sure the keyways match.

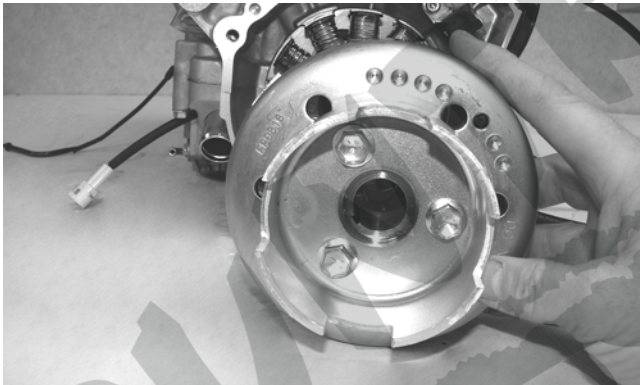

CM180

■NOTE: Before installing the flywheel, be sure to wipe the crankshaft and flywheel tapers clean using a clean, lint-free towel.

45. Apply red Loctite #271 to the threads of the flywheel cap screw; then finger-tighten with a large flat washer. DO NOT TIGHTEN AT THIS TIME.

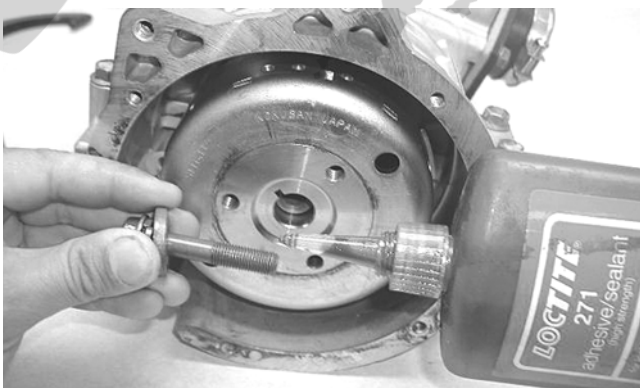

FC080

46. Secure the starter clutch while using the spanner wrench and tighten the three cap screws (from step 45) evenly to 19 ft.-lb.

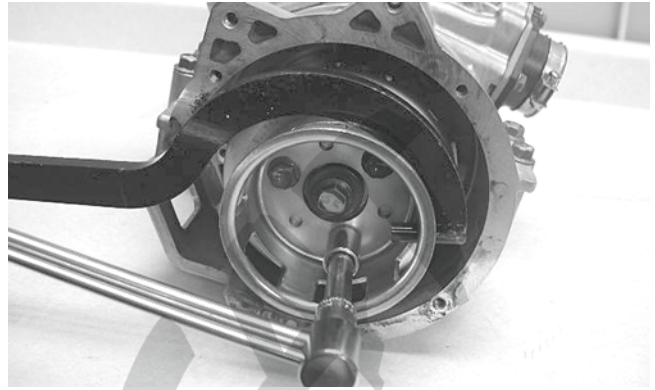

FC081

47. Using the spanner wrench, tighten the flywheel cap screw (from step 45) to 50 ft.-lb.

48. Install the coolant inlet hose to the cylinder head and water pump; then tighten the hose clamps securely.

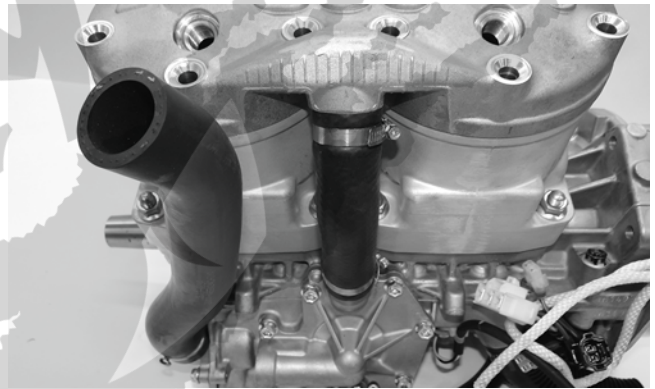

XM023

■NOTE: At this time if the coolant temperature sensor was removed, install the sensor (threads coated with blue Loctite #243) and tighten to 18 ft.-lb.

49. Apply a thin coat of high-temperature silicone sealant to each exhaust port; then install the exhaust gaskets.

50. Apply a thin coat of High-Temp Sealant to the mating surfaces of the exhaust manifold; then install the exhaust manifold and secure with the eight nuts. Tighten the nuts using the pattern shown to 17 ft.-lb.

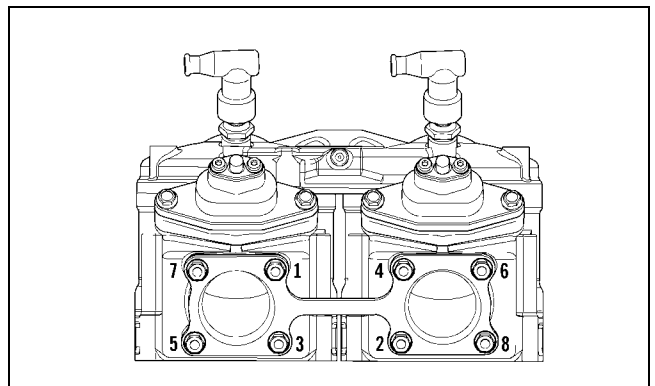

0742-292

Troubleshooting Engine

Problem: Engine Does Not Start (No Spark at Spark Plugs)

Condition	Remedy
<ol style="list-style-type: none"> 1. Key in the OFF position 2. Emergency stop switch in DOWN position — malfunctioning 3. Ground connections dirty — loose 4. RPS switch malfunctioning 5. Wiring harness shorting — disconnected 6. Spark plugs fouled — damaged 7. Spark-plug caps damaged — leaking — shorting 8. High tension leads/coil loose — grounded — faulty 9. Ignition timing sensor faulty 10. Stator faulty 11. ECM/CCU faulty 	<ol style="list-style-type: none"> 1. Turn key to the ON position 2. Move switch to UP position — replace throttle control 3. Check all ground connections — clean and tight 4. Fully seat cable in control housing — Adjust throttle cable tension — replace faulty switch 5. Repair — replace — connect wiring harness 6. Clean — replace spark plugs 7. Replace spark-plug caps 8. Service — replace high tension leads/coil 9. Replace sensor 10. Replace stator 11. Replace ECM/CCU

Problem: Engine Does Not Start (No Fuel at Cylinders)

Condition	Remedy
<ol style="list-style-type: none"> 1. Fuel tank empty 2. Fuel hose broken — pinched 3. Fuel tank vent hose — obstructed 4. Pick-up valve(s) obstructed — damaged 5. Fuel pressure regulator faulty 6. Fuel filter plugged 7. Fuel pump faulty 8. Wiring harness shorting — disconnected 9. Injector (s) stuck closed 10. Primary compression low 11. Stator faulty (Fuel pump or injector coil) 12. ECM faulty 	<ol style="list-style-type: none"> 1. Fill tank 2. Replace hose 3. Remove obstruction — replace vent — hose 4. Remove obstruction — replace pick-up valve(s) 5. Replace regulator — hose 6. Replace fuel filter 7. Service — replace fuel pump — connections — wires 8. Repair — replace — connect wiring harness 9. Replace injector(s) 10. Repair — replace damaged — worn engine components 11. Replace stator 12. Replace ECM

Problem: Engine Does Not Start (Fuel Does Not Ignite)

Condition	Remedy
<ol style="list-style-type: none"> 1. ECM/CCU trouble code 2. Spark absent 3. Fuel contaminated 4. Primary compression low 5. Secondary compression low 6. Engine flooded 7. Sensor(s) faulty 	<ol style="list-style-type: none"> 1. Service — replace problem component 2. Check for spark — see No Spark at Spark Plugs sub-section 3. Replace gasoline 4. Service engine 5. Service engine 6. Clear engine (hold throttle full-open) 7. Repair — replace problem sensor

Problem: Engine Does Not Idle

Condition	Remedy
<ol style="list-style-type: none"> 1. ECM/CCU trouble code 2. Throttle position sensor idle adjustments incorrect 3. ISC faulty 4. Reed petals chipped or broken 5. Injector(s) faulty 6. Fuel pressure regulator faulty 7. Air-intake silencer obstructed 8. Exhaust obstructed 9. Primary compression low 10. Secondary compression low 	<ol style="list-style-type: none"> 1. Service — replace problem component 2. Adjust idle RPM to specifications 3. Replace ISC 4. Replace reed petals 5. Replace injector(s) 6. Replace regulator 7. Clean air-intake silencer 8. Remove obstruction 9. Service Engine 10. Service Engine

Problem: Engine Loses Power or Runs on One Cylinder

Condition	Remedy
<ol style="list-style-type: none"> 1. Sensor faulty 2. Spark plug fouled 3. Injector faulty 4. External coil faulty 5. Fuel tank vent — hose obstructed 6. APV faulty 7. Fuel pressure regulator faulty 8. Pick-up valve(s) obstructed — out of position 9. Secondary compression low 10. Oil-injection pump malfunctioning — adjust incorrectly 11. Throttle bodies out of synchronization 	<ol style="list-style-type: none"> 1. Check ECM for trouble code — repair — replace sensor 2. Replace spark plugs 3. Replace injector 4. Service — replace coil 5. Service — replace vent hose 6. Inspect Cables — set cable tension — clean valves 7. Replace regulator 8. Replace — relocate pick-up valve(s) 9. Service engine 10. Replace — bleed — adjust oil-injection pump 11. Replace throttle bodies from a similar engine — if problem is corrected, replace the original assembly

Problem: Engine Backfires

Condition	Remedy
<ol style="list-style-type: none"> 1. ECM/CCU trouble code 2. RPS switch adjusted incorrectly 3. Spark-plug caps damaged — leaking — shorting 4. Spark plugs fouled - damaged 5. High tension leads/coil shorting or reversed 6. Coil Primary wires reversed 7. Fuel mixture lean 8. Ignition Timing Sensor(s) faulty 9. Oil-injection pump malfunctioning — adjusted incorrectly 10. Reed petals chipped or broken 11. Engine overheated 12. Knock Control system 13. ECM/CCU faulty — damaged 	<ol style="list-style-type: none"> 1. Service — replace problem component 2. Adjust throttle cable tension — service spring 3. Replace spark-plug caps 4. Clean — replace spark plugs 5. Service — replace high tension leads/coil 6. Reverse wires 7. Repair fuel regulator — injector(s) 8. Check Wiring-Replace sensor(s) 9. Replace — bleed — adjust oil-injection pump 10. Replace reed petals 11. Refill coolant — repair Thermostat — repair Water Pump Assembly 12. Replace fuel with higher octane 13. Replace ECM/CCU

Problem: Engine Four-Cycles (Floods Excessively)

Condition	Remedy
<ol style="list-style-type: none"> 1. ECM trouble code 2. Fuel pressure too high 3. Fuel tank vent — hose obstructed 4. Injector(s) faulty 5. Sensor(s) faulty 6. Reed petals chipped or broken 7. Air silencer obstructed 	<ol style="list-style-type: none"> 1. Service — replace problem component 2. Replace regulator — hose 3. Service — replace vent hose 4. Replace injector(s) 5. Repair — replace problem sensor(s) 6. Replace reed petals 7. Remove obstruction

Problem: Engine Stops Suddenly

Condition	Remedy
<ol style="list-style-type: none"> 1. Fuel tank empty 2. Emergency stop switch in DOWN position 3. ECM/CCU trouble code 4. Spark absent 5. Stator faulty 6. Wiring harness shorting — disconnected 7. Fuel filter(s) obstructed 8. Fuel pressure low 9. Fuel pump faulty 10. Fuel tank vent hose obstructed 11. Fuel hose obstructed — broken — pinched 12. RPS switch malfunctioning 13. Engine seized 14. ECM/CCU faulty 	<ol style="list-style-type: none"> 1. Fill tank 2. Move switch to UP position 3. Service — replace problem component 4. See No Spark at Spark Plugs sub-section 5. Replace stator 6. Repair — replace — connect wiring harness 7. Replace filter(s) 8. Replace regulator — hose 9. Service — replace fuel pump 10. Service vent hose 11. Remove obstruction — repair — replace fuel hose 12. Replace throttle control — adjust throttle cable tension 13. Service engine 14. Replace ECM/CCU

Problem: Engine Fails to Stop (Continues to Run, Even with All Switches Off)

Condition	Remedy
<ol style="list-style-type: none"> 1. ECM internal 2. Wiring harness disconnected — faulty harness 3. Key switch faulty 4. Emergency stop switch faulty 	<ol style="list-style-type: none"> 1. Replace ECM 2. Repair — replace — connect wiring harness 3. Replace key switch 4. Replace E-stop control housing

Engine-Related Items

■NOTE: Whenever a part is worn excessively, cracked, or damaged in any way, replacement is necessary.

SPECIAL TOOLS

A number of special tools must be available to the technician when servicing the engine-related items.

Description	p/n
Blind-Hole Bearing Puller	0644-500
Coolant Cap	0644-156
Drive Clutch Spanner Wrench	0644-136
Valve and Spring Retainer Tool	0644-448
Fan Spanner Wrench	0644-340
Water Pump Bearing and Seal Tool Kit	0644-557
Oil Seal Protector Tool	0644-219
Engine Leak-Down Test Kit	0644-522
Vacuum Test Pump	0644-131
Hood Harness Extension	1686-659
Hood Harness Extension	1686-660
Oil Filter Wrench	0644-551

■NOTE: Special tools are available from the Arctic Cat Service Parts Department.

Water Pump - 4000

DISASSEMBLING

■NOTE: The engine must be removed for this procedure (see Section 2).

■NOTE: A bleed hole is located in the crankcase beneath the water pump housing. If any signs of coolant leakage from the bleed hole exist, the water pump seals must be replaced. When servicing the water pump, use Water Pump Bearing and Seal Tool Kit.

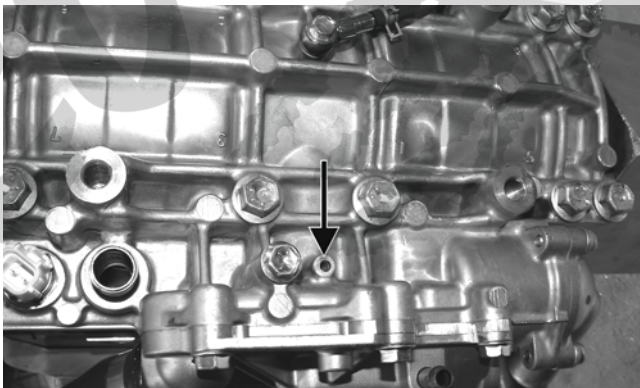

FS237A

1. Remove the cap screws securing the water pump cover; then remove the cover and account for the O-ring seal.

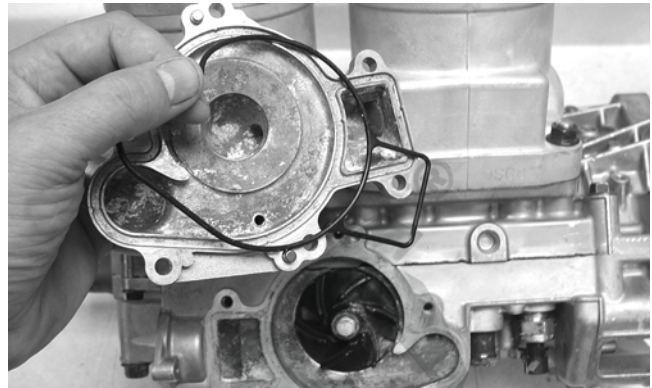

FC118

2. Remove either lower union cap screw securing the lower check valve assembly. Remove the two cap screws securing the oil-injection pump and pull the oil pump from the engine. Leave the pump hose and cable attached.
3. Remove the cap screw securing the impeller. Account for the rubber washer behind the cap screw.

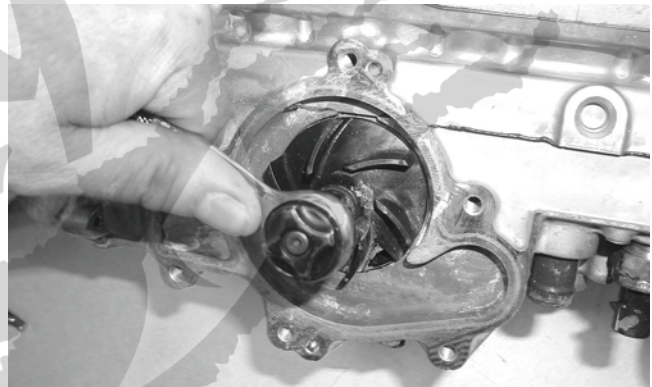

FC119

4. Remove the impeller from the shaft.



FC120

■NOTE: If the impeller will not slide off the shaft, start the cap screw into the shaft and tap on the cap screw driving the shaft back out of the impeller.

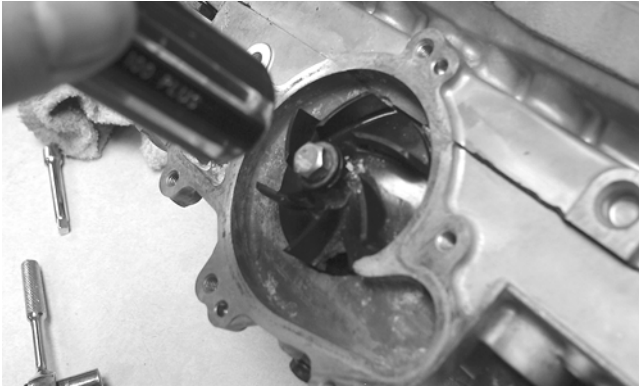

FC121

5. Remove the oil-injection pump retainer and shaft from the opposite side of the crankcase. Account for the thrust washer located between the retainer and shaft flange.



FC124

8. Using the hooked end of the long seal driver, pull the inner seal free of the crankcase.

ASSEMBLING

1. Wipe the seal area clean using a clean rag.

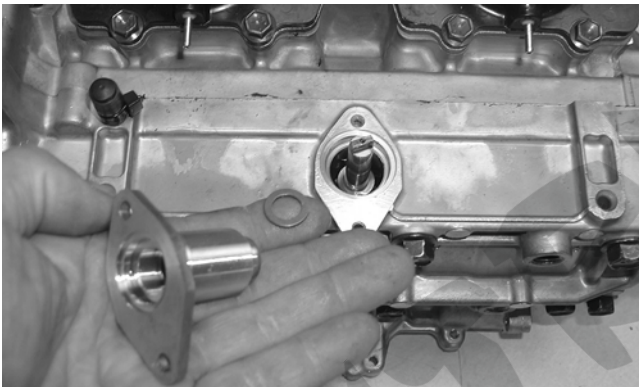

FC122

6. Using the long seal driver, drive the water pump mechanical seal from the crankcase.

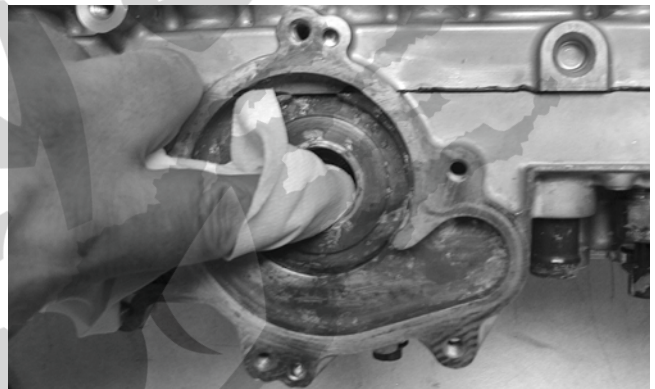

FC125

2. Position the inner seal onto the seal driver (spring side towards the crankshaft). Gently tap into position.

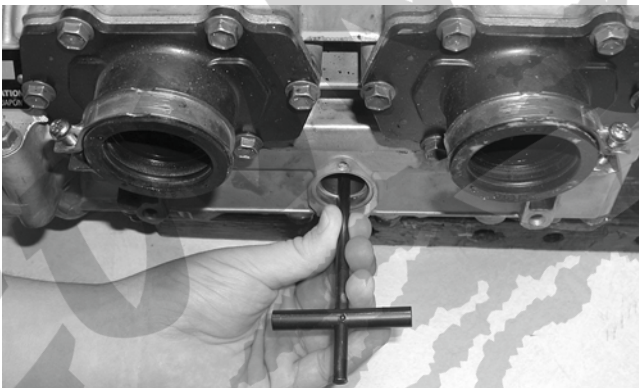

FC123

7. Using a pair of snap ring pliers, remove the snap ring securing the inner seal in the crankcase.

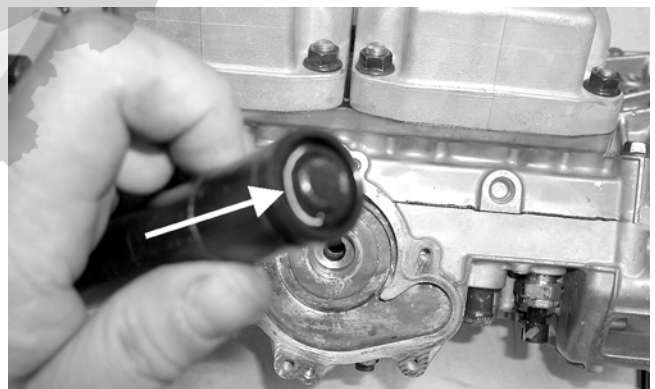

FC126A

3. Using a small screwdriver, apply a light coat of grease to the inner seal lips.

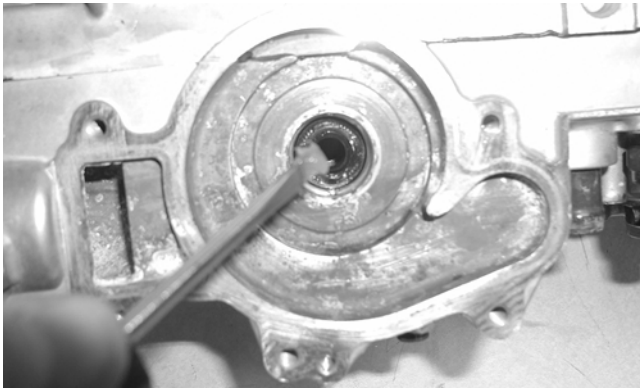

FC127

- Using a pair of snap ring pliers, install the snap ring securing the inner seal in the crankcase.

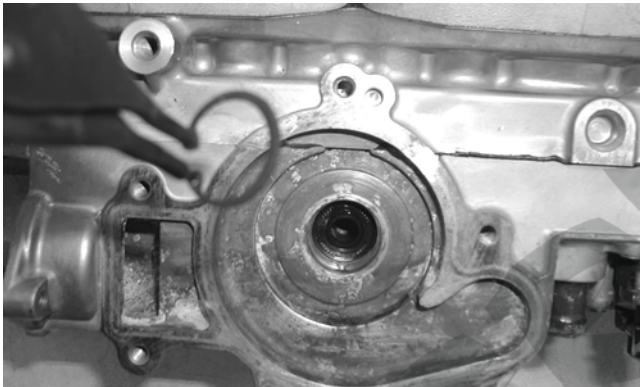

FC128

- Using the seal driver, carefully install the outer water pump mechanical seal. Gently tap the seal down into position until it seats itself against its flange.

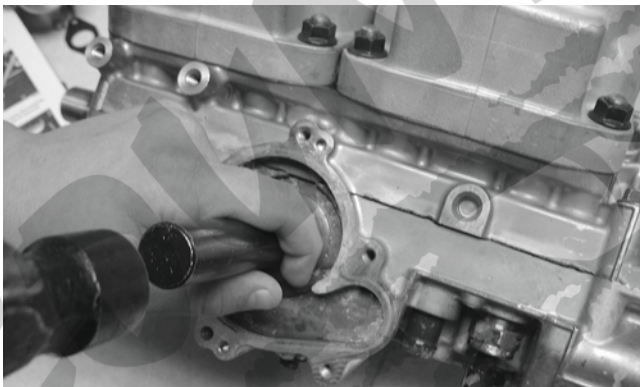

FC129

- Apply a light coat of grease to the sealing surface of the oil-injection pump driveshaft; then install Oil Seal Protector Tool at the end of the shaft. Twist the shaft while pushing it through the oil and water pump seals; then remove the tool.

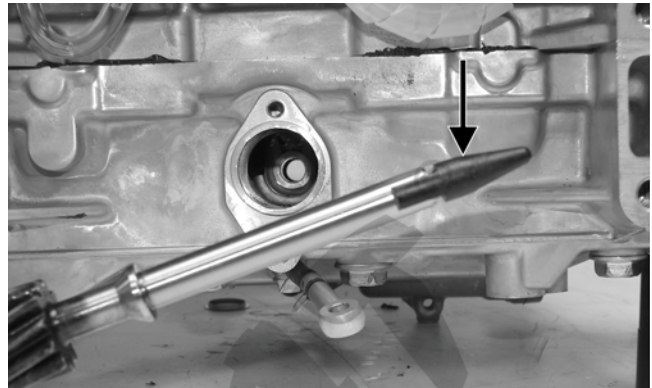

FS233A

- Position the shim on the oil pump end of the shaft; then with the O-ring installed on the retainer, install the oil-injection pump retainer.

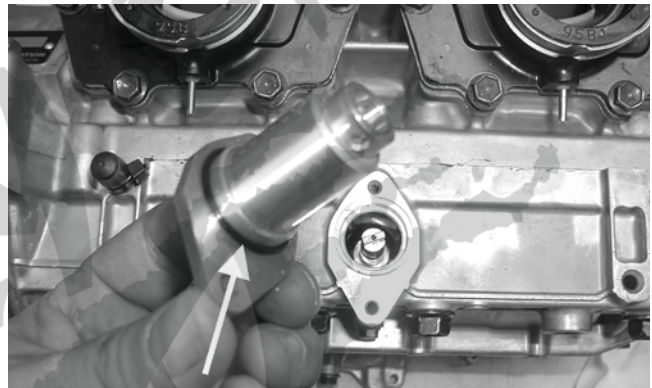

FC130A

■ **NOTE:** For assembling purposes, always use new O-rings lubricated with oil on the oil injection pump and retainer.

- With the O-ring in place on the oil-injection pump, align the pump with the shaft; then install the pump. Secure with two cap screws (coated with blue Loctite #243). Tighten the two cap screws to 96 in.-lb.

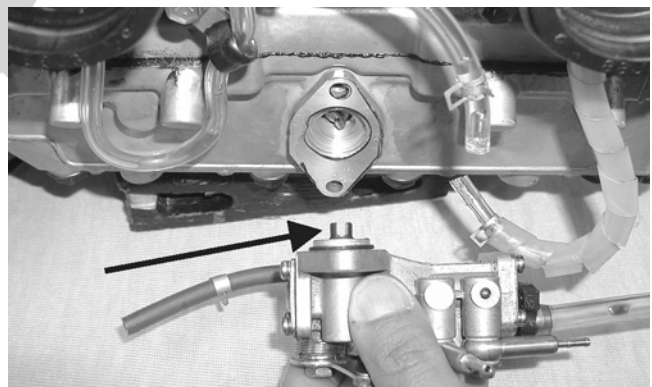

FC131A

■ **NOTE:** After the oil pump has been secured, assure that the oil hoses from the pump and intake flanges are routed properly.

- Place the lower check valve into position; then secure with the washer gaskets and union cap screw. Tighten securely.

■NOTE: When installing the lower check valve, assure that the washer gaskets are installed on each side of the valve.

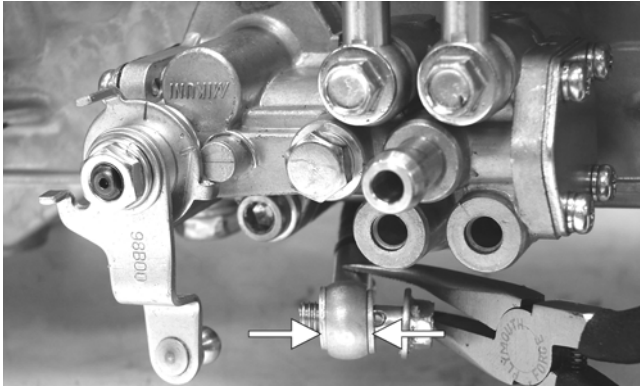

FS235A

10. Place the impeller into position and secure with a cap screw and washer. **Be sure the rubber side of the washer is lubricated with a fine coat of oil and directed towards the impeller.** Apply blue Loctite #243 to the threads of the cap screw and tighten to 108 in.-lb.

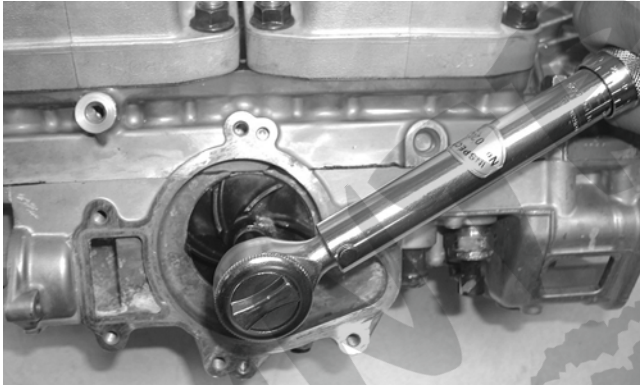

FC132

11. Apply sealant to the crankcase seam; then install the alignment pins into the crankcase (if removed).

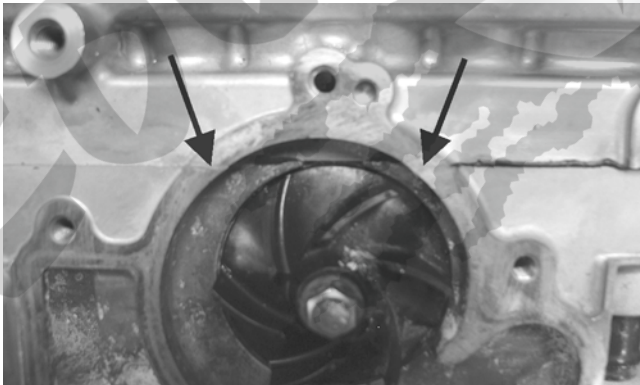

FC133A

■NOTE: Do not allow sealant into the breather hole in the crankcase. If sealant gets into the hole, carefully remove before proceeding.

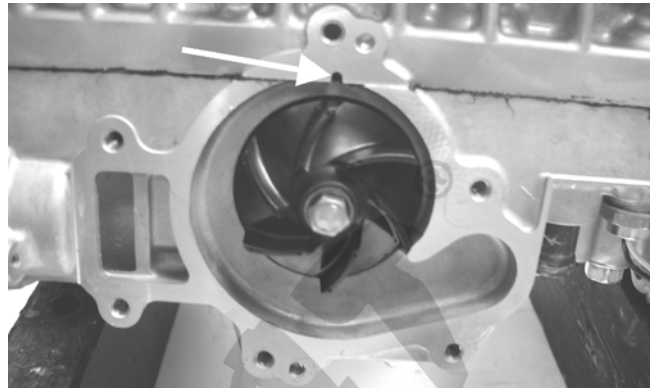

FC072B

12. Position the O-ring into the water pump cover; then install the cover. Install the cap screws; then using the pattern shown, tighten to 96 in.-lb.

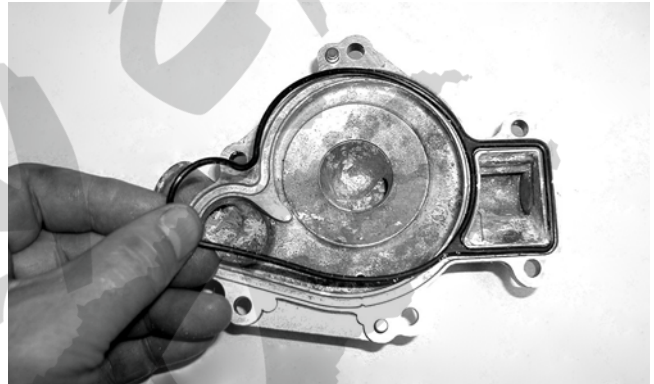

FC134

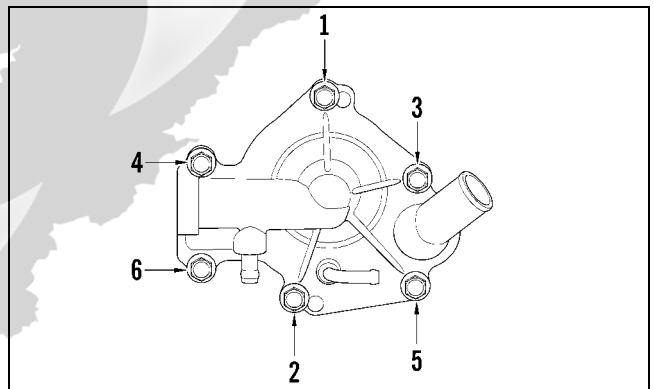

0742-304

Water Pump - 6000

DISASSEMBLING

■NOTE: The engine must be removed for this procedure.

■NOTE: A bleed hole is located in the crankcase beneath the water pump housing. If any signs of coolant or oil leakage from the bleed hole exist, the seals must be replaced.

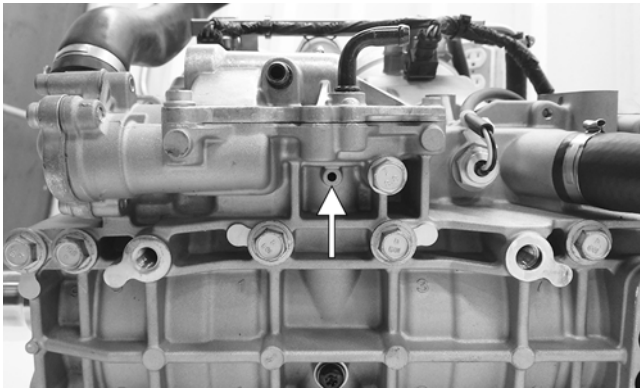

CWI-094A

■NOTE: When servicing the water pump, use Water Pump Bearing and Seal Tool Kit and Oil Seal Protector Tool.

■NOTE: Tip the crankcase assembly up onto the water pump side; then remove the black torx-screw from the bottom of the crankcase and tip down and drain the injection oil from the center cavity into a container.

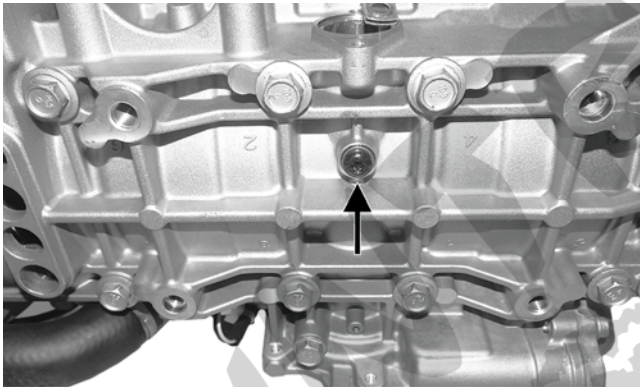

CWI-023A

1. Loosen the clamps securing the coolant hoses to the water pump; then remove the hoses.
2. Remove the seven screws securing the water pump cover; then remove the cover and account for the O-ring seal and two dowel pins.

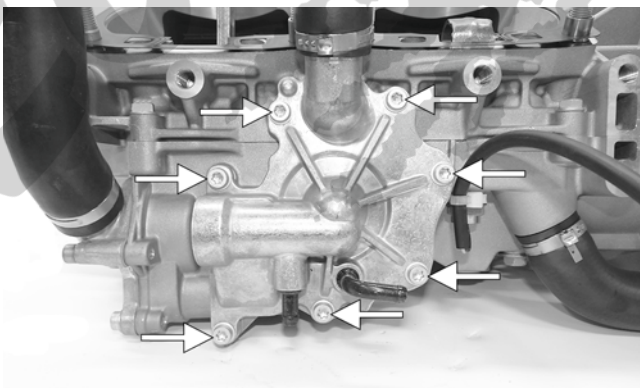

CWI-016A

3. Remove the cap screw securing the impeller. Account for the rubber washer and gasket behind the cap screw. Remove the impeller from the shaft.



CWI-082

■NOTE: If the impeller will not slide off the shaft, start the cap screw into the shaft and tap on the cap screw driving the shaft back out of the impeller.

4. Remove the retainer and shaft from the opposite side of the crankcase. Account for the shim located between the retainer and shaft flange.

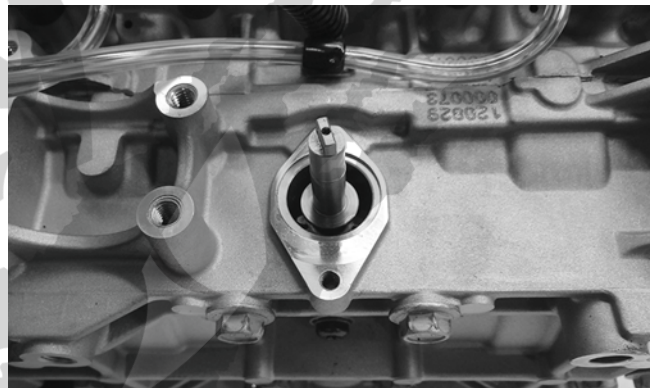

CWI-097

5. Using the long seal driver, drive the water pump mechanical seal from the crankcase.
6. Using a pair of snap ring pliers, remove the snap ring securing the oil seal in the crankcase.

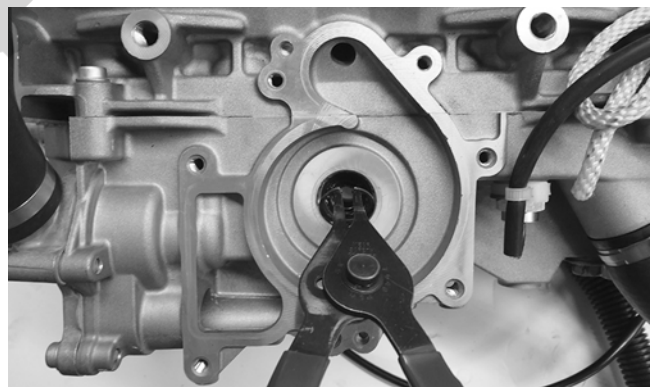

CWI-098

9. Using the hooked end of the long seal driver, pull the inner seal free of the crankcase.

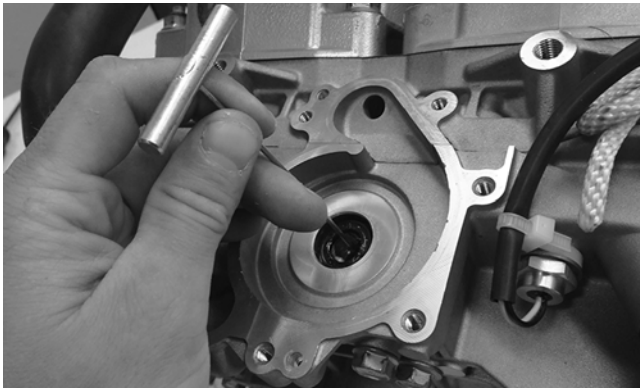

CWI-099

ASSEMBLING

1. Thoroughly clean the seal surfaces of the crankcase.
2. Position new oil seal onto the seal driver (spring side towards the crankshaft). Gently tap into position.



FS230

3. Apply a small amount of grease to the oil seal lips.
4. Using a pair of snap ring pliers, install the snap ring securing the oil seal in the crankcase.

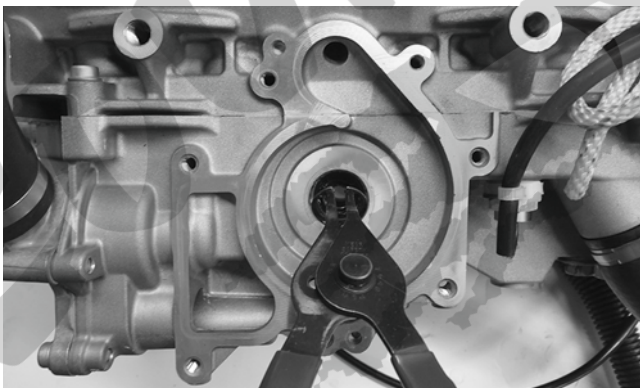

CWI-098

5. Using the seal driver, carefully install the outer water pump mechanical seal. Gently tap the seal down into position until it seats itself against the crankcase.

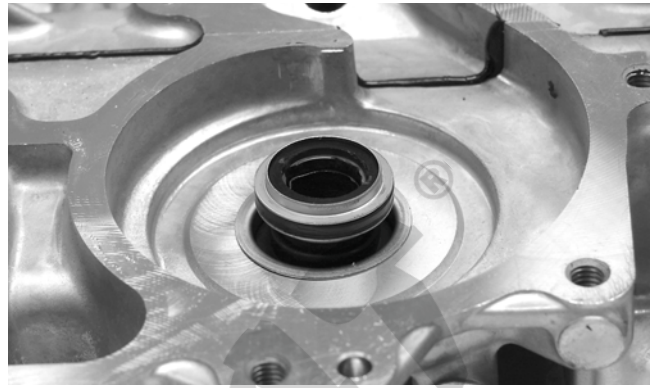

FS232

6. Apply a light coat of grease to the sealing surface of the pump driveshaft; then install Oil Seal Protector Tool at the end of the shaft. Twist the shaft while pushing it through the water pump seals until the shaft gear engages with the drive gear of the crankshaft; then remove the tool.

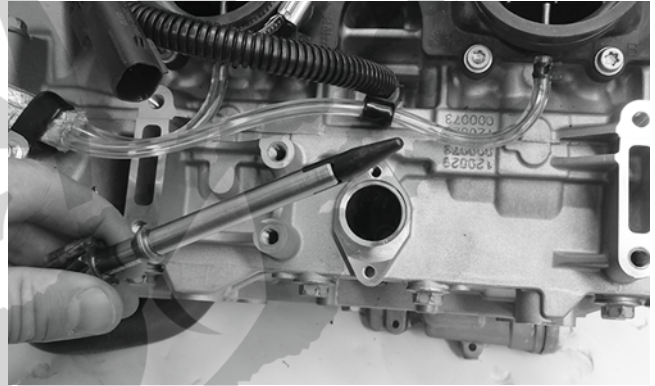

CWI-101

7. Position the shim on the retainer end of the shaft; then with the O-ring in place on the retainer, install the retainer.

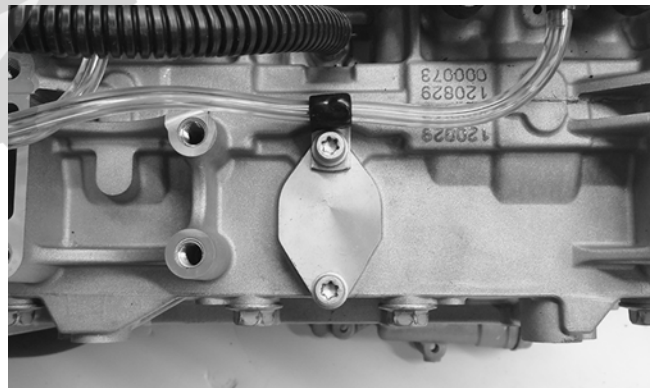

CWI-100

9. Place the impeller into position and secure with a cap screw and washer. **Be sure the rubber side of the washer is directed towards the impeller.** Apply blue Loctite #243 to the threads of the cap screw and tighten to 48 in.-lb.

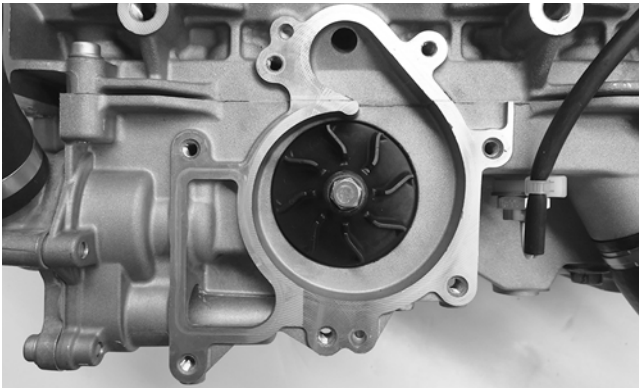

CWI-096

11. Position the O-ring into the water pump cover; then install the cover. Install the cap screws; then tighten to 96 in.-lb using a crisscross pattern.

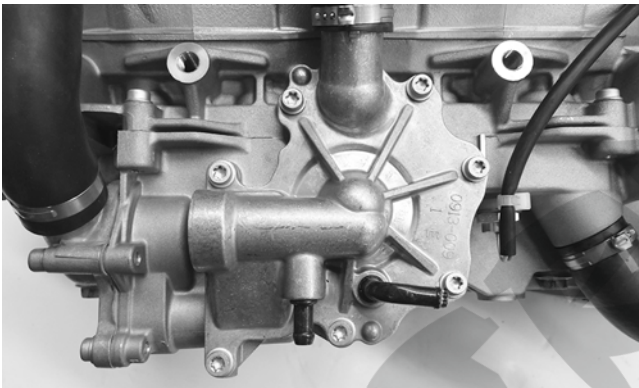

CWI-095

12. Secure the hoses to the water pump cover.

Water Pump - 8000

DISASSEMBLING

■NOTE: The engine must be removed for this procedure.

■NOTE: A bleed hole is located in the crankcase beneath the water pump housing. If any signs of coolant leakage from the bleed hole exist, the water pump seals must be replaced.

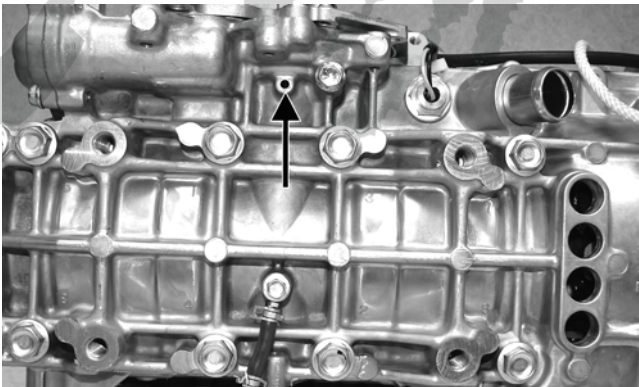

FS219A

■NOTE: When servicing the water pump, use Water Pump Bearing and Seal Tool Kit and Oil Seal Protector Tool.

1. Loosen the clamps securing the coolant hoses to the water pump; then remove the hoses.

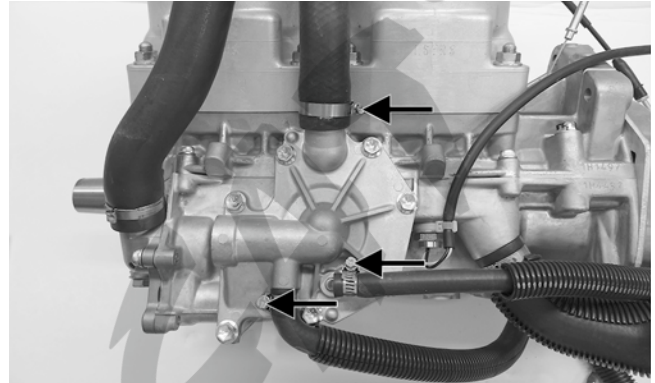

XM114A

2. Remove the seven cap screws securing the water pump cover; then remove the cover and account for the O-ring seal and two dowel pins.

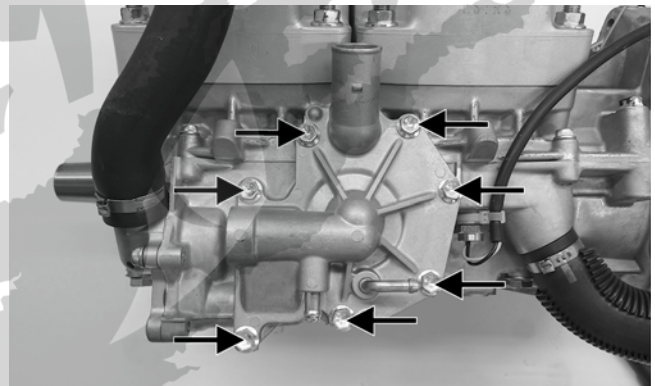

XM113A

3. Remove the cap screw (A) securing the lower check valve to the oil pump and account for the two gaskets; then remove the two cap screws (B) securing the oil pump to the engine. Remove the pump.

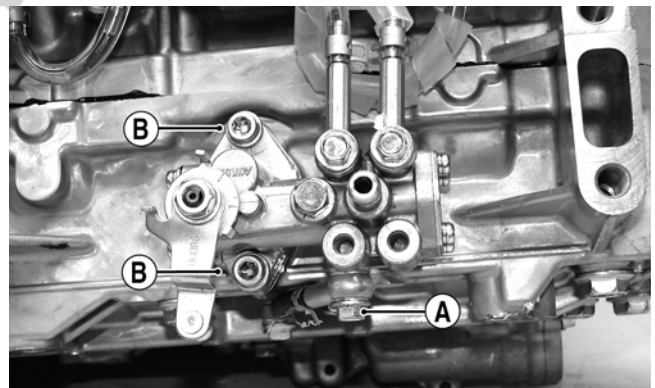

FS220A

■NOTE: Leave the two upper check valves secured to the pump.

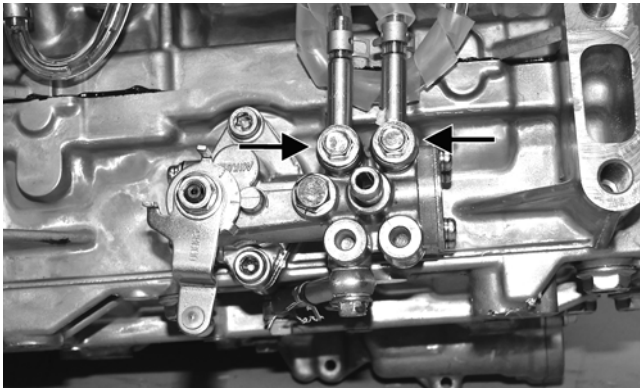

FS221A

- Remove the cap screw securing the impeller. Account for the rubber washer and gasket behind the cap screw.

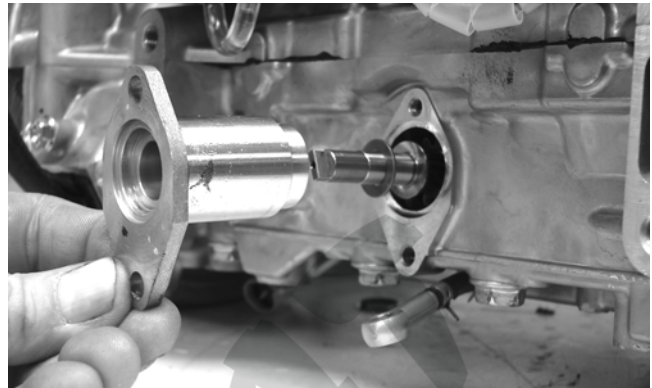

FS226

- Using the long seal driver, drive the water pump mechanical seal from the crankcase.

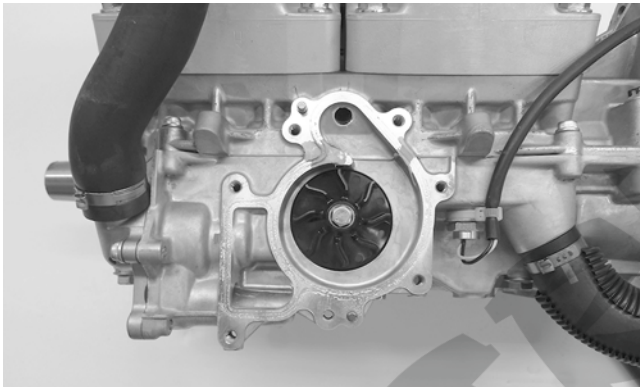

XM112

- Remove the impeller from the shaft.



FS227

- Using a pair of snap ring pliers, remove the snap ring securing the oil seal in the crankcase.

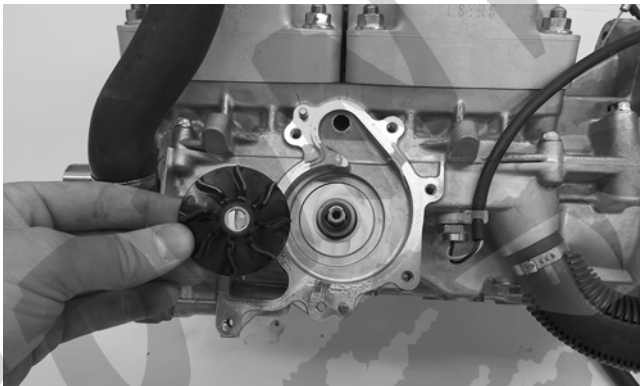

XM111

■NOTE: If the impeller will not slide off the shaft, start the cap screw into the shaft and tap on the cap screw driving the shaft back out of the impeller.

- Remove the oil-injection pump retainer and shaft from the opposite side of the crankcase. Account for the shim located between the retainer and shaft flange.

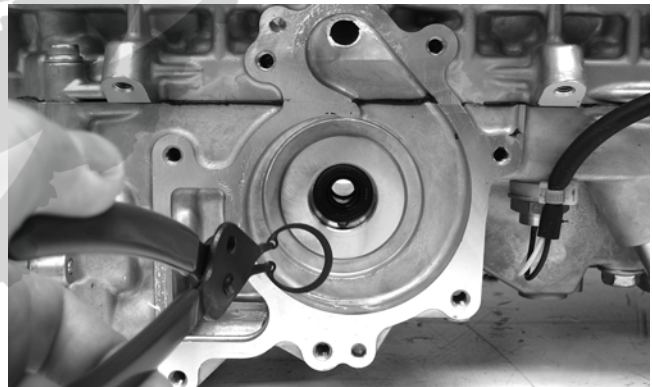

FS228

- Using the hooked end of the long seal driver, pull the inner seal free of the crankcase.

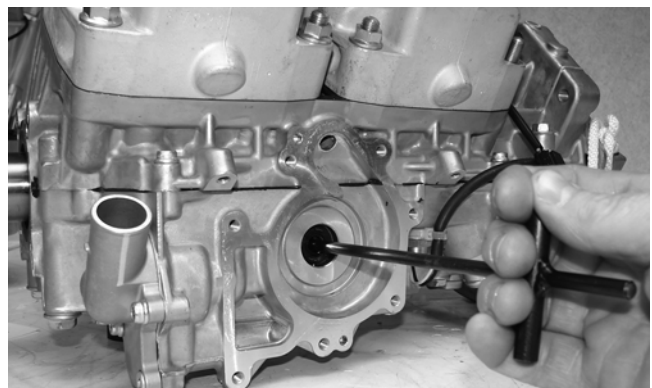

FS229

ASSEMBLING

1. Thoroughly clean the seal surfaces of the crankcase.
2. Position the oil seal onto the seal driver (spring side towards the crankshaft). Gently tap into position.



FS230

3. Apply a small amount of grease to the oil seal lips.
4. Using a pair of snap ring pliers, install the snap ring securing the oil seal in the crankcase.

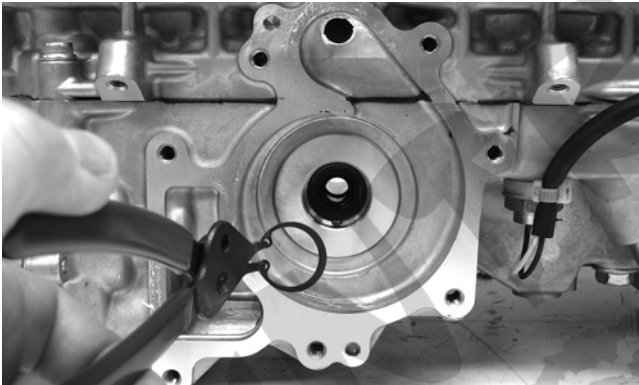

FS228

5. Using the seal driver, carefully install the outer water pump mechanical seal. Gently tap the seal down into position until it seats itself against the crankcase.



FS232

6. Apply a light coat of grease to the sealing surface of the oil-injection pump driveshaft; then install Oil Seal Protector Tool at the end of the shaft. Twist the shaft while pushing it through the oil and water pump seals until the shaft gear engages with the drive gear of the crankshaft; then remove the tool.

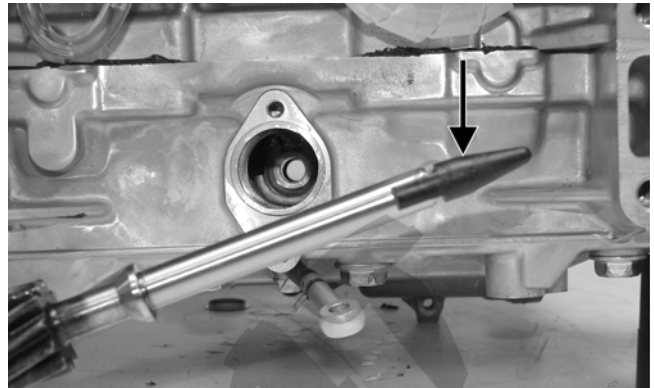

FS233A

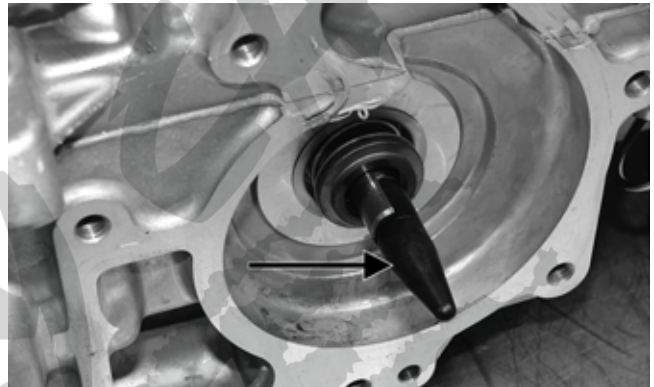

IO025B

7. Position the shim (A) on the oil pump end of the shaft; then with the O-ring in place on the retainer (B), install the oil-injection pump retainer.

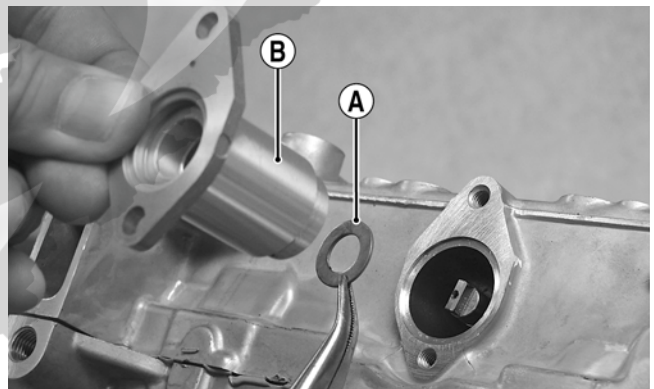

IO026A

8. With the O-ring in place on the oil-injection pump, align the pump with the shaft; then install the pump. Secure with the cap screws (coated with blue Loctite #243) (B) and tighten to 96 in.-lb. Place the lower check valve into position; then secure with the gaskets and cap screw (A). Tighten to 48 in.-lb.

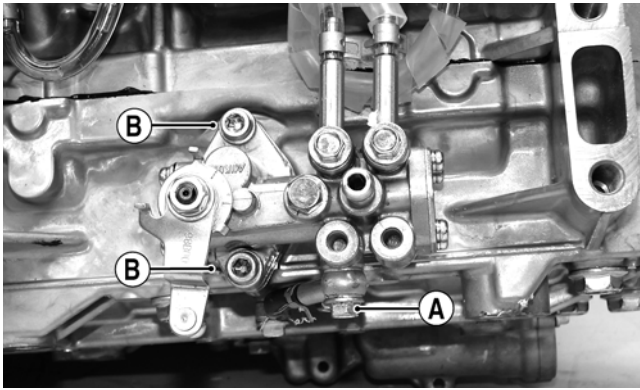

FS220A

■NOTE: When installing the lower check valve, assure that the gaskets are installed on each side of the valve.

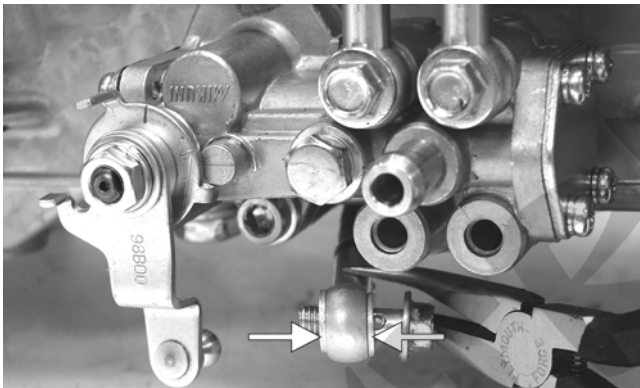

FS235A

■NOTE: After the oil pump has been secured, assure that the oil hoses from the pump to the intake flanges are routed properly.

- Place the impeller into position and secure with a cap screw and washer. Be sure the rubber side of the washer is directed towards the impeller. Apply blue Loctite #243 to the threads of the cap screw and tighten to 48 in.-lb.

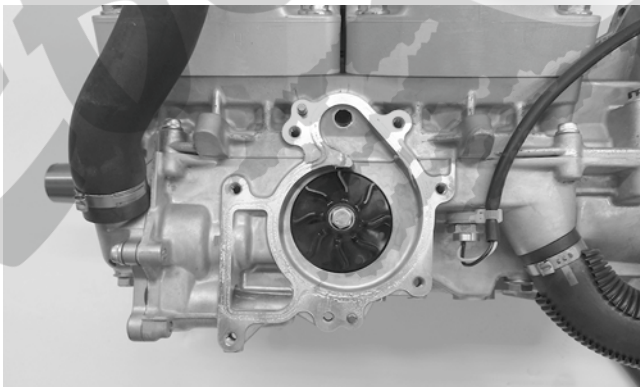

XM112

- Apply sealant to the crankcase seam; then install the alignment pins into the crankcase (if removed).

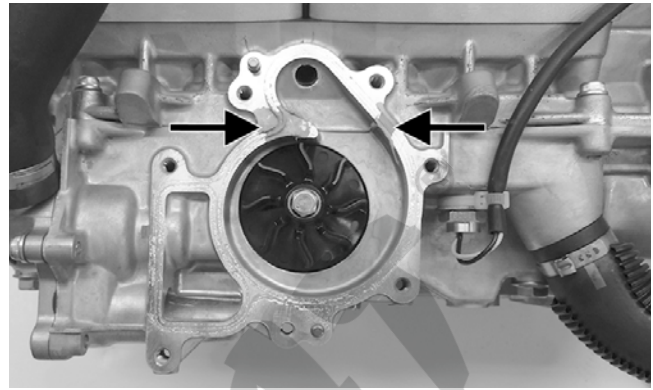

XM112A

- Position the O-ring into the water pump cover; then install the cover. Install the cap screws; then using the pattern shown, tighten to 96 in.-lb.

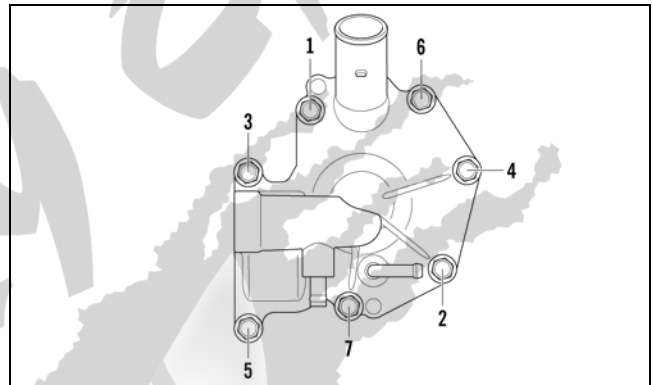

0742-257

- Secure the hoses to the water pump cover.

Pressure Testing Engine

■NOTE: To pressure test the engine, use Engine Leak-Down Test Kit.

Liquid Cooling System

The liquid cooling system consists of heat exchangers, water pump, coolant temperature sensor, and thermostat. The system should be inspected for leaks or damage whenever an overheating problem is experienced.

DRAINING COOLING SYSTEM

- Remove the access panels; then disconnect the hood harness and remove all screws securing the hood. Remove the hood.
- With the engine cool, remove the coolant cap; then using a suitable coolant vacuum pump, remove as much coolant as possible from the coolant tank.



XM213

3. Remove all springs securing the expansion chamber; then with the expansion chamber removed, loosen the clamp securing the lower coolant hose behind the engine. Remove as much coolant as possible using the coolant vacuum pump.



XM209A

■NOTE: Raising the rear end of the snowmobile will aid in removing all coolant from the heat exchangers.

4. Once the coolant has completely drained, secure the lower coolant hose using the existing clamp.

FILLING COOLING SYSTEM

1. Elevate the front of the snowmobile 30-35 cm (12-14 in.).
2. Remove the coolant tank cap and check coolant level. The coolant tank should be filled to the coolant level line.

Cooling System Schematic

The following schematic is representative of the different styles of cooling systems in the Arctic Cat snowmobiles. Some components may vary from model to model; therefore, the technician should use discretion and sound judgment when servicing a particular cooling system.

3. Install the coolant tank cap; then start the engine. Run the engine at 3000-3500 RPM until the bottom heat exchangers become hot to the touch. Stop the engine and allow the system to cool.
4. Lower the front of the snowmobile and elevate the rear of the snowmobile 12-14 in. Repeat the procedures in step 3.
5. Check the coolant level. Add coolant as required to the coolant tank (coolant tank should be filled to coolant level line). Repeat procedure until coolant level stabilizes in the coolant tank.

CAUTION

The cooling system must be properly filled. If the system isn't properly filled, piston damage will occur.

■NOTE: If coolant is required, mix coolant for a temperature of -36°C (-34°F). Follow mixing recommendations of the manufacturer of the coolant.

INSPECTING COOLANT HOSES AND CLAMPS

All coolant hoses and connections should be checked annually for deterioration, cracks, and wear.

All coolant hoses and clamps should be replaced every four years.

INSPECTING THERMOSTAT

1. Inspect the thermostat for corrosion, wear, or spring damage.
2. Using the following procedure, inspect the thermostat for proper operation.
 - a. Suspend the thermostat in a container filled with water; then heat the water and monitor the temperature with a thermometer.
 - b. The thermostat should open at 30°C (86°F). Once the thermostat starts to open, remove the thermostat and allow it to cool down verifying it has returned to the fully closed position.

CAUTION

Never heat the thermostat to the fully open position or damage to the thermostat may occur.

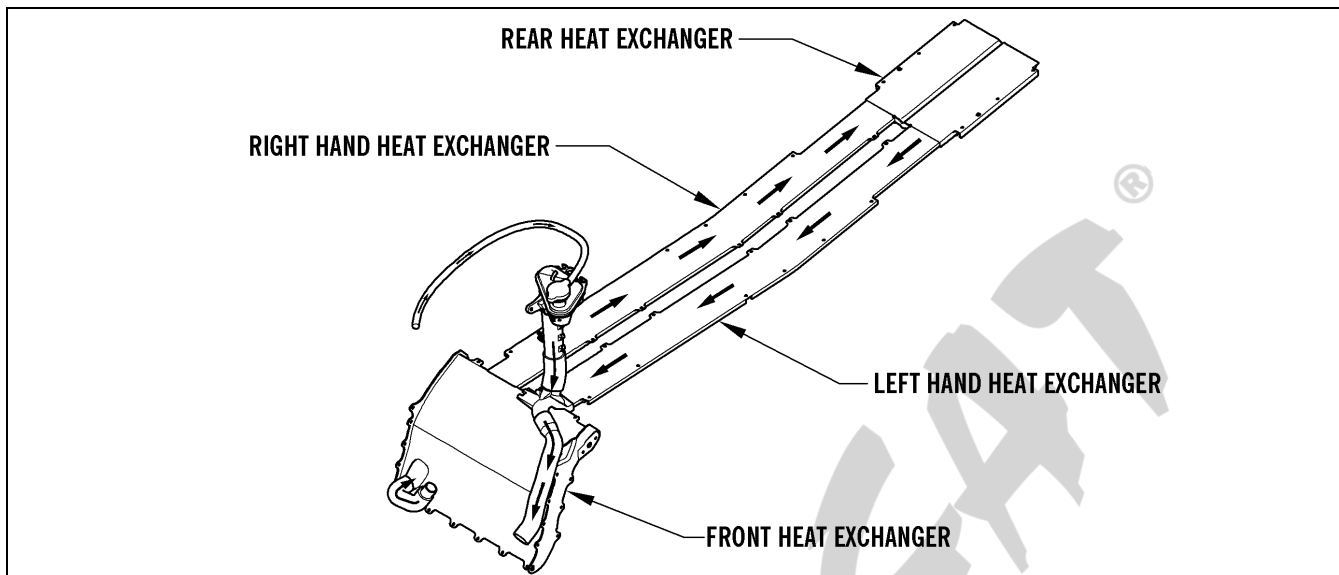

0747-869

Recoil Starter

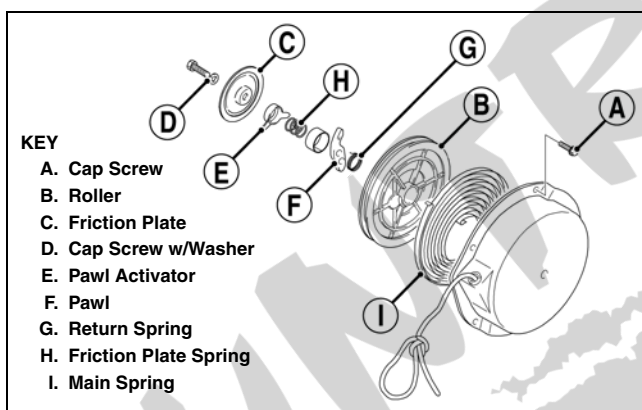

741-373B

REMOVING

1. Tie a slip-knot in the starter rope below the console and allow the rope to slowly retract against the starter case.
2. Remove the knot at the handle, remove the handle, and account for the handle cap; then thread the rope through the bushing in the console.
3. Remove the cap screws (A) securing the starter assembly to the magneto case; then remove the starter assembly.
7. Remove the main spring from the case by lifting the spring end up and out. Hold the remainder of the spring with thumbs and alternately release each thumb to allow the spring to gradually release from

DISASSEMBLING

⚠ WARNING

Always wear safety glasses and gloves when servicing the recoil starter.

1. Secure the recoil starter in a vise.

⚠ WARNING

During the disassembly procedure, continuous downward pressure must be exerted on the reel so it does not accidentally disengage and cause injury.

2. Rotate the roller (B) counterclockwise until the notch of the roller is near the rope guide in the case. Guide the rope into the notch and slowly allow the roller to retract until all recoil spring tension is released.

⚠ WARNING

Care must be taken when allowing the recoil roller to unwind. Make sure all spring tension is released before continuing.

3. While exerting downward pressure on the friction plate (C), remove the cap screw with washer (D).
4. Slowly release the friction plate and lift the plate with pawl activator (E) free of the recoil roller; then remove the pawl activator from the friction plate.
5. Remove the pawl (F) and the return spring (G); then remove the friction plate spring (H).
6. Carefully lift the roller free of the case making sure the main spring (I) does not disengage from the case. Account for the bushing.

⚠ WARNING

Care must be taken when lifting the roller free of the case.

the case.

■NOTE: Do not remove the main spring unless replacement is necessary. It should be visually inspected in place to save time.

8. Unwind the rope from the roller, untie the slip-knot, and remove the rope.

CLEANING AND INSPECTING

1. Clean all recoil starter components.
2. Inspect springs and pawl for wear or damage.
3. Inspect the roller and case for cracks or damage.
4. Inspect the center hub for wear, cracks, or damage.
5. Inspect the rope for breaks or fraying.
6. Inspect the main spring for cracks, crystallization, or abnormal bends.
7. Inspect the handle for damage, cracks, or deterioration.

ASSEMBLING

1. Hook the end of the main spring around the mounting lug in the case.
2. Insert the main spring into the case; then wind it in a counterclockwise direction until the complete spring is installed.

■NOTE: The main spring must seat evenly in the recoil case.

3. Insert the rope through the hole in the roller and tie a knot in the end; then wrap the rope counterclockwise around the roller leaving approximately 20 in. of rope free of the roller.
4. Apply low-temperature grease to the main spring and hub.
5. Align the hook in the end of the main spring with the notch in the roller.
6. Carefully slide the roller over the hub and engage the spring with the roller; then install the bushing.
7. Install the return spring making sure the short leg of the spring is properly installed in the hole in the roller; then install the pawl making sure the return spring is properly positioned in the notch of the pawl.
8. Slide the end of the rope through the rope guide of the case; then tie a slip-knot in the rope.
9. Apply a low-temperature grease to the friction plate. Place the pawl activator into position on the friction plate making sure the arms of the activator are properly positioned to the pawl.
10. Place the friction plate into position allowing it to rest on the friction plate spring; then install the cap screw w/washer (coated with blue Loctite #243) and thread the cap screw in until it contacts the friction plate.
11. Press down on the friction plate and tighten the cap screw to 15 ft-lb.

12. With 20 in. of rope exposed, hook the rope in the notch of the roller.
13. Rotate the roller four or five turns counter-clockwise; then release the rope from the notch and allow the rope to retract.
14. Pull the rope out two or three times to check for correct tension.

■NOTE: Increasing the rotations in step 13 will increase spring tension.

INSTALLING

1. Place the starter assembly into position against the magneto case.
2. Secure the starter with cap screws. Tighten to 96 in.-lb.

■NOTE: Before tightening the cap screws, slowly pull the recoil rope until the pawl engages; then tighten the cap screws centering the recoil against the magneto case.

3. Thread the rope through the bushing in the console; then install the handle and secure with a knot. Seat the cap.
4. Release the slip-knot in the rope.

Arctic Power Valve (APV) System

The Arctic Power Valve (APV) System adjusts the size of the exhaust ports to produce maximum horsepower on the top end while providing excellent low end power and increased touring fuel economy.

THEORY

Two-cycle engines and their exhaust systems are designed to produce maximum horsepower in a given RPM range. This RPM range will change according to how high (or low) the exhaust port is in relation to the cylinder. Engines designed for racing have a “high port” exhaust system and will produce more horsepower at higher RPM but only with the loss of low end power and overall fuel economy. “Low port” engines will produce maximum horsepower in the low RPM ranges and provide good mid-range fuel economy, but they sacrifice top end performance.

The APV system does not increase engine horsepower, but it does allow the engine to be designed for maximum top end horsepower without the losses associated with a “high port” exhaust system.

COMPONENTS

The main components of the APV system are the following.

- A. Lighting Coil
- B. Voltage Regulator/Rectifier
- C. ECM

- D. Servomotor
- E. Power Valve Cables
- F. Power Valves

Lighting Coil

The AC current generated by the lighting coil flowing to the regulator/rectifier is the power source for the APV system.

Voltage Regulator/Rectifier

The AC current from the power coil first enters the regulator/rectifier changing from AC current to DC current. Since the APV circuit cannot use pulsating DC current, it must be converted (by the condenser) to straight DC current. AC current enters the ECM from the lighting coil and is changed from AC to DC current by a rectifier located within the ECM.

ECM

The computer within the ECM has been programmed to cycle the power valves at 4500 RPM upon initial start-up. When this RPM is reached, DC current is routed to the servomotor by the ECM.

Servomotor

The servomotor consists of two circuits. One circuit is a DC circuit operating the DC motor within the servomotor, and the other is a potentiometer measuring the pulley position based on voltage.

The computer within the ECM has been programmed to operate the servomotor between a low and high voltage range. If voltage is not within the range, the computer will shut down the APV circuit. The computer will then make a total of three more attempts to cycle the power valves. If the correct voltage or pulley position isn't seen, the APV circuit is shut down and no more attempts will be made until the engine is shut down and restarted.

Exhaust Valve Cables

The exhaust valves are connected to the actuating cables and, along with the return springs, are contained inside the APV housing on the exhaust side of each cylinder. The other end of the actuating cable is connected to the servomotor.

OPERATION

At idle and low speed operation, the exhaust valves are held in the "low port" position by the return spring. When engine RPM reaches a predetermined point, the ECM will send a signal to the servomotor which cycles and pulls the exhaust valves into the mid-point. At another RPM, the ECM will send a signal to the servomotor which cycles and pulls the exhaust valves to the up or "high port" position.

If the servomotor cycles the exhaust valves as explained above, the exhaust valve circuit is operating satisfactorily. If the servomotor makes no attempt to open the valves or if the servomotor attempts to cycle the valves three times (then stops working), a problem exists and it must be corrected.

Servomotor Cycles Three Times

In this situation the ECM computer has been programmed with a voltage range (low and high) that the servomotor must operate within. If the servomotor is put under too much load, its resistance goes up and may exceed the range upper limit. It will then stop and attempt two more times. If the resistance still is too high, it shuts down.

If the servomotor is commanded to move but the potentiometer output voltage does not change, an error occurs and the check engine light will flash a trouble code.

Improper servomotor position sensing is normally caused by one or more of the following:

- A. Incorrect exhaust valve cable length (too long or too short).
- B. Exhaust valve cable(s) sticking, broken, or disconnected at pulley.
- C. Exhaust valves sticking.
- D. Exhaust valve spring(s) weak or broken.

Check each of the above probable causes in the order given to locate the problem of the servomotor cycling three times in succession; then shutting down.

Check for correct exhaust valve cable length specifications for model being worked on in this section.

Servomotor Makes No Attempt To Cycle

If when running the engine the servomotor makes no attempt to operate, this is caused by one or more of the following:

- A. Bad connection from the wiring harness and connector from the lighting coil to the ECM, or from the ECM to servomotor.
- B. ECM output to servomotor is too low.
- C. Servomotor failure.
- D. Blown fuse.
- E. Voltage Regulator/Rectifier.

■NOTE: For testing individual APV system components, see the Electrical Systems section.

MAINTENANCE

The APV system requires only periodic cleaning and cable adjustment. The cables should be checked every 2600 miles and adjusted as necessary.

CABLE ADJUSTMENT

Proper cable adjustment is critical to the operation of the APV system. To check the cable adjustment, use the following procedure.

1. Using a small needle-nose pliers, remove the servomotor cable holder.

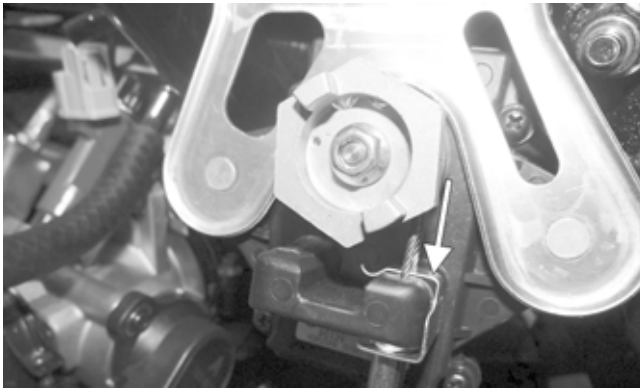

PC187A

2. Pull the cable housings down and out of the servomotor; then slide each cable end out of the slot of the pulley.



PC134

■NOTE: Ensure the exhaust valves are free to move.

3. While holding the cable housing firmly, pull the cable as far out as it will go; then release. Repeat three to four times. The cable/exhaust valve should move freely without binding. If the cable/exhaust valve does not move freely, the exhaust valve assembly will need to be removed for further inspection.

■NOTE: When measuring the cables, they are to be routed and as close to their installed position as possible.

4. While holding the cable housing, lightly pull on one cable end to remove any slack; then measure the amount of exposed cable from the cable housing to the end of the cable.

■NOTE: The two cable measurements must be equal in length or less than 0.5 mm (0.020 in.) difference in length from each other.

■NOTE: Repeat steps 3 and 4 for each cable; then compare the measurements to the APV Cable Length chart in the General Information section. The measurements must be within the specifications from the chart. If the measurements are within specifications, no adjustment is necessary (proceed to step 7). If they are not within specifications, proceed to step 5.

5. Loosen the jam nut on the cable to be adjusted; then using the adjusting nuts, lengthen or shorten the housing as needed.

6. Once the proper length has been attained, hold the adjusting nut in place and tighten the jam nut securely.

7. Insert the servomotor cable ends into the slot in the pulley. Secure the cables with the holder.

■NOTE: If the pulley was removed from the servomotor, align the space between the two cable slots with the mark on the shaft of the servomotor. Tighten the nut to 35 in.-lb.

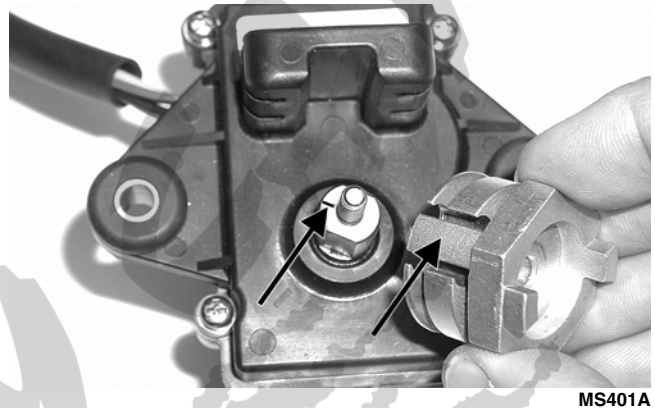

MS401A

CAUTION

Never attempt to remove or install the pulley jam nut with the pulley unsecured or damage to the servomotor will occur.

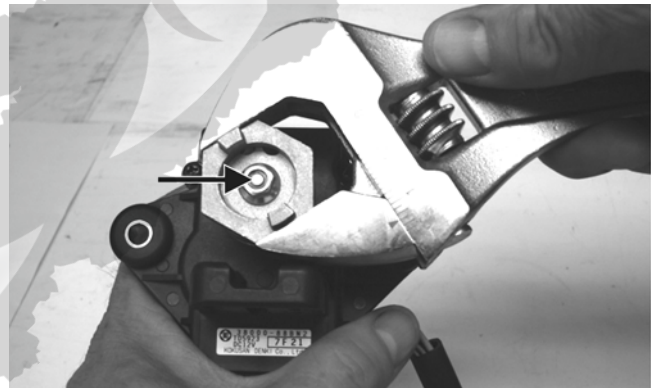

FZ087A

REMOVING/DISASSEMBLING

■NOTE: To avoid a parts mix-up, only remove one valve assembly at a time from the engine.

1. Remove the exhaust valve assembly from the engine.

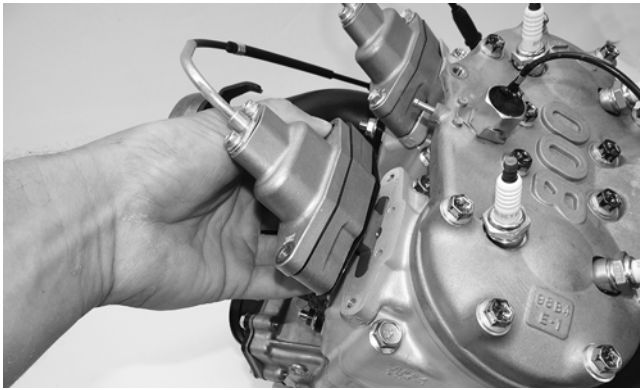

XM017

2. Remove the retaining screw securing the exhaust valve to the valve stopper.

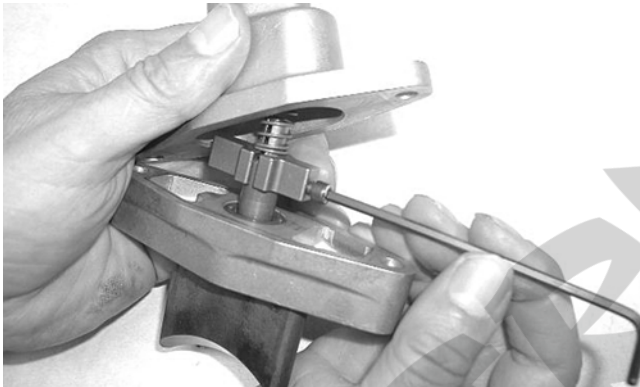

FC112

3. Hold the valve stopper securely and pull the cable back and up until it clears the top of the stopper; then slowly release the cable and remove it from the valve stopper.



FC113

Cleaning and Inspecting

1. Remove all carbon deposits with solvent and a soft abrasive such as a Scotch-Brite pad.
2. Inspect all parts for nicks, burrs, or other signs of unusual wear.

Replacing Oil Seal

1. Carefully pry the seal up from beneath taking care not to damage the valve plate.
2. Install the new seal using an appropriate-sized seal driving tool.

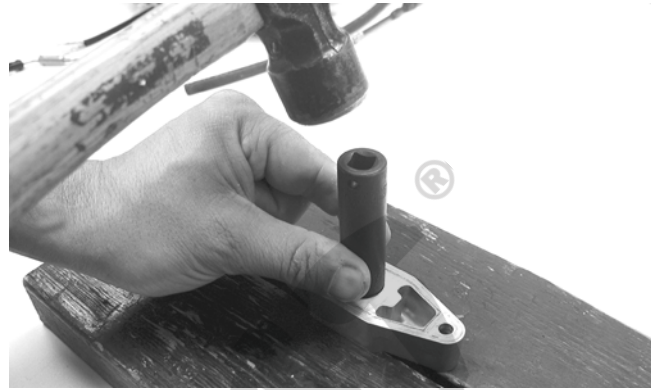

FC117

ASSEMBLING/INSTALLING

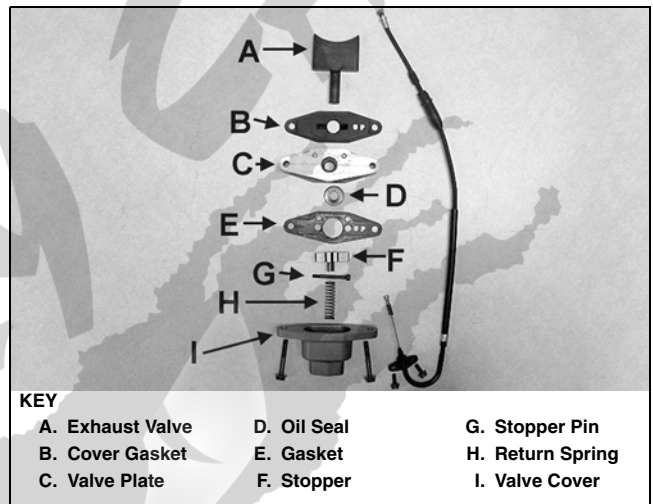

FC111A

1. Slide the return spring over the end of the actuating cable.

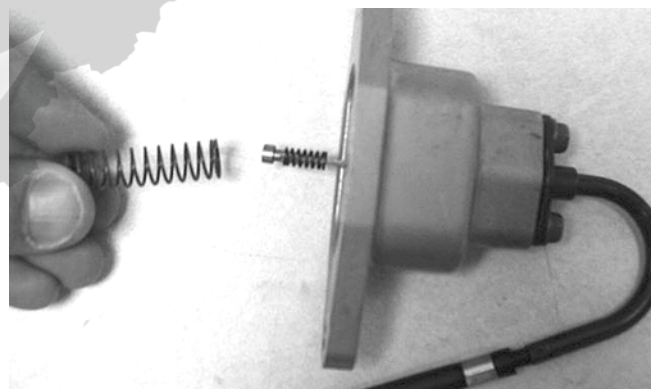

FC114

■NOTE: Make sure that the small cable end spring stays in place at the end of the cable.

2. With the cover gasket properly positioned, place the valve stopper on the cable end and slide it down until the cable end is inside the stopper.

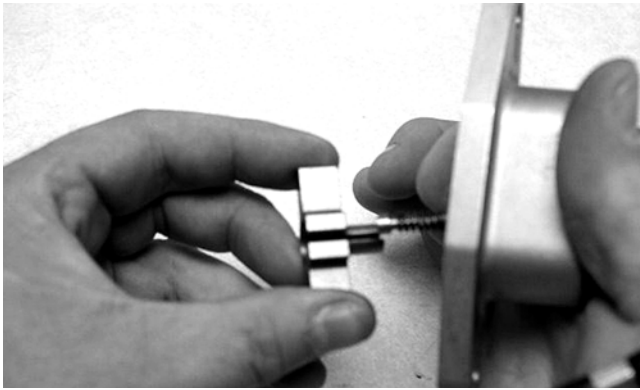

FC113

- With the valve plate gasket properly positioned, slide the exhaust valve through the valve plate and insert it into the valve stopper. Secure with the retaining screw. Tighten to 48 in.-lb.

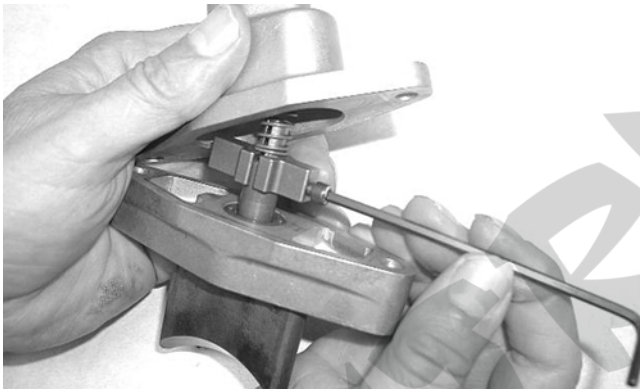

FC112

■**NOTE:** Note that the exhaust valve gaskets are directional and must be installed correctly.

- Slide the exhaust valve assembly into the cylinder.

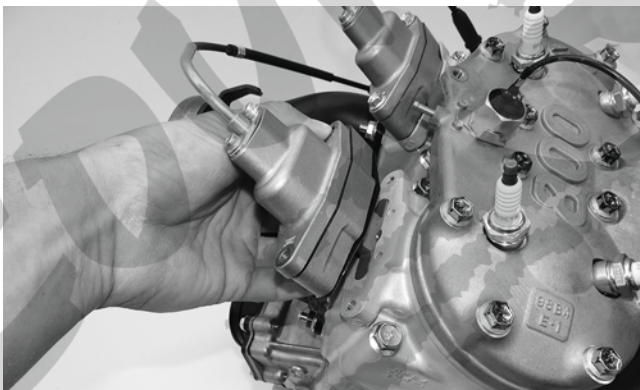

XM017

- Place the valve cover into position on the engine. Secure with two cap screws. Tighten to 96 in.-lb.

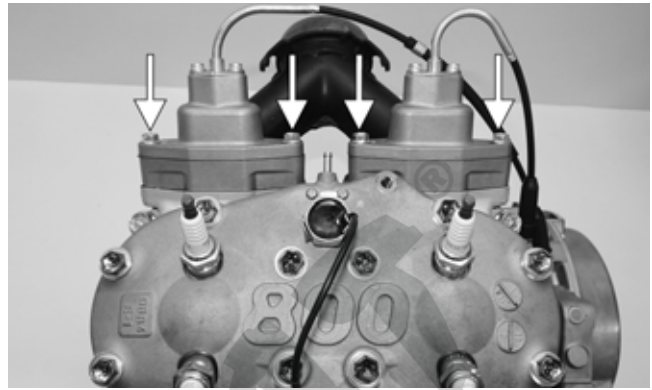

XM024A

- Perform steps 5-8 in Cable Adjustment in this subsection.

TROUBLESHOOTING

The APV system has a self-testing mode built in. Every time that the engine is started, the servomotor will cycle once. The ECM monitors the voltages at the servomotor during this cycle to assure they are within operational tolerances.

If all voltages are within tolerance, the system is ready for operation. If the voltages are not within tolerance, the servomotor will cycle two more times. If the voltages remain out of tolerance, the system will not operate.

For example, if the headlight and taillight are disabled, the ECM will sense a high voltage condition and activate the fail-safe mode. Adding more than 4 amps of accessories will create a low voltage condition and activate the fail-safe mode.

The fail-safe mode is an ECM operated engine RPM limiter. When activated, the fail-safe mode will be seen as an immediate loss of engine horsepower.

Problem: Engine loses power; no top end	
Condition	Remedy
1. Exhaust valves sticking in down position	1. Remove carbon deposits, burrs, etc.
2. Cables adjusted too long	2. Inspect—adjust
3. Regulator/Rectifier output voltage out of tolerance	3. Inspect—replace Regulator/Rectifier/stator
Problem: Poor acceleration; hesitation	
Condition	Remedy
1. Exhaust valve sticking in up position	1. Remove carbon deposits, burrs, etc.—inspect/replace return spring
2. Cables adjusted too short	2. Inspect—adjust
3. Regulator/Rectifier output voltage out of tolerance	3. Inspect—replace Regulator/Rectifier/stator

Exhaust Controlled Timing (ECT) System

These models are equipped with the Exhaust Controlled Timing (ECT) system utilizing an exhaust pipe temperature sensor.

■NOTE: The engine has a three-stage exhaust valve system. The stages are closed, mid-open, and full-open. These models have a designated RPM of 4500 at which the system is synchronized and checked by the ECM for proper operation occurring once each time the engine is started.

This system automatically adjusts the ignition timing to provide maximum performance through a variety of operating conditions. The ECM receives input on engine RPM (demand) and exhaust temperature (engine condition) and adjusts the ignition timing accordingly. This system is not adjustable and is maintenance free.

If a system fault is suspected, use an ohmmeter to check continuity of the exhaust pipe temperature sensor located in the expansion chamber. A reading of either 0 ohm or infinity indicates a failed sensor.

■NOTE: A disabled ECT system WILL NOT cause engine damage; however, a failed ECT system will have slower throttle response and may produce slightly less top-end performance.

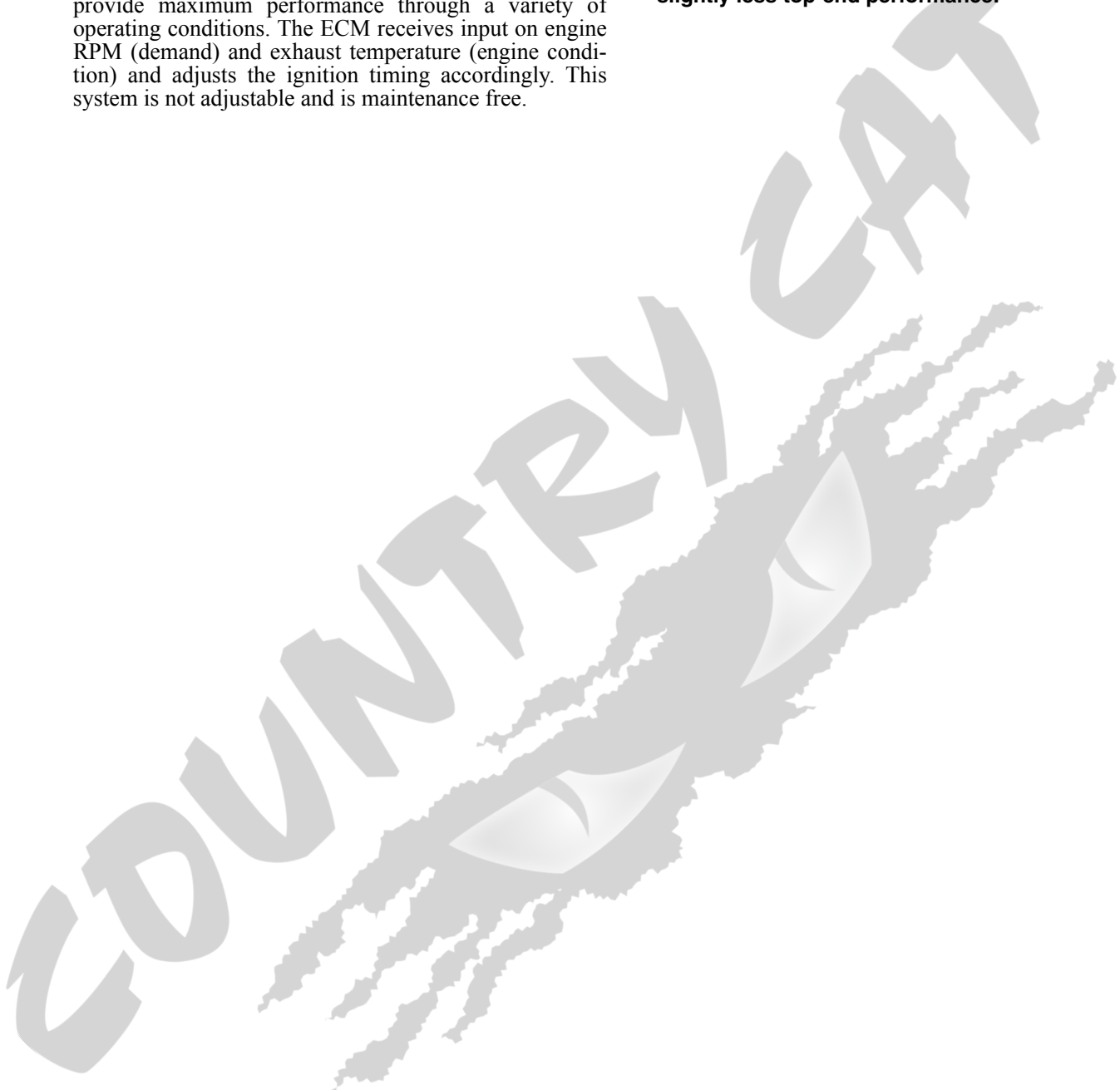

Fuel Systems

This section has been organized for servicing the fuel systems; however, some components may vary from model to model. The technician should use discretion and sound judgment when removing/disassembling and assembling/installing components.

Whenever any maintenance or inspection is made on the fuel system where fuel leakage may occur, there should be no welding, smoking, or open flames in the area.

■ **NOTE: Whenever a part is worn excessively, cracked, or damaged in any way, replacement is necessary.**

SPECIAL TOOLS

A number of special tools must be available to the technician when servicing the fuel systems.

Description	p/n
CATT II	0554-023
EFI Analyzer	0744-049
EFI Diagnostic System Manual	2257-850
EFI Diagnostic System Manual (Instructions)	2259-020
Fluke Model 77 Multimeter	0644-559
Fuel Hose Clamp Tool	0644-545
EFI Fuel Pressure Test Kit	0644-587
Vacuum Test Pump	0644-131
Fuel Pump Installation Tool Kit	0744-074
Laptop Diagnostic Test Kit	0744-050
Laptop Diagnostic Tool	0744-060
Oil Injection Usage Tool	0644-007

■ **NOTE: Special tools are available from the Arctic Cat Service Parts Department.**

EFI System

INTRODUCTION

The Arctic Cat EFI System operates off a series of coils located on the stator and is made up of the following components.

1. An engine control module (ECM) calculates input from sensors (exhaust temperature sensor, air temperature sensor, coolant temperature sensor, throttle position sensor, ignition timing sensor, barometric pressure sensor, and a knock sensor) to provide the engine with the correct fuel mixture and timing for optimum operation.
2. Charge coils (1 and 2), located on the stator, provide AC voltage to the ECM/regulator/rectifier where AC voltage is converted to DC voltage.
3. A fuel pump coil located on the stator operates the low voltage, high output fuel pump. At cranking speed, the high output fuel pump provides enough fuel to charge the fuel rail.
4. An injector coil located on the stator provides the injectors with DC voltage for operation through the ECM.

5. A lighting coil located on the stator plate provides output to the regulator/rectifier (8000) to operate accessories and the lighting system.

FLOODED ENGINE

If the engine should become flooded, set the brake lever lock, compress the throttle lever to the full-open position, and crank the engine over until it starts and clears itself. Release the brake lever lock.

FUEL SYSTEM

The fuel is first drawn into the electric fuel pump through multiple pick-up valves and hoses. The fuel is then routed through a high-pressure fuel hose to the fuel rail.

The fuel pressure is maintained in the fuel rail by the fuel regulator. With the fuel pressure maintained at a constant psi, the ECM evaluates the information it receives from the electrical sensors and opens the injectors for precise periods of time (pulse widths) to meet engine demands.

■ **NOTE: The entire EFI system depends on all coils functioning properly on the stator.**

Individual Components

ECM

The ECM is the brain of the EFI system. It uses sensor inputs to determine the correct fuel/air ratio for the engine given the existing conditions of altitude and temperature.

If any of the sensors should fail while the engine is running, the ECM will sense a problem and go into a “fail safe” mode. This is an over-rich condition and will greatly reduce performance. However, the engine will be protected from a possible lean condition and engine damage.

The ECM is equipped with a self-diagnostic system utilizing the service icon in the speedometer/tachometer and remains illuminated when a problem exists with any of the sensors. The technician can determine the problem sensor by reading the code shown on the readout screen and applying it to the ECM Diagnostic Codes chart (see Self-Diagnostic System/Codes in this section).

■ **NOTE: The ECM cannot be repaired.**

If the ECM is not receiving current from one of the output coils on the stator, that circuit will not operate. Coils on the stator are the charge coils operating the ECM, the injector coil which operates the injectors, the fuel pump coil which operates the fuel pump, and the lighting coil/chassis control unit operating all accessories and the lighting system.

■ **NOTE: On the 4000, the ECM is coded with a letter (A-B-C). When replacement of the ECM is necessary, the ECM must be replaced with an ECM of the same letter.**

■ **NOTE: On the 8000, the ECM is coded with symbols (■-●-▲). When replacement of the ECM is necessary, the ECM must be replaced with an ECM of the same code.**

Removing

1. Remove the expansion chamber.
2. Remove the two torx-head screws securing the rear portion of the ECM heat shield; then remove the shield.
3. Disconnect the wire harness leads from the ECM; then remove the two cap screws securing the ECM. Remove the ECM.

Installing

1. Secure the ECM to the chassis using the existing cap screws; then connect the wiring harness to the ECM.
2. Secure the front of the ECM heat shield into the tabs; then secure the back of the ECM heat shield using the existing torx-head screws. Install the expansion chamber.

■NOTE: Make sure all connectors are clean and tight. Apply dielectric grease to all connectors.

AIR TEMPERATURE SENSOR

This sensor detects air temperature entering the air silencer and engine. The ECM sends current to this sensor, and (depending on the temperature) the sensor will pass a certain amount of current through the sensor to ground. The ECM measures how much current passes through the sensor to ground. From this measurement, the ECM determines the air temperature and calculates the fuel/air mixture ratio. Resistance will drop as the temperature rises.

Removing

1. Disconnect the wiring harness from the air temperature sensor.
2. Using a flat-blade screwdriver, pry the sensor end to end to remove it from the air silencer. Account for two push pins.

Installing

1. Place the sensor into position in the air silencer and secure with push pins.
2. Connect the wiring harness to the air temperature sensor. Secure the sensor wires with cable ties so they do not rub on any other components.

COOLANT TEMPERATURE SENSOR

This sensor detects coolant temperature. The ECM measures the current flow through the sensor to ground. From this measurement, the ECM can determine the engine coolant temperature and calculate the correct fuel/air mixture ratio.

■NOTE: If the coolant temperature rises above 75° C (167° F), the temperature sensor starts to richen the fuel mixture. At this time, the check engine light will flash constantly. Once the engine coolant temperature reaches the specified temperature 90° C (194° F), the temperature sensor will signal the ECM to go into the rich mode to protect the engine while overheating. At this time, the check engine light will be constantly on.

THROTTLE POSITION SENSOR

This sensor is a potentiometer (essentially, a resistor). This sensor transforms the throttle-valve position into output voltage to the ECM. In addition, the sensor detects the opening or closing speed of the throttle valve and feeds that rate of voltage change to the ECM.

■NOTE: The input from the throttle position sensor is one of the main inputs for the ECM calculation of fuel/air mixture ratio.

IGNITION TIMING SENSOR

This sensor is triggered by teeth precisely mounted to the flywheel flange. Each time a tooth rotates past the sensor, a signal is sent to the ECM. From this signal, the ECM determines ignition and injection timing and RPM.

BAROMETRIC PRESSURE SENSOR

This sensor is part of the ECM. Its purpose is to sense atmospheric pressure. From this information, the ECM determines the correct fuel/air mixture ratio.

■NOTE: The sensor is not replaceable. If it should fail, the ECM must be replaced.

FUEL INJECTORS

A fuel injector is an electromagnetic injection valve controlled by a signal from the ECM. The coil used in the injector is a high-pressure resistance type. The ECM determines the optimum fuel injection time and duration based on signals from the sensors.

When voltage is sent to the fuel injector, it energizes the coil and opens the needle valve, thereby injecting fuel. Because the fuel pressure (between fuel line and manifold) is kept constant, the amount of fuel injected is determined by the duration of time the valve is open and manifold pressure.

8000

The injectors are coded with symbols (■-●-▲) and are color-coded yellow and green. When replacement of a fuel injector is necessary, the injector must be replaced with an injector of the same code symbol and color.

CAUTION

Do not replace an injector with one of a different code symbol. Severe engine damage may occur.



SNO-738

Removing

WARNING

Since the fuel supply hose may be under pressure, remove it slowly to release the pressure. Place an absorbent towel around the connection to absorb gasoline; then remove the hose slowly to release the pressure. Always wear safety glasses when removing the fuel hoses.

1. Loosen the clamp securing the fuel supply hose to the fuel rail; then remove the hose from the fuel rail.
2. Disconnect the wiring harness from each injector.
3. Remove the screws securing the injector hold-down plate to the throttle body assembly; then remove the plate from the injectors.
4. Remove the fuel injectors from the throttle body/intake manifold assembly.

Installing

1. Apply a light coat of oil to all O-rings; then install the upper and lower O-rings onto each injector.
2. Install the injectors into the throttle body assembly.
3. Place the injector hold-down plate into position on top of the injectors and secure with two screws.
4. Connect the fuel delivery hose to the fuel rail and secure with a clamp.

■NOTE: When securing the fuel delivery hose, position the clamp as shown.

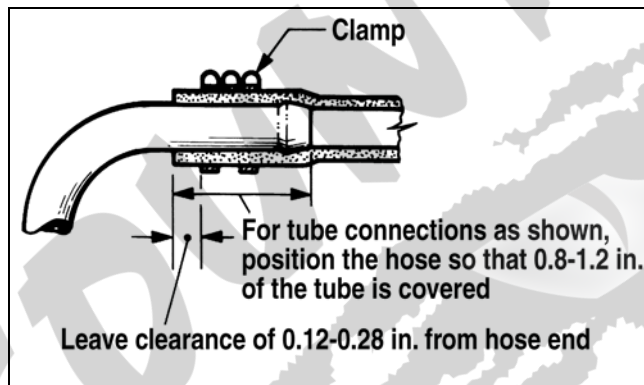

729-325A

5. Connect the wiring harness to the injectors.

6000



CWI-106

Removing

1. With both access panels, hood, seat, and the gas tank removed, remove the nuts securing the fuel rail to the back of the cylinders.
2. Pull the fuel rail with the injectors from the cylinders and disconnect the wiring harness from each injector.
3. Carefully remove the injector from the fuel rail. Account for both gaskets.

Installing

■NOTE: If installing new injectors, be sure to leave the tag on the injector(s) as the codes A and B and the cylinder (MAG or PTO side) must be entered using the CATT II Tool.

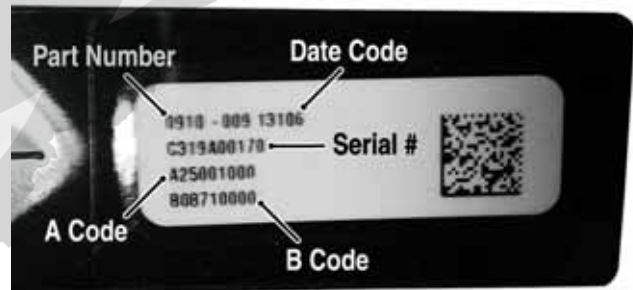

SNO-1235A

1. Lightly oil the injector seals using the C-TEC2 engine oil; then carefully install the injector into the fuel rail.
2. Connect the wiring harness to the injectors; then install the fuel rail with injectors into the back of the cylinders. Secure using the existing nuts. Tighten to 102 in-lb.

4000

The injectors are coded with letters (A-B-C). When replacement of a fuel injector is necessary, the injector must be replaced with an injector of the same letter.

CAUTION

Do not replace an injector with one of a different code letter. Severe engine damage may occur.



XM-281

Removing

WARNING

Since the fuel supply hose may be under pressure, remove it slowly to release the pressure. Place an absorbent towel around the connection to absorb gasoline; then remove the hose slowly to release the pressure. Always wear safety glasses when removing the fuel hoses.

1. Loosen the clamp securing the fuel supply hose to the fuel rail; then remove the hose from the fuel rail.
2. Disconnect the wiring harness from each injector.
3. Remove the screws securing the injector hold-down plate to the throttle body assembly; then remove the plate from the injectors.
4. Remove the fuel injectors from the throttle body/intake manifold assembly.

Installing

1. Apply a light coat of oil to all O-rings; then install the upper and lower O-rings onto each injector.
2. Install the injectors into the throttle body assembly.
3. Place the injector hold-down plate into position on top of the injectors and secure with two screws.
4. Connect the fuel delivery hose to the fuel rail and secure with a clamp.

■NOTE: When securing the fuel delivery hose, position the clamp as shown.

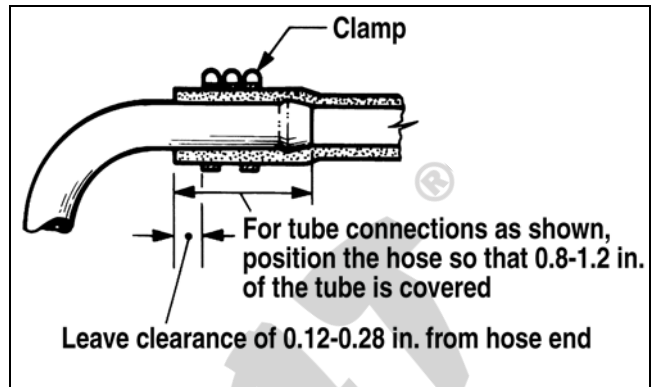

729-325A

5. Connect the wiring harness to the injectors.

FUEL PRESSURE REGULATOR

The fuel pressure regulator maintains the fuel pressure at a constant specified level.

EXHAUST TEMPERATURE SENSOR

This platinum, thin-film sensor detects the exhaust air temperature in the exhaust system. The ECM sends current to this sensor, and (depending on the temperature) the sensor will pass a portion of that current to ground. The ECM measures how much current passes through the sensor to ground. From this measurement, the ECM determines the exhaust air temperature and adjusts the fuel, ignition timing, and APV calibration. Resistance will increase as the temperature rises.

FUEL PUMP CIRCUIT

The fuel pump and its circuit are provided with current from the fuel pump coil on the stator. For this circuit to function correctly, five components must be properly functioning. Check the following components before considering the fuel pump assembly to be defective.

- A. Fuel pump coil - see coil test procedure.
- B. Emergency stop switch and ignition switch must be ON.
- C. Fuel pump - see fuel pump test procedure.
- D. Wiring harness and connectors - clean the connectors and test the harness.
- E. ECM.

KNOCK SENSOR

This sensor controls engine knock or detonation. The knock sensor assesses structure borne noise (vibrations) caused by rapid pressure rises (detonation) in either cylinder and performs calibration adjustments to the necessary cylinder via the ECM limiting damage to internal engine components. Detonation can be caused by many variables including poor fuel quality, lean operating conditions, or modified engine components/systems.

Self-Diagnostic System/ Codes (4000)

INTRODUCTION

The Diagnostic Code Alarm is controlled by the ECM. If a code illuminates while the engine is running, the ECM is receiving input that is outside of its established parameters.



FZ003E

Code	Trouble
2	Failure in injector(s).
4	Open or short circuit in barometric pressure sensor.
5	Open or short circuit in intake air temperature sensor.
6	Open or short circuit in water temperature sensor.
7	Open or short circuit in throttle position sensor.
12	Failure in ignition coils.

Self-Diagnostic System/ Codes (6000)

■NOTE: For testing the 6000 EFI system, refer to the CATT II manual.

INTRODUCTION

The Diagnostic Code Alarm is controlled by the ECM. If a code and the word ALARM illuminates while the engine is running, the ECM is receiving input that is outside of its established parameters.



CWI-105A

Code	Trouble
P0112	Intake air temp sensor 1 circuit low.

Code	Trouble
P0113	Intake air temp sensor 1 circuit high
P0117	Coolant temp sensor 1 circuit low.
P0118	Coolant temp sensor 1 circuit high.
P0122	Throttle position sensor circuit low.
P0123	Throttle position sensor circuit high.
P0261	Cylinder 1 injector circuit low.
P0264	Cylinder 2 injector circuit low.
P0324	Knock control system error.
P0327	Knock control 1 circuit low.
P0328	Knock control 2 circuit high.
P0351	Ignition coil (A) primary/secondary.
P0352	Ignition coil (B) primary/secondary.
P0545	Exhaust temp sensor circuit low.
P0546	Exhaust temp sensor circuit high.
P1000	Oil pump flow not programmed.
P1001	Injector 1 offset not programmed.
P1002	Injector 2 offset not programmed.
P1003	Oil pump outlier.
P1004	ISC outlier.
P1005	Regulator voltage circuit low.
P1006	Regulator voltage circuit high.
P1007	Fuel pump circuit low.
P1008	Fuel pump circuit high.
P1009	Speed sensor malfunction.
P1261	Injector circuit/open - Cylinder 1b.
P1264	Injector circuit/open - Cylinder 2b.
P1324	Knock Control System Activated
P1329	Knock sensor loose detection.
P1636	Crank angle sensor circuit.
P1639	Exhaust valve position sensor circuit low.
P1640	Exhaust valve position sensor circuit high.
P1645	Exhaust valve system malfunction.
P1646	Exhaust valve actuator self-cleaning open error.
P1647	Exhaust valve actuator short error.
P1755	Engine RPM sensor circuit malfunction.
P2228	Barometric pressure sensor (A) circuit low.
P2229	Barometric pressure sensor (A) circuit high.
P3001	Control module improper shutdown.
U1000	Vehicle not registered or invalid PIN entered.
U1001	Vehicle not registered and vehicle limits enabled.
U0155	Lost communication with the ECM

The fuel system and the ignition system remain two separate systems. In a no-start situation, first determine if the problem is caused by lack of spark or by a fuel delivery problem or by an internal engine condition (low cylinder compression for example).

Once the problem area has been determined, check the components involved using the Fluke Model 77 Multimeter or the EFI Analyzer depending on the test being made.

Self-Diagnostic System/ Codes (8000)

■NOTE: For testing the 8000 EFI system, refer to the EFI Diagnostic System Manual with Laptop Diagnostic Tool and Laptop Diagnostic Test Kit.

INTRODUCTION

The Service Icon is controlled by the ECM. The icon should illuminate each time the engine is started, and it should go out after a few seconds. If the icon stays illuminated while the engine is running and a code is displayed on the readout screen, the ECM is receiving input that is outside of its established parameters.

Deluxe Gauge



FZ001D

Standard Gauge



FZ003B

Code	Trouble
2	Failure in injector(s).
4	Open or short circuit in barometric pressure sensor circuit.
5	Open or short circuit in intake air temperature sensor circuit.
6	Open or short circuit in water temperature sensor circuit.
7	Open or short circuit in throttle position sensor circuit.
12	Failure in ignition coil(s).
16	Incorrect adjustment/failure in APV cable.
17	Failure in exhaust temperature sensor circuit.
18	Failure in servomotor.
21	Open or short circuit and/or loose knock sensor circuit.
OCTN	Low octane gasoline.

■NOTE: For codes ECM 16 and ECM 18, see Servomotor/Potentiometer Test in the Electrical Systems section.

The fuel system and the ignition system remain two separate systems. In a no-start situation, first determine if the problem is caused by lack of spark or by a fuel delivery problem or by an internal engine condition (low cylinder compression for example).

Once the problem area has been determined, check the components involved using the Fluke Model 77 Multimeter or the EFI Analyzer depending on the test being made.

Fuel Pressure Regulator

- Using the Fuel Pressure Test Kit, connect the tester to the regulator fuel inlet.

■NOTE: A short piece of 3/8 in. I.D. hose will be needed to make the above connections.

- Pressurize the regulator to 28-31.3 psi. Turn the pressure tester shut off valve to the OFF position. Observe the gauge for several minutes and note any loss of pressure. If pressure begins to drop, the cause may be a ruptured diaphragm, worn spring, or leaking valve. If the regulator fails to build or maintain pressure, replace the regulator.

■NOTE: If the pressure drops, check the hose connections to ensure no leaks exist.

Throttle Body Assembly

REMOVING

■NOTE: The expansion chamber, shock mount bracket support and air silencer must be removed for this procedure (see the Engine-Related Items section).

- Disconnect the wiring harness from each injector and from the throttle position sensor.
- Remove the coolant hoses from the throttle body assembly and plug them to prevent leakage.
- Remove the fuel supply hose from the fuel rail.

WARNING

Since the fuel supply hose may be under pressure, remove it slowly to release the pressure. Place an absorbent towel around the connection to absorb gasoline; then remove the hose slowly to release the pressure. Always wear safety glasses when removing the fuel hoses.

- Loosen the flange clamps.
- Remove the oil pump control rod.
- Slide the throttle body assembly out of the flanges; then loosen the jam nut securing the throttle cable and remove.
- Remove the throttle body assembly.

INSTALLING

- Attach the throttle cable to the throttle body; then secure with jam nut. Secure the coolant hoses to throttle body assembly.
- Place the throttle body assembly into position. Make sure the flanges and boots are positioned properly. Secure with flange clamps.
- Connect the oil pump control rod.
- Connect the fuel supply hose to the fuel rail.

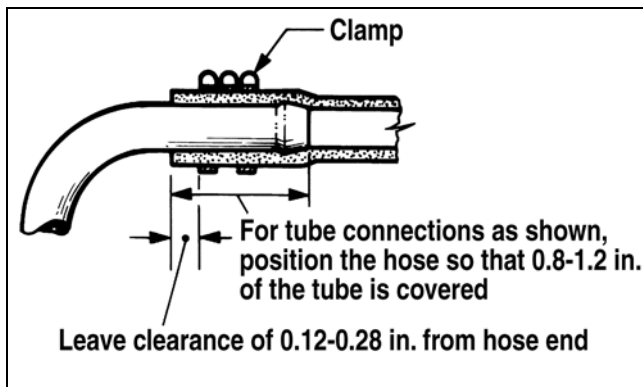

729-325A

5. Connect the wiring harness to each injector and throttle position sensor.

CAUTION

Verify the oil pump rod linkage is properly installed or damage to the engine will occur.

■NOTE: Install the air silencer, shock mount bracket support, and the expansion chamber (see the Engine-Related Items section).

6. Place the rear of the snowmobile on a shielded safety stand and start the engine without touching the throttle. It may idle slowly and stop. Restart using the same procedure until the engine starts and builds RPM on its own.

CAUTION

When installing the throttle bodies, make sure the gasoline hose is properly routed to avoid premature wear and/or contact with exhaust components.

7. Check the cooling system and adjust the throttle cable as necessary.

Throttle Cable

REMOVING

1. Loosen the throttle cable from the bracket; then remove the throttle cable from the pulley on the throttle body lever shaft.
2. Remove the cable ties securing the throttle cable.
3. Remove the throttle cable ends from the throttle lever and from the throttle control housing.

INSTALLING/ADJUSTING

1. Install the throttle cable into the throttle control assembly making sure the cable snaps into place.
2. Install the throttle cable end on the throttle lever.
3. Route the throttle cable from the throttle control assembly to the throttle body assembly and oil-injection pump; avoid any sharp bends or moving components.
4. Attach the throttle cable to the pulley on the throttle body shaft.

5. Secure the throttle cable to the handlebar and steering post with cable ties.
6. Adjust the throttle cable tension by turning the jam nuts in the appropriate direction until 0.030-0.060 in. free-play exists in the throttle lever and the butterfly completely opens and closes. Tighten the jam nuts securely.

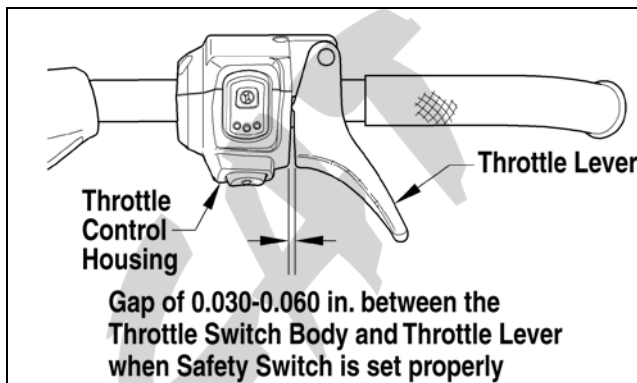

741-518A

CAUTION

Compress the throttle control lever to ensure free movement. If the throttle cable sticks or binds, correct the problem before starting the engine.

7. Synchronize the oil-injection pump.

Fuel Filter (6000)

■NOTE: The fuel filter should be replaced every 5000 miles.

WARNING

Since the fuel supply hose may be under pressure, remove it slowly to release the pressure. Place an absorbent towel around the connection to absorb gasoline; then remove the hose slowly to release the pressure. Always wear safety glasses when removing the fuel hoses.

■NOTE: Before removing the fuel filter, take note of the filter inlet and outlet for installing purposes.

REMOVING

1. Remove the right-side access panel to access the fuel filter; then remove the gasoline hose from the two routing clamps on the front right spar.

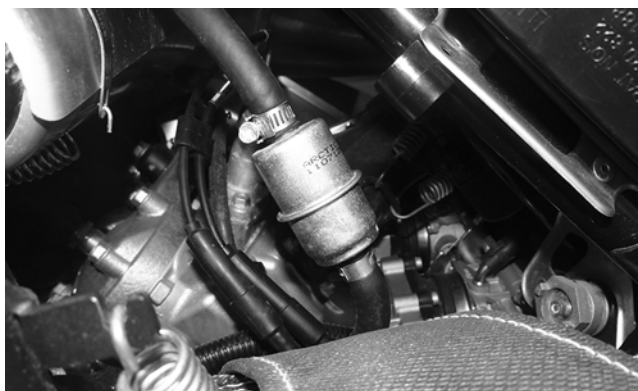

XM282

- Remove the hose clamps; then slowly remove the gasoline hoses from the fuel filter. Dispose of the excess fuel from the filter properly.

■NOTE: The fuel pump side hose clamp should be retained and the fuel rail side hose clamp should be discarded.

- Inspect the hoses for any signs of cracking, cuts, or wear points. Replace if necessary.

INSTALLING

CAUTION

When installing the gasoline hoses and clamps make sure the hoses are pressed up against the filter and the clamps are not installed over the end of the hose or the barb on the filter.

- Place existing hose clamp (fuel pump side) and a new hose clamp (fuel rail side) on the gasoline hoses; then with the fuel pump inlet and outlet oriented correctly, press the gasoline hoses onto the filter making sure they are fully pressed on.
- Secure the gasoline hoses using the clamps making sure there is no more than 9 mm between the filter and the clamps. Tighten the fuel pump side hose clamp to 14 in.-lb.
- Use Fuel Hose Clamp Tool to make sure the fuel rail side hose clamp is tight by crimping the clamps until the two clamp areas touch.

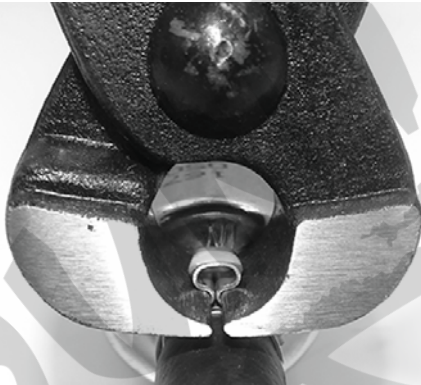

XM282

- Start the engine and inspect the fuel hoses and filter for any signs of leaks.
- Close the right-side access panel.

Fuel Pump

TESTING

- Remove the seat assembly; then remove the upper and lower console panels.
- Disconnect the gasoline hose connector hose from the outlet of the fuel pump by pressing inward on the white connector, pressing in the black release, and finally pulling back on the hose.

WARNING

Since the fuel supply hose may be under pressure, remove it slowly to release the pressure. Place an absorbent towel around the connection to absorb gasoline; then remove the hose slowly to release the pressure. Always wear safety glasses when removing the fuel hoses.

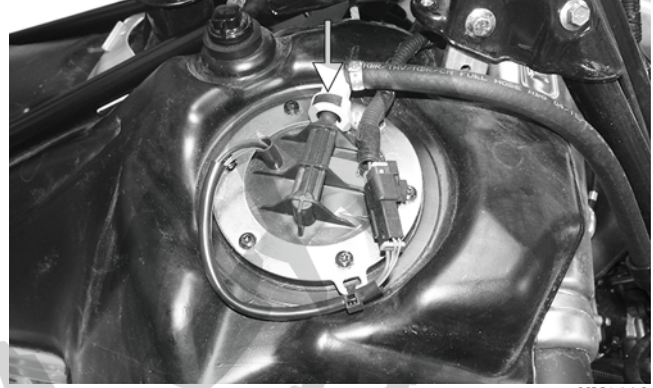

XM211A

- Connect Fuel Pressure Test Kit to the fuel pump and fuel hose.
- Start the engine. Fuel pressure should be as specified.

4000	42.8-47.3 psi
6000	58-62 psi
8000	42.8-47.3 psi

■NOTE: If fuel pressure is not as specified, the pump is defective and must be replaced.

- Disconnect the fuel pump from the main wiring harness.
- Connect the positive lead of a 12-volt power supply to the red wire and the negative lead of the 12-volt power supply to the black wire.
- The pump should operate (it would be heard running).

■NOTE: If the fuel pump fails to operate, reverse the power supply at the fuel pump connector allowing the motor to run in the opposite direction. This will verify that nothing has entered and/or obstructed the pump.

■NOTE: If the fuel pump still fails to operate, the pump is defective and must be replaced.

REMOVING

- Remove both access panels, hood, upper and lower consoles, and seat.
- Disconnect the fuel pump harness connector; then disconnect the gasoline hose from the outlet of the fuel pump by pressing inward on the white connector, pressing in the black release, and finally pulling back on the hose.

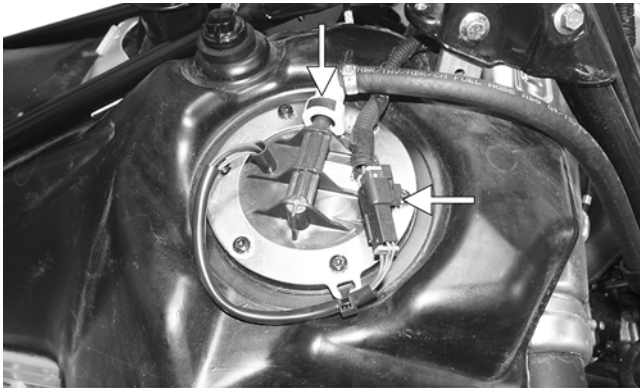

XM211B

WARNING

Since the fuel supply hose may be under pressure, remove it slowly to release the pressure. Place an absorbent towel around the connection to absorb gasoline; then remove the hose slowly to release the pressure. Always wear safety glasses when removing the fuel hoses.

3. Remove and retain the six torx-head screws securing the fuel pump in the fuel tank; then remove the retaining ring.
4. Carefully remove the fuel pump and fuel pickup assembly from the gas tank noting the orientation of the fuel pump outlet for assembling purposes.

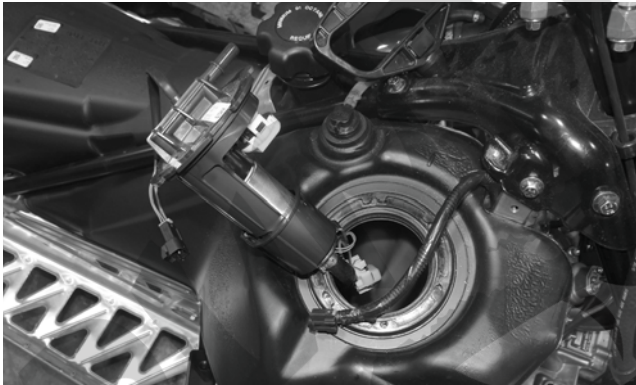

SNO-702

■NOTE: If the fuel pickup assembly is not being replaced, inspect the screens for any tears or obstructions. Also check the hoses and replace if necessary.

INSTALLING

1. Slide Fuel Pump Installation Tool onto the fuel hose near the “Y” fitting until the tool touches the middle pickup. The two rear pickups should be pulled together.

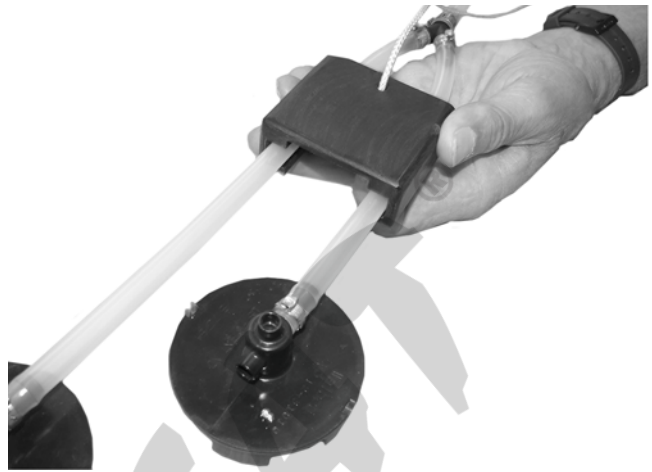

SNO-704

2. Carefully push the fuel pump assembly down and back into the fuel tank until the white fuel sensor (below the fuel pump) is flush with the fuel pump mounting surface.



SNO-705

3. While holding the fuel pump with the white fuel sensor in this position, pull the tool up to the tank opening with the retrieval cord.



SNO-744

■NOTE: Tip the fuel pump assembly to one side enough to allow the tool to be removed.

■NOTE: When the fuel pump hose assembly is installed correctly, the two rear pickups will lie flat in the rear of the fuel tank.

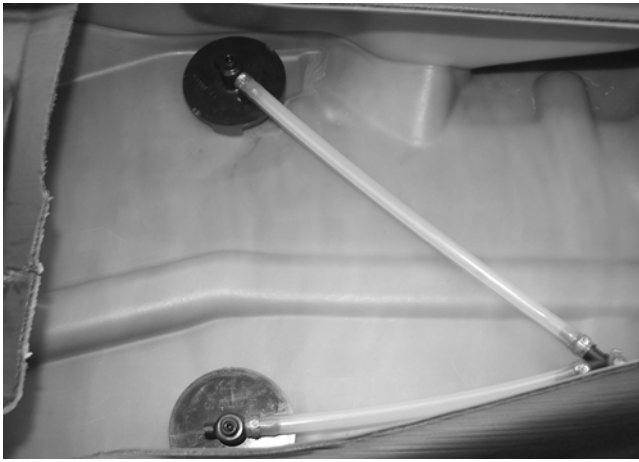

SNO-791

4. Make sure the front pickup will sit flat on the bottom of the tank with no kinks in the fuel hose.



SNO-706

5. Install the retaining ring over the fuel pump and secure the fuel pump to the gas tank assembly using the existing torx-head screws. Tighten to 40 in.-lb.

CAUTION

Use care not to over tighten the retaining plate screws or damage to the gas tank may result.

6. Connect the fuel pump harness connector to the main harness and secure to the retaining ring with a cable tie; then secure the gasoline hose to the fuel pump making sure it locks into place.
7. Install the upper and lower consoles using existing machine screws; then install the seat (see the Steering and Body section), hood, and access panels.

Troubleshooting

Problem: Too Rich

Condition	Remedy
<ol style="list-style-type: none"> 1. Diagnostic trouble code activated 2. Fuel pressure too high 3. Fuel return hose obstructed 4. Injectors leaking 	<ol style="list-style-type: none"> 1. Replace problem sensor 2. Replace regulator 3. Service - replace hose - remove obstruction 4. Replace injectors

Problem: Too Lean

Condition	Remedy
<ol style="list-style-type: none"> 1. Diagnostic trouble code activated 2. Fuel pressure too low 3. Vent hose obstructed 4. Fuel filter(s) obstructed 	<ol style="list-style-type: none"> 1. Replace problem sensor 2. Replace regulator/fuel pump 3. Remove obstruction 4. Replace fuel filter(s)

Oil-Injection Pump (4000/8000)

CAUTION

When servicing the oil-injection system, use a 100:1 gas/oil mixture in the gas tank to ensure adequate engine lubrication. Failure to use the 100:1 mixture to the oil-injection system will result in severe engine damage.

REMOVING

■NOTE: To service the oil-injection pump, the exhaust system and the air silencer must be removed (see the Engine-Related Items section).

1. Remove the throttle bodies and secure them out of the way in an upright position.
2. Disconnect the oil-supply hose from the pump and plug to prevent oil drainage.
3. Remove the oil-delivery hoses from the adapter plates/intake flanges.
4. Disconnect the oil-injection cable/control rod.
5. Remove the two screws securing the oil-injection pump and retainer to the crankcase; then pull the oil-injection pump away from the retainer/crankcase and account for a gasket/O-ring.

■NOTE: Remove the oil-injection pump from the crankcase only if the O-ring or gasket need to be replaced.

6. Turn the pump sideways; then remove the lower union bolt (4). Account for two washer gaskets (1) (3). Remove the pump.

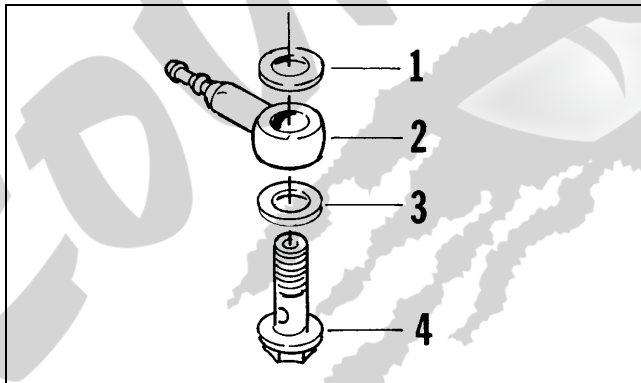

731-551A

7. Remove the remaining union bolts securing the check valves to the pump. Account for the washer gaskets.
8. Remove the check valves. Account for two gaskets.

INSTALLING

1. In turn on each front union bolt, install a washer gasket, check valve, and washer gasket; then install on the oil-injection pump.

2. Place the gasket and oil-injection pump near the engine; then install the lower union bolt through a gasket, check valve, and gasket.
3. Position the oil-injection pump on the engine making sure the oil-injection pump gear is correctly aligned with the oil-injection pump drive gear.
4. Secure the pump with two screws (coated with blue Loctite #243). Tighten screws to 96 in.-lb.
5. Connect the oil-delivery hoses to the adapter plates. Secure with clamps.
6. Connect the oil-injection cable/control rod to the pump and secure.
7. Connect the oil-supply hose to the oil-injection pump inlet fitting. Secure with the clamp.
8. Bleed the oil-injection system.
9. Check the oil-injection system synchronization (see SYNCHRONIZING in this sub-section). Tighten the jam nuts securely.
10. Install the throttle bodies.

■NOTE: Install the exhaust system and the air silencer (see the Engine-Related Items section).

SYNCHRONIZING

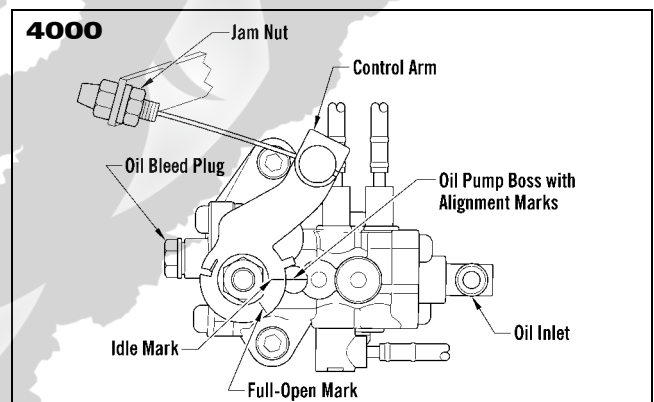

0742-331

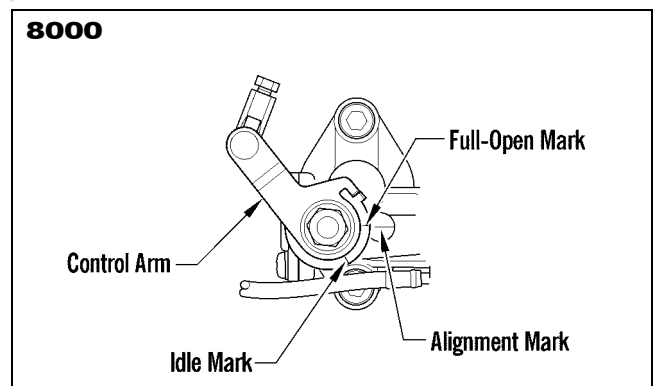

0746-376

1. Rotate the control rod until the setting for oil pump at wide open throttle is 1 to 1.5 lines lean. Return the control rod/throttle cable to the Idle position.

CAUTION

Assure the throttle cable/linkage has returned to the fully closed (idle) position and has not remained partially open and moves freely from the open position to the closed position.

2. Open and close the throttle lever to verify proper operation and that the throttle linkage returns to the fully CLOSED position. **Do not adjust the oil pump at idle, only at WOT.**

TESTING

■NOTE: These tests must be made with the snowmobile and oil at a “room” temperature of 20°-30° C (68°-86° F).

WARNING

Always wear safety glasses when performing this test.

1. Disconnect the oil pump cable/control rod from the control rod on the pump.
2. Clamp off the oil-supply hose between the oil reservoir and oil pump; then remove the supply hose from the pump.
3. Attach a suitable length of clear oil-supply hose to the oil pump; then using Oil Injection Usage Tool, fill the hose with Arctic Cat Synthetic APV 2-Cycle Oil.

■NOTE: Do not fully insert the usage tool into hose. There must be enough room around the tip of the tool and the hose to allow air in the hose to escape.

4. Fill the tool to the 0 line.
5. Wipe the tip of the tool to remove excess oil; then attach the tool to the oil-supply hose and remove the bulb.
6. Secure the tool to the oil reservoir by twisting the rubber strap one half turn and placing the rubber strap around the tool and the oil reservoir filler neck.

■NOTE: To access the oil pump, the air intake boot must be removed.

■NOTE: The control rod must be secured in the Idle position. Secure the rod away from any moving parts to prevent misalignment of the control rod due to engine/chassis movement.

WARNING

Keep hands and clothing away from all moving or rotating parts.

7. With the control rod secured in the Idle position, start the engine and run the engine at recommended RPM for 3 minutes. Compare the amount of oil used against the specifications listed.

Model	RPM	Full-Closed (Idle) 3 Minutes
8000	1833	1.32-3.48 cc
4000	1833	1.0-2.5 cc

■NOTE: Before starting the engine, make sure that no air is present in the testing equipment.

8. With the control rod secured in the Full-Open position (line-to-line), run the engine at recommended RPM for 2 minutes. Compare the amount of oil used against the specifications listed.

Model	RPM	Full-Open 2 Minutes
8000	1833	8.74-10.8 cc
4000	1833	7.4-10.3 cc

9. If the oil-injection pump output does not meet the specifications, see TESTING CHECK VALVES in this sub-section.
10. Disconnect the oil usage tool, remove the plug from the reservoir, and attach the oil-supply hose to the oil reservoir.

■NOTE: After testing the oil pump, the oil pump must be correctly synchronized with the carburetors/throttle bodies (see SYNCHRONIZING in this sub-section).

TESTING CHECK VALVES

If an engine problem occurs due to lack of lubrication, the check valves should be tested using a vacuum pump to make sure they are operating properly.

1. Remove the check valves from the oil-injection pump.
2. Attach the Vacuum Test Pump hose to the check valve.
3. Squeeze the vacuum pump handle and watch the pump gauge. The check valve should release at 4.5-5 lb and again reset itself at 3.5-4 lb. If “release” and “reset” are not within specifications, replace the check valve.
4. Record the “release” and “reset” readings for the valve; then perform the test on the other valve. The “release” and “reset” readings must fall within specifications and must be within 1.5 lb of each other. If either or both are not met, replace the check valves.
5. If the check valves are within specifications but oil-injection usage is not, replace the oil-injection pump.

Electric Oil Pump (6000)

REMOVING

1. Remove the right-side access panel; then remove the torx screw securing the right-side skid plate and secure it out of the way.
2. Using a handlebar stand, carefully tip the snowmobile onto the left side.

■NOTE: When removing the oil pump assembly, make sure the oil level is low enough so when the pump is removed that oil does not leak out of the oil tank.

- Remove all four hoses from the oil pump assembly; then disconnect the oil pump harness and remove the two screws securing the oil pump to the oil tank.



CWI-103

- Carefully remove the oil pump from the oil tank.

■NOTE: Do not disassemble the oil pump as it will only be serviced as a assembly.

INSTALLING

- Install the pump assembly into the oil tank and align with the two mounting holes; then secure the pump to the tank using the two screws (threads coated with blue Loctite #243). Tighten to 60 in.-lb.

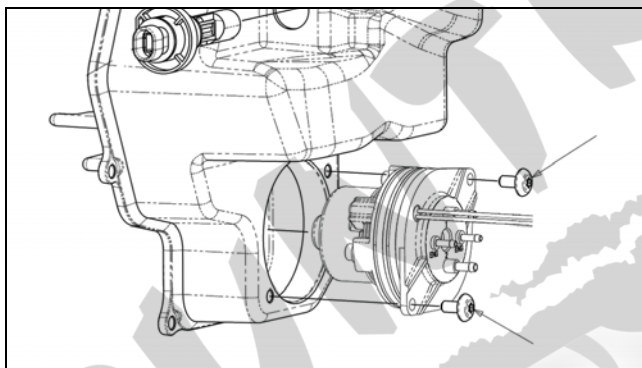

SNO-356

- Install the two clear smaller hoses to the smaller front and rear terminals (A); then install the hose from the center cavity of the crankcase to the top terminal (B). Install the hose from the fuel rail to the lower terminal (C). Secure using the existing clamps.

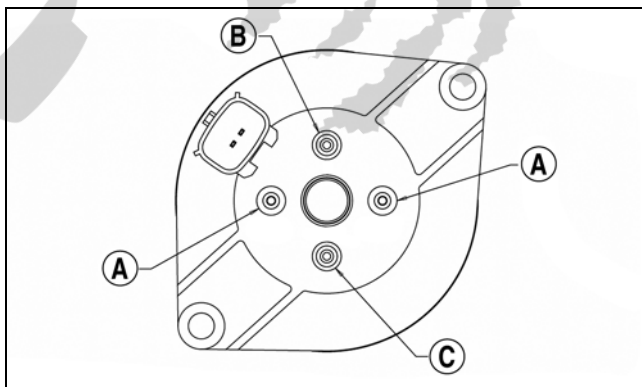

SNO-355A

- Secure the right-side skid plate using the existing screw.

- Bleed the oil-injection system using the CATT II tool. Instructions included with the tool.

■NOTE: If a new oil pump is being installed, be sure to enter the A and B codes using the CATT II Tool.

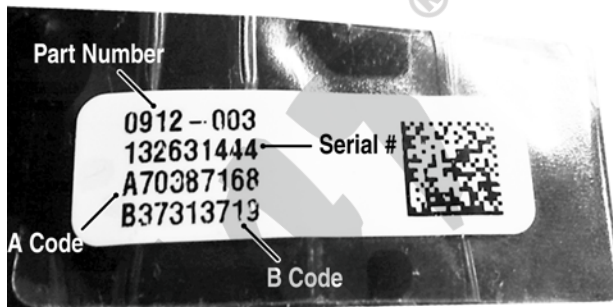

SNO-1236A

Gas Tank

REMOVING

- Remove the hood, access panels, and seat.
- Remove the lower console.
- Disconnect the reverse alarm; then remove the two machine screws securing the upper console. Remove the console.
- Remove and retain all cap screws securing the rear spar tubes to the chassis and steering support. Account for inserts and nuts.



XM210A

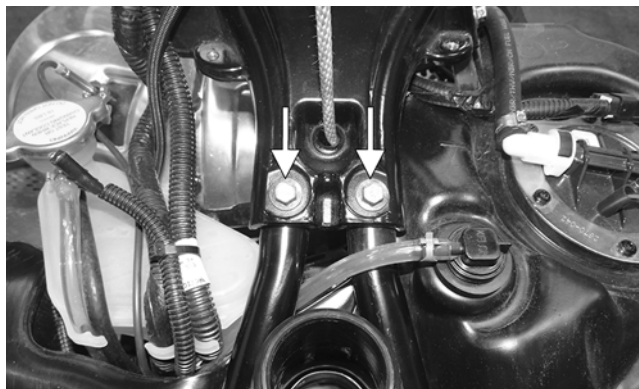

XM212A

5. Disconnect the gasoline hose, vent hose, and fuel pump harness. Remove the gas tank.

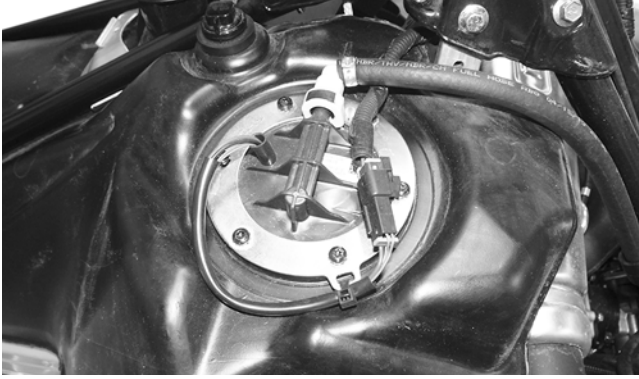

XM211

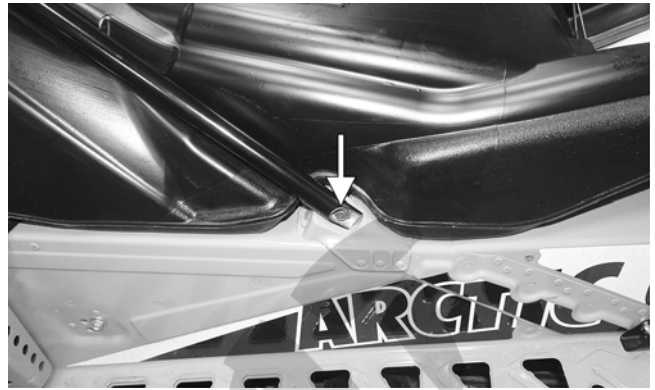

XM210A

INSTALLING

1. Install the gas tank; then connect the gasoline hose, vent hose, and fuel pump harness.
2. Install the rear spar tubes and secure to the chassis and steering support using the four cap screws. Tighten to 23 ft-lb.

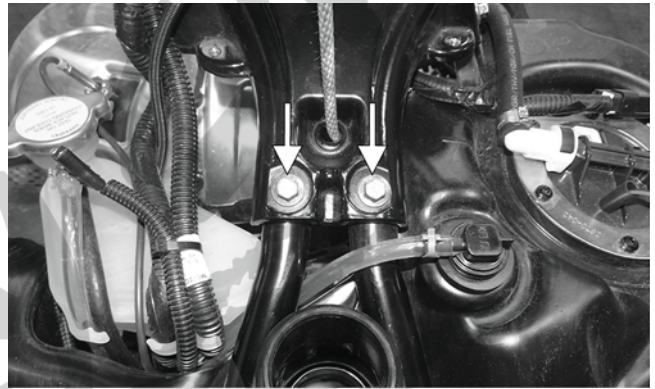

XM212A

3. Connect the reverse alarm; then use the two machine screws to secure the upper console.
4. Install the lower console; then install the seat, hood and both access panels.

COUNTRY

Electrical Systems

All tests of the electrical components should be made using the digital Fluke Model 77 Multimeter. Replace any component that does not have a test value within specifications.

■ **NOTE:** Whenever using a digital-style tester, “open (infinite resistance)” denotes an overload and the meter reading will be OL since the meter is not calibrated to register resistance values of that magnitude.

■ **NOTE:** Always check the appropriate fuse before testing a component for failure.

■ **NOTE:** Whenever a part is worn excessively, cracked, or damaged in any way, replacement is necessary.

SPECIAL TOOLS

A number of special tools must be available to the technician when servicing the electrical systems.

Description	p/n
CATT II	0544-023
Arctic Cat Diagnostic System Manual	2256-974
Laptop Diagnostic Tool	0744-048
Actuator Test Harness	0644-518
Fluke Model 77 Multimeter	0644-559
MaxiClips	0744-041
Throttle Position Sensor (TPS) Adjustment Tool Kit	3639-891

■ **NOTE:** Special tools are available from the Arctic Cat Service Parts Department.

Ignition System

■ **NOTE:** There must be 0.030-0.060 in. free-play between the throttle lever and the control housing.

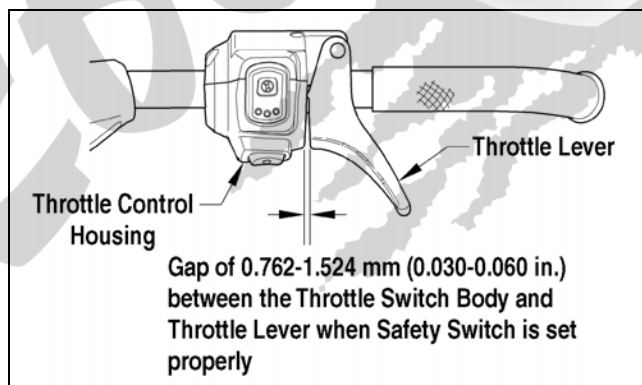

741-518B

TROUBLESHOOTING

1. Remove the spark plugs and visually check their condition. Replace any fouled plug. Attach the spark plugs to the high tension leads and ground them to the engine.

CAUTION

Before checking for spark, place all the engine switches in the deactivated position. In the event the engine could be flooded, engage the starter several times to clear the engine of excess fuel.

CAUTION

Never crank the engine over without grounding the spark plugs. Damage to coils and/or CDI/ECM may result.

■ **NOTE:** Make sure the ignition switch and the emergency stop switch are in the ON position.

2. Crank the engine over and check for spark. If no spark is present, check to make sure the throttle cable is properly tensioned. Compress the throttle control and while holding the throttle control in this position, crank the engine over and check for spark. If spark is now present, adjust the throttle cable tension.

TESTING

Throttle Control Switch

1. Disconnect the handlebar harness connector; then connect the ohmmeter leads as shown below.

Wire	Wire
Black/White	Black/Blue

2. With the throttle lever in the idle position, the meter must read less than 1 ohm. If the meter reads OL (infinite resistance), replace the control assembly.
3. Move the throttle lever to the wide open position. The meter must read OL (infinite resistance). If the meter reads less than 1000 ohms, replace the control assembly.
4. Connect the ohmmeter leads as shown below.

Wire	Wire
Black/Blue	Violet/Red

5. With the emergency stop switch in the off position, the meter must read less than 1 ohm. If the meter reads OL (infinite resistance), replace the control assembly. With the emergency stop switch in the (RUN) position, the meter must read OL (infinite resistance). If the meter reads less than 1000 ohms, replace the control assembly.

Throttle Position Sensor

■ **NOTE:** Two-stroke engines equipped with a throttle position sensor have a protective feature called “fail-safe” ignition timing preventing engine damage should the TPS fail. If the TPS does fail, the engine may run normally at low RPM but will run poorly at high RPM allowing the operator to get the snowmobile to safety with no engine damage. The engine will continue to operate this way until the TPS is adjusted or replaced.

CHECKING TPS

■NOTE: If the snowmobile is in warranty, breaking the seal on the idle screw jam nut or the Phillips-head screws on the TPS will void warranty. If the TPS is tested out of specification, the throttle body must be replaced. If the snowmobile is out of warranty, proceed to Adjusting TPS.

6000

■NOTE: On the 6000, the TPS should only be checked using the CATT II Tool. Instructions will be included with the tool.

4000/8000

On the 4000/8000 before using the TPS adjustment tool, verify its battery condition. The battery used in the tool is a 9-volt battery. To check battery condition, use a digital volt/ohmmeter set on DC volt scale. Test between the adjustment tool black and red jacks. Insert the red lead of the digital voltmeter into the red jack of the adjustment tool and the black lead of the digital voltmeter into the black jack of the adjustment tool. The green power light of the analyzer should now be illuminated. If voltage is found below 4.9 volts, replace the battery.

■NOTE: The Test Harness must be plugged into the analyzer for testing voltage. Always verify battery voltage is at least 4.9 DC volts before testing TPS.

1. Using Throttle Position Sensor (TPS) Adjustment Tool Kit, connect its wiring harness to the TPS.
2. Connect the red and black digital voltmeter leads to the white and black jacks of the TPS adjustment tool.
3. Ensure that the throttle cable/control rod has the proper amount of free-play.
4. With the throttle in the idle position, compare the reading on the voltmeter to the chart. If the reading is within prescribed specification, proceed to step 6.

Model	Idle	Full-Open
8000	0.710-0.818	3.472-4.048
4000	0.646-0.754	3.472-4.485

5. Compress the throttle lever slowly to the full-open position. The meter reading should show a smooth rise in voltage all the way to the full-open position. If the voltage seems to be erratic or doesn't meet the prescribed specification, repeat this procedure several times to confirm results.

■NOTE: If at any point throughout the throttle range the meter reads no voltage (open), hold the throttle lever in that position. If the voltage does not return, the throttle body must be replaced.

6. If the full-open throttle voltage remains erratic or out of specification, proceed to the appropriate Adjusting TPS.
7. If the TPS is within the prescribed specification, disconnect the adjustment tool harness from the TPS. Connect the snowmobile TPS harness to the TPS.

■NOTE: Before installing the TPS harness connector, apply dielectric grease to the connector pins.

ADJUSTING TPS

■NOTE: Adjusting the TPS is for out of warranty snowmobiles only.

6000

■NOTE: On the 6000, the TPS should only be adjusted using the CATT II Tool. Instructions are included with the tool.

Idle	Full-Open
1.12v ± 0.075v	4.416v ± 0.15v

4000/8000

■NOTE: It is important that the throttle shaft is in the completely closed position for this procedure.

1. Disconnect the throttle cable/control arm from the throttle shaft.
2. Rotate the idle screw counterclockwise until it no longer contacts the throttle shaft stop. The throttle shaft should now be completely closed. Open the throttle shaft by hand and release it, allowing the shaft to gently snap closed several times.
3. Disconnect the TPS wiring harness from the TPS; then using Throttle Position Sensor (TPS) Adjustment Tool, connect the appropriate wiring harness to the TPS. Connect the red and black digital voltmeter leads to the white and black jacks of the TPS adjustment tool.
4. While observing the digital voltmeter, slowly rotate the sensor until the Full-Closed specification is observed on the LCD of the multimeter. While holding the sensor in this position, tighten the two screws which secure the sensor to the throttle body securely.
5. Gently snap the throttle open and closed several times to check the TPS voltage. If it has changed from the Full-Closed specification, loosen the two screws which secure the sensor and make necessary adjustments.
6. With the full-closed position set to specification, rotate the idle screw clockwise until it contacts the throttle shaft stop. Using the digital multimeter and test harness, rotate the idle screw inward until the Idle specification is observed.

■NOTE: Rotate the idle screw past the recommended voltage specification by two or three volts; then rotate the idle screw counterclockwise to the correct idle position voltage.

7. With the idle position set to specification, slowly compress the throttle lever to the full-open position. The full-open specification should be observed. Gently snap the throttle lever open and closed several times and note if the reading remains within the specification.

■NOTE: If, after adjusting the Throttle Position Sensor to the IDLE specification, the FULL-OPEN is less than the specified voltage, recheck the FULL-CLOSED setting. If the FULL-CLOSED setting is correct, replace the sensor.

Engine	TPS TOOL (DC VOLTS)		ANALYZER TOOL (DC VOLTS)
	4000	Full-Closed	0.412-0.414
Idle		0.710-0.818	0.710-0.818
Full-Open		3.472-4.048	3.470-4.046
			DIAGNOSTIC TOOL
8000	Full-Closed	0.412-0.414	
	Idle	0.646-0.754	3.99° -6.66°
	Full-Open	3.472-4.485	74.97°-89.37°

REPLACING TPS (4000/8000)

■NOTE: Replacing the TPS is for out of warranty snowmobiles only.

Removing

1. Remove the expansion chamber and resonator.
2. Rotate the idle screw counterclockwise until it no longer contacts the throttle shaft stop. The throttle shaft should now be completely closed.
3. Disconnect TPS wiring harness from the TPS; then noting the position of the TPS, remove the two screws securing the TPS to the throttle body and remove the sensor.

Installing

1. Apply a light film of silicone grease to the O-ring. Install the O-ring into the groove.
2. Install the new TPS onto the throttle shaft by aligning the “flats” on the throttle shaft cam with the “flats” on the sensor; then rotate the sensor until properly positioned on the throttle body.
3. Install the sensor to the throttle body. Do not tighten at this time.
4. Adjust the TPS (see appropriate Adjusting TPS in this sub-section).

■NOTE: Before installing the TPS harness connector, apply dielectric grease to the connector pins.

5. Disconnect the adjustment tool harness from the TPS. Connect the snowmobile TPS harness to the newly installed or adjusted TPS.
6. Install the resonator and expansion chamber.

REPLACING TPS (6000)

■NOTE: Replacing the TPS is for out of warranty snowmobiles only.

Removing

1. Rotate the idle screw counterclockwise until it no longer contacts the throttle shaft stop. The throttle shaft should now be completely closed.

2. Disconnect TPS wiring harness from the TPS; then noting the position of the TPS, remove the two screws securing the TPS to the throttle body and remove the sensor.

Installing

1. Install the new TPS onto the throttle shaft by aligning the “flats” on the throttle shaft cam with the “flats” on the sensor; then rotate the sensor until properly positioned on the throttle body.

■NOTE: Before installing the TPS harness connector, apply dielectric grease to the connector pins.

2. Install the sensor to the throttle body. Do not tighten at this time.
3. Adjust the TPS using the CATT II Tool.

Electrical Resistance Tests

■NOTE: Replace any component that does not have a test value within specifications. If the component tests satisfactorily but is suspected to be faulty, connect the red meter lead to a component lead and the black meter lead to ground. Check for continuity between the component and ground. If continuity is observed, replace the component.

■NOTE: The following test should be made using MaxiClips and the Fluke Model 77 Multimeter set to OHMS scale.

CAUTION

Always disconnect the battery when performing resistance tests to avoid damaging the multimeter.

Charge Coil (1)

1. Disconnect the triple-wire plug from the main harness to the magneto.
2. Connect the red meter lead to the black/red wire in the plug; then connect the black meter lead to the green/red wire in the plug.
3. Resistance must be 8.8-13.2 ohms.

Charge Coil (2)

1. Disconnect the triple-wire plug from the main harness to the magneto.
2. Connect the red meter lead to the brown/white wire in the plug; then connect the black meter lead to the green/red wire in the plug.
3. Resistance must be 8.8-13.2 ohms.

Fuel Pump Coil

■NOTE: With the engine running, there should 14.5-17.5 DC volts supplied to the fuel pump for operation.

1. Test between the two orange wires in the four-prong connector from the magneto.

- Resistance must be 1.52-2.28 ohms.

Injection Coil

- Test between the two blue/white leads in the four-prong connector harness from the magneto.
- Resistance must be 15.2-22.8 ohms.

Lighting Coil

- Disconnect the main harness from the magneto.
- Connect the two meter leads to each of the yellow leads in the connector from the engine.
- Resistance must be 0.08-0.12 ohm.

Ignition Timing Sensor (4000)

- Disconnect timing sensors 1 and 2 (green/white and brown/green) from the main harness.
- Connect the meter leads to the sensor leads.
- Resistance must be 80.8-121 ohms.

Ignition Timing Sensor (6000/8000)

- Disconnect timing sensors 1 and 2 (green/white and brown/green) from the main harness.
- Connect the meter leads to the sensor leads.
- Resistance must be 148-222 ohms.

Ignition Coil (Primary)

- Disconnect the double wire plug from the main harness to the ignition coil.
- Connect the red meter lead to the orange/black (4000) or black/white (6000/8000) lead; then connect the black meter lead to the orange/red (4000) or white/blue (6000/8000) lead.
- Ignition coil primary resistance must be between 0.24-0.36 ohm.

Ignition Coil (Secondary) (4000)

- Remove the spark-plug caps from the high tension wires.
- Connect the red meter lead to one high tension wire; then connect the black meter lead to ground.
- Resistance must be 6800-10,200 ohms.

Ignition Coil (Secondary) (6000/8000)

- Remove the spark-plug caps from the high tension wires.
- Connect the red meter lead to one high tension wire; then connect the black meter lead to ground.
- Resistance must be 5040-7560 ohms.

Spark-Plug Cap

- Remove the spark-plug caps from the high tension wires.
- In turn on each cap, touch a tester lead to each end of the spark-plug cap.

- Resistance must be 4000-6000 ohms.

Ignition Switch

■NOTE: The console must be removed to access the ignition switch.

- Remove the main wiring harness connectors from the ignition switch.
- Rotate the key to the OFF position.
- Resistance must read less than 1 ohm between the ignition switch terminals.
- Rotate the key to the RUN position. The meter must read OL (infinite resistance).

Fuel Injector

- Disconnect the fuel injector wiring harness; then set the meter to the OHMS position.
- Test between the two injector terminals. Resistance must be 10-14 ohms (4000/8000) or 11.4-12.6 ohms (6000).
- If not within specifications, replace the injector.

■NOTE: When replacing the injector on the 6000, the A and B codes must be entered using the CATT II Tool.

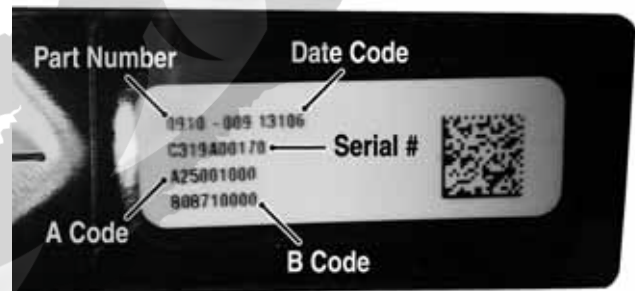

SNO-1235A

Exhaust Temperature Sensor

- Disconnect the sensor harness; then remove the sensor from the exhaust pipe.
- Suspend the sensor (only up to the threads) in a container filled with automatic transmission oil; then slowly heat the oil on a hot plate.
- Using a fluid thermometer, closely monitor the oil temperature, and using a digital multimeter with the leads connected to the sensor leads, observe the resistance reading.
- The sensor must read as shown (see chart).

° F	° C	ohms
77	25	219.6
122	50	238.5
212	100	275.9
302	150	312.7

Coolant Temperature Sensor

1. Disconnect the coolant temperature sensor wiring harness from the main harness.
2. Test the resistance between the two leads from the sensor.
3. Compare the resistance reading to the Voltage/Resistance Chart - Coolant Temperature in this section.

Air Temperature Sensor

■NOTE: The component temperature must be known before conducting this test. Allow the engine to reach room temperature.

1. Disconnect the wiring harness from the air temperature sensor.
2. Test the sensor connector. Compare with the Voltage/Resistance Chart - Air Temperature in this section.

■NOTE: The air temperature sensor utilizes a thermistor. Resistance will change as temperature varies.

Testing Electric Oil Pump (6000)

1. Remove the right-side access panel; then remove the lower console from the skid plate. Disconnect the oil pump connector.

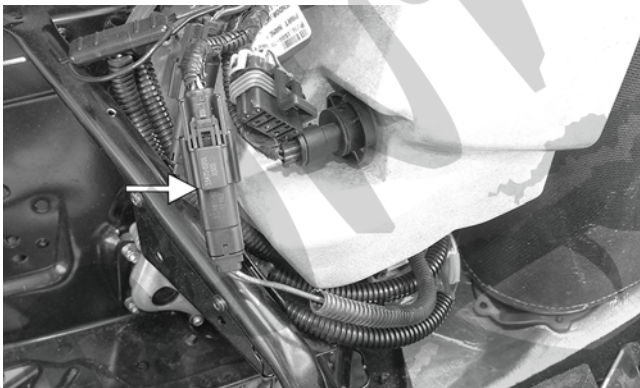

2. Set the selector to the OHMS position.
3. Test between the two terminals. Resistance must be 1.75-1.95 ohms.

■NOTE: If replacing the oil pump, the A and B codes must be entered using the CATT II Tool. The pump must also be primed using the CATT II Tool.

Testing Voltage Regulator

■NOTE: The following test should be made using MaxiClips and the Fluke Model 77 Multimeter set to DC Volt scale.

⚠ WARNING

Most voltages generated by the ignition system are sufficient to interrupt pacemakers! All technicians, especially those using pacemakers, must avoid contact with all electrical connections after the engine has been started.

6000

1. For the DC voltage test, connect the red meter lead to the red/blue wire in the accessory connector (near the oil pump); then connect the black meter lead to the black wire in the connector.
2. Start the engine and allow it to idle. Meter reading must be within 9-14.5 DC volts.

8000

1. For the DC voltage test, connect the red maxiclip and meter lead to the red/blue wire in the three-wire connector; then connect the black maxiclip and meter lead to the brown wire in the connector.
2. Start the engine and allow it to idle. Meter reading must be within 12-15 DC volts.
3. For the AC voltage test, connect the red maxiclip and meter lead to the yellow wire in the connector; then connect the black maxiclip and meter lead to the brown wire in the connector.
4. Start the engine and allow it to idle. Meter reading must be within 11-14 AC.

4000

This test should be made at the three-pin connector of the regulator/rectifier.

1. Connect the red maxiclip and meter lead to the red/blue lead of the connector; then connect the black maxiclip and meter lead to the black lead of the connector.
2. Start the engine and allow it to idle. Meter reading must be within 10-15 DC volts.
3. Connect the red maxiclip and meter lead to the red/black lead; then connect the black maxiclip and meter lead to the black lead.
4. Start the engine and allow it to idle. Meter reading must be within 10-15 DC volts.

■NOTE: If tests failed, check all connections, etc., and test again. If no voltage is present, replace the stator assembly.

Chassis Control Unit (CCU)/Codes (4000)

The CCU distributes regulated DC power to the chassis electrical systems and controls the forward/reverse shifting of the ACT drive to ensure safe operation.

The CCU has two DC outputs used for lighting circuits. Both outputs have a circuit breaker (self resetting devices) protecting components from over-current and short circuit situations. If a system stops working, a short has likely occurred and the system has shut itself off much like a fuse will blow if a circuit is shorted to ground. However, unlike a fuse if the short is resolved, the CCU will reset the output and the system will return to normal operation.

The first output, labeled the High Power DC Output, supplies power for the headlights and handwarmers and is on only while the engine is running. This output is turned off during shifting to allow maximum power transfer to the ACT drive.

The second output, labeled the Low Power DC Output, supplies power to the gauge, speed sensor, taillight, accessory plugs, and APV servomotor via the Engine Control Unit. This output is on only while the engine is running. It is not turned off during shifting.

■**NOTE:** If the engine will not run, the problem is not related to the CCU.

SERVICE ICON

The Service Icon is controlled by the CCU/ECM and may illuminate for a number of reasons. The icon should illuminate or illuminates each time the engine is started, and it should go out after a few seconds. If the icon stays illuminated while the engine is running, the CCU/ECM is receiving input that is outside of its established parameters.

Accessing CCU Codes

1. Connect the appropriate harness from CCU Diagnostic Test Kit to the diagnostic port.
2. Start the engine. After approximately 5 seconds, the service icon on the gauge will begin flashing.
3. The readout screen will display an error code as CCU followed by a number (refer to the CCU Diagnostic Codes chart for descriptions). When all error codes have been output, the service icon flashes twice quickly.

CCU Diagnostic Codes		
Code	Trouble	Cause
CCU 32	High power DC output over current.	Headlight and Hand Warmer (Red/Black) circuit current greater than 20 Amps.
CCU 33	High power DC output shorted.	Headlight and Hand Warmer (Red/Black) circuit shorted to ground.
CCU 34	Low power DC output over current.	Gauge, Taillight, and APV Servo Power (Red/Blue) circuit current greater than 20 Amps.
CCU 35	Low power DC output shorted.	Gauge, Taillight, and APV Servo Power (Red/Blue) circuit shorted to ground.
CCU 37	System over voltage.	Spike in battery voltage - excessive gear case shifting.
CCU 38	Gear shift actuator failure.	Wires to reverse actuator damaged or shorted to ground.
CCU 42	Tachometer input failure (engine running - no tachometer signal present).	Tachometer signal wire shorted to ground.
CCU 43	Gear position switch failure.	Gear position switch damaged or unplugged - reverse actuator not working correctly.
CCU 44	CCU over temperature.	Internal CCU temperature over 105° C (221° F).

Clearing Fault Codes

1. Connect the appropriate harness from CCU Diagnostic Test Kit to the diagnostic port.
2. Start the engine; then press and hold the shift button for 5 seconds.

■**NOTE:** Two quick flashes of the service icon indicate the codes have been cleared.

Testing Oil Level Sensor

The oil level sensor is a magnetic switch. Its operation is based on a magnet located in the float. The switch located in the stem of the sending unit is positioned through the hole in the float. When the float drops to the lower part of the stem, the magnet closes the electrical contacts (located in the stem) allowing the current to pass on to the warning light.



PC256

1. Verify the oil level is below the float; then remove the sensor from the oil reservoir by twisting and pulling out. Wipe excess oil from the sensor.
2. Unplug the sensor from the wiring harness.

3. Set the meter selector to the OHMS position.
4. Touch each of the meter leads to one of the terminals on the sensor. With the sensor in its normal position (float end down), the meter should read less than 1 ohm.
5. If the meter reads greater than 1 ohm, check to make sure good contact has been made with each of the terminals on the sensor. If the meter still reads greater than 1 ohm, replace the sensor.
6. While maintaining contact between the meter leads and the sensor, raise the float. The meter must read OL (infinite resistance). If the meter reads less than 1 ohm, replace the sensor.
7. If the sensor tests satisfactory but the icon doesn't illuminate with only a small amount of oil in the reservoir, verify the icon illuminates on start-up.

Testing Fuel Gauge Sender

■NOTE: Before testing the sender, verify the harness from the sender to the gauge is satisfactory.

1. Remove the hood.
2. Disconnect the fuel gauge sender unit from the main wiring harness; then connect the ohmmeter leads to the two blue sender wires.
3. Compare the reading to the chart following.

Full	<20 ohms
1/2	40-56 ohms
Empty	76-105 ohms

Emergency Stop Switch

RESISTANCE

1. Remove the four torx-head cap screws securing the front/rear throttle control housing assembly to the handlebar.
2. Set the selector to the OHMS position.
3. Connect one tester lead to one pin; then connect the other tester lead to the other pin.

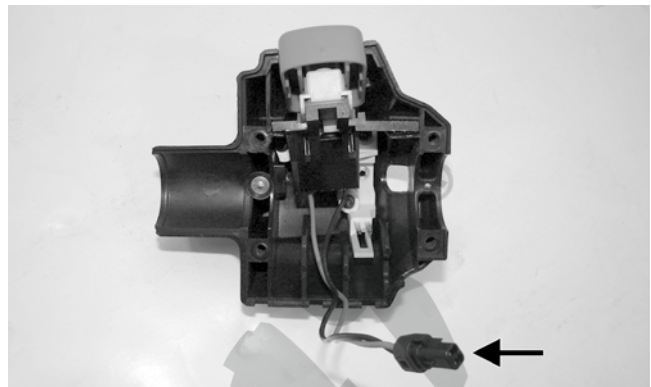

PC253A

4. With the switch in the OFF position, the meter must read less than 1 ohm resistance.
5. With the switch in the RUN position, the meter must read OL (infinite resistance).

■NOTE: If the meter does not show as specified, troubleshoot or replace the switch/component, the connector, or the switch wiring harness.

Starter Relay Solenoid

TESTING

■NOTE: The electric start solenoid may be tested using either one of the following methods.

Method #1

1. Disconnect the solenoid connector from the main wiring harness.
2. Place the ohmmeter leads across the solenoid coil terminals. The ohmmeter must read 3-5 ohms.

■NOTE: An in-line ammeter would measure between 2 and 4 amps of solenoid coil current flow with the battery connected.

CAUTION
NEVER connect an in-line ammeter with the large starter cables because the 200 amps of current flow will instantly damage most ammeters.

Method #2

1. Using the multimeter set to the DC Voltage position, check the relay as follows.
2. Connect the red tester lead to the positive battery terminal; then connect the black tester lead to the starter cable connection on the starter relay. The meter must show battery voltage.

■NOTE: Engage the brake lever lock and place the emergency stop switch in the RUN position.

3. Engage the starter while observing the multimeter. The multimeter should drop to 0 volts and a "click" should be heard from the relay.

■NOTE: If a “click” is heard and more than 1 volt is indicated by the multimeter, replace the starter relay. If no “click” is heard and the multimeter continues to indicate battery voltage, proceed to step 4.

4. Disconnect the two-wire plug from the starter relay; then connect the red tester lead to the green wire and the black tester lead to the black wire.
5. Depress the starter button and observe the multimeter.

■NOTE: If battery voltage is indicated, replace the starter relay. If no voltage is indicated, check fuse or relay.

Fuse

TESTING

1. Remove the fuse from the fuse holder.
2. Connect the ohmmeter across the fuse end-caps.
3. The ohmmeter must read less than 1 ohm of resistance.

Ignition Switch

TESTING

CAUTION

To prevent ohmmeter damage when testing circuits on snowmobiles equipped with an electric start, be sure to disconnect the battery before testing.

1. Disconnect the wiring harness from the ignition switch; then remove the switch from the console.
2. Using the ohmmeter, test the connections indicated in the following chart. If the meter reads more than one ohm of resistance between connected terminals or less than 1 ohm of resistance on non-connected terminals, the switch must be replaced.

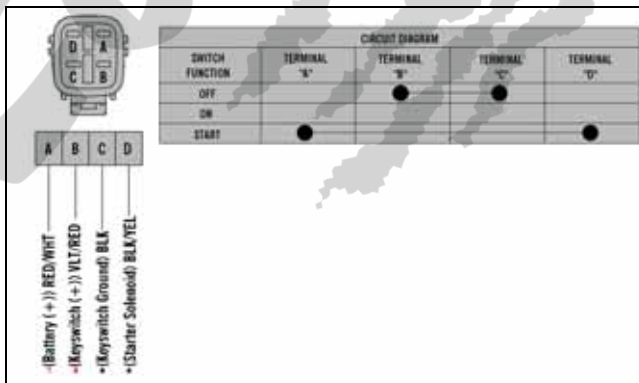

746-238A

■NOTE: If the ignition switch tests good, verify battery voltage to the harness side of the switch plug-in. If there is no voltage, troubleshoot the battery, switch fuse, or starter relay solenoid.

If battery voltage is present at the plug-in and the starter fails to activate, use the following procedure:

1. With the ignition switch plugged in, place the emergency stop switch to the OFF position.
2. Connect the red tester lead to the black/yellow wire; then connect the black tester lead to a suitable ground.
3. Rotate the key to the START position and verify battery voltage.

■NOTE: If no battery voltage is present, troubleshoot the harness and/or the starter relay solenoid.

Starter Motor

REMOVING (8000)

1. Remove the seat and disconnect the battery; then remove the hood and both access panels.
2. Remove all springs securing the expansion chamber and resonator; then remove the expansion chamber and resonator.
3. Remove both torx-head screws securing the front facia pieces; then disconnect the ECM and remove the facia and ECM as an assembly.
4. Remove the two cap screws and nuts securing the shock mount support bracket to the chassis; then remove the mount and servomotor up and out of the way.

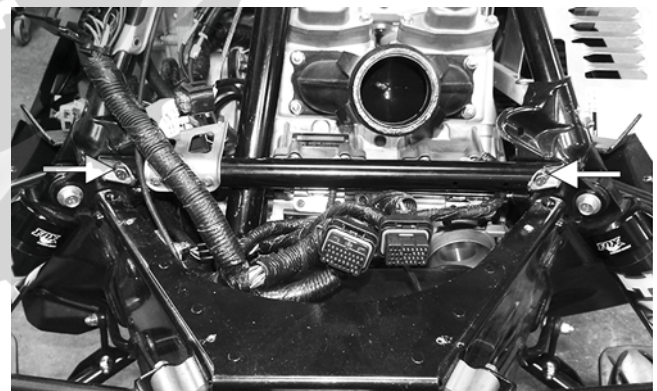

XM039A

5. Disconnect both injector wires from the injectors; then remove the four clamps securing the throttle bodies.
6. Disconnect the oil pump rod from the throttle bodies; then remove and plug the PTO-side coolant hose from the throttle bodies. Lift up the throttle bodies and set out of the way.
7. Remove the throttle body boot from the chassis.
8. Remove the positive battery cable from the starter motor.

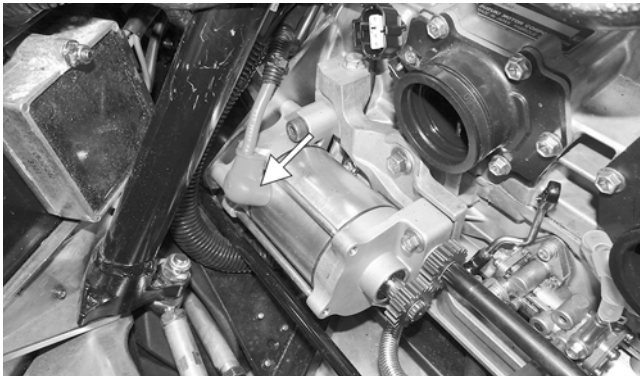

XM040A

- Remove the eight cap screws securing the MAG side of the starter motor to the starter motor retaining plate. Account for the negative battery cable and external tooth washer.

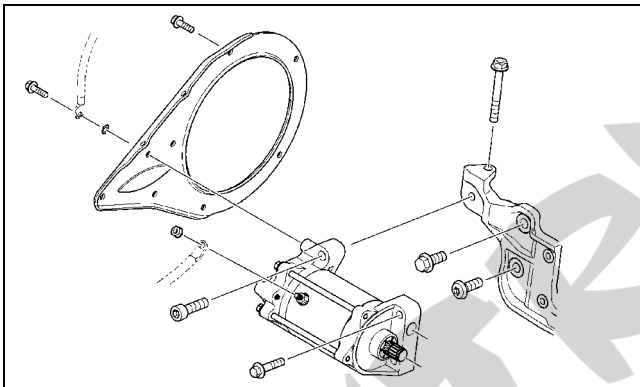

SNO-352

- Remove the two cap screws (A) and one Allen-head screw (B) securing the starter motor to the starter motor mounting bracket. Remove the starter.

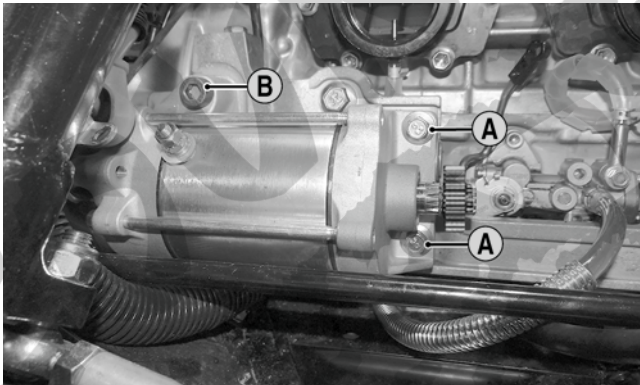

XM044A

- If the starter motor is being replaced, remove the snap ring securing the starter motor gear to the starter motor shaft. Remove the gear.

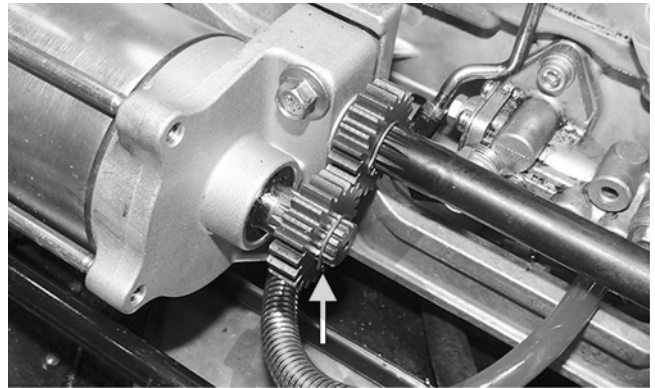

XM041A

REMOVING (6000)

- Remove the seat and disconnect the battery; then remove the hood and both access panels.
- Remove all springs securing the expansion chamber and resonator; then remove the expansion chamber and resonator.
- Remove the two screws (A) securing the heat shield to the chassis; then remove the heat shield from the two front locating pins (B) and remove the heat shield.

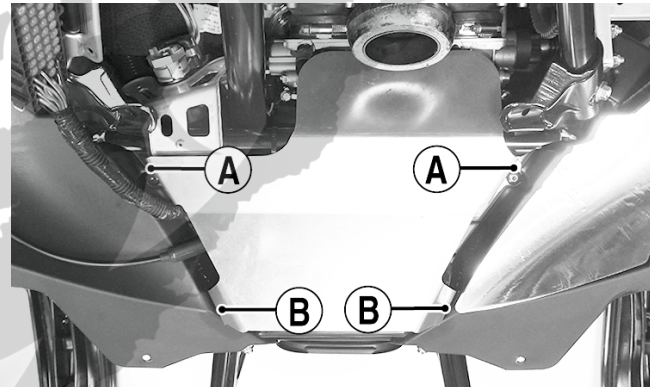

EL-001A

- Disconnect the ECM; then remove the screws securing the right and left-side fascia panels to the chassis. Remove the panels and ECM as an assembly.

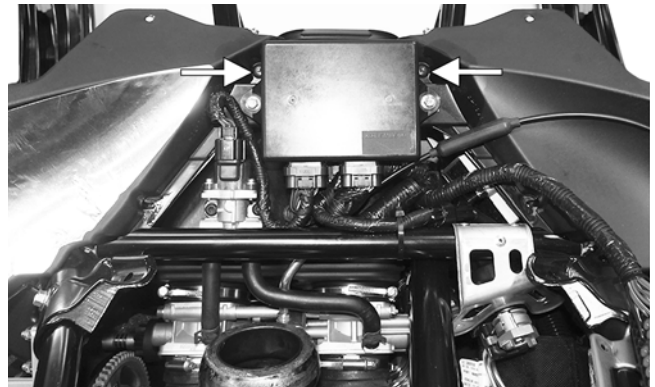

EL-002A

- Remove the cap screws and lock nuts securing the shock mount bracket support to the shock mount brackets; then remove the shock mount bracket support.

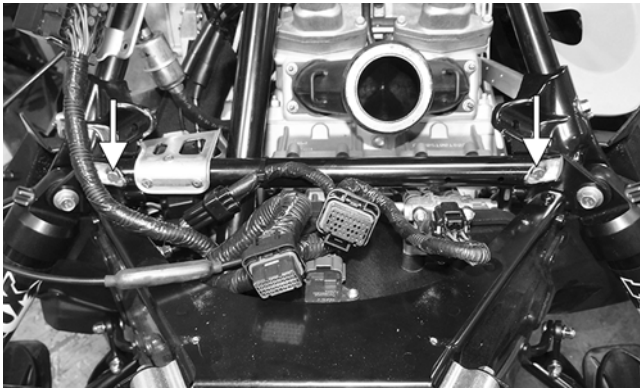

EL-003A

- Remove idle speed control (ISC) hoses (A) from the top of the throttle bodies; then disconnect the ISC from the main harness (B). Remove the screws (C) securing the ISC; then remove the ISC.

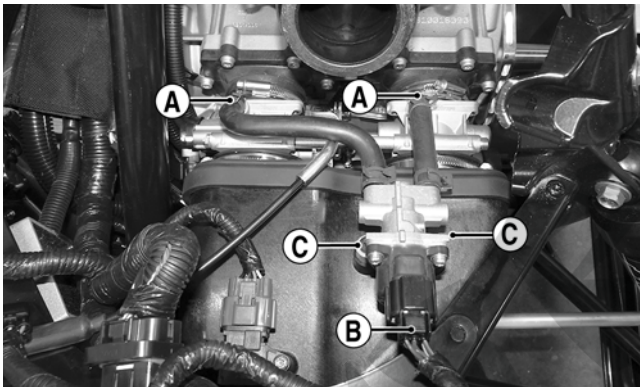

EL-006A

- Loosen the four clamps securing the throttle body; then lift up the throttle body and disconnect the coolant lines. Set the throttle body up and out of the way.
- Remove the intake boot from the chassis.
- Remove the cable ties (A) securing the positive cable to the starter motor; then remove the nut securing the positive cable.
- Remove the four cap screws (B) securing the starter motor to the engine.

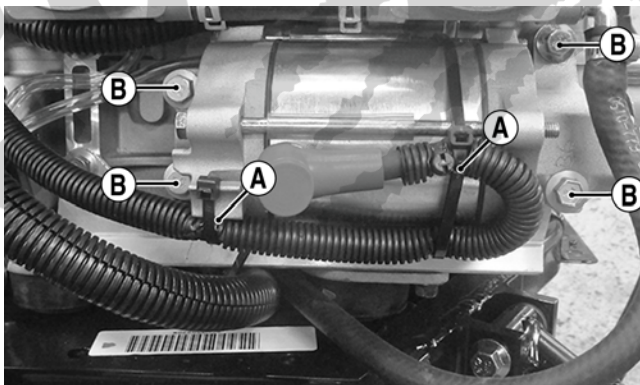

CWI-108A

DISASSEMBLING PINION

- Place a 12 mm socket over the end of the pinion shaft and tap the socket gently with a hammer.

■ **NOTE:** This procedure will dislodge the snap-ring retainer and expose the snap ring.

- Using a suitable pliers and flat-head screw driver, remove and discard the snap ring.
- Remove the snap-ring retainer (note end-for-end orientation), pinion spring, spring retainer, and pinion gear. Retain all components.

CLEANING AND INSPECTING PINION

- Using parts-cleaning solvent, wash grease from the pinion gear. Dry with compressed air.

⚠ WARNING

When using compressed air to dry components, always wear safety glasses.

- Inspect the pinion gear for wear. If the gear is worn or chipped, replace the pinion assembly.
- Inspect the inner gear and housing. If the gear shows any signs of wear, replace the pinion assembly.
- Inspect the inner housing for tightness and cracks. If the housing shows any signs of being loose or cracked, replace the pinion assembly.
- Inspect the pinion return spring for wear. If the spring shows any worn areas, replace the spring.

ASSEMBLING PINION

- With low-temperature grease applied to the threads of the pinion shaft, slide the pinion gear, spring retainer, pinion spring, and snap-ring retainer (note end-for-end orientation) onto the shaft in their original positions.
- Place new snap ring over the end of the pinion shaft; then slide the snap ring over the shaft. Using a 12 mm socket and a hammer, gently tap the snap ring into the groove on the shaft.
- Pull the end cap over the snap ring to lock it in place.

TESTING STARTER MOTOR

■ **NOTE:** Before installing the starter motor, perform test to ensure proper operation using the following procedure.

- Attach a black jumper cable to a good ground on the starter.
- Attach the opposite end of the black jumper cable to the negative post of a good 12V battery.
- Attach the red jumper cable to the positive post of the battery.
- Holding the starter firmly down on a work bench, touch the red jumper cable to the positive cable stud of the starter.

⚠ WARNING

Be sure to keep clear of the pinion gear area as it will spin at a high RPM when the red cable is touched to the positive stud. Personal injury may result if contact is made with a spinning pinion.

■NOTE: The starter motor must instantly spin at a high RPM. On the 6000 the pinion must snap out against the stopper. If the motor does not spin, remove the red cable immediately. Check the battery condition and all connections.

INSTALLING (8000)

1. Secure the starter motor to the starter motor mounting bracket using two cap screws (A) (threads coated with blue Loctite #243) and one Allen-head screw (B) (threads coated with blue Loctite #243). Tighten the Allen-head screw (B) to 25 ft-lb. Tighten the cap screws (A) to 25 ft-lb.

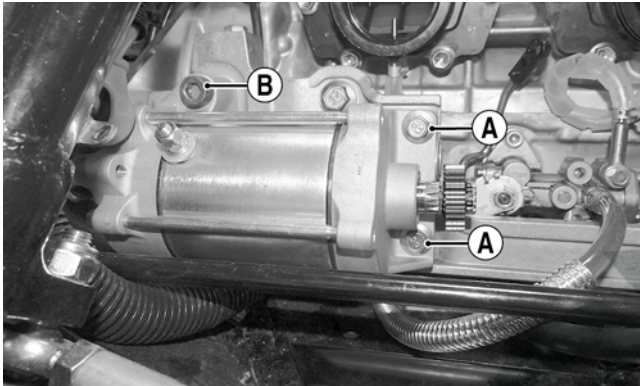

XM044A

2. Secure the MAG-side of the starter motor to the retaining plate using the eight cap screws (threads coated with blue Loctite #243). The washer and negative battery cable must be installed in the upper location. Tighten to 96 in.-lb.

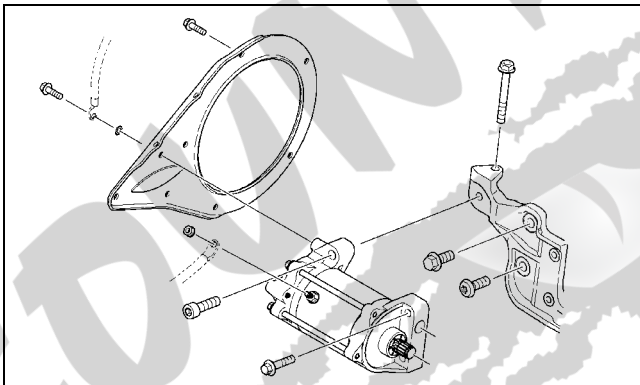

SNO-352

3. Install inner snap ring onto the starter motor (if removed during removing); then install the gear and secure using outer snap ring making sure both snap rings are fully seated.

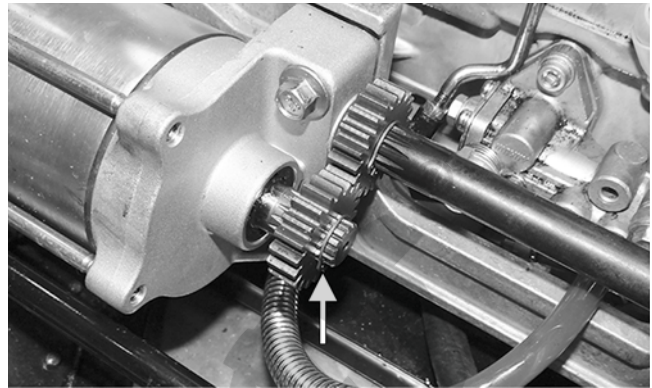

XM041A

4. Secure the positive battery cable to the starter motor and tighten to 72 in.-lb; then install the red cap over the terminal.

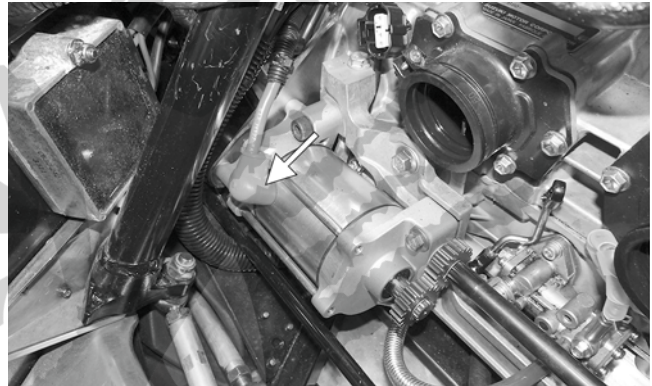

XM040A

5. Install the drive clutch and tighten to 51 ft-lb; then install the belt and driven clutch.
6. Install the throttle body boot; then install the throttle bodies making sure to connect the PTO-side coolant hose, oil pump rod, and injection connections.
7. Secure the throttle bodies using four existing clamps.
8. Install the shock mount support bracket to the chassis using existing cap screws. Tighten to 20 ft-lb.

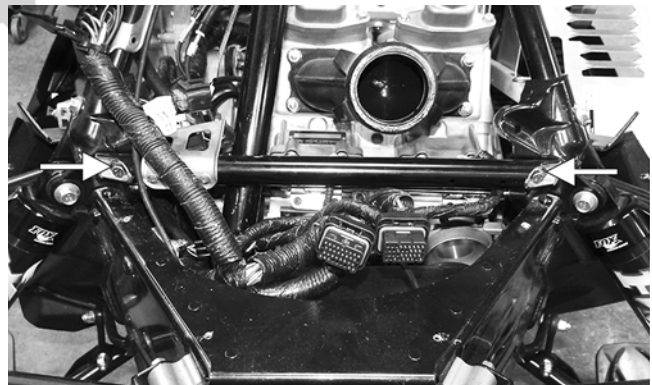

XM038A

9. Secure the ECM and front facia assembly to the chassis using the existing self-tapping screws. Tighten securely.
10. Install the resonator and expansion chamber and secure using existing springs.
11. Install the hood, left-, and right-side access panels.

12. Connect both battery cables to the battery making sure both are secure; then install the seat.

INSTALLING (6000)

1. Secure the starter motor using the existing four cap screws (B) (threads coated with blue Loctite #243). Tighten to 25 ft-lb.

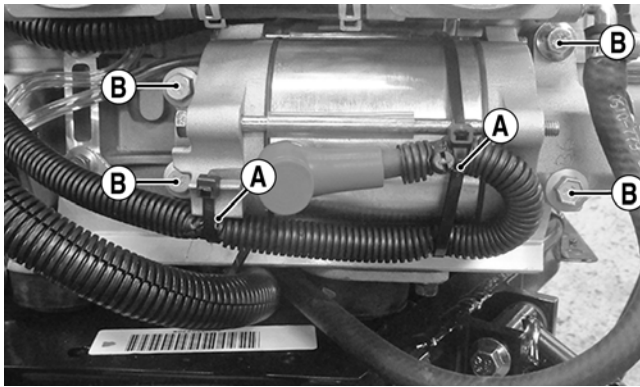

CWI-108A

2. Secure the positive battery cable to the starter motor using the existing nut. Tighten to 72 in-lb. Secure using a cable ties (A).
3. Install and position the intake boot; then secure the throttle body to the coolant lines using the existing clamps. Tighten securely.
4. Install the throttle body into the intake flanges and the intake boot. Secure using existing clamps.
5. Install the idle speed control (ISC) hoses (A) to the top of the throttle bodies; then secure the ISC using the screws (C). Connect the ISC to the main harness (B).

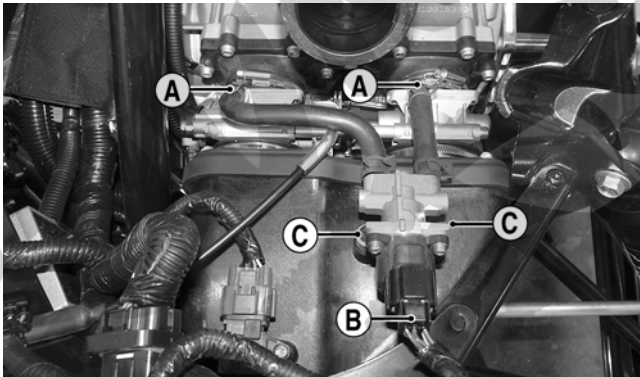

EL-006A

6. Position the shock mount bracket support and secure using the existing cap screws and nuts. Tighten to 20 ft-lb.



EL-003A

7. Secure the ECM and front facia assembly to the chassis using the existing self-tapping screws. Tighten securely.
8. Install the resonator and expansion chamber and secure using existing springs.
9. Install the hood, left-, and right-side access panels.
10. Connect both battery cables to the battery making sure both are secure; then install the seat.

Troubleshooting Electric Start

Problem: Hot or Smoking Wires

Condition	Remedy
1. System wired incorrectly	1. Check wiring against wiring diagram

Problem: Starter Does Not Turn Over

Condition	Remedy
1. Battery discharged	1. Check/charge the battery
2. Connection loose	2. Check tightness of all connections
3. Grounding improper	3. Check ground connections
4. Fuse blown - not installed	4. Check - replace fuse

Ignition Timing

■NOTE: The ignition timing is not adjustable, but on the 4000/8000 it can be checked and/or verified.

CHECKING

1. Connect a timing light to the MAG-side spark plug lead.
2. Using a shielded safety stand, raise the rear of the snowmobile off the floor and start the engine. Gradually increase the engine speed to 2000 RPM; with the engine warm the pointer should align with the proper timing mark on the flywheel.

BTDC - 16.5° - 0.072"

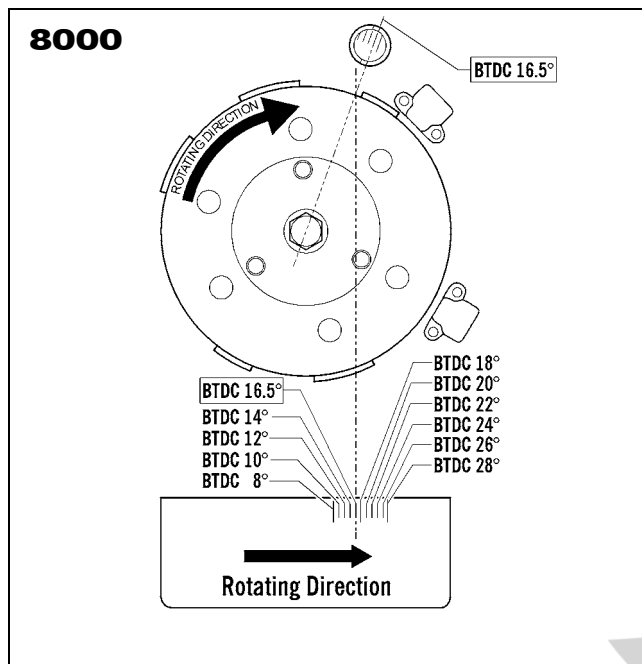

BTDC - 13° - 0.040"

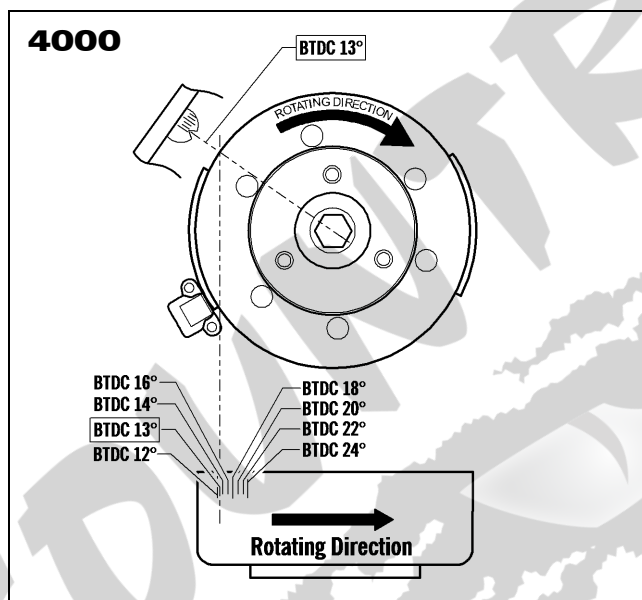

Brakelight Switch

TESTING/REMOVING

1. Disconnect the brakelight switch grey and brown two-wire connector (located near the brake lever).
2. To test the brakelight switch, connect one tester lead to the brown terminal; then connect the other lead to the black terminal.
3. With the brake lever compressed, the meter must read 1 ohm or less resistance. With the brake lever released, the meter must read OL (open). If the meter does not read as specified, the brakelight switch is defective and must be replaced.

4. To remove the switch, remove all brake fluid from the reservoir; then remove the torx-head screws securing the reservoir to the piston assembly; then pry the brake switch from the piston assembly.

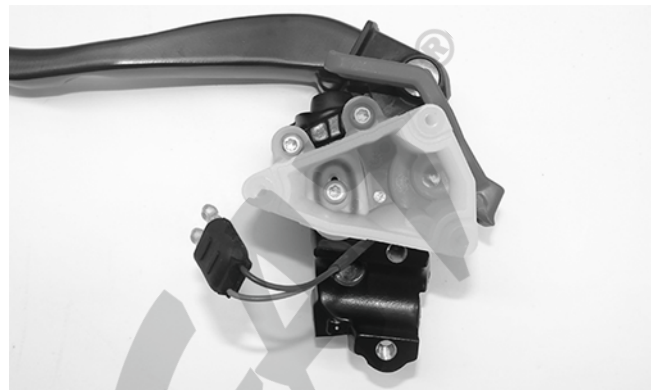

XM207



XM206

INSTALLING

1. Press the switch into the brake lever assembly making sure it is fully seated.
2. Position the O-ring into the reservoir; then secure the reservoir to the piston assembly using the existing screws. Tighten securely.
3. Connect the switch harness to the main wiring harness. Position the wires so they will not be either pinched or come in contact with any moving components. Start the engine and check the switch for proper operation.

Headlight Dimmer Switch

REMOVING/TESTING

1. Remove the four screws securing the left-side handlebar control assembly; then remove the control assembly from the handlebar.
2. Disconnect the HI/LO beam harness from the switch.
3. With the switch in the LO beam position, connect one ohmmeter lead to pin (A) and the other ohmmeter lead to pin (C). The meter must read 1 ohm or less resistance.

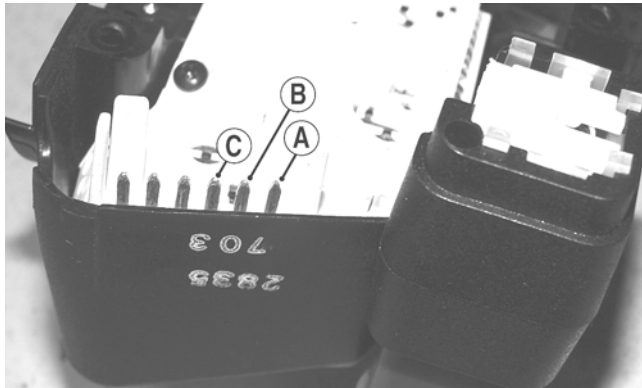

CM109A

4. With the switch in the HI beam position, connect one ohmmeter lead to pin (B) and the other ohmmeter lead to pin (C). The meter must read 1 ohm or less resistance.

■NOTE: If either test does not read within specification, replace the complete control assembly.

INSTALLING

1. Connect the HI/LO beam harness to the switch; then place the control assembly on the handlebar.
2. Secure with the four screws.

Testing Handlebar Warmer Elements

■NOTE: Resistance will vary due to temperature; therefore, this test should be made at room temperature of 20° C (68° F).

■NOTE: To access the element connectors, the handlebar control assembly for the side being tested must be removed.

1. Remove the handlebar pad (if applicable); then disconnect the handlebar warmer three-wire connector.
2. In the element connector, connect one ohmmeter lead to the green/white lead; then connect the other ohmmeter lead to the green lead.
3. The meter must read between 6.3-7.7 ohms.
4. In the element connector, connect the ohmmeter between the green/blue and green lead wires on the 2-stroke models or between the green/black and yellow lead wires on the 4-stroke models.
5. The meter must read between 12.6 and 15.4 ohms.
6. Replace any element measuring less than or more than the specified amount.

■NOTE: Repeat test for the other element.

7. Connect the leads; then install the handlebar control assembly and secure the handlebar pad (if applicable).

Testing Thumb Warmer Element

■NOTE: Resistance will vary due to temperature; therefore, this test should be made at room temperature of 20° C (68° F).

1. Remove the handlebar pad (if applicable); then disconnect the thumb warmer three-wire connector.
2. In the element connector, connect one ohmmeter lead to the green/white lead; then connect the other ohmmeter lead to the green lead.
3. The meter must read between 1.5 and 6.9 ohms.
4. In the element connector, connect the ohmmeter between the green/blue lead and the green lead on the 2-stroke models or between the green/black lead and the yellow lead on the 4-stroke models.
5. The meter must read between 5.5 and 23.0 ohms.

■NOTE: If either test is not within specification, replace the thumb warmer element.

6. Connect the leads; then install and secure the handlebar pad (if applicable).

Testing Handlebar Warmer/Thumb Warmer Switch

REMOVING/TESTING

1. Remove the four screws securing the left-side handlebar control assembly; then remove the control assembly from the handlebar.
2. Disconnect the handlebar/thumb warmer harness from the switch.
3. With the thumb warmer toggle in the low position, connect one ohmmeter lead to pin (C) and the other ohmmeter lead to pin (B). The meter must read 1 ohm or less resistance.

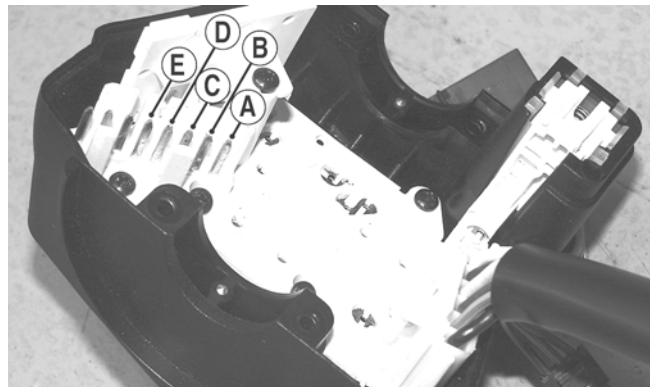

CM110A

4. With the thumb warmer toggle in the high position, connect one ohmmeter lead to pin (C) and the other ohmmeter lead to pin (A). The meter must read 1 ohm or less resistance.

■NOTE: If either test does not read within specification, replace the complete control assembly.

5. With the handwarmer toggle in the low position, connect one ohmmeter lead to pin (C) and the other ohmmeter lead to pin (D). The meter must read 1 ohm or less resistance.
6. With the handwarmer toggle in the high position, connect one ohmmeter lead to pin (C) and the other ohmmeter lead to pin (E). The meter must read 1 ohm or less resistance.

■NOTE: If either test does not read within specification, replace the complete control assembly.

INSTALLING

1. Connect the handlebar/thumb warmer harness to the switch; then place the control assembly on the handlebar.
2. Secure with the four screws.

Testing Speedometer Sensor

■NOTE: The following test should be made using MaxiClips and the Fluke Model 77 Multimeter set to the DC Volt scale.

■NOTE: Prior to testing the sensor, inspect the three-wire connector on the sensor harness for contamination, broken pins, and/or corrosion. With the engine running, note that a power supply of 10.8-14.4 DC volts exists at the main harness/speedometer connector.

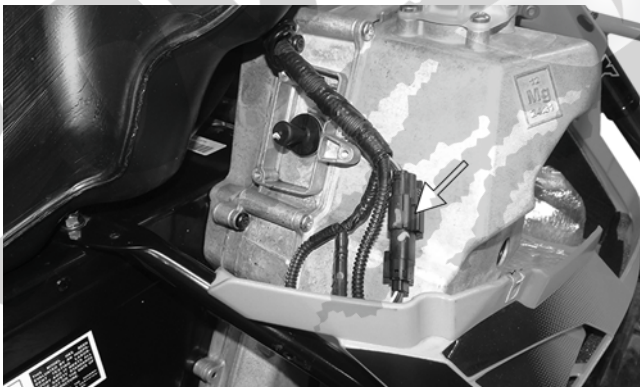

XM208A

1. Elevate the rear of the snowmobile onto a suitable safety stand.
2. Set the meter selector to the DC Voltage position.
3. At the sensor side of the plug-in, connect the red maxiclip and meter lead to the white/orange lead; then connect the black maxiclip and meter lead to the black lead.

4. Connect a positive 12-volt DC power supply to the red/blue wire; then connect a negative cable to the black wire from the main harness side of the plug-in.
5. Rotate the driven clutch. The meter must read 0 volts and 12 volts alternately.

Testing Shift Switch

■NOTE: The switch is located on the right-side handlebar control. To access the switch, the control assembly must be disassembled.

1. Disconnect the two-wire connector from the handlebar control.
2. Connect one ohmmeter lead to one pin; then connect the other ohmmeter lead to the other pin.

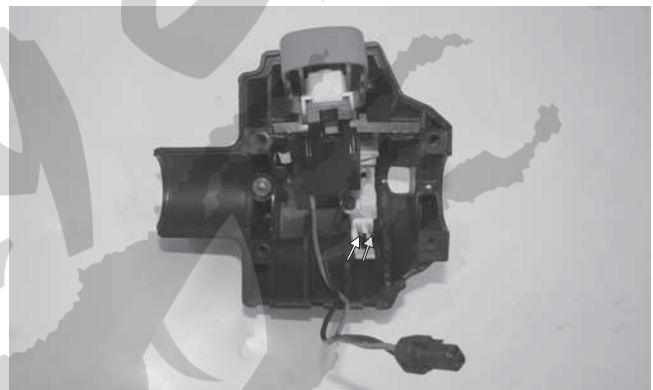

PC253B

3. With the reverse button pressed in, the meter must read less than 1 ohm of resistance. With the reverse button released, the meter must read OL (infinite resistance).

■NOTE: If the meter does not read as specified in either test, the switch is defective and must be replaced.

Testing Servomotor/Potentiometer

SERVOMOTOR

■NOTE: A 12-volt battery and test leads will be needed for this test.

1. Remove the servomotor from the snowmobile.

CAUTION

Care must be taken not to contact the servo yellow, orange, or black/white terminals, or damage to the potentiometer circuit will result.

2. Contact the red/black servo terminal with the battery positive lead; then contact the black/red servo terminal with the battery negative lead.

3. The servo should rotate when the negative lead contacts the black/red terminal. Note the direction of rotation.
4. Reverse the connections on the servo terminals: positive lead to black/red and negative lead to red/black. The servomotor should rotate in the opposite direction.
5. Install the servomotor.

■NOTE: If the servo operates correctly in the above test but fails to operate when connected to the ECM/regulator/rectifier at the designated RPM, proceed to Potentiometer test.

POTENTIOMETER

■NOTE: The following test should be made using MaxiClips and the Fluke Model 77 Multimeter set to the ohms scale.

1. Remove the servomotor from the snowmobile.
2. Connect the red maxiclip and meter lead to the black/white servo terminal; then connect the black maxiclip and meter lead to the yellow servo terminal.
3. Rotate the servo clutch counterclockwise. The ohms should increase as the clutch is rotated until it reaches 4700-5000 ohms.

4. Continue the clutch rotation, and there will be a small area in the rotation where the ohm reading will disappear; then it will return again.
5. Continue the clutch rotation, and the ohms should appear at a very low value but will again increase to 4700-5000 ohms. This is normal operation.



FZ088A

6. Install the servomotor.

■NOTE: If the servo operates correctly and the potentiometer test is correct but fails to operate when connected to the ECM/regulator/rectifier at the designated RPM, see Troubleshooting Servomotor chart in this section.

Troubleshooting Servomotor

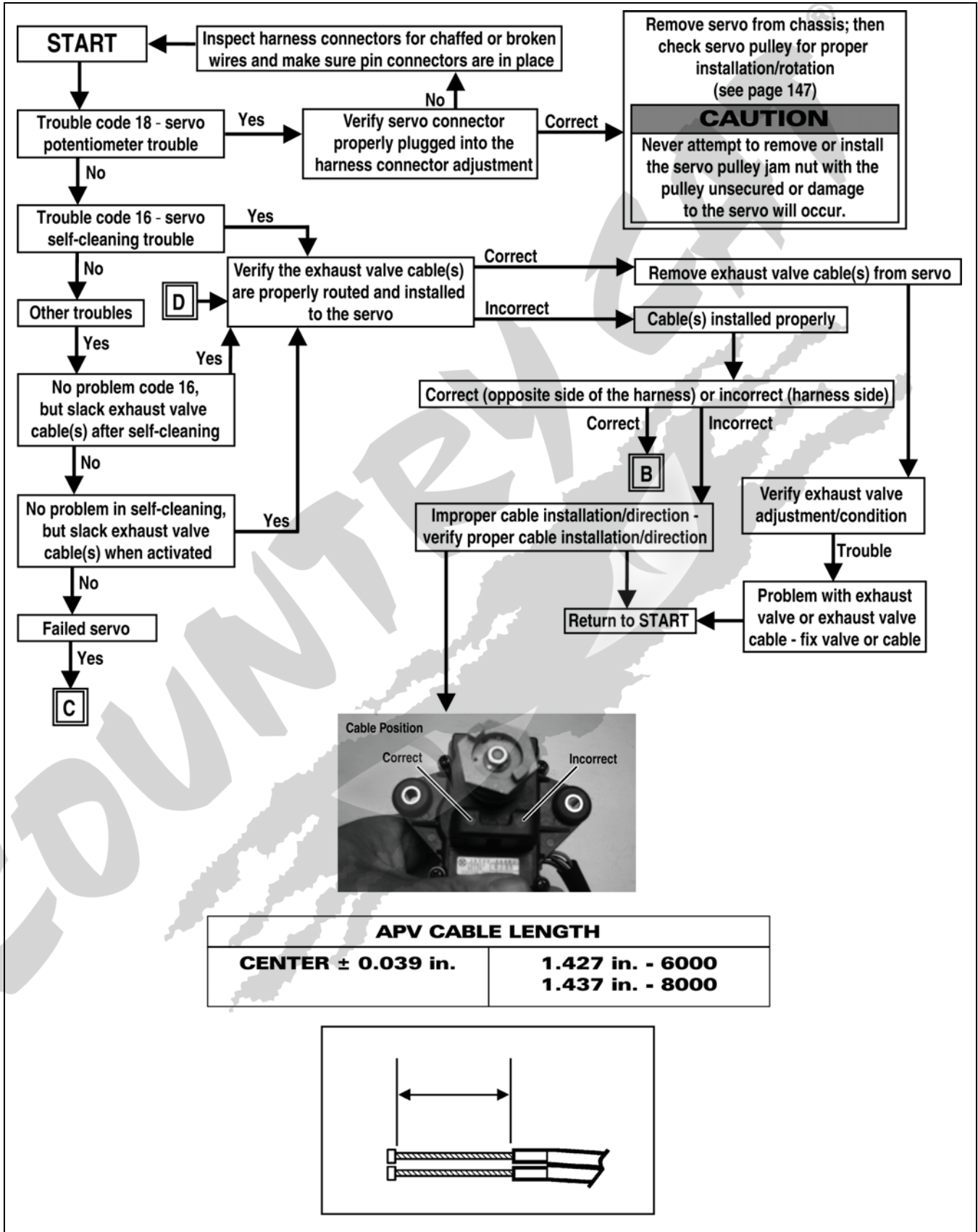

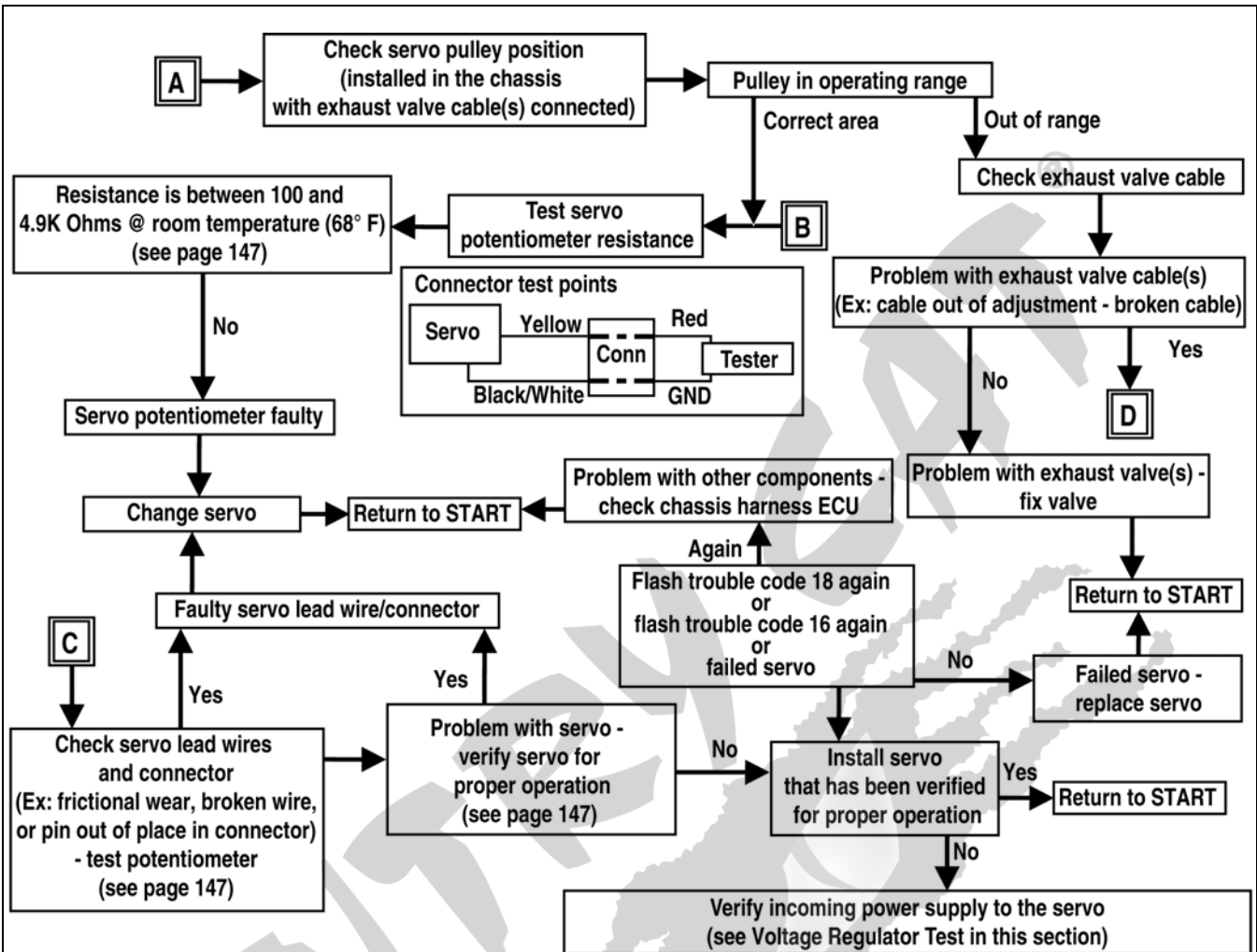

■ NOTE: When testing the servo potentiometer, use a large wrench on the pulley and rotate the pulley slowly making certain there are no open readings between the valve closed and valve open positions.



CAUTION
Never attempt to rotate the servo pulley using the pulley jam nut or damage to the servo may occur.

Voltage/Resistance Chart - Air Temperature (8000)

Temperature	Volts	Ohms	Temperature	Volts	Ohms		
100° C	212° F	0.113	555	28° C	82° F	1.230	8540
98° C	208° F	0.121	595	26° C	79° F	1.322	9530
96° C	205° F	0.128	635	24° C	75° F	1.413	10520
94° C	201° F	0.136	675	22° C	72° F	1.505	11510
92° C	198° F	0.143	715	20° C	68° F	1.596	12500
90° C	194° F	0.151	755	18° C	64° F	1.716	14020
88° C	190° F	0.162	819	16° C	61° F	1.836	15540
86° C	187° F	0.173	883	14° C	57° F	1.955	17060
84° C	183° F	0.184	947	12° C	54° F	2.075	18580
82° C	180° F	0.195	1011	10° C	50° F	2.195	20100
80° C	176° F	0.206	1075	8° C	46° F	2.323	23060
78° C	172° F	0.222	1160	6° C	43° F	2.452	26020
76° C	169° F	0.238	1245	4° C	39° F	2.580	28980
74° C	165° F	0.253	1330	2° C	36° F	2.709	31940
72° C	162° F	0.269	1415	0° C	32° F	2.837	34900
70° C	158° F	0.285	1500	-2° C	28° F	2.969	39940
68° C	154° F	0.308	1640	-4° C	25° F	3.101	44980
66° C	151° F	0.331	1780	-6° C	21° F	3.233	50020
64° C	147° F	0.353	1920	-8° C	18° F	3.365	55060
62° C	144° F	0.376	2060	-10° C	14° F	3.497	60100
60° C	140° F	0.399	2200	-12° C	10° F	3.610	76080
58° C	136° F	0.432	2410	-14° C	7° F	3.722	92060
56° C	133° F	0.465	2620	-16° C	3° F	3.835	108040
54° C	129° F	0.498	2830	-18° C	-0.4° F	3.947	124020
52° C	126° F	0.531	3040	-20° C	-4° F	4.060	140000
50° C	122° F	0.564	3250	-22° C	-8° F	4.142	156000
48° C	118° F	0.612	3595	-24° C	-11° F	4.224	172000
46° C	115° F	0.659	3940	-26° C	-15° F	4.306	188000
44° C	111° F	0.707	4285	-28° C	-18° F	4.388	204000
42° C	108° F	0.754	4630	-30° C	-22° F	4.470	220000
40° C	104° F	0.802	4975	-32° C	-26° F	4.522	261000
38° C	100° F	0.869	5490	-34° C	-29° F	4.574	302000
36° C	97° F	0.937	6005	-36° C	-32° F	4.625	343000
34° C	93° F	1.004	6520	-38° C	-36° F	4.677	384000
32° C	90° F	1.072	7035	-40° C	-40° F	4.729	425000
30° C	86° F	1.139	7550				

Voltage/Resistance Chart - Air Temperature (6000)

Temperature	Volts	Ohms	Temperature	Volts	Ohms		
100° C	212° F	0.68	182.6	28° C	82° F	3.03	1801
98° C	208° F	0.71	192.5	26° C	79° F	3.12	1943
96° C	205° F	0.74	202.9	24° C	75° F	3.21	2097
94° C	201° F	0.77	214.1	22° C	72° F	3.30	2265
92° C	198° F	0.81	225.9	20° C	68° F	3.38	2447
90° C	194° F	0.84	238.5	18° C	64° F	3.47	2636
88° C	190° F	0.88	251.9	16° C	61° F	3.56	2862
86° C	187° F	0.92	266.2	14° C	57° F	3.64	3118
84° C	183° F	0.97	281.6	12° C	54° F	3.72	3402
82° C	180° F	1.01	298.1	10° C	50° F	3.80	3714
80° C	176° F	1.06	315.7	8° C	46° F	3.88	4054
78° C	172° F	1.11	334.7	6° C	43° F	3.95	4425
76° C	169° F	1.16	355.0	4° C	39° F	4.02	4832
74° C	165° F	1.22	376.9	2° C	36° F	4.09	5280
72° C	162° F	1.27	400.4	0° C	32° F	4.16	5774
70° C	158° F	1.33	425.7	-2° C	28° F	4.22	6321
68° C	154° F	1.39	452.9	-4° C	25° F	4.28	6928
66° C	151° F	1.46	482.2	-6° C	21° F	4.34	7605
64° C	147° F	1.53	513.8	-8° C	18° F	4.39	8360
62° C	144° F	1.60	547.8	-10° C	14° F	4.44	9202
60° C	140° F	1.67	584.4	-12° C	10° F	4.49	10141
58° C	136° F	1.74	623.9	-14° C	7° F	4.53	11191
56° C	133° F	1.82	666.6	-16° C	3° F	4.57	12364
54° C	129° F	1.89	712.6	-18° C	-0.4° F	4.61	13675
52° C	126° F	1.97	762.3	-20° C	-4° F	4.64	15141
50° C	122° F	2.06	815.9	-22° C	-8° F	4.67	16780
48° C	118° F	2.14	874	-24° C	-11° F	4.70	18615
46° C	115° F	2.22	936.8	-26° C	-15° F	4.73	20672
44° C	111° F	2.31	1004	-28° C	-18° F	4.75	22980
42° C	108° F	2.40	1078	-30° C	-22° F	4.77	25572
40° C	104° F	2.49	1158	-32° C	-26° F	4.79	28486
38° C	100° F	2.58	1244	-34° C	-29° F	4.81	31769
36° C	97° F	2.67	1338	-36° C	-32° F	4.83	35471
34° C	93° F	2.76	1440	-38° C	-36° F	4.85	39650
32° C	90° F	2.85	1550	-40° C	-40° F	4.88	44373
30° C	86° F	2.94	1671				

Voltage/Resistance Chart - Coolant Temperature

Temperature	Volts	Ohms	Temperature	Volts	Ohms		
110° C	230° F	0.115	129	28° C	82° F	1.377	1800
108° C	226° F	0.129	137	26° C	79° F	1.459	1950
106° C	223° F	0.143	145	24° C	75° F	1.541	2100
104° C	219° F	0.157	153	22° C	72° F	1.623	2250
102° C	216° F	0.171	161	20° C	68° F	1.705	2400
100° C	212° F	0.185	169	18° C	64° F	1.806	2670
98° C	208° F	0.192	180	16° C	61° F	1.907	2940
96° C	205° F	0.199	191	14° C	57° F	2.008	3210
94° C	201° F	0.206	202	12° C	54° F	2.109	3480
92° C	198° F	0.213	213	10° C	50° F	2.210	3750
90° C	194° F	0.220	224	8° C	46° F	2.327	4170
88° C	190° F	0.235	240	6° C	43° F	2.444	4590
86° C	187° F	0.250	256	4° C	39° F	2.561	5010
84° C	183° F	0.265	273	2° C	36° F	2.678	5430
82° C	180° F	0.280	289	0° C	32° F	2.795	5850
80° C	176° F	0.295	305	-2° C	28° F	2.901	6510
78° C	172° F	0.317	327	-4° C	25° F	3.007	7170
76° C	169° F	0.339	349	-6° C	21° F	3.113	7830
74° C	165° F	0.361	371	-8° C	18° F	3.219	8490
72° C	162° F	0.383	393	-10° C	14° F	3.325	9150
70° C	158° F	0.405	415	-12° C	10° F	3.421	9422
68° C	154° F	0.438	445	-14° C	7° F	3.517	9694
66° C	151° F	0.471	475	-16° C	3° F	3.613	9966
64° C	147° F	0.504	505	-18° C	-0.4° F	3.709	10238
62° C	144° F	0.537	535	-20° C	-4° F	3.805	10510
60° C	140° F	0.570	565	-22° C	-8° F	3.885	13688
58° C	136° F	0.598	609	-24° C	-11° F	3.965	16866
56° C	133° F	0.626	653	-26° C	-15° F	4.045	20044
54° C	129° F	0.654	697	-28° C	-18° F	4.125	23222
52° C	126° F	0.682	741	-30° C	-22° F	4.205	26400
50° C	122° F	0.710	785	-32° C	-26° F	4.267	30520
48° C	118° F	0.759	849	-34° C	-29° F	4.329	34640
46° C	115° F	0.808	913	-36° C	-32° F	4.391	38760
44° C	111° F	0.857	977	-38° C	-36° F	4.453	42880
42° C	108° F	0.906	1041	-40° C	-40° F	4.515	47000
40° C	104° F	0.955	1105	-42° C	-44° F	4.553	55100
38° C	100° F	1.023	1214	-44° C	-47° F	4.591	63200
36° C	97° F	1.091	1323	-46° C	-51° F	4.629	71300
34° C	93° F	1.159	1432	-48° C	-54° F	4.667	79400
32° C	90° F	1.227	1541	-50° C	-58° F	4.705	87500
30° C	86° F	1.295	1650				

Drive Train/Track/Brake Systems

This section has been organized into sub-sections for servicing drive train, track, and brake systems; however, some components may vary from model to model. The technician should use discretion and sound judgment when removing and installing components.

■NOTE: Whenever a part is worn excessively, cracked, or damaged in any way, replacement is necessary.

SPECIAL TOOLS

A number of special tools must be available to the technician when servicing the drive train, track, and brake systems.

Description	p/n
Drive Clutch Bolt Tool	0644-281
Drive Belt Deflection Tool	0644-424
Bearing Removal and Installation Tool	0644-167
Movable Sheave Bearing Tool	0644-594
Clutch Alignment Bar	0644-428
Drive Clutch Puller	0744-062
Drive Clutch Spanner Wrench	0644-136
Driven Clutch Compressor Tool (4000 LXR/6000/8000)	0644-444
Driven Clutch Compressor Tool (4000 RR)	0644-439
Rear Suspension Spring Tool	0144-311
Brake Caliper Bearing Puller	0744-067

■NOTE: Special tools are available from the Arctic Cat Service Parts Department.

CAUTION

Never attempt to substitute any other drive clutch puller for the recommended puller or severe clutch damage will occur.

Drive Belt

If the drive belt is longer than specified, the drive clutch and driven clutch will not achieve full shift ratio. This will result in poor acceleration and a decrease in top speed.

If the drive belt is shorter than specified, the starting ratio will be higher causing the belt to slip. A too-short drive belt will cause a bog on engagement and will not allow the engine to reach peak RPM.

■NOTE: A thinly-worn drive belt may produce the same effect as one that is too long.

■NOTE: A stiff belt causes a HP loss to the track. As a belt warms up, it gets more flexible and transmits power with less HP loss.

■NOTE: When installing a new drive belt, see After Break-In Checkup - Drive Belt Break-In in the General Information section.

REMOVING (4000 LXR, 6000, 8000)

1. With the engine off, remove the left-side access panel. Loosen the 1/4 turn on the lower console.
2. Remove the cap screw, washers and sheave adjuster from the end of the driven clutch; then remove the cap screw, lock washer, and washer from the adjuster.

■NOTE: Assure that the shims and O-ring are not removed from the adjuster.

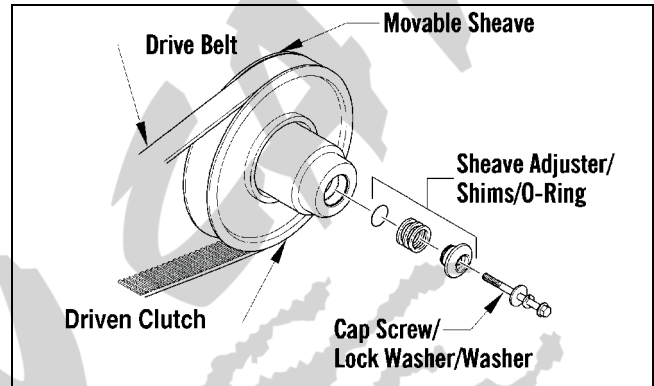

3. Reverse the adjuster and install the cap screw without washers into the adjuster. Install the sheave adjuster and cap screw onto the driven clutch; then tighten the cap screw until the movable sheave opens far enough to allow the belt to be removed.
4. Remove the drive belt from the driven clutch first; then from the drive clutch.

■NOTE: Each time the driven clutch cap screw is removed, the hole in the driven shaft should be cleaned free of any Loctite residue.

INSTALLING (4000 LXR, 6000, 8000)

CAUTION

Before securing the driven clutch, be sure the rollers are up against the torque bracket or damage to the back-side cams may occur.

1. Place the drive belt (so the arrow is pointing toward the front of the snowmobile) in the drive clutch; then between the sheaves of the driven clutch.
2. Install the sheave adjuster in its original position (beveled side out); then install the cap screw, lock washer, and washer into the driven clutch. Tighten the cap screw (threads coated with blue Loctite #243) to 20 ft-lb.
3. Secure the left-side console and access panel,

WARNING

Never operate the snowmobile without the belt guard/access panel secured in place.

Removing Drive Belt (ZR 4000 RR)

1. Set the brake lever lock; then remove the left-side access panel.

- Using Drive Belt Deflection Tool, thread the tool clockwise into the driven clutch until the movable sheave opens far enough to removing the drive belt.

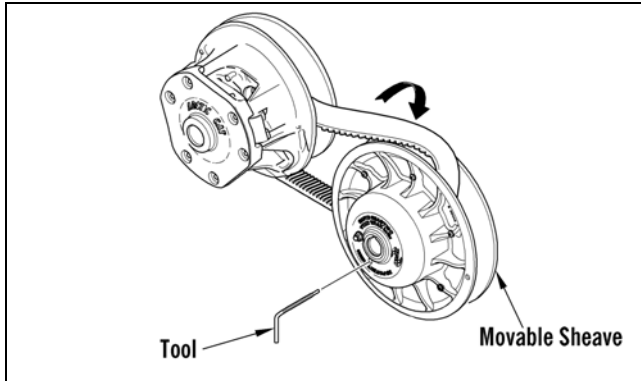

743-067B

Installing Drive Belt (ZR 4000 RR)

- Place the belt (so the part number can be read) between the sheaves of the drive clutch.
- With the sheaves fully apart, roll the belt over the stationary sheave.
- With the drive belt properly positioned in the drive clutch and driven clutch, turn the belt tool counter-clockwise, release the brake lever lock, and roll the belt back and forth to allow the driven clutch sheaves to fully close.
- After the belt is installed properly, install the left-side access panel.

Drive Clutch

CHANGING CAM ARMS/SPRINGS

Removing

- Using Drive Clutch Bolt Tool, remove the torx-head screw and lock washer securing the drive clutch to the crankshaft.

■NOTE: Before installing the clutch puller, apply oil to the threads of the puller and a small amount of grease to the tip of the puller.

- Using the Drive Clutch Puller and the Drive Clutch Spanner Wrench, tighten the puller. If the drive clutch will not release, sharply strike the head of the puller. Repeat this step until the clutch releases.
- Remove the drive clutch and drive belt from the engine compartment.

Disassembling

■NOTE: Note the timing marks on the cover, spider, and movable sheave. These must be aligned when assembling the drive clutch for balance purposes.

- Loosen the screws securing the cover. Remove every other cap screw and lock washer from the cover; then while firmly holding the cover, remove the three remaining screws and lock washers equally.

- Remove the cover and spring.

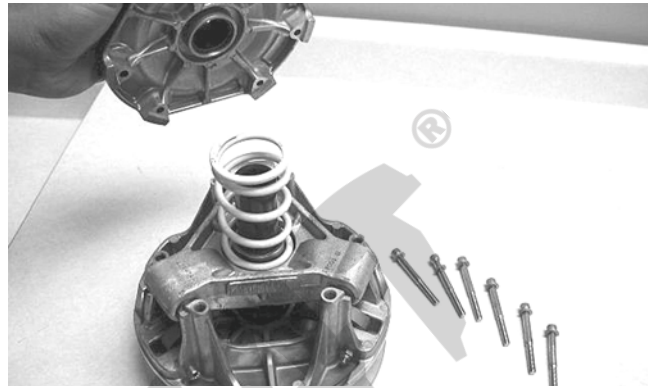

FC055

- Remove the cam arm pin lock nuts; then using a small torch, apply heat to the cam arm set screws to loosen the Loctite used in assembly.

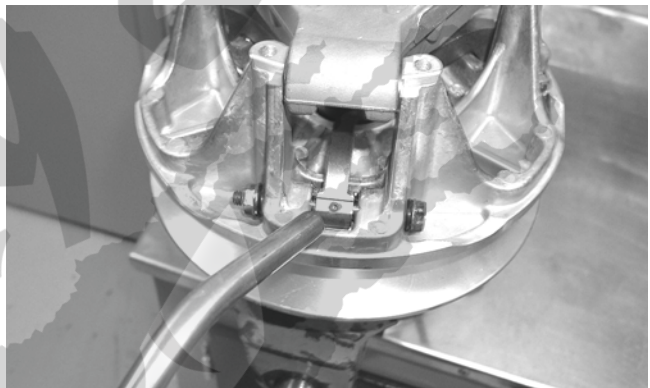

FS001

■NOTE: Heat must be applied to the cam arm in order to remove the set screws.

- After the set screws have been removed, remove the cam arm pins one at a time noting the position of the alignment notches in the cap screws for assembly purposes. Account for both O-rings.

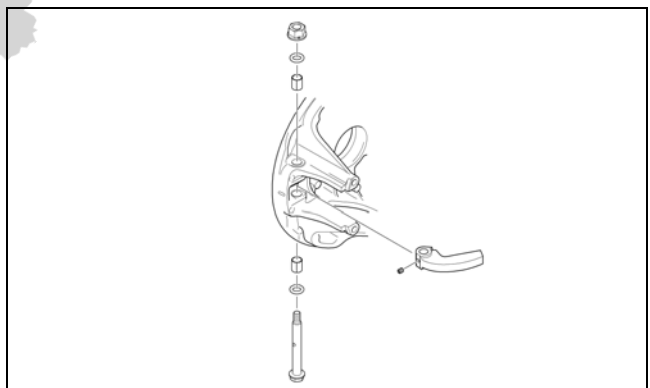

0739-038

Cleaning And Inspecting

1. Using parts-cleaning solvent, wash grease, dirt, and foreign matter off all components; dry with compressed air.

⚠ WARNING

Always wear safety glasses when using compressed air to dry components.

2. Remove any drive belt dust accumulation from the stationary sheave, movable sheave, and bushings using parts-cleaning solvent only.
3. Inspect stationary sheave, movable sheave, spider, and cover for cracks or imperfections in the casting.
4. Inspect the cam arm pins for wear or bends.
5. Inspect the spring for distortion, cracks, or wear.
6. Inspect rollers for damage or wear.

Assembling

1. With the head of each cam arm pin positioned towards the direction of the drive clutch rotation, install the cam arms.

■NOTE: The drive clutch rotates counterclockwise.

2. With the cam arm pin properly positioned, apply green Loctite #620 to the set screw holes in the cam arm, install the new set screws (pre-coated with Loctite), and tighten to 19 in.-lb.

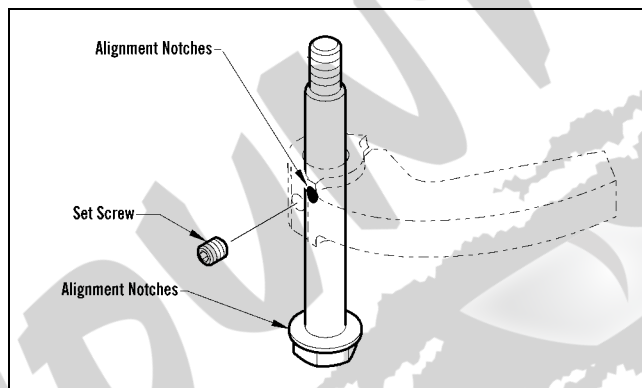

CAUTION

Green Loctite #620 must be applied to the set screw holes in the cam arms or component damage may occur.

3. Secure the cam arm pins with new lock nuts and tighten to 11 ft-lb.

CAUTION

When installing cam arms, always use new lock nuts and cam arm set screws.

4. Place the spring and cover into position making sure the timing mark on the cover is properly aligned; then compress the spring and install the screws coated with blue Loctite #243 and lock washers. In a crisscross pattern, tighten evenly to 120 in.-lb.



XM009A

CAUTION

Care must be taken when installing the cover not to damage the bushing.

Installing

■NOTE: Before installing the drive clutch, be sure to wipe both the crankshaft taper and clutch mounting taper clean using a clean towel.

1. Place the drive clutch into position on the crankshaft; then apply a few drops of oil to the threads of the cap screw.
2. Using Drive Clutch Spanner Wrench to hold the drive clutch, secure using the cap screw and high collar washer. Tighten to 51 ft-lb.

CAUTION

When installing the drive clutch, do not tighten the cap screw with any kind of impact tool. Tighten cap screw using a hand torque wrench only. Failure to do so could result in stationary sheave damage.

3. Check alignment between the drive clutch and driven clutch.
4. Install the drive belt. Check drive belt deflection. Close the left-side access panel.

■NOTE: For installing drive belt, see Drive Belt in this section.

⚠ WARNING

Never operate the engine without the belt guard/access panel secured.

5. Either test drive the snowmobile or run the engine for five minutes; then verify the drive clutch cap screw torque specification.

Driven Clutch

REMOVING - ZR 4000 LXR, 6000, 8000

1. Remove the left-side access panel; then remove the cap screw, washers, and sheave adjuster securing the driven clutch.

- Slide the driven clutch off the shaft.

■NOTE: Account for any alignment washers. These washers must be in place during installation.

DISASSEMBLING

- Place the driven clutch on the Driven Clutch Compressor Tool; then install the compressor flange and compress the driven clutch spring.
- Mark the moveable sheave, stationary sheave, and the torque bracket for assembly purposes.



XM139

- Apply heat to the screws securing the torque bracket to the movable sheave; then remove the screws.



XM140

■NOTE: Heat must be used to soften the Loctite using a torch or damage to the screw will occur.

- Release the compression of the spring by removing the wing nut; then remove the movable sheave.
- Remove the stationary sheave; then remove the plastic spring seat. Account for the driven spacer.



XM141

- Remove the spring and remaining spring seat.



PC112

CLEANING AND INSPECTING

- Using parts-cleaning solvent, wash grease, drive belt dust, and foreign matter off all components.

CAUTION

Do not use steel wool or a wire brush to clean driven clutch components. A wire brush or steel wool will cause the sheaves to be gouged (thus, the drive belt may not slide properly between sheaves). Decreased performance and possible accelerated drive belt wear will result.

- Inspect the rollers for damage, cracks, or wear.
- Inspect the sheaves for any gouges, cracks, or other damage. Also, inspect threaded areas of sheaves for damaged or stripped threads.
- Inspect the back-side cams and torque bracket for cracks or damage. The ramp portions of the bracket must be free of gouges and damage. Minor scratches may be repaired using #320 grit wet-or-dry sandpaper.
- Inspect spring for distortion, crystallization, or breaks.
- Inspect the cover and movable sheave bearing for wear. If wear is present, replace the bearing using Movable Sheave Bearing Tool.

REPLACING TORQUE BRACKET BEARING/COVER BEARING

- Remove the snap ring.

- Using Movable Sheave Bearing Tool, drive the bearing out.

⚠ WARNING

Always wear safety glasses when using the bearing driver.

- Install the new bearing using Movable Sheave Bearing Tool; then secure with a new snap ring.

REPLACING ROLLERS

- Bend the locking tabs down away from the shoulder bolt; then remove the bolt.



XM143

- Place a new roller into position and secure with the shoulder bolt (with a drop of red Loctite #271). Tighten securely and bend the lock tabs to contact the bolt head.

■NOTE: If the flat does not align with the tab, tighten the shoulder bolt until it aligns.



XM144A

ASSEMBLING

- Place the torque bracket onto the Driven Clutch Compressor Tool; then install the spring seat (flat side toward the spring) onto the torque bracket and place the spring into position.



PC112

■NOTE: Premature wear will result if the spring seat is not installed.

- Place the stationary sheave spring seat onto the spring (flat side toward the spring); then noting the alignment marks made during disassembling, place the stationary sheave onto the torque bracket.
- Place the movable sheave onto the stationary sheave.
- With the clutch in place on the compressor, install the compressor flange spacer and wing nut; then compress the driven clutch spring.



XM139

- With the driven clutch compressed, apply a small amount of green Loctite #620 to the machined area of the movable sheave so the Loctite can drip onto the threads of the torque bracket.



XM142

- Install new Screws securing the movable sheave. Tighten in a crisscross pattern to 27 ft-lb.



XM140

7. Remove the clutch from the compressor.
8. Install the back-side cams; then secure with the screws and tighten to 24 in.-lb.

INSTALLING

1. Set the brake lever lock.
2. Install the alignment washers; then install the driven clutch. Tighten to 20 ft-lb (threads coated with blue Loctite #243).
3. Check drive clutch/driven clutch alignment; then install the drive belt.

REMOVING - ZR 4000 RR

1. Remove the drive belt.
2. Remove the cap screw and washers securing the clutch; then slide the driven clutch off the shaft.

■NOTE: Account for any alignment washers. These washers must be in place during installation.

Disassembling

1. Remove the four torx head cap screws securing the cam to the movable sheave; then grasp the cam and by working the movable sheave back and forth, lift it up and off the shaft.



CM086



CM087

■NOTE: If changing cam angles, move the cam 90° to its optional position and secure the cam with the eight torx head cap screws. Tighten to 5-6 ft-lb.

2. Using Driven Clutch Compressor Tool, position the tool over the roller assembly; then compress the assembly enough to allow the snap ring to be removed from the end of the shaft. Remove the snap ring.

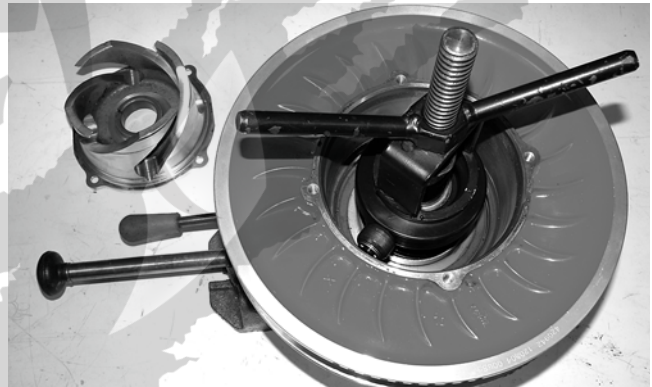

CM088

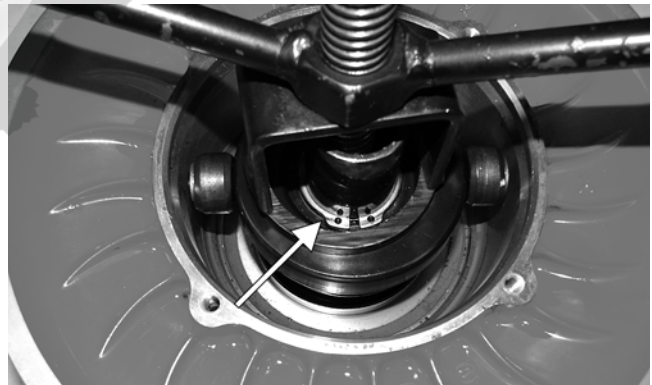

CM089A

■NOTE: It is advisable to secure the compression tool in a vise or to bolt it to a sturdy workbench.

3. Remove the compression tool and account for the snap ring, spider assembly, spring, and a retaining ring.

■NOTE: Note the location of the "X" stamped on the roller assembly for assembling purposes.

- Remove the movable sheave from the driven clutch shaft and account for one spacer.

Cleaning And Inspecting

- Using a parts-cleaning solvent, wash grease, dirt, and foreign matter off all components; dry with compressed air.
- Remove any drive belt dust accumulation from the stationary sheave, movable sheave, and bushings using parts-cleaning solvent only.

CAUTION

Do not use steel wool or a wire brush to clean components having a bushing; damage to the bushing will result.

- Inspect the roller assembly for wear or damage.

NOTE: Flat spots or diameter cannot be less than 23 mm (0.925 in.).

- Inspect shaft for nicks or burrs.

- Using a spring compression scale, measure spring rate at proper load heights (secondary springs measured at load heights of 2.2 in. and 1.1 in.).

NOTE: If a spring rate measures less than 10% of specified load height, it must be replaced.

- Measure the inside diameter of the movable sheave bushing. Bushing to shaft clearance must not exceed 0.25 mm (0.010 in.).

NOTE: If clearance exceeds the limit, the bushing must be replaced.

Assembling

- Install the spacer and the movable sheave onto the driven clutch shaft.
- Place the retaining ring and spring into the driven clutch; then place the roller assembly and snap ring over the spring.



FS031

- Position the roller assembly so the "X" mark is directly in line with the keyway on the driven clutch shaft.

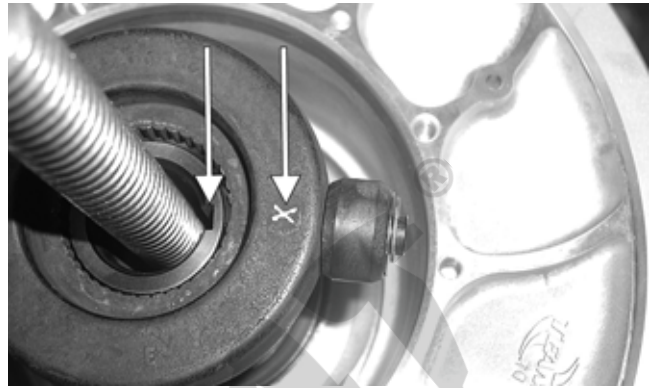

FS033A

- With Driven Clutch Compressor Tool, compress the roller assembly enough to allow the snap ring to be properly secured to the shaft.



CM090

NOTE: While compressing the roller assembly, it may be necessary to work the spider assembly back and forth to properly mate the splines.

- With the "X" mark on the movable sheave lined up with the "X" mark on the roller assembly, place the cam with the desired angle into position; then secure the cam to the movable sheave with the four torx head cap screws. Tighten to 5-6 ft-lb.



CM091B

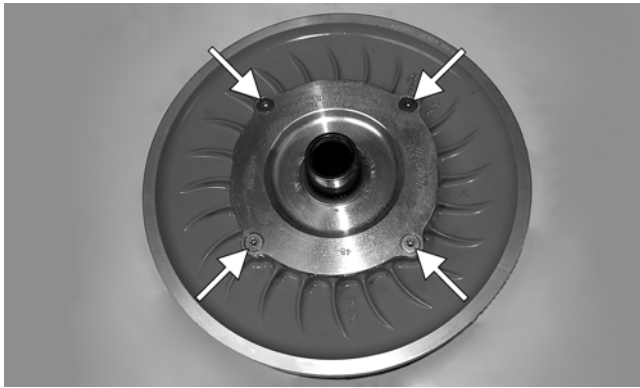

CM086A

Installing

1. Slide the alignment washers onto the end of the driven shaft.
2. Install the key in the driven shaft keyway; then place the stub shaft into the driven clutch. Place the driven clutch on the shaft. Align its keyway with the driven shaft keyway.

■**NOTE:** A small amount of Loctite Anti-Seize Thread Compound (p/n 0678-146) applied to the driven shaft will aid in future driven clutch removal.

3. Secure the driven clutch by installing the washer and cap screw (threads coated with blue Loctite #243). Tighten the cap screw to 20 ft-lb.

Drive Clutch/Driven Clutch

If premature drive belt wear is experienced or if drive belt turns over, check parallelism/offset. Also, parallelism/offset must be checked whenever either drive clutch or driven clutch is serviced. To check offset, use appropriate Clutch Alignment Bar. To check parallelism, use Parallelism Bar.

CHECKING OFFSET (ZR 4000 LXR, 6000, 8000)

1. With the engine off, open the left-side access panel; then remove the drive belt.
2. Install appropriate Clutch Alignment Bar between the drive clutch sheaves.
3. Allow the bar to rest on the drive clutch shaft and against the outside edge of the driven clutch stationary sheave.

■**NOTE:** The alignment bar must extend beyond the front edge of the drive clutch.

4. With the bar against the outside edge of the driven clutch stationary sheave at points A and B, the bar should just clear the inside edge of the stationary sheave of the drive clutch and rest on the stationary shaft at point C. If the bar either will not clear the inside edge or is more than the specified amount, the offset must be corrected.

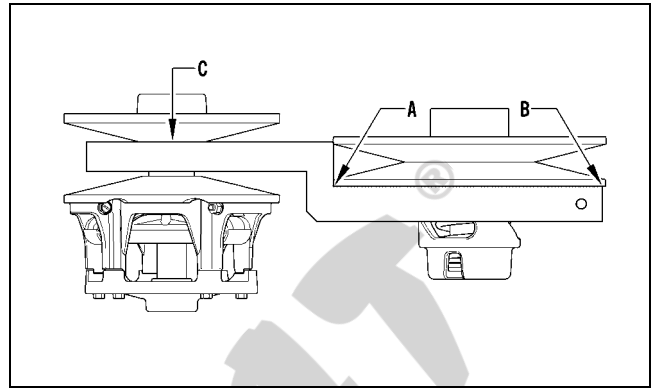

0747-959

CORRECTING OFFSET (ZR 4000 LXR, 6000, 8000)

1. To correct offset, the driven clutch must be moved laterally on the input shaft. Remove the cap screw and washers securing the driven clutch.

■**NOTE:** If the driven clutch is tight on the shaft, pull the driven clutch off using the Driven Clutch Puller.

2. To move the driven clutch inward on the shaft, remove alignment washers located on driven shaft from the chain case of the clutch.
3. To move the driven clutch outward on the shaft, add alignment washers to the driven shaft on the chain case of the clutch.
4. Arrange washers to obtain correct offset; then install driven clutch, cap screw, and washers.
5. Install the drive belt.

DRIVE BELT DEFLECTION (ZR 4000 LXR, 6000, 8000)

Drive belt length, condition, and deflection are all important for peak performance. To check and adjust drive belt deflection, use the following procedure.

■**NOTE:** Make sure the drive belt is sitting at the top of the driven clutch sheaves.

1. Place a straightedge on top of the drive belt. The straightedge should reach from the drive clutch to the top of the driven clutch.
2. Using a stiff ruler centered between the drive clutch and driven clutch, push down on the drive belt just enough to remove all slack. Note the amount of deflection on the ruler at the bottom of the straightedge. The deflection should be at 1 1/4 in.

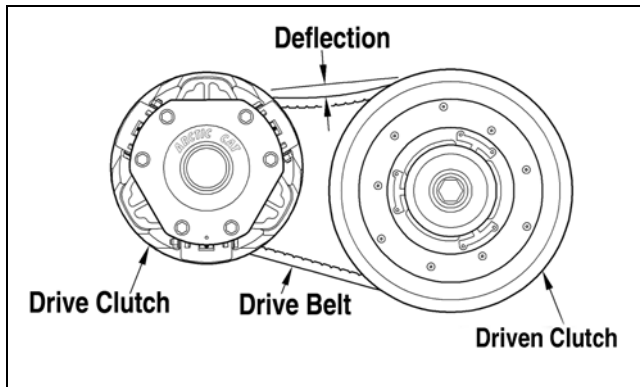

0743-319

■NOTE: Push down on the belt with the ruler only until the bottom of the belt flexes upward; then read the amount of deflection.

3. To correct drive belt deflection, remove the sheave adjuster from the clutch, remove or add shim washers to the adjuster, and install the adjuster.

■NOTE: After any adjustment have been made, make sure the drive belt is sitting at the top of the driven sheaves. Support the rear suspension up in the air; then run the sled for a few seconds and let the track slow down to a stop. Turn the engine off and check deflection again. Adjust as necessary.

■NOTE: Adding shim washers will decrease belt deflection; removing shim washers will increase belt deflection.

CHECKING/ADJUSTING DEFLECTION - ZR 4000 RR

Drive belt length, condition, and deflection are all important for peak performance. To check and adjust drive belt deflection, use the following procedure.

1. With the engine off; remove the hood and left-side access panel.
2. Make sure the drive belt is sitting at the top of the driven clutch sheaves.
3. Place a straightedge on the top of the drive belt. The straightedge should reach from the drive clutch to the top of the driven clutch.
4. Using a stiff ruler centered between the drive clutch and driven clutch, push down on the drive belt just enough to remove all slack and note the amount of deflection. The deflection should be approximately 15.9-22.2 mm (5/8-7/8 in.).

■NOTE: The amount of deflection should be experimented with or tested to obtain best start-line performance.

■NOTE: Push down on the belt with the ruler only until the bottom of the belt flexes upward; then read the amount of deflection.

5. To correct drive belt deflection, loosen the jam nut on the belt width adjuster on the stationary sheave.

6. Using an Allen wrench, adjust the set screw as needed.

■NOTE: Turning the set screw clockwise increases distance between the sheaves (increases belt deflection measurement); turning the set screw counterclockwise decreases distance between the sheaves (decreases belt deflection measurement).

Drive Train

REMOVING CHAIN CASE/DRIVEN SHAFT/DRIVESHAFT/TRACK (4000 RR, 6000, 8000)

1. Remove the left- and right-side panels, hood; then loosen the quarter turns securing the lower console to the skid panels and secure out of the way.
2. Remove the drive and driven clutches.
3. Remove the screws securing the PTO engine mount plate to the engine and the chassis.
4. Remove the resonator; then remove the right-side footrest.
5. Remove the torx-head screw securing the belly pan to the right-side footrest support.
6. Disconnect the speed sensor connector and the oil level connector.
7. Place a drain pan under the chain case; then loosen the eleven screws securing the chain case cover/oil tank assembly to the chain case housing starting with the bottom screws first.
8. Remove the chain case cover/oil tank and set out of the way leaving the oil hose(s) connected.
9. Release tension on the chain tensioner; then remove the ratchet block and the tensioner.

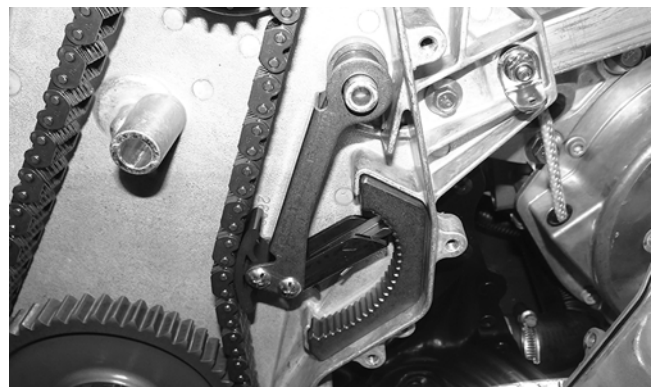

XM259

10. Remove the snap ring securing the upper sprocket to the driven shaft.

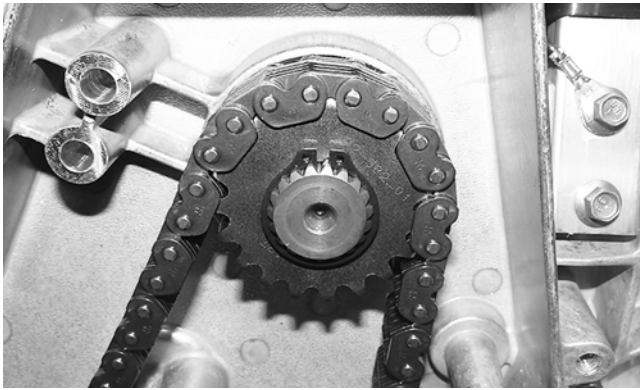

XM262

■NOTE: Spread the snap rings only enough to remove them from the drive and drive shafts.

11. Remove the snap ring securing the lower sprocket. Remove the sprockets and chain.

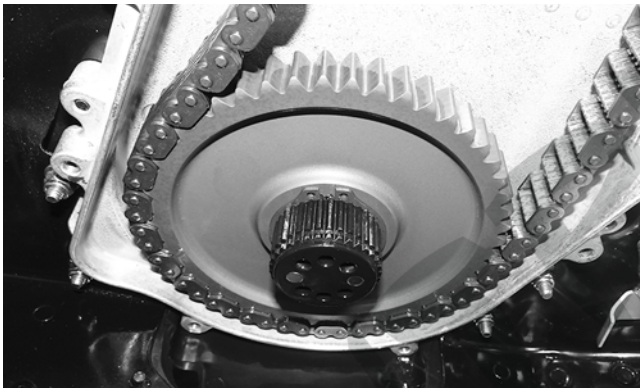

XM261

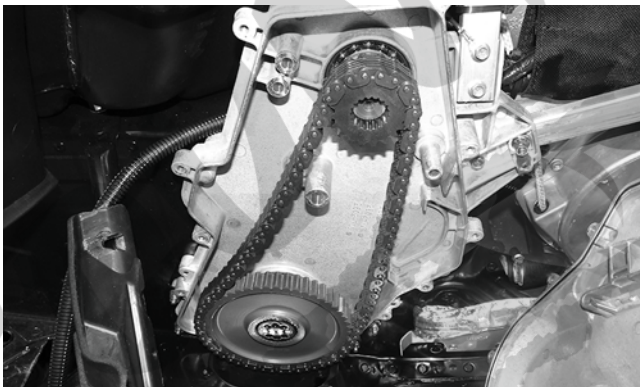

XM263

12. Remove the inner black snap ring; then remove the snap ring and washer securing the driven shaft.

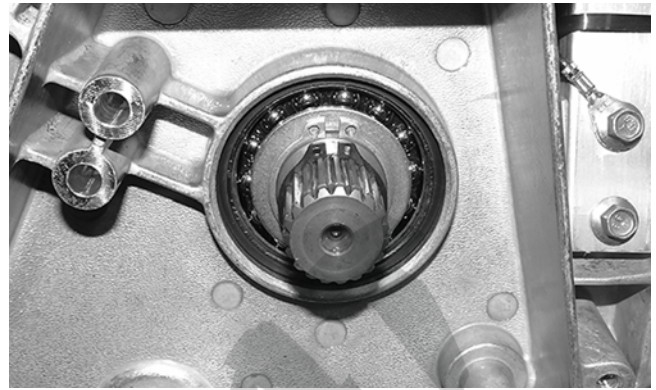

XM264

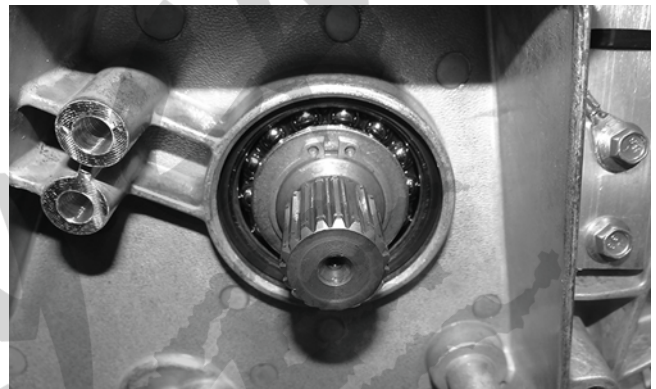

XM265

13. Once the snap ring and washers have been removed from the driven shaft, the shaft and PTO engine mount plate may be removed from the chassis. Make sure to keep the shaft 90° to the plate.

14. Remove the skid frame assembly.

15. Remove the brake shield and the left-side footrest.

■NOTE: DO NOT split the brake caliper unless necessary service work is required.

16. Remove the cap screws securing the inner caliper to the tunnel; then remove the caliper and the driveshaft assembly.

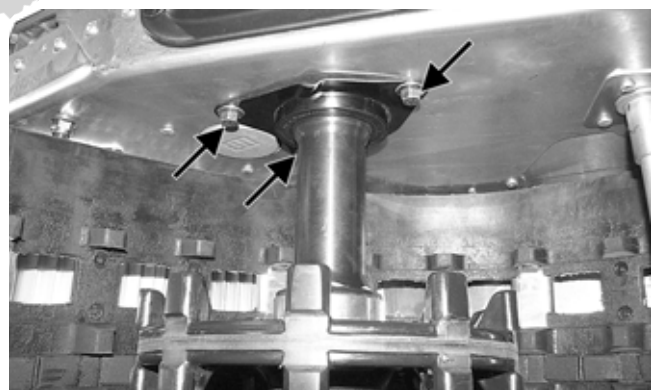

PC148A

■NOTE: If the caliper will not slide off the driveshaft easily, proceed to step 17.

17. Remove the retaining pin and the brake disc pads; then pump the brake lever 3 or 4 times then pull back and secure the lever to the handlebar using a cable tie. This will keep the fluid from leaking.

■NOTE: Place an absorbent towel under the caliper to absorb slight amount of brake fluid. Do not compress the brake lever.

18. Remove the retaining ring securing the brake disc to the driveshaft and remove the brake disc.

■NOTE: It may be necessary to use Brake Caliper Bearing Puller to remove the caliper/bearing assembly.

■NOTE: If the chain case needs to be removed, remove all machine screws with lock nuts.

CLEANING AND INSPECTING CHAIN CASE

1. Inspect sprockets and chain for excessive wear or stretching.
2. Inspect bearings and sprockets for roughness or chipping.

■NOTE: If bearing replacement is necessary, the chain case must be removed from the tunnel and an appropriate press utilized to remove and install bearings.

3. Clean all interior chain case surfaces and components in cleaning solvent and dry using compressed air.

⚠ WARNING

Always wear safety glasses when using compressed air.

ASSEMBLING/INSTALLING CHAIN CASE/DRIVEN SHAFT/DRIVESHAFT/TRACK

If the driveshaft and driven shaft were not removed, proceed to step 12.

1. Install chain case assembly onto the chassis and secure with the machine screws and four lock nuts. Tighten all screws to 12 ft-lb.
2. Place the driveshaft/drive sprocket assembly into the tunnel brake-end first; then into the chain case drive-shaft bearing.
3. Install the inner brake caliper assembly and secure with three cap screws and the retaining ring. Tightened cap screws (threads coated with blue Loctite #243) securely.

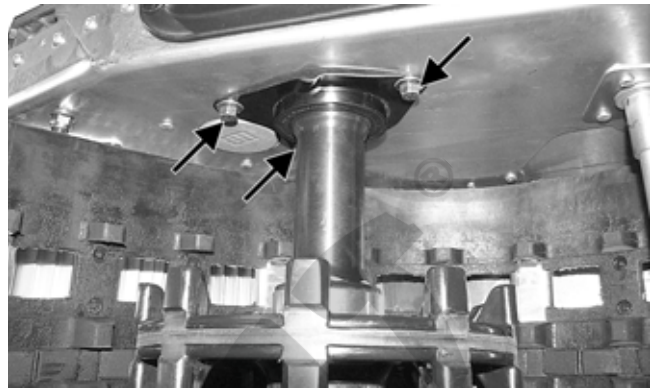

PC148A

■NOTE: If the brake caliper was split, proceed to step 4. If not, proceed to step 6.

4. Install the brake disc and secure with the retaining ring.
5. Making sure the seal is correctly installed in the outer brake caliper, install on the inner caliper and secure with two cap screws. Tighten to 25 ft-lb.

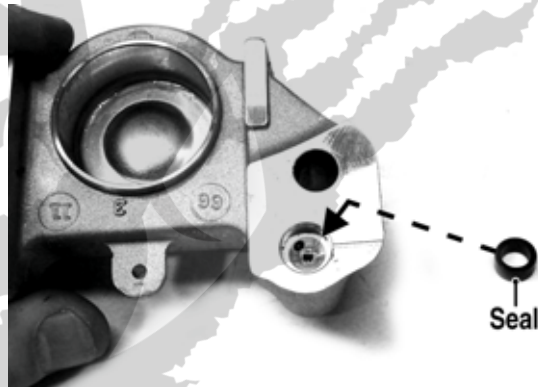

PC173A

6. Install the skid frame (see the Suspension section).
7. Install the brake shield and left-side footrest. Tighten the cover cap screws to 8 ft-lb.

■NOTE: Remove the cable tie securing the brake lever; then pump the break lever until the brake lever feels firm when compressed. To verify lever travel, compress and hold the brake lever to its maximum resistance; then measure the distance between the brake lever and the handlebar. The distance must be greater than 1 in.

8. Install the driven shaft w/mount plate from the left-side; then secure the PTO-side engine mounting plate to the crankcase and the chassis with the existing cap screws (coated with blue Loctite #243) and one washer. Tighten to 30 ft-lb.

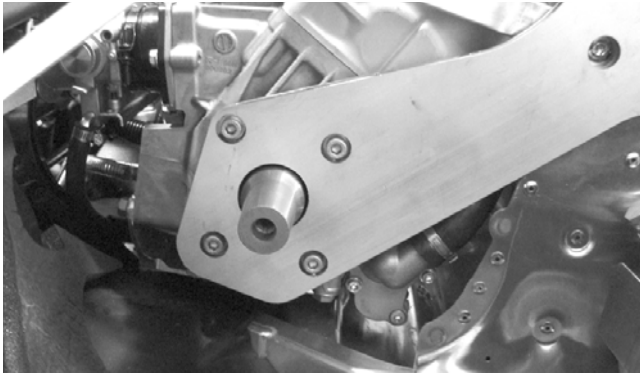

PC181

9. Install the drive clutch and tighten the clutch cap screw w/washer to 51 ft-lb; then install the driven clutch and drive belt. Tighten to 20 ft-lb.
10. Install the existing washers; then press in on the driven shaft and secure the shaft using the existing washers and snap ring.

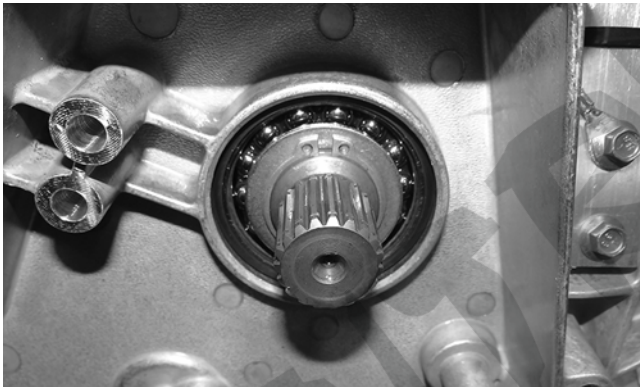

XM265

11. Install the black snap ring onto the inner snap ring groove in the driven shaft.

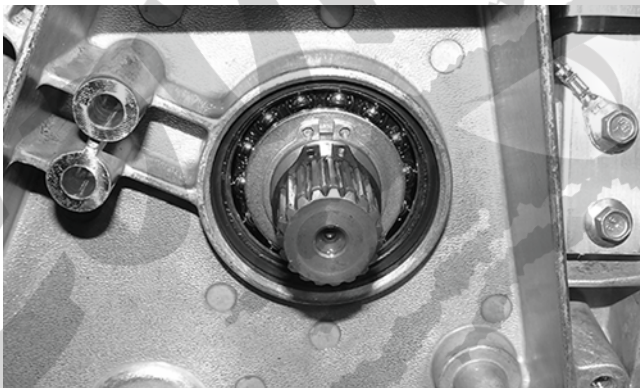

XM264

12. Install the sprockets and chain onto the driveshaft and driven shaft and secure using the existing snap rings.



XM261

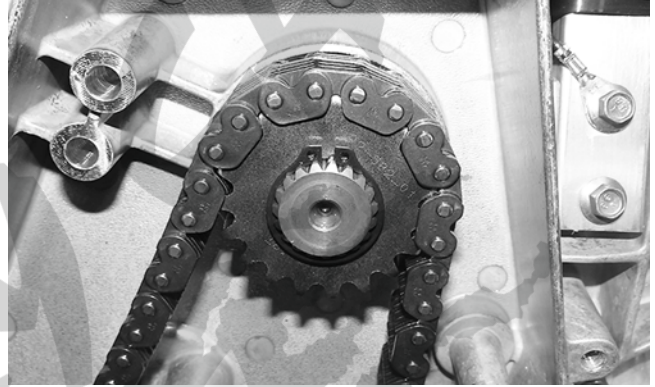

XM262

13. Install the ratchet block and tensioner; then set the tensioner in the fifth notch in the block as it is self tightening.

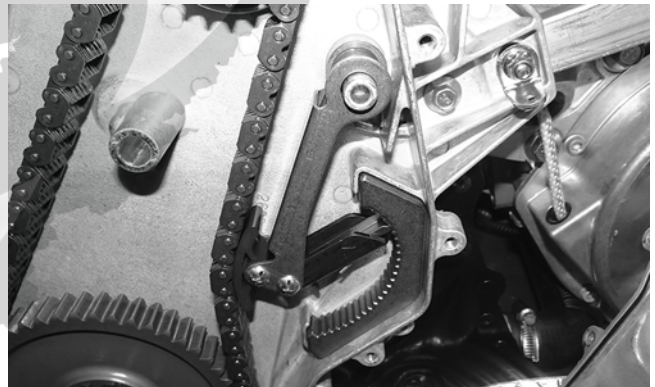

XM202

14. Install the chain case cover/oil tank assembly and secure with the existing screws (threads coated with blue Loctite #243). Tighten in a crisscross pattern to 12 ft-lb. Fill the chain case with 15 oz. of Arctic Cat Chain Lube.
15. Connect the speed and oil sensor connector.
16. Install the right-side footrest support and secure to the belly pan using the existing screws.
17. Install the resonator.
18. Secure the lower console to the skid panels; then install the hood and both access panels.

REMOVING CHAIN CASE/DRIVEN SHAFT/DRIVESHAFT/TRACK (4000 LXR)

1. Remove the left- and right-side panels, hood; then loosen the quarter turns securing the lower console to the skid panels and secure out of the way.
2. Remove the drive and driven clutches.
3. Remove the screws securing the PTO engine mount plate to the engine and the chassis.
4. Remove the resonator; then remove the right-side footrest.
5. Remove the torx-head screw securing the belly pan to the right-side footrest support.
6. Disconnect the speed sensor connector and the oil level connector.
7. Place a drain pan under the chain case; then loosen the eleven screws securing the chain case cover/oil tank assembly to the chain case housing starting with the bottom screws first.
8. Remove the chain case cover/oil tank and set out of the way leaving the oil hose(s) connected. Account for a thrust washer on the countershaft.

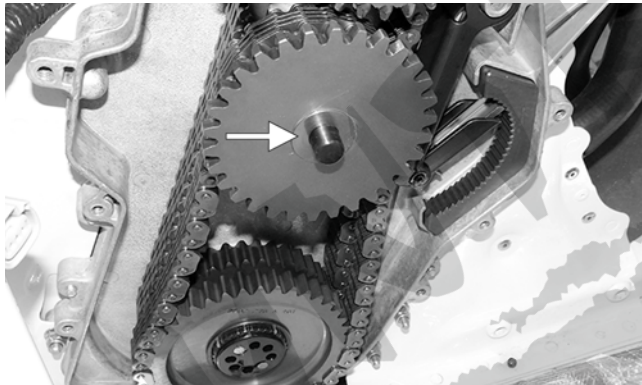

SNO-964A

9. Remove the reverse gear, reverse fork, reverse shift rack, and the reverse shift shaft as an assembly.
10. Remove the retaining ring from the driveshaft; then remove the reverse chain and sprockets. Account for a thrust washer.

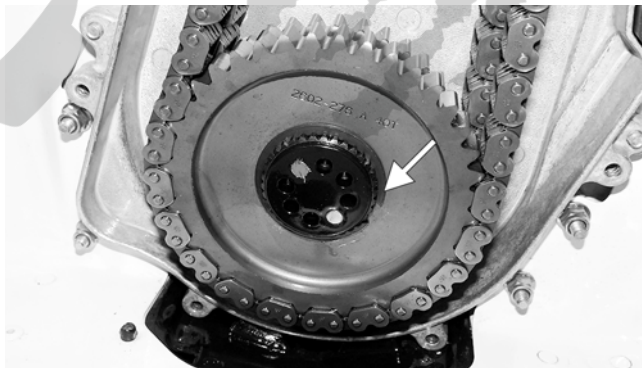

SNO-965A

11. Release tension on the chain tensioner; then remove the ratchet block. The tensioner does not need to be removed.

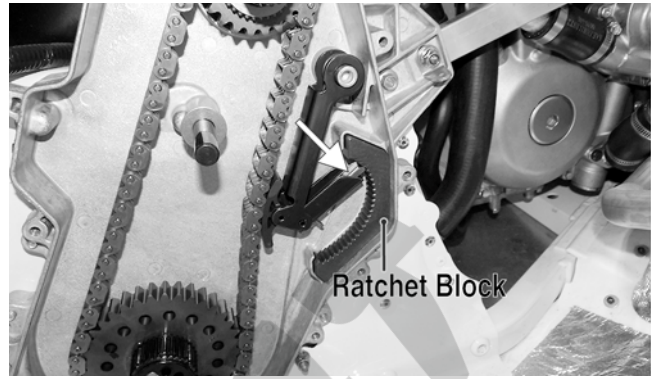

SNO-966A

12. Remove the sprockets and chain.

CLEANING AND INSPECTING CHAIN CASE

1. Inspect sprockets and chains for excessive wear or stretching.
2. Inspect bearings and gears for roughness or chipping.

■ **NOTE:** If bearing replacement is necessary, the chain case must be removed from the tunnel and an appropriate press utilized to remove and install bearings.

3. Inspect reverse shift rack and fork for excessive wear, discoloration, or other damage.
4. Clean all interior chain case surfaces and components in cleaning solvent and dry using compressed air.

⚠ WARNING

Always wear safety glasses when using compressed air.

5. Inspect chain snubbers for excessive wear.

ASSEMBLING/INSTALLING CHAIN CASE/DRIVEN SHAFT/DRIVESHAFT/TRACK

If the driveshaft and driven shaft were not removed, proceed to step 16.

1. Install chain case assembly onto chassis and secure with six self-tapping screws and four machine screws with lock nuts. Tighten the screws to 14 ft-lb.
2. Place the driveshaft/drive sprocket assembly into the tunnel brake-end first; then into the chain case drive-shaft bearing.
3. Install the inner brake caliper assembly and secure with three cap screws and the retaining ring. Tighten the cap screws securely.

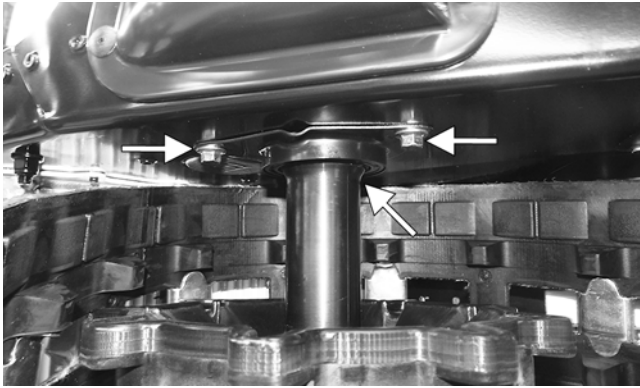

YM-077A

■NOTE: If the brake caliper was split, proceed to step 4. If not, proceed to step 6.

4. Install the brake disc and secure with the retaining ring.
5. Making sure the seal is correctly installed in the outer brake caliper, install on the inner caliper and secure with two cap screws. Tighten to 25 ft-lb.

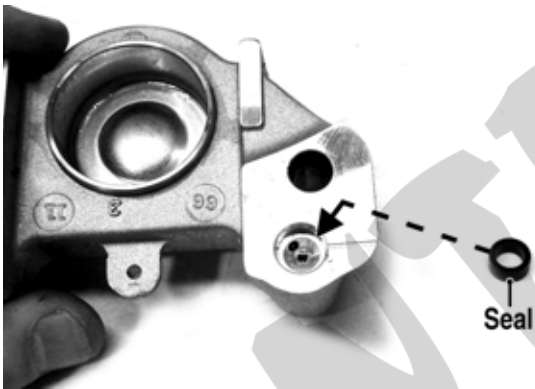

PC173A

6. Install the skid frame.
7. Install the brake cover and left-side footrest. Tighten the cover cap screws to 8 ft-lb.

■NOTE: Bleed the brake system if the brake caliper was split in this section.

8. Install the chain and sprockets; then install the ratchet block making sure to have the tensioner on the fifth notch.

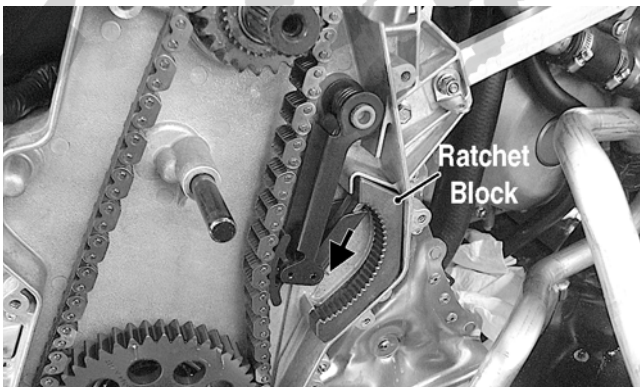

PC085A

9. Install the reverse sprockets and chain.

10. Secure the driveshaft reverse sprocket to the drive-shaft with a retaining ring; then install a existing thrust washer on the outside of the upper reverse sprocket and reverse idler shaft.



SNO-965A



SNO-973A

20. Install the reverse gear, fork, shift shaft, and shift rack assembly into the chain case.

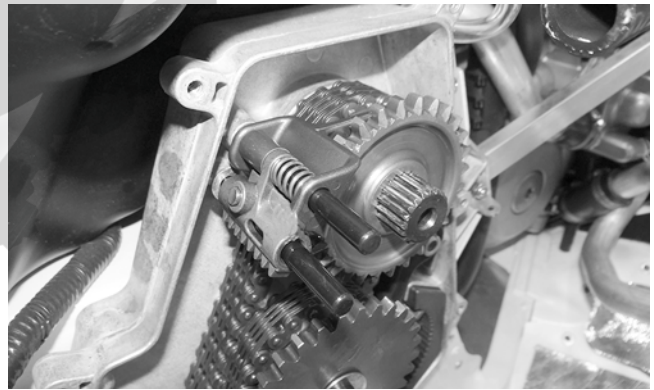

SNO-979

21. Install the chain case cover/oil tank assembly and secure with the screws. Tighten in a crisscross pattern to 105 in.-lb.
22. Fill the chain case with 12 oz of Arctic Cat Chain Lube.
23. Install the actuator extender; then install the reverse actuator and with a drop of blue Loctite #243 on each screw, secure the actuator to the chain case cover.
25. Connect the speed sensor connector (A), the gear indicator switch connector (B), and reverse actuator connector (C).

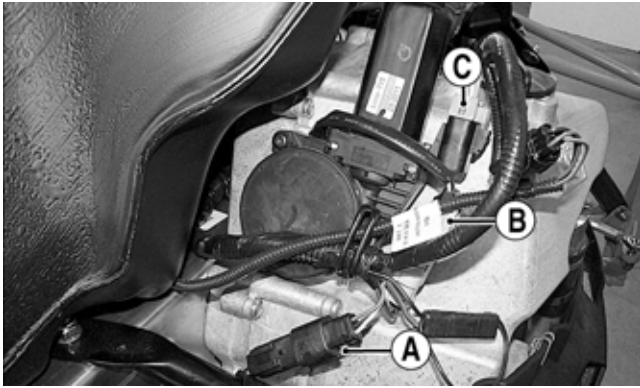

PC067A

27. Install the right-side footrest support and secure to the belly pan using the torx-head screw; then install the right-side footrest.
28. Install the seat.
29. Start the engine and with the snowmobile on a jack stand; then shift the snowmobile into and out of reverse three times.

Drive Sprockets

REMOVING

■NOTE: The drive sprockets must be removed from the brake side.

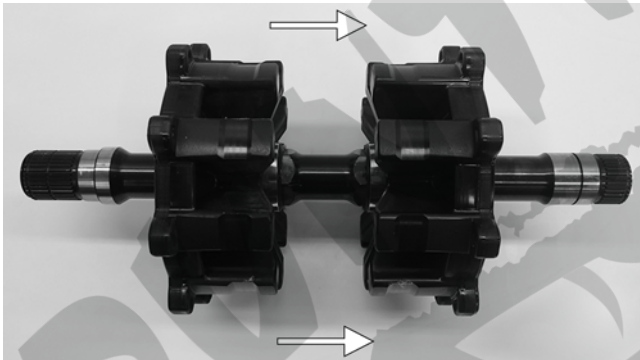

YM-075A

1. Remove the snap ring on the brake side of the driveshaft; then remove the retaining plate seal.



YM-074A

2. For installing purposes, scribe a line on the driveshaft (A) next to the drive sprocket for proper alignment; then scribe a line on the driveshaft directly in line with the timing arrows (B located on the inside of the sprockets) on the drive sprockets for proper sprocket timing.

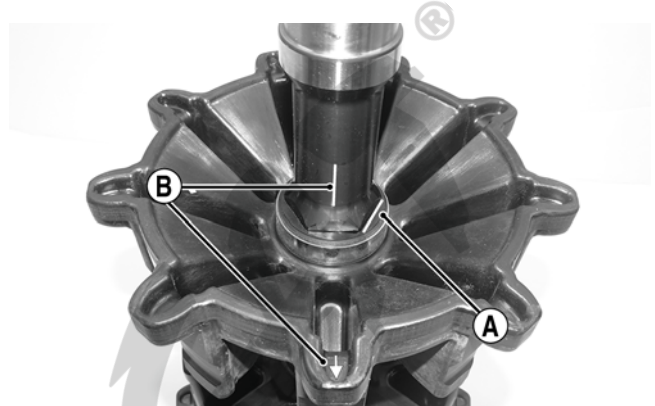

YM-071A

3. Using a suitable press positioned against the tension-collar of the drive sprocket (located on the gear case) and of the driveshaft, press the drive sprockets off the driveshaft.

CAUTION

Always press against the tension-collar of the drive sprockets or damage to the components will occur.

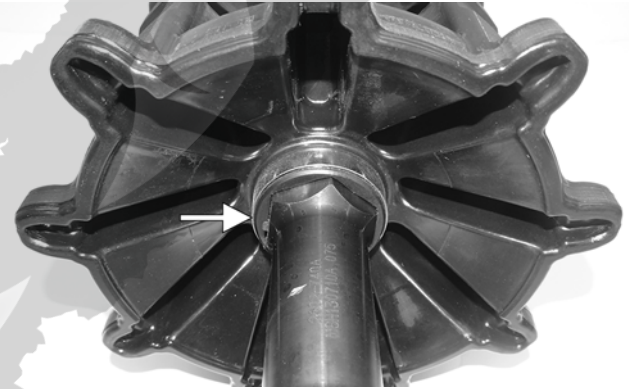

YM-069A

CLEANING AND INSPECTING

1. Thoroughly wash all metallic components in parts-cleaning solvent. Dry using compressed air.
2. Wash all non-metallic components with soap and water.
3. Inspect the driveshaft for damaged splines or stripped threads.
4. Inspect the seals for any breaks or damage.
5. Inspect the track for cuts, gouges, or wear.
6. Inspect the brake disc for wear or cracks.
7. Inspect the track drive sprockets for wear or damage.

INSTALLING

■NOTE: The drive sprockets must be installed from the brake side.

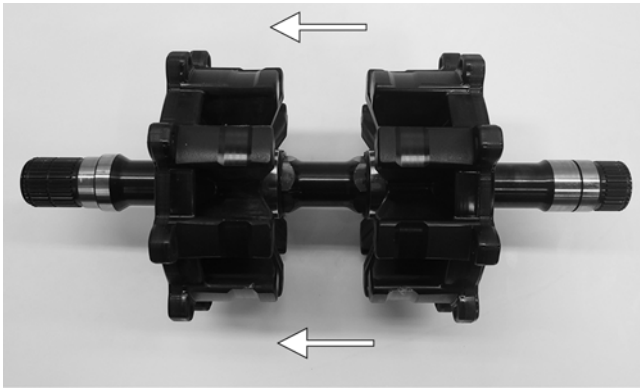

YM-075B

■NOTE: Prior to installing the sprockets onto the driveshaft, lightly chamfer the inside edge of the sprocket to avoid binding.

1. Properly align the scribed line (B) on the driveshaft (from removing) with the timing arrow on the drive sprocket; then slide the sprocket onto the driveshaft as far as it will go.

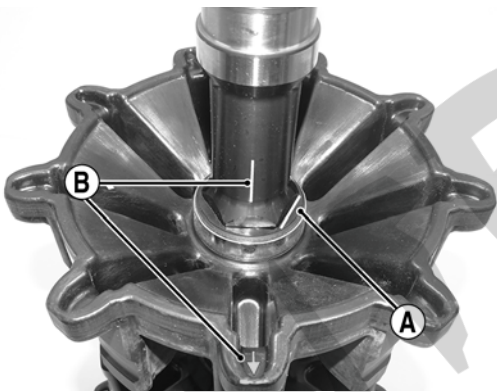

YM-071A

2. Using a suitable press and fixture, press the driveshaft into the sprocket until it aligns with the line scribed in removing.
3. Slide the remaining sprocket onto the driveshaft making sure the timing arrow/lines (from removing) are aligned; then using the press/fixture, press the sprocket to the remaining alignment line.

CAUTION

Always press against the tension-collar of the drive sprockets or damage to the components will occur.

■NOTE: When pressing new sprockets on the driveshaft, align the sprocket alignment marks or the sprockets won't be timed correctly.

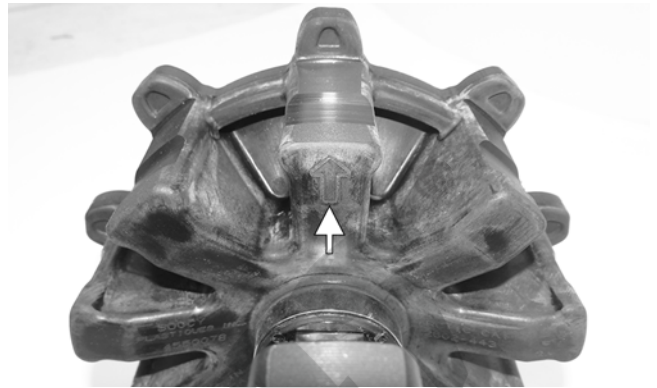

YM-072A

4. Using a calipers, measure distances between the sprockets and from the sprockets to each end of the driveshaft for proper location (see appropriate illustration).

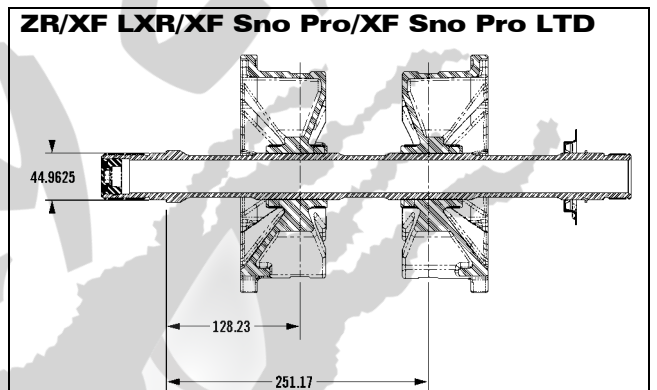

0747-963

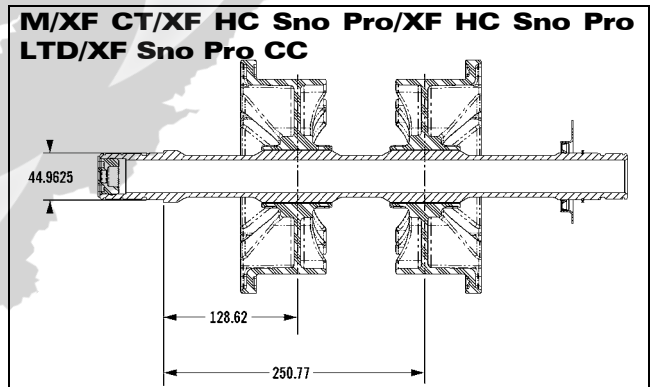

0747-960

5. Install the seal retaining plate; then install the existing snap ring.

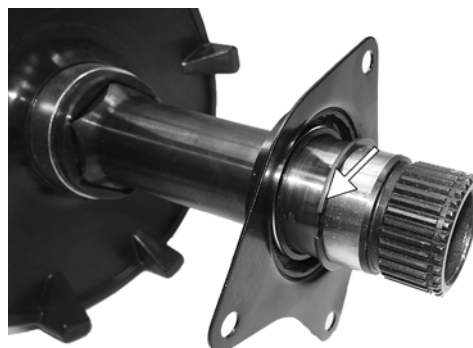

XM283A

Track Tension

CHECKING

WARNING

DO NOT attempt to check or adjust track tension with engine running. Turn ignition key to the OFF position. Personal injury could result from contact with a rotating track.

1. Remove excess ice and snow buildup from the track, track drive sprockets, and the inside of the skid frame.
2. Elevate the snowmobile on a shielded safety stand high enough to use a spring scale.
3. At mid-point of the track (on the bottom side), hook a spring scale around a track clip; then pull down on the scale to the recommended pressure. Measure the deflection (distance) between the bottom of the wear strip and the inside surface of the track clip. Compare the measurement with the chart in the General Information section.

■NOTE: Measurement is from the bottom of the wear strip at the point of the shock pad on the slide rail.

ADJUSTING

■NOTE: To ensure proper track tension adjustment, perform all adjustments on both sides of the snowmobile.

1. Loosen the idler wheel axle cap screws.

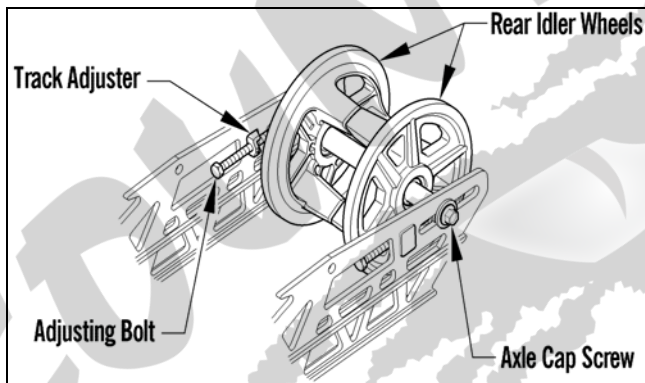

0745-811

2. If the deflection (distance between the bottom of the wear strip and the inside surface of the track clip) exceeds specifications, tighten the adjusting bolts to take up excessive slack in the track.
3. If the distance between the bottom of the wear strip and the inside surface of the track clip is less than specified, loosen the adjusting bolts to increase the slack in the track.

CAUTION

Always maintain track tension within recommended specification.

4. Check track alignment.

5. After proper track tension is obtained, tighten the idler wheel axle cap screws to 34 ft-lb.

■NOTE: Since track tension and track alignment are interrelated, always check both even if only one adjustment seems necessary.

WARNING

Always make sure the adjusting bolts are snug against the axle and the idler wheel cap screws. Failure to do so could cause the track to become extremely loose and, under some operating conditions, allow the idler wheels to climb over the track lugs forcing the track against the tunnel causing the track to “lock.” If a track “locks” during operation, severe personal injury could result.

Track Alignment

■NOTE: Proper track alignment is when the rear idler wheels are equidistant from the inner drive lugs on the inside surface of the track.

CHECKING/ADJUSTING

WARNING

Make sure the ignition key is in the OFF position and the track is not rotating before checking or adjusting track alignment. Personal injury could result if contact is made with a rotating track.

1. Remove excess ice and snow buildup from the track, track drive sprockets, and the inside of the skid frame.
2. Position the tips of the skis against a wall; then using a shielded safety stand, raise the rear of the snowmobile off the floor making sure the track is free to rotate.

WARNING

The tips of the skis must be positioned against a wall or similar object for safety. Keep hands, feet, and clothing away from moving components.

WARNING

DO NOT stand behind the snowmobile or near the rotating track. NEVER run the track at high speed when the track is suspended.

3. Start the engine and accelerate slightly. Use only enough throttle to turn the track several revolutions. SHUT ENGINE OFF.

■NOTE: Allow the track to coast to a stop. DO NOT apply the brake because it could produce an inaccurate alignment condition.

4. When the track stops rotating, check the relationship of the rear idler wheels and the inner track drive lugs. If the rear idler wheels are centered between the inner track drive lugs, no adjustment is necessary. If not, proceed to step 5.

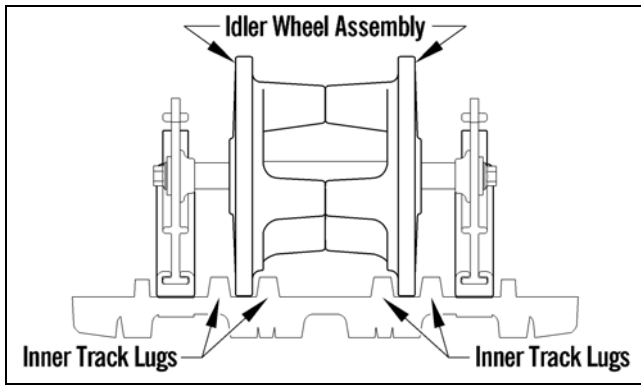

0745-809

5. On the side of the track which has the inner track drive lugs closer to the rear idler wheel, loosen the idler wheel axle cap screw; then rotate the adjusting bolt clockwise 1 to 1 1/2 turns.

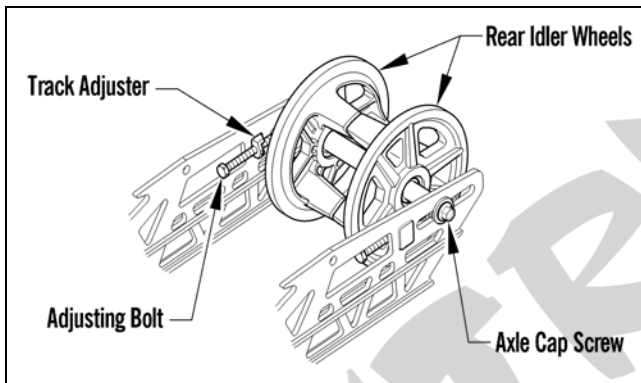

0745-811

6. Check the track alignment and make the necessary adjustments until proper alignment is obtained.

■NOTE: Make sure correct track tension is maintained after adjusting track alignment.

7. After proper track tension and alignment are obtained, tighten the idler wheel axle cap screw to 34 ft-lb; then tighten the adjusting bolt to 84 in.-lb.

⚠ WARNING

Always make sure the adjusting bolts are snug against the axle and the idler wheel cap screws. Failure to do so could cause the track to become extremely loose and, under some operating conditions, allow the idler wheels to climb over the track lugs forcing the track against the tunnel causing the track to “lock.” If a track “locks” during operation, severe personal injury could result.

■NOTE: Field test the track under actual conditions and after the field test, check track alignment and track tension; adjust as necessary.

Brake System

CHECKING BRAKE LEVER TRAVEL

1. Compress the brake lever fully.

■NOTE: Do not pump the brake lever as it will produce an inaccurate reading.

2. Measure the distance between the brake lever and the handlebar. The distance must be greater than 1 in.

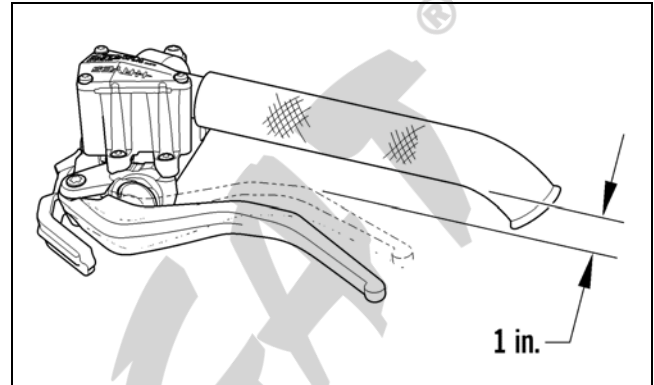

0745-816

3. If the distance is less than specified, check the brake fluid level, inspect for leakage, and check the brake pads.

⚠ WARNING

Do not operate the snowmobile if the distance between the compressed brake lever and handlebar is less than 1 in. Brake loss may occur. Brake loss can result in severe personal injury.

CHECKING AND ADDING BRAKE FLUID

1. With brake fluid reservoir in a level position and the cover removed, check the fluid level. The brake fluid level must be at the high mark in the reservoir.

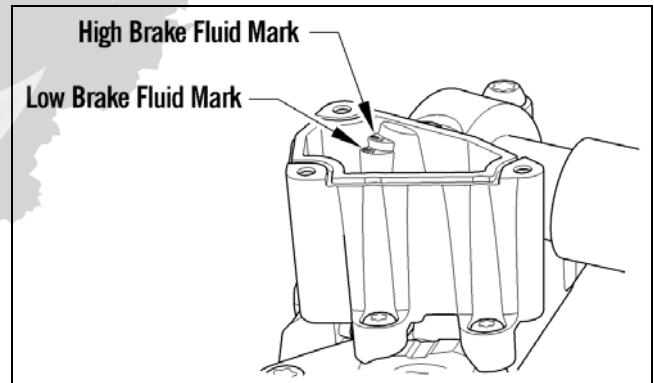

0745-817

2. If the brake fluid level is low, add Arctic Cat approved brake fluid until the fluid is at the recommended level. Install and secure the reservoir cover. DO NOT allow moisture to contaminate the brake system.

CAUTION

Brake fluid is highly corrosive. Do not spill brake fluid on any surface of the snowmobile.

⚠ WARNING

Do not overfill the brake fluid reservoir. Overfilling the reservoir may cause the brake system to hydraulically lock. Use only approved brake fluid. Never substitute or mix different types or grades of brake fluid. Brake loss may occur. Brake loss can result in severe injury or even death.

CHANGING BRAKE FLUID

The brake fluid must be changed on a regular basis and/or whenever the brake fluid has been overheated or contaminated. The brake fluid should be changed every 1000 miles or at the end of the snowmobiling season, whichever occurs first.

Arctic Cat recommends the removal and disassembly of the brake caliper assembly when changing the brake fluid.

CAUTION

Brake fluid is highly corrosive. Do not spill brake fluid on any surface of the snowmobile.

⚠ WARNING

Use only DOT 4 or DOT 5 brake fluid. Any substitute may result in a loss of brakes.

1. Slide a piece of flexible tubing over the ball of the bleeder valve and direct the other end into a container.

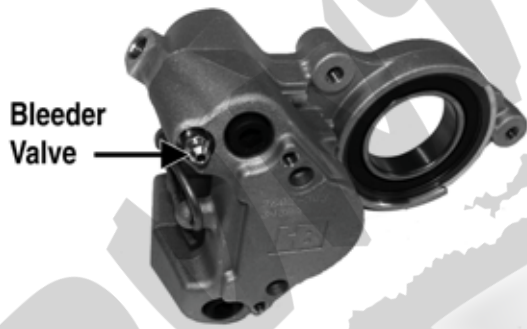

PC223A

2. Slowly compress the brake lever and hold. Open the bleeder valve to release the fluid; then compress the brake lever repeatedly until all brake fluid is expelled. Close the bleeder valve.
3. Add new approved brake fluid to the reservoir; then compress the brake lever and hold. Open the bleeder valve. Repeat the compression until brake fluid flows free of air bubbles and appears clean.

■NOTE: It may be necessary to refill the reservoir a number of times to eliminate all air bubbles in the system.

4. When the brake fluid is free of all air and the brake lever feels firm when compressed, fill the reservoir; then install and secure the cover. Remove the tube from the bleeder valve.
5. Bleed the brake system (see Bleeding Brake System in this sub-section).

BLEEDING BRAKE SYSTEM

If the brake lever feels spongy when applied, the brake system may need to be bled.

1. With the handlebar in the highest position, remove the reservoir cover and fill the reservoir with approved brake fluid.

CAUTION

Brake fluid is highly corrosive. Do not spill brake fluid on any surface of the snowmobile.

⚠ WARNING

Use only approved brake fluid. Any substitute may result in a loss of brakes.

⚠ WARNING

Do not use brake fluid from a container opened for a long period of time. Unsealed brake fluid containers will absorb moisture and can contaminate the fluid inside.

2. Slide a piece of flexible tubing over the ball of the bleeder valve and direct the other end into a container.

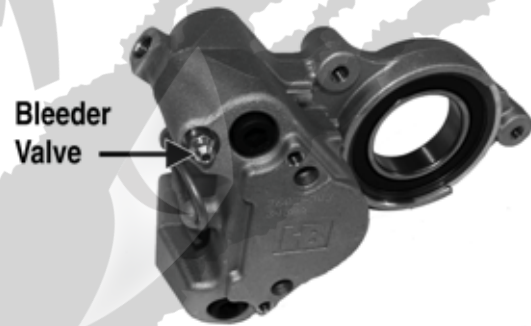

PC223A

3. Slowly compress the brake lever and hold. Open the bleeder valve to release the fluid and air. When the fluid stops flowing, close the bleeder valve; then release the brake lever.
4. Repeat step 3 until the brake fluid flows free of air bubbles.

■NOTE: It may be necessary to refill the reservoir during the bleeding process.

5. When the brake fluid is free of all air and the brake lever feels firm when compressed, fill the reservoir; then install and secure the cover. Remove the tube from the bleeder valve.

CHECKING AND REPLACING BRAKE PADS

1. Remove the brake shield; then remove the retaining pin securing the brake pads.

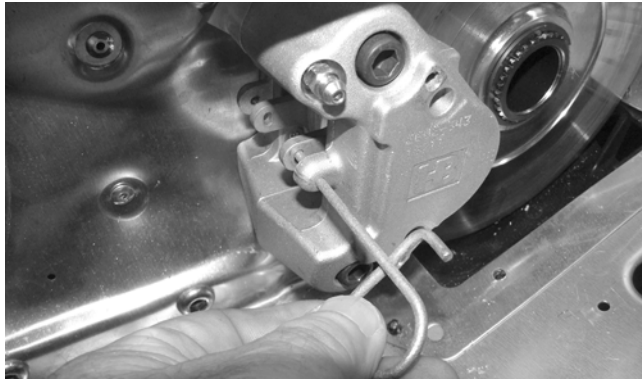

PC195

2. Remove one brake pad and measure the thickness.

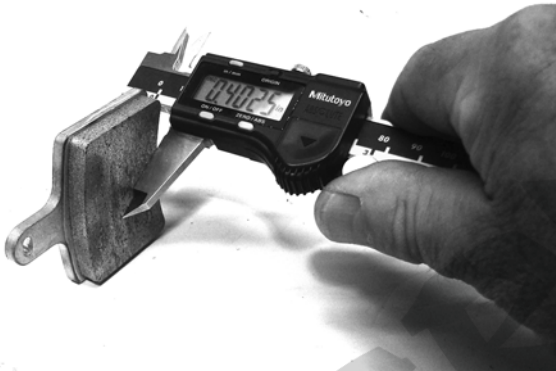

PC199

■NOTE: Brake pad thickness must be greater than 0.20 in. If brake pad thickness is less than specified, replacement of both pads is necessary. Always replace with new pads and always replace as a set.

3. Position the new brake pad into the caliper.
4. Repeat for the other pad; then secure the pads with the retaining pin.

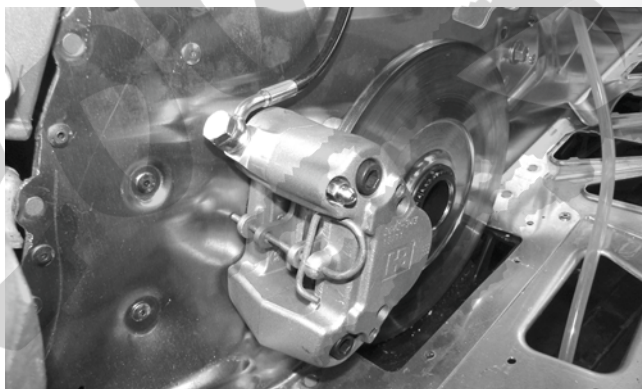

PC194

■NOTE: When new brake pads are installed, a “burnishing” process is required. Drive the snowmobile slowly and compress the brake lever several times until the pads just start to warm up; then allow them to cool down. This procedure stabilizes the pad material and extends the life of the pads.

BRAKE CALIPER/BRAKE DISC/ DRIVESHAFT BEARING

Removing/Disassembling

1. Remove both access panels; then remove the drive belt and driven clutch.
2. Remove the screws securing the brake shield and foot-rest to the chassis.
3. Slide a piece of flexible tubing over the ball of the bleeder valve and direct the other end into a container.

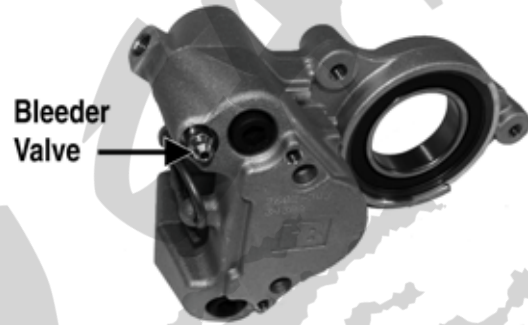

PC223A

CAUTION

Brake fluid is highly corrosive. Do not spill brake fluid on any surface of the snowmobile.

4. Open the bleeder valve and compress the brake lever several times to drain the reservoir of fluid.
5. Remove the brake hose from the caliper. Use an absorbent towel to collect any remaining brake fluid.
6. Remove the retaining pin securing the brake pads; then remove both pads.

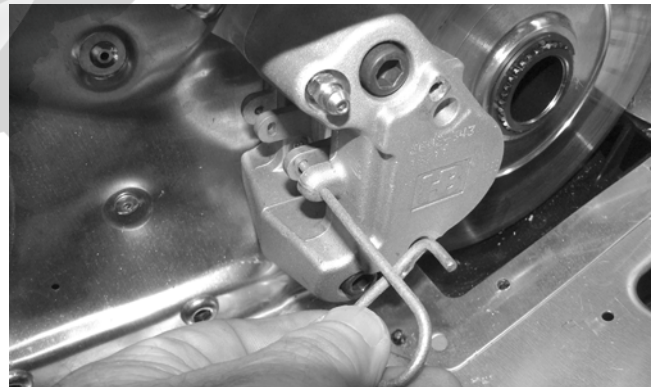

PC195

■NOTE: If servicing the brake disc only, remove the cap screws securing the caliper housings together; then remove the outside housing. Account for the seal.

CAUTION

If the caliper housings are to be separated, take care not to allow any contaminants into the fluid passages of the calipers.

■NOTE: To aid in removing the inner caliper housing, completely loosen track tension.

7. Remove the retaining ring from the driveshaft and remove the brake disc; then remove the cap screws securing the inner caliper/driveshaft bearing housing to the chassis.

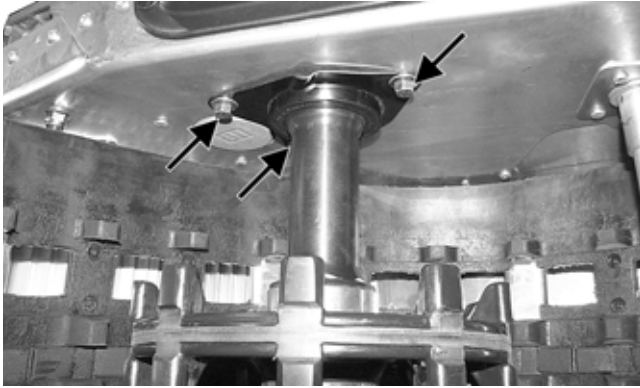

PC148A

8. If the bearing will be replaced, remove the retaining ring; then using a suitable press, remove the bearing from the housing.

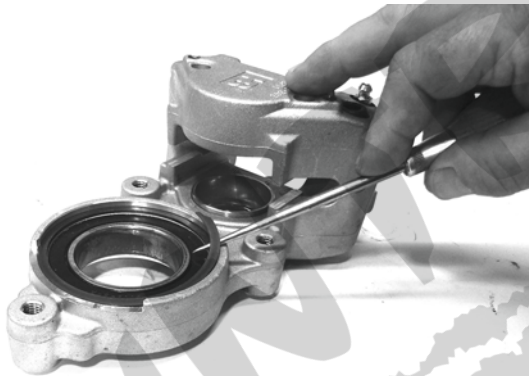

PC200

■NOTE: Never reuse bearings that have been removed. Always use new bearings.

■NOTE: If the caliper housings were separated, they must be secured together with the seal installed between the inner and outer housings.

9. Position a piece of wood between the pistons. Using low-pressure compressed air, blow into the caliper brake hose fitting to loosen the brake pistons.

⚠ WARNING

Always wear safety glasses when using compressed air.

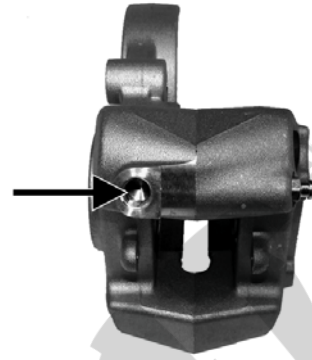

PC221A

10. Remove the two screws securing the caliper halves. Discard the seal.



PC219A

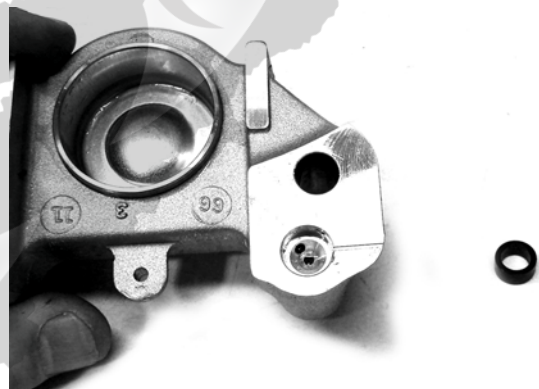

PC173

11. Remove the pistons (A) and O-rings (B); then discard the O-rings.

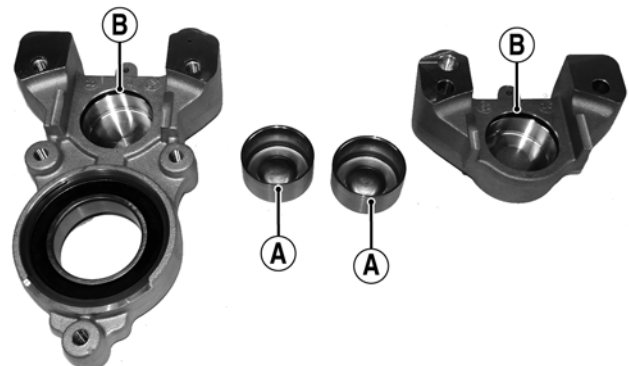

PC220A

Cleaning and Inspecting

1. Inspect the brake pistons for gouges, cracks, pitting, scuffing, or corrosion. If any of these conditions exist, replace the piston.

■NOTE: The inner and outer caliper housings are not serviceable components. If either or both are defective or damaged, the complete caliper assembly must be replaced.

2. Clean the piston outer surface by using a soft Scotch-Brite pad and clean brake fluid as a cleaner.

CAUTION

Do not use any sharp cleaning tool on the piston surface or in the O-ring groove as it may cause damage.

3. Inspect the piston bore of the inner and outer brake calipers for gouges, cracks, pitting, scuffing, or corrosion. If any of these conditions exist, replace the caliper.
4. Clean the caliper inner wall surface using a soft lint-free cloth and clean brake fluid.

CAUTION

Care must be taken not to allow any contaminants into the fluid passages of the calipers or brake system malfunction may occur.

5. Inspect the condition of the brake pads. Replace if damaged or worn. The brake pad thickness must be greater than 0.20 in. If the brake pad thickness is less than specified, replacement of both pads is necessary.
6. Inspect the brake hose for cracks and deterioration and check the condition of the threaded connectors.

Assembling/Installing

1. Apply approved brake fluid to new O-rings; then install the O-rings into the groove of each caliper half.

CAUTION

Never reuse piston O-rings. Always install new O-rings when installing pistons in the brake caliper.

2. In each caliper half, apply approved brake fluid to the brake piston; then while twisting, install the piston with the dished side facing out.



PC201

■NOTE: To aid in installing the piston, make sure the piston O-ring is properly seated in the groove of the caliper housing.

3. Using a suitable press, install a new inner bearing into the caliper housing until it is properly seated.

CAUTION

When installing a bearing, always press on the outer race of the bearing.



ZJ239A

4. Install the snap ring securing the bearing in the caliper housing.

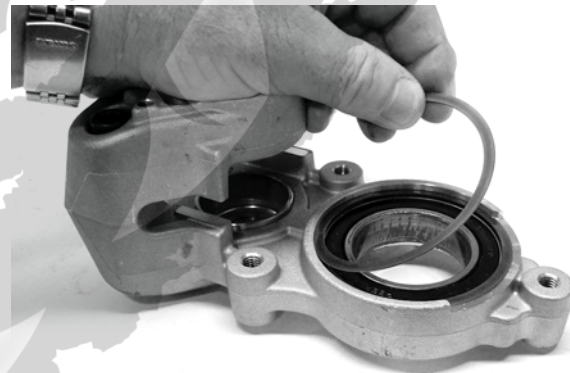

PC204

5. Place the inner caliper housing/driveshaft bearing housing onto the driveshaft and secure with the cap screws coated with blue Loctite #243. Tighten to 25 ft-lb.
6. Apply Anti-Seize Thread Compound to the splines of the brake disc; then install on the driveshaft and secure with the retaining ring.
7. Install a new seal in the outer caliper fluid passage; then install the outer caliper and secure with the cap screws. Tighten to 25 ft-lb.

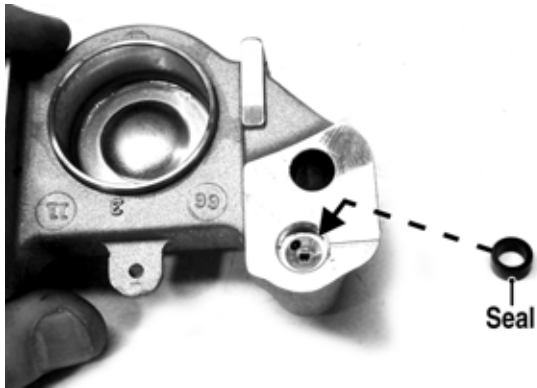

PC173A

8. Install new brake pads in the caliper and secure with the retainer pin.

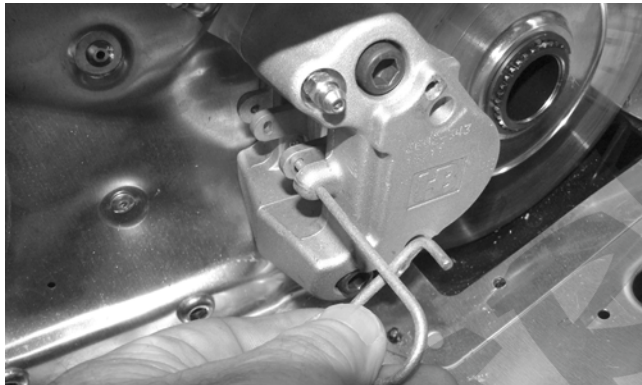

PC195

9. Bleed the brake system (see Bleeding Brake System in this sub-section).
10. Install the brake shield and footrest; then install the drive belt (see Drive Belt in this section) and driven clutch. Tighten the driven clutch cap screw to 20 ft-lb.
11. Adjust the track tension (see Track Tension in this section) and track alignment (see Track Alignment in this section).
12. Close and secure both side panels.

Brake Lever/Master Cylinder Assembly

REMOVING

1. Slide a piece of flexible tubing over the ball of the bleeder valve and direct the other end into a container.

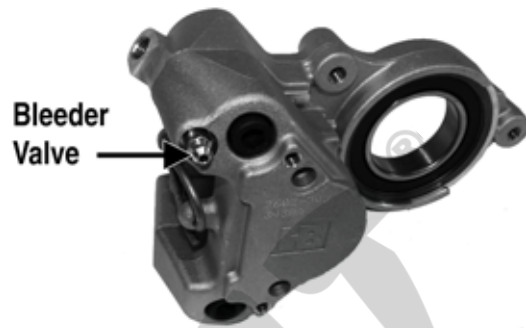

PC223A

2. Remove the two screws securing the reservoir cover and remove the reservoir cover; then open the bleeder valve. Allow the brake fluid to drain completely.
3. Place an absorbent towel around the connection to absorb brake fluid. Remove the banjo-fitting bolt (A) securing the brake fluid hose (B) to the master cylinder. Discard the two crush washers.

CAUTION

Brake fluid is highly corrosive. Do not spill brake fluid on any surface of the snowmobile.

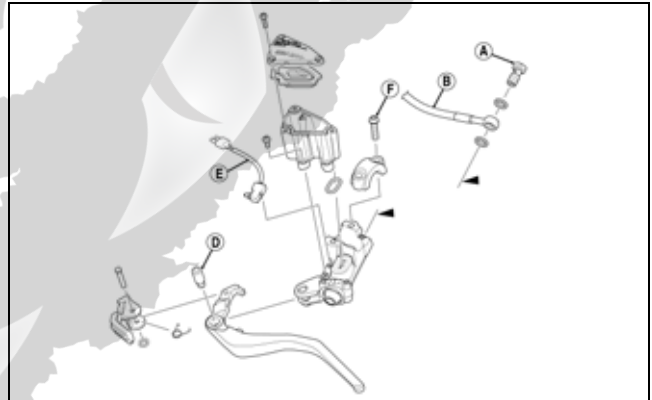

745-759A

4. Remove the pin (D) securing the brake lever to the master cylinder.
5. Using a small screwdriver, compress the tabs of the brake-light switch (E) to release it from the master cylinder.
6. Remove the two torx-head screws (F) and clamp securing the brake reservoir to the handlebar; then place a towel over the reservoir and remove the assembly from the handlebar.

INSPECTING

1. Inspect the snap ring and pin securing the brake lever for wear or damage; then inspect the brake lever for cracks or damage.
2. Inspect the master cylinder reservoir and cover for cracks and leakage.

■NOTE: The master cylinder is a non-serviceable component. If any wear or damage is detected, the master cylinder must be replaced.

3. Inspect the brake fluid hose for cracks, deterioration, and the condition of the fittings (threaded and compression).

INSTALLING

1. Position the brake assembly on the handlebar. Secure with two torx-head screws (F) and clamp; tighten securely.
2. Install the brake fluid hose (B) to the master cylinder with the banjo-fitting bolt (A) and two new crush washers. Tighten securely.

CAUTION

Always use new crush washers when installing the brake fluid hose.

3. Install the brakelight switch (E) to the master cylinder.
4. Install the brake lever; then secure with pin (D).
5. Place the reservoir cover onto the reservoir; then secure with the two screws.
6. Bleed the brake system (see Bleeding Brake System in this sub-section).

Troubleshooting Hydraulic Brake System

Problem: Caliper Leaks	
Condition	Remedy
1. Caliper O-ring deteriorated — severed 2. Piston — O-ring damaged	1. Replace O-ring 2. Repair piston — replace piston — O-ring
Problem: Lever Spongy — Bottoms Out	
Condition	Remedy
1. Brake system air bubbles present 2. Master cylinder damaged — faulty	1. Bleed brake system 2. Replace master cylinder
Problem: Oscillation Feedback in Lever	
Condition	Remedy
1. Brake pad residue present on brake disc 2. Caliper loose	1. Replace pads — clean disc 2. Tighten mounting bolts
Problem: Loss of Brake	
Condition	Remedy
1. Brake fluid overheated — contaminated 2. Master cylinder damaged — faulty 3. Caliper — brake hose leaking 4. Brake lever linkage damaged	1. Replace fluid 2. Replace master cylinder 3. Replace caliper O-ring — repair piston — replace piston — O-ring — brake hose 4. Repair — replace lever — mounting bolt
Problem: Brakes Drag	
Condition	Remedy
1. Master cylinder damaged — faulty 2. Brake pads worn — tapered	1. Replace master cylinder 2. Replace pads
Problem: Snowmobile Won't Stop — Have to Pull Too Hard on Lever	
Condition	Remedy
1. Pads/brake disc glazed 2. Brake lever binding 3. Caliper pistons binding	1. Replace pads — clean disc 2. Loosen pivot bolt — replace master cylinder 3. Service caliper assembly

Troubleshooting Track

Problem: Track Edge Frayed — Drive Lugs Worn	
Condition	Remedy
1. Track alignment adjusted incorrectly	1. Align — replace track
Problem: Track Worn Adjacent to Outer Drive Lugs	
Condition	Remedy
1. Track tension adjusted incorrectly	1. Adjust track tension
2. Rear idler wheels dirty — damaged	2. Clean — replace idler wheels
Problem: Track Ratchets — Slaps Tunnel	
Condition	Remedy
1. Track tension adjusted incorrectly (too loose)	1. Adjust track tension (tighten)
2. Drive sprockets misaligned — damaged	2. Align — replace sprockets
Problem: Wear-Strip Wear Excessive	
Condition	Remedy
1. Slide rail bent — broken — damaged	1. Repair — replace slide rail
2. Track alignment adjusted incorrectly	2. Adjust track alignment

Troubleshooting Drive Clutch/Driven Clutch

Problem: Midrange Shift-Up (Too Quickly - Lowers RPM)	
Condition	Remedy
<ol style="list-style-type: none"> 1. Drive clutch spring weak 2. Driven clutch spring weak 3. Driven clutch spring preload tension inadequate 4. Center-to-center distance too close 5. Driven clutch bearing worn — damaged 	<ol style="list-style-type: none"> 1. Replace drive clutch spring 2. Replace driven clutch spring 3. Replace driven clutch spring 4. Adjust center-to-center distance 5. Replace bearing — movable sheave
Problem: Midrange Shift-Up (Too Slowly - Raises RPM)	
Condition	Remedy
<ol style="list-style-type: none"> 1. Drive clutch components dirty 2. Driven clutch components dirty 3. Driven clutch spring preload tension excessive 4. Driven clutch bearing worn — dirty 	<ol style="list-style-type: none"> 1. Clean drive clutch components 2. Clean driven clutch components 3. Replace driven clutch spring 4. Clean — replace bearing — movable sheave
Problem: Excessive Belt Deposits	
Condition	Remedy
<ol style="list-style-type: none"> 1. Offset/parallelism incorrect 2. Drive clutch/driven clutch sheaves rough — damaged — dirty 3. Driven clutch movable sheave travel impaired 4. Driven clutch bearing worn — dirty 	<ol style="list-style-type: none"> 1. Adjust offset/parallelism 2. Repair — replace — clean drive clutch/driven clutch 3. Service driven clutch 4. Clean — replace bearing — movable sheave
Problem: Excessive Belt Drag—Impaired Drive Clutch Disengagement	
Condition	Remedy
<ol style="list-style-type: none"> 1. Drive clutch components dirty — damaged 2. Drive belt does not meet measurement specifications 	<ol style="list-style-type: none"> 1. Clean — replace drive clutch components 2. Replace drive belt
Problem: Engine RPM Suddenly Increases—Drive Clutch Vibrates	
Condition	Remedy
<ol style="list-style-type: none"> 1. Cam arm pin bent — damaged 2. Cam arm damaged — broken 3. Drive clutch out of balance 	<ol style="list-style-type: none"> 1. Replace pin 2. Replace cam arm 3. Align — replace components — drive clutch — drive belt
Problem: Driven Clutch Vibrates	
Condition	Remedy
<ol style="list-style-type: none"> 1. Driven clutch out of balance 	<ol style="list-style-type: none"> 1. Service — replace driven clutch
Problem: Drive Clutch Engagement (Before Specified RPM)	
Condition	Remedy
<ol style="list-style-type: none"> 1. Drive clutch spring weak — bent 2. Cam arms incorrect — worn 	<ol style="list-style-type: none"> 1. Replace spring 2. Replace cam arms
Problem: Drive Clutch Engagement (After Specified RPM)	
Condition	Remedy
<ol style="list-style-type: none"> 1. Drive clutch spring incorrect 2. Spider buttons worn 	<ol style="list-style-type: none"> 1. Replace spring 2. Replace clutch
Problem: Drive Clutch Sticks	
Condition	Remedy
<ol style="list-style-type: none"> 1. Drive clutch components dirty 2. Movable sheave bent — binding 3. Spider buttons worn 	<ol style="list-style-type: none"> 1. Clean drive clutch components 2. Clean — replace movable sheave 3. Replace clutch
Problem: Drive Clutch Jerks—Shifts Erratically	
Condition	Remedy
<ol style="list-style-type: none"> 1. Drive clutch dirty 2. Rollers worn 3. Cam arms rough 4. Spider buttons worn 5. Sheaves dirty 	<ol style="list-style-type: none"> 1. Clean — drive clutch components 2. Replace clutch 3. Polish — replace cam arms 4. Replace clutch 5. Clean sheaves

Suspension

■NOTE: Whenever a part is worn excessively, cracked, or damaged in any way, replacement is necessary.

SPECIAL TOOLS

A number of special tools must be available to the technician when servicing the rear suspension.

Description	p/n
Shock Absorber Air Pump	2603-614
Idler Wheel Puller Kit	0644-570
Rear Suspension Spring Tool	0144-311
Handlebar Stand	5639-152
Steering Post Stand	5639-946

■NOTE: Special tools are available from the Arctic Cat Service Parts Department.

UNDERSTANDING THE SUSPENSION

Quick acceleration and the ability to go through the turns with power are the most important handling qualities. This section explains how the skid frame functions to provide these two important handling qualities. Before proceeding, however, note these terms.

Weight Transfer — A shift in the center of gravity in any direction depends on the force applied.

Track Tension — The amount of tightness or looseness of the track when correctly mounted in the chassis.

Spring Tension — The amount of force exerted on the spring by either fork tension adjustment or eyebolt adjustment.

Ski Pressure — The amount of force exerted downward on the skis.

Good weight transfer characteristics are needed for fast acceleration (shift of weight from skis to track) and for cornering (shift of weight back to skis to hold the front end in turns). Effective weight transfer depends on suspension tension, position of rider, and the position of the front arm limiter.

To understand how the suspension system works, think of the entire system in terms of three points; the skid frame rear axle center, the skid frame front arm, and the ski saddle center.

Assume that the front arm functions as a stationary pivot point between the rear axle center and the ski saddle center. Also assume that the ski saddle center is the same height off the ground as the rear axle center. This produces the standard position arrangement.

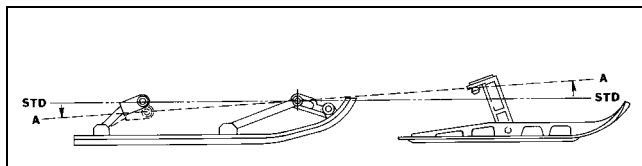

0728-180

Under acceleration when the center of gravity is transferred to the rear of the machine, the rear suspension collapses slightly. This brings the rear arm point downward and with the front arm stationary, the teeter-totter effect reduces the pressure on the skis, position A.

However, for controlled cornering, more pressure is needed on the skis. So when the driver decelerates coming into a corner, the center of gravity is transferred forward, putting the required pressure onto the skis and reducing the pressure on the rear suspension, position C.

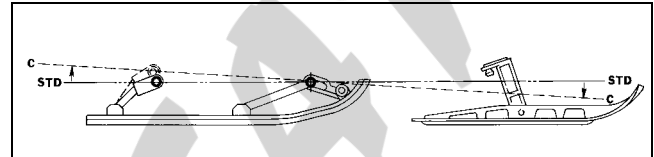

0728-181

This is essentially what weight transfer is all about — the shift of weight to the rear of the machine for positive traction and good acceleration or to the front of the machine for positive handling and cornering control.

Suspension Setup Basics

SKI SHOCK ABSORBER SPRINGS

The shock absorber springs have been matched to the shock valving and rear suspension. These springs are the result of hours of testing and comparison riding trying many different combinations of springs and shocks. If changes are necessary, several spring and shock sizes are available. While making these changes, keep the following points in mind.

Heavier Or Stiffer Springs

1. These will require shocks with more rebound control, or the front end will become like a pogo stick.
2. With stiffer springs, the front end will become more aggressive in the corners as more weight will be transferred to the skis when decelerating. Also, more weight is transferred to the rear on acceleration and can cause the rear shocks and spring to bottom out.
3. If the springs are too stiff for general riding conditions and style, the ride comfort is gone.

Spring Tension Too Soft

1. Front end bottoms out; hard on front end parts.
2. Less aggressive steering in corners on deceleration, and less weight is transferred to the skis because of softer springs.
3. Less weight gets transferred to rear of the machine upon acceleration.

■NOTE: When softening the ski springs, also soften the rear to match entire suspension.

CAUTION

If the ski shock spring is adjusted too loose, the spring retainer may fall out. If the spring is adjusted beyond specification, the spring will coil bind and spring adjuster damage will occur.

ADJUSTING SKI SHOCKS (Fox Float Shocks)

The float shocks are individually adjustable for the terrain conditions and driving style of the operator. The ski shocks are initially preset at the factory (see the General Information section). However, the shocks can be “fine tuned” to match the operator’s weight, riding style, and terrain conditions.

■NOTE: Care should be taken to have equal pressure in the shocks before operating the snowmobile.

To increase or decrease air pressure, use the following procedure.

■NOTE: The shocks should not be under load when adjusting.

■NOTE: Adding air pressure will increase the air spring force; reducing air pressure will decrease air spring force.

⚠ WARNING

Do not exceed 10.5 kg/cm² (150 psi) in the shock and 21 kg/cm² (300 psi) in the evol (if equipped).

1. Remove the air valve cap from the shock; then thread the valve of Shock Absorber Air Pump onto the shock air valve approximately six rotations.

■NOTE: As the pump is being attached to the shock, the hose will fill with air resulting in a lower gauge pressure 0.14-3.52 kg/cm² (2-5 psi).

2. To decrease air pressure in the shock, press the black bleed valve button half way down and hold until desired pressure is attained.

■NOTE: Pressing the button fully down and releasing it will allow only a small amount of air to escape (micro-adjust).

3. To increase air pressure in the shock, pump until desired pressure is attained.
4. Remove the pump valve from the shock air valve.

■NOTE: As the pump valve is being removed from the shock, the sound of air loss is from the pump hose, not from the shock.

5. Install the air valve cap onto the shock.

FRONT ARM SPRING TENSION

Having very light front arm spring tension is desirable. When riding in 4 in. or more of snow, the machine will be quicker if the front spring tension is adjusted lightly.

If the spring tension is adjusted too stiff, the track angle at the front of the skid frame is steep. This steep angle prevents the snowmobile from getting up on plane and slows down by 5 to 8 mph. Also, the following could occur.

1. Slows machine down in loose snow.
2. Causes the snowmobile to dart and dive as a result of less track on the ground on deceleration.

■NOTE: A tight front arm works well under only two conditions: sticky snow conditions in the spring of the year and in hill climbing on hard packed snow.

With the front arm adjusted too soft, the spring may come off the roller.

When riding in sticky snow (springtime or warm days) or hill climbing on hard snow, it may be desirable to stiffen the front arm spring tension. When this is done, weight is transferred back quicker. The problem with too much front arm spring tension is that the feel of the snowmobile becomes very short. The reason for this is the front arm becomes the pivot point between the spindles and rear of the snowmobile. With dominant spring tension on the front arm, the suspension is basically contacting the snow from a point below the front arm to the skis or the spindle pressure point. This makes for a very short and darting snowmobile on the trail. This is especially true when decelerating and the center of gravity is transferred forward.

A method for adjusting the front spring tension follows.

■NOTE: The spring tension should be set as soft as possible when operating on trails and in deep snow.

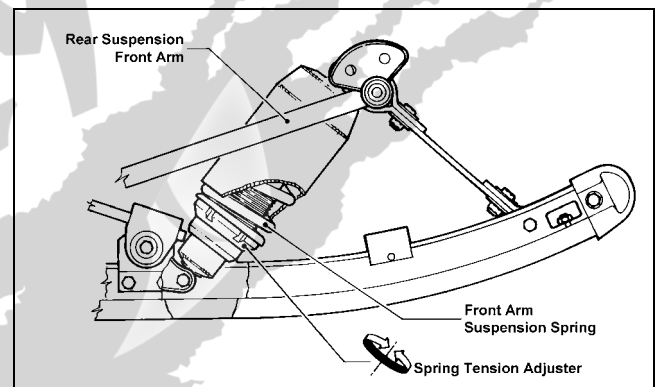

0729-662

FRONT ARM LIMITER STRAPS

Under no circumstances should the front arm limiter strap be lengthened. If lengthened, it may cause shock absorber travel problems.

The two limiter straps can be shortened to suit driving style and some test driving time. With the rear arm in its present mounting location, no advantage has been noted from changing the strap length. If the front arm straps are shortened, the result will be more ski pressure and aggressive steering.

REAR ARM SHOCK SPRING (M/XF)

Proper adjustment of rear arm shock absorber spring pre-load is necessary to get the most desirable ride.

The rear arm shock spring is adjustable for the terrain conditions and driving style and weight of the operator. The spring adjuster nut has been set at the factory so the correct amount of threads are exposed between the adjuster nut and the threaded shock body as an initial setting.

Rear spring pre-load adjustment is accomplished by loosening the adjuster nut locking collar (B) from the adjuster nut (A) and using the Spring Adjuster Tool from the tool kit, rotating the adjuster nut in whichever direction is desired. Tighten the locking collar against the adjuster nut.

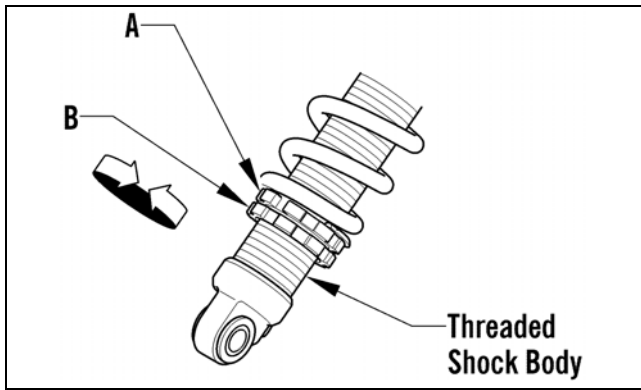

0745-159

REAR ARM SPRING TENSION (ZR)

The rear spring tension is adjusted for the weight of the driver. Three possible adjustments exist.

1st block position - set for up to 150 lb

2nd block position - set for 150 to 200 lb

3rd block position - set for over 200 lb

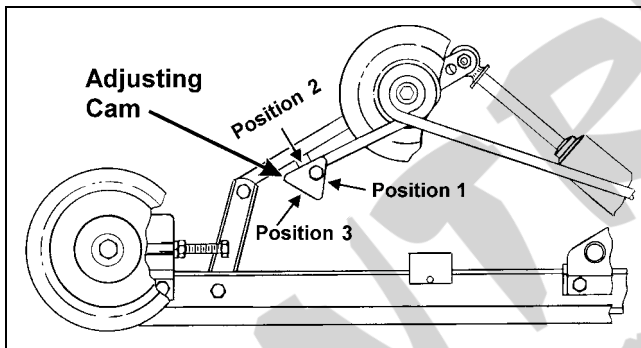

727-720A

■NOTE: When making any changes to the front or rear suspension, the change should be made at both ends to keep the suspension balanced. For example, installing stiffer springs in front may require installing the next step stiffer spring in back to keep everything in balance.

ADJUSTING REAR ARM COUPLER

The rear arm coupler provides advantages over the standard suspension.

First, with the coupler system, ski lift under acceleration is greatly reduced which provides improved handling. Second, when riding through rough terrain, the rear suspension arm receives some needed assistance from the front arm shock and spring as the rear arm is fully collapsed and locked up by the coupler blocks. The front arm then starts to collapse the shocks and spring which assist the rear springs. The result is a smoother ride for the operator.

If additional coupler action is desired, the coupler blocks can be set to the number 2 or 3 position. Each of the coupler blocks has three positions numbered on the inside surface of the block. When changing the block position, change both to the same number. To make the coupler adjustment, follow the procedure below.

1. Loosen the two cap screws that secure the coupler blocks to the inside of the suspension rails.
2. Rotate the coupler blocks to the desired position making sure both are set the same.

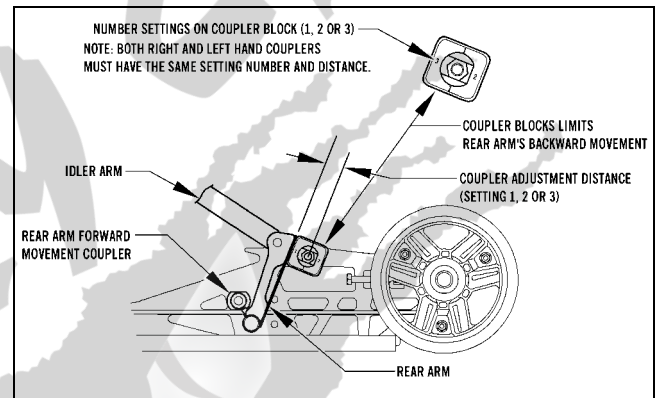

0747-212

3. Place a 4-in. block of wood under the rear of the suspension just in front of the rear idler wheels to assist in collapsing the suspension.
4. Collapse the rear suspension until the rear arm is firmly against the coupler blocks aligning the two blocks squarely with the arm. While in this position, tighten the two cap screws securely.

Chassis and Skid Frame Mounting Locations

The suspensions have several possible mounting locations in the slide rails and tunnel. However, Arctic Cat recommends that when disassembling and assembling the suspension, all stock mounting locations be used as shown in the following illustrations.

CAUTION
 All stock mounting locations must be used. If any alterations to the skid frame are made, shock absorber and suspension damage may occur.

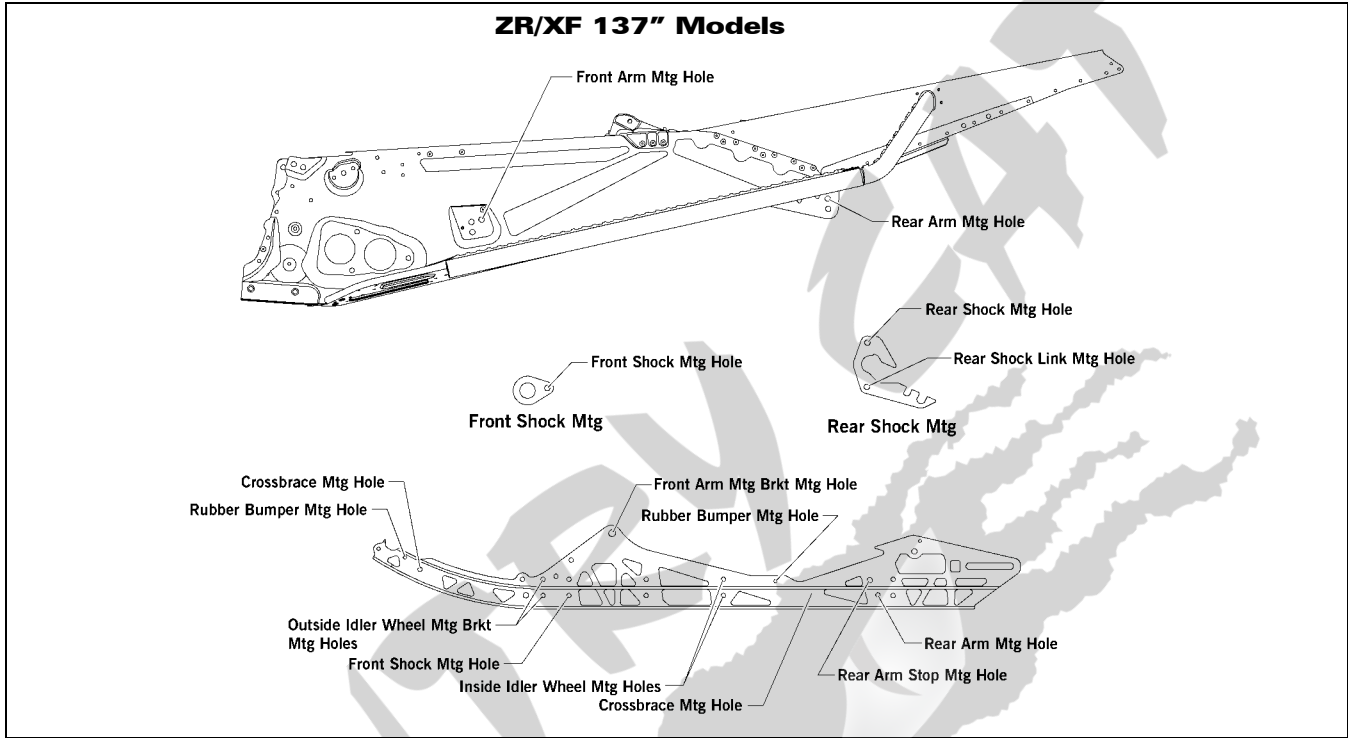

0747-413

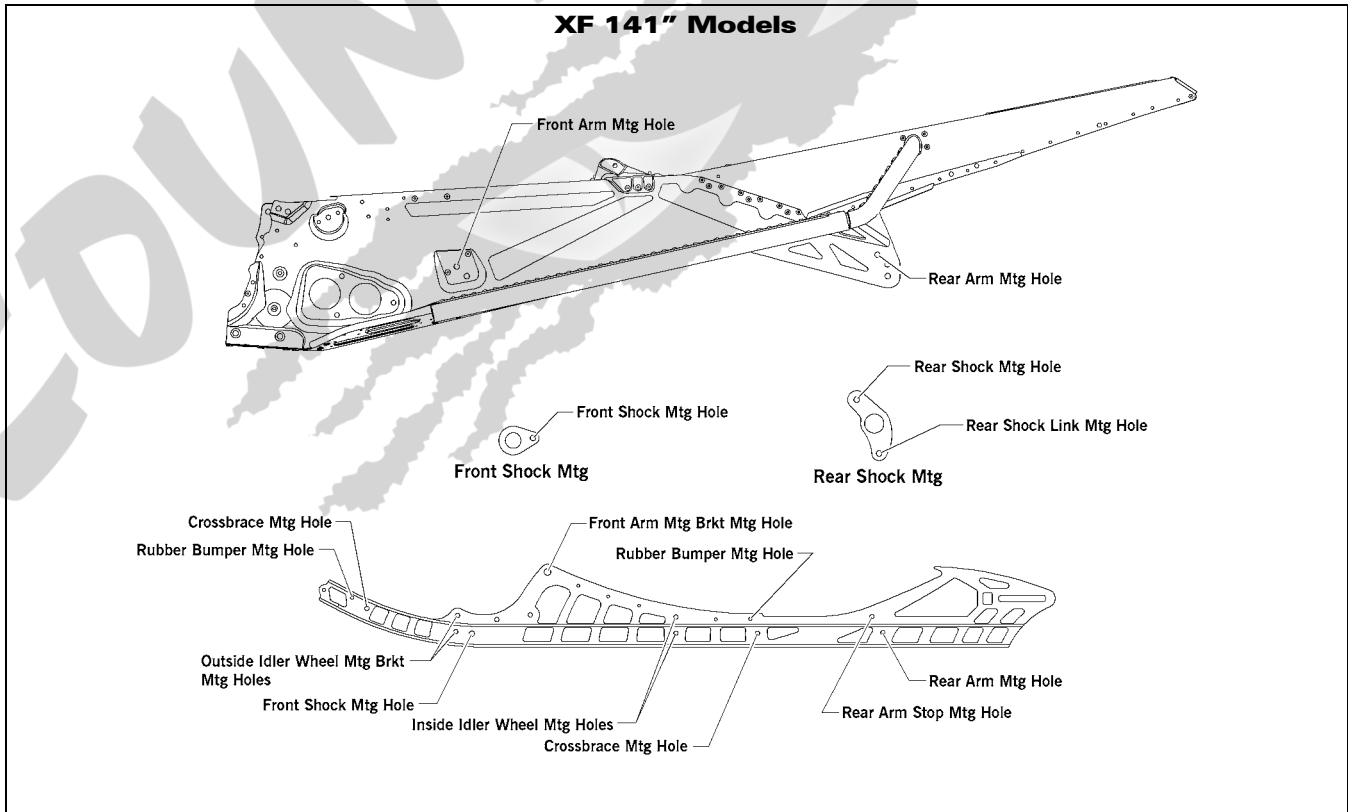

0747-988

M Models

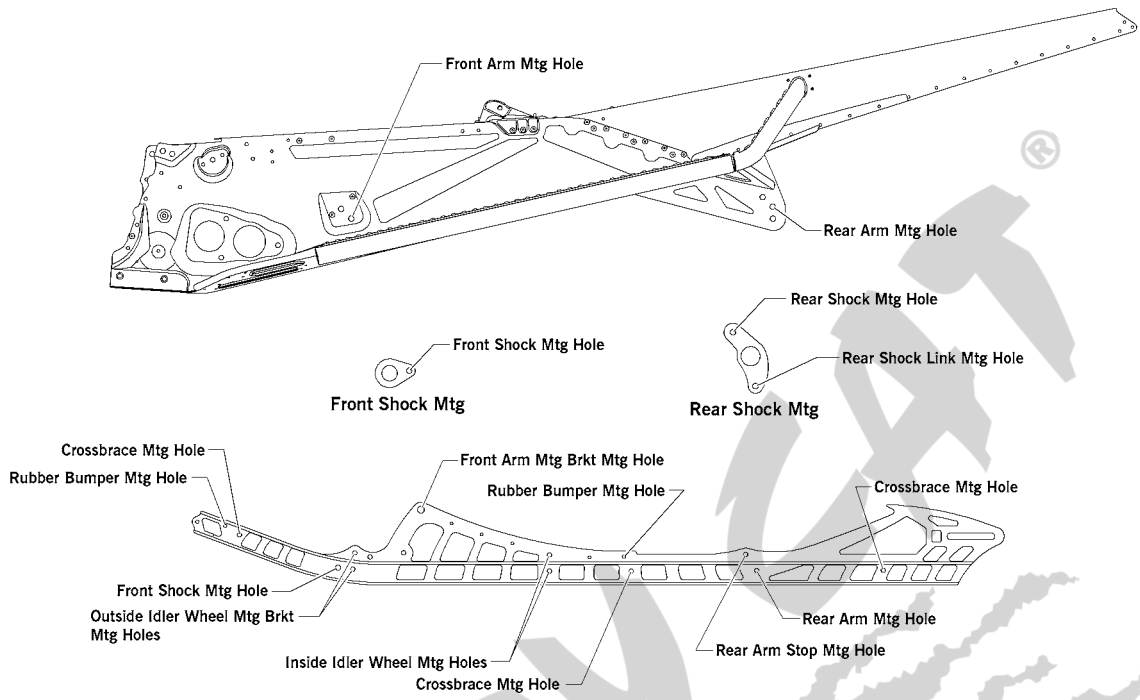

0747-414

Servicing Suspension

This sub-section has been organized so each procedure can be completed individually and efficiently.

■NOTE: Some components may vary from model to model. The technician should use discretion and sound judgment when removing and installing components.

■NOTE: Whenever a part is worn excessively, cracked, or damaged in any way, replacement is necessary.

Removing Skid Frame

■NOTE: Many service procedures can be performed without removing the skid frame. The technician should use discretion and sound judgment when removing and installing components.

1. Loosen the jam nuts and two track-tension adjusting bolts.
2. Place a support stand under the rear bumper; then while holding the flared bushing, remove the rear arm assembly cap screws securing the skid frame to the tunnel.

■NOTE: The support stand should hold the snowmobile level but not raised off the floor.

3. Remove the support stand; then using an appropriate handlebar/steering post stand, tip the snowmobile onto one side.
4. On the ZR, slide the skid frame rearward far enough to drop the front arm out of the slider axle; then remove the skid frame.
5. On the M and XF, remove the two cap screws and nuts securing the front of the skid frame to the chassis. Account for two washers.

End Caps

REMOVING

1. Remove the lock nut and cap screw securing the end cap.

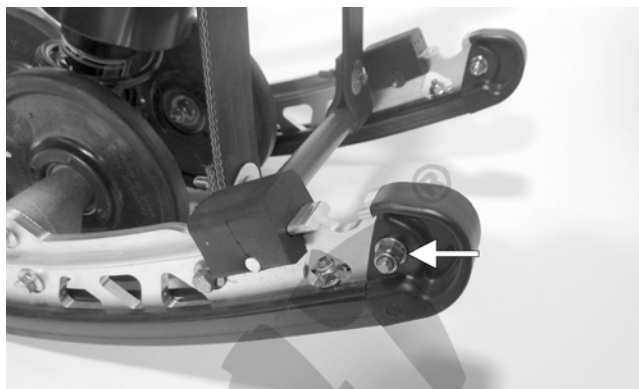

FZ096B

2. Using a hammer, tap the end cap off the rail.

CLEANING AND INSPECTING

1. Inspect the end cap area of the slide rail for cracks and wear.
2. Inspect the end cap for any signs of cracking or wear.
3. Clean both the slide rail area and the end cap. Using compressed air, clean the areas of dirt and gravel.

⚠ WARNING

Always wear an approved pair of safety glasses when using compressed air.

4. Inspect the cap screw for cracked, stretched, or damaged threads. Use a new lock nut when assembling.

INSTALLING

1. Position the end cap on the slide rail; then align the hole in the end cap with the hole in the slide rail.
2. Secure with a cap screw, washers, and lock nut. Tighten to 80 in.-lb.

Wear Strips

REMOVING

1. Remove the machine screw and lock nut securing the wear strip to the front of the slide rail.

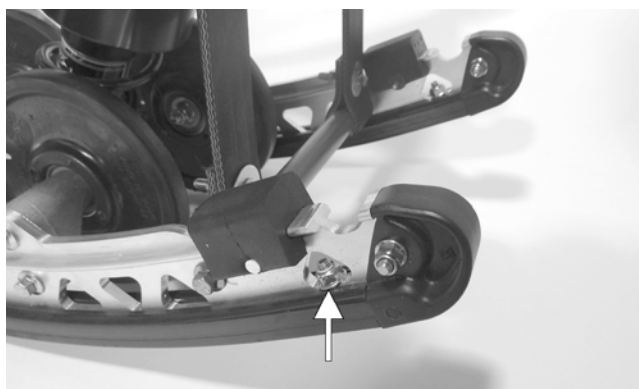

FZ096A

2. Align the wear strip with the openings (windows) in the track; then using a suitable driving tool, drive the wear strip rearward off the slide rail.

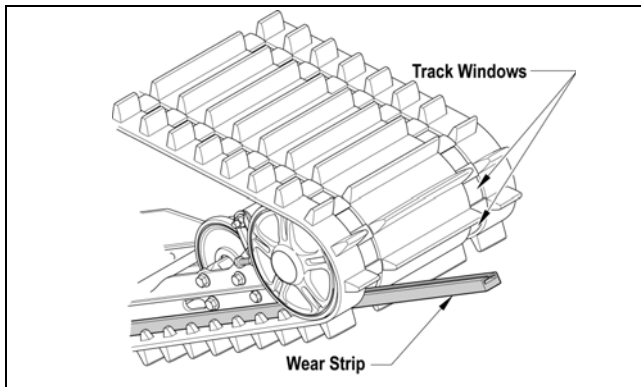

739-884A

CLEANING AND INSPECTING

1. Clean the slide rail using parts-cleaning solvent and compressed air.

⚠ WARNING

Always wear an approved pair of safety glasses when using compressed air.

2. Inspect the slide rail for cracks. If any cracks are found, replace the slide rail.
3. Using a straightedge, inspect the slide rail for any unusual bends. With the slide rail removed, place the straightedge along the bottom surface of the slide rail. If the rail is found to be bent, it must be replaced.

INSTALLING

NOTE: Use a file to remove any sharp edges on the lower portion of the rail.

1. Align the wear strip with the openings (windows) in the track and from the back, start the wear strip onto the rail; then using a block of wood and a hammer, drive the wear strip forward into position.
2. Secure with a machine screw and lock nut. Tighten to 50 in.-lb.

Shock Pads

REMOVING

1. Remove torx-head screws and nuts securing the shock pads.
2. Remove the rear shock pads.

INSPECTING

1. Inspect the pads for damage or wear.
2. Inspect the rivet holes in the slide rail for damage or elongation.

INSTALLING

1. Place the pads brackets into position on the slide rail.
2. Secure the pads with existing torx-head screws and nuts.

Idler Wheels/Mounting Blocks

REMOVING

1. Remove the cap screw and lock nut securing the idler wheel to the idler wheel mounting block; then remove the cap screw and lock nut securing the mounting block to the slide rail.

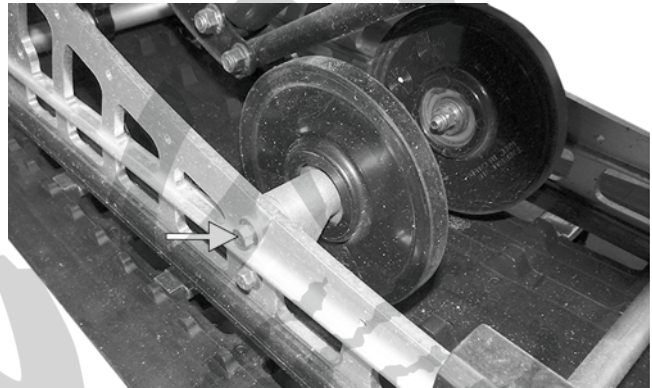

XM103A

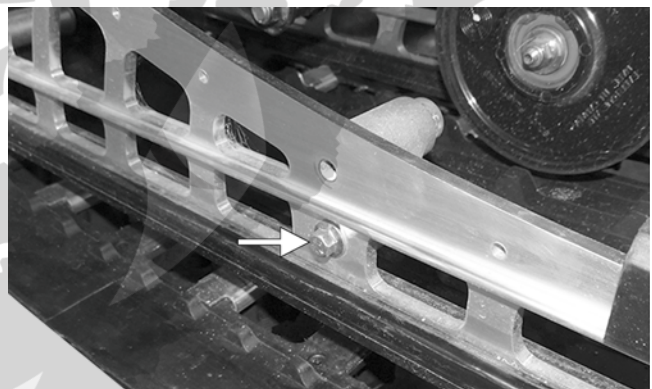

XM104A

2. Account for a flat washer from the idler wheel cap screw.

CLEANING AND INSPECTING

1. Clean the bearing with a clean cloth.
2. Inspect each idler wheel for cracks or damage.
3. Rotate the idler wheel bearing (by hand) and inspect for binding or roughness.

INSTALLING

1. Secure the mounting block on the slide rail with a cap screw and lock nut. Tighten to 12 ft-lb.

NOTE: For proper alignment, install an idler wheel cap screw into the top mounting block hole prior to tightening.

2. Place the idler wheel to the mounting block; then secure the idler wheel assembly with a cap screw, flat washer, and a lock nut. Tighten to 12 ft-lb.

Front Arm Assembly

■NOTE: To service the front arm assembly on the RR models, proceed to Front Arm Assembly (RR) in this sub-section.

REMOVING

1. With the skid frame removed, remove the cap screws and lock nuts securing the limiter straps to the front arm. Account for flat washers.
2. Remove the cap screw and lock nut securing the upper front shock absorber eyelet to the front arm. Pull the shock eyelet free of the bracket. Account for a sleeve.

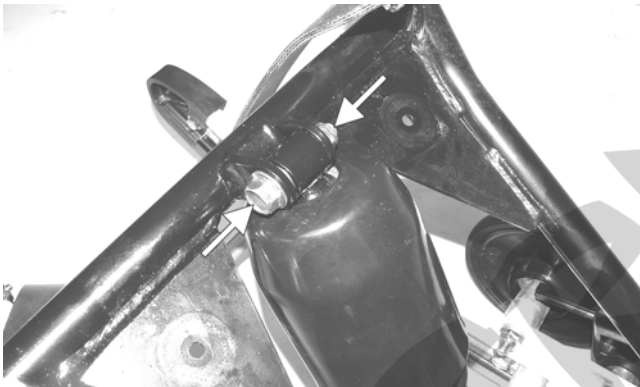

ZJ271A

3. Remove the lock nut and cap screw securing the rear shock pivot to the front arm.

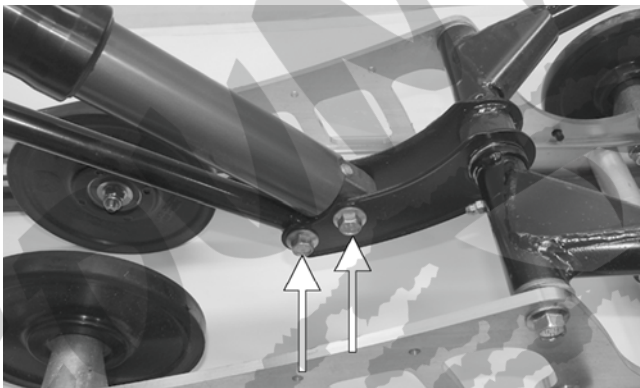

XM004A

4. Remove the cap screws securing the front arm to the rails.
5. Remove the front arm and account for the front arm axle.
6. Remove the cap screw securing the front outer idler wheel to the idler wheel mounting block. Account for lock nut, cap screw, and flat washer.
7. Remove the cap screw and lock nut securing the idler wheel mounting block to the slide rail.

8. Remove the cap screws, washer, and lock nut from the front shock axle; then from one side, tap the assembly forward far enough for the axle assembly to clear the slide rails. Account for an axle, two spacers, and two shim washers.

INSPECTING

1. Inspect all front arm weldments for cracks or unusual bends; then inspect the front arm mounting brackets for cracks and for elongated holes.
2. Closely inspect all tubing for cracks or unusual bends.
3. Inspect the bearings, bushings, and front arm spacers for wear or damage.
4. Inspect the shock absorber for damage and for any signs of oil leakage especially at the point where the shock shaft enters the shock body.
5. Inspect the shock absorber eyelet welds (at each end) for any cracks, signs of separation, or for unthreading.

INSTALLING

1. Place the front arm shock axle assembly into position on the skid frame making sure the spacers and washers are properly positioned. Secure with the cap screw, washer, and a new lock nut. Tighten to 40 ft-lb.
2. On the side that the idler wheel and mounting block were removed from, secure the mounting block on the slide rail with a cap screw and lock nut. Tighten to 20 ft-lb.

■NOTE: For proper alignment, install an idler wheel cap screw and lock nut into the top mounting block hole prior to tightening.

3. Secure the idler wheel to the mounting block with both existing cap screw. Tighten cap screws to 20 ft-lb.
4. Install the axle into the front arm; then position the front arm to the mounting location of the slide rail. Secure with cap screws and lock nuts. Tighten to 40 ft-lb.

■NOTE: Move the rear arm assembly forward enough to allow the rear arm springs to be installed into the slide blocks.

5. Secure the rear shock pivot to the front arm with cap screw and lock nut. Tighten to 20 ft-lb.

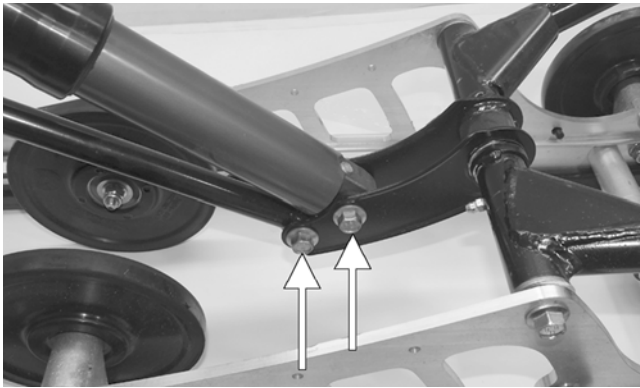

XM004A

- Secure the upper shock eyelet and axle in the mounting hole of the front arm. Secure with a cap screw and lock nut. Tighten securely.



ZJ271A

■NOTE: Do not over-tighten the shock absorber cap screw as the shock eyelet must be free to pivot.

- Secure the limiter straps to the front arm with cap screws, washers, and lock nuts. Tighten to 72 in.-lb.

Front Arm Assembly (RR)

REMOVING

- With the skid frame removed, remove the cap screws (A) and lock nuts securing the limiter straps to the front arm. Account for flat washers.

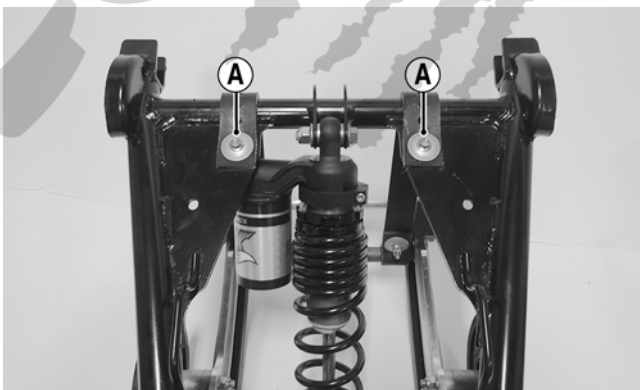

RR001A

- Remove the cap screw and lock nut securing the upper front shock absorber eyelet to the front arm. Pull the shock eyelet free of the bracket. Account for two spacers and two O-rings.
- Remove the cap screw (A) and axle (B) securing the front arm to the rails Account for two washers.

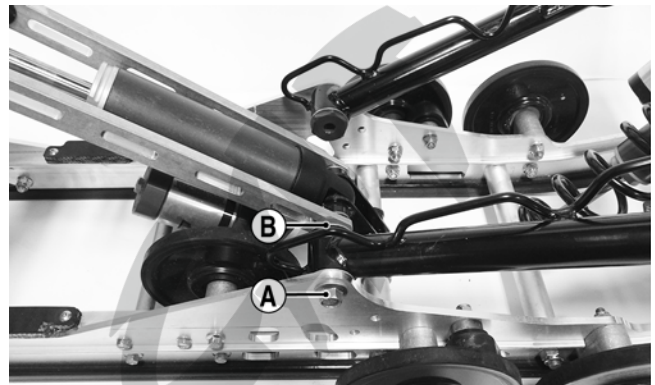

RR002A

INSPECTING

- Inspect all front arm weldments for cracks or unusual bends; then inspect the front arm mounting brackets for cracks and for elongated holes.
- Closely inspect all tubing for cracks or unusual bends.
- Inspect the bearings, bushings, and front arm spacers for wear or damage.

INSTALLING

- Install the existing washers onto both axles; then install the axles into the front arm and secure using existing cap screws (threads coated with blue Loctite #243). Tighten to 50 ft.-lb.



RR002

- Secure the front shock absorber to the front arm using existing cap screw and nut. Tighten to 20 ft.-lb.
- Secure the limiter straps to the front arm using existing cap screws, washers and nuts. Tighten to 72 in.-lb.

Rear Arm Assembly (ZR)

■NOTE: To service the rear arm assembly on the RR models, proceed to Rear Arm Assembly (RR) in this sub-section.

REMOVING

1. With the skid frame removed using the Rear Suspension Spring Tool, remove the spring from the adjusting cam.

WARNING

Care must be taken when removing the spring or damage or injury could result.

2. Mark the offset arm and the idler arm for assembly purposes.



FZ034

3. Loosen the cap screws and lock nuts securing the offset arm assembly to the idler arm; then remove the offset arm assembly. Account for a flanged axle, idler spacer, and washer.



FZ035A

4. Remove the idler wheel.

■NOTE: Use the Idler Wheel Puller Kit to remove the wheel.

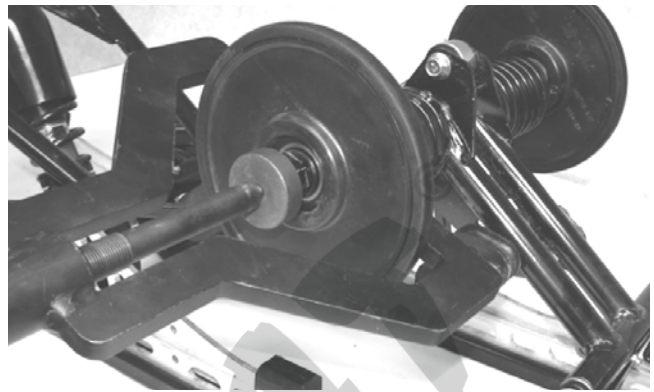

FZ037

5. Remove the cap screw, flat washer, and lock nut securing the spring slide to the slide rail. Account for the spring slide and all mounting hardware.

6. Remove the spring and sleeve from the idler arm.

■NOTE: Use the same procedure for the other side.

7. Remove the cap screw and lock nut securing the upper shock eyelet to the idler arm; then remove the cap screw and lock nut securing the upper shock link to the idler arm. Account for the cap screws, lock nuts, and sleeves.

8. Remove the cap screw (A) and lock nut securing the rear arm shock absorber to the rear shock pivot; then remove the cap screw (B) and lock nut securing the shock absorber link to the pivot and account for the cap screws, lock nuts, and sleeves.

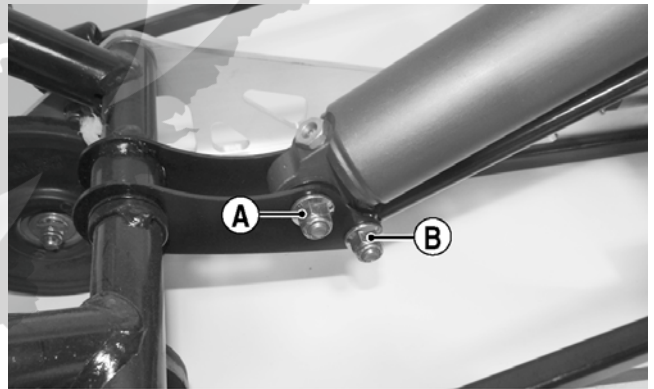

FZ102A

9. Remove the cap screw securing the rear arm to the idler arm. Account for the aluminum axle.

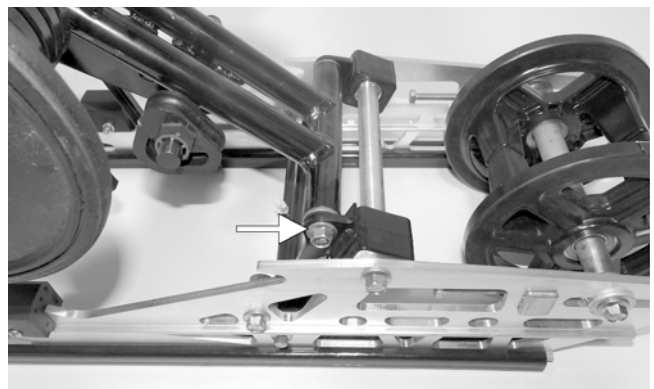

FZ101A

- Remove the cap screw and lock nut securing the rear arm to the slide rail. Account for the serrated axles and axle tube.



FZ103A

CLEANING AND INSPECTING

- Clean the bearings with a clean cloth.
- Inspect each idler wheel for cracks or damage.
- Inspect the bushings (located in the arm pivot area) for wear or damage.
- Inspect all welds and the tubing of the rear arm/idler arm for cracks or unusual bends.
- Inspect the two adjusting cams for damage.
- Rotate the idler wheel bearings (by hand) and check for binding or roughness.
- If a bearing must be replaced, see Idler Wheels/Mounting Blocks - Cleaning and Inspecting in this sub-section.

INSTALLING

- Place the rear arm assembly into position between the slide rails. Secure with a cap screw and lock nut. Tighten to 40 ft-lb.



FZ103A

- Install the rear arm onto the idler arm with an aluminum axle and two cap screws. Tighten to 40 ft-lb.

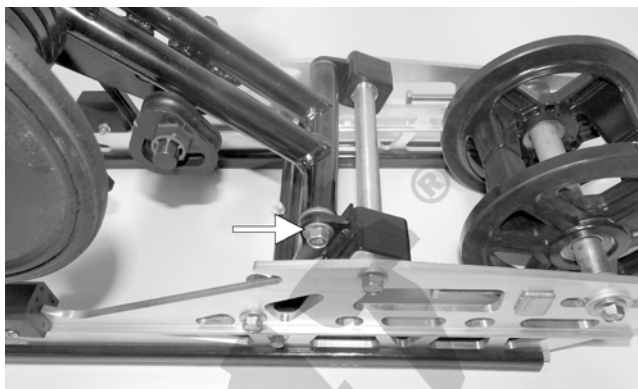

FZ101A

- With the sleeves installed, install the shock absorber link to the lower mounting hole of the rear shock pivot; then install the shock absorber with cap screws (A) and (B) and lock nuts. Tighten securely.

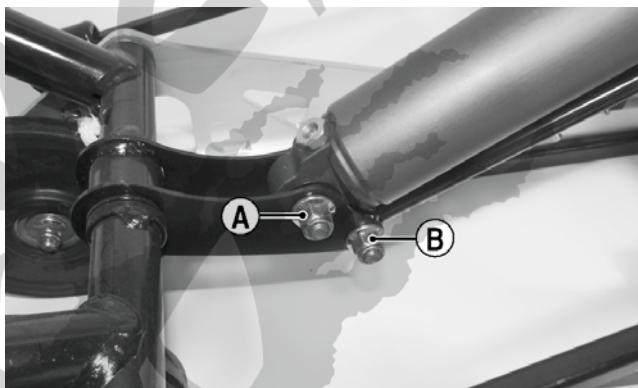

FZ102A

CAUTION

When installing the shock absorber link, note that the offset of the link eyelets are directed away from the rear arm shock absorber for proper clearance.

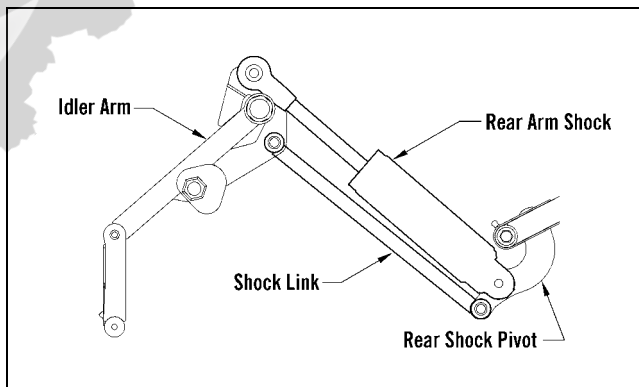

0742-877

- With the sleeves installed, install the shock absorber link to the lower mounting hole of the idler arm along with the cap screw and lock nut; then secure the shock absorber to the idler arm with cap screws and lock nuts. Tighten securely.

■NOTE: Do not over-tighten the shock absorber cap screw as the shock eyelet must be free to pivot.

■NOTE: Install the rear arm springs onto the adjuster blocks after the skid frame has been installed.

5. Slide the sleeve and spring onto the idler arm.
6. Place the spring slide and slide block (with spring in slide block) into position on the slide rail. Secure with a cap screw and washer. Tighten to 20 ft-lb.
7. With wheel insertion tool, install the rear upper idler wheel on the idler arm.

CAUTION

When driving the idler wheel onto the idler arm, use a tool to contact the inside race of the bearing or damage to the wheel or bearing may occur.

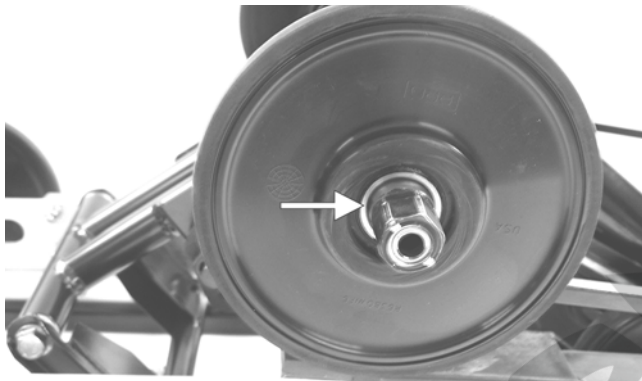

MS072A

8. Install the idler spacer collar onto the idler arm.



FZ047

9. Place the flared bushing with a thin flat washer through the notched side of the offset arm assembly.

■NOTE: If the flared bushing in the offset arm is loose, it must be cleaned and green Loctite #609 must be applied to it prior to installation.

10. Align the marks on the idler arm to the centerline of the offset arm assembly. Secure the offset arm to the idler arm with cap screws and lock nuts. Tighten to 20 ft-lb.

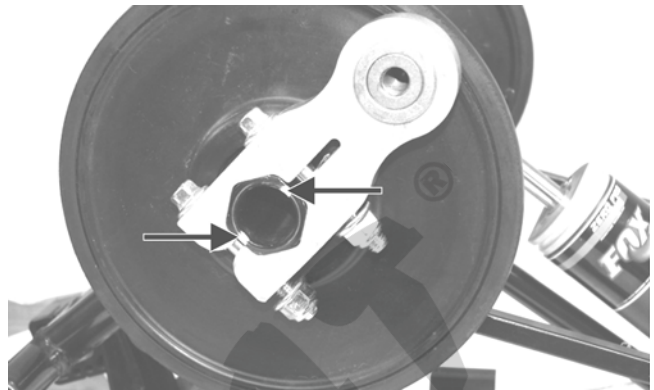

FZ048A

■NOTE: When tightening the offset arm lock nuts, tighten the upper lock nut first to ensure an even clamp load. Make sure the flared side of the bushing is directed outward.

11. Grease the idler arm and rear arm grease fittings with an all-temperature grease.

Rear Arm Assembly (RR)

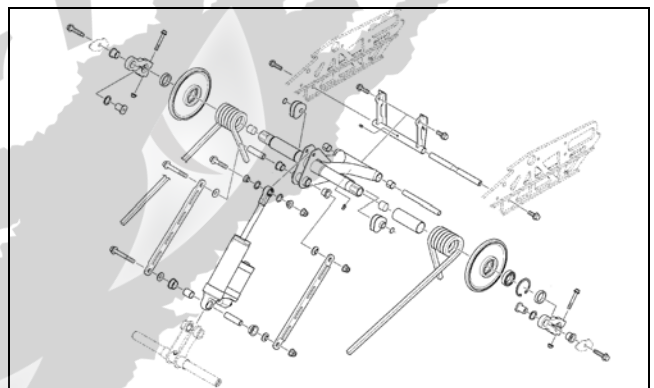

SNO-265

REMOVING

1. With the skid frame removed using the Rear Suspension Spring Tool, remove the springs from the adjusting cams.

⚠ WARNING

Care must be taken when removing the spring or damage or injury could result.

2. Mark the offset arm and the idler arm for assembly purposes.



FZ034

3. Loosen the cap screws and lock nuts securing the offset arm assembly to the idler arm; then remove the offset arm assembly. Account for a flanged axle, idler spacer, and washer.
4. Remove the upper idler wheel.
5. Remove the spring and sleeve from the idler arm. Repeat for opposite side.
6. Remove the cap screw and lock nut securing the upper rear shock absorber eyelet to the rear arm. Account for two spacers and two O-rings.

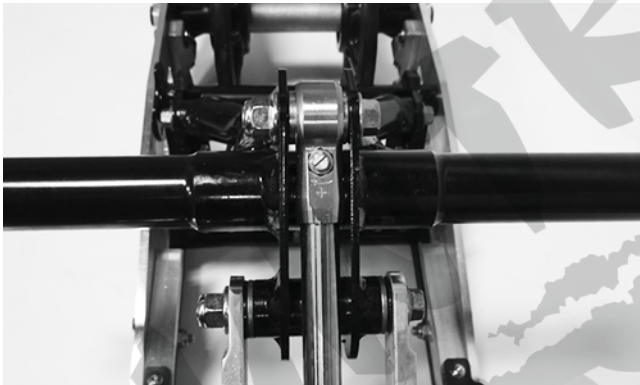

XM089

7. Remove the cap screw and nut securing the rear shock links to the rear arm. Account for one axle.
8. Remove the cap screw securing the rear arm to the idler arm. Account for the aluminum axle.
9. Remove the cap screw and lock nut securing the rear arm to the slide rail. Account for the axle tube.

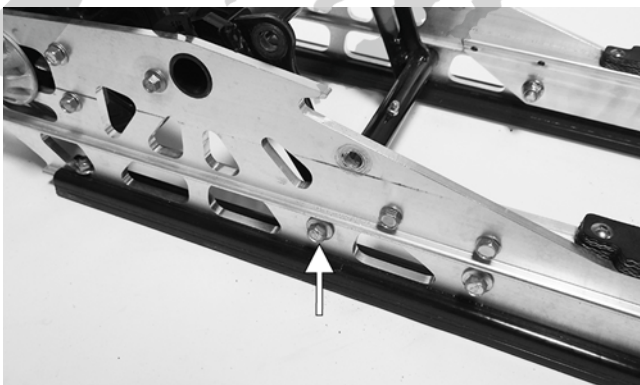

XM090A

INSTALLING

1. Slide the axle tube into the rear arm; then position the rear arm with the holes in the slide rails. Secure using existing cap screws (threads coated with blue Loctite #243. Tighten to 20 ft-lb.

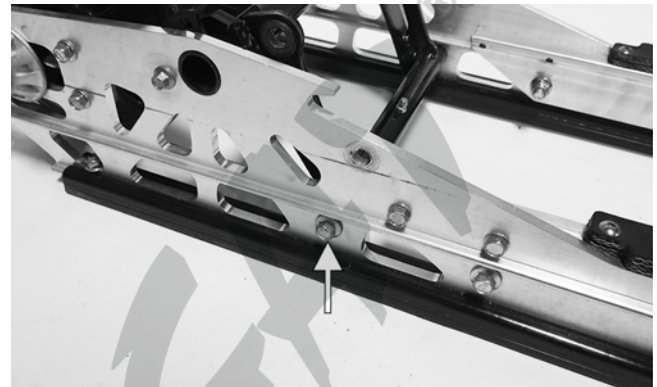

XM090A

2. Install the aluminum axle into the idler arm; then position the idler arm between the rear arm and secure using existing cap screws (thread coated with blue Loctite #243. Tighten to 40 ft-lb.
3. Loosely secure the rear shock links to the idler arm using existing cap screw and nut.
4. With both O-rings and spacers, secure the rear shock absorber to the idler arm using existing cap screws and lock nut. Tighten to 40 ft-lb.

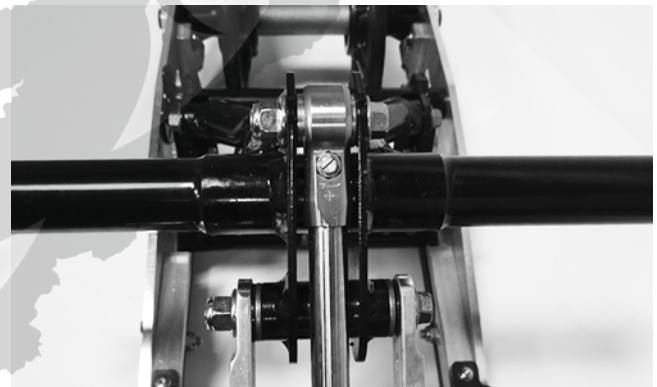

XM089

5. Install both spring sleeves onto the rear arm; then install the suspension springs into the spring slides then onto the idler arm.
6. Install spacers onto the idler arm.
7. Align the marks on the idler arm to the centerline of the offset arm assembly. Secure the offset arm to the idler arm with cap screws and lock nuts. Tighten to 20 ft-lb.

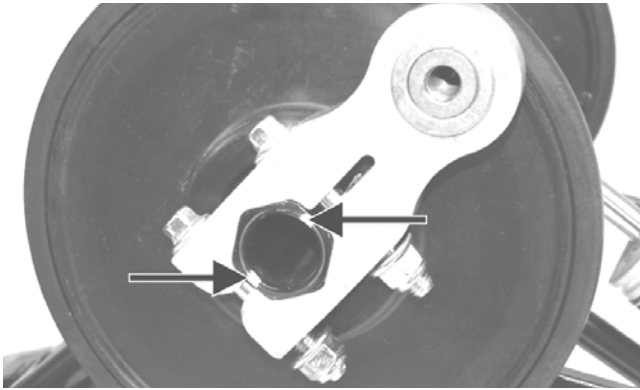

FZ048A

■NOTE: When tightening the offset arm lock nuts, tighten the upper lock nut first to ensure an even clamp load. Make sure the flared side of the bushing is directed outward.

- Grease the idler arm and rear arm grease fittings with an all-temperature grease.

Rear Arm Assembly (M/XF)

DISASSEMBLING

- With the skid frame removed, remove the snap ring securing the rear arm idler wheels to the inner carriage axle and account for the wave washers; then remove the axle from the idler arm.

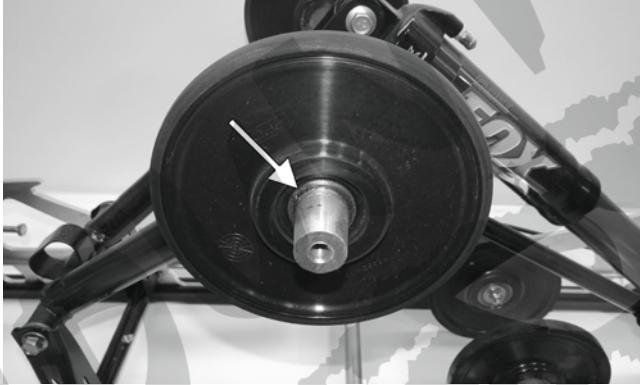

XM001A



CM232

- Remove the cap screw and lock nut securing the upper shock eyelet to the idler arm; then remove the cap screw and lock nut securing the rear shock link to the idler arms.

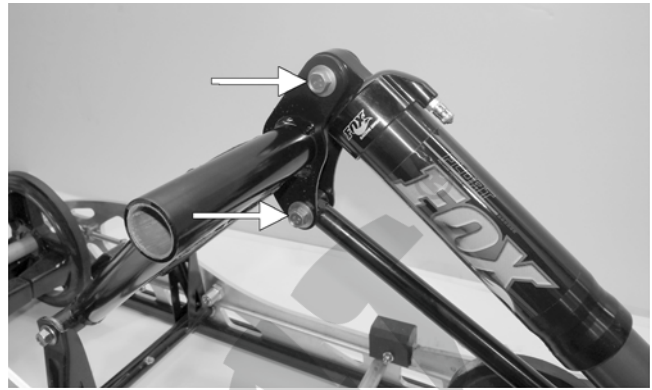

XM003A

- Remove the cap screws and lock nuts securing the rear arm shock absorber and shock link to the offset arm.

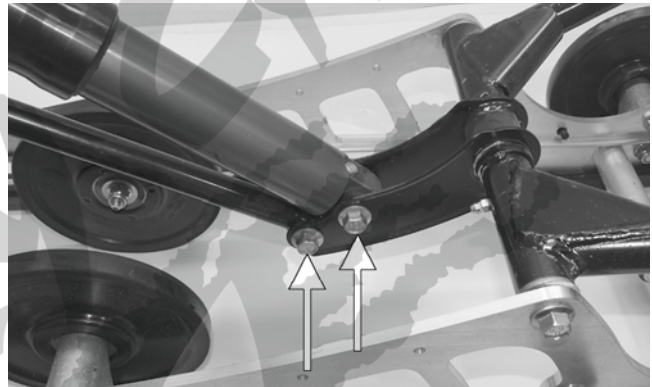

XM004A

■NOTE: With the rear arm shock and shock link removed, account for the four sleeves.

- Remove the cap screw and lock nut securing the rear arm to the idler arm. Account for the aluminum axle and flared bushings.

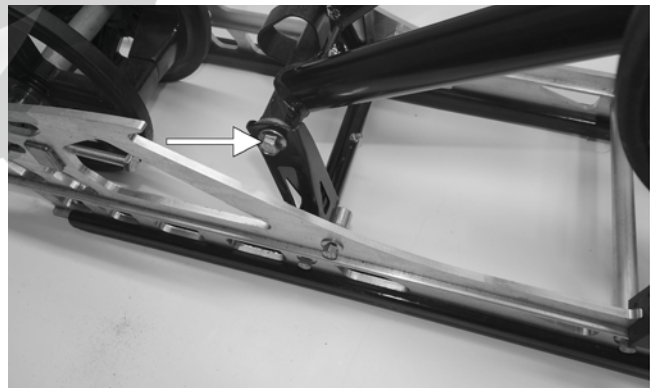

XM006A

■NOTE: To loosen and remove the remaining cap screw from the rear arm/idler arm, it may be necessary to reinstall the cap screw.

- Remove the cap screw and lock nut securing the rear arm to the slide rail. Account for the bushings and axle tube.

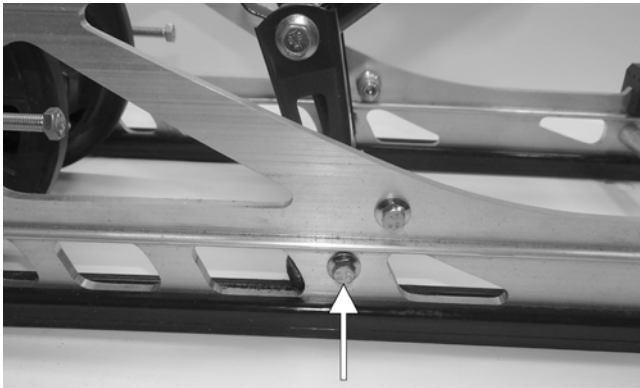

XM007A

CLEANING AND INSPECTING

1. Clean the bearings with a clean cloth.
2. Inspect each idler wheel for cracks or damage.
3. Inspect the bushings (located in the arm pivot area) for wear or damage.
4. Inspect all welds and the tubing of the upper arm for cracks or unusual bends.
5. Inspect the two adjusting cams for damage.
6. Rotate the idler wheel bearings (by hand) and check for binding or roughness.
7. If a bearing must be replaced, see Idler Wheels/ Mounting Blocks - Cleaning and Inspecting in this sub-section.

ASSEMBLING

1. Place the rear arm assembly into position between the slide rails. Secure with existing cap screws. Tighten to 20 ft-lb.



XM007A

2. Install the idler arm onto the rear arm with an aluminum axle, bushing assemblies, and two cap screws. Tighten to 40 ft-lb.

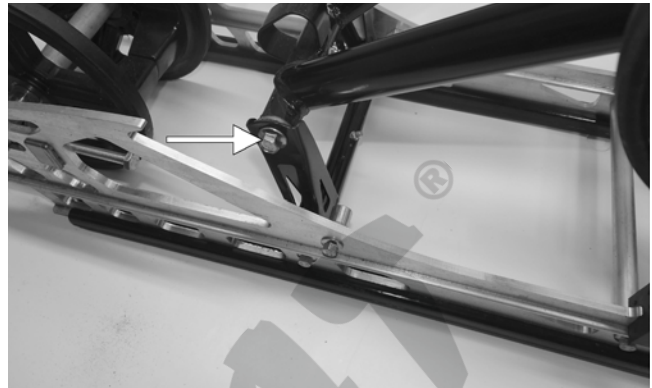

XM006A

3. With the sleeves installed, place the shock absorber and shock link between the offset arm bracket. Secure with the cap screws and lock nuts. Tighten securely.

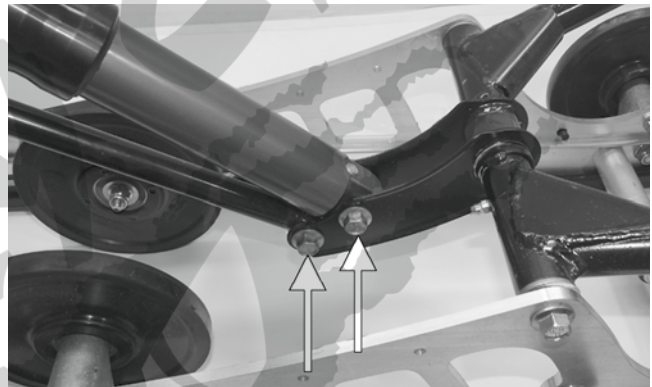

XM004A

■ **NOTE: Do not over-tighten the shock absorber cap screw as the shock eyelet must be free to pivot.**

4. With the sleeves installed, position the shock link in the appropriate holes of the idler arm brackets and shock absorber; then insert the cap screw through the eyelets. Secure with the cap screws and lock nuts. Tighten securely.

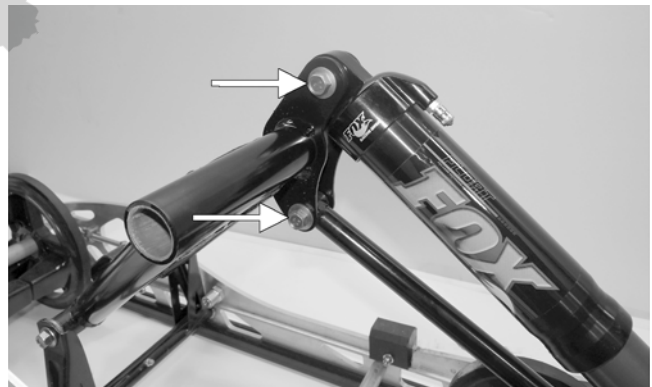

XM003A

5. Install the inner carriage axle to the idler arm; then install a wave washer and idler wheel. Secure with the snap ring.



XM002

- Turn the slide rail onto the side the idler wheel was installed in (from step 5); then with a block of wood placed under the inner carriage axle/idler arm, install a wave washer.



XM005

- Install the remaining idler wheel along with the snap ring onto the axle; then using a suitable driving tool, carefully drive the snap ring into the idler wheel until properly seated in the groove of the axle.

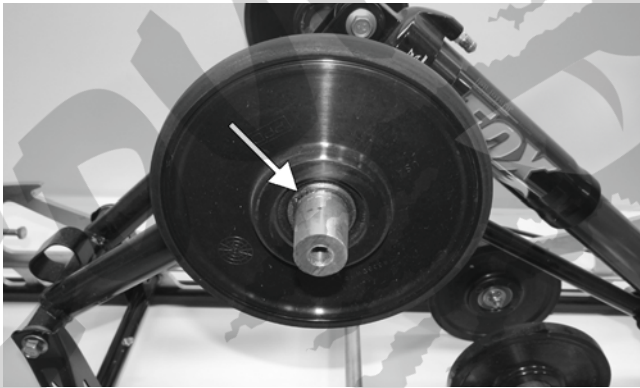

XM001A

- Grease the idler arm and rear arm grease fittings with an all-temperature grease.

Rear Axle/Idler Wheels

DISASSEMBLING REAR AXLE

- Remove both cap screws and washers and securing rear wheel assembly to the rails.

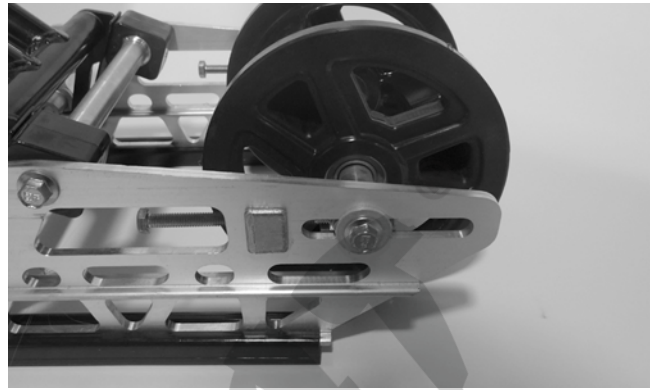

FZ104

- Loosen the track adjusting bolts then carefully remove the rear axle assembly from the skid frame.

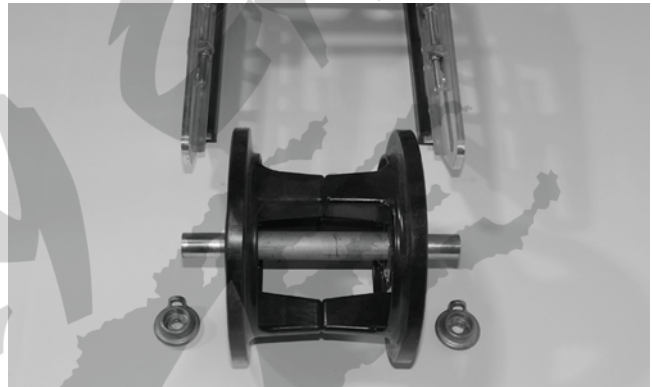

ZJ266

ASSEMBLING REAR AXLE

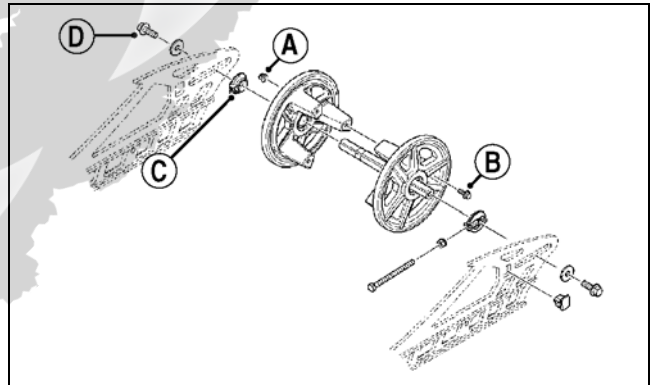

SNO-2239A

- If the rear idler wheels were separated, install both wheels onto the axle and secure using the existing cap screws (B) and nuts (A). Tighten to 80 in.-lb.
- Place the adjuster bushings (C) on the axle; then install the idler wheels and secure with two cap screws (D) (coated with blue Loctite #243) and flat washers. Tighten cap screws only until snug.

■NOTE: Tighten the rear idler wheel axle only until snug until the skid frame has been installed and track tension has been adjusted; then the axle assembly must be tightened to 34 ft-lb.

- Install the skid frame.

Installing Skid Frame

1. Using a piece of cardboard on the floor to protect against scratching and an appropriate handlebar/steering post stand, tip the snowmobile onto one side.
2. Pull the track away from the tunnel and spread open; then place the skid frame into the track.
3. On the ZR, position the front of the skid frame into the tunnel and engage the front arm with the slider axle in the tunnel.

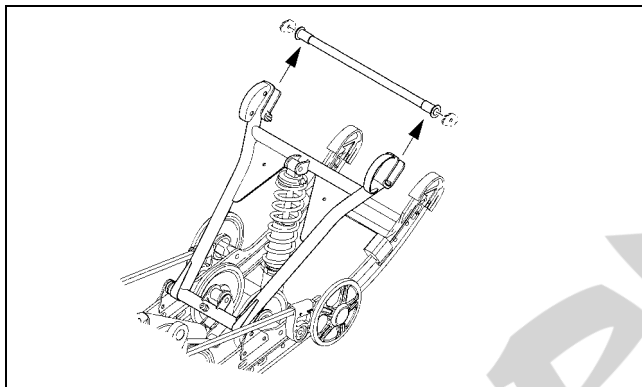

0742-187

4. On the M and XF, secure the front of the skid frame to the tunnel using the existing cap screws, flat washers, and lock nuts.

■NOTE: To aid in centering the front arm with the hole in the tunnel, position the skid frame and track at a 45° angle to the bottom of the tunnel.

5. Push the rear of the skid frame and the track into the tunnel.
6. Align the rear arm assembly with the appropriate hole in the tunnel. Secure the rear arm assembly with a cap screw, lock washer, and flat washer. AT THIS TIME, TIGHTEN ONLY UNTIL SNUG.
7. Tip the snowmobile onto the other side; then align the offset arm assembly with the appropriate hole in the tunnel. Secure the rear arm assembly with a cap screw, lock washer, and flat washer. AT THIS TIME, TIGHTEN ONLY UNTIL SNUG.

■NOTE: Do not install the short legs of the rear springs onto the adjusting cams at this time.

8. At this time, place the snowmobile to the upright position; then tighten all cap screws to 40 ft-lb.
9. On the ZR, using the Rear Suspension Spring Tool, install the short legs of the rear springs onto the adjusting cams making sure the cams are in the same adjustment positions.
10. Adjust track tension and track alignment.

CAUTION

After proper track tension and alignment have been attained, make certain that the rear axle cap screws tightened to specifications or component damage will occur.

Servicing IFP Shock

SPECIAL TOOLS

A number of special tools must be available to the technician when servicing the rear suspension.

Description	p/n
Floating Piston Location Gauge Tool	0644-350
Floating Piston Depth Tool	0644-575
Inflation Needle Tool	0744-020
Rear Suspension Spring Tool	0144-311
Shock Body Clamping Tool	0644-486
Shock Rod Clamp Tool	0644-425
Bearing Cap Seal Protector Tool	0644/268/403/404
Shock Spring Removal Tool	0644-057

■NOTE: Special tools are available from the Arctic Cat Service Parts Department.

■NOTE: If service work is needed on any FOX shocks, the shock will have to be removed and sent to FOX or any FOX distributor for any service work. For FOX shock information log on to www.ridefox.com.

WARNING

Before any service is performed on the gas shock absorber, first discharge all pressure from the shock remote reservoir. Remove the valve screw from the pressure valve and insert the Inflation Needle. Open valve until all pressure is released. Failure to do this may cause personal injury.

REMOVING/CLEANING

1. Remove the shock from the snowmobile; then remove the spring from the shock body using the shock spring removal tool.
2. Wash the shock body in parts-cleaning solvent.

DISASSEMBLING

1. Remove the screw from the bottom of the shock. Discharge all the pressure from the shock using the Inflation Needle. Open the valve in filler handle until all pressure is released.

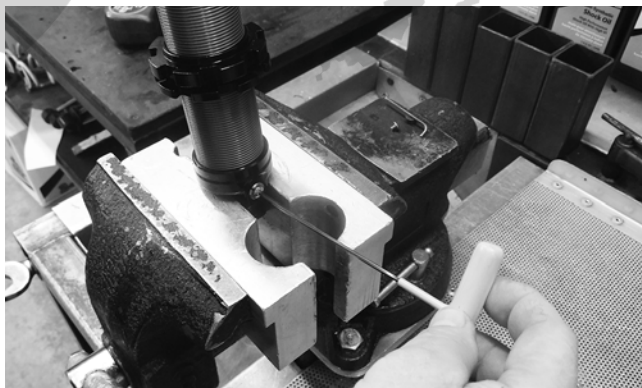

ZR-004

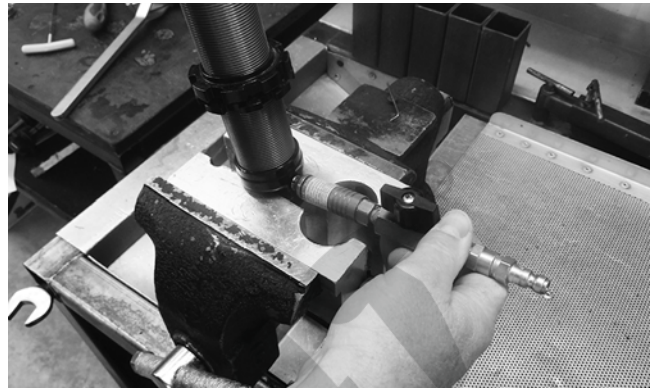

ZR-017

2. Using a 1-in. wrench, loosen the bearing assembly and remove the shock rod and valve assembly from the shock body.



ZR-003



ZR-016

3. Pour the oil from the shock body into a suitable container; then hang the shock body upside down and let it drip into the container.
4. Clamp the shock rod and valve assembly in bench vise; then remove the nut securing the valve stack.



ZR-011



ZR-014

NOTE: Placing the valve stack on a screwdriver when removing from the shock rod will allow the shims and valve to stay in order.

5. Remove the bearing end cap.
6. Items to inspect:
 - A. Shock rod for straightness, nicks, or burrs.
 - B. Bearing end cap — clean, inspect, or replace.
 - C. Inside of shock body for scratches, burrs, or excessive wear.
 - D. Piston strap for cuts, chipped or nicked edges, or excessive wear.
 - E. O-rings for nicks, cuts, or cracks.
 - F. Valves for kinks or waves.
 - G. Rubber damper (ski shocks only) for chipping, cracking, or being missing.
7. Items to replace:
 - A. Floating piston O-ring.
 - B. Shock shaft bearing cap if any signs of oil leaks or damage.
 - C. Any part worn or damaged.

ASSEMBLING

1. Lubricate the O-rings in the bearing end cap; then install the bearing cap seal protector onto the end of the shock rod. Install the bearing end cap.



ZR-013

2. Install the valve stack onto the shock rod; then secure using the existing nut. Tighten to 15 ft-lb.



ZR-010

3. Using tape measure, make sure the floating piston is at the correct depth in the shock body (according to the chart in the specifications section of the manual).



ZR-009

4. If the floating piston is not at the correct depth, use the floating piston location gauge to set the piston to the correct depth in the shock body.



ZR-008

5. Fill shock body with new synthetic shock oil to bottom of threads.



ZR-007

6. With the bearing cap positioned at the top of the shock rod, install the piston/valve stack into the shock body; then gently tap the top of the rod eyelet with a soft hammer until the piston/valve stack is just below the oil.

■NOTE: Using a torch, carefully wave the flame over the top of the shock oil to remove any air bubbles.



ZR-006

7. Slide the bearing cap down to the shock body and into the oil; then while holding the shock rod in place, begin to thread the cap into the body. As the cap threads into the body, oil will escape. Lift slightly on the shaft while threading until the O-ring contacts the shock body. Tighten the bearing cap to 50 ft-lb.



ZR-003

8. With shock oil around the seals in the bearing cap and on the shock rod, slowly compress the shock rod until the shock eyelet bottoms out. Pressurize the shock with nitrogen to 200 psi and until the shock eyelet fully extends.

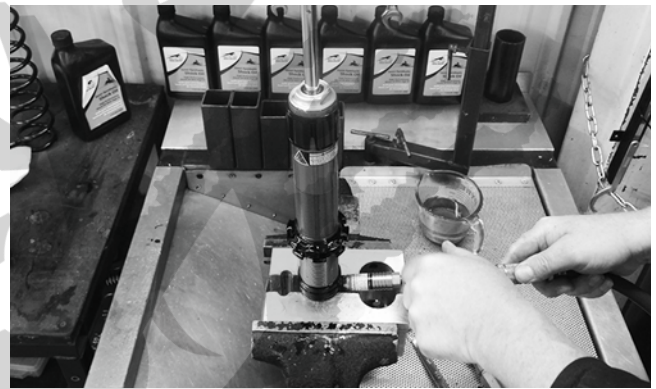

ZR-018

9. Install the screw into the shock body.

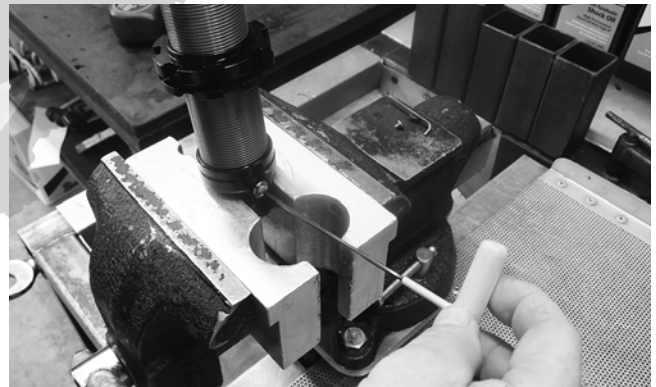

ZR-004

10. Compress the shock eyelet until it bottoms out; then the shock eyelet should fully extended. Wash the shock and install the spring.

INSTALLING

1. Place the shock into position on the snowmobile.
2. Secure with existing hardware and bushings.

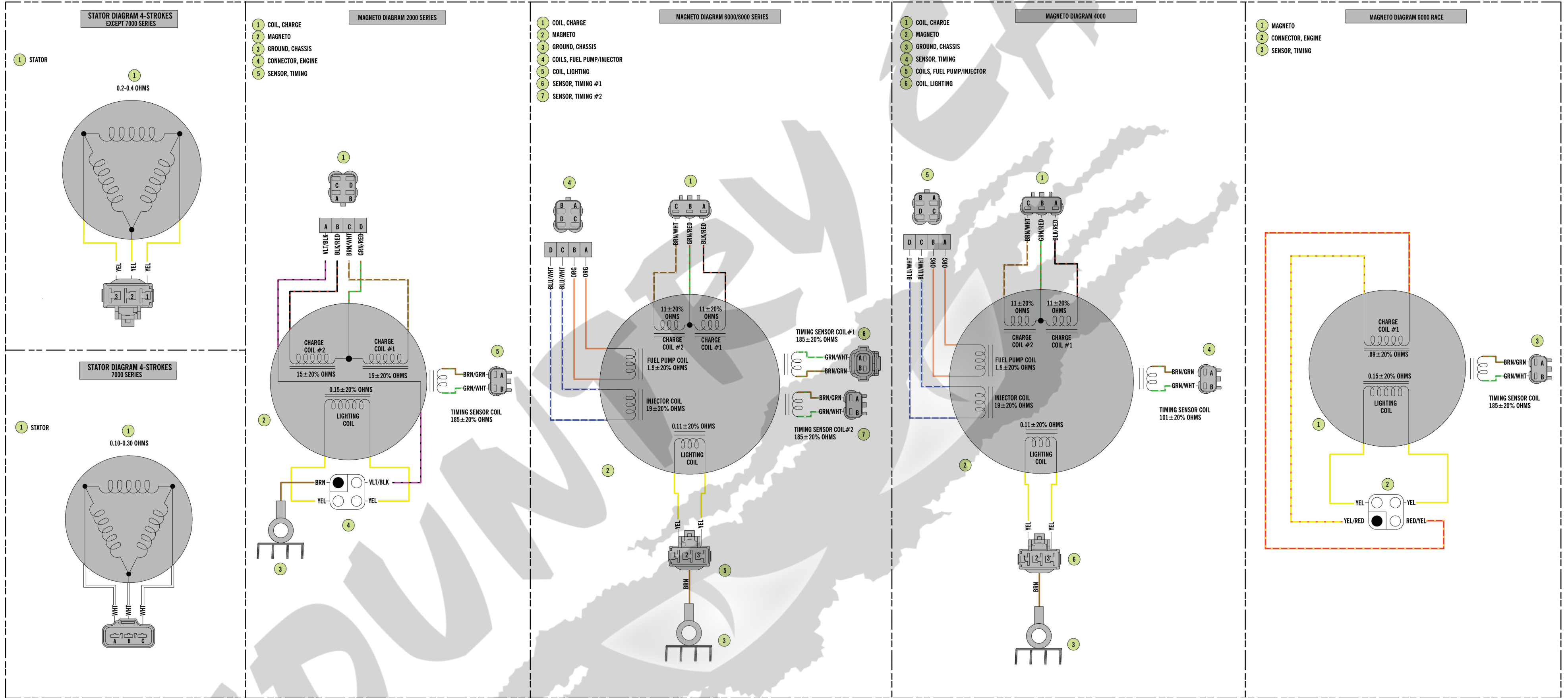

NOTES:
1. CONNECTORS SHOWN FROM MATING SURFACE SIDE, WHERE APPLICABLE.
2. ● MALE PIN TERMINAL
○ FEMALE RECEPTACLE TERMINAL

Main Harness (p/n 1686-747) ZR 4000/RR

- 1 THROTTLE POSITION SENSOR
- 2 SENSOR, COOLANT TEMPERATURE
- 3 CONNECTOR, PULSER COIL
- 4 CONNECTOR, FUEL PUMP INJECTOR
- 5 INJECTOR, PTO
- 6 INJECTOR, MAG
- 7 CONNECTOR, ECU #1
- 8 CONNECTOR, FUEL PUMP/LEVEL SENDER
- 9 CONNECTOR, CHARGE COIL
- 10 CONNECTOR, ECU #2
- 11 FUSE HOLDER
- 12 CONNECTOR, CCU
- 13 CONNECTOR, DIAGNOSTIC
- 14 CONNECTOR, REVERSE ACTUATOR
- 15 SWITCH, REVERSE GEAR
- 16 CONNECTOR, ACCESSORY/TETHER
- 17 ALARM, REVERSE
- 18 SWITCH, SPEED
- 19 CONNECTOR, CHASSIS GROUND
- 20 SENSOR, OIL LEVEL
- 21 CONNECTOR, CONSOLE HARNESS
- 22 CONNECTOR, HANDLEBAR HARNESS
- 23 TAILLIGHT
- 24 COIL, HV IGNITION

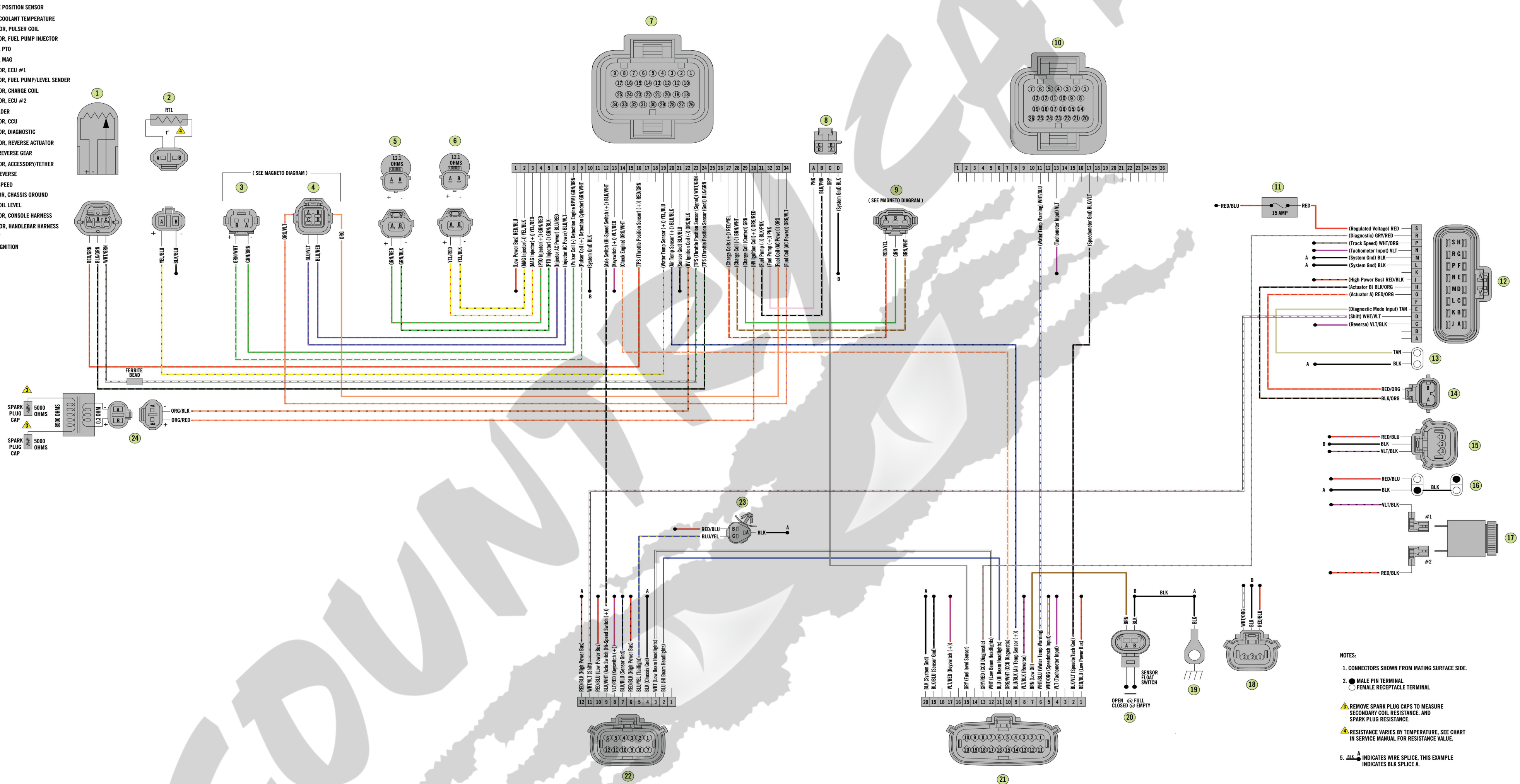

- NOTES:
1. CONNECTORS SHOWN FROM MATING SURFACE SIDE.
 2. ● MALE PIN TERMINAL
○ FEMALE RECEPTACLE TERMINAL
 3. REMOVE SPARK PLUG CAPS TO MEASURE SECONDARY COIL RESISTANCE AND SPARK PLUG RESISTANCE.
 4. RESISTANCE VARIES BY TEMPERATURE. SEE CHART IN SERVICE MANUAL FOR RESISTANCE VALUE.
 5. A INDICATES WIRE SPLICE, THIS EXAMPLE INDICATES BLK SPLICE A.

Main Harness (p/n 1686-724)

M 8000 SP LTD **XF 8000 SP LTD**
XF 8000 CT **XF 8000 HC SP LTD**
XF 8000 LXR **ZR 8000 LXR/SP LTD/SP LTD ET**
XF CC SP LTD

- 1 SENSOR, THROTTLE POSITION
- 2 CONNECTOR, TIMING SENSOR #1
- 3 CONNECTOR, TIMING SENSOR #2
- 4 CONNECTOR, FUEL PUMP INJECTOR COILS
- 5 INJECTOR, PTO
- 6 INJECTOR, MAG
- 7 CONNECTOR, ECU #1
- 8 CONNECTOR, CHARGE COIL
- 9 CONNECTOR, FUEL PUMP
- 10 CONNECTOR, ECU #2
- 11 CONNECTOR, DIAGNOSTIC
- 12 CONNECTOR, KNOCK SENSOR
- 13 SERVO MOTOR, APV
- 14 ALARM, REVERSE
- 15 CONNECTOR, ACCESSORY
- 16 PLUG, TETHER
- 17 SENSOR, OIL LEVEL
- 18 CONNECTOR, SPEED SENSOR
- 19 CONNECTOR, CONSOLE HARNESS
- 20 CONNECTOR, TAILLIGHT
- 21 CONNECTOR, HANDLEBAR HARNESS
- 22 STARTER RELAY, #1
- 23 STARTER RELAY, #2
- 24 STARTER RELAY, #2
- 25 POWER DISTRIBUTION MODULE
- 26 CONNECTOR, BATTERY POSITIVE
- 27 CONNECTOR, BATTERY NEGATIVE
- 28 CONNECTOR, DC REGULATOR #2
- 29 CONNECTOR, AC REGULATOR #1
- 30 REGULATOR
- 31 CONNECTOR, LIGHTING COIL
- 32 CONNECTOR, CHASSIS GROUND
- 33 SENSOR, EXHAUST TEMPERATURE
- 34 SENSOR, COOLANT TEMPERATURE
- 35 COIL, MAG. HV IGNITION #2
- 36 COIL, MAG. HV IGNITION #1
- 37 COIL, PTO, HV IGNITION #2
- 38 COIL, PTO, HV IGNITION #1

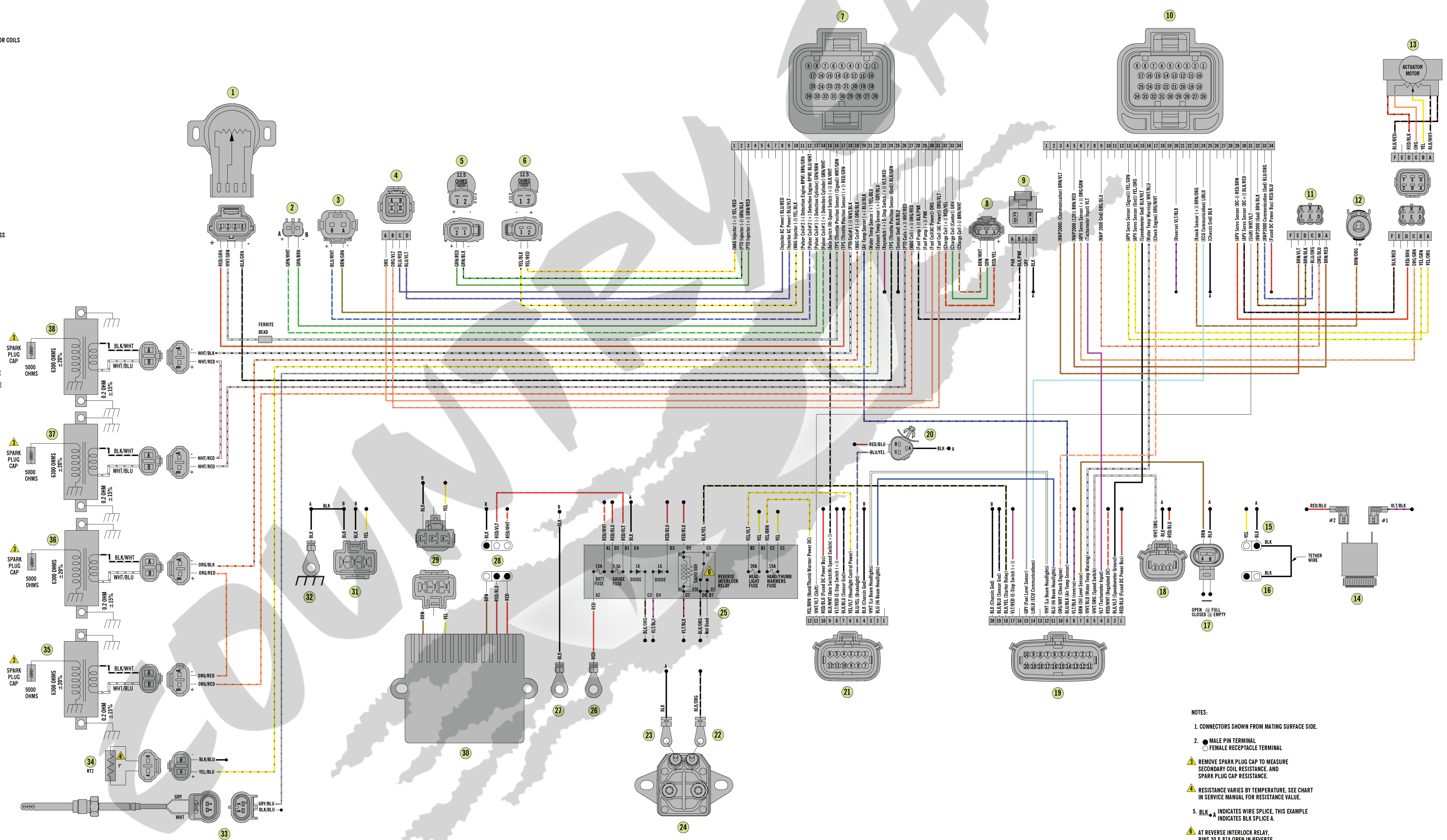

- NOTES:**
- 1 CONNECTORS SHOWN FROM MATING SURFACE SIDE.
 - 2 ● MALE PIN TERMINAL
○ FEMALE RECEPTACLE TERMINAL
 - ▲ REMOVE SPARK PLUG CAP TO MEASURE SECONDARY COIL RESISTANCE AND SPARK PLUG CAP RESISTANCE.
 - ▲ RESISTANCE VARIES BY TEMPERATURE. SEE CHART IN SERVICE MANUAL FOR RESISTANCE VALUE.
 5. BLK/A INDICATES WIRE SPLICE, THIS EXAMPLE INDICATES BLK SPLICE A.
 - ▲ AT REVERSE INTERLOCK RELAY, PINS 30 & 31A OPEN IN REVERSE (ELECTRIC START DISABLED) PINS 30 & 31A CLOSED IN FORWARD (ELECTRIC START ENABLED)

Main Harness (p/n 1686-707) M 6000 ES XF 6000 CT/LXR/SP/SP LTD ZR 6000 LXR/SP/SP LTD/SP LTD ET ES

- 1 SENSOR, TMAP
- 2 SENSOR, COOLANT TEMPERATURE
- 3 SENSOR, EXHAUST TEMPERATURE
- 4 CONNECTOR, TIMING SENSOR #1
- 5 CONNECTOR, TIMING SENSOR #2
- 6 CONNECTOR, FUEL PUMP INJECTOR COILS
- 7 HARNESS, INJECTOR
- 8 INJECTOR, PTO
- 9 INJECTOR, MAG
- 10 CONNECTOR, ECU #1
- 11 SENSOR, THROTTLE POSITION
- 12 CONNECTOR, CHARGE COIL
- 13 COIL, MAG. IGNITION
- 14 COIL, PTO. IGNITION
- 15 CAP, SPARK PLUG
- 16 CONNECTOR, SPEED SENSOR
- 17 CONNECTOR, OIL PUMP
- 18 CONNECTOR, ECU #2
- 19 CONNECTOR, DIAGNOSTIC
- 20 CONNECTOR, DIAGNOSTIC POWER
- 21 CONNECTOR, KNOCK SENSOR
- 22 CONNECTOR, ISC
- 23 SERVO MOTOR, APV
- 24 ALARM, REVERSE
- 25 SENSOR, OIL LEVEL
- 26 CONNECTOR, CONSOLE HARNESS
- 27 RELAY, STARTER
- 28 CONNECTOR, ACCESSORY
- 29 CONNECTOR, FUEL PUMP/LEVEL SENSOR
- 30 CONNECTOR, TAILLIGHT
- 31 CONNECTOR, TAILLIGHT HARNESS
- 32 CONNECTOR, HANDLEBAR HARNESS
- 33 PDM
- 34 CONNECTOR, BATTERY POSITIVE
- 35 CONNECTOR, BATTERY NEGATIVE
- 36 CONNECTOR, CHASSIS GROUND
- 37 CONNECTOR, DC REGULATOR
- 38 CONNECTOR, BATTERY CHARGE
- 39 CONNECTOR, STATOR
- 40 REGULATOR

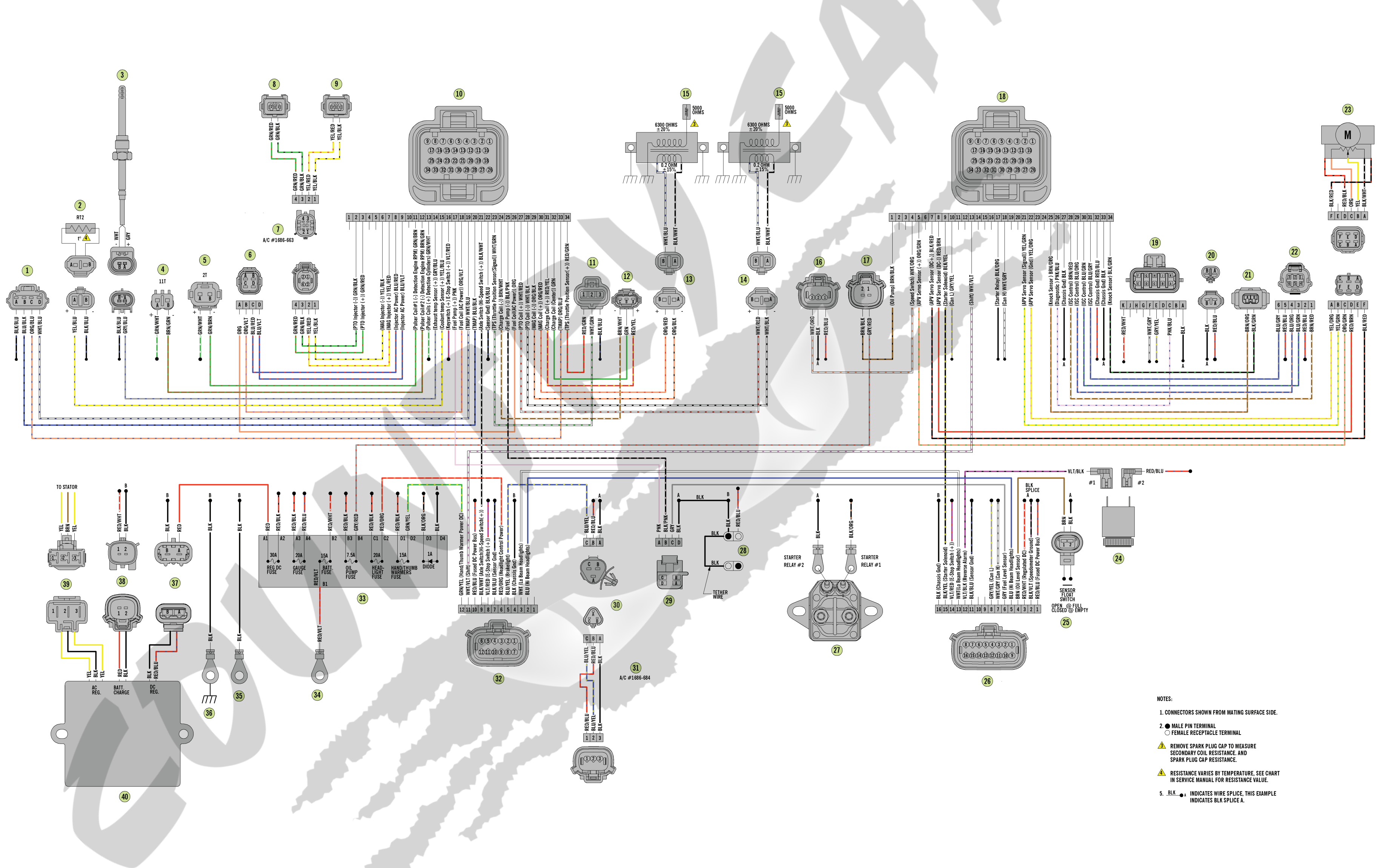

- NOTES:
1. CONNECTORS SHOWN FROM MATING SURFACE SIDE.
 2. ● MALE PIN TERMINAL
○ FEMALE RECEPTACLE TERMINAL
 - ▲ REMOVE SPARK PLUG CAP TO MEASURE SECONDARY COIL RESISTANCE, AND SPARK PLUG CAP RESISTANCE.
 - ▲ RESISTANCE VARIES BY TEMPERATURE. SEE CHART IN SERVICE MANUAL FOR RESISTANCE VALUE.
 5. **BLK** ● INDICATES WIRE SPLICE, THIS EXAMPLE INDICATES BLK SPLICE A.

Main Harness (p/n 1686-710) M 6000/SP XF 6000 CC SP/HC SP ZR 6000 SP RR/TH

- 1 SENSOR, TMAP
- 2 SENSOR, COOLANT TEMPERATURE
- 3 SENSOR, EXHAUST TEMPERATURE
- 4 CONNECTOR, TIMING SENSOR #1
- 5 CONNECTOR, TIMING SENSOR #2
- 6 CONNECTOR, FUEL PUMP INJECTOR COILS
- 7 HARNESS, INJECTOR
- 8 INJECTOR, PTO
- 9 INJECTOR, MAG
- 10 CONNECTOR, ECU #1
- 11 SENSOR, THROTTLE POSITION
- 12 CONNECTOR, CHARGE COIL
- 13 COIL, MAG. IGNITION
- 14 COIL, PTO. IGNITION
- 15 CAP. SPARK PLUG
- 16 CONNECTOR, SPEED SENSOR
- 17 CONNECTOR, OIL PUMP
- 18 CONNECTOR, ECU #2
- 19 CONNECTOR, DIAGNOSTIC
- 20 CONNECTOR, DIAGNOSTIC POWER
- 21 CONNECTOR, KNOCK SENSOR
- 22 CONNECTOR, ISC
- 23 SERVO MOTOR, APV
- 24 ALARM, REVERSE
- 25 SENSOR, OIL LEVEL
- 26 CONNECTOR, CONSOLE HARNESS
- 27 CONNECTOR, ACCESSORY
- 28 CONNECTOR, FUEL PUMP/LEVEL SENSOR
- 29 CONNECTOR, TAILLIGHT
- 30 CONNECTOR, TAILLIGHT HARNESS
- 31 CONNECTOR, HANDLEBAR HARNESS
- 32 PDM
- 33 CONNECTOR, CHASSIS GROUND
- 34 CONNECTOR, DC REGULATOR
- 35 CONNECTOR, BATTERY CHARGE
- 36 CONNECTOR, STATOR
- 37 REGULATOR

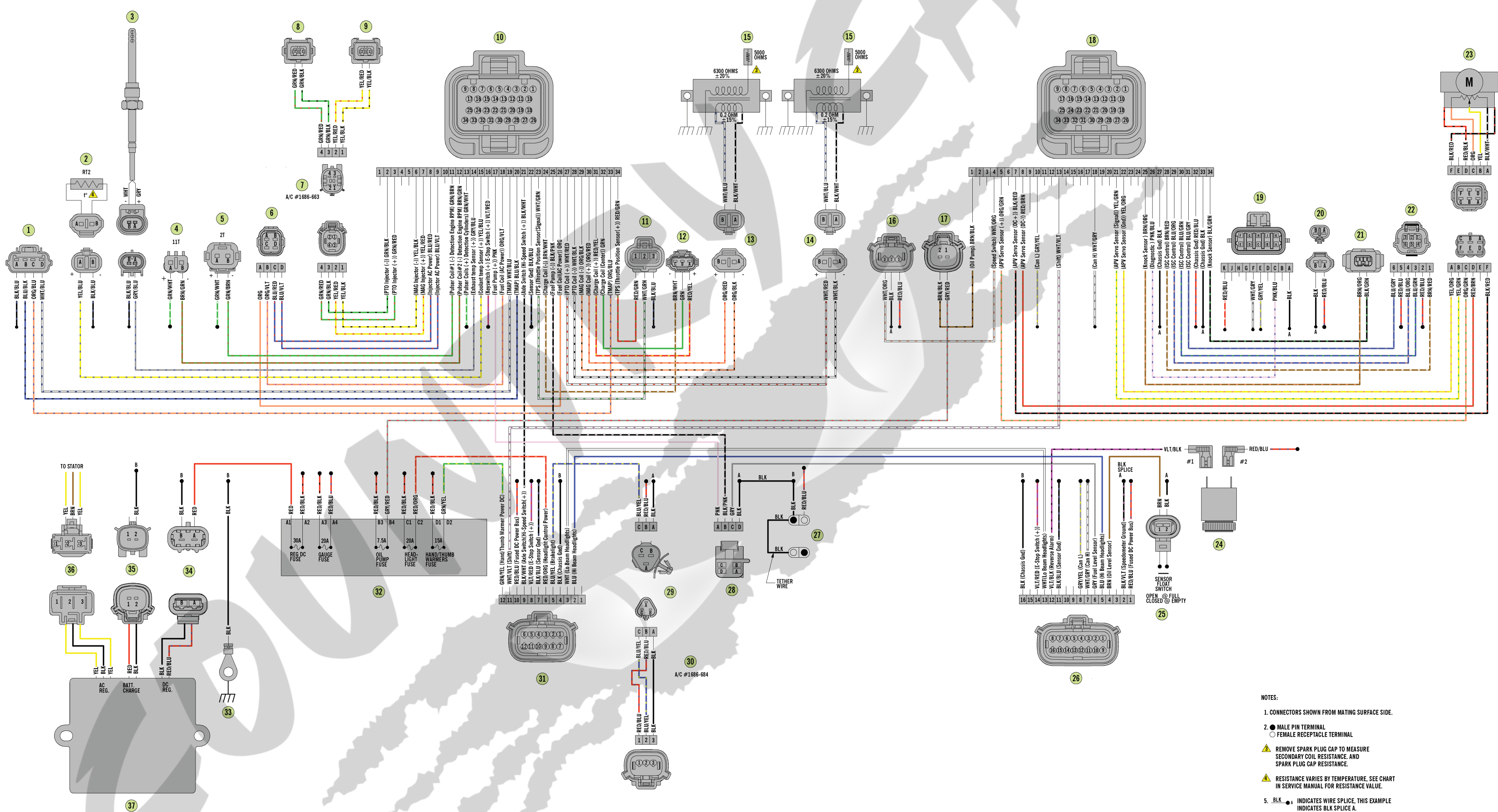

- NOTES:
1. CONNECTORS SHOWN FROM MATING SURFACE SIDE.
 2. ● MALE PIN TERMINAL
○ FEMALE RECEPTACLE TERMINAL
 3. REMOVE SPARK PLUG CAP TO MEASURE SECONDARY COIL RESISTANCE, AND SPARK PLUG CAP RESISTANCE.
 4. RESISTANCE VARIES BY TEMPERATURE, SEE CHART IN SERVICE MANUAL FOR RESISTANCE VALUE.
 5. BLK. ● INDICATES WIRE SPLICE, THIS EXAMPLE INDICATES BLK SPLICE A.

Main Harness (p/n 1686-723) M 8000/SP/SP LTD/Kincaid/McClure XF 8000 SP/CC SP/HC SP ZR 8000 SP/SP RR (p/n 1686-737) M 8000 HCR

- 1 SENSOR, THROTTLE POSITION
- 2 CONNECTOR, TIMING SENSOR #1
- 3 CONNECTOR, TIMING SENSOR #2
- 4 CONNECTOR, FUEL PUMP INJECTOR COILS
- 5 INJECTOR, P10
- 6 INJECTOR, MAG
- 7 CONNECTOR, ECU #1
- 8 CONNECTOR, CHARGE COIL
- 9 CONNECTOR, FUEL PUMP
- 10 CONNECTOR, ECU #2
- 11 CONNECTOR, DIAGNOSTIC
- 12 CONNECTOR, KNOCK SENSOR
- 13 SERVO MOTOR, APV
- 14 ALARM, REVERSE
- 15 CONNECTOR, ACCESSORY
- 16 PLUG, TETHER
- 17 SENSOR, OIL LEVEL
- 18 CONNECTOR, SPEED SENSOR
- 19 CONNECTOR, CONSOLE HARNESS
- 20 CONNECTOR, HANDLEBAR HARNESS
- 21 CONNECTOR, TAILLIGHT
- 22 PDM
- 23 FUSE
- 24 REGULATOR
- 25 CONNECTOR, MAGNETO
- 26 CONNECTOR, CHASSIS GROUND
- 27 SENSOR, EXHAUST TEMPERATURE
- 28 SENSOR, COOLANT TEMPERATURE
- 29 COIL, MAG. HV IGNITION #2
- 30 COIL, MAG. HV IGNITION #1
- 31 COIL, PTO. HV IGNITION #2
- 32 COIL, PTO. HV IGNITION #1

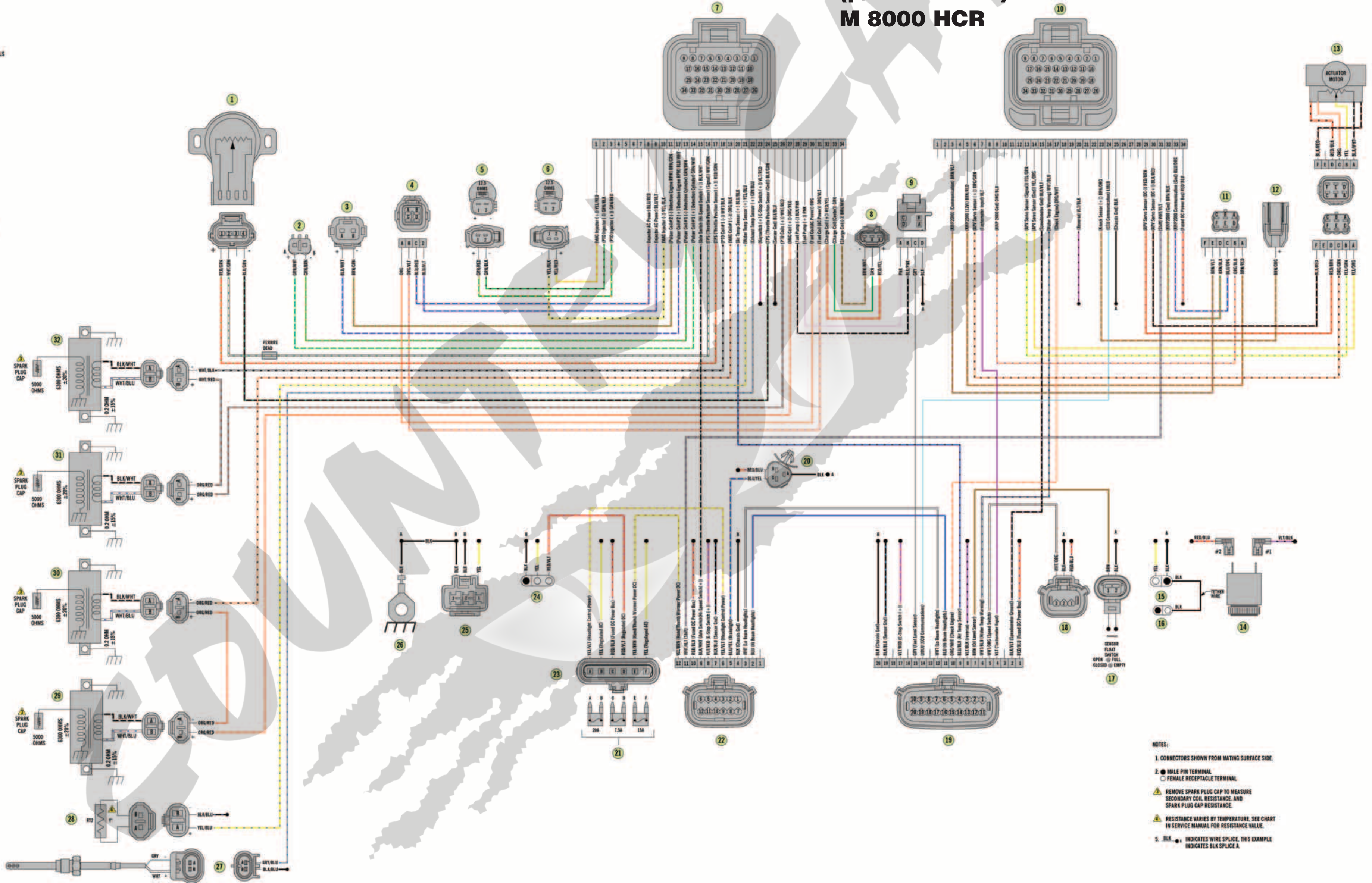

- NOTES:
- 1. CONNECTORS SHOWN FROM MATING SURFACE SIDE.
 - MALE PIN TERMINAL
 - FEMALE RECEPTACLE TERMINAL
 - ⚠ REMOVE SPARK PLUG CAP TO MEASURE SECONDARY COIL RESISTANCE, AND SPARK PLUG CAP RESISTANCE.
 - ⚠ RESISTANCE VARIES BY TEMPERATURE, SEE CHART IN SERVICE MANUAL FOR RESISTANCE VALUE.
 - 5. **BLK** INDICATES WIRE SPLICE, THIS EXAMPLE INDICATES BLK SPLICE A.

Hood Harness (p/n 1686-706) ZR 6000 ZR 6000 R CC M 6000 XF 6000

- 1 SPEEDOMETER
- 2 CONNECTOR, MAIN HARNESS
- 3 CONNECTOR, KEYSWITCH
- 4 OUTLET, ACCESSORY
- 5 HEADLIGHTS, B
- 6 HEADLIGHTS, A

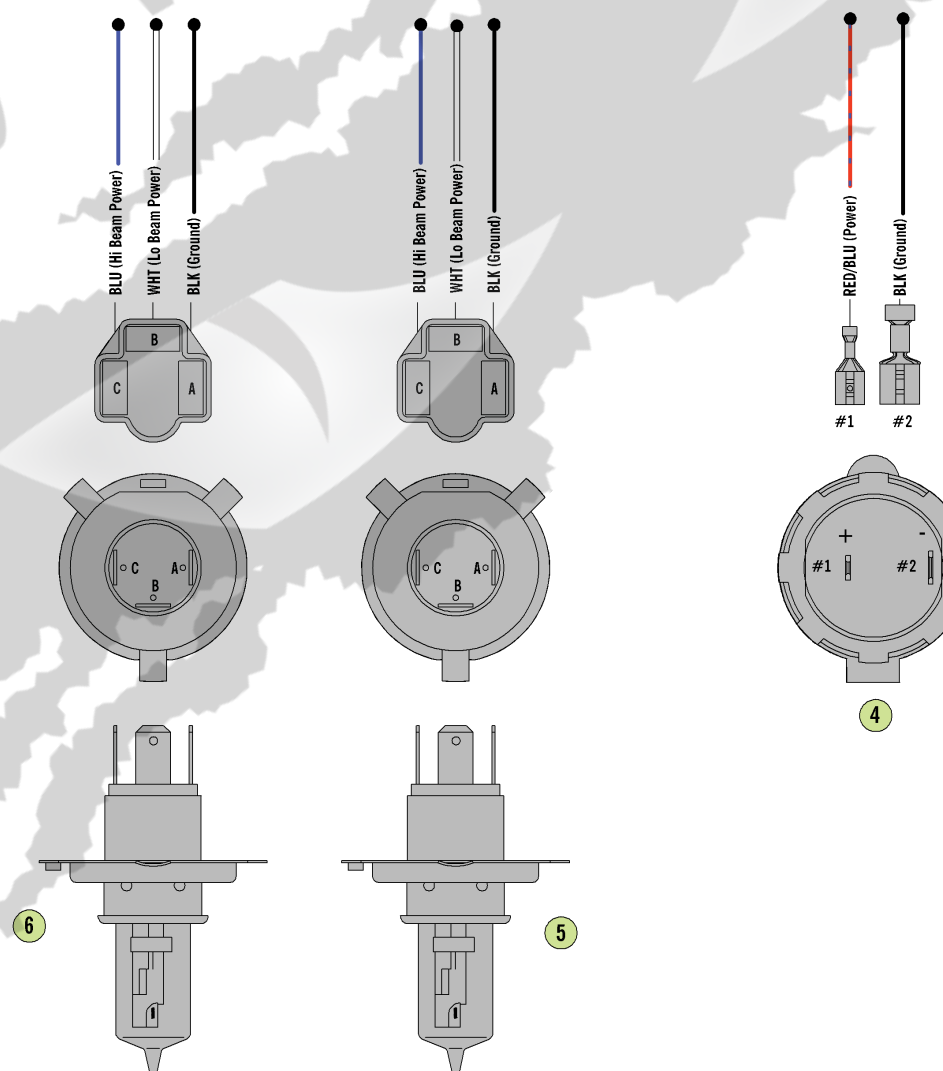
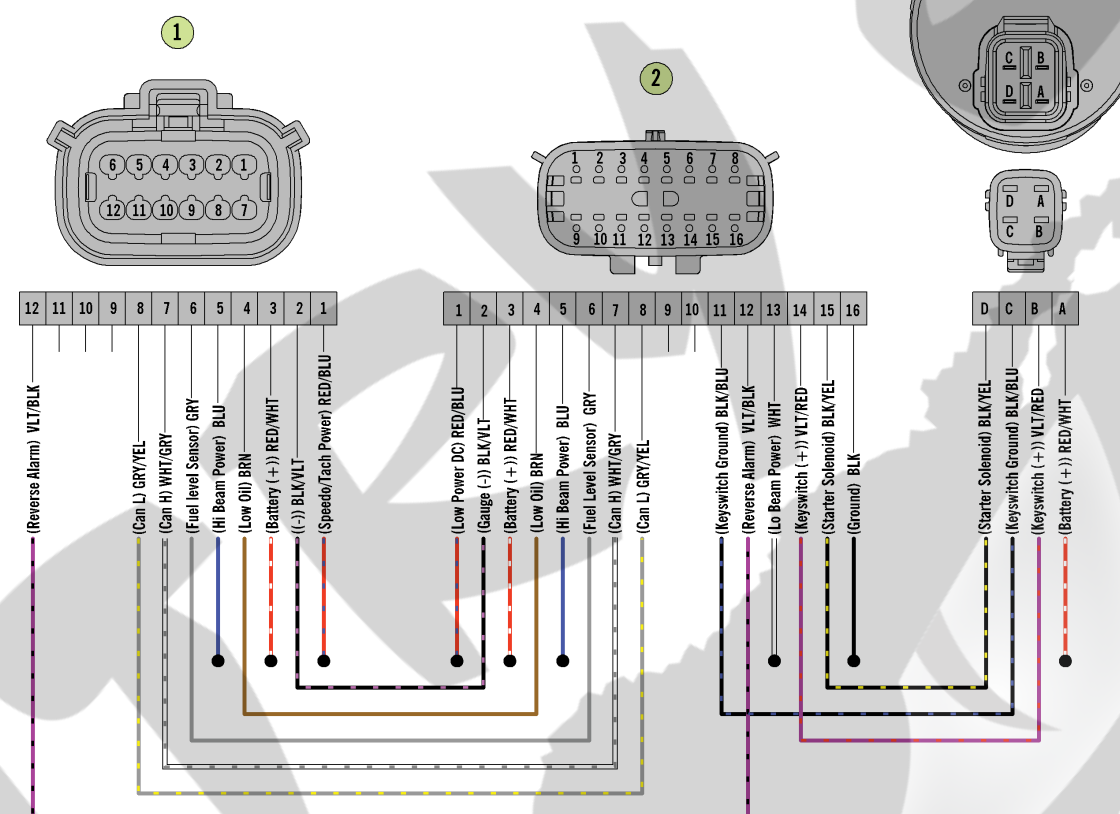
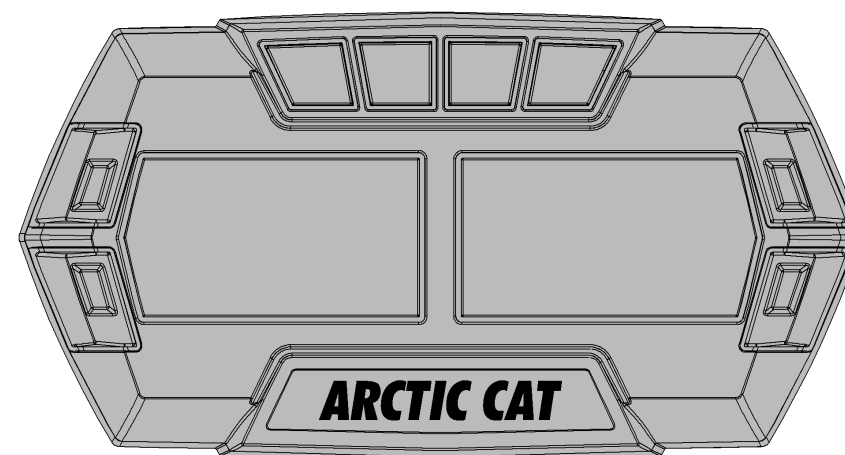

SWITCH FUNCTION	CIRCUIT DIAGRAM*			
	TERMINAL 'A'	TERMINAL 'B'	TERMINAL 'C'	TERMINAL 'D'
OFF		●	●	
ON	●			●
START				●

- NOTES:
- 1. CONNECTORS SHOWN FROM MATING SURFACE SIDE.
 - 2. **BLK** ● INDICATES WIRE SPLICE, THIS EXAMPLE INDICATES BLK SPLICE.

Hood Harness (p/n 1686-638) ZR 8000/XF 8000/M 8000

- 1 CONNECTOR, SPEEDOMETER
- 2 CONNECTOR, MAIN HARNESS #1
- 3 SWITCH, KEY
- 4 CONNECTOR, ACCESSORY 12V
- 5 SENSOR, AIR TEMPERATURE
- 6 HEADLIGHT, B
- 7 HEADLIGHT, A

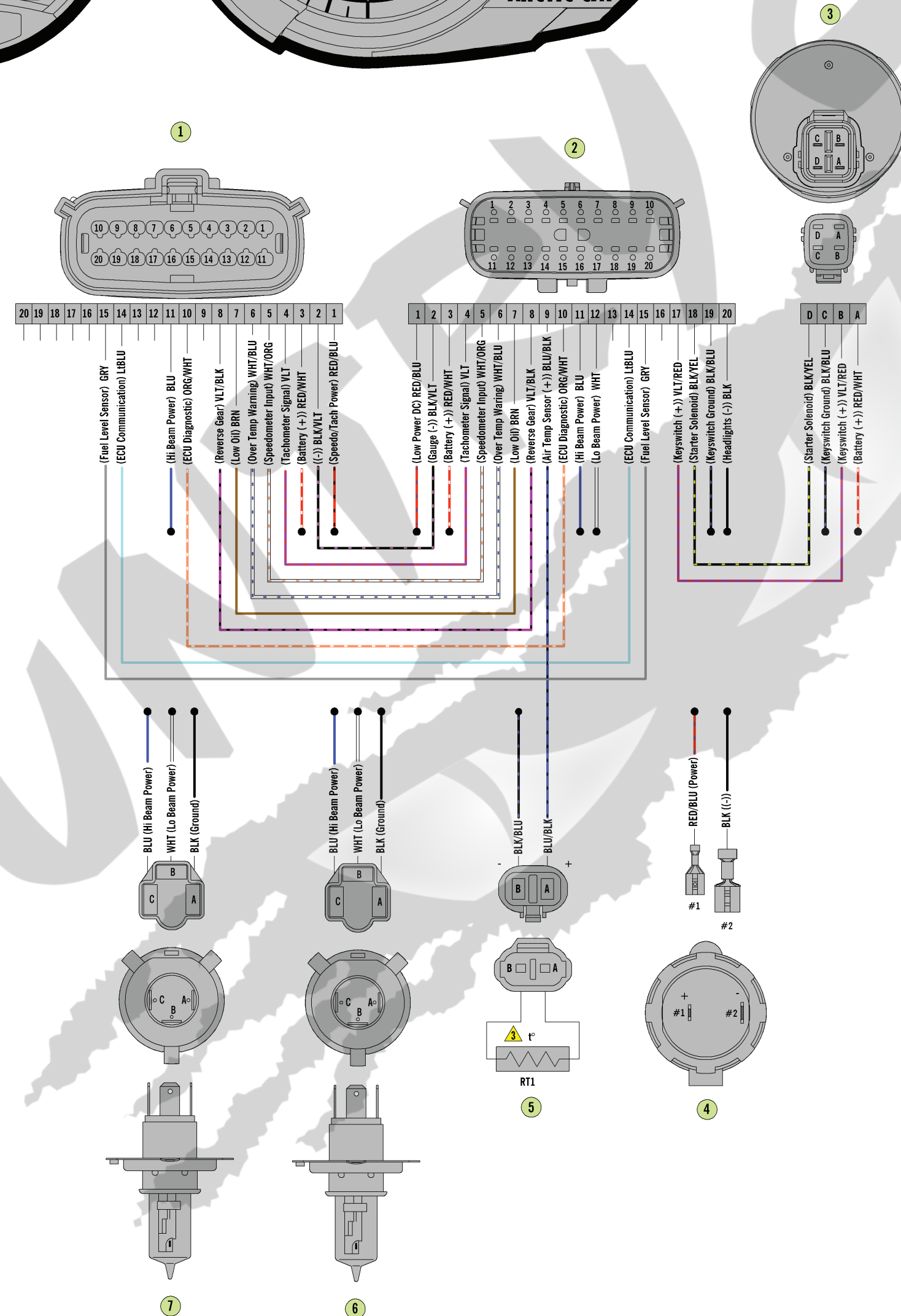
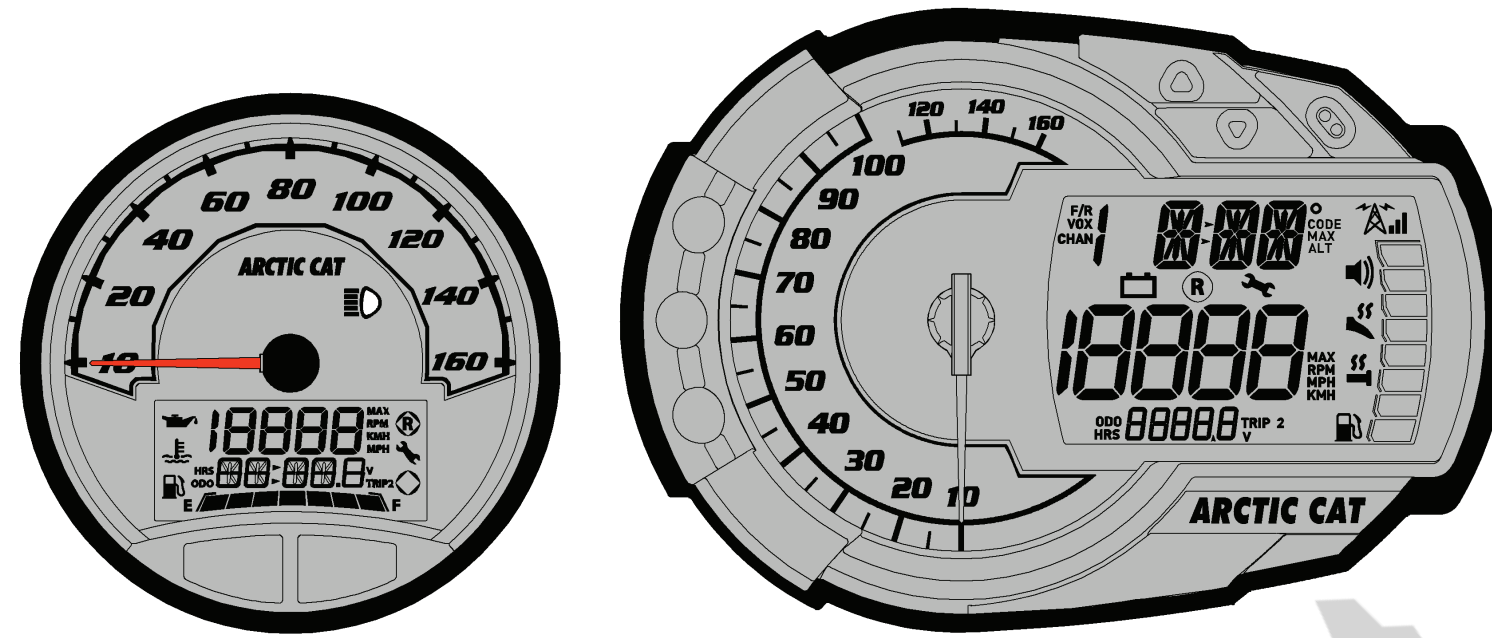

CIRCUIT DIAGRAM*				
SWITCH FUNCTION	TERMINAL 'A'	TERMINAL 'B'	TERMINAL 'C'	TERMINAL 'D'
OFF		●	●	
ON	●			
START				●

- NOTES:
- 1. CONNECTORS SHOWN FROM MATING SURFACE SIDE.
 - 2. **BLK** A INDICATES WIRE SPLICE, THIS EXAMPLE INDICATES BLK SPLICE A.
 - 3. RESISTANCE VARIES WITH TEMPERATURE. SEE CHART IN SERVICE MANUAL FOR RESISTANCE VALUE.

Console Harness (p/n 1686-748) ZR 4000/RR

- 1 CONNECTOR, SPEEDOMETER
- 2 CONNECTOR, MAIN HARNESS #1
- 3 CONNECTOR, KEYSWITCH
- 4 SOCKET, 12V ACCESSORY
- 5 SENSOR, AIR TEMPERATURE
- 6 HEADLIGHT B
- 7 HEADLIGHT A

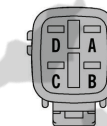
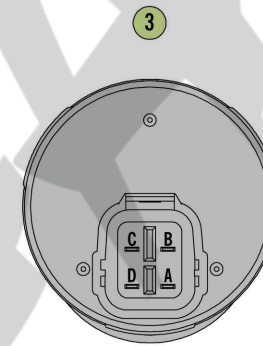
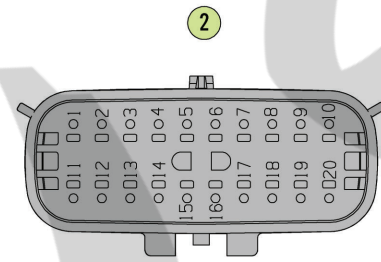
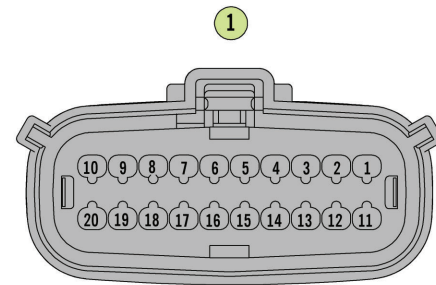
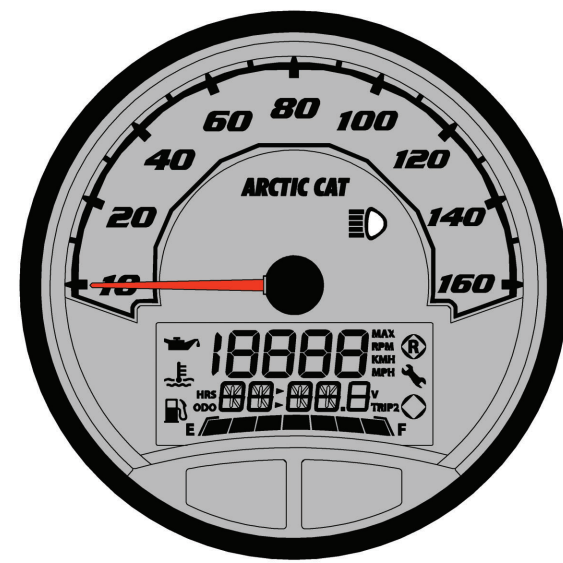

SWITCH FUNCTION	CIRCUIT DIAGRAM*			
	TERMINAL "A"	TERMINAL "B"	TERMINAL "C"	TERMINAL "D"
OFF		●	●	
ON				

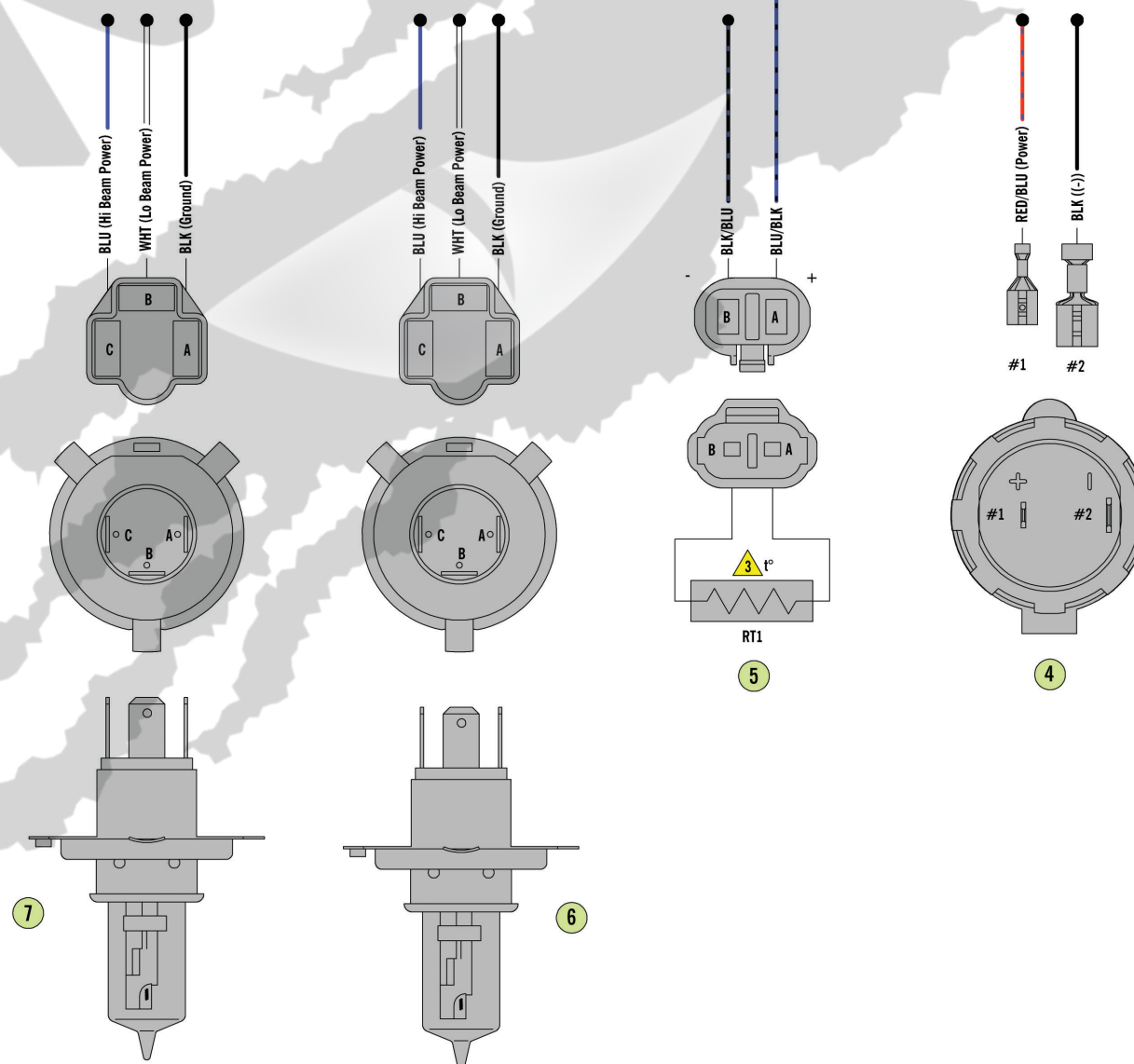
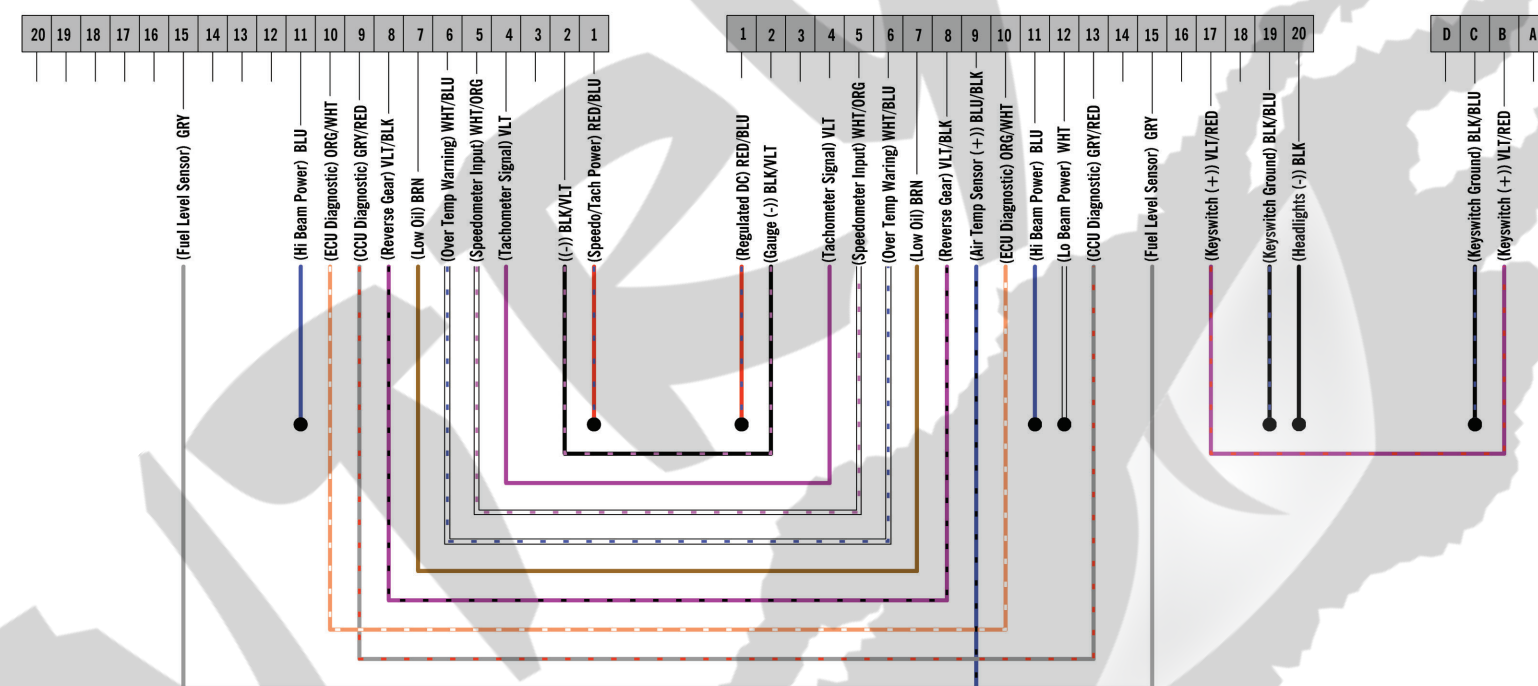

NOTES:

1. CONNECTORS SHOWN FROM MATING SURFACE SIDE, WHERE APPLICABLE.
2. BLK ● A INDICATES WIRE SPLICE, THIS EXAMPLE INDICATES BLK SPLICE A.
3. RESISTANCE VARIES BY TEMPERATURE, SEE CHART IN SERVICE MANUAL FOR RESISTANCE VALUE.

Handlebar Harness (p/n 1686-636) ZR 6000 (except SP RR) M 6000 SP XF 6000 XF 8000 ZR 8000 (except SP RR) M 8000 (except HCR) (p/n 1686-654) M 8000 HCR ZR 8000 SP RR ZR 6000 SP RR

- 1 CONNECTOR, HANDLEBAR
- 2 SWITCH, BRAKE
- 3 ELEMENT, LH HANDWARMER
- 4 CONNECTOR, HEADLIGHT CONTROL
- 5 SWITCH, HEADLIGHT
- 6 CONNECTOR, HANDWARMER/THUMBWARMER
- 7 SWITCH, HANDWARMER
- 8 SWITCH, THUMBWARMER
- 9 BULBS, SWITCH
- 10 ELEMENT, THUMBWARMER
- 11 ELEMENT, RH HANDWARMER
- 12 SWITCH, TETHER
- 13 SWITCH, EMERGENCY STOP
- 14 MICROSWITCH, RPS
- 15 SWITCH, SHIFT

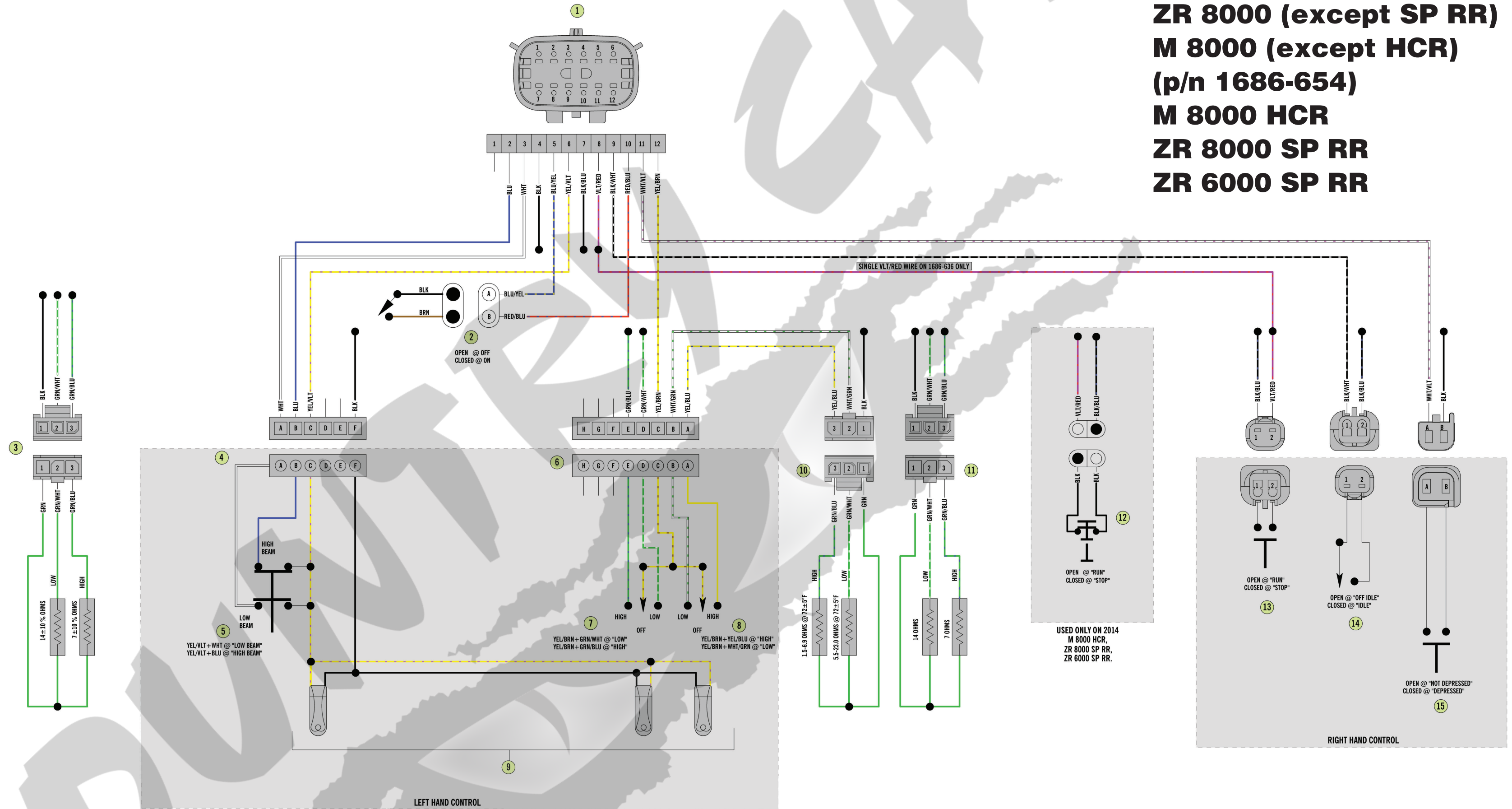

NOTES:

1. CONNECTORS SHOWN FROM MATING SURFACE SIDE, WHERE APPLICABLE.
2. ● MALE PIN TERMINAL
○ FEMALE RECEPTACLE TERMINAL
3. BLK ● A INDICATES WIRE SPLICE. THIS EXAMPLE INDICATES BLK SPLICE A.

Handlebar Harness (p/n 1686-574) ZR 4000/RR

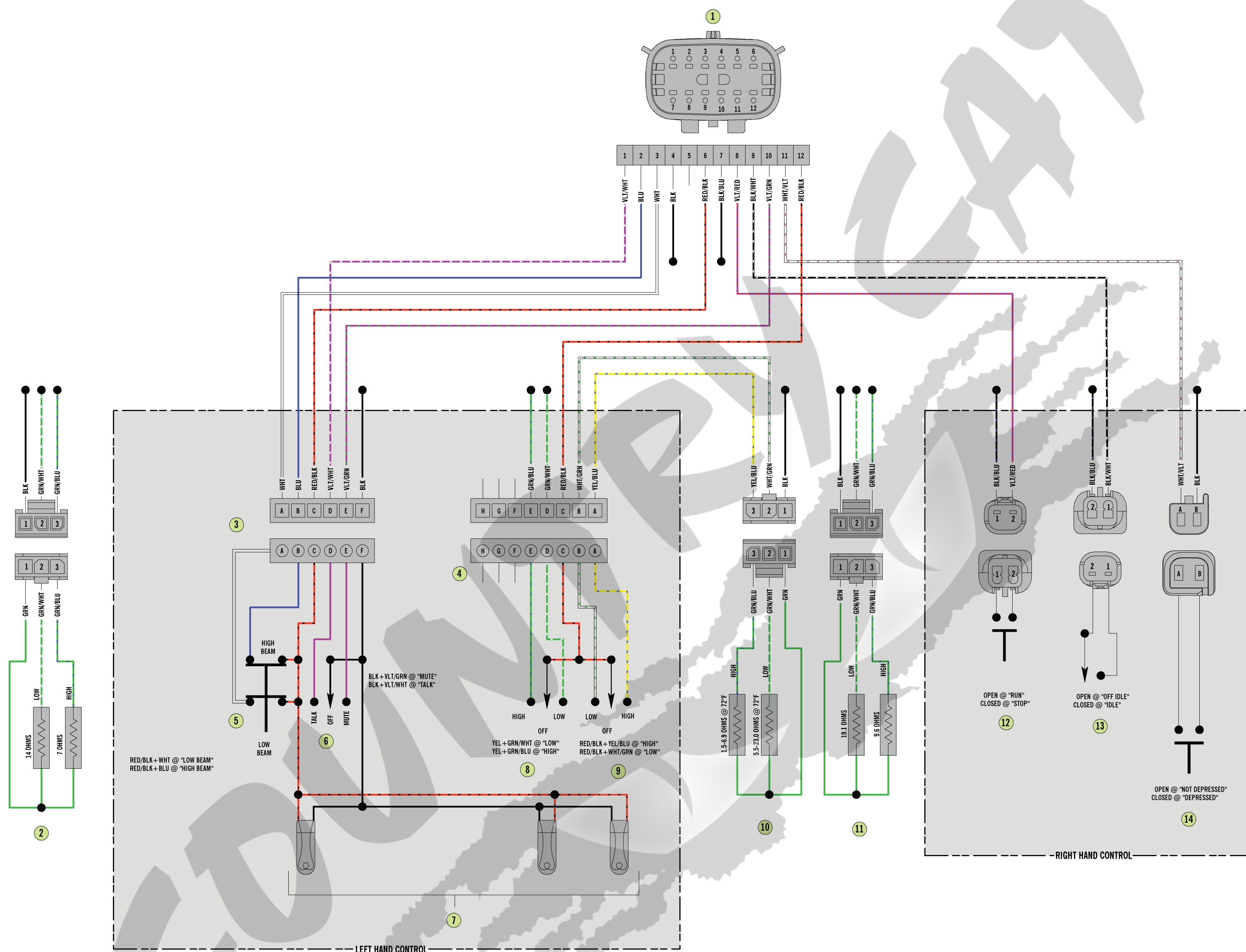

- NOTES:
- CONNECTORS SHOWN FROM MATING SURFACE SIDE, WHERE APPLICABLE.
 - BLK ● INDICATES WIRE SPLICE, THIS EXAMPLE INDICATES BLK SPLICE.

