

**EVINRUDE**<sup>®</sup>  
E-TEC<sup>®</sup>



## 2011 Service Manual

**40, 50, 60, 65, 75, 90 HP**





---

BRP US Inc.  
Technical Publications  
250 Sea Horse Drive  
Waukegan, Illinois 60085 United States



- † AMP, Superseal 1.5, Super Seal, Power Timer, and Pro-Crimper II are registered trademarks of Tyco International, Ltd.
- † Amphenol is a registered trademark of The Amphenol Corporation.
- † BEP is a registered trademark of Actuant Corporation.
- † Champion is a registered trademark of Federal-Mogul Corporation.
- † Deutsch is a registered trademark of The Deutsch Company.
- † Dexron is a registered trademark of The General Motors Corporation.
- † Fluke is a registered trademark of The Fluke Corporation
- † GE is a registered trademark of The General Electric Company.
- † GM is a registered trademark of The General Motors Corporation.
- † Loctite and Loctite are registered trademarks of The Henkel Group.
- † Lubriplate is a registered trademark of Fiske Brothers Refining Company.
- † NMEA is a registered trademark of the National Marine Electronics Association.
- † Oetiker is a registered trademark of Hans Oetiker AG Maschinen.
- † Packard is a registered trademark of Delphi Automotive Systems.
- † Permatex is a registered trademark of Permatex.
- † STP is a registered trademark of STP Products Company.
- † Snap-on is a registered trademark of Snap-on Technologies, Inc.

**The following trademarks are the property of BRP US Inc. or its affiliates:**

<i>Evinrude</i> <sup>®</sup>	<i>Twist Grip</i> <sup>™</sup>
<i>Johnson</i> <sup>®</sup>	<i>Nut Lock</i> <sup>™</sup>
<i>Evinrude</i> <sup>®</sup> <i>E-TEC</i> <sup>®</sup>	<i>Screw Lock</i> <sup>™</sup>
<i>FasTrak</i> <sup>™</sup>	<i>Ultra Lock</i> <sup>™</sup>
<i>S.A.F.E.</i> <sup>™</sup>	<i>Moly Lube</i> <sup>™</sup>
<i>SystemCheck</i> <sup>™</sup>	<i>Triple-Guard</i> <sup>®</sup> Grease
<i>I-Command</i> <sup>™</sup>	<i>DPL</i> <sup>™</sup> Lubricant
<i>Evinrude</i> <sup>®</sup> <i>ICON</i> <sup>™</sup>	<i>2+4</i> <sup>®</sup> Fuel Conditioner
<i>Evinrude</i> <sup>®</sup> / <i>Johnson</i> <sup>®</sup> <i>XD30</i> <sup>™</sup> Outboard Oil	<i>Carbon Guard</i> <sup>™</sup>
<i>Evinrude</i> <sup>®</sup> / <i>Johnson</i> <sup>®</sup> <i>XD50</i> <sup>™</sup> Outboard Oil	<i>HPF XR</i> <sup>™</sup> Gearcase Lubricant
<i>Evinrude</i> <sup>®</sup> / <i>Johnson</i> <sup>®</sup> <i>XD100</i> <sup>™</sup> Outboard Oil	<i>HPF PRO</i> <sup>™</sup> Gearcase Lubricant
<i>Gel-Seal II</i> <sup>™</sup>	

---

---

# SERVICE MANUAL CONTENTS

SECTION .....	PAGE
1 REFERENCE INFORMATION .....	3
2 ROUTINE SERVICE .....	15
3 ENGINE COVER SERVICE .....	49
4 ENGINE MANAGEMENT MODULE (EMM) .....	53
5 SYSTEM ANALYSIS .....	73
6 ELECTRICAL AND IGNITION .....	87
7 FUEL SYSTEM .....	121
8 OILING SYSTEM .....	153
9 COOLING SYSTEM .....	173
10 POWERHEAD .....	185
11 MIDSECTION .....	233
12 GEARCASE .....	289
GEARCASE SERVICE, 40 – 65 HP MODELS .....	296
GEARCASE SERVICE, 75 – 90 HP MODELS .....	318
13 TRIM AND TILT .....	343
14 MANUAL STARTER .....	361
SAFETY .....	S-1
INDEX .....	I-1
TROUBLE CHECK CHART .....	T-1
DIAGRAMS	

**IMPORTANT:** For complete outboard rigging and control installation information, refer to the **Predelivery and Installation Guide** included with the service manual set.

All special tools referenced in this manual can be found in the **Special Tools Guide**, P/N 5008526.



# REFERENCE INFORMATION

## TABLE OF CONTENTS

<b>SAFETY NOTICE</b> .....	<b>4</b>
<b>ABBREVIATIONS USED IN THIS MANUAL</b> .....	<b>6</b>
UNITS OF MEASUREMENT .....	6
LIST OF ABBREVIATIONS .....	6
<b>EMISSION-RELATED INSTALLATION INSTRUCTIONS</b> .....	<b>7</b>
MANUFACTURER'S RESPONSIBILITY .....	7
DEALER'S RESPONSIBILITY .....	7
OWNER'S RESPONSIBILITY .....	7
EPA EMISSION REGULATIONS .....	7
<b>MODEL DESIGNATION</b> .....	<b>8</b>
<b>MODELS COVERED IN THIS MANUAL</b> .....	<b>9</b>
<b>SERVICE SPECIFICATIONS</b> .....	<b>10</b>
<b>STANDARD TORQUE SPECIFICATIONS</b> .....	<b>14</b>
<b>PRODUCT REFERENCE AND ILLUSTRATIONS</b> .....	<b>14</b>

# SAFETY NOTICE

Before working on any part of the outboard, read the **SAFETY** section at the end of this manual.

This publication is written for qualified, factory-trained technicians who are already familiar with the use of *Evinrude/Johnson* Special Tools. The included information is not a substitute for work experience. It is an organized guide for reference, repair, and/or maintenance.

The following symbols and/or signal words may be used in this document:

 **DANGER**

Indicates a hazardous situation which, if not avoided, will result in death or serious injury.

 **WARNING**

Indicates a hazardous situation which, if not avoided, could result in death or serious injury

 **CAUTION**

Indicates a hazardous situation which, if not avoided, could result in minor or moderate personal injury.

**NOTICE** Indicates an instruction which, if not followed, could severely damage engine components or other property.

These safety alert signal words mean:

ATTENTION!  
BECOME ALERT!  
YOUR SAFETY IS INVOLVED!

**IMPORTANT:** Identifies information that controls correct assembly and operation of the product.

DO NOT perform any work until you have read and understood these instructions completely.

Torque wrench tightening specifications must strictly be adhered to.

Should removal of any locking fastener (lock tabs, locknuts, or patch screws) be required, always replace with a new one.

When replacement parts are required, use *Evinrude/Johnson Genuine Parts* or parts with equivalent characteristics, including type, strength and material. Use of substandard parts could result in injury or product malfunction.

Always wear EYE PROTECTION AND APPROPRIATE GLOVES when using power tools.

Unless otherwise specified, engine must be OFF when performing this work.

Always be aware of parts that can move, such as flywheels, propellers, etc.

Some components may be HOT. Always wait for engine to cool down before performing work.

If you use procedures or service tools that are not recommended in this manual, YOU ALONE must decide if your actions might injure people or damage the outboard.

This document may be translated into other languages. In the event of any discrepancy, the English version shall prevail.



 **DANGER**

Contact with a rotating propeller is likely to result in serious injury or death. Assure the engine and prop area is clear of people and objects before starting engine or operating boat. Do not allow anyone near a propeller, even when the engine is off. Blades can be sharp and the propeller can continue to turn even after the engine is off. Remove propeller before servicing and when running the outboard on a flushing device.

**DO NOT** run the engine indoors or without adequate ventilation or permit exhaust fumes to accumulate in confined areas. Engine exhaust contains carbon monoxide which, if inhaled, can cause serious brain damage or death.

 **WARNING**

Wear safety glasses to avoid personal injury, and set compressed air to less than 25 psi (172 kPa).

The motor cover and flywheel cover are machinery guards. Use caution when conducting tests on running outboards. **DO NOT** wear jewelry or loose clothing. Keep hair, hands, and clothing away from rotating parts.

During service, the outboard may drop unexpectedly. Avoid personal injury; always support the outboard's weight with a suitable hoist or the tilt support bracket during service.

To prevent accidental starting while servicing, disconnect the battery cables at the battery. Twist and remove all spark plug leads.

The electrical system presents a serious shock hazard. **DO NOT** handle primary or secondary ignition components while outboard is running or flywheel is turning.

Gasoline is extremely flammable and highly explosive under certain conditions. Use caution when working on any part of the fuel system.

Protect against hazardous fuel spray. Before starting any fuel system service, carefully relieve fuel system pressure.

Do not smoke, or allow open flames or sparks, or use electrical devices such as cellular phones in the vicinity of a fuel leak or while fueling.

Keep all electrical connections clean, tight, and insulated to prevent shorting or arcing and causing an explosion.

Always work in a well ventilated area.

Replace any locking fastener (locknut or patch screw) if its locking feature becomes weak. Definite resistance to tightening must be felt when reusing a locking fastener. If replacement is indicated, use only authorized replacement or equivalent.

## ABBREVIATIONS USED IN THIS MANUAL

### Units of Measurement

A	Amperes
amp-hr	Ampere hour
fl. oz.	fluid ounce
ft. lbs.	foot pounds
HP	horsepower
in.	inch
in. Hg	inches of mercury
in. lbs.	inch pounds
kPa	kilopascals
ml	milliliter
mm	millimeter
N·m	Newton meter
P/N	part number
psi	pounds per square inch
RPM	revolutions per minute
°C	degrees Celsius
°F	degrees Fahrenheit
ms	milliseconds
µs	microseconds
Ω	Ohms
V	Volts
VAC	Volts Alternating Current
VDC	Volts Direct Current

### List of Abbreviations

ABYC	American Boat & Yacht Council
ATDC	after top dead center
AT	air temperature sensor
BPS	barometric pressure sensor
BTDC	before top dead center
CCA	cold cranking amps
CFR	Code of Federal Regulations
CPS	crankshaft position sensor
EMM	Engine Management Module
EPA	Environmental Protection Agency
ICOMIA	International Council of Marine Industry Associations
ID	Inside dimension
MCA	marine cranking amps
MWS	modular wiring system
NMEA	National Marine Electronics Assoc.
ROM	read only memory
S.A.F.E.	speed adjusting failsafe electronics
SAC	start assist circuit
SAE	Society of Automotive Engineers
SYNC	synchronization
TDC	top dead center
TPS	throttle position sensor
USCG	United States Coast Guard
WOT	wide open throttle
WTS	water temperature sensor



# EMISSION-RELATED INSTALLATION INSTRUCTIONS

**Failing to follow these instructions when installing a certified engine in a vessel violates federal law (40 CFR 1068.105 (b)), subject to fines or other penalties as described in the Clean Air Act.**

Maintenance, replacement, or repair of the emission control devices and systems may be performed by any marine SI (spark ignition) engine repair establishment or individual.

## Manufacturer's Responsibility

Beginning with 1999 model year outboards, manufacturers of marine outboards must determine the exhaust emission levels for each outboard horsepower family and certify these outboards with the United States of America Environmental Protection Agency (EPA). An emissions control information label, showing emission levels and outboard specifications, must be placed on each outboard at the time of manufacture.

## Dealer's Responsibility

When performing service on all 1999 and more recent *Evinrude/Johnson* outboards that carry an emissions control information label, adjustments must be kept within published factory specifications.

Replacement or repair of any emission related component must be executed in a manner that maintains emission levels within the prescribed certification standards.

Dealers are not to modify the outboard in any manner that would alter the horsepower or allow emission levels to exceed their predetermined factory specifications.

Exceptions include manufacturer's prescribed changes, such as altitude adjustments, for example.

## Owner's Responsibility

The owner/operator is required to have outboard maintenance performed to maintain emission levels within prescribed certification standards.

The owner/operator is not to, and should not allow anyone to, modify the outboard in any manner that would alter the horsepower or allow emissions levels to exceed their predetermined factory specifications.

Tampering with the fuel system to change horsepower or modify emission levels beyond factory settings or specifications will void the product warranty.

## EPA Emission Regulations

All new 1999 and more recent *Evinrude/Johnson* outboards are certified to the EPA as conforming to the requirements of the regulations for the control of air pollution from new watercraft marine spark ignition outboards. This certification is contingent on certain adjustments being set to factory standards. For this reason, the factory procedure for servicing the product must be strictly followed and, whenever practical, returned to the original intent of the design. The responsibilities listed above are general and in no way a complete listing of the rules and regulations pertaining to the EPA requirements on exhaust emissions for marine products. For more detailed information on this subject, you may contact the following locations:

### VIA U.S. POSTAL SERVICE:

Office of Mobile Sources  
Engine Programs and Compliance Division  
Engine Compliance Programs Group (6403J)  
401 M St. NW  
Washington, DC 20460

### VIA EXPRESS or COURIER MAIL:

Office of Mobile Sources  
Engine Programs and Compliance Division  
Engine Compliance Programs Group (6403J)  
501 3rd St. NW  
Washington, DC 20001

### EPA INTERNET WEB SITE:

[www.epa.gov](http://www.epa.gov)

**REFERENCE INFORMATION**  
**MODEL DESIGNATION**

**MODEL DESIGNATION**

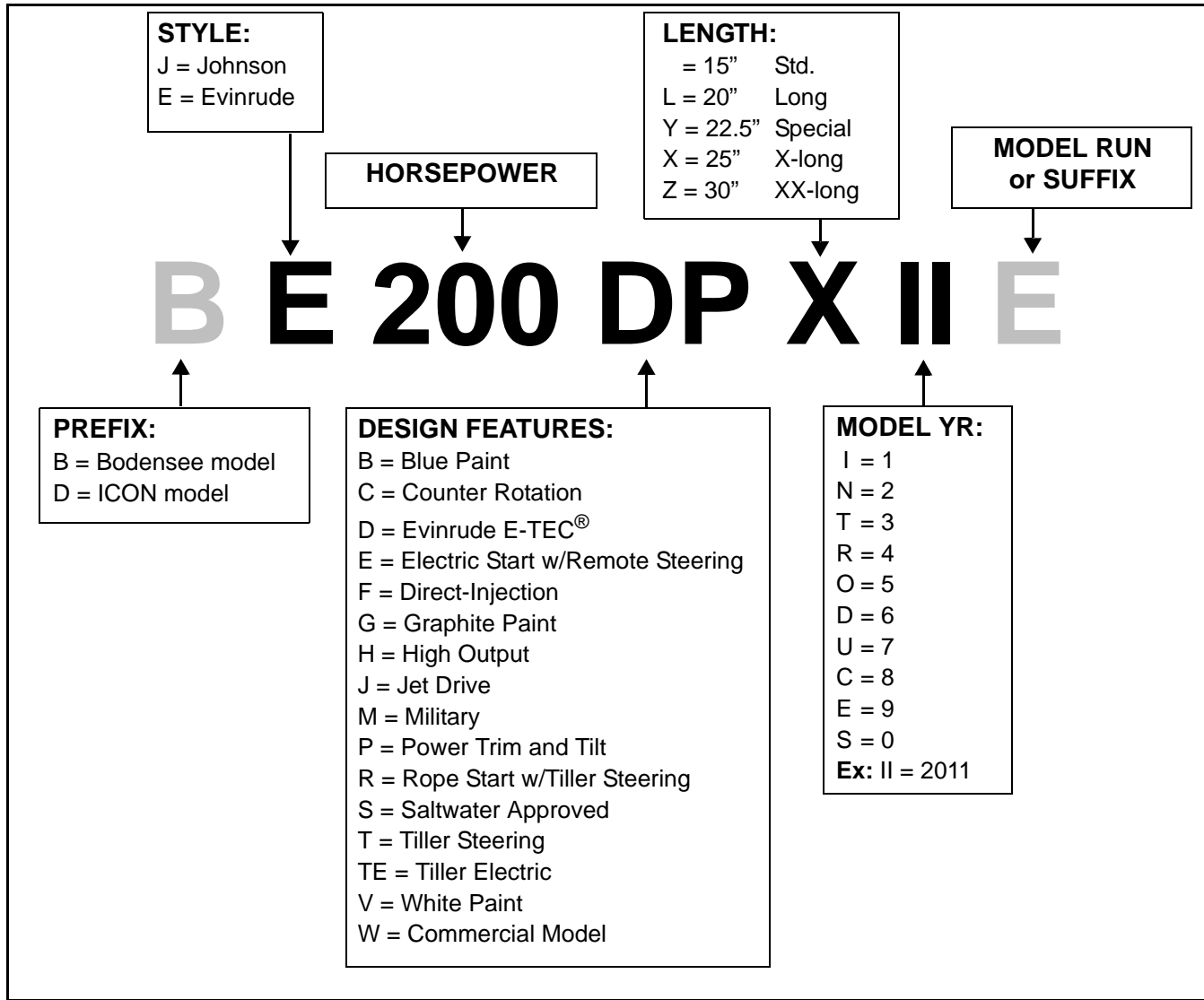

Model and serial numbers are located on the swivel bracket and on the powerhead.

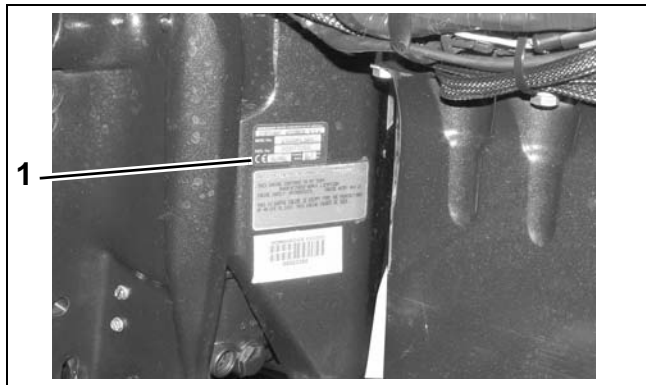

1. Model and serial number

002224

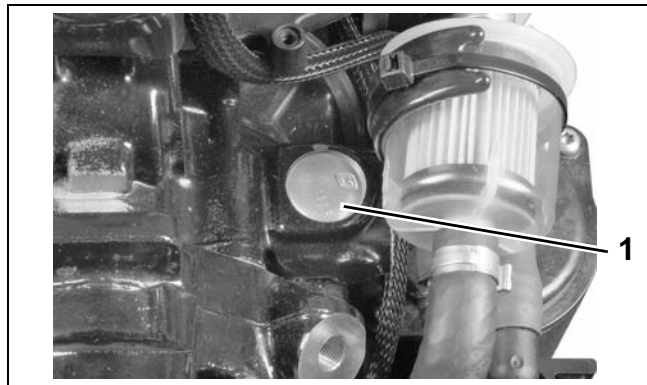

1. Serial number

002225



## MODELS COVERED IN THIS MANUAL

This manual covers service information on all 52.7 cubic inch (.86 L), 2-Cylinder; and 79 cubic inch (1.29 L), 3-Cylinder *Evinrude E-TEC* models.

<b>Model</b>	<b>Displacement</b>	<b>Gearcase</b>	<b>Height</b>	<b>Color</b>	<b>Description</b>
E40DRLIIS	.86 L, 52.7 ci	12:32 / 0.375 F	20"	Blue	Manual Tilt, Tiller Steering, Rope Start
E40DTLIIA	.86 L, 52.7 ci	12:32 / 0.375 F	20"	Blue	Power Tilt, Tiller Steering, Electric Start
E40DPLIIS	.86 L, 52.7 ci	12:32 / 0.375 F	20"	Blue	Power Tilt, Remote Steering, Electric Start
E40DSLIIA	.86 L, 52.7 ci	12:32 / 0.375 F	20"	White	Power Tilt, Remote Steering, Electric Start
E50DTLIIA	.86 L, 52.7 ci	12:32 / 0.375 F	20"	Blue	Power Tilt, Tiller Steering, Electric Start
E50DPLIIS	.86 L, 52.7 ci	12:32 / 0.375 F	20"	Blue	Power Tilt, Remote Steering, Electric Start
E50DSLIIA	.86 L, 52.7 ci	12:32 / 0.375 F	20"	White	Power Tilt, Remote Steering, Electric Start
E60DTLIIA	.86 L, 52.7 ci	12:32 / 0.375 F	20"	Blue	Power Tilt, Tiller Steering, Electric Start
E60DPLIIS	.86 L, 52.7 ci	12:32 / 0.375 F	20"	Blue	Power Tilt, Remote Steering, Electric Start
E60DSLIIA	.86 L, 52.7 ci	12:32 / 0.375 F	20"	White	Power Tilt, Remote Steering, Electric Start
E65WDRLIIA	.86 L, 52.7 ci	12:32 / 0.375 F	20"	Blue	Manual Tilt, Tiller Steering, Rope Start
E65WDRYIIA	.86 L, 52.7 ci	12:32 / 0.375 F	22.5"	Blue	Manual Tilt, Tiller Steering, Rope Start
E75DPLIIS	1.29 L, 79.0 ci	13:26 / 0.50 S	20"	Blue	Power Tilt, Steel Steering Arm
E75DSLIIA	1.29 L, 79.0 ci	13:26 / 0.50 S	20"	White	Power Tilt, Stainless Steering Arm
E90DPLIIS	1.29 L, 79.0 ci	13:26 / 0.50 S	20"	Blue	Power Tilt, Steel Steering Arm
E90DSLIID	1.29 L, 79.0 ci	13:26 / 0.50 S	20"	White	Power Tilt, Stainless Steering Arm
E90DPXIIS	1.29 L, 79.0 ci	12:27 / 0.444 O	25"	White	Power Tilt, Stainless Steering Arm
E90WDELIIA	1.29 L, 79.0 ci	13:26 / 0.50 S	20"	Blue	Manual Tilt, Steel Steering Arm, Commercial Model
E90WDEXIIA	1.29 L, 79.0 ci	12:27 / 0.444 O	25"	White	Manual Tilt, Steel Steering Arm, Commercial Model

**REFERENCE INFORMATION**  
**SERVICE SPECIFICATIONS**

**SERVICE SPECIFICATIONS**

40 – 65 HP E-TEC Models		
<b>ENGINE</b>	Full Throttle Operating Range RPM	40 HP – 5000 to 6000 RPM 50 HP – 5500 to 6000 RPM 60 HP – 5500 to 6000 RPM 65 HP – 5500 to 6000 RPM
	Power	40 HP (30 kw) @ 5500 RPM 50 HP (37 kw) @ 5750 RPM 60 HP (45 kw) @ 5750 RPM 65 HP (45 kw) @ 5750 RPM
	Idle RPM in Gear	800 ± 50 <i>EMM</i> Controlled
	Idle RPM in Neutral	750 ± 50 <i>EMM</i> Controlled
	Test Propeller	P/N 382861
	Weight (may vary depending on model)	<b>(RL) Models:</b> 232 lbs. (105 kg) <b>(PL) Models:</b> 240 lbs. (109 kg)
	Lubrication	<i>Evinrude/Johnson XD100, XD50, XD30</i> ; or NMMA TC-W3 certified
	Engine Type	In-line, 2 Cylinder, Two-Cycle
	Displacement	52.7 cu. in. (864 cc)
	Bore	3.601 in. (91.47 mm)
	Stroke	2.588 in. (65.74 mm)
	Standard Bore	3.6005 to 3.6015 in. (91.45 to 91.48 mm) To bore oversize, add piston oversize dimension to standard bore
	Top Crankshaft Journal	2.1870 to 2.1875 in. (55.55 to 55.56 mm)
	Center Crankshaft Journal	2.1870 to 2.1875 in. (55.55 to 55.56 mm)
	Bottom Crankshaft Journal	1.5747 to 1.5752 in. (40.0 to 40.01 mm)
Rod Crankpin	1.3757 to 1.3762 in. (34.94 to 34.96 mm)	
Piston Ring End Gap, Both	0.011 to 0.023 in. (0.28 to 0.58 mm)	
<b>FUEL</b>	Fuel/Oil Control	<i>EMM</i> Controlled
	Starting Enrichment	<i>EMM</i> Controlled
	Minimum (High) Fuel Pressure	24 to 28 psi (165 to 193 kPa)
	Minimum Fuel Lift Pump Pressure	3 psi (21 kPa)
	Maximum Fuel Inlet Vacuum	4 in. Hg.
	Minimum Octane	87 AKI (R+M)/2 or 90 RON
	Additives	2+4 <sup>®</sup> <i>Fuel Conditioner, Fuel System Cleaner</i> Use of other additives may result in engine damage. See <b>Fuel Requirements</b> on p. 131 for additional information

<b>40 – 65 HP E-TEC Models</b>		
<b>ELECTRICAL</b>	Minimum Battery Requirements	640 CCA (800 MCA) <b>or</b> 800 CCA (1000 MCA) below 32° F (0° C)
	Alternator	25-Amp fully regulated. Refer to <b>Predelivery and Installation Guide</b> for multiple battery applications.
	Tachometer Setting	6 pulse (12 pole)
	Engine Fuse	P/N 967545 – 10 A
<b>COOLING</b>	Thermostat	143°F (62°C)
	Maximum Temperature	212°F (100°C)
	Water pressure	12 to 14 psi @ 5000 RPM
<b>IGNITION</b>	Type	Capacitor Discharge
	Firing Order	1-2
	Ignition Timing	<i>EMM</i> Controlled
	RPM Limit in Gear	6250
	RPM Limit in Neutral	1800
	Crankshaft Position Sensor Air Gap	Fixed
	Spark Plug	Refer to Emission Control Information Label <i>Champion</i> <sup>†</sup> QC10WEP @ 0.028 ± .003 in. (0.71 mm)
<b>GEARCASE</b>	Gear Ratio	12:32 (.375)
	Lubricant	<i>HPF XR Gearcase Lube</i> <i>HPF Pro</i> in high performance or commercial applications
	Capacity	22 fl. oz. (650 ml)
	Shift Rod Height	<b>20 in. (L) Models:</b> 21.38 (543 mm) ± one-half turn
	Shift Cable Stroke	1.125 to 1.330 in. (28.6 to 33.8 mm) measured between NEUTRAL and FORWARD
<b>POWER TRIM/TILT</b>	Lubrication	<i>Evinrude/Johnson</i> Biodegradable TNT Fluid
	Fluid Capacity	15.2 fl. oz. (450 ml)
	Trim Range	0° to 15°
	Tilt Range	16° to 65°

**REFERENCE INFORMATION**  
**SERVICE SPECIFICATIONS**

<b>75 – 90 HP E-TEC Models</b>		
<b>ENGINE</b>	Full Throttle Operating Range RPM	4500 to 5500 RPM
	Power	75 HP (56 kw) @ 5000 RPM 90 HP (67.1 kw) @ 5000 RPM
	Idle RPM in Gear	700 ± 50 <i>EMM</i> Controlled
	Idle RPM in Neutral	600 ± 50 <i>EMM</i> Controlled
	Test Propeller	<b>(L) Models:</b> P/N 386246 <b>(X) Models:</b> P/N 387388
	Weight (may vary depending on model)	<b>(L) Models:</b> 320 lbs. (145 kg) <b>(X) Models:</b> 335 lbs. (152 kg)
	Lubrication	<i>Evinrude/Johnson XD100, XD50, XD30</i> ; or NMMA TC-W3 certified
	Engine Type	In-line, 3 Cylinder, Two-Cycle
	Displacement	79.1 cu. in. (1296 cc)
	Bore	3.601 in. (91.47 mm)
	Stroke	2.588 in. (65.74 mm)
	Standard Bore	3.6005 to 3.6015 in. (91.45 to 91.48 mm) To bore oversize, add piston oversize dimension to standard bore
	Top Crankshaft Journal	2.1870 to 2.1875 in. (55.55 to 55.56 mm)
	Center Crankshaft Journals	2.1870 to 2.1875 in. (55.55 to 55.56 mm)
	Bottom Crankshaft Journal	1.5747 to 1.5752 in. (40.0 to 40.01 mm)
	Rod Crankpin	1.3757 to 1.3762 in. (34.94 to 34.96 mm)
	Piston Ring End Gap, Both	0.011 to 0.023 in. (0.28 to 0.58 mm)
<b>FUEL</b>	Fuel/Oil Control	<i>EMM</i> Controlled
	Starting Enrichment	<i>EMM</i> Controlled
	Minimum (High) Fuel Pressure	24 to 28 psi (165 to 193 kPa)
	Minimum Fuel Lift Pump Pressure	3 psi (21 kPa)
	Maximum Fuel Inlet Vacuum	4 in. Hg.
	Minimum Octane	87 AKI (R+M)/2 or 90 RON
	Additives	<i>2+4® Fuel Conditioner, Fuel System Cleaner</i> Use of other additives may result in engine damage. See <b>Fuel Requirements</b> on p. 131 for additional information

<b>75 – 90 HP E-TEC Models</b>		
<b>ELECTRICAL</b>	Minimum Battery Requirements	640 CCA (800 MCA) or 800 CCA (1000 MCA) below 32° F (0° C)
	Alternator	25-Amp fully regulated. Refer to <b>Predelivery and Installation Guide</b> for multiple battery applications.
	Tachometer Setting	6 pulse (12 pole)
	Engine Fuse	P/N 967545 – 10 A
<b>COOLING</b>	Maximum Temperature	212°F (100°C)
	Thermostat	143°F (62°C)
	Water pressure	19 to 21 psi @ 5000 RPM
<b>IGNITION</b>	Type	Capacitor Discharge
	Firing Order	1-2-3
	Ignition Timing	<i>EMM</i> Controlled
	RPM Limit in Gear	6250
	RPM Limit in Neutral	1800
	Crankshaft Position Sensor Air Gap	Fixed
	Spark Plug	Refer to Emission Control Information Label <i>Champion</i> <sup>†</sup> QC10WEP @ 0.028 ±.003 in. (0.71 mm)
<b>GEARCASE</b>	Gear Ratio	<b>20 in. (L) Models:</b> 13:26 (.500)      2:1 <b>25 in. (X) Models:</b> 12:27 (.444)      2.25:1
	Lubricant	<i>HPF XR Gearcase Lube</i>
	Capacity	<b>20 in. (L) Models:</b> 31.6 fl. oz. (935 ml) <b>25 in. (X) Models:</b> 32.8 fl. oz. (970 ml)
	Shift Rod Height	<b>20 in. (L) Models:</b> 21.25 (539.75 mm) ± one-half turn <b>25 in. (X) Models:</b> 26.25 (666.75 mm) ± one-half turn
	Shift Cable Stroke	1.125 to 1.330 in. (28.6 to 33.8 mm) measured between NEUTRAL and FORWARD
<b>POWER TRIM/TILT</b>	Lubrication	<b>Single Piston System</b> — <i>Evinrude/Johnson</i> Biodegradable TNT Fluid
	Fluid Capacity	21 fl. oz. (620 ml)
	Trim Range	0° to 15°
	Tilt Range	16° to 65°

**REFERENCE INFORMATION**  
**STANDARD TORQUE SPECIFICATIONS**

**STANDARD TORQUE SPECIFICATIONS**

Size	In. Lbs.	Ft. Lbs.	N·m
No. 6	7–10	0.58–0.83	0.8–1.1
No. 8	15–22	1.25–1.83	1.7–2.5
No. 10	24–36	2–3	2.7–4.0
No. 12	36–48	3–4	4.0–5.4
1/4 in.	60–84	5–7	7–9.5
5/16 in.	120–144	10–12	13.5–16.5
3/8 in.	216–240	18–20	24.5–27
7/16 in.	336–384	28–32	38–43.5
M3	15–22	1.25–1.83	1.7–2.5
M4	24–35	2–2.9	2.7–4.0
M5	35–60	2.9–5	4.0–6.8
M6	84–106	7–8.8	9.5–12
M8	177–204	14.7–17	20–23
M10	310–336	25.8–28	35–38

**IMPORTANT:** These values apply only when a specific torque for a specific fastener is not listed in the appropriate section. When tightening two or more screws on the same part, **DO NOT** tighten screws completely, one at a time.

**⚠ WARNING**

Torque wrench tightening specifications must be strictly adhered to. Replace any locking fastener (locknut or patch screw) if its locking feature becomes weak. Definite resistance to turning must be felt when reusing a locking fastener.

If replacement is specified or required because the locking fastener has become weak, use only authorized *Evinrude/Johnson Genuine Parts*.

**PRODUCT REFERENCE AND ILLUSTRATIONS**

*BRP US Inc.* reserves the right to make changes at any time, without notice, in specifications and models and also to discontinue models. The right is also reserved to change any specifications or parts, at any time, without incurring any obligation to equip same on models manufactured prior to date of such change. Specifications used are based on the latest product information available at the time of publication.

The continuing accuracy of this manual cannot be guaranteed.

All photographs and illustrations used in this manual may not depict actual models or equipment, but are intended as representative views for reference only.

Certain features or systems discussed in this manual might not be found on all models in all marketing areas.

All service technicians must be familiar with nautical orientation. This manual often identifies parts and procedures using these terms.

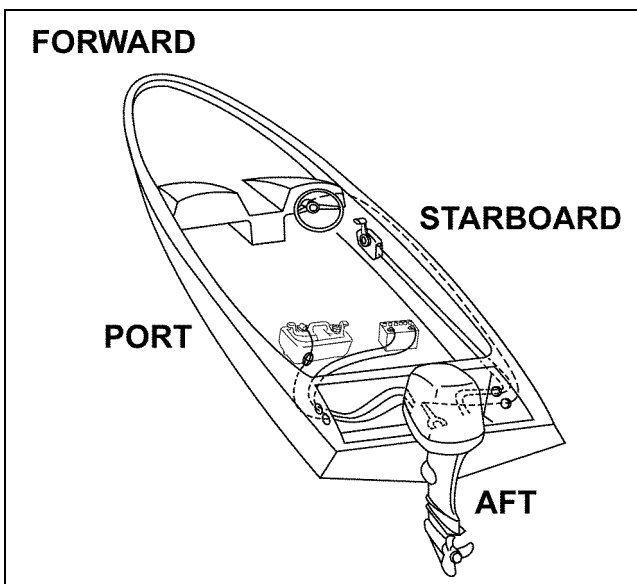

Nautical Orientation

006411

# ROUTINE SERVICE

## TABLE OF CONTENTS

INSPECTION AND MAINTENANCE SCHEDULE .....	16
LIFTING THE OUTBOARD .....	17
OUTBOARD RIGGING CONNECTIONS .....	17
CONTROL CABLE INSTALLATION .....	19
SYSTEMCHECK HARNESS CONNECTIONS .....	20
I-COMMAND NETWORK CONNECTIONS .....	21
WATER PRESSURE GAUGE .....	23
BATTERY AND BATTERY CONNECTIONS .....	24
OETIKER CLAMP SERVICING .....	25
ADJUSTMENTS .....	27
STEERING FRICTION ADJUSTMENT .....	27
THROTTLE FRICTION ADJUSTMENT .....	27
TILT LIMIT SWITCH ADJUSTMENT (75 – 90 HP) .....	28
TRIM SENDING UNIT ADJUSTMENT (40 – 60 HP) .....	29
TRIM SENDING UNIT ADJUSTMENT (75 – 90 HP) .....	30
TRIM TAB ADJUSTMENT .....	31
DUAL-OUTBOARD ALIGNMENT .....	32
OPERATIONAL CHECKS .....	33
COOLING SYSTEM .....	34
ENGINE FLUSHING .....	35
RUNNING THE OUTBOARD USING A HOSE AND FLUSHING ADAPTER .....	36
LUBRICATION .....	37
STEERING SYSTEM .....	37
TILLER HANDLE .....	37
SWIVEL BRACKET AND TRAILERING BRACKET .....	38
TILT TUBE .....	38
THROTTLE AND SHIFT LINKAGE .....	38
PROPELLER SHAFT .....	39
GEARCASE LUBRICANT .....	39
TRIM AND TILT .....	41
SPARK PLUGS .....	42
INDEXING .....	42
FUEL AND OIL SYSTEMS .....	43
FUEL FILTER .....	43
OIL FILTERS AND OIL RESERVOIR .....	43
AIR SILENCER .....	43
HOSES AND CONNECTIONS .....	43
ANTI-CORROSION PROTECTION .....	44
STORAGE .....	45
FUEL SYSTEM TREATMENT .....	45
INTERNAL ENGINE TREATMENT .....	45
ADDITIONAL RECOMMENDATIONS .....	46
PRE-SEASON SERVICE .....	46
SUBMERGED ENGINES .....	47



**ROUTINE SERVICE**  
INSPECTION AND MAINTENANCE SCHEDULE

# INSPECTION AND MAINTENANCE SCHEDULE

Routine inspection and maintenance is necessary to prolong outboard life. The following chart provides guidelines for inspection and maintenance to be performed by an authorized Dealer.

**IMPORTANT:** Outboards used in rental, commercial, or other high hour applications require more frequent inspections and maintenance. Adjust schedule for operating and environmental conditions.

Description	Engine Care Product	Routine Inspection	Every 300 hours or every three years <sup>(1)</sup>
Engine Monitor self-test and warning horn, check		✓	
Emergency stop circuit and lanyard, check operation		✓	
Controls, steering and tilting; check operation		✓	
Engine mounting hardware, re-tighten (40 ft. lbs.)		✓	
Fasteners, tighten any loosened components		✓	
Water intake screens, check condition		✓	
Cooling system; check water pump indicator / water pressure		✓	
Anticorrosion anodes, check condition		✓	
Gearcase, check condition		✓	
Propeller, check condition		✓	
Fuel and oil systems, inspect and repair leaks <sup>(2)</sup>		✓	
Check battery connections and condition		✓	
Access <i>EMM</i> information, resolve any service codes			✓
Electrical and ignition wires, inspect for wear or chafing			✓
Fuel filter, replace			✓
Oil filters, replace			✓
Gearcase lubricant, replace	A		✓
Spark plugs, inspect or replace <sup>(2)</sup>			✓
Thermostats, inspect and check operation <sup>(2)</sup>			✓
Grease fittings, lubricate <sup>(3)</sup>	C		✓
Power trim/tilt and fluid level, inspect	B		✓
Propeller shaft splines, inspect and lubricate <sup>(3)</sup>	C		✓
Starter pinion shaft, inspect and lubricate <sup>(3)</sup>	D		✓
Control cables, inspect and adjust			✓
Steering cable, inspect and lubricate	C		✓
Water pump, inspect / replace (more often if water pressure loss or overheating occurs)			✓

(1) Average recreational use. Commercial use, heavy use, or use in salt or polluted water requires more frequent inspection and maintenance.

(2) Emission-related component

(3) Annually in salt water applications

- A *HPF Pro* Gearcase Lubricant
- B Power Trim/Tilt Fluid (Three ram hydraulic systems)  
Biodegradable TNT Fluid (Single ram hydraulic systems)
- C *Triple-Guard* Grease
- D Starter Bendix Lube Only

# LIFTING THE OUTBOARD

**⚠ WARNING**

To avoid personal injury, make sure the lifting capacity of the hoist is at least twice the weight of the outboard.

**DO NOT** allow the lift hook or chain from the hoist to come in contact with any part of the engine during lifting.

Use correct Lifting Fixture to lift outboard:

Model	Lifting Fixture
40–90 HP	P/N 396748 with 1 1/8 in. screws

With recoil starter removed, Place lifting tool on flywheel and seat the three screws completely. Refer to **RECOIL STARTER REMOVAL** on p. 363.

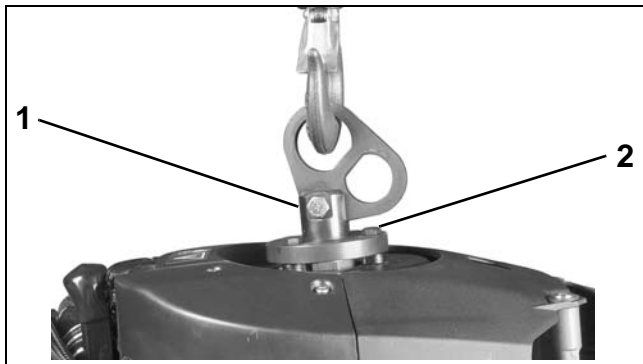

1. Lifting fixture 002098  
2. 1 1/8 in. screws

**NOTICE** Use only the 1 1/8 in. (short) screws, P/N 398067, included with the tool to avoid damage to electronic components under the flywheel.

Fasten appropriate chain hook to eye of tool. Carefully hoist outboard with chain and unbolt outboard mounting brackets from frame.

# OUTBOARD RIGGING CONNECTIONS

**IMPORTANT:** For complete outboard rigging and remote control installation information, refer to the **Predelivery and Installation Guide** included with the service manual set.

## Common Practices – All Models

### Control Cable Identification

**IMPORTANT:** Identify control cable function before rigging outboard.

Identify each control cable:

- Put the control handle into NEUTRAL position. The throttle cable casing guide will retract completely and the shift cable casing guide will go to the midpoint of its travel.

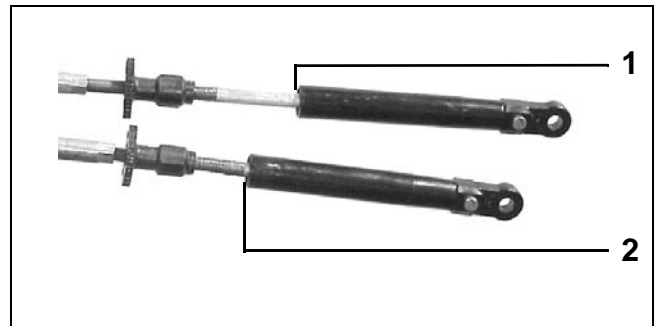

1. Shift cable casing guide extended to midpoint DP0811  
2. Throttle cable casing guide retracted

Extend the control cables and lubricate them with *Triple-Guard* grease.



30501

## ROUTINE SERVICE

### OUTBOARD RIGGING CONNECTIONS

#### Cable Retainer Clip Installation

When installing retainer clips on control arm linkage pins, clips should be locked and **must not** be bent or deformed.

For proper installation, review the following steps:

- Place washer on pin.
- Position retainer clip with straight section on the bottom and angled section on the top.
- Use long nose pliers to insert straight section of clip into linkage pin hole.

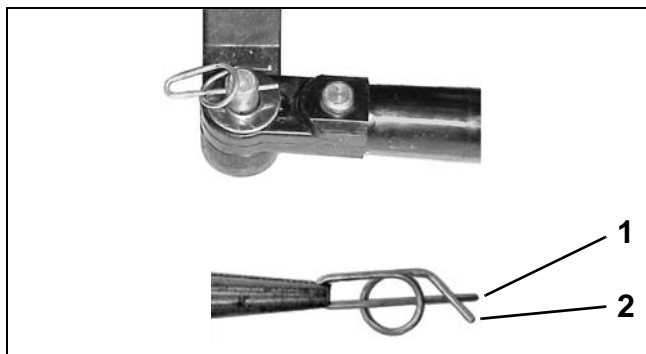

1. Straight section
2. Angled section

DP0818  
DP0817

- Push the clip towards the hole while lifting on the curved end with the pliers.
- Be sure retainer clip fully engages the pin.
- Lock the retainer by moving the angled section **behind** the straight section.



#### Locked Retainer Clip

1. Angled section behind straight section

DP0817a

#### Cable, Hose, and Wire Routing

#### ⚠ CAUTION

**To prevent accidental starting while servicing, disconnect the battery cables at the battery. Twist and remove all spark plug leads.**

Refer to **Control Cable Identification** on p. 17.

Apply soapy water to the inside surfaces of grommet and install cables and fuel line as shown:

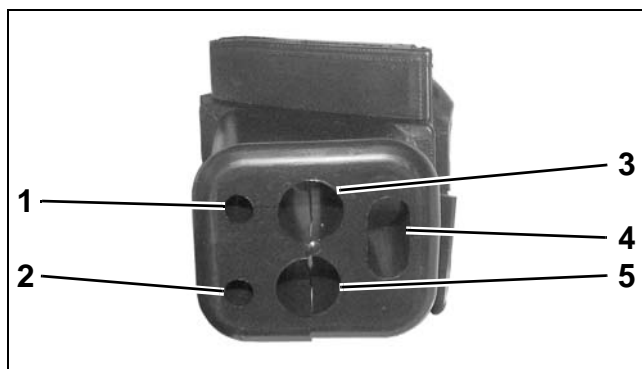

1. Throttle cable
2. Shift cable
3. Main wiring harness
4. Battery cable
5. Fuel line

001998

Place the grommet into position in the lower engine cover.



002104

When grommet is in place and all cables have been installed, tighten a tie strap around the outside of the grommet to form a watertight seal around the cables.

**NOTICE** After installation, make sure there is enough clearance for all cables to avoid binding or chafing through all engine steering and tilting angles.

### Control Cable Installation

Refer to **Control Cable Identification** on p. 17.

Remove cable retainer from anchor block. Apply *Triple-Guard* grease to both anchor block pockets.

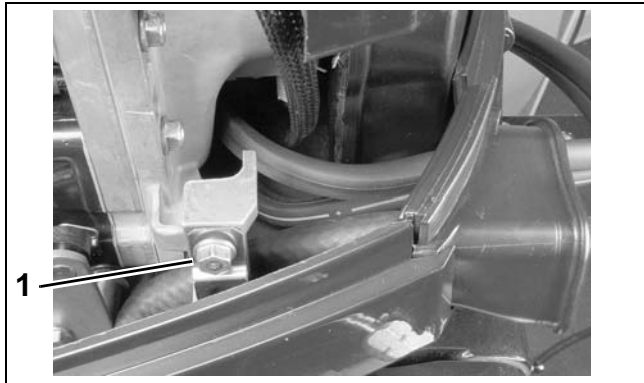

1. Cable retainer 002099

**IMPORTANT:** DO NOT secure cables to throttle and shift lever pins until all cables, wires, and hoses have been routed and grommet has been installed in the lower engine cover.

Make sure the remote control is in NEUTRAL, and throttle is in the IDLE position.

Pull firmly on shift cable casing to remove slack. With outboard in NEUTRAL, place the cable trunnion into the lower anchor pocket. Adjust the trunnion nut so the casing fits onto the shift lever pin.

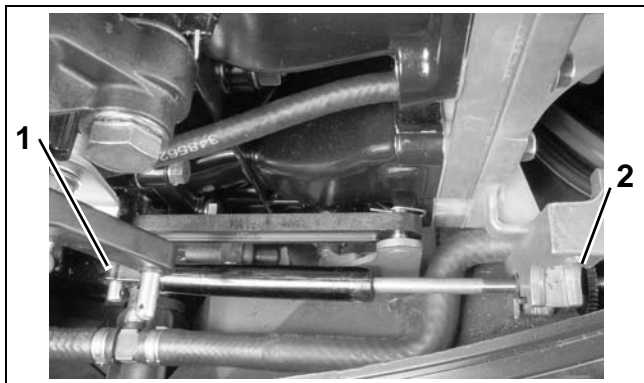

1. Shift lever pin 002100  
2. Trunnion nut

If there are not enough threads on the shift cable for the adjustment, or if the gearcase does not shift fully into FORWARD or REVERSE, refer to **SHIFT ROD ADJUSTMENT** on p. 300, or **SHIFT ROD ADJUSTMENT** on p. 323.

With remote control lever in NEUTRAL, pull firmly on throttle cable casing to remove slack.

With engine throttle lever against stop, place the cable trunnion into the upper anchor pocket and adjust the trunnion nut so the casing fits onto the throttle lever pin.

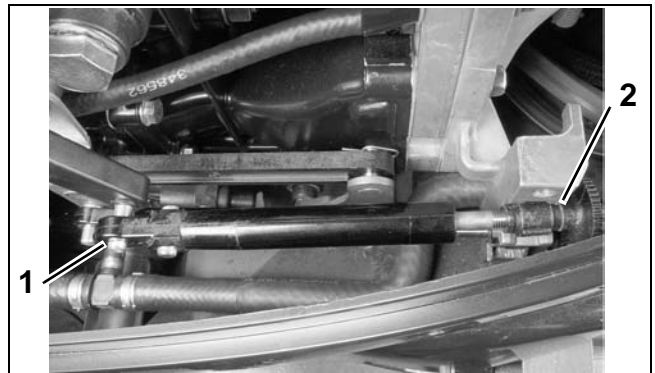

1. Throttle lever pin 002101  
2. Trunnion nut

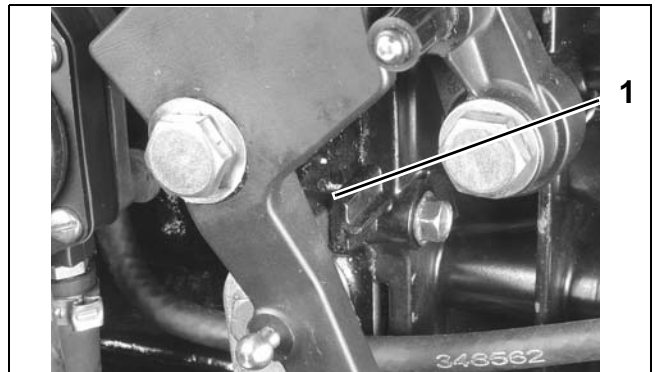

1. Throttle lever stop – 3 Cylinder models 005111



1. Throttle lever stop – 2 Cylinder models 005114

## ROUTINE SERVICE

### OUTBOARD RIGGING CONNECTIONS

**IMPORTANT:** Move control handle to FORWARD and pull back slowly to NEUTRAL. Make sure the engine throttle lever is against the stop. If not, remove slack by adjusting cable trunion.

After grommet has been installed in lower engine cover, install the washers and retainer clips on the throttle and shift lever pins. Refer to **Cable Retainer Clip Installation** on p. 18.

Install cable retainer and screw. Tighten screw to a torque of 60 to 84 in. lbs. (7 to 9.5 N·m).

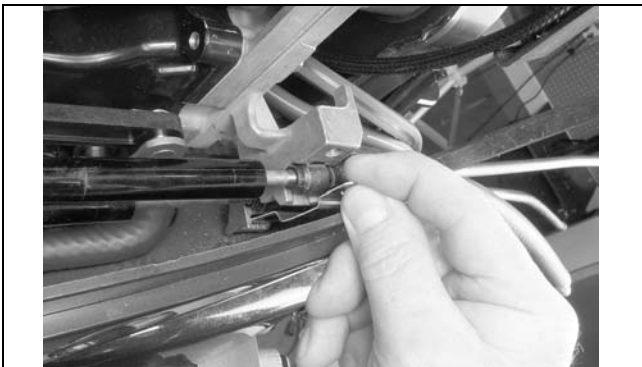

002103

### SystemCheck Harness Connections

Place the wiring harness through notch in lower motor cover and route to the recess in the flywheel cover. Secure the cable with a tie strap as shown:

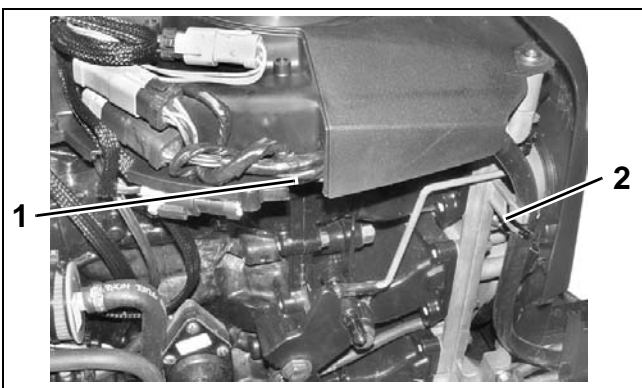

1. Recess
2. Tie strap

002011

Before installing electrical connectors, check that the seal is in place. Clean off any dirt from connectors. Apply a light coat of *Electrical Grease* to

the seal only. DO NOT fill connectors with *Electrical Grease*.

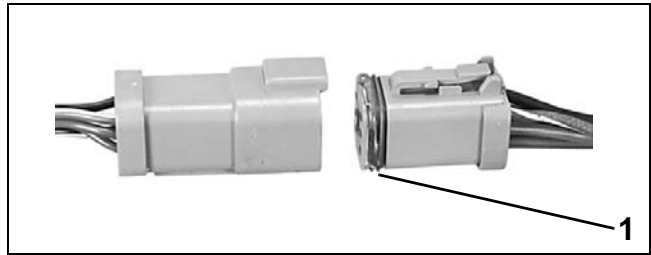

1. Seal

42079A

Arrange connectors in flywheel cover.

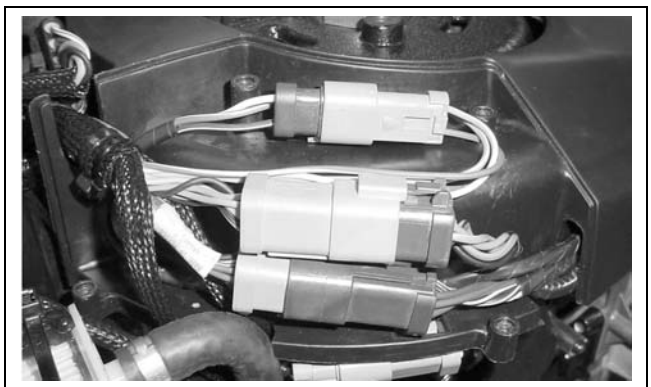

001999

Install electrical cover and secure with screws.

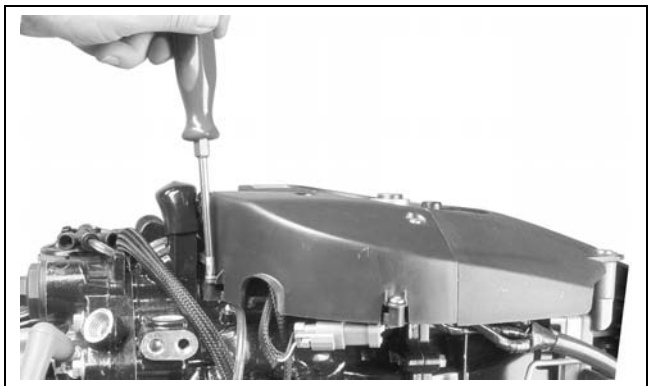

002102

**NOTICE** BE SURE all harnesses and wires are not pinched, cannot contact flywheel, and do not interfere with moving throttle or shift linkages.

### ***I-Command* Network Connections**

If the outboard will be used with *I-Command*, or other *NMEA 2000* compliant CANbus instruments, use the following connections to supply information to the network:

Remove lower motor covers. Remove air silencer.

Route *I-Command* Engine Interface Cable around the front of the throttle body, following the path of the TPS wiring, and behind the battery cable. Loosely install tie straps as shown.

**NOTICE** To prevent wire chafing, harness must be routed below the flywheel cover.

Connect the *I-Command* Engine Interface Cable to the *EMM* CANbus connector.

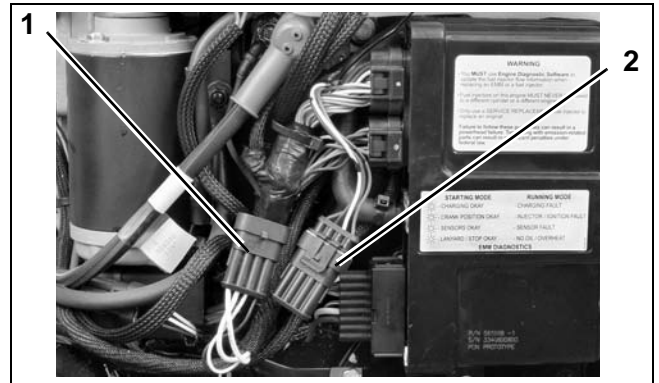

1. *I-Command* network connector  
2. *EMM* CANbus connector  
006735

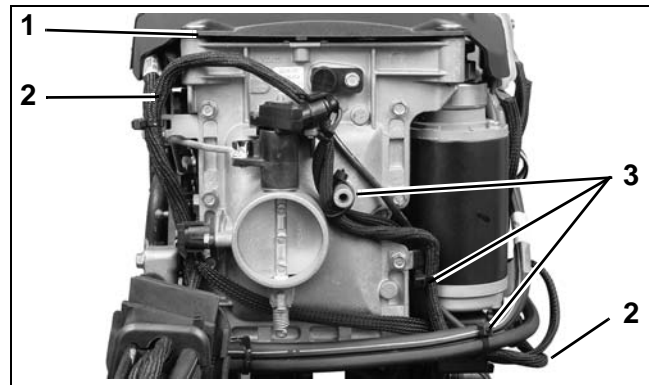

**2 Cylinder Models**  
1. Flywheel cover  
2. Harness routing  
3. Tie straps  
006736

### **2 CYLINDER MODELS**

To prevent interference with engine cover latch, bundle excess wiring behind *EMM* cooling water hose. Secure *I-Command* connectors to back side of engine harness with tie strap.

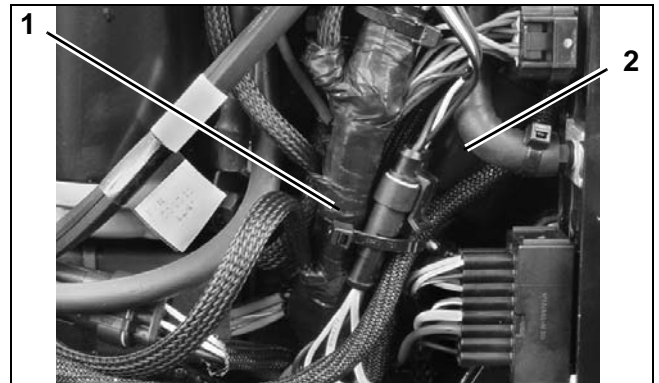

1. Engine harness  
2. *EMM* cooling water hose  
006738

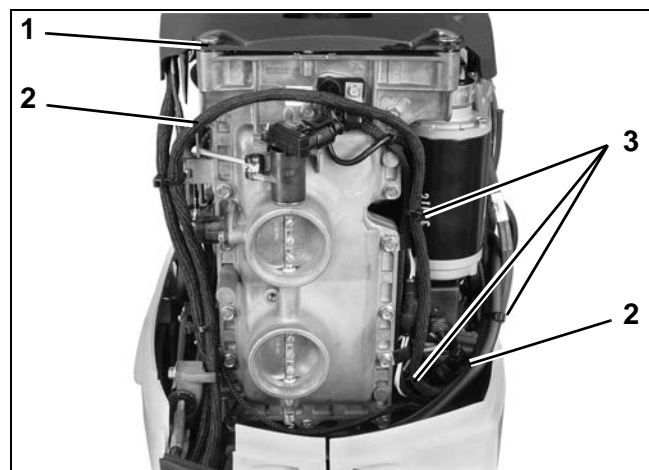

**3 Cylinder Models**  
1. Flywheel cover  
2. Harness routing  
3. Tie straps  
006742

## ROUTINE SERVICE

### OUTBOARD RIGGING CONNECTIONS

#### 3 CYLINDER MODELS

EMM CANbus connector cap is clipped to EMM cooling water hose. Remove clip from cap and install on *I-Command* harness connector.

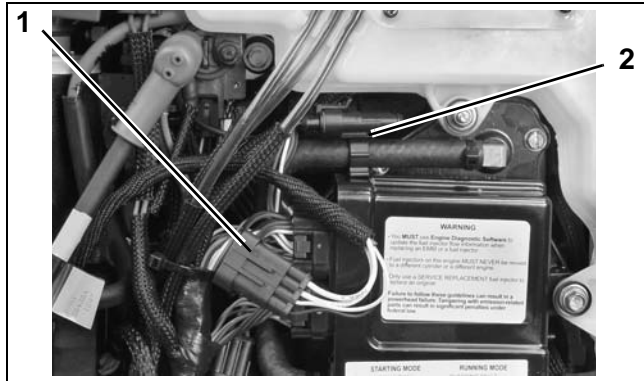

1. Canbus harness connector  
2. EMM CANbus connector cap and clip

Install clip and connector to hose.

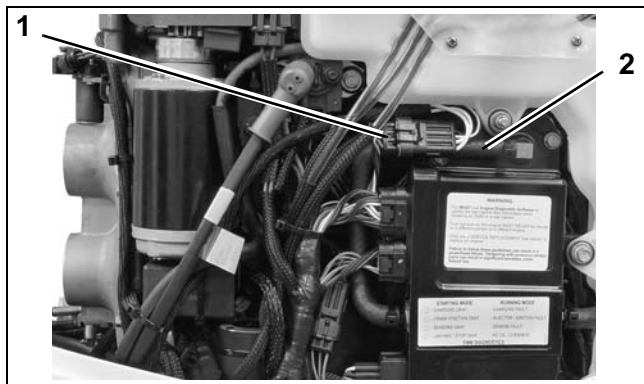

1. CANbus connectors  
2. EMM cooling water hose

#### ALL MODELS

Adjust harness routing as needed and secure with tie straps.

Use an *I-Command* Ignition and Trim Harness to connect the outboard to the key switch and trim/tilt control. Seal unused *SystemCheck* connector with 6-Pin Connector Seal, P/N 586076.

If connecting to an existing *I-Command* Classic network, connect the purple wires between the *I-Command* Ignition and Trim Harness and the *I-Command* Engine Interface Cable. This connection supplies power to the network when the key switch is on. *I-Command* Digital networks do not use this connection.

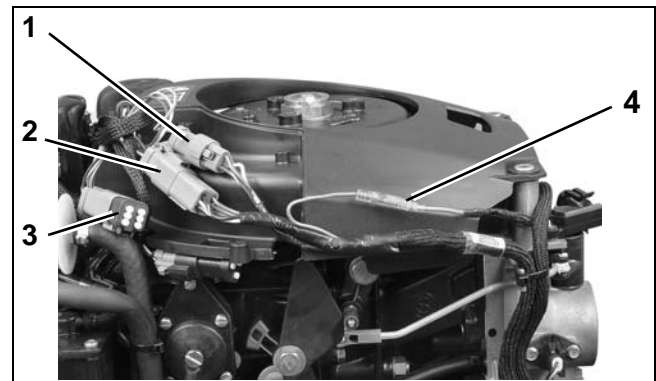

1. Trim/Tilt connector  
2. CANbus Ignition connector  
3. SystemCheck connector (with seal)  
4. Deutsch-style harness power connector



Route *I-Command* Ignition Harness through wire channel in flywheel cover. Install electrical cover. Make sure both harnesses are in front of the tab and tighten with tie strap.

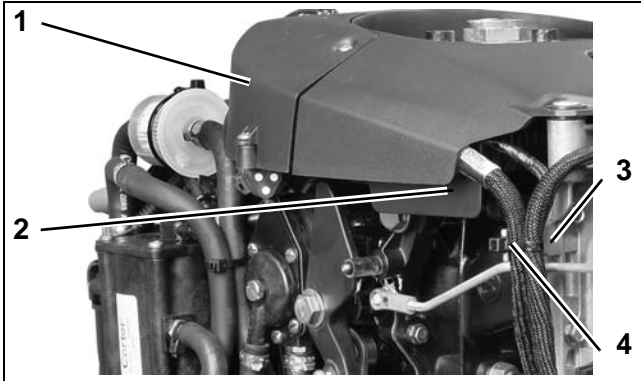

1. Electrical cover
  2. Wire channel
  3. Tab
  4. Tie strap
- 006737

Use *Evinrude Diagnostics* software to adjust network settings in the *EMM*. From the *Settings* screen, select *Engine Options*.



**Engine Options Screen** 008093

## Water Pressure Gauge

To display engine water pressure, install a water pressure hose fitting in the cylinder block as shown.

Use *Pipe Sealant with Teflon* on the threads of the hose fitting. Refer to installation instructions supplied with gauge.

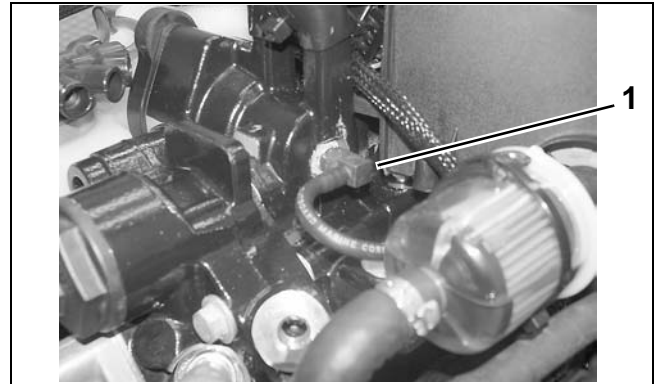

1. Water pressure hose fitting 002461

For an *I-Command* water pressure display, several water pressure sensor kits are available. Refer to the *Evinrude/Johnson Genuine Parts and Accessories* catalog.

## ROUTINE SERVICE

### BATTERY AND BATTERY CONNECTIONS

# BATTERY AND BATTERY CONNECTIONS

#### WARNING

Keep the battery connections clean, tight, and insulated to prevent their shorting or arcing and causing an explosion. If the battery mounting system does not cover the connections, install protective covers. Check often to see that connections stay clean and tight.

Check battery connections frequently. Periodically remove battery to clean and service connections.

- Confirm that battery meets the minimum engine requirements.
- Connections must be clean and tight.
- Observe all wiring connections prior to disassembly.

Disconnect battery negative (–) cable **first** and the battery positive (+) cable last.

Clean all terminals, battery posts, and connectors with a solution of baking soda and water. Use a wire brush or battery terminal tool to remove corrosion buildup. Rinse and clean all surfaces.

**IMPORTANT:** Connect the battery positive (+) cable to the battery positive (+) post **FIRST**. Connect the battery negative (–) cable to the battery negative (–) post **LAST**.

Install a starwasher on the threaded battery post. Stack cables from the outboard, then cables from accessories. Finish this connection with a hex nut.

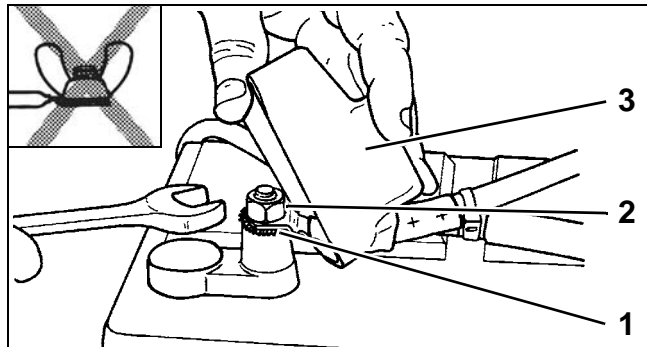

Marine Style Battery Post

DR5103

1. Starwasher
2. Hex nut
3. Terminal Insulator

**NOTICE** Do not use wing nuts to fasten ANY battery cables. Wing nuts can loosen and cause electrical system damage not covered under warranty.

Tighten all connections securely. Apply *Triple-Guard* grease to prevent corrosion.

#### WARNING

Battery electrolyte is acidic—handle with care. If electrolyte contacts any part of the body, immediately flush with water and seek medical attention.

# OETIKER CLAMP SERVICING

## Clamp Identification

Use *Oetiker* clamps for making hose connections. These clamps provide corrosion resistance, minimize the potential for abrasion of rigging components, and provide solid, permanent connections.

The selection and installation of an *Oetiker* clamp is essential in the proper sealing of hose connections. The clamp identification numbers appear on the side of the clamp, near the top of the ear. Refer to **Clamp Selection** chart for dimensions.

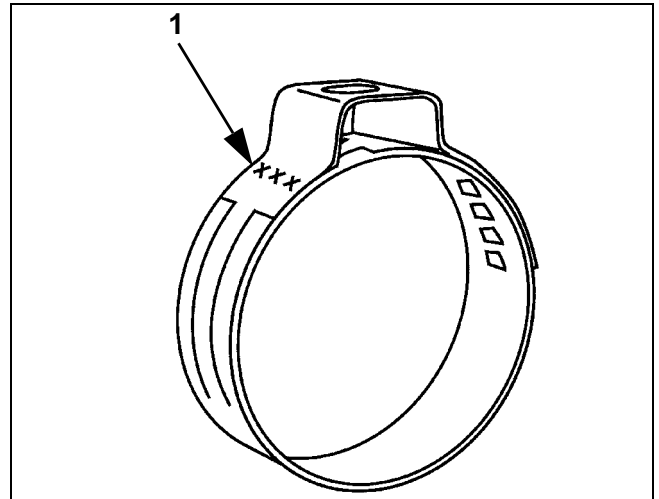

1. Clamp identification numbers

000093



### WARNING

**DO NOT re-use *Oetiker* clamps. Fuel leakage could contribute to a fire or explosion.**

## Clamp Selection

To select the correct size *Oetiker* clamp, measure the outside diameter of the hose when installed on the fitting.

Chose a clamp so that the outside diameter of the hose is approximately in the middle of the clamping range of the clamp.

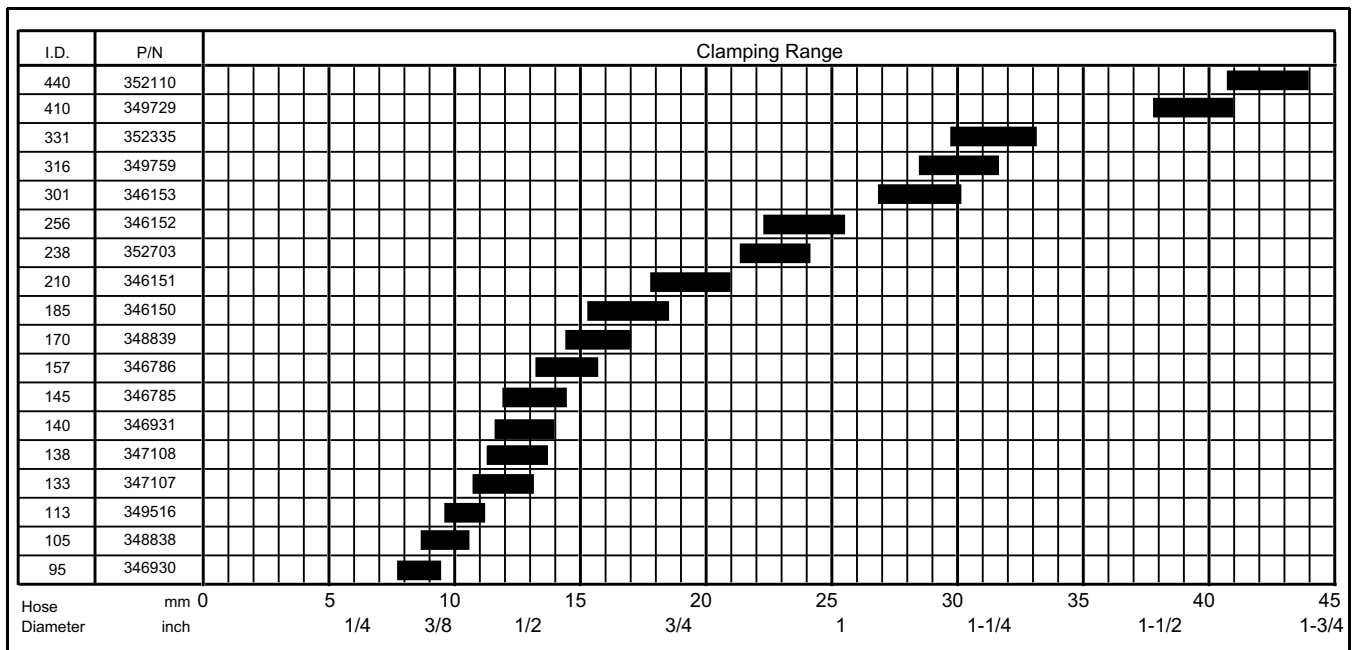

008458

## ROUTINE SERVICE

### OETIKER CLAMP SERVICING

#### Clamp Installation

A constant stress should be applied to close the ear clamps. This method ensures a positive stress on the hose and does not result in excessive compression or expansion of the band material.

**IMPORTANT:** Use only *Oetiker* recommended tools to close *Oetiker* stepless clamps.

*Oetiker* pincers are available in the *Evinrude/Johnson Genuine Parts and Accessories Catalog*.



DP0886

- Position correct size clamp over hose.
- Install hose on fitting.
- Close clamp ear fully with *Oetiker* pincers (pliers).

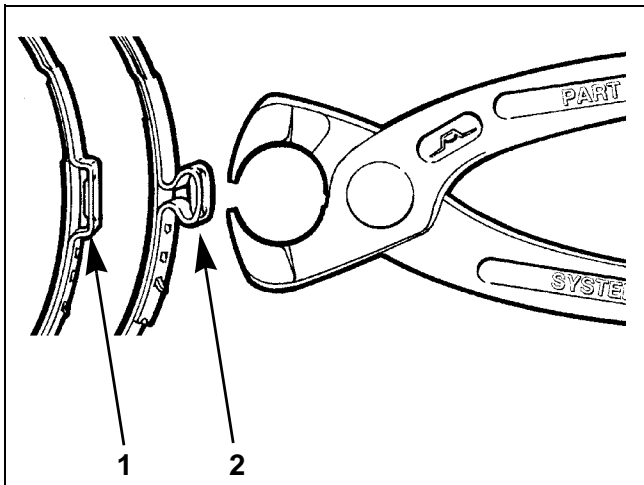

1. Open clamp
2. Closed clamp

000092

#### Clamp Removal

**Method 1:** Position *Oetiker* pincers across clamp ear and cut clamp.

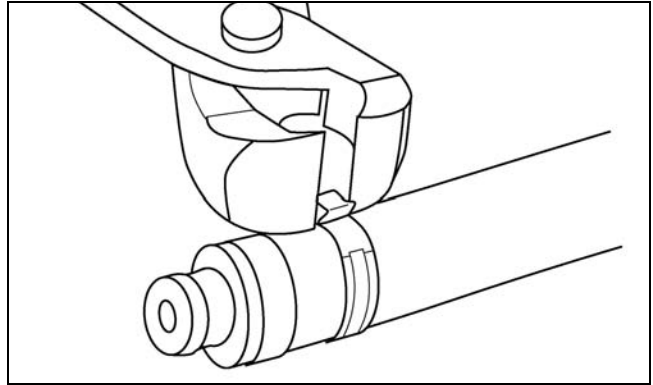

000108

**Method 2:** Lift end of stepless clamp with screwdriver.

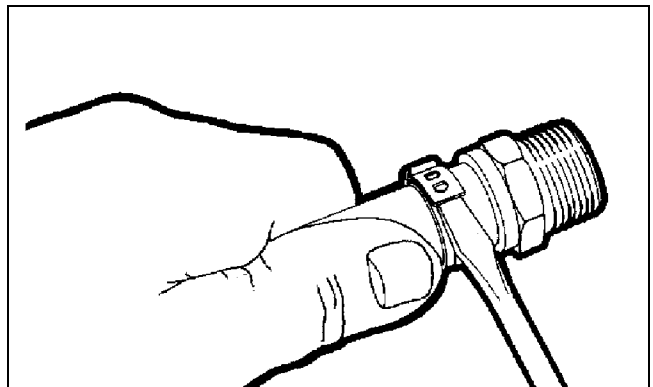

000090

**Method 3:** Use *Oetiker* pincers (pliers) to grip clamp. Pull clamp off of connection and discard.

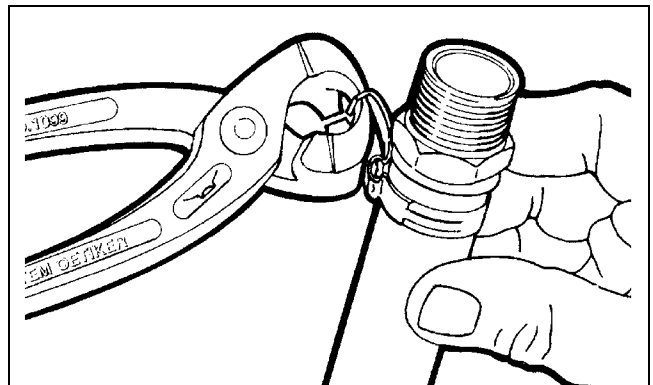

000091

# ADJUSTMENTS

## Steering Friction Adjustment

Tiller models are equipped with a steering friction adjustment. Steering friction is not required when remote steering is used.

Adjust steering friction with outboard mounted to boat by loosening or tightening the adjustment screw. Steering friction should be adjusted so a slight drag is felt when turning.

**⚠ WARNING**

Do not overtighten. The steering friction screw is not intended to allow “hands off” steering.

## Throttle Friction Adjustment

Tiller models are equipped with a throttle friction adjustment knob located on the steering handle. Tighten the knob to reduce the effort required to hold a throttle setting.

Turn the knob:

- clockwise to increase friction
- counterclockwise to decrease friction

**⚠ WARNING**

Tighten knob only enough to hold throttle at a constant engine speed. Overtightening will prevent quick throttle change in case of emergency.

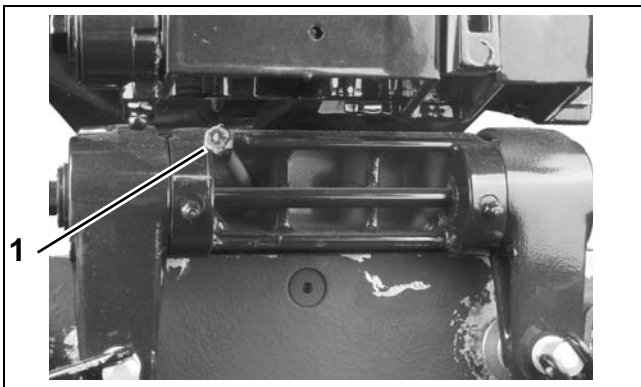

1. Steering friction adjustment—Manual tilt models 001256

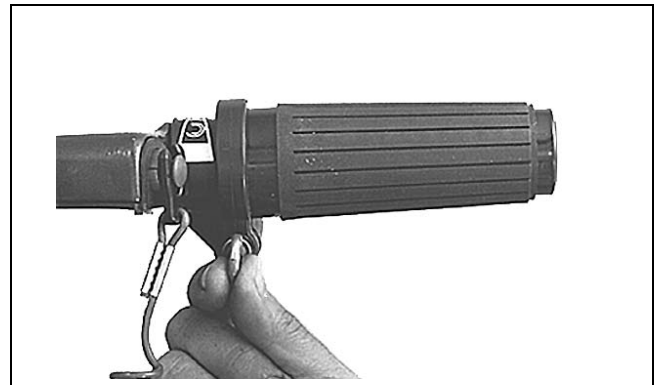

002191

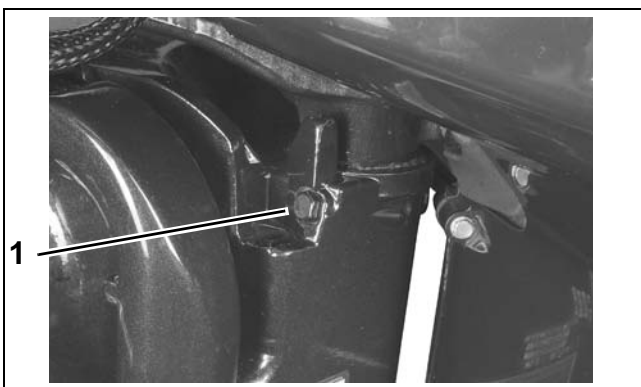

1. Steering friction adjustment—Power tilt models 005116

## ROUTINE SERVICE ADJUSTMENTS

### Tilt Limit Switch Adjustment (75 – 90 HP)

#### **⚠ WARNING**

If the outboard does not clear all boat parts when tilted fully or turned side to side, safety related parts could be damaged in the course of such outboard movement. Injuries could result from loss of boat control.

Adjust the tilt limit switch on all new outboard installations.

Check the clearance between outboard(s) and the boat's motor well and transom area. Tilt outboard(s) to highest point of clearance and turn the steering system lock to lock.

If the outboard contacts the boat's motor well when fully tilted, adjust the tilt limit cam to reduce full-tilt position.

**NOTICE** The tilt limit cam will not prevent the outboard from overriding the adjustment if the outboard is tilted manually.

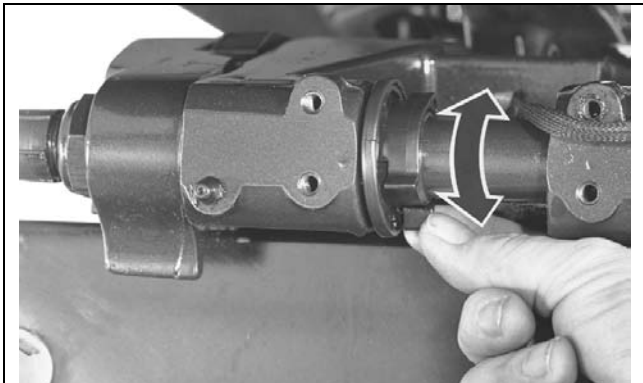

DR3916

Place the outboard in normal operating position.

Rotate the LOWER adjustment tab UP to reduce the maximum tilt. Rotate the UPPER adjustment tab DOWN to increase the maximum tilt position.

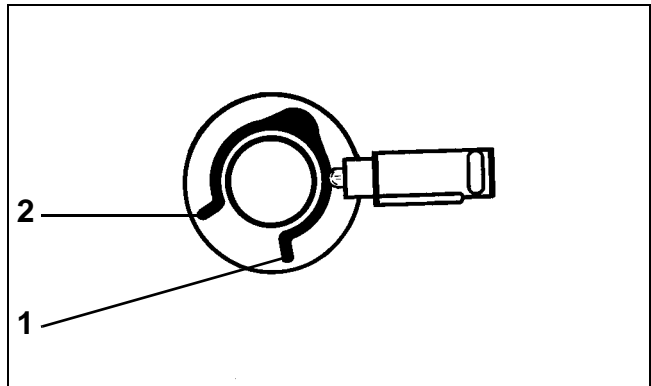

1. Lower adjustment tab
2. Upper adjustment tab

DR4268

Check the adjustment by tilting the outboard fully.

Repeat this procedure until the tilt limit switch stops the outboard's upward travel before it contacts the motor well.

To prevent damage to equipment, provide additional motor well clearance when needed. Consider either changing the outboard mounting position or modifying the boat if the possibility for interference and damage exists.

#### **⚠ WARNING**

Adjusting the tilt limit cam will NOT prevent the outboard from tilting fully and contacting the motor well if the gearcase hits an object at high speed. Such contact could damage the outboard and boat and injure boat occupants.

## Trim Sending Unit Adjustment (40 – 60 HP)

The sending unit eccentric cam must be adjusted so that the gauge needle is aligned with the lowest gauge mark with the outboard trimmed all the way DOWN.

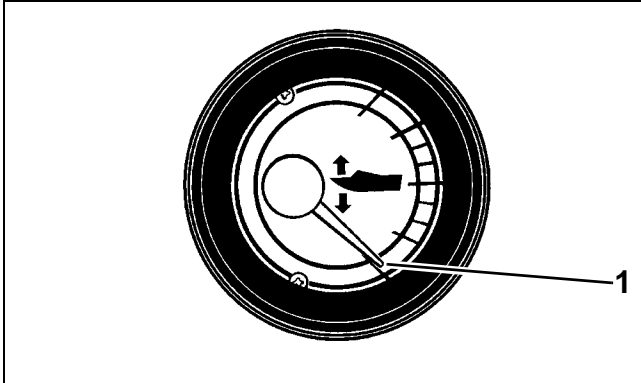

1. Lowest gauge mark

DR2827

Check if the gauge needle is above or below the lowest gauge mark. Tilt engine UP and engage trailering lock.

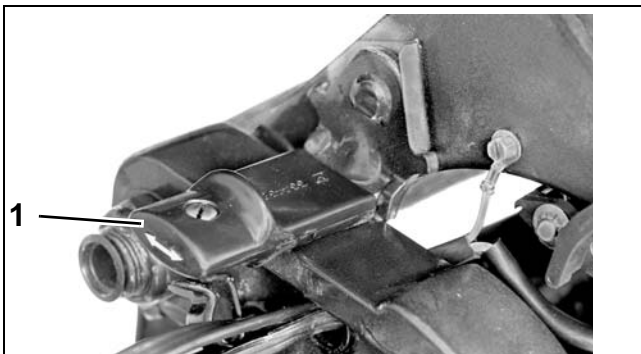

1. Trailering lock

18954

### ⚠ WARNING

To avoid personal injury, do not adjust the sending unit eccentric cam while the engine is being tilted.

When the outboard is trimmed all the way DOWN, the sending unit lever touches the eccentric cam just forward of the top of the cam at the contact point.

Loosen cam screw and rotate eccentric cam to adjust full down gauge position:

- If the needle was above the lowest mark, move the thick part of the cam TOWARD the contact point. Tighten the screw, and recheck the gauge reading.
- If the needle was below the lowest mark, move the thick part of the cam AWAY from the contact point. Tighten the screw, and recheck the gauge reading.

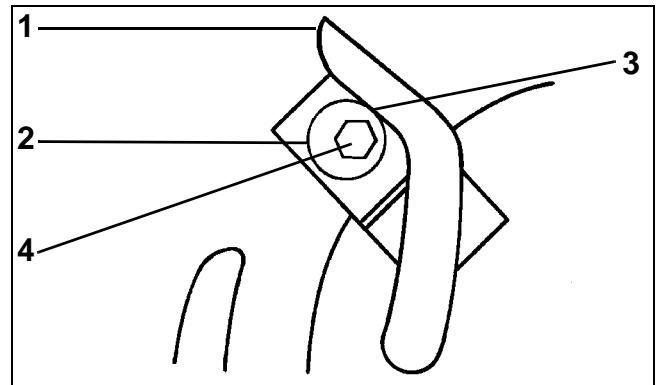

1. Lever
2. Eccentric cam
3. Contact point
4. Cam screw

DR5090

Tighten eccentric cam retaining screw and check needle position at full trim DOWN.



## ROUTINE SERVICE ADJUSTMENTS

### Trim Sending Unit Adjustment (75 – 90 HP)

Tilt the outboard and engage the tilt support.

Temporarily install a thrust rod, P/N 436541, in the number 3 hole.



29072

Loosen the sending unit screws, to allow the sending unit to pivot.

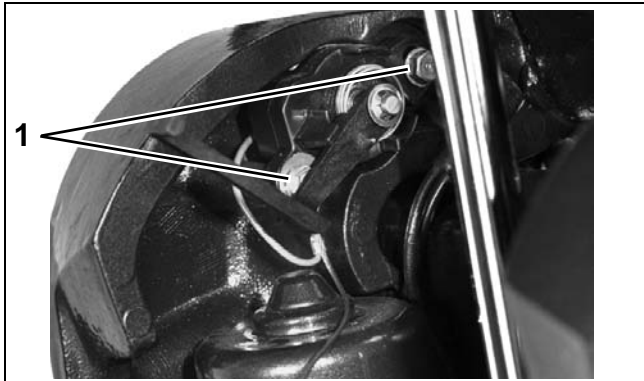

1. Screws

27339

Disengage the tilt support. Lower the outboard against the thrust rod.

Observe the trim gauge. If the needle does not show center position, tilt the outboard up and adjust the sending unit by pivoting it up or down.



1. Needle at center position

000662

Lower the outboard against the thrust rod to check adjustment. Repeat adjustment, if necessary.

After adjustment is correct, tilt the outboard up, tighten the two sending unit screws, and remove the thrust rod.

### Trim Limiter Rod

The trim limiter rod prevents excessive trim down.

As the engine is trimmed to the full down position, the bow of the boat goes deeper into the water.

- If the trim limiter rod is left out, the bow could plow into the water causing the boat to “bow steer” resulting in a loss of control.
- If the trim limiter rod is set too far out, the propeller could ventilate, resulting in poor acceleration when the boat is coming onto plane.

Set the trim limiter rod to prevent excessive trim down and provide good acceleration. The trim limiter rod can be used to prevent the gearcase or spray deflector from contacting the transom.

### WARNING

**When the outboard is returned to the customer, the trim limiter rod must be installed and in the same location as it was when the motor was brought in for service. Leaving the trim limiter rod out, or changing the adjustment, could allow the motor to unexpectedly trim in too far and cause loss of control.**

## Trim Tab Adjustment

**⚠ WARNING**

**Improper trim tab adjustment can cause difficult steering and loss of control.**

A propeller will generate steering torque when the propeller shaft is not running parallel to the water's surface. The trim tab is adjustable to compensate for this steering torque.

**IMPORTANT:** A single trim tab adjustment will relieve steering effort under only one set of speed, outboard angle and load conditions. No single adjustment can relieve steering effort under all conditions.

If the boat pulls to the left or right when its load is evenly distributed, adjust the trim tab as follows:

- With the remote control in NEUTRAL and the engine OFF, loosen the trim tab screw.
- If the boat pulled to the right, move rear of the trim tab slightly to the right.
- If the boat pulled to the left, move rear of the trim tab slightly to the left.

Tighten the trim tab screw as follows:

- **40 – 90 HP:** 35 to 40 ft. lbs. (47 to 54 N·m).

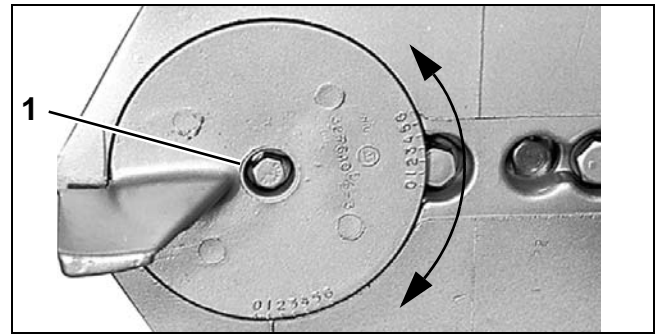

1. Trim tab screw

COA3663

2

Test the boat and, if needed, repeat the procedure until steering effort is as equal as possible.

### Outboards with High Transom Heights

The trim tab may be above the surface of the water when the outboard is trimmed out. Steering effort might increase. Lower the trim setting to submerge the trim tab and to reduce steering effort.

### Dual Standard Rotation Outboards

Move both trim tabs equally and in the same direction.

### Dual Outboards, One Counter and One Standard Rotation

Set both trim tabs to the center position.

---

## ROUTINE SERVICE ADJUSTMENTS

---

### Dual-Outboard Alignment

Dual outboards must be connected with a tie bar and adjusted to align the outboards for correct water flow to the gearcases and propellers.

Incorrect outboard alignment could cause one or more of the following:

- Propeller ventilation
- Reduction of top speed
- Improper boat tracking
- Engine overheat and powerhead damage

Follow the instructions provided by the tie-bar manufacturer for tie bar installation and adjustment.

### Measure Alignment

The “toe-in” (gearcase leading edges closer together than propeller shaft centers) or “toe-out” (gearcase leading edges farther apart than propeller shaft centers) is determined as follows:

- Position outboards straight with the anti-ventilation plates parallel with the bottom of the boat.
- Measure between propeller shaft centers.

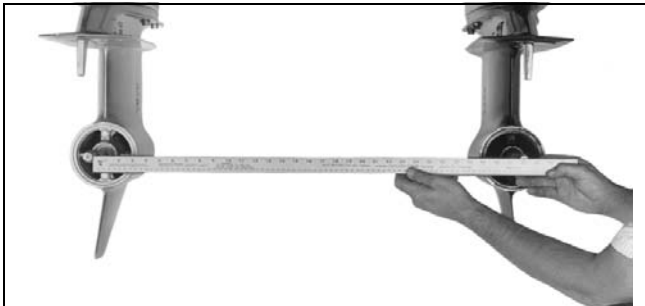

6365

- Measure between leading edges of gearcase.

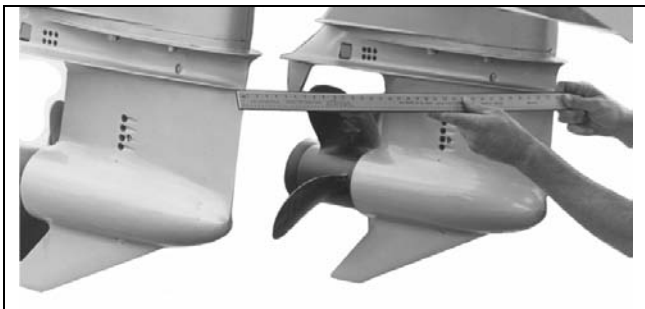

6340

### Alignment Adjustment

Various boat/motor combinations respond differently to dual-outboard alignments. Each application must be thoroughly tested until the ideal combination of performance, steering, and cooling is found.

A common practice is to set-up the outboards parallel, or with a small amount of “toe-out,” and adjust inward until best results are achieved.

- A typical set-up, with outboards mounted directly on the transom, often runs best with a slight amount of “toe-in.”
- Outboards mounted behind the transom on motor brackets usually require parallel alignment or “toe-out.”

Adjust the outboard alignments by adjusting tie bar. Follow the tie bar manufacturer's adjustment procedures.

Check steering operation. Make sure that the steering system operates properly at various trim angles.

### Confirm Alignment

To confirm proper alignment, perform the following steps:

- Water test the boat.
- Monitor the water pressure for both outboards.
- Run the boat at various trim angles.
- Perform steering maneuvers and vary the throttle settings.
- Monitor boat and outboard performance.

A sudden loss of water pressure or excessive propeller ventilation on one or both outboards may indicate a misalignment of the gearcases. Reset the outboard alignment and retest.

## OPERATIONAL CHECKS

### DANGER

**DO NOT** run the engine indoors or without adequate ventilation or permit exhaust fumes to accumulate in confined areas. Engine exhaust contains carbon monoxide which, if inhaled, can cause serious brain damage or death.

### WARNING

Contact with a rotating propeller is likely to result in serious injury or death. Assure the engine and prop area is clear of people and objects before starting engine or operating boat. Do not allow anyone near a propeller, even when the engine is off. Blades can be sharp and the propeller can continue to turn even after the engine is off.

### CAUTION

**DO NOT** run outboard without a water supply to the outboard's cooling system. Cooling system and/or powerhead damage could occur.

## Engine Monitoring System

Attach emergency stop lanyard.

### **SystemCheck**

Turn key switch to ON. Warning horn should sound for 1/2 second.

All *SystemCheck* warning lights should turn on at the same time, then turn off one at a time.

### **I-Command**

Turn key switch to ON.

The *Evinrude E-TEC* screen should appear, followed by the tachometer display.

## Fuel System

Perform running checks of the fuel system by following these steps:

- Squeeze fuel primer bulb until hard or activate electric primer. Observe all fuel hoses and connections. Repair any leaks.
- Start outboard. Inspect all hoses and connections. Repair any leaks or misrouted hoses immediately.

## Emergency Stop / Key Switch

Check emergency stop function. With outboard running at IDLE, pull safety lanyard from emergency stop switch. Outboard must stop immediately.

## Remote Control Operation

Make sure that control can be easily moved into all gear and throttle settings. Do not shift remote control when outboard is not running.

## Start-In-Gear Prevention

### WARNING

**Make certain that the starter will not operate when the outboard is in gear. The start-in-gear prevention feature is required by the United States Coast Guard to help prevent personal injuries.**

Start outboard and shift to FORWARD.

Turn outboard OFF while control is in FORWARD.

Try to restart the outboard. Outboard should not start.

Shift back to NEUTRAL and restart outboard.

Shift to REVERSE. Turn outboard OFF while control is in REVERSE.

Try to restart the outboard. Outboard should not start.

**ROUTINE SERVICE**  
**COOLING SYSTEM**

**Tachometer Pulse Setting**  
**(SystemCheck)**

Confirm accuracy of tachometer reading.

- Adjust dial on back of tachometer to required setting (the outboard should not be running).

Outboard Model	Tachometer Setting
40–90 HP	6 Pulse or 12 Pole

**Water Pump Overboard Indicator**

A steady stream of water should flow from the overboard indicator.

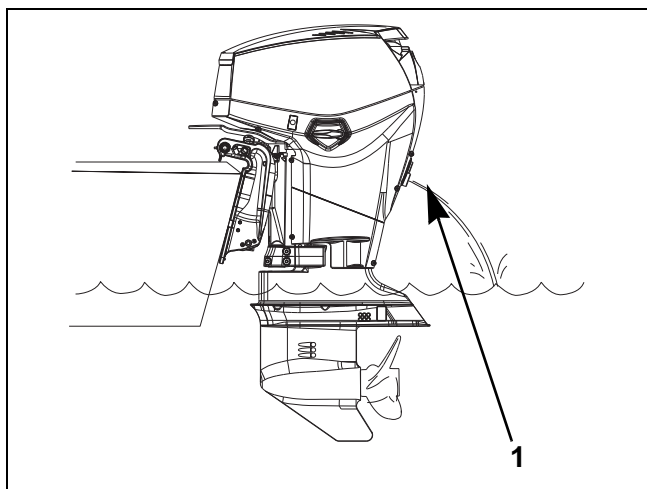

1. Water pump overboard indicator 008469

**Operating Temperature**

An outboard run at idle speed should achieve a temperature based on the engine’s thermostatic control. In general, the powerhead temperature should reach at least 104°F (40°C) after five minutes of idling. Check that the powerhead reaches idle temperature. Refer to **SERVICE SPECIFICATIONS** on p. 10.

**Idle Speed**

Make sure the outboard idles within the specified idle RPM range. If the outboard is run on a flushing device, the idle speed and quality may not be representative of actual in water use.

**COOLING SYSTEM**

Regularly inspect cooling system components for corrosion, damage, leaks, or restrictions:

- water intake screens
- water pump
- all internal water passages
- thermostats
- all external water hoses and fittings
- vapor separator cooling passages and fittings
- EMM cooling passages and fittings
- overboard water pressure indicator.

**Water Intake Screens**

Inspect condition of water intake screens. Clean or replace as needed.

Confirm function of overboard water pressure indicator.

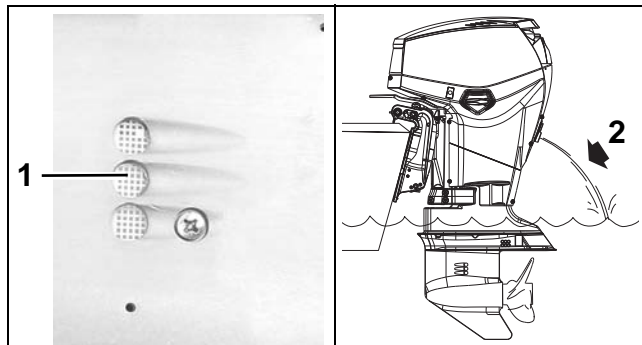

1. Water intake screen  
 2. Overboard indicator

001212  
 008470

## Engine Flushing

Flush the outboard with fresh water following each use in brackish, salt, or polluted water to minimize the accumulation of scale and silt deposits in cooling system passages.

The outboard can be flushed on the trailer or at dockside; running or not running.

**IMPORTANT:** The outboard must be located in a well ventilated area with appropriate ground drainage during the flushing procedure.

Keep water inlet pressure between 20 to 40 psi (140 to 275 kPa).

### Flushing — Outboard Running

**⚠ WARNING**

**To prevent injury from contact with rotating propeller, remove the propeller before flushing.**

Place outboard in VERTICAL (DOWN) position in a well ventilated area.

Thread garden hose into flushing port.

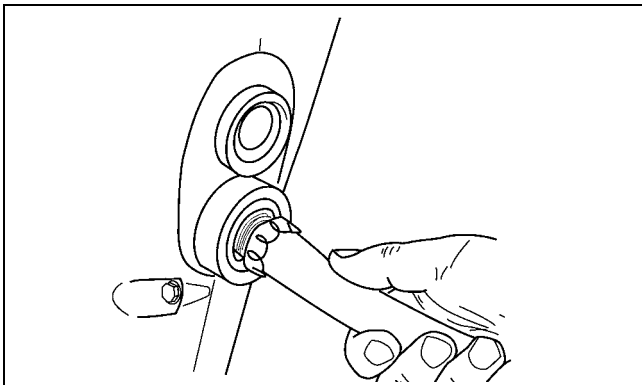

002024

Turn water supply on.

Run outboard at IDLE only until full operating temperature is reached.

Leave the outboard in VERTICAL (DOWN) position long enough for the powerhead to drain completely.

Reinstall propeller.

### Flushing — Outboard Not Running

Outboard can be in VERTICAL (DOWN) or TILTED (UP) position.

Thread garden hose into flushing port.

Turn water supply ON.

Flush outboard for at least five minutes.

Turn off water supply and remove garden hose.

Leave the outboard in VERTICAL (DOWN) position long enough for the powerhead to drain completely.

## ROUTINE SERVICE COOLING SYSTEM

### Running the Outboard Using a Hose and Flushing Adapter

#### WARNING

To prevent injury from contact with rotating propeller, remove the propeller before running engine with a flushing adapter.

A flushing adapter may be used to provide cooling water when running the outboard to:

- Flush the engine
- Run for an extended period of time, such as when performing diagnostic work
- Run the engine on a dynamometer
- Prepare the outboard for storage.

**IMPORTANT:** The outboard must be located in a well ventilated area with appropriate ground drainage.

Keep water inlet pressure between 20 to 40 psi (140 to 275 kPa).

Be sure water supply is sufficient to run the engine above idle speed.

#### Water Supply Requirements

Model	Water Flow @ WOT
40–65 HP	4 to 6.5 GPM <sup>1</sup> (15 to 24 LPM <sup>2</sup> )
75–90 HP	7.5 to 9 GPM (28 to 34 LPM)

1. GPM: Gallons per minute

2. LPM: Liters per minute

Install flushing adapter onto gearcase water inlet screens.



1. Flushing adapter

008342

A steady stream of water should flow from the overboard indicator while the engine is running.

Monitor engine water pressure gauge when:

- Engine speed is above 3000 RPM
- Running engine on a dynamometer.

Refer to **SERVICE SPECIFICATIONS** on p. 10 for water pressure requirements.

**NOTICE** Engine will overheat if normal water pressure is not maintained. Temporarily install an engine water pressure gauge if not equipped with one.



# LUBRICATION

## Steering System

**⚠ WARNING**

Failure to regrease as recommended could result in steering system corrosion. Corrosion can affect steering effort, making operator control difficult.

Grease the stainless steel output end of the steering cable with *Triple-Guard* grease.

Use an appropriate cleaning solvent to remove corrosion and dirt from output end of cable before coating it with grease. Make sure wiper nut is installed and not damaged.

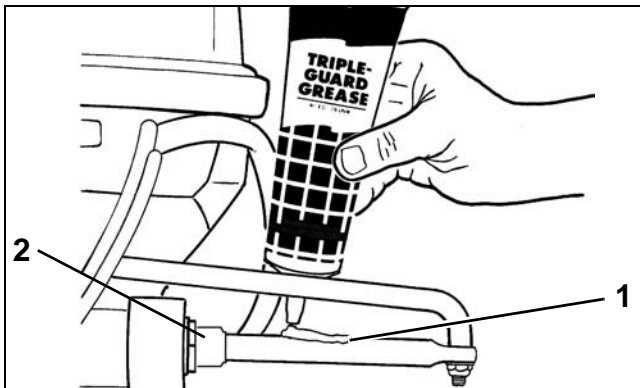

- 1. Steering cable
- 2. Wiper nut

DR29546

## Tiller Handle

Lubricate the tiller handle grease fittings with *Triple-Guard* grease.

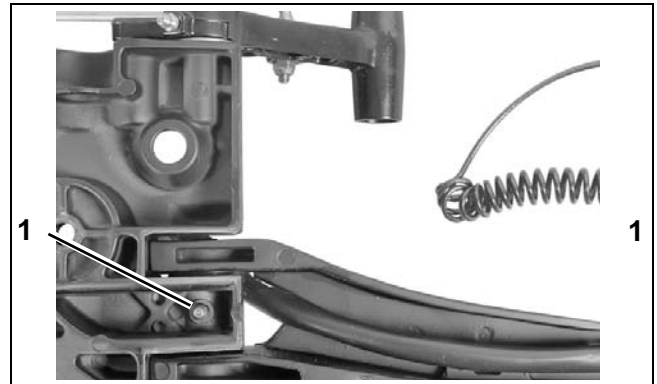

1. Tiller handle fittings – Standard handle

008196



1. Tiller handle fittings – Long handle

008197

## ROUTINE SERVICE LUBRICATION

### Swivel Bracket and Trailing Bracket

Lubricate the swivel bracket with *Triple-Guard* grease.

Apply grease until the grease begins to flow from the upper or lower swivel bracket areas.

Coat the pivot points of the trailing bracket with *Triple-Guard* grease.

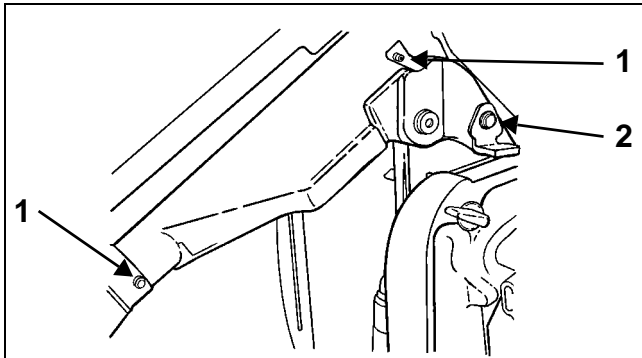

2-Cylinder models

1. Grease fitting
2. Tilt support

DR31329

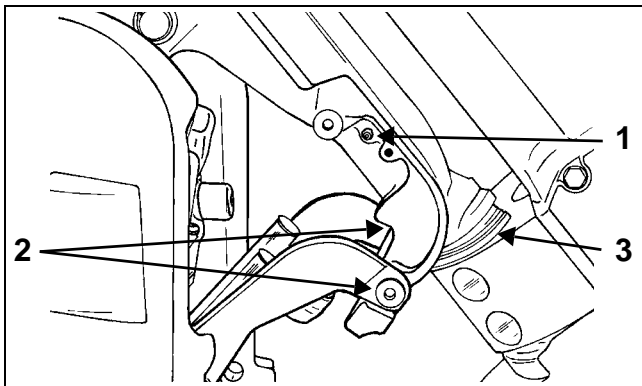

3-Cylinder models

1. Grease fitting
2. Pivot points
3. Lower swivel bracket area

DR5073

### Tilt Tube

Lubricate the tilt tube grease fittings with *Triple-Guard* grease.

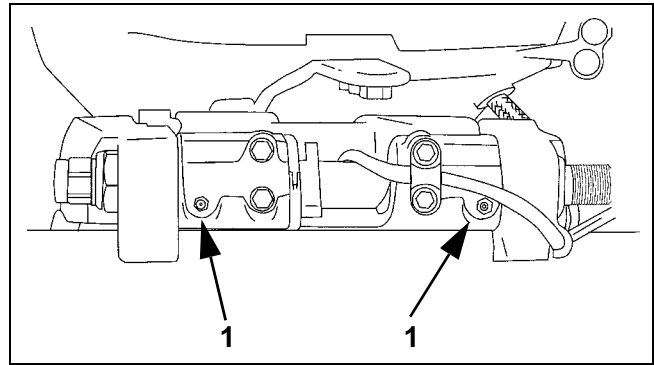

1. Tilt tube fittings

DR38798

### Throttle and Shift Linkage

Disconnect the battery cables at the battery.

Remove clips and washers from throttle and shift lever pins. Carefully, remove casing guides from pins.

**IMPORTANT:** DO NOT disturb cable trunnion adjustments.

Shift remote control into FULL THROTTLE/ REVERSE position to fully extend the plastic casing guides.

Apply *Triple-Guard* grease to:

- Cable attachment pins of both the throttle and shift levers
- Inner casings of both the throttle and shift cables.

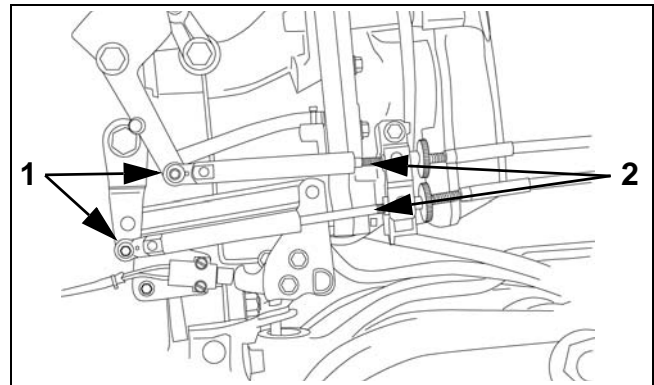

1. Attachment pins, throttle and shift cables  
2. Inner casings, throttle and shift cables

002214

Shift the remote control to the NEUTRAL/IDLE position.

Install control cables.

Check proper throttle and shift function.

## Propeller Shaft

Debris from the water can become lodged around propeller shaft. Frequent inspection can minimize potential gearcase damage.

### ⚠ WARNING

**When servicing the propeller, always shift the outboard to NEUTRAL, turn the key switch OFF, and disconnect the battery cables at the battery.**

Remove propeller. Refer to **Propeller Hardware Installation** on p. 294.

Inspect bushing and blade surfaces. Replace damaged or worn propellers.

Clean propeller shaft. Inspect propeller shaft seals. Replace damaged or worn seals.

Apply *Triple-Guard* grease to entire length of propeller shaft prior to installing propeller.

Reinstall propeller hardware and propeller.

## Gearcase Lubricant

### Draining

#### ⚠ WARNING

**Gearcase lubricant may be under pressure and/or hot. If plug is removed from a recently operated outboard, take precautions to avoid injury.**

**IMPORTANT:** Always check the fill level of the gearcase lubricant at the upper plug before removing the lower, drain/fill plug. A tie strap can be used to check lubricant level.

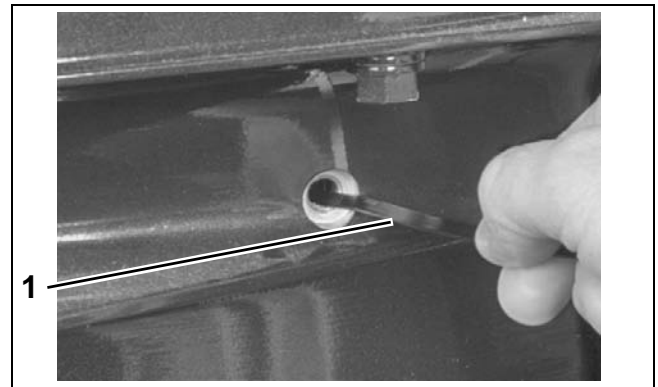

1. Tie strap

000072

If lubricant level is low, refer to **GEARCASE LEAK TEST** on p. 295.

Remove the lubricant level plug, then the lubricant drain/fill plug, and drain the lube from the gearcase into a container.

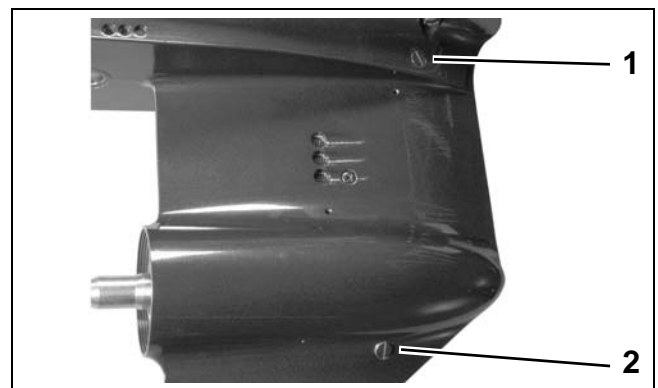

1. Lubricant level plug  
2. Lubricant drain/fill plug

001993

---

## ROUTINE SERVICE

### LUBRICATION

---

#### Inspection

Inspect the lubricant and the magnets on the plugs for metal chips. The presence of metal **fuzz** can indicate normal wear of the gears, bearings, or shafts within the gearcase. Metal **chips** can indicate extensive internal damage.

Inspect the lubricant for water contamination. Water can make the lubricant milky in appearance. However, normal aeration can also cause the same appearance.

To check for water contamination, put lubricant into a glass container. Allow the oil to settle for a minimum of one hour to determine if there is an abnormal amount of water in the oil.

If water is present, refer to **GEARCASE LEAK TEST** on p. 295.

Overheated lubricant will have a black color and burned odor.

Internal gearcase inspection is recommended when lubricant is contaminated or shows signs of failure.

#### Filling

Refer to the **INSPECTION AND MAINTENANCE SCHEDULE** on p. 16 for service frequency and recommended lubricants.

Secure the gearcase in a vertical position.

Remove the lubricant level plug and the lubricant drain/fill plug.

Use Gearcase Filler, P/N 501882, to slowly fill the gearcase with *HPF PRO* lubricant through the drain/fill hole until it appears at the oil level hole.

**IMPORTANT:** Filling the gearcase too quickly can cause air pockets and the gearcase may not fill completely.

Clean plug seal area and install the lubricant level plug and **new** seal, then the lubricant drain/fill plug and **new** seal. Tighten plugs to a torque of 60 to 84 in. lbs. (7 to 9.5 N·m).



1. Lubricant level plug
2. Lubricant drain/fill plug

27023

**IMPORTANT:** The recommended gear lubricants are formulated for marine applications. Do not use automotive gear lubricants, engine oils, or any other oil or grease.

## Trim and Tilt

**⚠ CAUTION**

**Correct fluid level must be maintained to ensure operation of the impact protection built into the unit.**

Check reservoir fluid level at least every three years or 300 operating hours.

- **40–60 HP:** System capacity is approximately 15.2 fl. oz. (450 ml).
- **75–90 HP:** System capacity is approximately 21 fl. oz. (620 ml).
- Tilt the outboard and engage the tilt support.

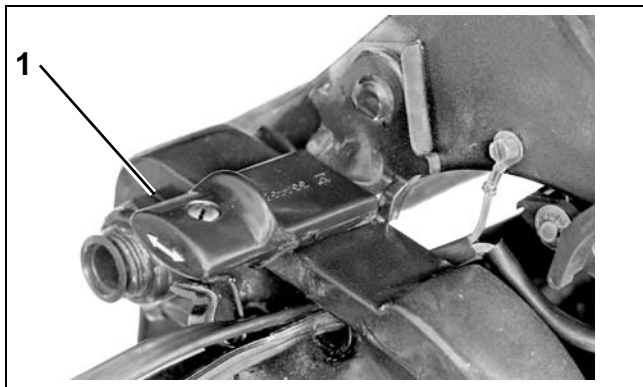

1. Tilt support bracket, 40-60 HP

18954

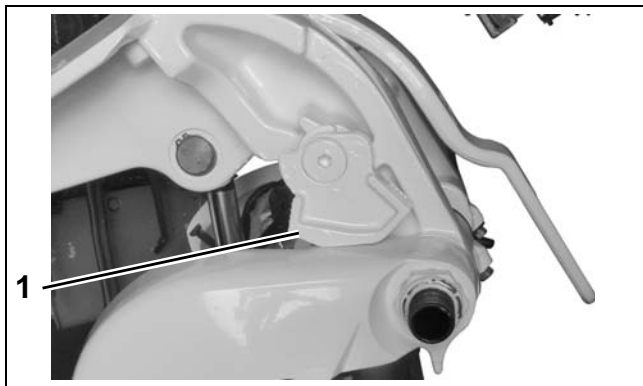

1. Tilt support bracket, 75-90 HP

002279

- Remove filler cap and check fluid level.

- **Single Ram System**—Add *Evinrude/Johnson* Biodegradable TNT Fluid, as needed, to bring level to the bottom of the fill plug threads.

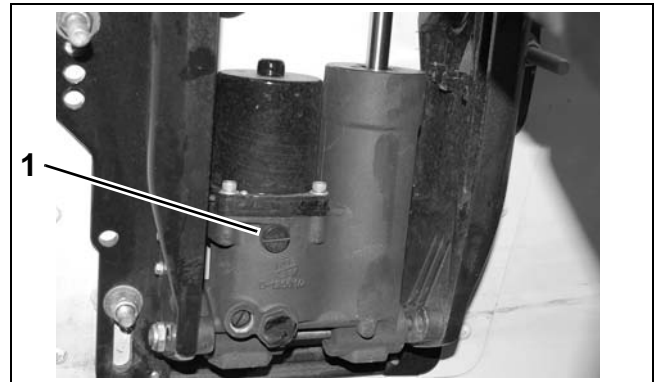

Single Ram System, 40 - 60 HP

008018

1. Filler cap

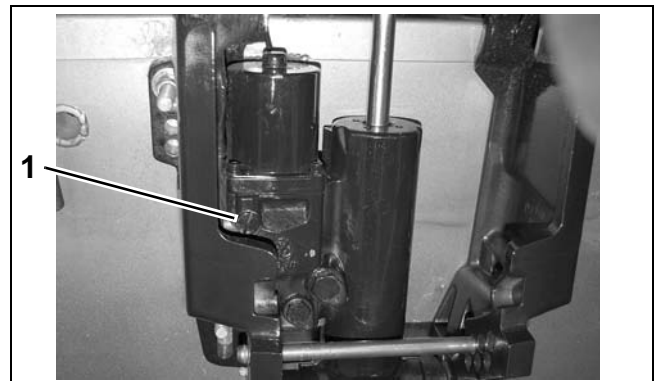

Single Ram System, 79 - 90 HP

008017

1. Filler cap

Install the filler cap and tighten to a torque of 45 to 55 in. lbs. (5 to 6 N·m).

- Disengage tilt support.
- Cycle the unit at least five complete cycles to purge all air from the system. When cycling the unit, hold the trim switch ON an additional 5 to 10 seconds after the unit reaches the end of its travel before activating the switch in the opposite direction.

## ROUTINE SERVICE

### SPARK PLUGS

# SPARK PLUGS

Spark plugs should be removed and examined periodically. Replace worn, fouled or damaged spark plugs.

Use only recommended spark plugs with the correct gap setting.

<b>Spark Plug, <i>Champion</i></b>
QC10WEP @ 0.028 ± 0.003 in. (0.71 mm)

- Remove spark plugs and inspect condition.
- Set spark plug gap on new, replacement spark plugs.
- Mark spark plugs for ground electrode orientation.
- Apply *Electrical Grease* to the ribbed portion of the spark plug ceramic and to the opening of the spark plug cover to prevent corrosion.
- Install spark plugs using “indexing” procedure.

## Removal

Remove ignition coil above spark plug to gain access. When reinstalling coils, tighten screws to a torque of 60 to 84 in. lbs. (7 to 9.5 N·m).

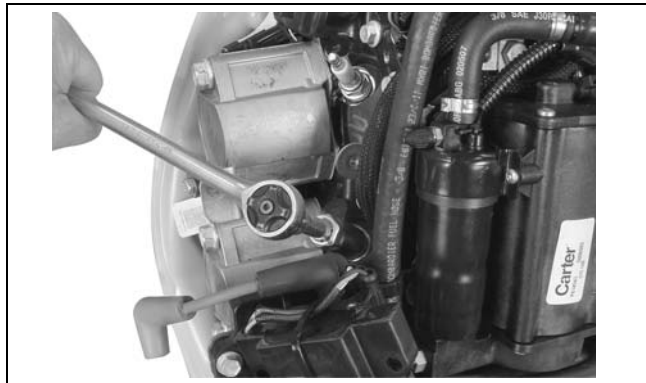

006521

## Indexing

Spark plug indexing positions the ground electrode of the spark plug opposite the fuel injector nozzle.

Put an ink mark on the ceramic of the spark plug in line with the OPEN side of the ground electrode. This mark will be used to orient the spark

plug with the OPEN side of the ground electrode facing the fuel injector.



1. Ink mark
2. Open side

000758

Apply *Triple-Guard* grease to the gasket surface of the spark plug. Install spark plug and tighten to a torque of 15 ft. lbs. (20 N·m).

If the mark is in unshaded area do not tighten anymore.

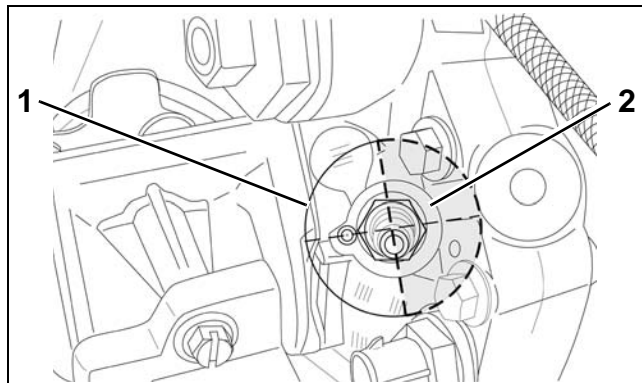

**Spark Plug Indexing Diagram**

002106

1. Unshaded area
2. Shaded area

If the mark is in the shaded area, reset torque wrench to 30 ft. lbs. (41 N·m) and continue to turn until the mark is in the unshaded area.

If the mark does not reach the unshaded area before the torque of 30 ft. lbs. (41 N·m) is reached, the spark plug cannot be indexed for that cylinder. Try another spark plug and repeat the steps above.

## FUEL AND OIL SYSTEMS

Routine replacement of filters reduces the possibility of foreign material restricting the incoming fuel or oil supplies.

Replacement filter elements are available through *Evinrude/Johnson Genuine Parts*.

### Fuel Filter

*Evinrude E-TEC* 40–90 HP outboards are equipped with an in-line fuel filter. Refer to **FUEL COMPONENT SERVICING** on p. 142.

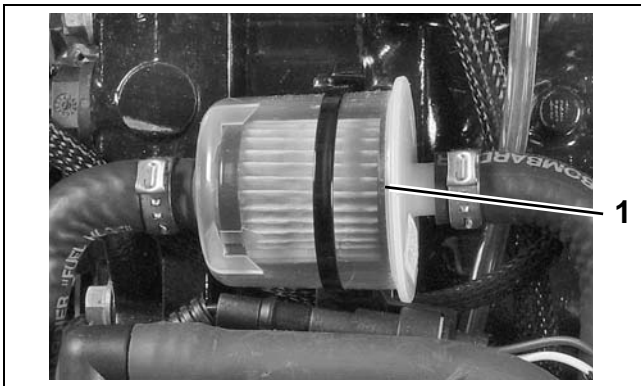

1. In-line fuel filter

002145

### Oil Filters and Oil Reservoir

Perform visual inspections to identify oiling system leaks. Make certain the oil tank is filled and oil supply is not contaminated.

### Air Silencer

The air silencer maximizes air flow while minimizing noise.



40 - 65 HP

002227



75 - 90 HP

002158

Routine cleaning of the air silencer is recommended to remove any accumulation of debris.

### Hoses and Connections

Check condition of all hoses and connections in both the fuel and oil systems:

- Visually inspect all components.
- Observe all clamps, hoses, and connections while outboard is running.
- Replace all damaged components.
- Repair all leaks.

#### **WARNING**

**Failure to check for fuel leakage could allow a leak to go undetected, resulting in fire or explosion.**

# ANTI-CORROSION PROTECTION

## Sacrificial Anodes

Galvanic corrosion occurs in fresh or salt water. Salt, brackish, and polluted water can accelerate corrosion. "Sacrificial" anodes are intended to protect the underwater metal components of the outboard from galvanic corrosion.

Outboards are equipped with three sacrificial anodes.

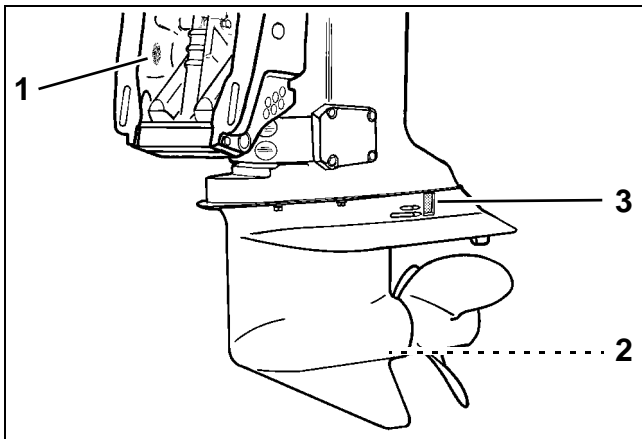

1. Stern bracket anode
  2. Propeller shaft bearing housing anode (inside of gearcase housing)
  3. Gearcase housing anode
- DR5082

Visually inspect anodes and metal components below water level. Erosion of anodes is normal and indicates the anodes are functioning properly.

**IMPORTANT:** Anodes that are not eroding may not be properly grounded. Anodes and the mounting screws must be clean and tight for effective corrosion protection.

For best anode performance:

- Replace all anodes that have eroded or disintegrated to two-thirds of their original size.
- Do not paint or apply protective coatings to anodes or anode fasteners.
- Avoid using metal-based antifouling paint on the boat or outboard.

## Testing Procedure – Continuity

Connect ohmmeter leads between engine ground and anode surface.

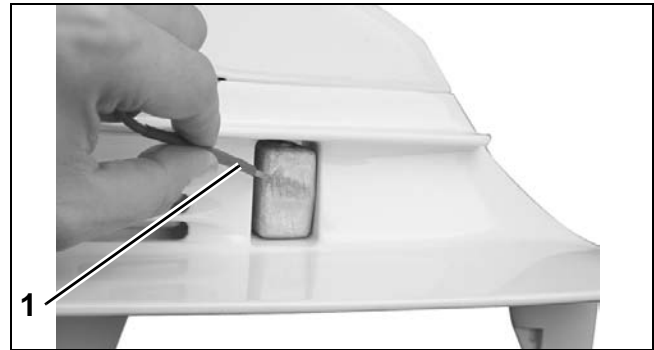

1. Meter lead to anode

000677

The meter should show little or no resistance. If resistance is high, check the following:

- Remove the anode and clean the area where the anode is installed
- Clean the mounting screws
- Install the anode and test again.

## Metallic Component Protection

Protect metal components on outboards from corrosion. Use the following products to minimize corrosion:

- *Anti-Corrosion Spray* provides a heavy, waxy coating to protect components
- *"6 in 1" Multi-Purpose Lubricant* provides a thin film of anti-corrosion protection.

## Exterior Finishes

Maintain the outboard's exterior finish to prevent corrosion and reduce oxidation:

- Use automotive wax to protect the outboard's exterior finish from oxidation
- Clean regularly using clean water and mild detergent soap
- Touch-up damage to painted surfaces promptly.



# STORAGE

**IMPORTANT:** DO NOT start outboard without a water supply to the outboard's cooling system. Cooling system and/or powerhead damage could occur.

## Fuel System Treatment

Stabilize the boat's fuel supply with *Evinrude/Johnson 2+4 Fuel Conditioner* following the instructions on the container.

## Internal Engine Treatment

Remove the propeller, attach garden hose to flushing port and turn on water.

*Evinrude E-TEC* models are designed to be self-winterizing using either of the following methods:

**IMPORTANT:** Engine MUST be in NEUTRAL throughout these procedures.

### Throttle Control Method

- Advance throttle control to 1/2 throttle (50%) position and then start the outboard. All four *SystemCheck* lights will turn on and the outboard will run at idle speed.
- After approximately 15 seconds, the *System-Check* lights will go off. Move throttle to IDLE position. *SystemCheck* lights will light again.
- Wait another 15 seconds. *SystemCheck* lights will go off. At this point, advance throttle to FULL (in neutral). *SystemCheck* lights will flash, indicating that outboard is in winterize mode.
- Outboard will automatically go to fast idle and fog itself. Allow outboard to run until it shuts itself off (about one minute).

**IMPORTANT:** If *SystemCheck* lights do not flash, or outboard runs above fast idle, immediately turn off outboard and start the procedure again.

### Software Control Method

Winterization can also be run using *Evinrude Diagnostics* software. With the outboard running, start the process at the *Settings/Adjustments* screen and follow the instructions.



1. Winterization start button

008077

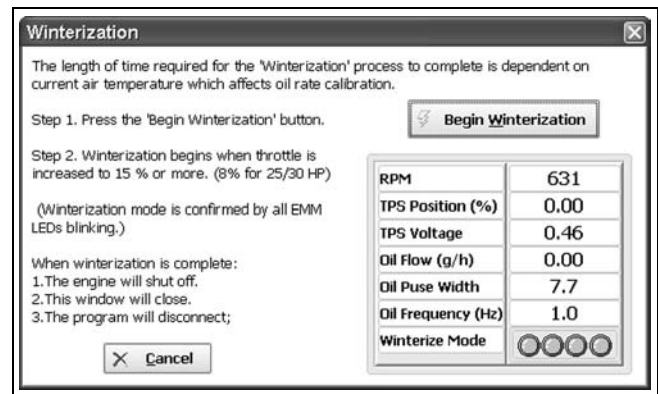

008119

After the outboard shuts itself off, turn key switch OFF, then detach garden hose.

**IMPORTANT:** When finished, leave the outboard in vertical position long enough to completely drain the powerhead.

---

## ROUTINE SERVICE

### PRE-SEASON SERVICE

---

### Additional Recommendations

- Fill oil reservoir.
- Inspect the fuel filter. If there is debris in the fuel filter, it must be replaced.
- Replace gearcase lubricant.
- Remove and inspect propeller.
- Clean and grease propeller shaft.
- Blow water from gearcase speedometer pickup system (gearcase speedometer models only).
- Lubricate all grease fittings and linkages.
- Inspect outboard, steering system, and controls. Replace all damaged and worn components. Refer to manufacturer's and lubrication recommendations.
- Touch up painted surfaces as needed. Coat outer painted surfaces with automotive wax.
- Remove battery(s) from boat. Store in a cool, dry location. Periodically charge battery(s) while stored. Refer to manufacturer's maintenance recommendations when servicing batteries.
- Store outboard in upright (vertical) position.
- Check for fuel leakage.

#### **WARNING**

Failure to check for fuel leakage could allow a leak to go undetected, resulting in fire or explosion.

## PRE-SEASON SERVICE

If the outboard was removed from the boat for storage, make sure it is reinstalled with factory specified hardware. Refer to the **Predelivery and Installation Guide**.

### Outboard Mounting Bolts

- Check and re-tighten outboard mounting bolts to a torque of 40 ft. lbs. (54 N·m).

### Gearcase Lubricant

- Check the lubricant level.
- Inspect gearcase for leaks. If leak is apparent, pressure and vacuum test gearcase.
- Repair gearcase as needed.

### Battery(s)

- Replace batteries that cannot be charged.

### Power Trim and Tilt

- Remove filler cap and check fluid level.
- Inspect the power trim and tilt unit for leaks. Repair as needed.

### Operational Checks

- Refer to **OPERATIONAL CHECKS** on p. 33
- Steering system
- Remote controls
- All other accessories and instrumentation

### Check Oil Injection Tank

- Inspect the oil tank for leaks.

### Check Fuel System

- Inspect entire fuel system for leaks before starting outboard.
- Repair all leaks.

### Water Pump

- Make sure a steady stream of water flows from overboard indicator.

#### **WARNING**

Failure to check for fuel leakage could allow a leak to go undetected, resulting in fire or explosion.

## SUBMERGED ENGINES

Once an outboard has been submerged in fresh or salt water, it must be serviced within three (3) hours of recovery. Immediate service can minimize the corrosive affect that air has on the polished surfaces of the crankshaft, connecting rods, and internal powerhead bearings.

**IMPORTANT:** If outboard cannot be started or serviced immediately, it should be resubmerged in fresh water to avoid exposure to the atmosphere.

### Engine Dropped Overboard (Not Running)

Disconnect the battery cables at the battery.

Rinse powerhead with clean water.

Remove spark plug leads and spark plugs.

Place outboard in horizontal position (cylinder heads down). Slowly rotate flywheel in a clockwise rotation to work all water out of powerhead.

**IMPORTANT:** If sand or silt may have entered the outboard, DO NOT attempt to start it. Disassemble and clean.

Disassemble all electrical connectors. Clean connectors and terminals, and treat with water displacing electrical spray. Apply *Electrical Grease* to terminals prior to reassembly. Coat all exposed solenoid terminals and engine grounds with *Black Neoprene Dip*.

Clean and inspect all electrical components. Replace damaged or corroded components prior to returning the outboard to service. Electric starters should be disassembled, cleaned, flushed with clean water, and treated with water displacing electrical spray prior to reassembly.

Disconnect fuel supply hose from outboard. Drain and clean all fuel hoses, filters, and fuel tanks.

Disconnect oil supply hose and oil return hose from outboard. Drain and clean all oil hoses, filters, and oil tank assemblies.

Refill fuel tank with fresh fuel and oil tank with recommended oil.

Prime oil system and fuel system. Refer to **FUEL SYSTEM PRIMING** on p. 136 and **Oil Supply Priming** on p. 165. Make sure all oil injection hoses are clean and filled with oil.

Make sure high pressure fuel system does not contain water. Flush as needed.

Inject a small amount of outboard lubricant into spark plug holes and install new spark plugs. Refer to Spark Plug **Indexing** on p. 42.

Reinstall all removed or disconnected parts.

Use *Evinrude Diagnostics* software to:

- Initiate Break-in
- Check fuel pump operation
- Check injector operation (fuel and oil)
- Check timing (once outboard is running at full operating temperature)

Run outboard below 1500 RPM for one-half hour.

### Engine Dropped Overboard (Running)

Follow the same procedures as **Engine Dropped Overboard (Not Running)**. However, if there is any binding when the flywheel is rotated, it may indicate a bent connecting rod and no attempt should be made to start the outboard. Powerhead must be disassembled and serviced immediately.

### Engine Dropped Overboard (In Salt Water)

Follow the same procedures used for **Engine Dropped Overboard (Not Running)** and **Engine Dropped Overboard (Running)**. Disassemble and clean outboards that have been submerged in salt water for prolonged periods of time. Clean or replace electrical components as necessary.

### Prolonged Submersion (Fresh or Salt Water)

Outboards that have been dropped overboard and not recovered immediately, must be serviced within three hours of recovery. Follow the same procedures used for **Engine Dropped Overboard (Not Running)** and **Engine Dropped Overboard (Running)**.



# ENGINE COVER SERVICE

## TABLE OF CONTENTS

UPPER COVER SERVICE .....	50
LATCH HOOK INSTALLATION .....	50
LOWER COVER SERVICE .....	50
LOWER COVER REMOVAL .....	50
LOWER COVER INSTALLATION .....	51
LATCH HANDLE INSTALLATION .....	52
TRIM SWITCH INSTALLATION .....	52

## UPPER COVER SERVICE

### Latch Hook Installation

Insert threaded bracket into pocket.

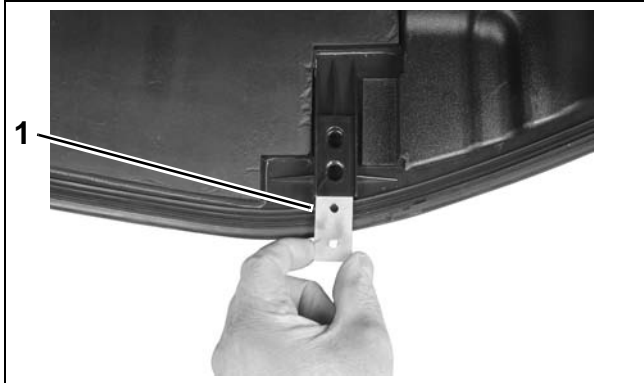

1. Bracket

006468

Apply *Ultra-Lock* to screw threads. Place hook into position with opening toward the front. Tighten screws to a torque of 60 to 84 in. lbs. (7 to 9.5 N·m).

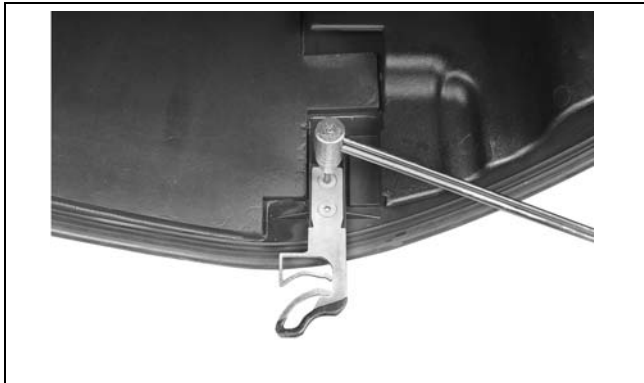

006469

## LOWER COVER SERVICE

### Lower Cover Removal

Remove lower engine cover screws.

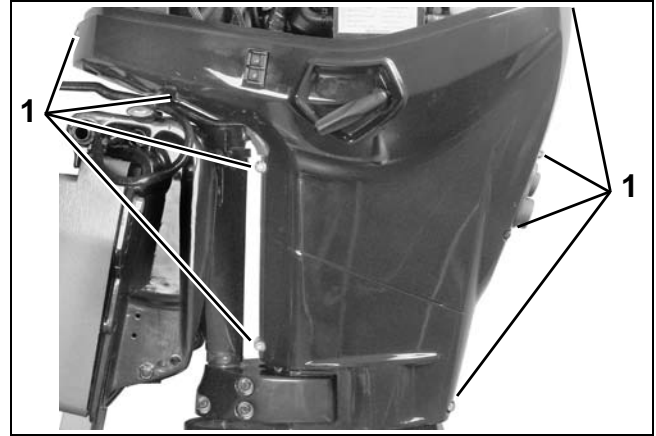

1. Lower cover screws

002168

Loosen port side cover slightly, and disconnect trim/tilt switch connector. Then, remove port and starboard covers.

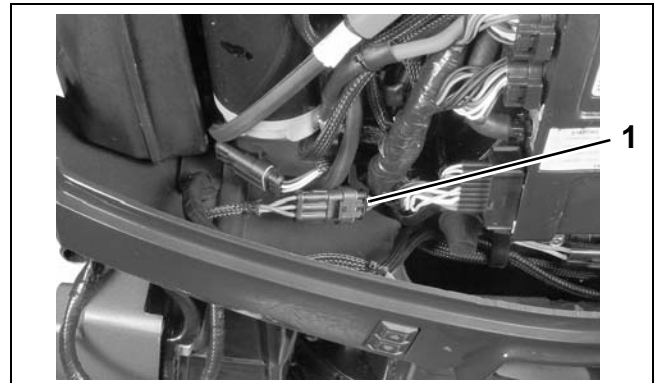

1. Trim/tilt switch connector

002169

## Lower Cover Installation

Installation of lower motor covers will be easier if the following steps are performed in order:

- Install air silencer on throttle body.
- Place starboard cover on outboard and route fuel hose and battery cable through grommet notch.
- Insert trim cable grommet into port side cover.
- Connect trim/tilt switch connector.
- Place port side cover into position on outboard.

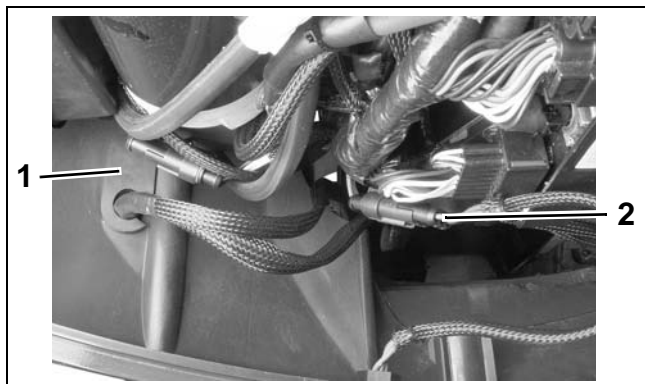

1. Trim cable grommet  
 2. Trim/tilt switch connector  
 002216

Start the screw above the exhaust relief grommet first. Tighten just enough to hold the grommet in place.

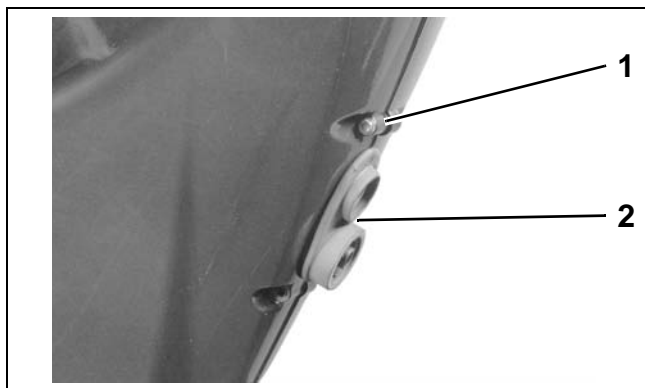

1. Start this screw first  
 2. Exhaust relief grommet  
 002157

Start the top front screw next and draw cover halves together.

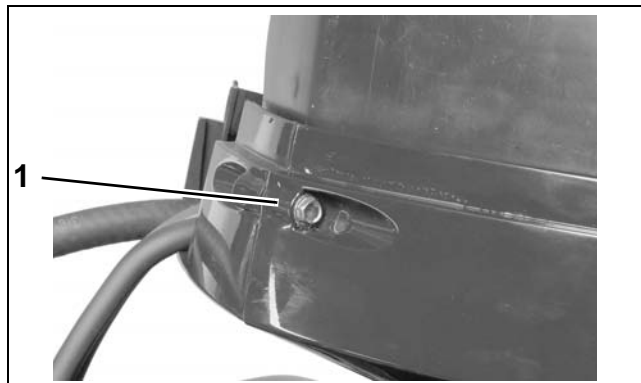

1. Start this screw second  
 002165

Install remaining cover screws and tighten all screws to 24 to 36 in. lbs. (3 to 4 N·m).

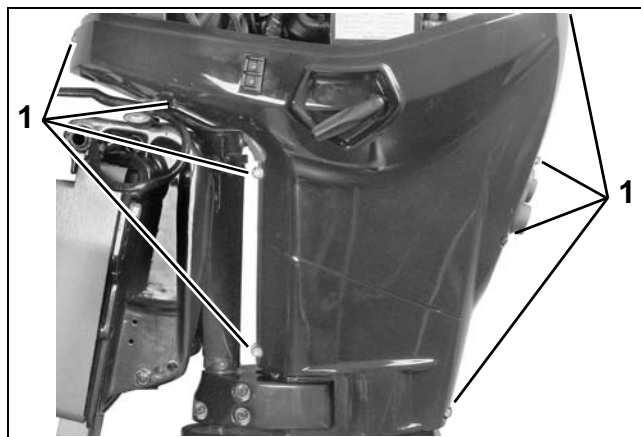

1. Lower cover screws  
 002168

## ENGINE COVER SERVICE

### LOWER COVER SERVICE

#### Latch Handle Installation

Apply a light coat of *Triple-Guard* grease to latch handle shaft. Insert handle into lower cover.

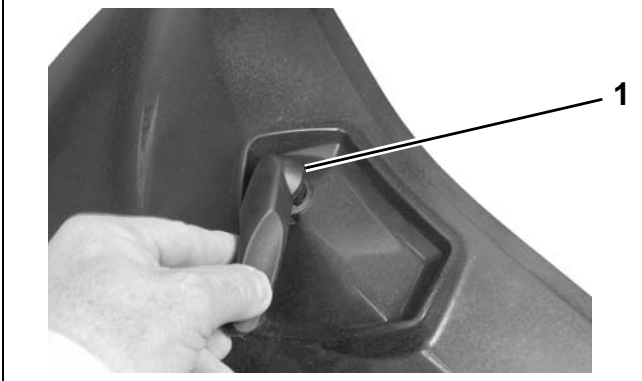

1. Triple-Guard grease

006470

Apply *Ultra-Lock* to screw threads. Place spring washer and hook into position and tighten screw to a torque of 180 in. lbs. (20 N·m).

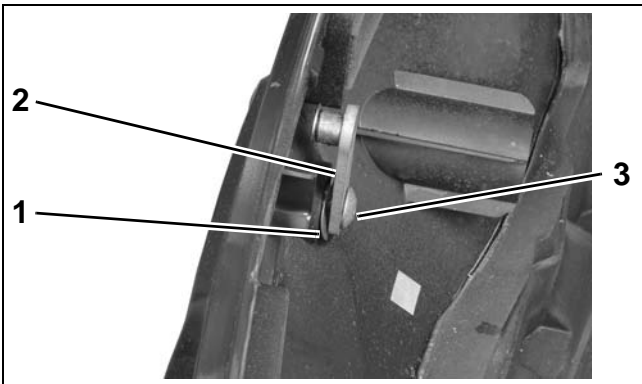

1. Spring washer
2. Hook
3. Screw

006471

#### Trim Switch Installation

Place switch into position through cover.

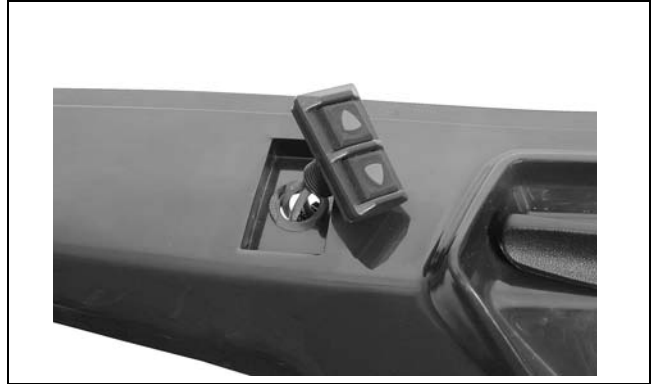

006746

Install nut on switch. Tighten nut to a torque of 10 to 16 in. lbs. (1 to 2 N·m).



006747

Install electrical connector. Refer to **CONNECTOR SERVICING** on p. 116.

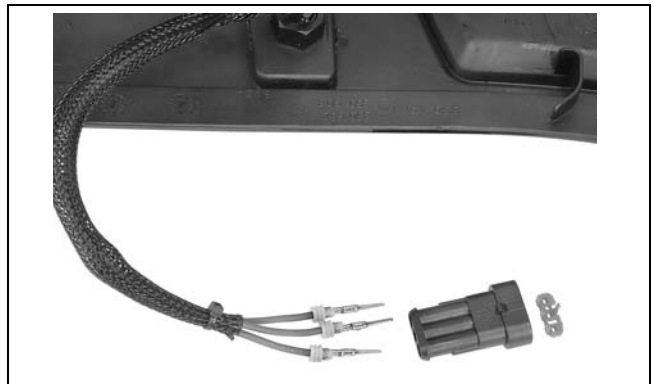

006748



# ENGINE MANAGEMENT MODULE (*EMM*)

## TABLE OF CONTENTS

DESCRIPTION .....	54
EMM FUNCTIONS .....	54
EMM CONNECTIONS .....	54
LED INDICATORS .....	54
<b>EMM INPUTS AND OUTPUTS DIAGRAM .....</b>	<b>55</b>
<b>INTERNAL SENSORS .....</b>	<b>56</b>
<i>EMM</i> TEMPERATURE SENSOR .....	56
55 V CIRCUIT SENSOR .....	56
12 V CIRCUIT SENSOR .....	56
5 V CIRCUIT SENSOR .....	57
BAROMETRIC PRESSURE SENSOR .....	57
<b>EXTERNAL SENSORS .....</b>	<b>57</b>
AIR TEMPERATURE SENSOR .....	57
ENGINE TEMPERATURE SENSOR .....	57
LOW OIL SWITCH .....	58
THROTTLE POSITION SENSOR .....	59
CRANKSHAFT POSITION SENSOR .....	59
NEUTRAL SWITCH .....	59
<b>INTERNAL EMM FUNCTIONS .....</b>	<b>60</b>
<b>ENGINE MONITOR SYSTEM .....</b>	<b>61</b>
<b>S.A.F.E. WARNING SYSTEM .....</b>	<b>62</b>
<b>SHUTDOWN MODE .....</b>	<b>62</b>
<b>DIAGNOSTIC SOFTWARE FUNCTIONS .....</b>	<b>63</b>
COMMUNICATION .....	63
STATIC INFORMATION .....	64
DYNAMIC INFORMATION .....	64
STORED SERVICE CODES (FAULTS) .....	65
HARD FAULTS .....	65
PERSISTENT FAULTS .....	65
STATIC TESTS .....	65
DYNAMIC TESTS .....	66
OIL CONTROL SETTINGS .....	66
TILLER/REMOTE PROGRAMMING .....	67
IGNITION TIMING .....	67
TPS CALIBRATION .....	68
IDLE SPEED CONTROL .....	68
FUEL INJECTOR SERVICING .....	68
REPORTS .....	69
SOFTWARE REPLACEMENT .....	69
<i>EMM</i> TRANSFER .....	70
<b>EMM SERVICING .....</b>	<b>70</b>
REMOVAL .....	70
INSTALLATION .....	71

## ENGINE MANAGEMENT MODULE (EMM)

### DESCRIPTION

## DESCRIPTION

The Engine Management Module (*EMM*) is a water-cooled engine controller. It controls many outboard systems including alternator output for the 12 V and 55 V circuits. Operating voltage is supplied to the *EMM* by the stator.

This section discusses the functions of the *EMM* and its various internal and external sensors. It also describes using *Evinrude Diagnostics* software to retrieve and adjust service information stored in the *EMM*.

### EMM Functions

The *EMM* controls the following processes and functions:

- Alternator output; 55 V and 12 V
- Fuel and ignition timing and duration
- Fuel injector activation
- Oil injector pump activation
- Electric fuel pump control
- Idle speed control
- RPM limiter
- Electrical circuit monitoring
- Service code creation and storage
- Warning system activation
- ROM verification, self-test
- Choke-less cold starting
- Output of diagnostic data
- Tachometer signal
- RPM profile and engine hours
- Oiling ratios
- Exhaust water valve activation (60 - 65 HP)

### EMM Connections

**IMPORTANT:** *EMM* connections and wiring must be clean and tight. Improper electrical connections can damage the *EMM*. DO NOT run the outboard with loose or disconnected wiring.

Make sure *EMM* connections are clean and tight.

- Engine wire harness to *EMM* connectors; J1-A, J1-B, J2
- Stator to *EMM* connections; one 6-pin AMP and J2 connector.

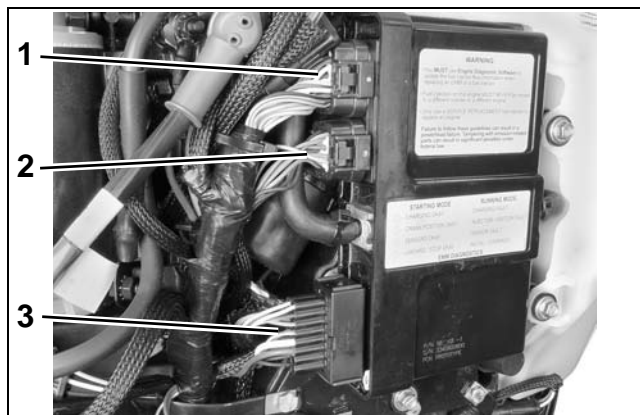

1. J1-A connector
2. J1-B connector
3. J2 connector

006487

### LED Indicators

The *EMM* has four LED indicators located next to the electrical connectors that provide useful information about the status of the system.

**IMPORTANT:** LED 1 is toward the top of the outboard (Closest to *EMM* J1-B connector).

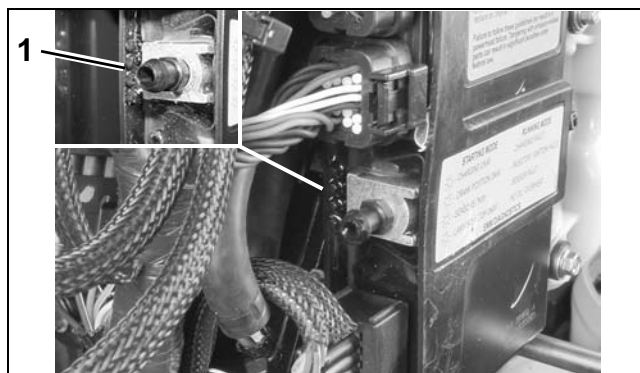

1. LED indicators  
(Cooling hose removed for clarity)

002429

006467

When the ignition key is turned ON, LEDs 3 and 4 should light, indicating that sensor circuits and the stop circuit are working.

As the outboard is being started, all four LEDs should light and then go off in sequence. If any of the LEDs does NOT light during starting, refer to **EMM LED INDICATORS** on p. 77.

When the outboard is running, all LEDs should be off. If any LED is lighted while the outboard is running, refer to **EMM LED INDICATORS** on p. 77.

# EMM INPUTS AND OUTPUTS DIAGRAM

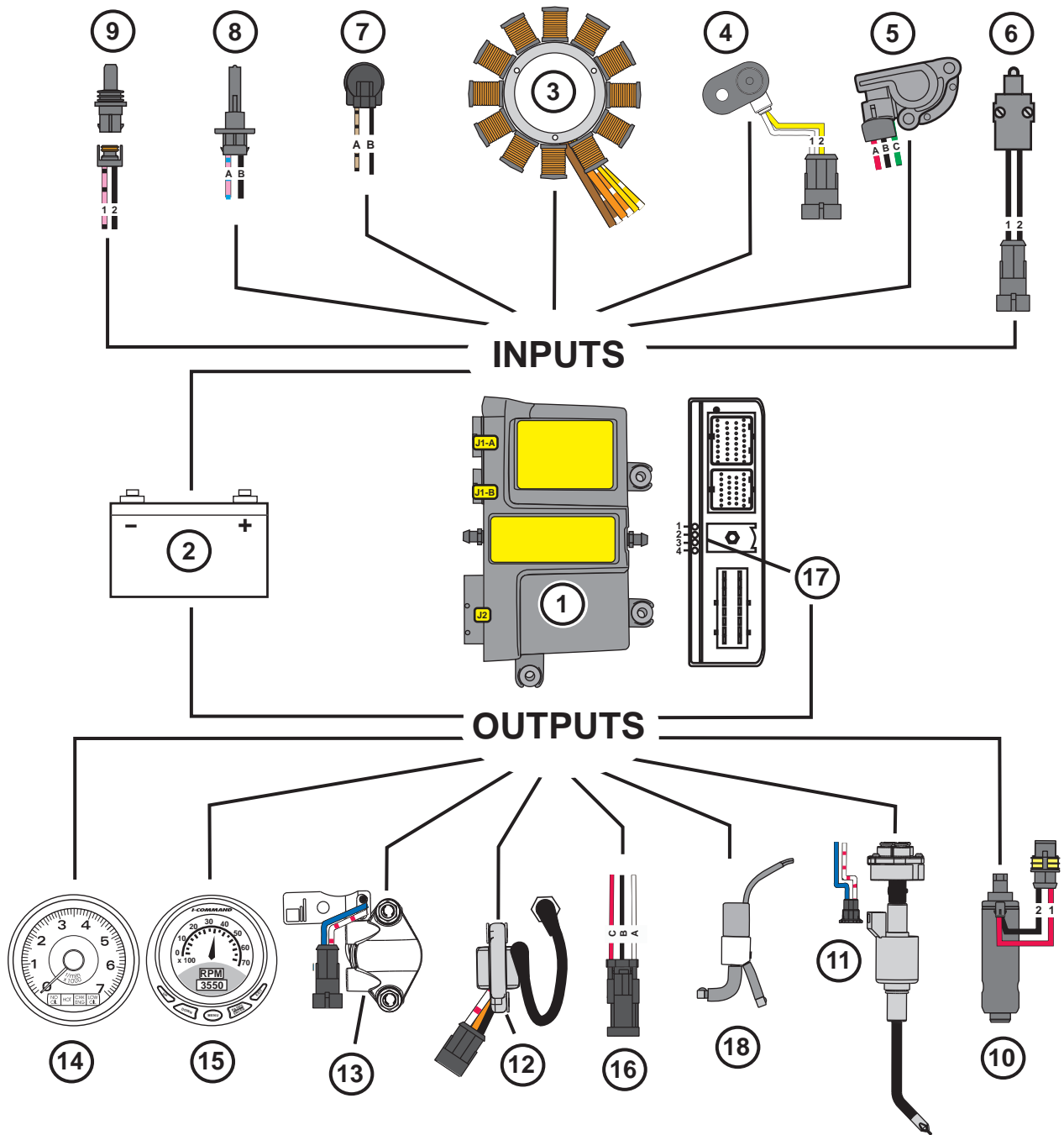

4

- 1. Engine Management Module (EMM)
- 2. Battery (12 volt)
- 3. Stator
- 4. Crankshaft Position Sensor (CPS)
- 5. Throttle Position Sensor (TPS)
- 6. Neutral Switch

- 7. Low Oil Switch
- 8. Air Temperature Sensor (AT)
- 9. Engine Temperature Sensor
- 10. Fuel Pump (high pressure)
- 11. Oil Injection Pump and Manifold
- 12. Ignition Coil

- 13. Fuel Injector
- 14. Tachometer/SystemCheck Gauge
- 15. I-Command (CANbus) Display
- 16. Diagnostic Connector
- 17. LED Indicators
- 18. Exhaust Water Valve (60–65 HP)

008026

## ENGINE MANAGEMENT MODULE (EMM)

### INTERNAL SENSORS

## INTERNAL SENSORS

Sensor inputs and internal *EMM* controllers are used to control outboard operation. Use *Evinrude Diagnostics* software to troubleshoot the sensors. Refer to the **EMM Service Code Chart** at the back of this manual for a complete list of all engine fault codes.

Internal sensors are NOT serviceable. Reprogramming or replacement may be required to resolve internal *EMM* issues.

### EMM Temperature Sensor

Monitors the temperature of the fuel injector driver circuits.

If the *EMM* temperature exceeds 176°F (80°C) or the circuit fails, the *EMM*:

Activates <i>S.A.F.E.</i>
Stores service code 25
<i>EMM</i> LED 4: ON (Running)
Engine Monitor TEMP display: ON

If *EMM* temperature exceeds 212°F (100°C) or the circuit fails, the *EMM*:

Activates SHUTDOWN
Stores service code 29
<i>EMM</i> LED 4: FLASHING
Engine Monitor TEMP display: FLASHING

**IMPORTANT:** The outboard will not restart until the engine cools below 212°F (100°C) and the *EMM* temperature returns to normal. Refer to **SHUTDOWN MODE** on p. 62.

If *EMM* temperature is less than -22°F (-30°C) or the circuit fails, the *EMM*:

Stores service code 24
<i>EMM</i> LED 3: OFF (Cranking)
<i>EMM</i> LED 3: ON (Running)

If sensor reads less than -71°F (-57.4°C) or greater than 313°F (156°C), a sensor circuit fault is detected and the *EMM*:

Stores service code 23
<i>EMM</i> LED 3: OFF (Cranking)
<i>EMM</i> LED 3: ON (Running)

### 55 V Circuit Sensor

Monitors the *EMM*'s 55 V alternator circuit.

If system voltage exceeds 57 volts, the *EMM*:

Activates <i>S.A.F.E.</i>
Stores service code 18
<i>EMM</i> LED 1: ON (Running)
Engine Monitor CHECK ENGINE display: ON

If system voltage is less than 45 V, the *EMM*:

Activates <i>S.A.F.E.</i>
Stores service code 17
<i>EMM</i> LED 1: ON (Running)
Engine Monitor CHECK ENGINE display: ON

### 12 V Circuit Sensor

Monitors the *EMM*'s 12 V alternator circuit.

If battery voltage exceeds 15.5 volts, the *EMM*:

Stores service code 27
<i>EMM</i> LED 1: ON (Running)
Engine Monitor LOW BATTERY display: ON

If battery voltage is less than 12.5 V, the *EMM*:

Stores service code 26
<i>EMM</i> LED 1: ON (Running)
Engine Monitor LOW BATTERY display: ON

## 5 V Circuit Sensor

Monitors the *EMM*'s 5 V sensor circuit.

If sensor voltage is less than 4.75 volts, the *EMM*:

Stores service code 78
<i>EMM</i> LED 3: OFF (Cranking)
<i>EMM</i> LED 3: ON (Running)

## Barometric Pressure Sensor

Supplies the *EMM* with barometric pressure reading to compensate for changes in altitude and air density.

If the BP sensor reads less than 13.3 KPa or greater than 119.0 KPa, or the sensor or circuit fails, the *EMM*:

Stores service code 44
------------------------

If the BP sensor reads less than 70 KPa, the *EMM*:

Stores a service code 45
--------------------------

If the BP sensor reads greater than 105 KPa, the *EMM*:

Stores service code 46
------------------------

## EXTERNAL SENSORS

Sensor inputs and internal *EMM* controllers are used to control outboard operation. Use *Evinrude Diagnostics* software to troubleshoot the sensors. Refer to the ***EMM Service Code Chart*** at the back of this manual for a complete list of all engine fault codes.

The *EMM* provides a 5 V DC signal for sensor circuits. It monitors all sensor voltage inputs and compares them to predetermined acceptable ranges. Inputs that fall outside of the acceptable range create service codes.

### Air Temperature Sensor

The air temperature sensor monitors the air temperature at the throttle body.

If the AT sensor voltage is out of the expected range, or the sensor or circuit fails, the *EMM*:

Stores service code 47, 48, or 49
<i>EMM</i> LED 3: OFF (Cranking)
<i>EMM</i> LED 3: ON (Running)

### Engine Temperature Sensor

Monitors cylinder head temperature.

#### 75 - 90 HP MODELS

If cylinder head temperature exceeds 212° F (100° C) below 3500 RPM, the *EMM*:

Activates <i>S.A.F.E.</i>
Stores service code 40
<i>EMM</i> LED 4: ON (Running)
Engine Monitor TEMP display: ON

If cylinder head temperature exceeds 194° F (90° C) above 3500 RPM, the *EMM*:

Activates <i>S.A.F.E.</i>
Stores service code 43
<i>EMM</i> LED 4: ON (Running)
Engine Monitor TEMP display: ON

## ENGINE MANAGEMENT MODULE (EMM)

### EXTERNAL SENSORS

If cylinder head temperature exceeds 212° F (100° C) above 3500 RPM, or 230° F (110° C) below 3500 RPM, the *EMM*:

Activates SHUTDOWN
Stores service code 31
<i>EMM</i> LED 4: FLASHING
Engine Monitor TEMP display: FLASHING

#### 40 - 65 HP MODELS

If cylinder head temperature exceeds 212° F (100° C), the *EMM*:

Activates <i>S.A.F.E.</i>
Stores service code 43
<i>EMM</i> LED 4: ON (Running)
Engine Monitor TEMP display: ON

If cylinder head temperature exceeds 248°F (120°C), the *EMM*:

Activates SHUTDOWN
Stores service code 31
<i>EMM</i> LED 4: FLASHING
Engine Monitor TEMP display: FLASHING

#### ALL MODELS

The outboard will not restart after a temperature related SHUTDOWN until the engine temperature returns to normal. Refer to **SHUTDOWN MODE** on p. 62.

If sensor values are less than -15°F (-26.1°C) or greater than 332°F (166.5°C), the *EMM*:

Stores service code 41
<i>EMM</i> LED 3: OFF (Cranking)
<i>EMM</i> LED 3: ON (Running)

If sensor values are below -4°F (-20°C), the *EMM*:

Stores service code 42
<i>EMM</i> LED 3: OFF (Cranking)
<i>EMM</i> LED 3: ON (Running)

If cylinder head does not reach operating temperature (104°F / 40°C below 2300 RPM) in 10 minutes, the *EMM*:

Stores service code 58
<i>EMM</i> LED 3: OFF (Cranking)
<i>EMM</i> LED 3: ON (Running)

#### Low Oil Switch

The low oil switch monitors the oil level in the oil tank.

If the oil level falls below one-quarter capacity, the *EMM* signals:

Engine Monitor LOW OIL display: ON
------------------------------------

When the oil level falls below one-quarter, the *EMM* begins counting oil pump pulse cycles. When it reaches:

- **40 – 65 HP:** 4800 pulses
- **75 – 90 HP:** 6000 pulses

the *EMM*:

Activates <i>S.A.F.E.</i>
Stores service code 117
<i>EMM</i> LED 4: ON (Running)
Engine Monitor NO OIL display: ON

To recover from *S.A.F.E.* mode, the oil pump must cycle for a minimum of three pulses with the oil level above one-quarter.

If outboard has been run for more than 3 hours with NO OIL faults (codes 34 & 117), the *EMM*

Activates SHUTDOWN
Stores service code 33
<i>EMM</i> LED 4: FLASHING
Engine Monitor NO OIL display: FLASHING

## Throttle Position Sensor

The throttle position sensor receives a voltage signal from the *EMM*. As the throttle lever is rotated, the *EMM* receives a return voltage signal through a second wire. This signal increases as the TPS lever is advanced. A third wire provides a ground circuit back to the *EMM*.

If TPS voltage is greater than 0.78 volts when the key is turned to ON, or the recoil starter is pulled, the *EMM*:

Creates service code 11
-------------------------

If the outboard starts, the code is stored.

If code 11 is present as both a Hard Fault and a Stored Fault, refer to **Control Cable Installation** on p. 19. For tiller models, refer to **Throttle Cable Adjustment** on p. 276, or **Throttle Cable Adjustment** on p. 287.

If the TPS or TPS circuit fails (below 0.14 volts or above 4.92 volts), the *EMM*:

Stores service code 12
Limits engine RPM to IDLE
<i>EMM</i> LED 3: OFF (Cranking)
<i>EMM</i> LED 3: ON (Running)
Engine Monitor CHECK ENGINE display: ON

**IMPORTANT:** When a TPS circuit fault has been detected, the outboard will not accelerate above idle speed. To reset, stop the outboard and correct the fault.

If the TPS circuit reads below 0.2 volts, the *EMM*:

Stores service code 13
<i>EMM</i> LED 3: OFF (Cranking)
<i>EMM</i> LED 3: ON (Running)
Engine Monitor CHECK ENGINE display: ON

If the TPS circuit reads above 4.85 volts, the *EMM*:

Stores service code 14
<i>EMM</i> LED 3: OFF (Cranking)
<i>EMM</i> LED 3: ON (Running)
Engine Monitor CHECK ENGINE display: ON

## Crankshaft Position Sensor

Ribs spaced on the flywheel mark crankshaft position. As the ribs pass the magnetic field of the CPS, an AC voltage signal is generated. The *EMM* uses this signal to identify crankshaft position and speed, generate a tachometer signal, and control fuel and ignition timing.

If the sensor is damaged or the signal is intermittent (10 occurrences), the *EMM*:

Stores service code 16
<i>EMM</i> LED 2: OFF (Cranking)
<i>EMM</i> LED 3: ON (Running)

Approximate air gap between CPS and flywheel encoder ribs is 0.073 inch (1.85 mm).

Use the *Evinrude Diagnostics* software *Monitor* screen to check CPS operation. The software should show an RPM reading while the outboard is cranking. If the CPS or its circuit fails, no RPM reading will appear and the outboard cannot run.

## Neutral Switch

The powerhead mounted neutral switch controls a ground signal from the *EMM* to indicate shift linkage position. This allows the *EMM* to control idle speed variations and start in gear protection. Fuel and ignition functions are turned off if the neutral switch is not closed.

If the starter is cranked while the outboard is in gear, or if the switch fails, the *EMM*:

Stores service code 19
<i>EMM</i> LED 3: OFF (Cranking)
Engine Monitor CHECK ENGINE display: ON

The *Monitor* screen of the diagnostics software displays switch position, NEUTRAL or IN GEAR. Make sure switch is operating properly.

## **INTERNAL *EMM* FUNCTIONS**

### **ROM Verification**

The *EMM* performs a self-test of programming every time it is turned ON. Service code 15 indicates a programming (software) issue. Reprogram the *EMM* with the correct software program to correct the problem.

### **Idle Controller**

The idle controller reacts to engine operating conditions. Fuel and ignition timings are altered to maintain a specific RPM when engine is cold or warm. The controller is inactive when TPS is advanced from idle position.

### **RPM Limiter**

This feature of *EMM* programming prevents engine damage due to excessive RPM. At 6250 RPM, fuel and ignition to the cylinders is shut off. Normal operation resumes when engine RPM returns to the specified range.

### **Neutral RPM Limiter**

This feature prevents engine damage due to excessive RPM if accelerated in NEUTRAL. Neutral engine speed is limited to 1800 RPM.

### **Exhaust Water Valve Activation (60 - 65 HP)**

During acceleration, the *EMM* opens a valve that injects water into the exhaust housing. This water changes the tuning of the exhaust, allowing the engine to develop more midrange horsepower as the boat comes on plane.

Two conditions must be met to activate the valve:

- Throttle opening above 80%
- RPM between 2500 to 4600.

The valve may not activate if the engine is accelerated slowly.

### **Engine Monitor and Warning Systems**

Refer to **ENGINE MONITOR SYSTEM** on p. 61.

Refer to **S.A.F.E. WARNING SYSTEM** on p. 62.

Refer to **SHUTDOWN MODE** on p. 62.

### **Fault Code Creation and Storage**

Refer to the ***EMM* Service Code Chart** at the back of this manual for a complete list of all engine fault codes.



## ENGINE MONITOR SYSTEM

All remote controlled outboards must be equipped with an engine monitoring system to warn the operator of conditions that could damage the outboard.

The engine monitor system includes sensors on the outboard and oil tank, a warning horn, a dash-mounted display, and related wiring.

The outboard's *EMM* sends information about monitored functions to:

- *SystemCheck* gauges
- An *I-Command* or *ICON* display
- *EMM* LED indicators.

**IMPORTANT:** Operating the outboard without an engine monitor will void the warranty for failures related to monitored functions. For information about boat mounted Information Display System options, refer to the current **Predelivery and Installation Guide** included with the service manual set.



Typical *I-Command* and *SystemCheck* gauges

007988

The *EMM* activates the warning horn and gauge displays as follows:

- **LOW OIL** means that oil in the tank is at reserve level (about 1/4 full).
- **NO OIL** indicates the oil tank is empty.
- **WATER TEMP** or **HOT** indicates an engine or *EMM* overheat condition.
- **CHECK ENGINE** or **FAULT** is used to indicate other fault conditions identified by the *EMM*.

Refer to the ***EMM* Service Code Chart** at the back of this manual for a complete list of all fault codes.

### System Self-Test

During engine start-up, pause with the key switch in the ON position. The horn self-tests by sounding a half-second beep. *SystemCheck* gauges self-test by turning the indicator lights on simultaneously, then off in sequence.

**Note:** The warning horn does NOT sound in an *I-Command* installation.

### Service Mode

*SystemCheck* goes into a service mode if the key is left ON after self-test (engine NOT running). All light circuits and sensors are active, but the horn is not. Grounding the appropriate light circuit wire will turn the light on, but the horn will not sound. Refer to **SystemCheck CIRCUIT TESTS** on p. 107.

### Engine Running

All warning circuits are active when the engine is running. The horn circuit is active when engine speed exceeds 500 RPM.

Engine monitor warnings activate the horn for 10 seconds and the appropriate gauge light for a minimum of 30 seconds. If the failure is momentary (for example, oil moving in the tank), the light will remain ON for the full 30 seconds before going out. If the fault continues, the light remains ON until the key is turned OFF or the failure is corrected. The warning will reoccur at the next start-up if the problem is not corrected.

## ENGINE MANAGEMENT MODULE (EMM)

### S.A.F.E. WARNING SYSTEM

## S.A.F.E. WARNING SYSTEM

The *S.A.F.E.* (*Speed Adjusting Failsafe Electronics*) warning system alerts the operator and protects against engine damage from the following abnormal conditions:

Code 17	Alternator 55 V below expected range
Code 18	Alternator 55 V above expected range
Code 25	<i>EMM</i> temperature above expected range
Code 34	Oil injector open circuit
Code 40	Cylinder head temperature above expected range—low speed
Code 43	Cylinder head temperature above expected range—high speed
Code 117	NO OIL detected

### Activation

When one of these conditions occurs, the *EMM* interrupts fuel injector and ignition operation, reducing engine speed to 1200 RPM. The warning horn sounds and an Engine Monitor message displays. When *S.A.F.E.* is active, the engine will run normally below 1200 RPM. Above 1200 RPM, the engine will shake excessively.

### Recovery

The engine will operate in *S.A.F.E.* as long as the fault condition exists. To recover normal operation, two conditions must be met:

- Sensor or switch readings must be back within limits
- The *EMM* must be reset—stop and restart

## SHUTDOWN MODE

Outboard “shutdown” will occur if specific faults are detected by the *EMM*:

Code 29	Excessive <i>EMM</i> temperature
Code 31	Excessive engine temperature
Code 33	Excessive NO OIL condition
Code 57	High RPM with low TPS setting

Code 57 occurs when the *EMM* detects abnormally high RPM relative to the TPS position. This condition could be caused by uncontrolled fuel entering the combustion cycle. Before removing the code and STARTING the outboard, find and repair the cause.

- Perform **Fuel System Pressure Test** on p. 137. Check for external fuel leakage that could allow fuel and/or vapor to enter the engine through the air intake.
- Check for internal fuel leakage from a leaking injector or vapor separator vent hose.

### WARNING

**If the engine shuts OFF and the “CHECK ENGINE” light or *EMM* SENSOR FAULT LED is flashing, the engine cannot be restarted. A hazardous fuel condition may exist which could result in a fire or explosion.**

### Recovery

To recover from shutdown mode, the *EMM* must NOT detect the related fault at start-up. The outboard will not restart until the cause of the stored service code is resolved (code 29 and 31) and the code is cleared using diagnostics software (code 33 and 57). Then, the *EMM* must be turned OFF and ON again.

**IMPORTANT:** Shutdown related to code 57 or 33 requires the removal of the stored service code. Use *Evinrude Diagnostics* software to clear a code 57 or 33.

# DIAGNOSTIC SOFTWARE FUNCTIONS

The *EMM* stores valuable information about the outboard and its running history. This information can be used for troubleshooting, for checking parts information, and for making adjustments to the system.

Use *Evinrude Diagnostics* software, version 4.5 or higher, and a laptop computer to access program information.

**IMPORTANT:** For software help, refer to the “Help” menu in the software.

## Communication

Locate the diagnostic connector on the engine. Remove the cover and install the Diagnostic Interface Cable (P/N 437955).

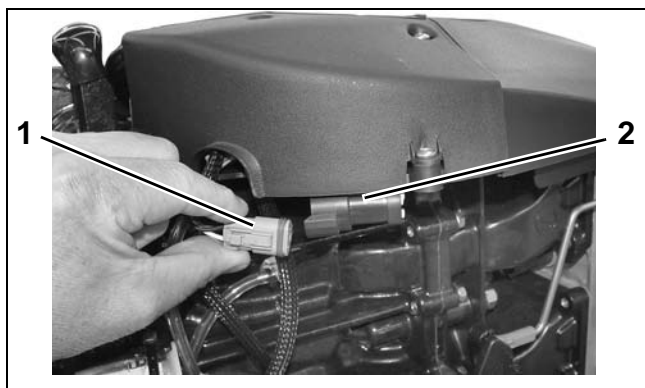

1. Diagnostic connector 004973  
2. Cover

Connect the 9-pin connector of the interface cable directly to the computer’s serial port.

The *EMM* must turn ON before it will communicate with the computer.

## ELECTRIC START MODELS

Power is normally supplied to the *EMM* when the key switch is ON. Switched B+ (12 V) enters the *EMM* at pin 28 (purple) of the *EMM* J1-B connector.

The *EMM* is also turned ON when it begins to receive AC voltage from the stator while the outboard is being cranked.

## ROPE START MODELS

Diagnostic communications on non-running rope start models requires a power supply to the *EMM*.

Use Diagnostic Power Supply Tool, P/N 587005, to supply power to the *EMM*. The power supply uses internal 9-volt batteries.

Disconnect the tiller handle harness connector from the engine harness. Connect Power Supply Tool to the engine harness connector. Turn toggle switch to the ON position to power the *EMM*.



1. Power supply tool 007279  
2. Engine harness connectors

**IMPORTANT:** Static tests require more power than the internal batteries of the tool can provide. Static tests performed using only the internal power supply batteries will produce false results.

Use Accessory Power Cable Kit, P/N 5008092, to connect an external 12 volt battery to the Power Supply Tool when performing these static tests:

- Fuel pump
- Fuel injector
- Ignition coil
- Oil injector



1. External power connector 007280

# ENGINE MANAGEMENT MODULE (EMM) DIAGNOSTIC SOFTWARE FUNCTIONS

If Diagnostic Power Supply Tool, P/N 587005, is not available, a Battery Cable, P/N 584348, can be connected to the engine mounted solenoid. Use accessory Key Switch Assembly, P/N 176408, to control power to the *EMM*.

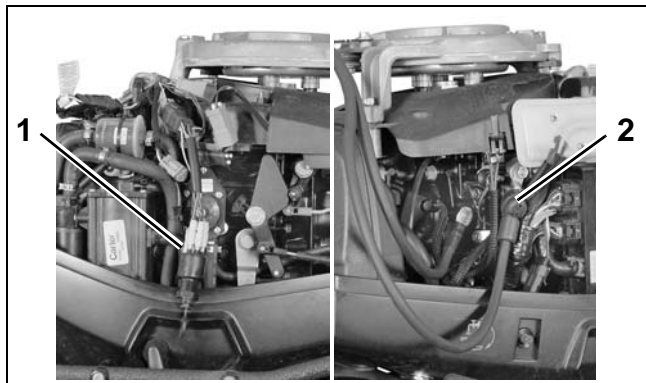

1. Accessory key switch
2. Battery cable

007281  
007282

## Static Information

Static information is viewed when the outboard is NOT running. This includes manufacturing information.

The outboard model and serial numbers displayed on the *Identity* screen must match the identification label on the outboard swivel bracket.

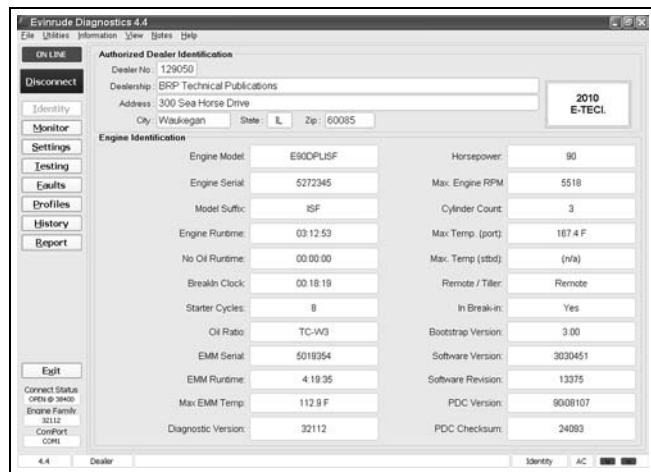

Identity Screen

008078

The serial number and cylinder location displayed on the *Injector Coefficients* screen must match the actual cylinder placement for each injector.

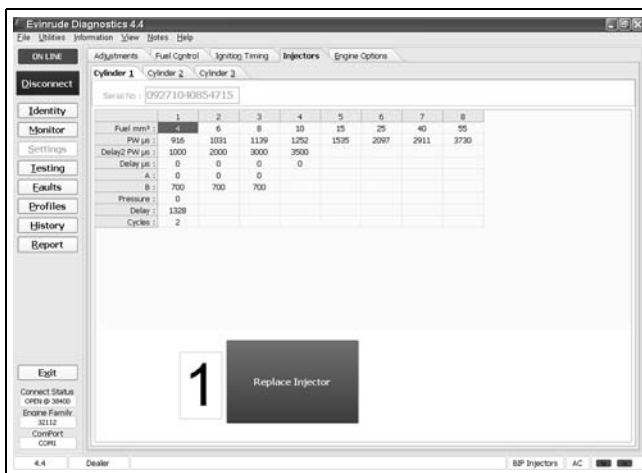

Injector Coefficients Screen

008079

## Dynamic Information

Dynamic information is viewed while the outboard is running. Changes in data, such as voltages or temperatures, are shown as they happen.

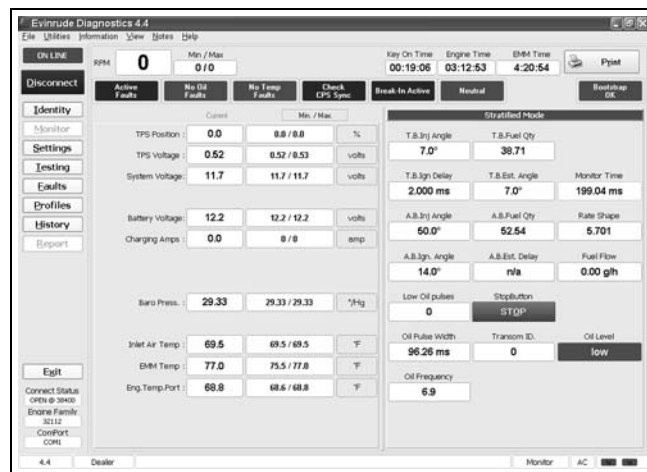

Monitor Screen

008080

## Stored Service Codes (Faults)

Service codes are stored if an abnormal condition occurs while the outboard is running.

The *Stored Faults* screen of the diagnostics software shows the code number, the number of times the event occurred, and operating hours of first and last occurrences.



Stored Faults Review Screen

008098

## Hard Faults

A hard fault is a service code that currently exists. Hard faults become stored faults only if the outboard is running.



Hard Faults Review Screen

008081

## Persistent Faults

The *Persistent Faults* screen keeps a history of all previously stored codes, including code number, the number of times the event occurred, and operating hours of the last occurrence.

Persistent faults cannot be erased.

## Static Tests

Static Tests allow diagnostic testing of system components while the outboard is NOT running.

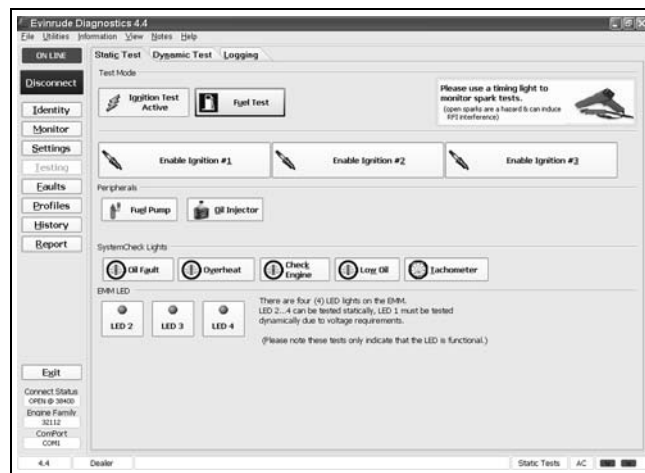

Static Tests Screen

008082

## Ignition Test

Use the diagnostics software to test each ignition circuit. Refer to **Static Ignition Test** on p. 81.

## Fuel Test

Use the diagnostics software to test each fuel injector circuit. Refer to **Fuel Injector Static Test** on p. 84.

## Oil Injector

Use the diagnostics software to test the oil injection pump circuit. Refer to **OILING SYSTEM TESTS** on p. 166.

## Fuel Pump

Use the diagnostics software to test the fuel pump circuit. Refer to **Fuel Pump Static Test** on p. 84.

## Water Injector

This test activates the exhaust water valve solenoid (60 - 65 HP). Refer to **Exhaust Water Valve Static Test** on p. 86.

# ENGINE MANAGEMENT MODULE (EMM) DIAGNOSTIC SOFTWARE FUNCTIONS

## Overheat

This test is used to check the “ENG TEMP” or “HOT” circuit of the Engine Monitoring system.

## Oil Fault

This test is used to check the “NO OIL” circuit of the Engine Monitoring system.

## Check Engine

This test is used to check the “CHECK ENGINE” circuit of the Engine Monitoring system.

## Tachometer

This test is used to check operation of the tachometer circuit.

## Dynamic Tests

Dynamic tests are performed with the outboard running.



Dynamic Tests Screen

008083

## Ignition Test

This test momentarily disables the ignition and fuel injection circuits to one cylinder. By dropping one cylinder, RPM and running quality changes can be observed. Refer to **DYNAMIC TESTS** on p. 76.

## Fuel Test

This test momentarily disables one fuel injector circuit. By dropping one cylinder, RPM and running quality changes can be observed. Refer to **DYNAMIC TESTS** on p. 76.

## Prime Oil

This test is used to cycle the oil injection pump for priming the oiling system. Perform this test with outboard running to activate oil injection pump.

## Oil Control Settings

### Set Oil Type

The TC-W3 oil type setting is the standard setting for all outboards. Set TC-W3 for:

- Operation with all TC-W3 outboard oils including *XD30*, *XD50*, or *XD100*
- Applications requiring maximum lubrication
- Extreme applications (racing or harsh conditions).

The *XD100* setting provides an option to run the outboard at a reduced oil injection rate. This setting **REQUIRES** the use of *Evinrude XD100* outboard lubricant and is not recommended for all applications.

Use the *XD100* setting for:

- Conventional use (runabouts, cruisers)
- Moderate applications.

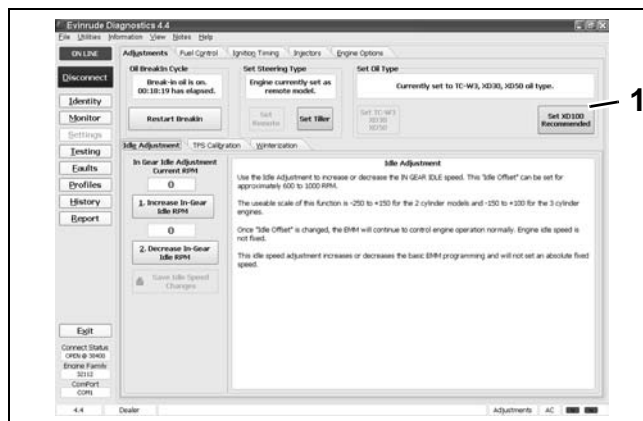

1. Oil control setting

008084



## CAUTION

**Running an Evinrude E-TEC outboard on other grades of oil while set to the XD100 oil ratio will result in increased engine wear and shortened outboard life.**

## Powerhead Break-In

Use the diagnostics software to start break-in oiling after a powerhead rebuild. The break-in oiling program runs for two hours of outboard operation, above 2000 RPM.

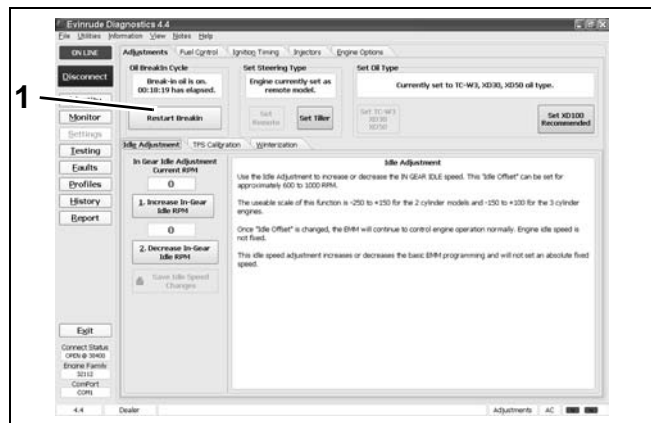

1. Break-in oil setting 008084

## Tiller/Remote Programming

This feature controls the start in gear protection function of the neutral switch. Tiller operated models, including remote models with an installed tiller conversion kit, **MUST** be set to TILLER.

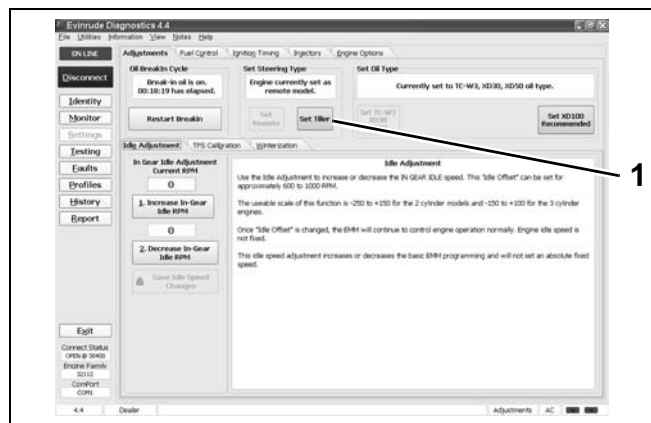

1. Starter mode setting 008084

## Ignition Timing

Use the *Ignition Timing* screen to check and adjust *EMM* timing. *EMM* timing must be synchronized to crankshaft position.

Refer to **TIMING ADJUSTMENTS** on p. 113.

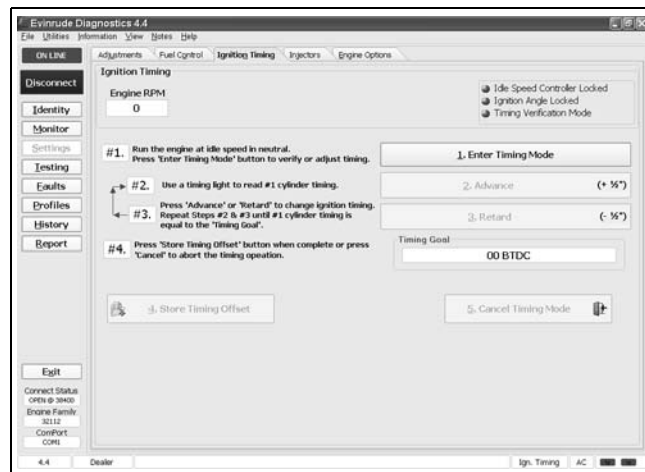

008085

Check timing after any of the following procedures:

- Powerhead replacement
- Crankshaft replacement
- Flywheel removal or replacement
- CPS replacement
- *EMM* replacement
- *EMM* software replacement

**IMPORTANT:** Make sure the timing pointer is set and the outboard reaches operating temperature before making adjustments.

4

# ENGINE MANAGEMENT MODULE (EMM) DIAGNOSTIC SOFTWARE FUNCTIONS

## TPS Calibration

TPS Calibration synchronizes throttle plate opening with throttle position sensor voltage.

Refer to **TPS Calibration** on p. 114.



1. *TPS Calibration* button 008086

Perform TPS Calibration after replacing or adjusting any throttle body or throttle linkage parts.

## Idle Speed Control

Use the *Idle Adjust* function to increase or decrease IN GEAR IDLE speed. This adjustment offsets the basic *EMM* programming and will not set an absolute fixed speed. After the offset is changed, the *EMM* continues to control engine operation normally. Engine idle speed is not fixed.

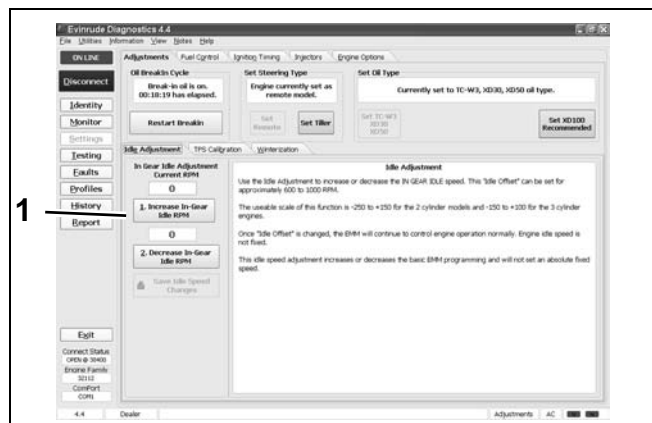

1. *Idle adjustment* 008084

## Fuel Injector Servicing

All *E-TEC* fuel injectors use software programming to compensate for variations in fuel flow. Each injector and its location on the outboard is identified by the *EMM*. DO NOT install an injector without updating the compensation software.

To install a service injector, click the “Replace” button on the *Injector Coefficients* screen and select the file for the replacement injector. Refer to **Fuel Injector Service** on p. 146.

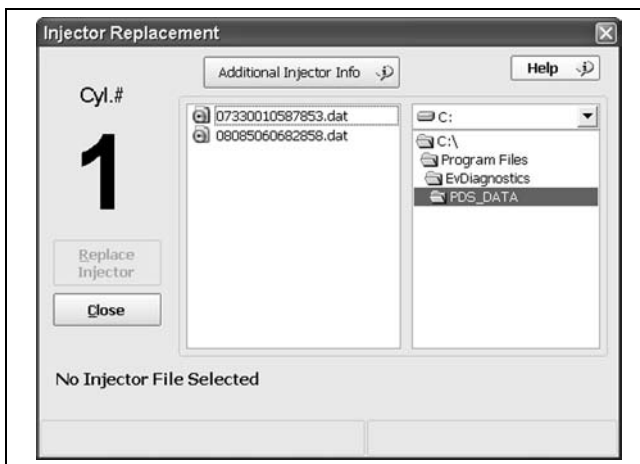

008100



# ENGINE MANAGEMENT MODULE (EMM) DIAGNOSTIC SOFTWARE FUNCTIONS

## Reports

Engine reports provide service records and can be used to document the running history of an outboard. Reviewing this information can help identify or resolve some service issues.

Click the print button in a window of the diagnostics software to print engine data, or to export the information to a computer file.

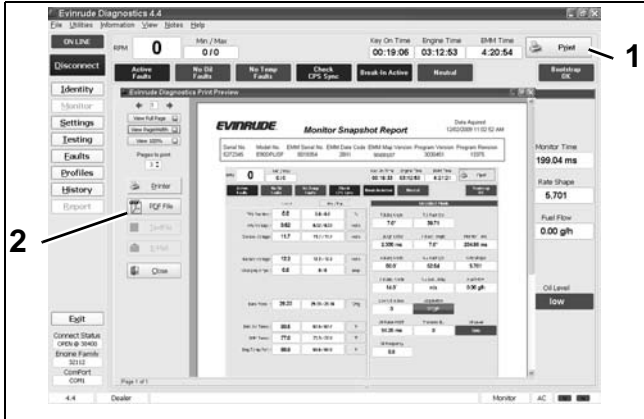

1. Print button
2. Print/Export options

008087

## Software Replacement

Engine Management Software is loaded into the *EMM* at the factory. Periodically, a new program may be available to enhance the operation of an outboard. Select *Engine Software Update* from the *Utilities* menu and refer to the instructions provided with the program.



008095

4

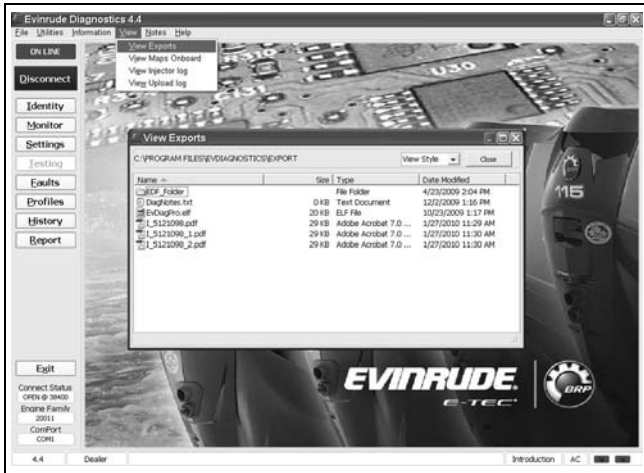

Engine Report data files

008096

**IMPORTANT:** Software replacement requires the use of Bootstrap Tool, P/N 586551. Install tool between engine and boat harness key/stop switch connectors as instructed by update program.



002383

# ENGINE MANAGEMENT MODULE (EMM) EMM SERVICING

## EMM Transfer

EMM Transfer is used to save engine history data when the EMM must be replaced.

Select *EMM Data Transfer* from the *Utilities* menu. Select the *Collect EMM data to FILE* option and follow the instructions provided with the program.

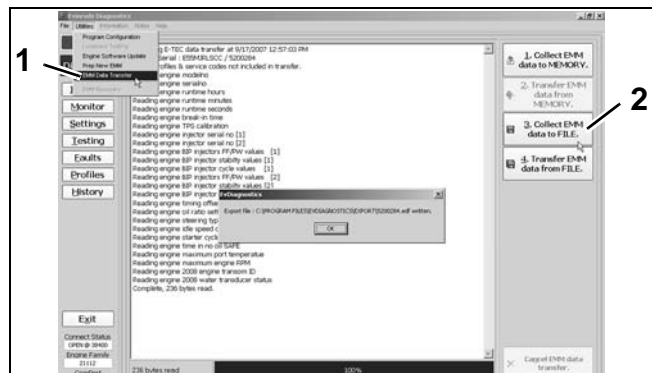

1. Select *EMM Data Transfer*
2. Select *Collect EMM data to FILE*

006642

**IMPORTANT:** Whenever the *EMM* is replaced, *EMM* timing must be synchronized to crankshaft position. Refer to **TIMING ADJUSTMENTS** on p. 113.

## EMM SERVICING

**IMPORTANT:** If a new *EMM* is being installed, refer to **EMM Transfer** on p. 70.

## Removal

Disconnect cooling hoses from *EMM*.

Disconnect J1-A, J1-B, and J2 connectors.

Remove three *EMM* retaining screws and washers. Remove *EMM*.

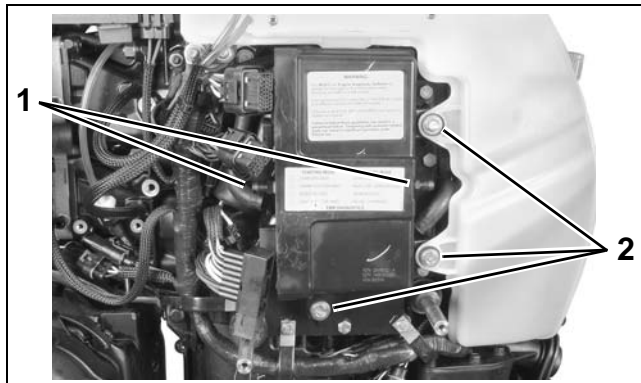

1. Cooling hose connections
2. EMM mounting screws

006476

Remove *EMM* from behind oil tank bosses.

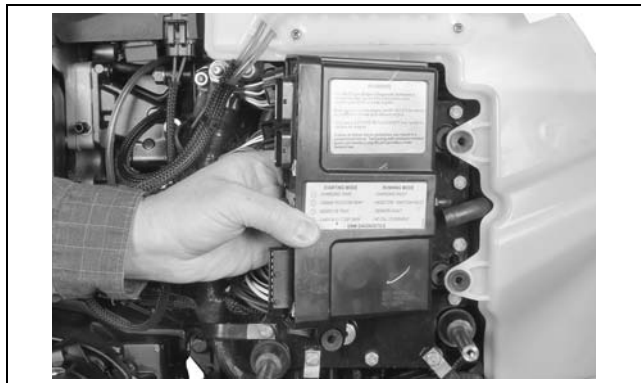

006477

## Installation

Installation is the reverse of removal. Pay close attention when performing the following tasks.

Make sure isolator mounts are placed in slots in of *EMM* case. Slide *EMM* into position.

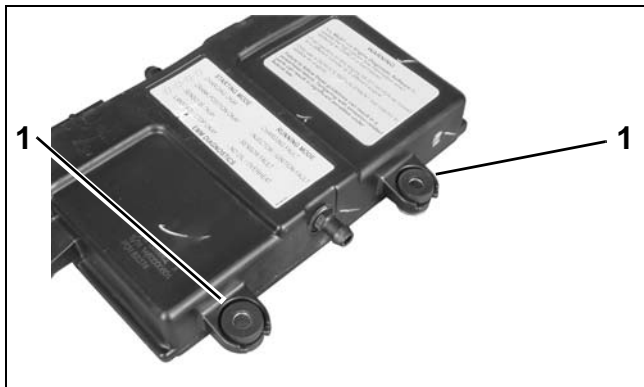

1. Isolator mounts

006478

Apply *Nut Lock* to threads of *EMM* retaining screws. Tighten to a torque of 30 to 42 in. lbs. (4 to 5 N·m).

Install harness connectors and cooling hoses. Secure hoses with tie straps.



# SYSTEM ANALYSIS

## TABLE OF CONTENTS

<b>DIAGNOSTIC PROCEDURES</b> .....	74
<b>VISUAL INSPECTIONS</b> .....	74
<b>OPERATIONAL INSPECTIONS</b> .....	74
<b>TROUBLESHOOTING</b> .....	75
<b>DYNAMIC TESTS</b> .....	76
<b>CYLINDER DROP TESTS</b> .....	76
<b>FUEL CONTROL ADJUSTMENT</b> .....	76
<b>INDUCTIVE AMP METER TEST</b> .....	76
<b>EMM LED INDICATORS</b> .....	77
<b>KEY ON</b> .....	77
<b>STARTING</b> .....	77
<b>RUNNING</b> .....	78
<b>IGNITION OUTPUT TESTS</b> .....	79
<b>REQUIRED IGNITION SYSTEMS</b> .....	79
<b>WIRING INSPECTION</b> .....	79
<b>CRANKSHAFT POSITION SENSOR (CPS) TEST</b> .....	80
<b>SYSTEM VOLTAGE TEST</b> .....	80
<b>STATIC IGNITION TEST</b> .....	81
<b>RUNNING IGNITION TESTS</b> .....	82
<b>IGNITION CONTROL CIRCUIT TESTS</b> .....	83
<b>IGNITION COIL TESTS</b> .....	83
<b>CAPACITOR TEST</b> .....	83
<b>FUEL DELIVERY TESTS</b> .....	84
<b>FUEL PUMP STATIC TEST</b> .....	84
<b>FUEL INJECTOR STATIC TEST</b> .....	84
<b>RUNNING FUEL SYSTEM TESTS</b> .....	85
<b>EXHAUST WATER VALVE (60–65 HP)</b> .....	86
<b>EXHAUST WATER VALVE STATIC TEST</b> .....	86
<b>EXHAUST WATER VALVE DYNAMIC TEST</b> .....	86

# DIAGNOSTIC PROCEDURES

## Visual Inspections

Inspect wiring and electrical connections. Disassemble and clean all corroded connections. Replace damaged wiring, connectors, or terminals. Repair any shorted electrical circuits.

- Refer to **ELECTRICAL HARNESS CONNECTIONS** on p. 92.
- Refer to **WIRING DIAGRAM** at the back of this manual.
- Refer to **CONNECTOR SERVICING** on p. 116.

Make sure all ground connections are clean and tight. Refer to **GROUND CIRCUITS** on p. 94.

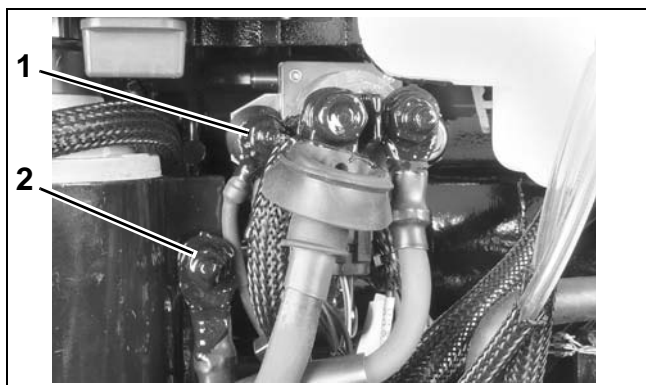

1. Main engine harness ground 002292  
 2. Ground stud (battery)

Inspect spark plugs for wear, oil fowling, or damage. A rich or lean running condition or evidence of internal engine damage could be identified by the appearance of the spark plugs.

Check the fuse and the emergency stop switch lanyard.

## Operational Inspections

Run the outboard to confirm actual symptoms before performing any unnecessary procedures. Inspection should include the following:

- Make sure the outboard can be cranked easily, with no mechanical binding.
- Check the *EMM* LED Indicators for system status information. Refer to **EMM LED INDICATORS** on p. 77.
- Check the *Evinrude Diagnostics* software *Hard Faults* and *Stored Faults* screens for current service codes. Correct any problems and clear the codes before further troubleshooting. Refer to **Stored Service Codes (Faults)** on p. 65.



**Stored Faults Review Screen** 008098

Check the diagnostics software *Profiles*, *History*, and *Persistent Faults* screens for evidence of abnormal operation.

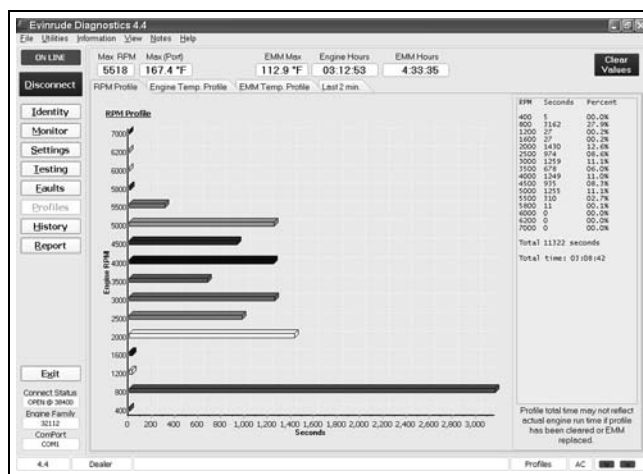

**Profiles Screen** 008088

## Troubleshooting

### Outboard will not crank, starter does not operate:

- Check condition of battery and cables (main battery switch and cables). Make sure battery cables are not reversed.
- Confirm that switched B+ is present at “A” terminal (yellow/red wire) of starter solenoid with key switch in the START position.
- Check ground at “B” terminal harness connection.
- Refer to **ELECTRIC START TESTS** on p. 102. Repair starter or start circuit as needed.

### Outboard cranks, will not start:

- Check emergency stop switch and lanyard
- Check powerhead mounted neutral switch
- Check the *EMM* LED Indicators for system status information. Refer to **EMM LED INDICATORS** on p. 77.
- Use the *Evinrude Diagnostics* software *Stored Faults* screen to check for current service codes. If there are multiple stored sensor codes, inspect all 5 V sensor circuits for broken or grounded wiring.
- Perform a Static Ignition test using *Evinrude Diagnostics* software and an inductive timing light. Refer to **Static Ignition Test** on p. 81.
- If ignition test indicates steady spark, refer to **FUEL DELIVERY TESTS** on p. 84.

### Outboard runs, low on power, misfires:

- Check the *EMM* LED Indicators for system status information. Refer to **EMM LED INDICATORS** on p. 77.
- Use the *Evinrude Diagnostics* software *Monitor* screen to check system (55 V) and TPS voltages. System voltage should be steady, and TPS voltage should be between 0.2 and 4.85 V.

**IMPORTANT:** Use a digital multimeter to check voltage on external circuits only when necessary. All *EMM* output currents are DC current.

- Use the diagnostics software *Dynamic Tests* to isolate a faulty cylinder. See **DYNAMIC TESTS** on p. 76.
- Use an inductive timing light to check ignition and fuel injector circuits. Refer to **Running Ignition Tests** on p. 82 and **Running Fuel System Tests** on p. 85.
- Use the diagnostics software *Fuel Control Adjustment* test to help identify a cylinder that may be too rich or too lean. Refer to **Fuel Control Adjustment** on p. 76.
- Use an inductive amp meter to monitor injector circuit current. Compare readings of all circuits to identify possible failure.
- Check fuel quality and that fuel is present at injectors.
- Use the diagnostics software *Logging* function to record engine data as a problem is occurring.

5

The screenshot shows the 'Logging' screen in Evinrude Diagnostics 4.4. It features a table with columns for 'RecID', 'Time (sec)', 'RPM', 'TPS (V)', 'Sprinkle', 'Sprinkle', 'Battery', 'Charge Amp', 'Eng Temp (°F)', 'Coolant Temp (°F)', 'Water Pressure', 'Fuel Flow', 'Fuel Air Ratio', 'Fuel Air Ratio', 'Fuel Air Ratio', 'Fuel Air Ratio', 'Fuel Air Ratio', 'Fuel Air Ratio', 'Fuel Air Ratio', 'Fuel Air Ratio', 'Fuel Air Ratio', 'Fuel Air Ratio'. The table contains 24 rows of data. Below the table, it shows 'Records: 24', 'Elapsed Sec: 0', 'Remaining Sec: 89', and 'Memory used: 2.6 k'. The status bar at the bottom indicates '4.4 Dealer Start a logging session. Logging AC'.

Logging Screen

008097

- AFTER all the above inspections, if the cause of a running quality problem still cannot be identified, perform a compression test to check for internal powerhead damage.

**IMPORTANT:** Remove a cylinder head or disassemble the engine only as a last resort.

## DYNAMIC TESTS

### Cylinder Drop Tests

Use the *Evinrude Diagnostics* software *Dynamic Tests* to momentarily disable one cylinder while the outboard is running.

- The Dynamic Ignition test disables the ignition and fuel injection circuits to a cylinder.
- The Dynamic Fuel test momentarily disables one fuel injector circuit.

By dropping one cylinder, RPM and running quality changes can be compared for each cylinder.

**IMPORTANT:** Test the outboard at the RPM where the problem is occurring. Use the test procedures to identify inconsistencies in voltages and cylinder performance. Once a circuit has been identified as malfunctioning, inspect all related wiring and connections. Check all voltage inputs and grounds; and perform resistance tests for all circuits before replacing any suspect components.

*Dynamic Tests* can be used with:

- A timing light to determine how other cylinders are affected by one cylinder being “dropped”; or
- A digital multimeter to check voltage changes on electrical circuits.



Dynamic Test Screen

008083

**IMPORTANT:** DO NOT misinterpret tests run at IDLE. The idle speed controller in the *EMM* compensates to maintain a constant IDLE speed. The *Dynamic Tests* screen includes a function to temporarily disable the idle controller.

### Fuel Control Adjustment

Use this test is to help identify a cylinder that may be too rich or too lean. This feature should not be used by itself to identify a faulty injector.

*Evinrude Diagnostics* software allows temporary adjustments to the fuel flow characteristics of the injectors. Factory fuel flow settings are restored when power to the *EMM* is returned to OFF.

Test the outboard at the RPM where the problem is occurring.

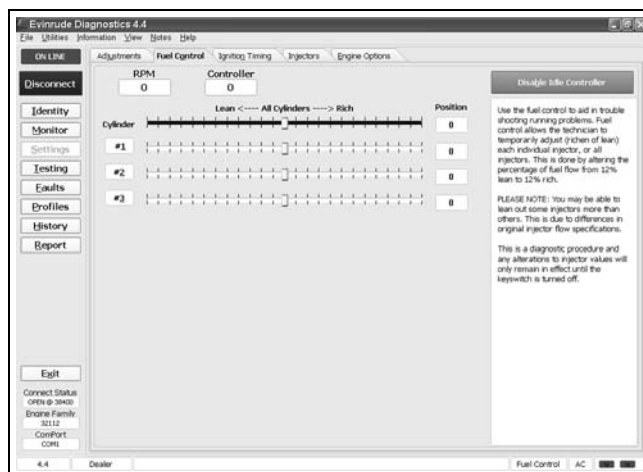

008089

If the outboard run quality improves with a fuel control adjustment, eliminate other possibilities before replacing an injector:

- Refer to **Fuel System Pressure Test** on p. 137.
- Refer to **Running Fuel System Tests** on p. 85.

**IMPORTANT:** DO NOT misinterpret tests run at IDLE. The idle speed controller in the *EMM* compensates to maintain a constant IDLE speed.

### Inductive Amp Meter Test

Use an inductive amp meter to monitor battery charging and current flow. Identifying erratic amperage in a circuit can be used to isolate a problem component.



## EMM LED INDICATORS

The *EMM* LED indicators provide a quick reference to the status of several outboard systems. Checking the LEDs **FIRST** when diagnosing an engine problem can save time.

For detailed code information, refer to the **EMM Service Code Chart** at the back of this manual.

**IMPORTANT:** LED 1 is toward the top of the outboard (closest to EMM J1-B connector).

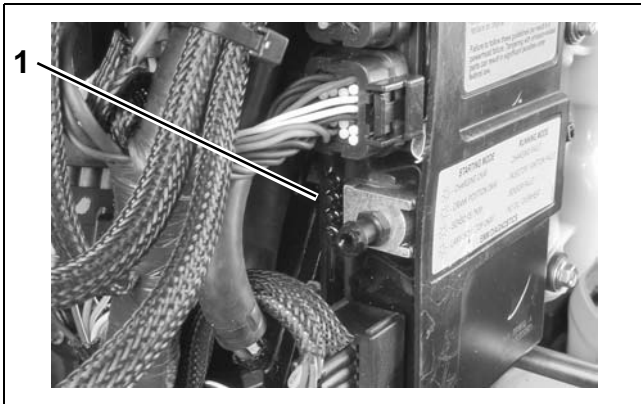

1. LED indicators

006467

### Key ON

**IMPORTANT:** Diagnostic communications on non-running rope start models requires that power is supplied to the *EMM*. Refer to **Communication** on p. 63.

When the *EMM* is ON (engine not running), the following LEDs should light:

**LED 3** – Sensor Circuits working. FLASHING LIGHT indicates Code 57 – engine will not start.

**LED 4** – Stop Circuit not grounded—okay to start. FLASHING LIGHT indicates severe overheat or no oil – engine in SHUTDOWN mode.

### Starting

Starting mode occurs from the time the flywheel begins to turn until the outboard is running for 2 seconds. During starting, all four LEDs should light and then go off in sequence.

**LED 1** – CHARGING OKAY – Stator signal 30 V or higher.

**LED 2** – CRANK POSITION OKAY – input from CPS, *EMM* powered ON. For NO LIGHT, check for:

- Code 16 – CPS, intermittent loss of sync

**LED 3** – SENSORS OKAY (5 V). For NO LIGHT, check for:

- Code 12 – TPS circuit fault
- Code 13 – TPS below expected range
- Code 14 – TPS above expected range
- Code 19 – In Gear (tiller models)
- Code 23 – *EMM* temp. sensor circuit fault
- Code 24 – *EMM* temp. below expected range
- Code 41 – temp. sensor circuit fault
- Code 42 – temp. below expected range
- Code 47 – AT sensor circuit fault
- Code 48 – AT sensor below expected range
- Code 49 – AT sensor above expected range
- Code 58 – Operating temperature not reached
- Code 78 – Sensor supply voltage fault

For FLASHING LIGHT, check for Code 57.

**LED 4** – LANYARD/STOP OKAY. For NO LIGHT, check for:

- Grounded stop circuit.

For FLASHING LIGHT, check for:

- Code 29 – *EMM* temp. OVER range (flashing)
- Code 31 – Engine temp. OVER range (flashing)
- Code 33 – Engine shutdown, excessive no oil condition

---

## SYSTEM ANALYSIS

### EMM LED INDICATORS

---

#### Running

When the outboard is running, all of the LEDs should be off. If a light is on, check for:

##### LED 1 – CHARGING FAULT:

- Code 17 – system voltage (55 V) below range
- Code 18 – system voltage (55 V) above range
- Code 26 – low battery (12 V) voltage
- Code 27 – high battery (12 V) voltage

##### LED 2 – INJECTOR/IGNITION FAULT:

- Code 51 – cylinder no. 1 injector circuit open
- Code 52 – cylinder no. 2 injector circuit open
- Code 53 – cylinder no. 3 injector circuit open
- Code 61 – cylinder no. 1 injector circuit short
- Code 62 – cylinder no. 2 injector circuit short
- Code 63 – cylinder no. 3 injector circuit short
- Code 81 – no. 1 ignition coil circuit open
- Code 82 – no. 2 ignition coil circuit open
- Code 83 – no. 3 ignition coil circuit open
- Code 90 – Water injection solenoid short
- Code 91 – fuel pump circuit open
- Code 93 – Water injection solenoid open
- Code 94 – fuel pump circuit short
- Code 101 – No. 1 ignition timing circuit shorted
- Code 102 – No. 2 ignition timing circuit shorted
- Code 103 – No. 3 ignition timing circuit shorted

##### LED 3 – Sensor circuits (5 V), SENSOR FAULT. For LIGHT ON, check for possible fault codes:

- Code 12 – TPS circuit fault
- Code 13 – TPS below expected range
- Code 14 – TPS above expected range
- Code 16 – CPS, intermittent loss of sync
- Code 23 – *EMM* temp. sensor circuit fault
- Code 24 – *EMM* temp. below expected range
- Code 41 – temp. sensor circuit fault
- Code 42 – temp. below expected range
- Code 47 – AT sensor circuit fault
- Code 48 – AT sensor below expected range
- Code 49 – AT sensor above expected range
- Code 57 – high RPM with low TPS setting
- Code 58 – operating temp. not reached
- Code 78 – Sensor supply voltage fault

##### LED 4 – Engine overheat, *EMM* temperature or sensor, oil injection pump or sensor, NO OIL / OVERHEAT. For LIGHT ON, check for possible fault codes:

- Code 25 – *EMM* overheat
- Code 29 – *EMM* overheat, critical (flashing)
- Code 31 – engine overheat, critical (flashing)
- Code 33 – excessive NO OIL faults
- Code 34 – oil injection pump circuit open
- Code 40 – engine overheat, low rpm
- Code 43 – engine overheat
- Code 117 – Critical NO OIL detected

# IGNITION OUTPUT TESTS

**⚠ DANGER**

The electrical system presents a serious shock hazard. Allow outboard to sit for two minutes after running before handling capacitor or 55 V electrical components. Failure to handle capacitor properly can result in uncontrolled electrical discharge and possible electrical shock to humans. DO NOT handle primary or secondary ignition components while outboard is running or flywheel is turning.

Use the *Evinrude Diagnostics* software *Stored Faults* screen to check for current service codes before troubleshooting. Correct any problems and clear the codes FIRST.

## Required Ignition Systems

Following is a complete list of circuits required for ignition output:

### Stop Circuit

- Black/yellow wire NOT grounded (emergency stop switch lanyard in place).

### Neutral Switch

- Powerhead mounted neutral switch provides a switched ground circuit to *EMM*. The circuit enables specialized control functions such as neutral start protection and RPM limiting in NEUTRAL.

### Stator Output Voltage

- Provides A/C voltage to *EMM* J2 connector: Outboard cranking, typical range is 20-40 VAC (AC output voltage is related to cranking RPM); Outboard running, approximately 55 VAC.

### *EMM*

- Controls ignition grounds, injector grounds, and engine timing.

### Crankshaft Position Sensor

- Provides *EMM* with input.
- Outboard cranking speed exceeds 300 RPM and a steady CPS signal is generated.

### Alternator Output/System Voltage

- System voltage from *EMM* (white/red) provides 55 VDC to the high pressure fuel pump, the oil injection pump, the fuel injectors, and the ignition coils.

### Capacitor

- Connected to 55 V circuit (white/red) to stabilize current on 55 V circuit
- Negative terminal of capacitor must be grounded.

### Ignition Coil

- Primary circuits are powered by system (55 V) voltage
- *EMM* provides control signal to ignition coil
- Output from ignition coil secondary winding and high tension spark plug wire.

## Wiring Inspection

Visually inspect all wiring, connections, and grounds.

Use a digital ohmmeter to test resistance on all ground circuits and connections. Ohmmeter readings should be approximately 0.0 W.

Check that all engine wire harness grounds have continuity to the cylinder/crankcase.

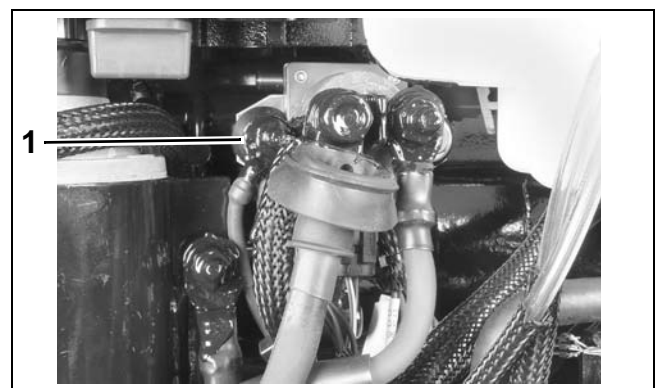

1. Main engine harness ground

002292

Clean or repair all ground circuits, wiring, and connections as needed.

# SYSTEM ANALYSIS

## IGNITION OUTPUT TESTS

### Crankshaft Position Sensor (CPS) Test

When the CPS is working properly, *EMM* LED 2 turns on while the outboard is being started.

Use the *Evinrude Diagnostics* software CPS Sync and engine RPM displays to confirm a valid CPS signal while the outboard is cranking or running. An RPM display higher than zero indicates a CPS signal to the *EMM*.

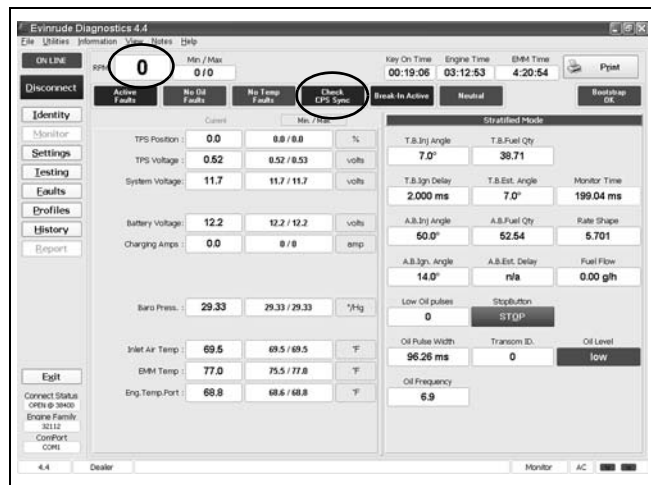

Engine RPM and CPS Sync displays 008080

If the *Monitor* screen says “Check CPS Sync,” refer to **Crankshaft Position Sensor (CPS) Test** on p. 95.

### System Voltage Test

The ignition system is powered by the 55 V system.

Use the *Evinrude Diagnostics* software *Monitor* screen to check system voltage.



Monitor Screen, System voltage 008080

#### Results:

- *EMM* ON (not running) - approximately 1 V less than battery voltage, system voltage is GOOD.
- *EMM* ON (not running) - no voltage, check 12 V power to *EMM*. Repair connection or wiring.
- RUNNING - 55 V ± 2, system voltage is GOOD.
- RUNNING - less than 55 V ± 2, check stator output to *EMM*. Repair connection or wiring. Possible faulty stator or *EMM*. Refer to **STATOR TESTS** on p. 97.

**IMPORTANT:** The *EMM* must be ON for voltage to be present on the system voltage (55 V) circuit. Power is normally supplied to the *EMM* when the key switch is turned ON. The *EMM* is also turned ON when it begins to receive AC voltage from the stator while the outboard is being cranked. On a non-running rope start engine, power is supplied to the *EMM* by Diagnostic Power Supply Tool, P/N 587005.

## Static Ignition Test

Perform the static ignition test using *Evinrude Diagnostics* software and an inductive timing light.

**IMPORTANT:** DO NOT perform static tests using Diagnostic Power Supply Tool, P/N 587005, with internal 9 volt batteries only. This will produce false results. Refer to **Communication** on p. 63.

**IMPORTANT:** DO NOT use a spark checker tool. Radio Frequency Interference (RFI) generated by the arcing current can cause erratic *EMM* operation.

The outboard must NOT be running and the emergency stop switch lanyard must be installed.

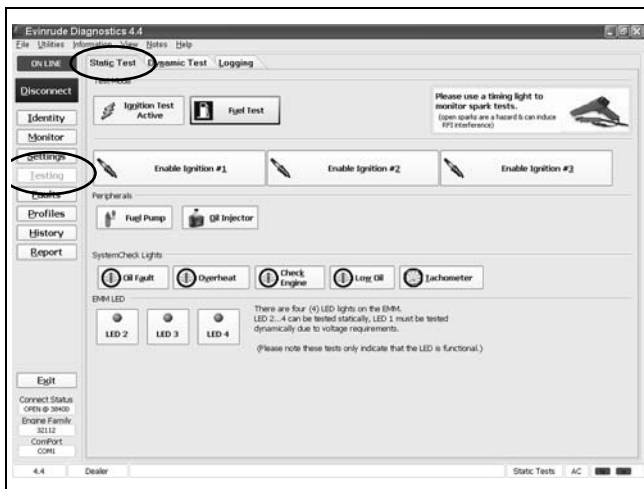

Static Tests Screen

008082

Connect timing light pickup to the secondary circuit (spark plug lead) of the cylinder being tested. Activate test and observe timing light strobe for consistent flash.

**IMPORTANT:** This test is operating the ignition coil with 12 V battery power on the system voltage (55 V) circuit. An inductive probe with low sensitivity may not be able to detect the signal.

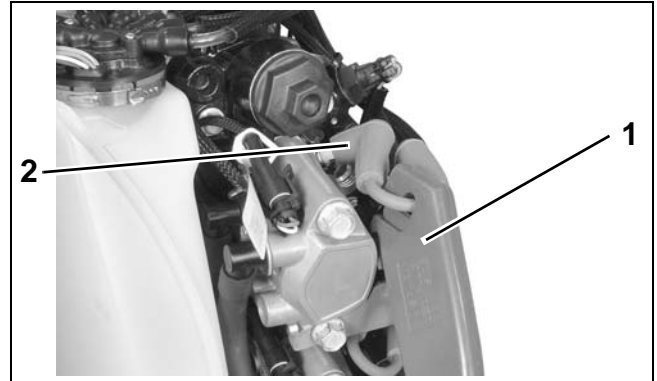

1. Timing light pick-up
2. Spark plug lead

006492

**5**

### Results:

No spark on one or more cylinders:

- Inspect or replace spark plugs
- Refer to **Ignition Control Circuit Tests** on p. 83
- Refer to **Ignition Coil Tests** on p. 83

Steady spark on all cylinders:

- Refer to **Running Ignition Tests** on p. 82 and **DYNAMIC TESTS** on p. 76.

---

## SYSTEM ANALYSIS

### IGNITION OUTPUT TESTS

---

#### Running Ignition Tests

Use *Evinrude Diagnostics* Software to monitor system voltage (55 V).

- Voltage readings at a specific speed (RPM) should be steady
- Refer to **System Voltage Test** on p. 80.

Use an inductive timing light to monitor the spark signal through each of the secondary circuit (spark plug lead) wires.

Start outboard and observe timing light strobe. Look for a consistent flash and only one flash per revolution. The strobe of the timing light should be the same for each cylinder.

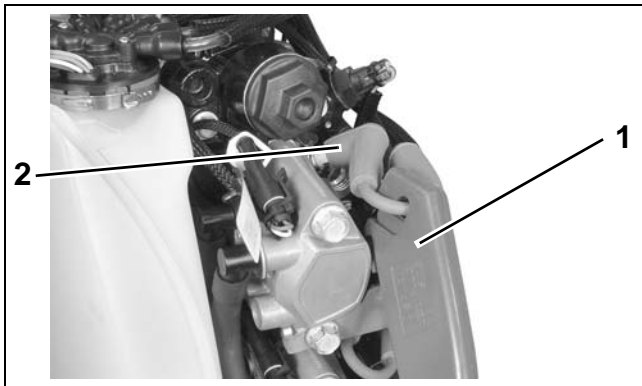

1. Timing light pick-up
2. Spark plug lead

006492

#### Results:

Steady voltage and strobe, engine misfires:

- Inspect or replace spark plugs
- Refer to **FUEL DELIVERY TESTS** on p. 84
- Check for internal engine damage.

Steady voltage, erratic strobe, engine misfires:

- Inspect or replace spark plugs
- Check CPS air gap and resistance.
- Refer to **Ignition Control Circuit Tests** on p. 83
- Refer to **Ignition Coil Tests** on p. 83.

Voltages fluctuate, engine misfires:

- Inspect battery and connections
- Test capacitor and all ground connections.
- Refer to **System Voltage Test** on p. 80
- Refer to **Ignition Control Circuit Tests** on p. 83
- Refer to **Ignition Coil Tests** on p. 83.

**IMPORTANT:** If a running problem occurs at about 1200 RPM, the outboard may be in *S.A.F.E.* Refer to **S.A.F.E. WARNING SYSTEM** on p. 62.

## Ignition Control Circuit Tests

Use a digital multimeter to test the following:

- System voltage supply to ignition coil.
- Ignition control signal from *EMM*.
- Engine harness resistance.

Disconnect ignition coil connector.

### Supply voltage test:

Use an appropriate adapter to connect the red meter lead to pin 3 (white/red) of the engine harness connector and the black lead to ground. With *EMM* ON, voltage should be approximately 1 V less than battery voltage.

### Control signal test:

Set meter to the Hz scale to check ignition control signal.

Use an appropriate adapter to connect the red meter lead to pin 2 (orange) of the engine harness connector and the black lead to ground. Activate diagnostics software *Static Ignition* test and observe meter for consistent reading (approximately 2 Hz).

If control signal is present, connect black meter lead to pin 1 (black) and repeat test to confirm harness ground.

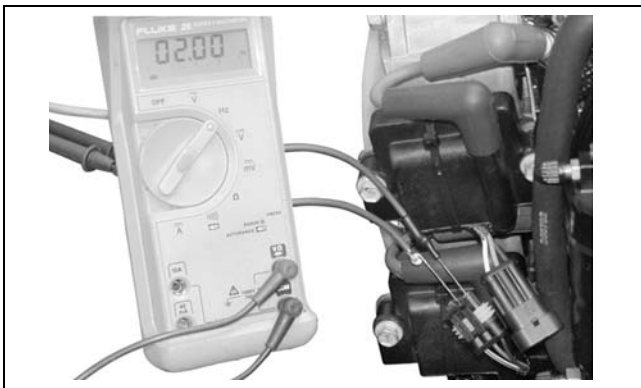

006609

### Harness resistance test:

If control signal is NOT present, calibrate multimeter to low ohms scale. Use appropriate adapters on meter leads to avoid damaging harness connectors.

With *EMM* OFF, remove the *EMM* J1-B connector and test the continuity of each ignition control circuit (orange). Check resistance between J1-B connector and ignition coil connector. Refer to engine wiring diagram.

If circuits test good, replace *EMM*.

## Ignition Coil Tests

There are no simple ignition coil tests available. Before replacing an ignition coil, be sure:

- 55 V is supplied to the white/red wire of the ignition coil connector
- A control signal is present on the orange wire of the ignition coil connector. Refer to **Ignition Control Circuit Tests** on p. 83.
- The black wire of the ignition coil connector provides continuity to ground.
- The secondary spark plug lead provides continuity.

If all of the above tests are good, and a cylinder does not have spark, replace the ignition coil with a known good coil.

## Capacitor Test

**IMPORTANT:** Make sure the capacitor is discharged before testing. Make a momentary connection between the two terminals to ground any stored energy.

Remove capacitor from electrical harness.

Use an ohmmeter set on the high ohms scale to test the capacitor. Connect the meter leads to the capacitor terminals:

- If the capacitor is working correctly, it will store energy from the meter. The resistance reading will increase until it goes to (nearly) infinity.
- If the capacitor is shorted, the reading will immediately show full continuity.
- If there is an open circuit in the capacitor, the meter will show no continuity.

If the resistance reading starts as a negative number, or the reading goes down in value, the capacitor already retains some stored energy. Ground the capacitor and test again.

# FUEL DELIVERY TESTS

## **! WARNING**

**Protect against hazardous fuel spray. Before starting any fuel system service, carefully relieve fuel system pressure.**

Refer to **Relieving Fuel System Pressure** on p. 142.

Check the *Evinrude Diagnostics* software *Stored Faults* screen for current service codes before troubleshooting. Correct any problems and clear the codes FIRST.

Inspect all fuel hoses, filters, and connections. Check quality of fuel supply.

## Fuel Pump Static Test

Use the *Evinrude Diagnostics* software Fuel Pump test to activate the electric fuel pump. If the pump runs, the *EMM* and fuel pump circuit are not at fault.

**IMPORTANT:** Do NOT perform static tests using Diagnostic Power Supply Tool, P/N 587005, with internal 9 volt batteries only. This will produce false results. Refer to **Communication** on p. 63.

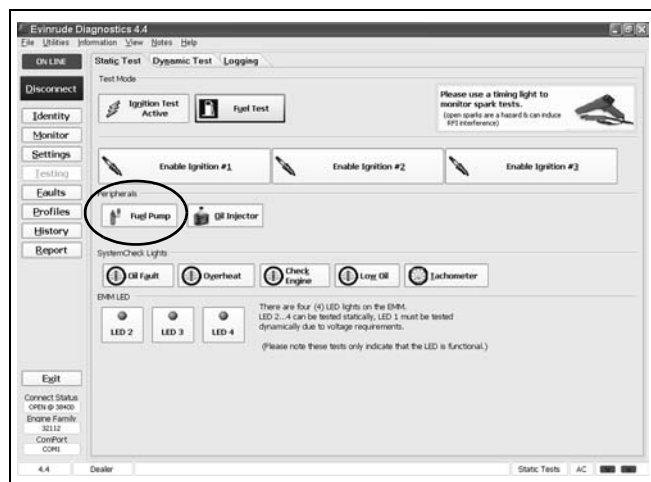

Static Tests Screen

008082

If the pump does not run:

- Check voltage at pin 1 of fuel pump connector. Voltage should be slightly less than 12 V with KEY ON, or when fuel pump test is activated.

Voltage should be 55 V when the outboard is cranking or running.

- The *EMM* controls the fuel pump ground (brown wire). Use an ohmmeter to check continuity between pin 2 of fuel pump connector and ground. Use the fuel pump static test to activate the control function of the *EMM*. Resistance should drop as *EMM* connects the control circuit to ground.
- Refer to **Circulation Pump Resistance Test** on p. 139.

If the pump runs:

- Refer to **Fuel System Pressure Test** on p. 137.
- Refer to **Running Fuel System Tests** on p. 85.

## Fuel Injector Static Test

Use the *Evinrude Diagnostics* software Fuel Injector Static Test to activate each fuel injector. Listen for an audible click from each injector when it is actuated. If the injector activates, the *EMM* and injector circuits are not at fault.

**IMPORTANT:** Do NOT perform static tests using Diagnostic Power Supply Tool, P/N 587005, with internal 9 volt batteries only. This will produce false results. Refer to **Communication** on p. 63.

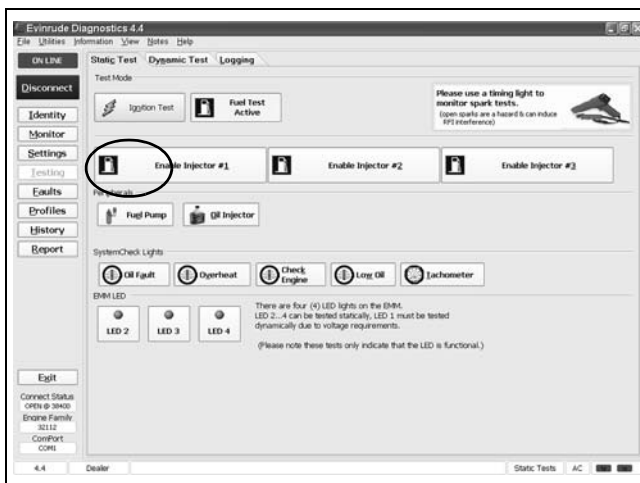

Static Tests Screen

008090

**IMPORTANT:** This test is operating the injectors with 12 V battery power on the system voltage (55 V) circuit. Battery must be fully charged and connections must be clean and tight. Injector activation should be carefully confirmed.



**Results:**

No injectors actuate:

- Use the *Monitor* screen of the diagnostics software to make sure voltage is present on the system voltage circuit.
- Refer to **Running Fuel System Tests** on p. 85.

Some injectors actuate; some do not:

- For non-working injectors, test the resistance of injector circuit between the injector connector and injector control wire at the *EMM*.
- See **Fuel Injector Resistance Test** on p. 139.

All injectors actuate:

- Refer to **Running Fuel System Tests** on p. 85.

## Running Fuel System Tests

Run or crank the outboard.

Use the *Evinrude Diagnostics* software *Monitor* screen to check system voltage. If voltage is low, or drops as RPM increases, refer to **Stator Voltage Output Test** on p. 97.

Use an inductive timing light to monitor the injector control wire (connector pin 2) for each injector. Make sure the pickup is attached to only one wire. Flashes on the timing light indicate current in the circuit is being switched by the *EMM*. The *Dynamic Tests* screen allows the control signal to be turned off to a particular injector.

**IMPORTANT:** Some timing lights may not flash consistently at cranking speeds. Always check the orientation of the timing light pickup and the operation of the timing light.

**Results:**

No light activation on any injector wires (outboard cranks and starter turns flywheel):

- Check stator input to *EMM*, CPS operation, and all grounds and wiring connections.
- Eliminate all other possibilities to isolate a faulty *EMM*.

Irregular or no light activation on some injector wires:

- Test the resistance of individual injector circuits between the injector connector and injector control wire at the *EMM*.
- Check battery cable connections.
- Make sure all grounds are clean and tight.
- See **Fuel Injector Resistance Test** on p. 139.

Steady light activation on all injector wires and consistent voltage readings, *EMM* injector control function is good:

- Use the diagnostics software *Dynamic Fuel Test* to isolate a faulty cylinder. See **DYNAMIC TESTS** on p. 76.



Dynamic Tests Screen

008083

- Refer to **Fuel Injector Pressure Test** on p. 138.
- Refer to **Fuel System Pressure Test** on p. 137.

## SYSTEM ANALYSIS

### EXHAUST WATER VALVE (60–65HP)

# EXHAUST WATER VALVE (60–65HP)

During rapid acceleration, the *EMM* opens a valve that injects water into the exhaust. This water changes exhaust tuning, boosting midrange horsepower as the boat comes on plane.

If the valve is plugged or not working, the operator may not notice a problem during slow acceleration. During rapid acceleration, the outboard will be low on power around 3200 rpm, depending on boat and load.

If the valve is stuck open, the outboard may be low on top speed power (above 4600 RPM).

## Exhaust Water Valve Static Test

Use *Evinrude Diagnostics* software to test the water valve solenoid electrical circuit. The water valve is a 55 volt coil. The static test, which operates on 12 VDC, will not activate the water valve.

Monitor the voltage at pin 2 (blue/red wire) of the the water valve connector. Voltage should drop while the static test is active.

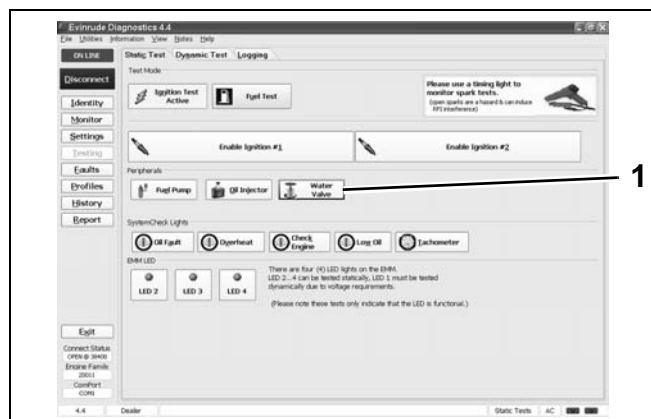

Static Tests Screen

1. Water valve test button

008099

## Exhaust Water Valve Dynamic Test

Use the diagnostics program to perform a dynamic test of the water valve while the outboard is running.

Disconnect the water valve outlet hose.

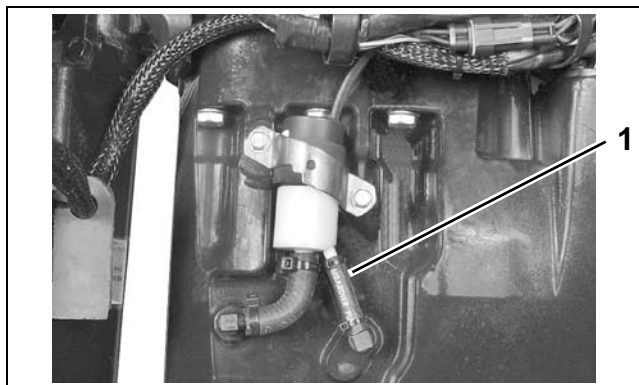

1. Water valve outlet hose

004293

Start the outboard. No water should flow from the hose. If water appears, check for debris in valve assembly.

With the outboard idling, activate the dynamic water valve test and check for water flow. A steady stream of water should flow from the hose while the test is running.

Water should flow at a rate of 18 to 25 ounces / minute (550 to 750cc / minute).

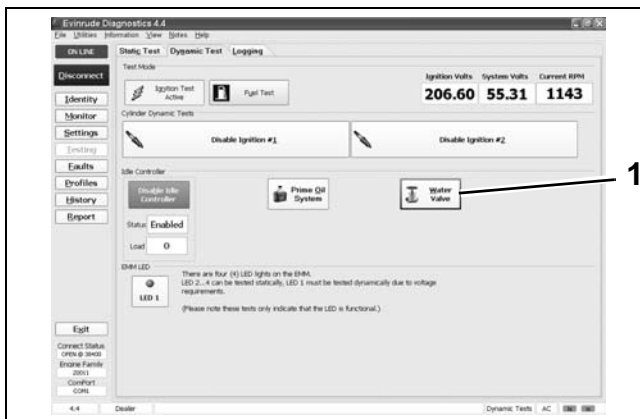

Dynamic Tests Screen

1. Water valve test button

008100

## Results:

- No water flow—check for debris in valve assembly and water supply line. Refer to **EXHAUST WATER VALVE TEST** on p. 106.
- Water appears—make sure fitting into exhaust housing is clear.

# ELECTRICAL AND IGNITION

## TABLE OF CONTENTS

SERVICE CHART .....	88
IGNITION SYSTEM CIRCUIT DIAGRAM, 40 – 65 HP .....	90
IGNITION SYSTEM CIRCUIT DIAGRAM, 75 – 90 HP .....	91
ELECTRICAL HARNESS CONNECTIONS .....	92
GROUND CIRCUITS .....	94
FUSE .....	94
SENSOR TESTS .....	95
CRANKSHAFT POSITION SENSOR (CPS) TEST .....	95
THROTTLE POSITION SENSOR (TPS) TEST .....	95
ENGINE TEMPERATURE SENSOR TEST .....	96
AIR TEMPERATURE SENSOR (AT) TEST .....	96
STATOR TESTS .....	97
STATOR RESISTANCE TESTS .....	97
STATOR VOLTAGE OUTPUT TEST .....	97
CHARGING SYSTEM TESTS .....	98
ELECTRIC START CIRCUIT .....	100
ELECTRIC START TESTS .....	102
REMOTE CONTROL SWITCH TESTS .....	104
TILT/TRIM RELAY TEST .....	106
EXHAUST WATER VALVE TEST .....	106
SYSTEMCHECK CIRCUIT TESTS .....	107
TACHOMETER CIRCUIT TESTS .....	109
FLYWHEEL AND STATOR SERVICING .....	110
FLYWHEEL REMOVAL .....	110
STATOR SERVICE .....	111
FLYWHEEL INSTALLATION .....	111
IGNITION COIL SERVICING .....	112
IGNITION COIL REMOVAL .....	112
IGNITION COIL INSTALLATION .....	112
TIMING ADJUSTMENTS .....	113
TIMING POINTER .....	113
TIMING VERIFICATION .....	114
TPS CALIBRATION .....	114
ELECTRIC STARTER SERVICING .....	115
STARTER REMOVAL .....	115
STARTER INSTALLATION .....	115
CONNECTOR SERVICING .....	116
DEUTSCH CONNECTORS .....	116
AMP CONNECTORS .....	117
PACKARD CONNECTORS .....	119

**SERVICE CHART**

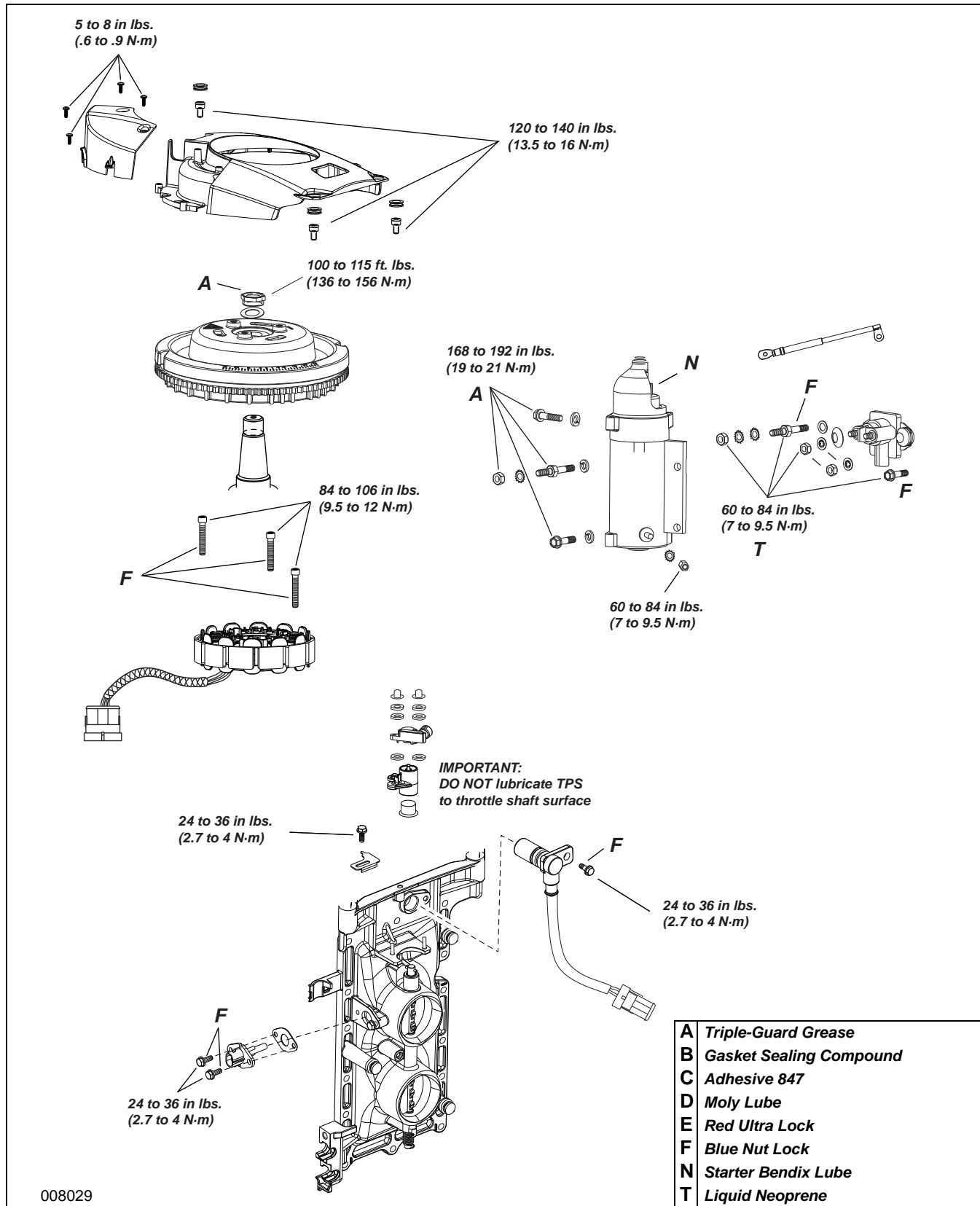

008029

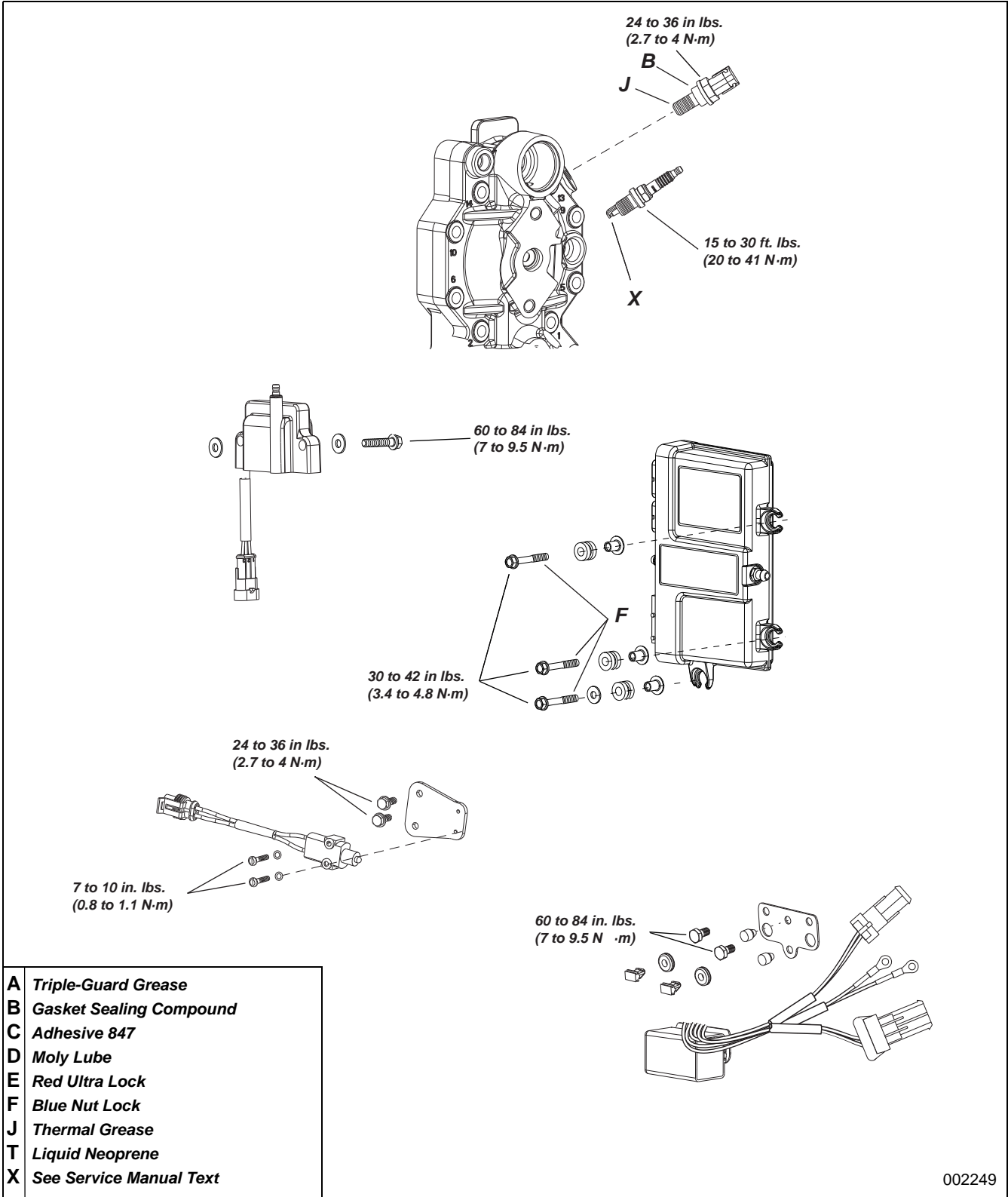

# ELECTRICAL AND IGNITION

IGNITION SYSTEM CIRCUIT DIAGRAM, 40 – 65 HP

## IGNITION SYSTEM CIRCUIT DIAGRAM, 40 – 65 HP

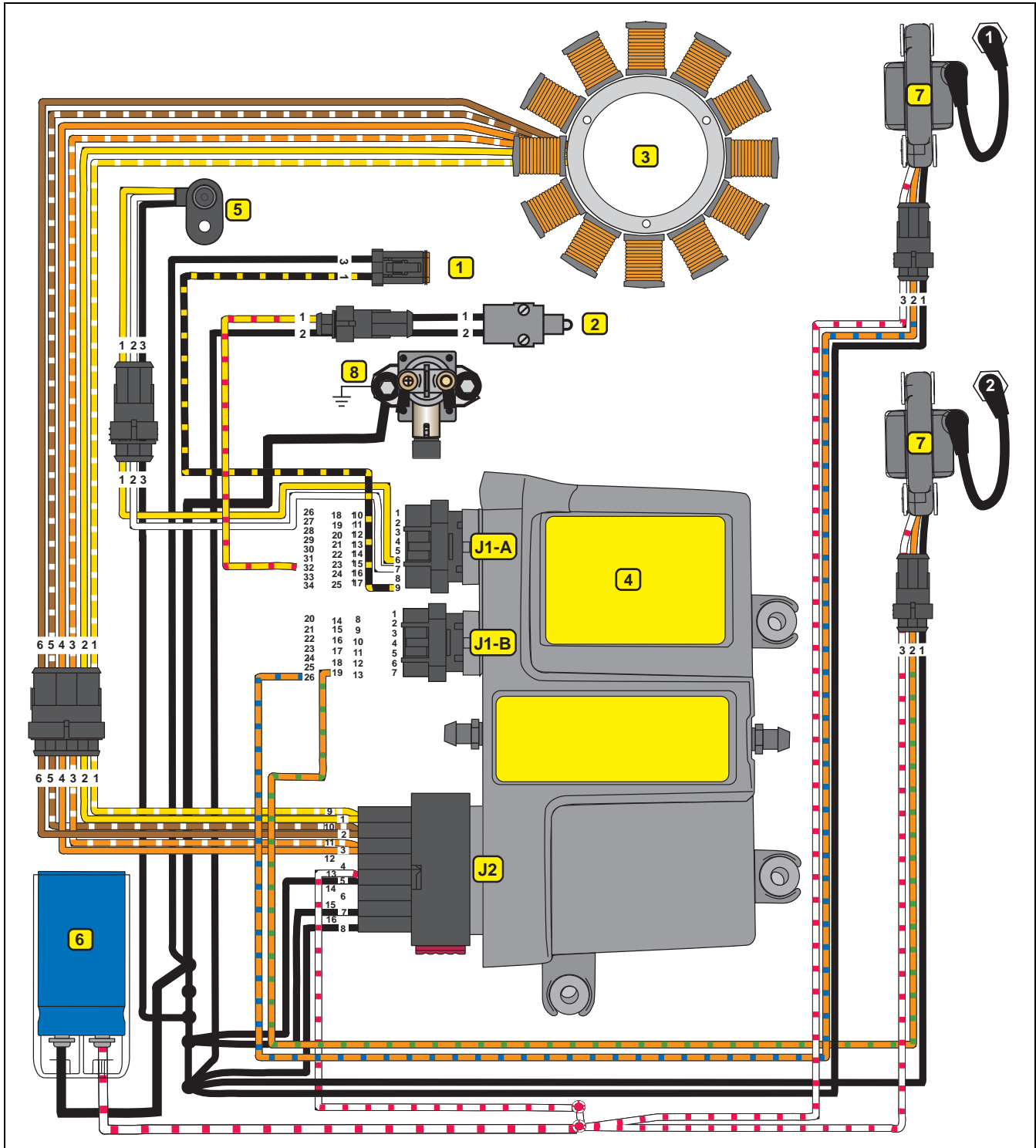

- |                              |                               |                        |
|------------------------------|-------------------------------|------------------------|
| 1. Key switch (stop circuit) | 4. EMM                        | 7. Ignition coil       |
| 2. Neutral switch            | 5. Crankshaft position sensor | 8. Main harness ground |
| 3. Stator                    | 6. Capacitor                  |                        |

# IGNITION SYSTEM CIRCUIT DIAGRAM, 75 – 90 HP

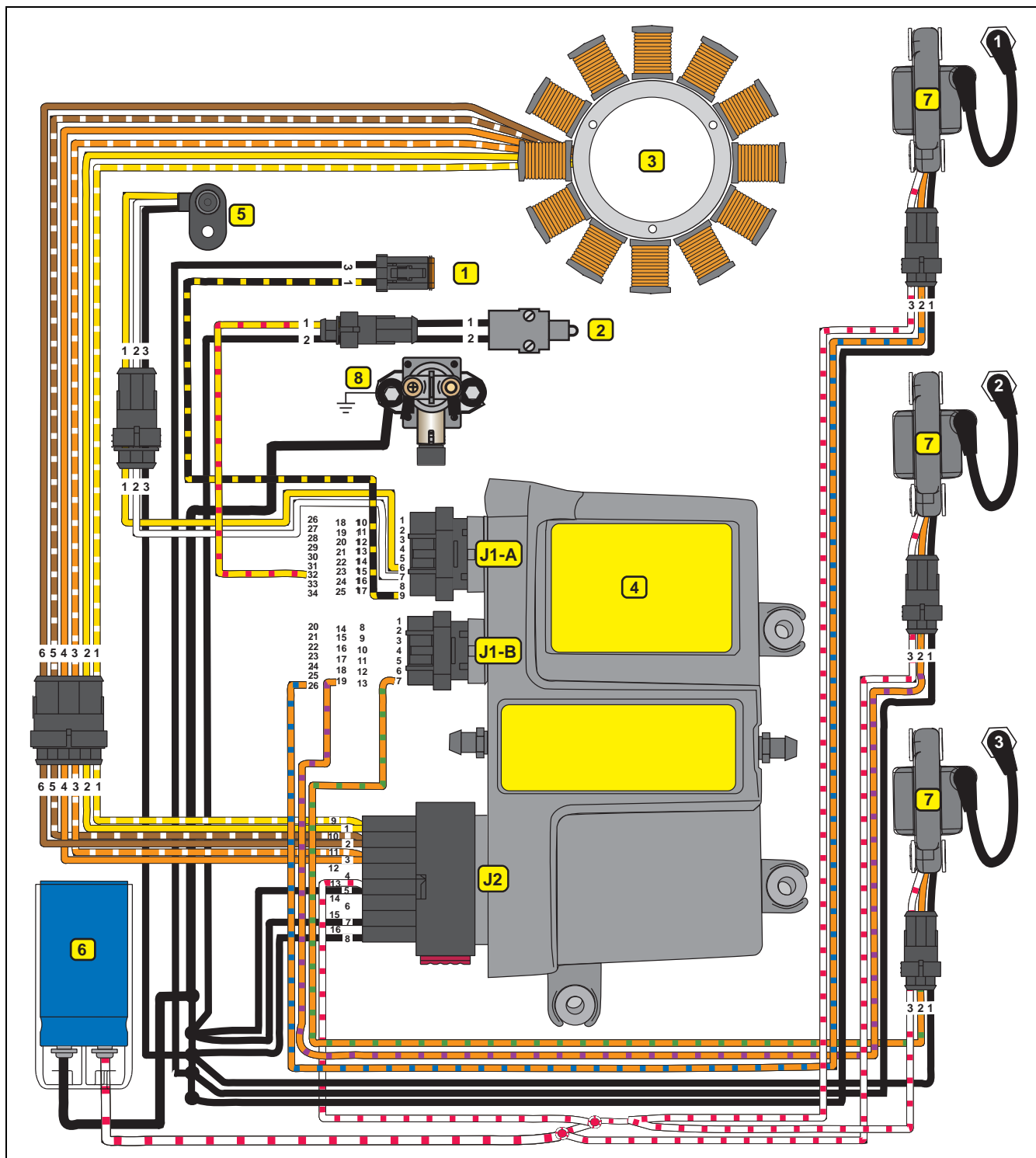

- |                              |                               |                        |
|------------------------------|-------------------------------|------------------------|
| 1. Key switch (stop circuit) | 4. EMM                        | 7. Ignition coil       |
| 2. Neutral switch            | 5. Crankshaft position sensor | 8. Main harness ground |
| 3. Stator                    | 6. Capacitor                  |                        |

6

# ELECTRICAL HARNESS CONNECTIONS

Inspect wiring and electrical connections. Disassemble and clean all corroded connections. Replace damaged wiring, connectors, or terminals. Repair any shorted electrical circuits. Refer to wiring diagrams and reference charts for specific wiring details.

Refer to **CONNECTOR SERVICING** on p. 116.

## Engine Harness to Stator Connector

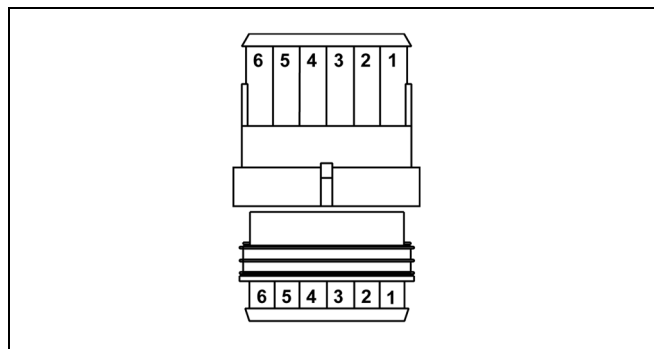

002025

Pin No.	Description of Circuit	Wire Color
1	Stator winding (yellow)	Yellow/White
2	Stator winding (yellow)	Yellow
3	Stator winding (orange)	Orange/White
4	Stator winding (orange)	Orange
5	Stator winding (brown)	Brown/White
6	Stator winding (brown)	Brown

## EMM J1-A Connector

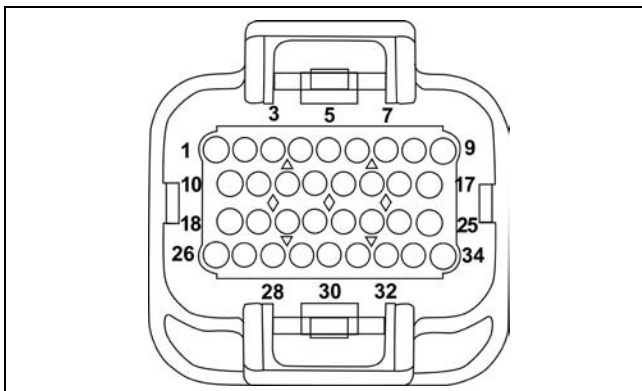

001875

Pin No.	Description of Circuit	Wire Color
1	vacant	
2	Diagnostic connector	Red
3	Diagnostic connector	White
4	vacant	
5	vacant	
6	Crankshaft position sensor (CPS)	Yellow
7	Ground, CPS (digital)	White
8	Bootstrap connector (programming)	Blk/Orange
9	Stop circuit	Blk/Yellow
10	Throttle position sensor (TPS) 5 V	Red
11	vacant	
12	vacant	
13	CANbus, NET-L	Blue
14	CANbus, NET-H	White
15	12 V to EMM (fused)	Red/Purple
16	Tachometer	Gray
17	CHECK ENGINE signal, <i>SystemCheck</i>	Tan/Orange
18	TPS	Green
19	Engine temperature sensor	Pink/Black
20	Air temperature sensor	Pink/Blue
21	CANbus, NET-S	Red
22	CANbus, NET-C	Black
23	vacant	
24	LOW OIL signal, <i>SystemCheck</i>	Tan/Black
25	WATER TEMP signal, <i>SystemCheck</i>	Tan
26	TPS ground (analog)	Black
27	Engine temp. sensor ground (analog)	Black
28	Switched B+ to EMM	Purple
29	LOW OIL switch	Tan/Black
30	vacant	
31	vacant	
32	Neutral switch (shift linkage)	Yellow/Red
33	vacant	
34	vacant	



### EMM J1-B Connector

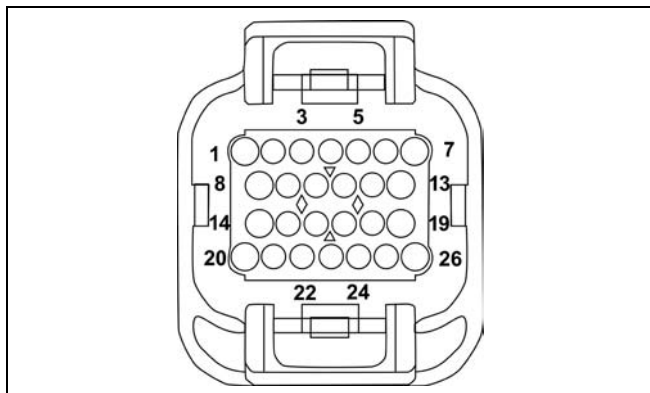

001876

### EMM J2 Connector

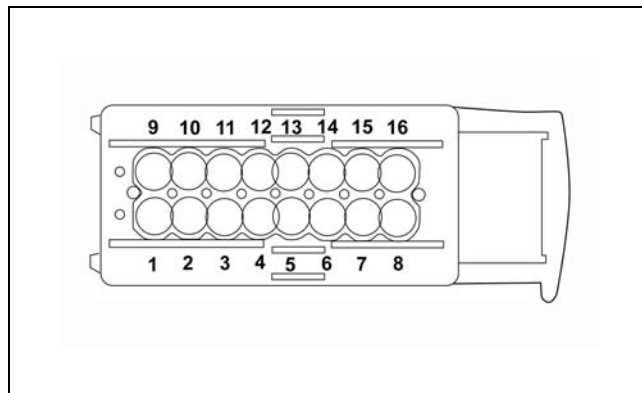

001877

Pin No.	Description of Circuit	Wire Color
1	Injector, cylinder 2, 75–90 HP	Purple
1	Injector, cylinder 2, 40–65 HP	Green
2	Injector, cylinder 3, 75–90 HP	Green
2	Exhaust water valve, 60–65 HP	Blue/Red
3	vacant	
4	vacant	
5	vacant	
6	NO OIL signal, <i>SystemCheck</i>	Tan/Yellow
7	Ignition, cylinder 3, 75–90 HP	Orange/Green
7	vacant, 40–65 HP	
8	Injector, cylinder 1	Blue
9	vacant	
10	vacant	
11	vacant	
12	vacant	
13	vacant	
14	Injector ground	Black
15	vacant	
16	vacant	
17	vacant	
18	vacant	
19	Ignition, cylinder 2, 75–90 HP	Orange/Purple
19	Ignition, cylinder 2, 40–65 HP	Orange/Green
20	Injector ground	Black
21	Injector ground	Black
22	vacant	
23	Oil solenoid	Blue
24	vacant	
25	vacant	
26	Ignition, cylinder 1	Orange/Blue

Pin No.	Description of Circuit	Wire Color
1	Stator winding, 1S	Yellow
2	Stator winding, 2S	Brown
3	Stator winding, 3S	Orange
4	Fuel pump control	Brown
5	System Ground	Black
6	+12 V out	Red
7	System Ground	Black
8	System Ground	Black
9	Stator winding, 1F	Yellow/White
10	Stator winding, 2F	Brown/White
11	Stator winding, 3F	Orange/White
12	Fuel pump (flyback)	White/Red
13	+55 V, out	White/Red
14	+12 V out	Red
15	vacant	
16	vacant	

6

## GROUND CIRCUITS

All ground circuits are essential to reliable out-board performance. Make sure all ground connections are clean and tight. Refer to wiring diagrams for specific wiring details.

### EMM Ground Tests

Disconnect the battery cables at the battery.

Use an ohmmeter to check continuity of ground circuits. Calibrate the ohmmeter on the high ohms scale. Resistance readings for all ground circuits should be 0 W.

- System/power supply grounds: Check continuity between terminal pins 5, 7, and 8 of *EMM* J2 connector and the main harness ground.
- Injector circuit grounds: Check continuity between terminal pins 14, 20, and 21 of the *EMM* J1-B connector and the main harness ground.
- Sensor circuit grounds: Check continuity between terminal pins 26 and 27 of the *EMM* J1-A connector and the appropriate sensor ground connections. Refer to wiring diagrams.

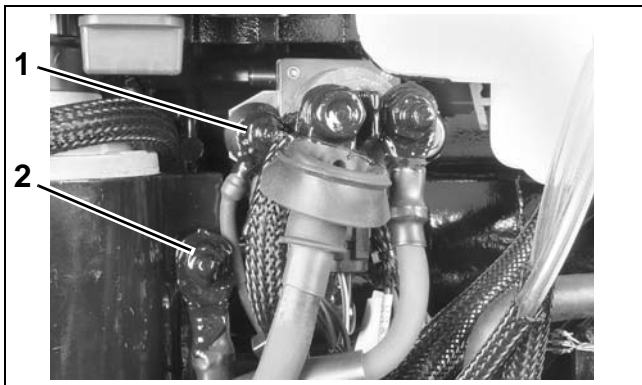

1. Main harness ground  
2. Ground stud (battery) 002292

### Additional Ground Tests

Check connections and continuity at the following locations:

- Starter solenoid terminal B and main harness ground.
- Trim and Tilt module ground at main harness ground.

## FUSE

The engine harness 12 V (B+) circuit is protected by one automotive style 10 amp minifuse.

The fuse is located on the port side of the power-head, in the flywheel cover.

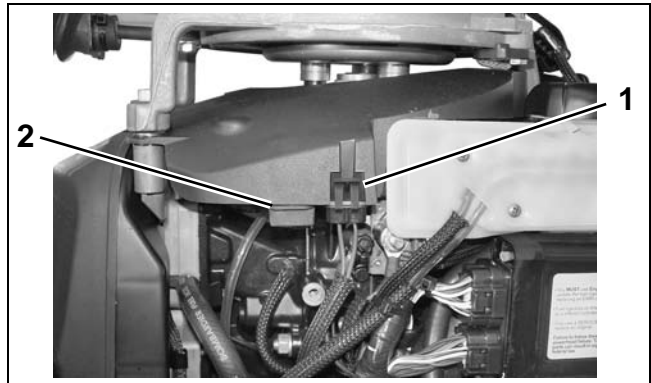

1. Fuse  
2. Spare fuse

005004

**IMPORTANT:** Repeat failures of fuse could be the result of faulty connections or accessories. The 12 V accessory circuit (purple wire from terminal "A" of key switch) is often used to power accessories.

## SENSOR TESTS

All sensor circuits are dependent on wiring and connections, *EMM* supplied current (5 V), and sensor resistance. The supplied current flows through the wiring circuit and sensor before returning to the *EMM*.

**IMPORTANT:** Use *Evinrude Diagnostics* software to monitor sensor circuit voltages or values.

### Crankshaft Position Sensor (CPS) Test

Use the *Evinrude Diagnostics* software CPS Sync and engine RPM displays to confirm a valid CPS signal while the outboard is cranking or running. An RPM display higher than zero indicates a CPS signal to the *EMM*.

Disconnect the crankshaft position sensor.

Use a digital multimeter to measure sensor resistance between the yellow and white wires. The complete circuit can be tested by measuring between pins 6 and 7 of the *EMM* J1-A connector.

Sensor Resistance
560 $\Omega$ $\pm$ 10% @ 77°F (25°C)

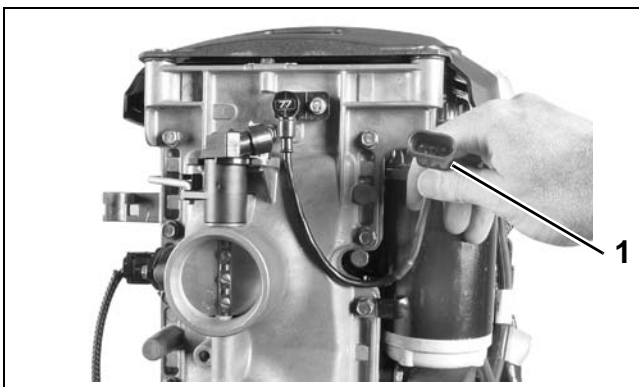

1. CPS Connector

002286

The CPS is mounted to the throttle body housing and requires no adjustment. Air gap or clearance to flywheel is fixed at approximately 0.073 in.

(1.85 mm). The acceptable clearance is 0.036 to 0.110 in. (1 to 2.8 mm).

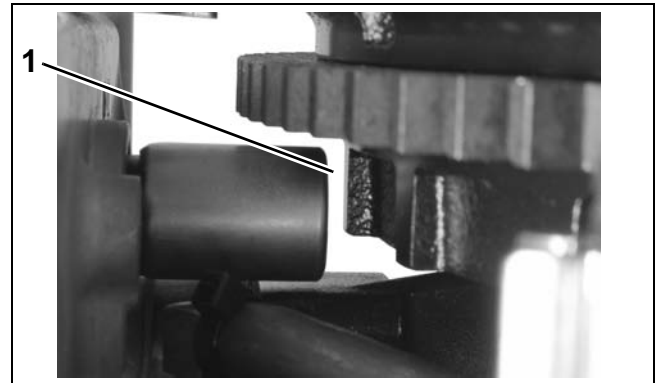

1. CPS gap

006527

### Throttle Position Sensor (TPS) Test

Use *Evinrude Diagnostics* software to monitor TPS voltage while the outboard is running. Voltage should change evenly as sensor lever is moved.

Remove the electrical connector from the throttle position sensor.

Use a digital multimeter to measure sensor resistance.

Sensor Resistance between "A" and "B"
3000 to 7000 $\Omega$ @ 77°F (25°C)

Sensor Resistance between "A" and "C"
4000 to 8000 $\Omega$ @ 77°F (25°C)

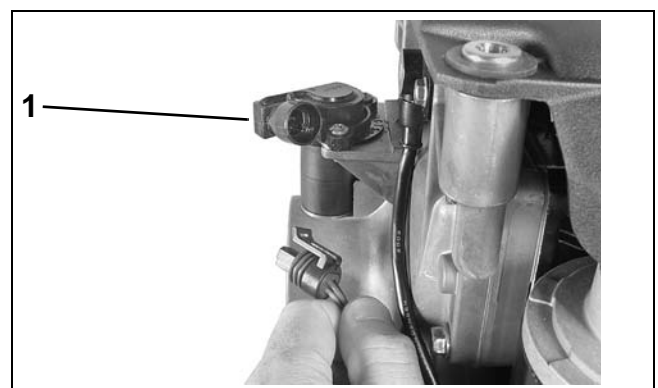

1. TPS

002289

## ELECTRICAL AND IGNITION SENSOR TESTS

Connect red meter lead to terminal “A” and black meter lead to terminal “C.” Rotate the sensor lever through its range of travel. Resistance reading must change evenly as the sensor lever is moved.

Connect red meter lead on terminal “B” and black meter lead to terminal “C.” Rotate the sensor lever. Resistance reading must change evenly as the sensor lever is moved.

### Engine Temperature Sensor Test

Remove the electrical connector from the engine temperature sensor.

Use a digital multimeter to measure sensor resistance.

Engine Temperature Sensor Resistance
680 $\Omega$ $\pm$ 5% @ 212°F (100°C)
10000 $\Omega$ $\pm$ 1% @ 77°F (25°C)
32654 $\Omega$ $\pm$ 2.5% @ 32°F (0°C)

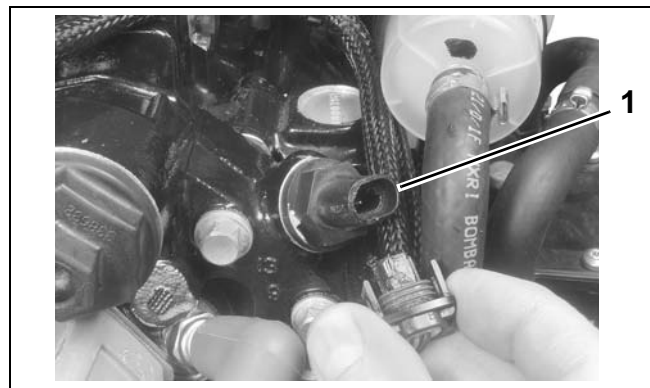

1. Engine temperature sensor

006612

### Air Temperature Sensor (AT) Test

Remove the electrical connector from the air temperature sensor.

Use a digital multimeter to measure sensor resistance.

AT Sensor Resistance
680 $\Omega$ $\pm$ 5.25% @ 212°F (100°C)
10000 $\Omega$ $\pm$ 1.5% @ 77°F (25°C)
32654 $\Omega$ $\pm$ 3.0% @ 32°F (0°C)

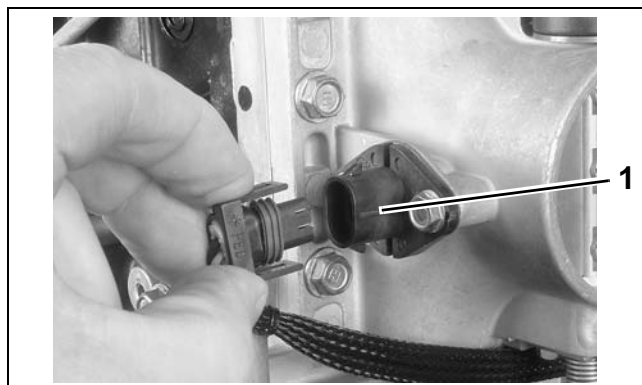

1. AT sensor

006613

## STATOR TESTS

The stator consists of 3 windings (4 poles each) on a 5 inch diameter core and generates an output voltage of 55 VAC (1100 watts maximum). This voltage is converted by the *EMM* to provide 12 VDC for battery charging (3 to 5 A at 500 RPM and 25 A from 3000 RPM to WOT) and 55 VDC for fuel injector, and fuel and oil pump operation.

### Stator Resistance Tests

Use a digital multimeter to check resistance of stator windings.

Disconnect *EMM* J2 connector from *EMM*.

Stator Winding Resistance Specification
Yellow & Yellow / white .670 ± 0.020 Ω @ 73°F (23°C)
Brown & Brown / white .670 ± 0.020 Ω @ 73°F (23°C)
Orange & Orange / white .670 ± 0.020 Ω @ 73°F (23°C)

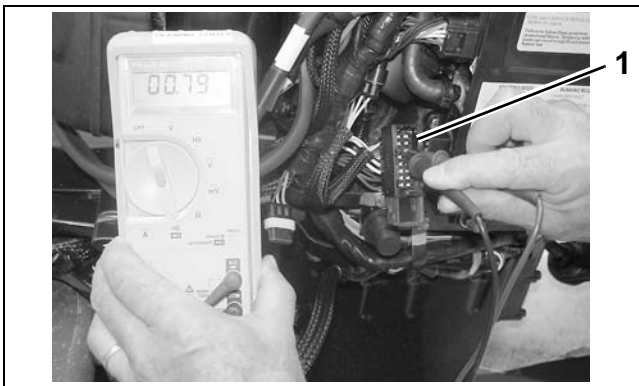

1. EMM J2 Connector

002462

Connect meter leads to the following pins:

- Yellow/white and yellow (pins 9 and 1)
- Brown/white and brown (pins 10 and 2)
- Orange/white and orange (pins 11 and 3)

**IMPORTANT:** A reading of less than 2 ohms is acceptable. Make sure meter is calibrated to read 1 ohm or less.

To check for a grounded winding, connect one meter lead to ground and alternately connect the other meter lead to each stator wire. Meter should read no continuity. If meter reads continuity, replace stator.

### Stator Voltage Output Test

#### *ELECTRIC START MODELS*

Use a digital multimeter to check stator output voltage. Set meter to read 110 VAC output.

#### **⚠ WARNING**

**To prevent accidental starting of outboard, disconnect crankshaft position sensor (CPS).**

Disconnect CPS.

Disconnect stator (6-pin) connector from the engine harness (6-pin) connector.

Connect Stator Test Adaptor tool, P/N 5005799, to stator connector.

Connect meter leads to terminals of adaptor tool.

With a fully charged battery, crank outboard (300 RPM minimum) and observe meter reading:

- 30 VAC at 300 RPM
- 40 VAC at 400 RPM
- 55 VAC above 500 RPM



1. Stator Test Adaptor

002396

## ELECTRICAL AND IGNITION

### CHARGING SYSTEM TESTS

#### ROPE START MODELS

Use a Peak Reading Voltmeter, P/N 507972, to check stator output voltage. Set meter to the 50 VAC scale.

#### WARNING

To prevent accidental starting of outboard, disconnect crankshaft position sensor (CPS).

Disconnect CPS. Remove spark plugs. Make sure outboard is in NEUTRAL. Refer to **SPARK PLUGS** on p. 42.

Disconnect stator (6-pin) connector from the engine harness (6-pin) connector.

Connect Stator Test Adaptor tool, P/N 5005799, to stator connector.

Connect meter leads to terminals of adaptor tool.

Rotate the flywheel with the starter rope, using a long, steady pull.

Stator output voltage should be approximately 30 VAC.

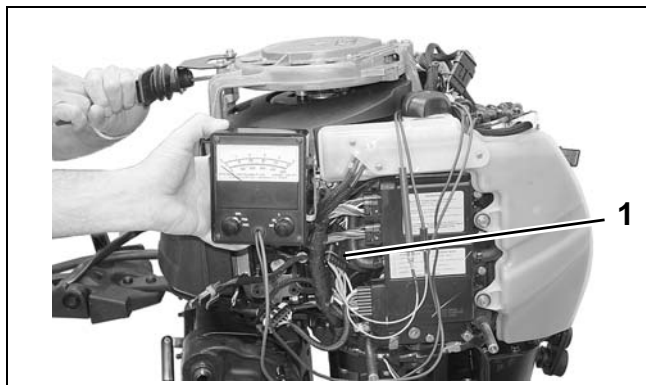

1. Stator Test Adaptor

006750

**IMPORTANT:** Index all spark plugs. Refer to Spark Plug **Indexing** on p. 42.

## CHARGING SYSTEM TESTS

### 12 V Charging Circuit

To test the operation of the regulator in the *EMM*, you must be able to run the outboard continuously at approximately 5000 RPM, such as in a test tank or on a marine dynamometer.

The test consists of monitoring the system's response to a partially discharged battery. Use a variable load tester to discharge the battery.

**IMPORTANT:** The regulator requires voltage to operate. Before proceeding, make sure there is at least 7 V on the positive terminal of the starter solenoid.

Disconnect the battery cables at the battery.

Use an inductive amp meter or connect a 0 to 50 A ammeter in series between the red wire of engine wire harness (alternator output from *EMM*) and the positive (B+) battery cable terminal of starter solenoid.

*Fluke*<sup>†</sup> model 334 or 336, *Snap-On*<sup>†</sup> model MT110 or EETA501, and various other amp meters should be available through local tool suppliers.

Reconnect the battery cables.

Following the manufacturer's directions, connect the variable load tester (carbon pile) across the battery terminals. *Stevens* model LB-85 and *Snap-On* model MT540D are examples of testers available.

**⚠ WARNING**

**Excessive battery discharge rates might overheat battery causing electrolyte gassing. This might create an explosive atmosphere. Always work in a well ventilated area.**

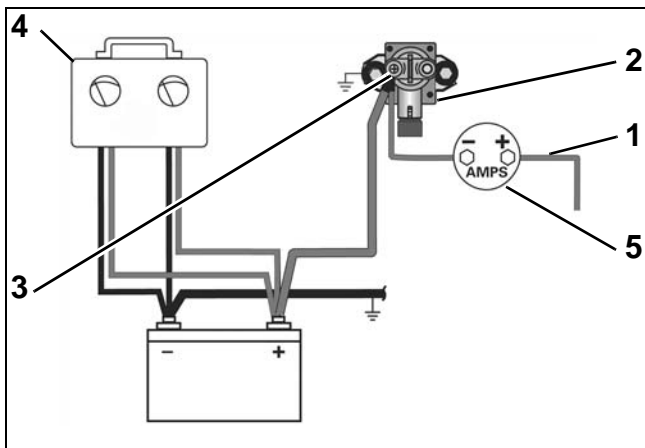

**Variable Load Test Diagram**

002077

1. Red wire (alternator output from EMM)
2. Starter solenoid
3. Battery cable terminal (B+)
4. Variable load tester
5. Ammeter

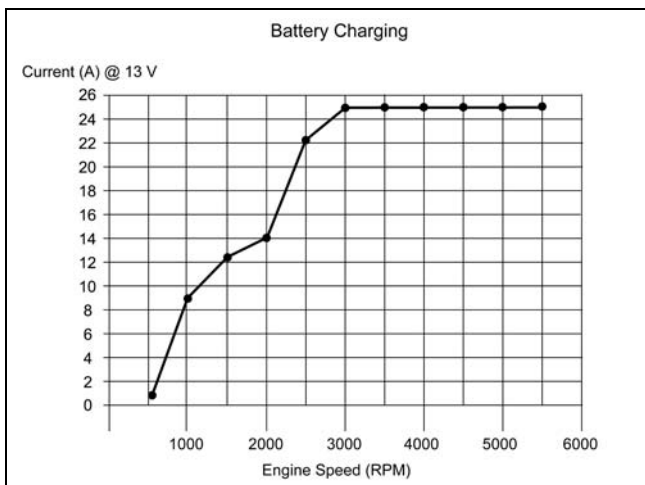

**Battery Charging Graph**

002076

Start and run the outboard at approximately 5000 RPM. Use the variable load tester to draw the battery down at a rate equivalent to the stator's full output.

- The ammeter should indicate nearly full output, approximately 25 A @ 5000 RPM.

Decrease the battery load toward 0 A.

- Ammeter should show a reduced output. As the current draw decreases, the battery voltage should stabilize at approximately 14.5 V.
- If results vary, check stator BEFORE replacing the *EMM*. Refer to **STATOR TESTS** on p. 97.

**55 V Alternator Circuit**

Check battery ground cable for continuity.

With the key switch ON, check battery voltage at battery (12 V).

Then, use Electrical Test Probe Kit, P/N 342677, and a digital multimeter set to read 55 VDC to check voltage on white/red wires at J2 connector of *EMM*. Voltage at *EMM* connector should be 0.5 to 1 V less than battery.

**6**

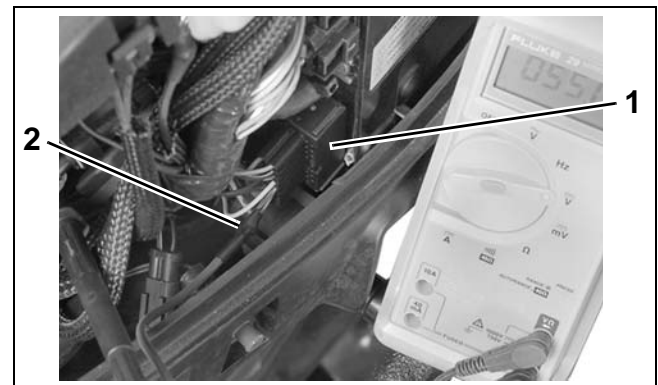

1. J2 connector
2. Test probe

007261

With outboard running at 1000 RPM, voltage on white/red wires should be 55 V. Voltage readings at a specific speed (RPM) should be steady.

If there is any other reading, refer to **STATOR TESTS** on p. 97. Inspect the stator wiring and connections. Inspect the capacitor wiring, connections, and capacitor. Repair the wiring or replace a faulty capacitor, stator, or *EMM*.

# ELECTRIC START CIRCUIT

## Start Circuit Diagram

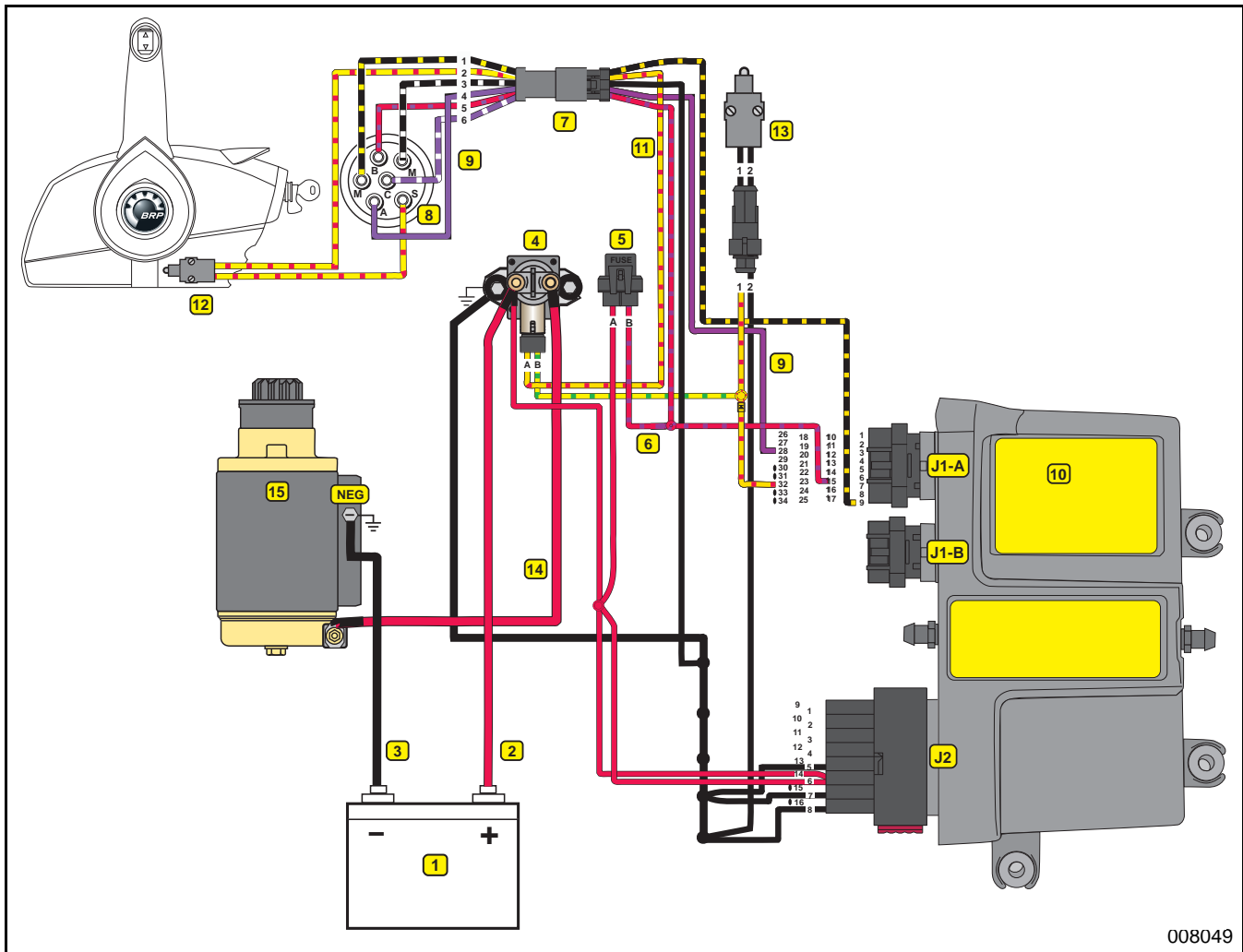

008049

- 1. Marine battery
- 2. RED wire (POS)
- 3. BLACK wire (NEG)
- 4. Starter solenoid
- 5. Fuse (10 amp)
- 6. RED/PURPLE wire
- 7. Key switch connectors
- 8. Ignition switch
- 9. PURPLE wire (switched B+)
- 10. Engine Management Module (EMM)
- 11. YELLOW/RED wire, start
- 12. Neutral Safety Switch (remote control)
- 13. Neutral Safety Switch (engine)
- 14. RED starter motor cable
- 15. Electric starter motor



## Start Circuit Operation

The starter must engage and turn the flywheel. The outboard must crank a minimum of 300 RPM to start.

Starter performance depends on the following:

- Proper battery and cable capacity.
- Clean, tight cable connections.
- Solenoid activation through the key switch and neutral safety switch.

Refer to **Predelivery and Installation Guide** for battery, terminal, and cable requirements.

## Solenoid Wiring

The positive (B+) battery cable connects to a large terminal of the starter solenoid. This terminal also provides the 12 V power supply to the engine harness (red wire) and the 10 A fuse. The red/purple wire from the fuse holder (10 A) provides 12 V to terminal “B” of key switch.

The negative (B-) battery cable connects to the main ground stud on the starter housing.

## Engine Wire Harness

Contains the following circuits:

- Red/purple output wire from fuse provides 12 V to instrument harness.
- Purple wire provides switched 12 V to *EMM*.
- Yellow/red wire provides switched 12 V to solenoid (terminal “A”).
- Yellow/green wire provides ground (NEG) to starter solenoid (terminal “B”).

## Instrument Wire Harness

Contains the following circuits:

- Red/purple wire provides 12 V to key switch terminal “B”.
- Purple wire provides switched 12 V to engine wire harness.
- Yellow/red wire from terminal “S” of key switch provides switched 12 V to solenoid (terminal “A”) (key switch in START position).

## Key Switch, ON position

12 V is applied to the accessory circuit. Key switch ON:

- Switches 12 V to terminal “A” of key switch and to the purple wires of the wire harnesses.
- Provides 12 V input to terminal 28 of *EMM* J1-B connector. *EMM* turns ON.

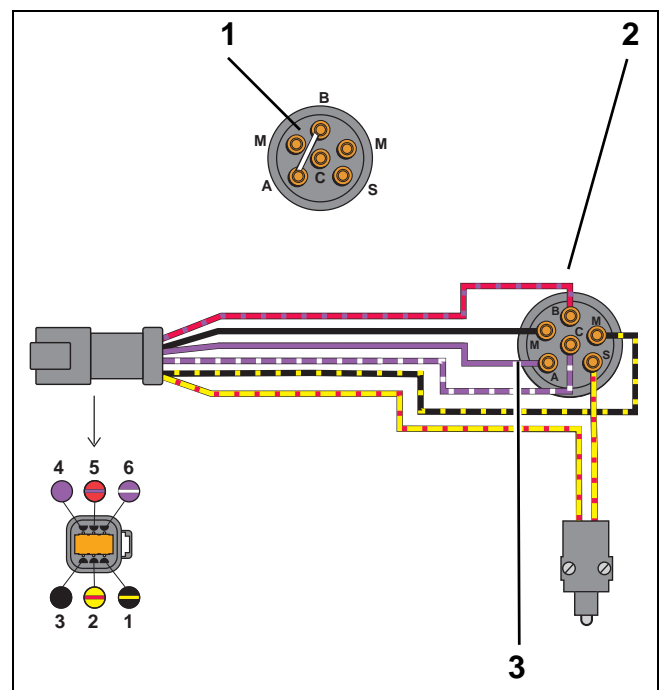

1. Key switch, ON position – Continuity between terminals “B” and “A”
2. Terminal “B”, 12 V (Red/purple)
3. Terminal “A”, 12 V (Purple)

000691

## ELECTRICAL AND IGNITION

### ELECTRIC START TESTS

#### Key Switch, START Position

Key switch START:

- Switches 12 V to terminal “S” of key switch and to the neutral safety switch (in remote control).
- A closed neutral safety switch provides 12 V to the engine wire harness yellow/red wire and solenoid (terminal “A”).

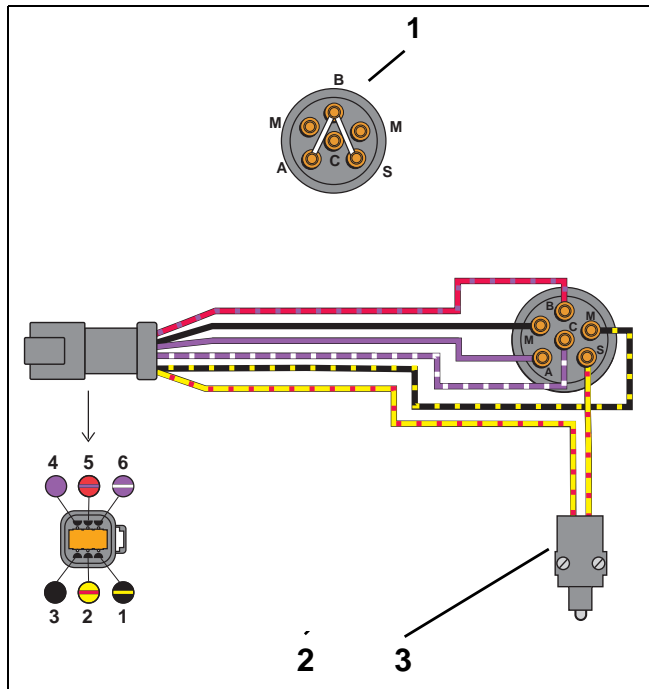

1. Ignition switch, START position – Continuity between terminals “B” and “A”; “B” and “S”
2. Terminal “S”, 12 V
3. Neutral safety switch

000691R

## ELECTRIC START TESTS

### Starter Solenoid Test

Disconnect the B+ (POS) battery cable at the battery.

**IMPORTANT:** Disconnect all wiring from solenoid terminals before proceeding with this test.

Use a digital multimeter to measure resistance.

Put one meter lead on the starter positive (+) cable terminal and the other lead on the battery positive (+) cable terminal:

- Meter must not show continuity (high reading).
- If meter shows continuity (low reading), replace the solenoid.

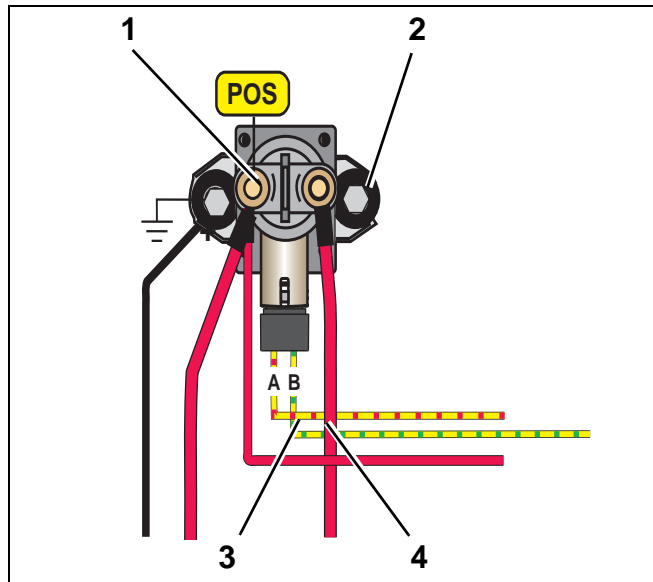

1. Battery positive cable (B+) terminal
2. Starter positive (+) cable terminal
3. “A” terminal (yellow/red)
4. “B” terminal (yellow/green)

002073

Apply B+ to terminal “A” of solenoid and ground (NEG) to terminal “B” of solenoid. Measure resistance between the starter positive (+) cable terminal and the positive battery (+) cable terminal.

- The solenoid must close with an audible click.
- Meter must show continuity (low reading).
- If meter shows no continuity (high reading), replace the solenoid.

After re-installing the solenoid, coat all wires and terminals with *Black Neoprene Dip*.

## Starter Voltage Drop Test

### ⚠ WARNING

To prevent accidental starting of outboard, disconnect crankshaft position sensor (CPS).

Use a digital voltmeter to measure the voltage drop on each section of the start circuit.

If any voltage reading is greater than 0.5 VDC check that connections are clean, tight and free of corrosion. Clean or replace any corroded or damaged cables or connections.

**STEP 1:** Connect voltmeter positive (+) lead to the terminal for the negative (-) battery cable at powerhead. Connect voltmeter negative (-) lead to negative (-) battery post.

- Activate starter motor and observe voltage reading.

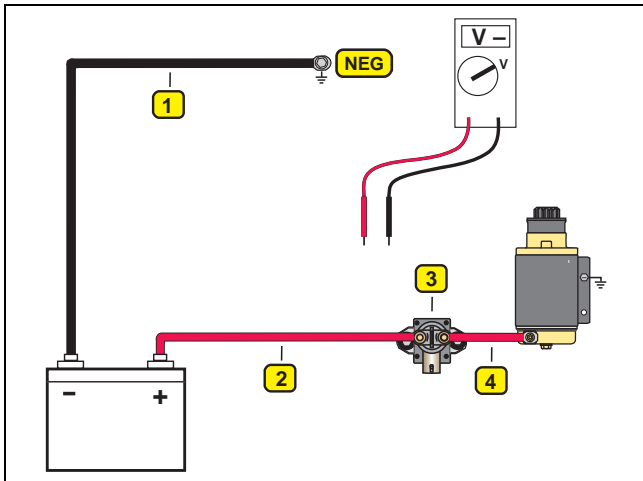

1. Negative battery cable
2. Positive battery cable
3. Solenoid
4. Starter cable

008464

**STEP 2:** Connect positive (+) lead to battery positive (+) terminal. Connect negative (-) lead to starter solenoid terminal.

- Activate starter motor and observe voltage reading.

**STEP 3:** First, activate starter motor. Connect positive (+) lead to starter solenoid terminal. Connect negative (-) lead to opposite starter solenoid terminal.

- Observe voltage reading.

**STEP 4:** Connect positive (+) lead to starter cable of solenoid terminal. Connect negative (-) lead to starter motor terminal.

- Activate starter motor and observe voltage reading.

## No Load Current Draw Test

Securely fasten starter in a vise or suitable fixture before proceeding with this check.

Use a battery rated at 500 CCA (60 amp-hr) or higher that is in good condition and fully charged.

Use an inductive ammeter or connect a 0 to 100 amp ammeter in series with a heavy jumper between the battery positive (+) terminal and the starter positive (+) terminal.

Fluke model 334 or 336, Snap-On model MT110 or EETA501, and various other ammeters should be available through local tool suppliers.

Attach or hold a vibration tachometer, such as a *Frahm*<sup>†</sup> *Reed* tachometer, to the starter.

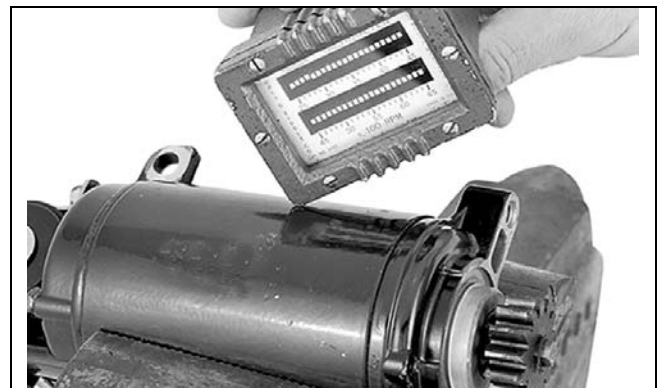

24083

Complete the circuit with a heavy jumper between the battery negative (-) terminal and the starter frame.

Monitor the starter RPM and current draw.

- At 10,500 RPM the ammeter should show a maximum of 30 A.

# REMOTE CONTROL SWITCH TESTS

## Key Switch Test

Refer to **Wiring Diagrams** at back of manual.

Use an ohmmeter or a continuity light to test key switch operation. Replace switch if results are incorrect with any of the following tests.

**IMPORTANT:** Disconnect battery and key switch wiring before proceeding with the following tests.

**Stop/Ground Terminals (M)** – Connect meter between the two “M” terminals. Meter must indicate NO continuity at START or ON.

Turn key switch OFF. Meter must indicate continuity.

**Accessory Terminal (A)** – Make sure the key switch is OFF. Connect the ohmmeter or continuity light between terminals “B” (battery) and “A” (accessory) of key switch. Meter must indicate NO continuity.

Turn switch ON. Meter must indicate continuity.

Turn key switch to START. Meter must continue to indicate continuity.

**Starter Terminal (S)** – Hold key switch at START. Connect meter between terminal “B” and terminal “S.” Meter should indicate continuity.

**IMPORTANT:** The choke function or terminal “C” of the key switch is NOT used.

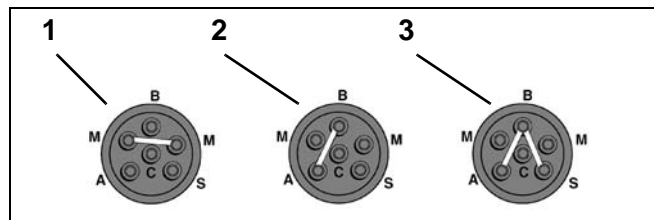

1. OFF  
 2. ON  
 3. START  
 000443R

## Neutral Start Circuit Test

Use an ohmmeter or continuity light to test the continuity of the circuit while positioning the remote control in NEUTRAL, FORWARD, and REVERSE.

**IMPORTANT:** Turn propeller shaft or disconnect shift cable to allow proper remote control shift action while outboard is not running. Disconnect the instrument harness connector from the key switch harness connector.

Make sure the remote control handle is in NEUTRAL. Connect meter between terminal 5 (red/purple wire) and terminal 2 (yellow/red wire). Turn the key switch to START. Meter must indicate continuity.

Move the remote control handle to FORWARD and turn the key switch to START. Meter must NOT indicate continuity.

Move the remote control handle to REVERSE and turn the key switch to START. Meter must NOT indicate continuity.

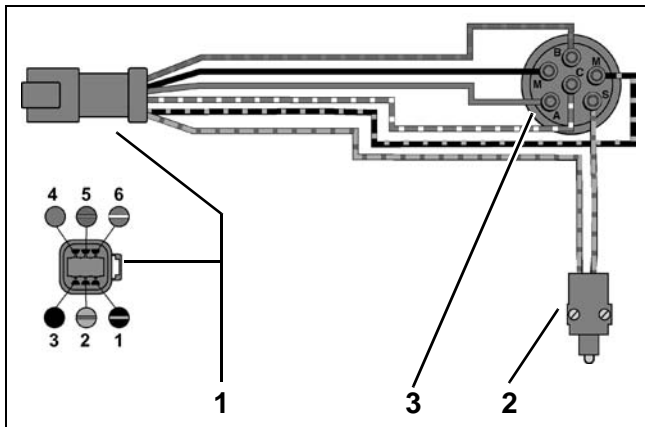

1. Key switch harness connector  
 2. Neutral start switch  
 3. Key switch

000443

**IMPORTANT:** Reconnect shift cable and instrument harness connector to key switch harness connector.

## Neutral Start Switch Test

Use an ohmmeter or a continuity light to test neutral start switch operation.

**IMPORTANT:** All wiring must be disconnected from the switch before proceeding with this test.

Disassemble the remote control and remove the neutral start switch.

Connect one meter lead to each terminal of the switch.

- Meter must indicate continuity when the plunger is depressed
- Meter must indicate no continuity when the plunger is released.

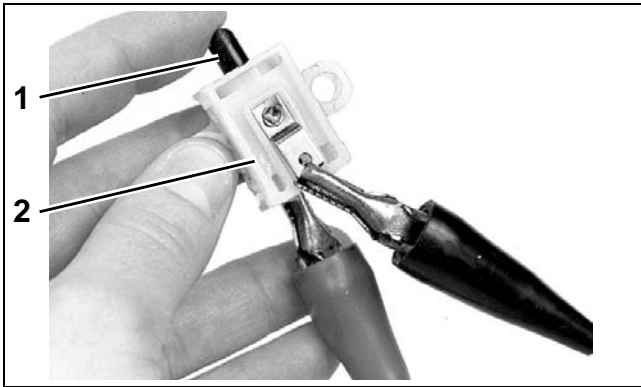

**TYPICAL**  
1. Plunger  
2. Neutral start switch

3224

Replace switch if results are incorrect.

## Emergency Stop Switch Test

This switch can be part of the key switch or installed as a separate switch. Either style connects the “M” terminals of the key switch.

The emergency stop switch function grounds the stop circuit wire (black/yellow) when the lanyard clip is removed. One “M” terminal is the ground wire (black) and one “M” terminal is the stop circuit wire (black/yellow).

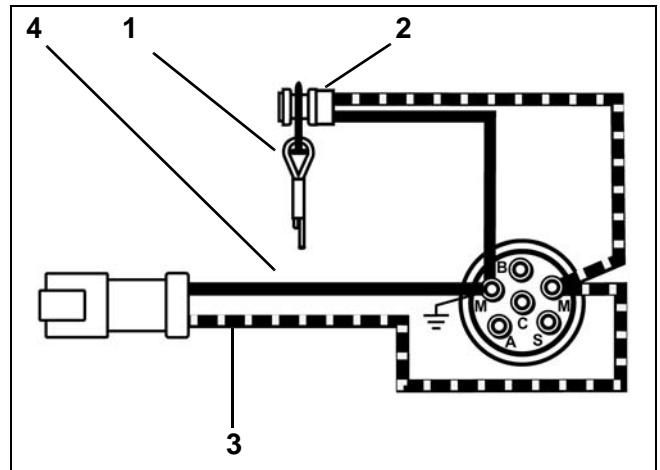

1. Lanyard and clip assembly
2. Emergency stop switch, separate from key switch
3. Stop circuit wire (black/yellow)
4. Ground wire (black)

000444

Install the clip on the emergency stop switch or key switch. Start the outboard. Pull the clip from the switch. The outboard must stop running.

## TILT/TRIM RELAY TEST

The tilt and trim (TNT) module contains the circuitry and relays required for power trim and tilt operation.



1. Tilt and trim module

006754

The tilt and trim switch provides B+ input to green/white or blue/white wire of the TNT module.

### Operation

The relay activates when B+ input from the switch is supplied to terminal 86 of the internal relays.

Terminal 87a connects to ground (B-).

Terminal 87 connects to B+.

Terminal 30 connects TNT motor.

Terminals 87a and 30 are connected when relay is not activated. This supplies ground (B-) connection to TNT motor.

Terminals 87 and 30 are normally open. B+ is applied to terminal 30 when relay is activated. This supplies ground B+ connection to TNT motor.

Refer to **Tilt and Trim Module Diagram**.

### Test Procedure

Make sure red and black wires are connected to 12 V battery power supply.

Set voltmeter to 12 VDC scale. Connect test leads to terminals "A" and "B" of TNT motor connector.

Use a wire jumper to alternately connect B+ to terminals "1" and "2" of tilt and trim switch connector.

The meter must indicate battery voltage (12 V) with B+ connected to either terminal.

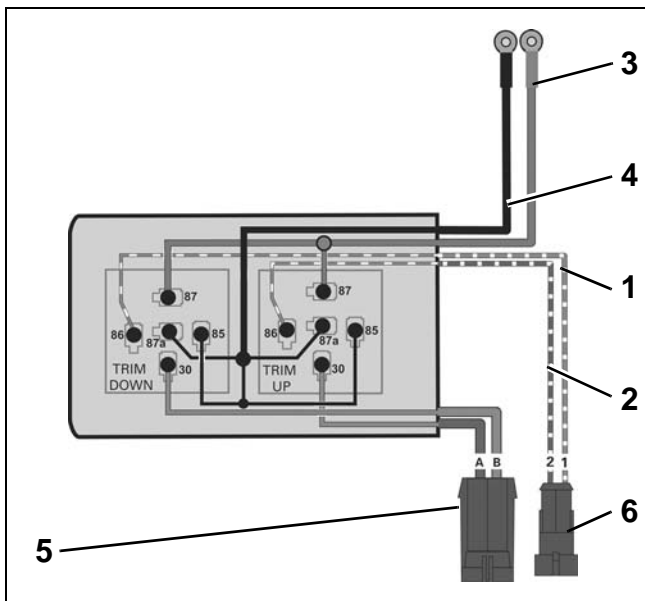

**Tilt and Trim Module Diagram**

002063

1. Green/white wire
2. Blue/white wire
3. B+, red wire
4. B-, black wire
5. TNT motor connector
6. TNT switch connector

## EXHAUST WATER VALVE TEST

Disconnect electrical connector from water valve solenoid. Use an ohmmeter to measure solenoid resistance.

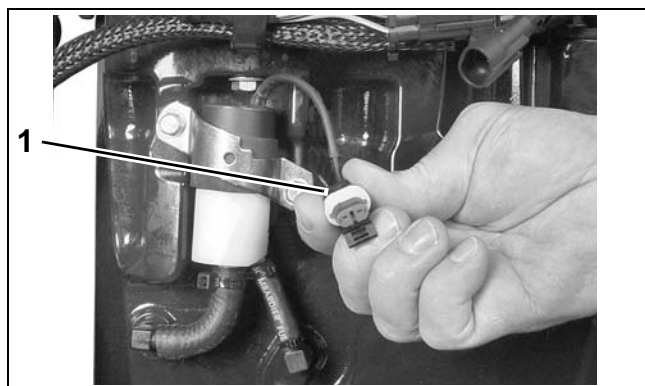

1. Water valve electrical connector

004297

### Water Valve Solenoid Resistance

295  $\Omega$   $\pm$  20 @ 77°F (25°C)

## SystemCheck CIRCUIT TESTS

Make sure the *SystemCheck* engine monitor can warn the operator during a “NO OIL,” “WATER TEMP” or “HOT,” “CHECK ENGINE,” or “LOW OIL” condition. Check the condition of the warning system and associated wiring and connections. Test the engine monitor regularly and anytime you suspect an alert situation has been missed.

The instrument harness must be connected to the outboard before performing the following tests. Refer to the **Engine Wiring** diagram and the **MWS Instrument Wiring** diagram in the back of this manual.

**IMPORTANT:** Use jumper wires made with the appropriate terminals to test the warning circuits.



42811

### Gauge Self-Test Check

Turn the key switch to ON with the outboard NOT running. The gauge warning lights for NO OIL, WATER TEMP, CHECK ENGINE, and LOW OIL must all light at once, then turn off in sequence, and the warning horn must sound for one-half second.

If the gauge lights do not turn on, turn the key switch OFF. Disconnect the gauge 8-pin connector from the back of the gauge and turn the key switch ON. Test for battery voltage between

instrument harness terminal 1 (purple wire) and terminal 2 (black wire).

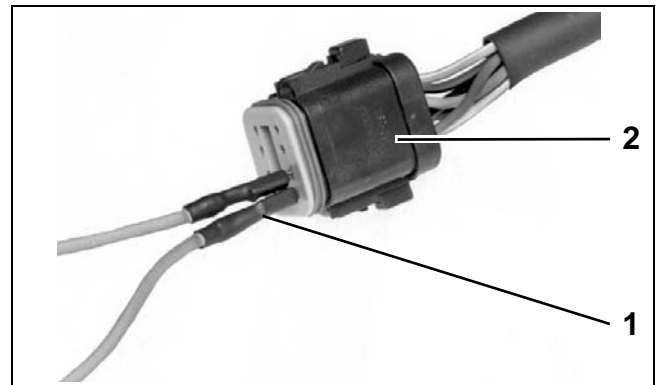

1. Test adapter(s)  
2. Connector, SystemCheck gauge

42761

- If battery voltage is present, replace the gauge.
- If there is no battery voltage, check that 12 V is present at terminal “B” of the key switch. Check condition of the instrument harness, key switch, and connections.

If the lights worked, but the warning horn did not sound for one-half second, turn the key switch OFF. Disconnect the warning horn 2-pin connector. Substitute a known good warning horn. Turn the key switch ON.

- If the substitute horn beeps, the original horn is defective and must be replaced.
- If the substitute horn does not beep, check for battery voltage between instrument harness 2-pin connector, terminal 2 (purple wire) and ground with the key switch ON. Also, check the tan/blue wire for continuity between pin 8 of the 8-pin connector and pin 1 of the 2-pin connector.
- If battery voltage is present at the purple wire and the tan/blue wire has continuity between

## ELECTRICAL AND IGNITION

### SystemCheck CIRCUIT TESTS

the two connectors, replace *SystemCheck* gauge.

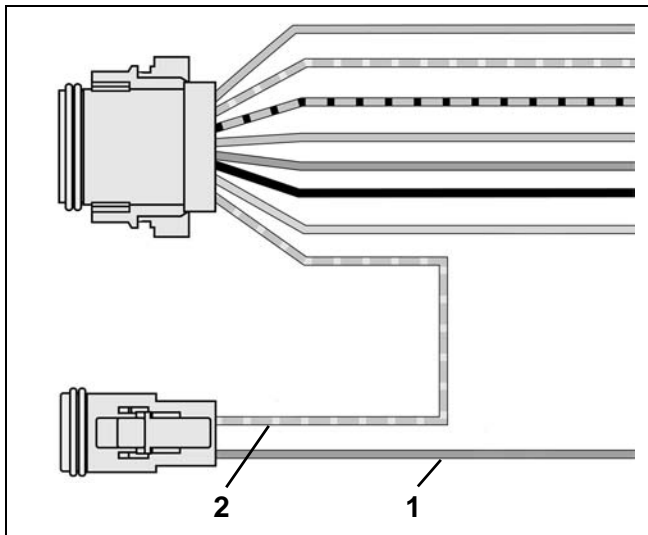

1. Purple wire
2. Tan/blue wire

DRC6280

Turn the key switch OFF and reconnect all disconnected circuits.

### CHECK ENGINE Circuit Test

Separate the 6-pin *SystemCheck* connector of MWS instrument harness from engine harness. Black wire (pin 3) must be grounded.

Using a jumper wire, connect tan/orange wire (pin 2) to a clean engine ground.

Turn the key switch ON. After the normal self-test sequence, the CHECK ENGINE light should stay on.

- If the CHECK ENGINE light is not on, test circuit for continuity. Check continuity of the MWS instrument harness (tan/orange wire).
- Check continuity of the engine wire harness between terminal 2 (tan/orange wire) of the *SystemCheck* connector and pin 17 of the *EMM* J1-A connector.

Turn the key switch OFF and reconnect all disconnected circuits.

### WATER TEMP/ HOT Circuit Test

The tan wire of engine harness and the MWS harness receives a signal from the *EMM*. The *EMM* receives information from the temperature sensor on the cylinder head.

Using a jumper wire, connect tan wire (pin 6) of the engine harness connector to a clean engine ground.

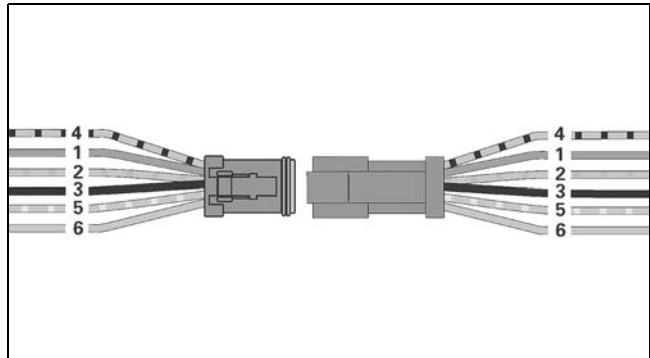

002079

Turn the key switch ON. After the normal self-test sequence, the gauge WATER TEMP / HOT indicator should stay on.

- If LED is not on, test circuit for continuity. Test for continuity of both the engine harness (tan wire) and the MWS instrument harness (tan wire).

Turn the key switch OFF and reconnect all disconnected circuits.

**IMPORTANT:** To test the temperature sensor itself, refer to **Engine Temperature Sensor Test** on p. 96.



## LOW OIL Circuit Test

Turn the key switch ON. Using a jumper wire, connect tan/black wire (pin 4) of the engine harness connector to a clean engine ground. The LOW OIL light should turn on after 40 seconds.

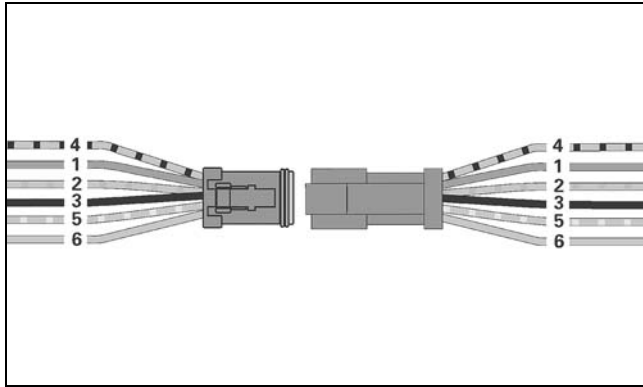

002079

If the LOW OIL light does not turn on after connecting the terminal to ground, test circuit for continuity.

Turn the key switch OFF and reconnect all disconnected circuits.

## NO OIL Circuit

Separate the 6-pin *SystemCheck* connector of MWS instrument harness from engine harness. Black wire (pin 3) must be grounded.

Using a jumper wire, connect tan/yellow wire (pin 5) to a clean engine ground.

Turn the key switch ON. After the normal self-test sequence, the NO OIL light should stay on.

- If the NO OIL light is not on, test circuit for continuity. Test for continuity of the MWS instrument harness (tan/yellow wire).
- Test for continuity of the engine wire harness between terminal 5 (tan/yellow wire) of the *SystemCheck* connector and pin 24 of the *EMM* J1-A connector.

Turn the key switch OFF and reconnect all disconnected circuits.

## TACHOMETER CIRCUIT TESTS

Check voltage at the battery. Use this reading as a reference for battery voltage.

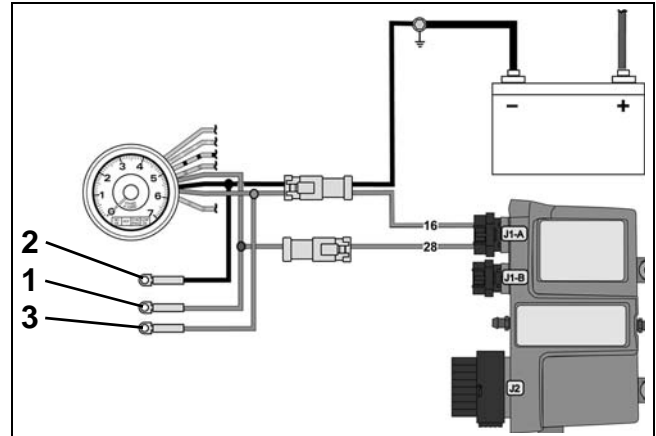

006551

1. Purple lead
2. Black lead
3. Gray lead

Connect the red meter lead to the tachometer purple wire and the black meter lead to the tachometer black wire (key ON, outboard NOT running).

- If meter shows battery voltage, go to next step.
- If meter shows less than battery voltage, check the purple, red/purple, and black wiring circuits; fuse, key switch, and battery connections.

Disconnect gray and black wires at tachometer. Set *Fluke* 29 Series II meter, or equivalent, to Hz scale. Connect meter between gray wire and black wire. With outboard running at 1000 RPM, meter should indicate 90 to 105 Hz.

- If meter reads 90 to 105 Hz, replace tachometer.
- If meter reads low or no signal, confirm output on gray wire at pin 16 of *EMM* J1-A connector.
  - Reading OK – Check condition of tachometer circuit (gray wire). Repair as needed.
  - Reading not OK – Check connection at *EMM*; replace faulty *EMM*.

# FLYWHEEL AND STATOR SERVICING

**IMPORTANT:** Weak flywheel magnets can cause low alternator output and affect outboard performance. Weak flywheel magnets can also cause low readings on ignition test equipment, such as a peak-reading voltmeter, which might cause unnecessary parts replacement.

An accurate test of alternator output can help determine the flywheel's condition. Refer to **CHARGING SYSTEM TESTS** on p. 98.

## Flywheel Removal

**⚠ WARNING**

To prevent accidental starting while servicing, disconnect the battery cables at battery.

Remove the recoil starter assembly (rope start models). Refer to **RECOIL STARTER REMOVAL** on p. 363.

Remove the electrical cover from flywheel cover.

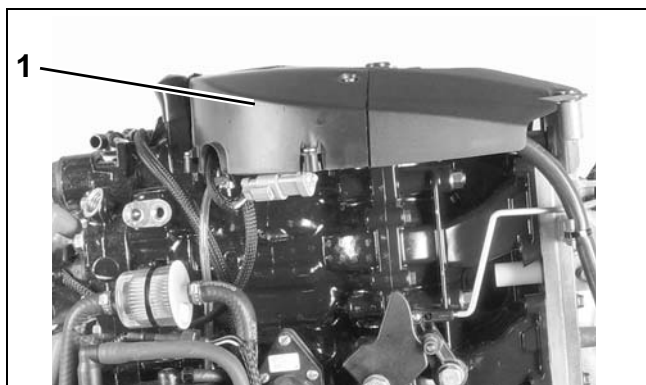

1. Electrical cover

002084

Disconnect wiring harness and remove wiring from cover.

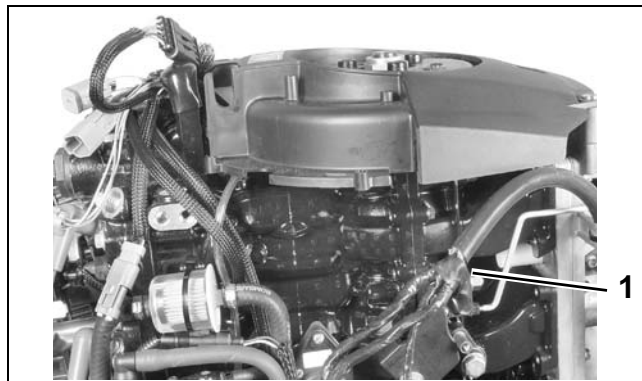

1. MWS harness

002086

Remove fuse holder from flywheel cover.

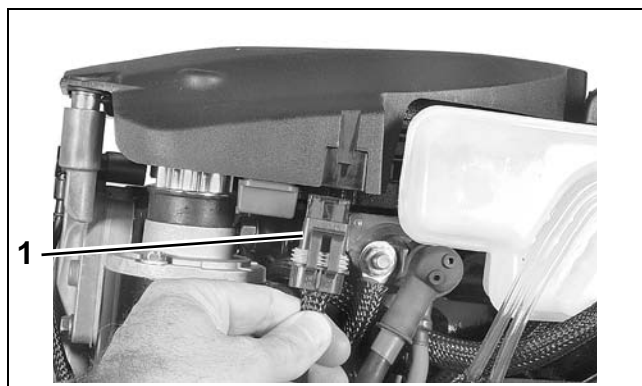

1. Fuse holder

002094

Lift flywheel cover to remove.

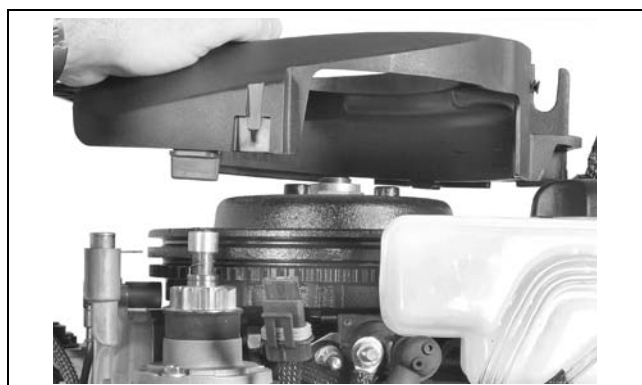

002087

Use Flywheel Holder, P/N 771311, or equivalent, and a 1 5/16 in. socket to remove flywheel nut. Discard flywheel nut.

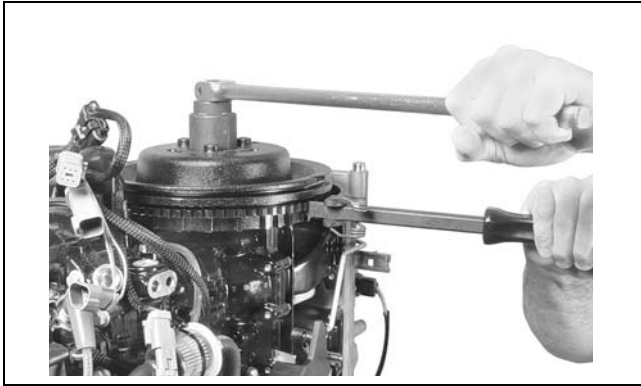

002088

Apply *Moly Lube* grease to the threads of the puller pressing screw, P/N 307637, and the center hole of the crankshaft.

Assemble the following components from Universal Puller Set, P/N 378103:

- Body, P/N 307636
- Screw, P/N 307637
- Handle, P/N 307638
- Three screws P/N 309492
- Three washers, P/N 307640

Put the puller on flywheel with body flat side up. Attach the puller body with the three shoulder screws and washers. Hold puller body with handle, and tighten pressing screw until flywheel releases. Turn the center screw and lift the flywheel off of the crankshaft.

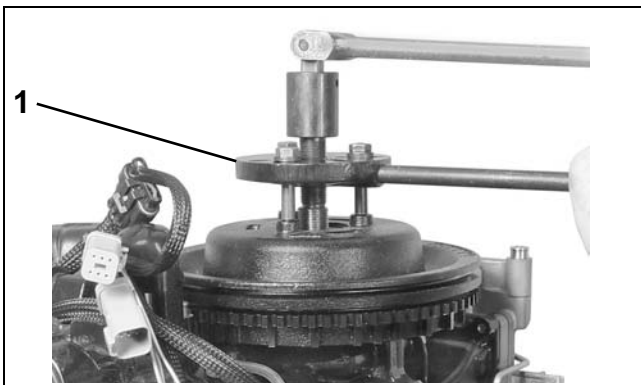

1. Universal puller

002089

## Stator Service

Disconnect stator harness connector.

Remove three allen head screws to remove stator.

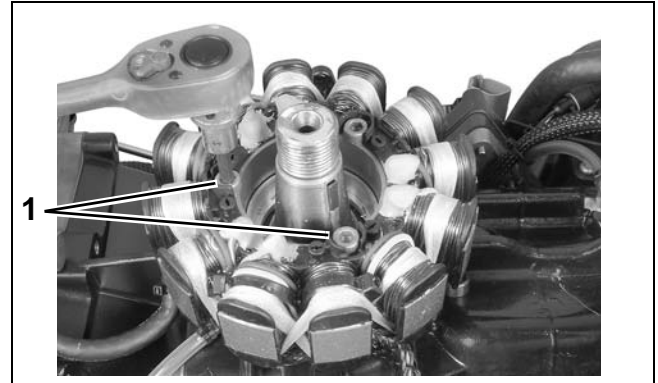

1. Stator screws

006486

To install stator, position stator on cylinder block. Apply *Nut Lock* to screw threads. Install screws and tighten in crossing pattern to a torque of 84 to 106 in. lbs. (9.5 to 12 N·m).

6

## Flywheel Installation

### ⚠ CAUTION

To avoid injury, keep hands and fingers clear from underside of flywheel. Flywheel can snap toward stator with great magnetic force.

Install the outer edge of flywheel key parallel with centerline of crankshaft.

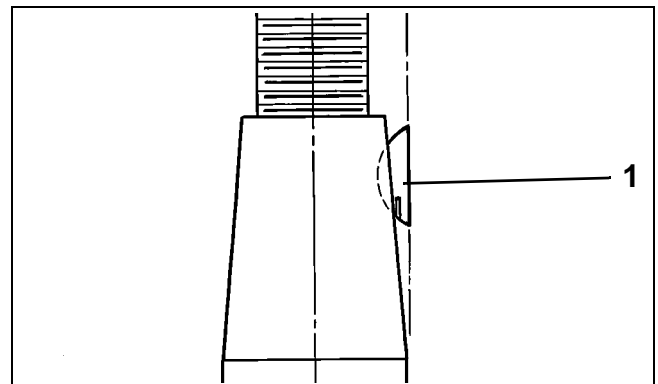

1. Flywheel key

DRC2116

## ELECTRICAL AND IGNITION

### IGNITION COIL SERVICING

Thoroughly clean the crankshaft and flywheel tapers with *Cleaning Solvent* and let dry.

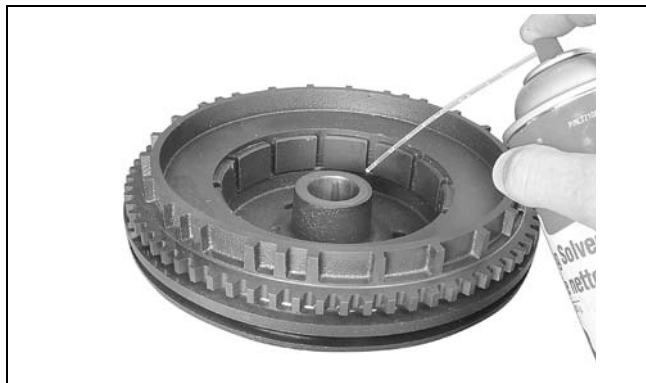

002093

Align the flywheel keyway and install flywheel. Coat the threads of flywheel nut with *Triple-Guard* grease. Install the washer and nut and tighten to a torque of 100 to 115 ft. lbs. (136 to 156 N·m).

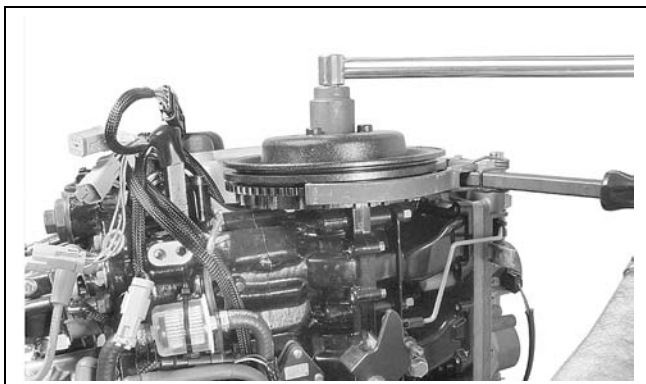

002090

Replace flywheel cover and recoil starter (rope start models).

**IMPORTANT:** Check ignition timing after flywheel removal or replacement. Refer to **TIMING ADJUSTMENTS** on p. 113.

## IGNITION COIL SERVICING

### Ignition Coil Removal

Remove spark plug lead from ignition coil and disconnect ignition coil electrical connector.

Remove two ignition coil retaining screws.

Do not lose the rubber washers between coil and bracket.

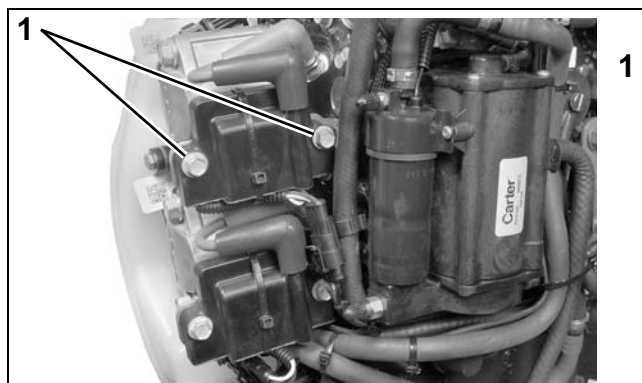

1. Screws

008187

### Ignition Coil Installation

Install one rubber washer on each screw and install screw through ignition coil.

Install remaining rubber washers on screws between coil and bracket.

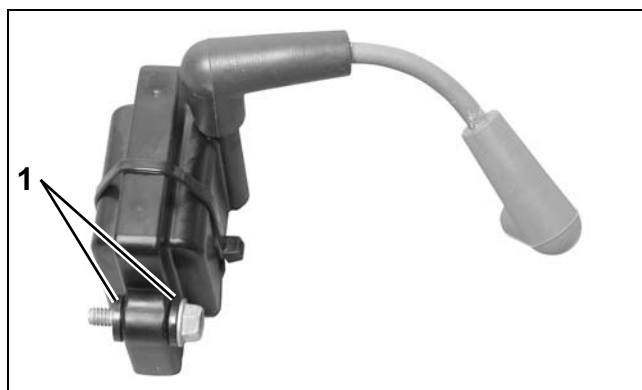

1. Rubber washers

008188

Install coil on bracket. Tighten screws to a torque of 60 to 84 in. lb. (7 to 9.5 N·m).

Install spark plug lead on ignition coil and connect ignition coil electrical connector.

# TIMING ADJUSTMENTS

## Timing Pointer

**⚠ WARNING**

To prevent accidental starting while servicing, disconnect the battery cables at the battery. Twist and remove all spark plug leads.

The timing pointer must be adjusted to indicate top dead center (TDC) of the number 1 piston. This reference to the position of the number 1 piston is used to synchronize the electronic timing controlled by the *EMM* with the mechanical position of the number 1 piston.

Always check timing pointer adjustment before using the *Evinrude Diagnostics* software Timing Verification procedure.

Remove spark plugs. Rotate the flywheel clockwise to approximately 30° ATDC.

Install Piston Stop Tool, P/N 342679, into the spark plug hole of the number 1 cylinder.



1. Piston stop tool

006493

Rotate flywheel **counterclockwise** until the number 1 piston contacts the tool. Keep pressure on the flywheel to position the piston firmly against

the tool. Mark the flywheel directly across from the pointer. Label this mark "A."

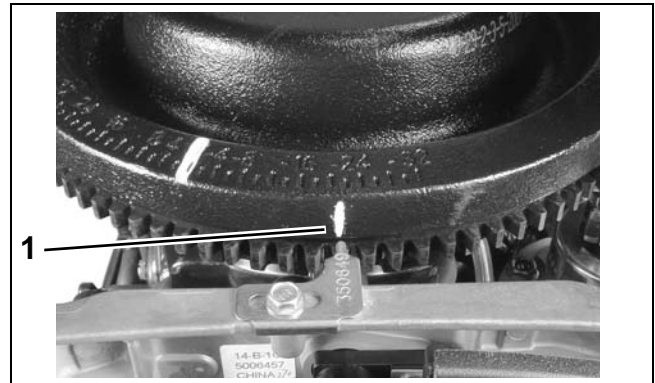

1. Timing pointer

006552

Rotate the flywheel **clockwise** until the piston contacts the tool. Mark the flywheel directly across from the pointer. Label this mark "B." Rotate flywheel **counterclockwise** slightly to release tool then remove it from spark plug hole.

Use a flexible measuring device, such as a piece of string, to find the exact center between marks "A" and "B." Measure along the edge of the flywheel. Mark and label the center point "C."

If mark "C" and the cast-in TDC boss on flywheel are in alignment, the timing pointer is in the correct location.

If the pointer alignment is NOT correct, rotate the flywheel **clockwise** to align the mark "C" with the pointer. Hold the flywheel in this position. Loosen the pointer retaining screw and adjust the pointer

## ELECTRICAL AND IGNITION TIMING ADJUSTMENTS

location to align with the cast-in TDC boss on the flywheel. Tighten retaining screw.

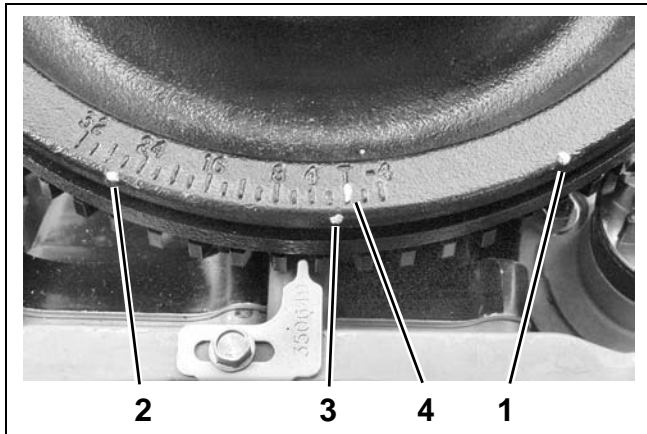

1. Mark "A"
2. Mark "B"
3. Mark "C"
4. TDC boss

002092

Repeat the entire adjustment process to make sure pointer is aligned correctly.

Install spark plugs. Refer to Spark Plug **Indexing** on p. 42.

### Timing Verification

Use *Evinrude Diagnostics* software to synchronize the mechanical timing of the outboard with the electronic timing of the *EMM*.

Start the outboard.

Use the *Settings/Ignition Timing* screen of the diagnostics software and follow the on-screen instructions.

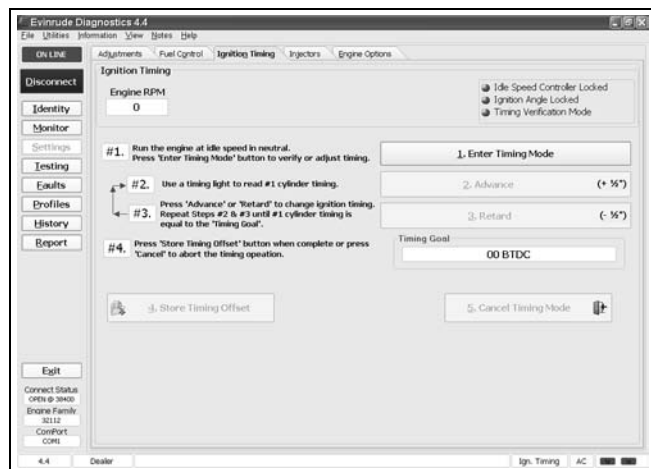

Ignition Timing Screen

008085

Check ignition timing after any of the following procedures:

- Powerhead replacement
- Crankshaft replacement
- Flywheel removal or replacement
- CPS replacement
- *EMM* replacement
- *EMM* software replacement (reprogramming)

**IMPORTANT:** Make sure the timing pointer is set and the outboard reaches operating temperature before making any timing adjustments.

### TPS Calibration

Use *Evinrude Diagnostics* software to tell the *EMM* what throttle position sensor voltage is when the throttle plates begin to open.

Set TPS Calibration after replacing or adjusting any throttle body or throttle linkage parts.

Remove the lower engine covers and air silencer.

Do NOT start the outboard.

On the *Settings/Adjustments* screen of the diagnostics software, click the "Set TPS Calibration" button.

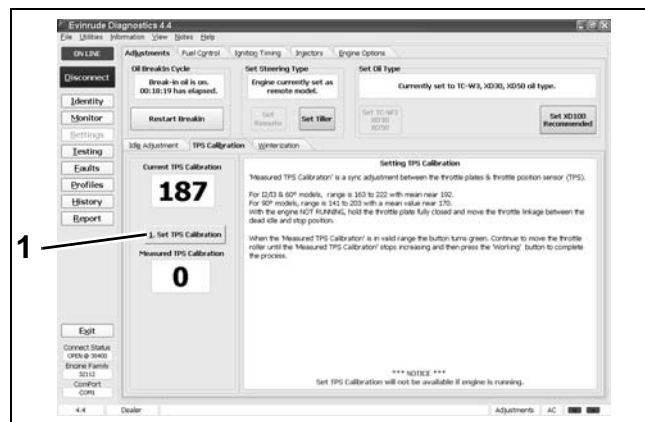

1. TPS Calibration button

008086

While holding the throttle plates closed, advance the throttle linkage until it stops. The *Measured TPS Calibration* field on the screen will increase.

Click the *Working* button in the software to calibrate the TPS.

Install the air silencer and lower engine covers.

# ELECTRIC STARTER SERVICING

## Starter Removal

**IMPORTANT:** Do not clean the starter drive while the starter motor and drive are installed on the powerhead. The cleaning agent could drain into the starter motor, washing dirt from the drive into the starter bearings and commutator.

Disconnect the battery cables at the battery.

Remove lower motor covers and air silencer. Refer to **Lower Cover Removal** on p. 50.

Remove the starter positive (+) cable from post on starter. Remove the battery negative cable (-) from the double-ended stud.

Remove two starter mounting screws and double-ended stud. Remove the starter.

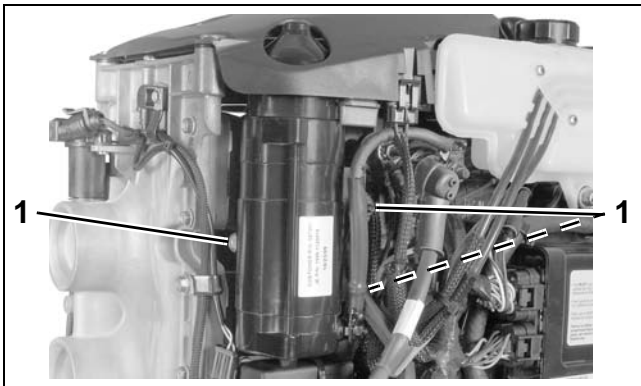

1. Screws

008189

## Starter Installation

Apply *Triple-Guard* grease to the threads of the two starter screws, the double-ended stud, and also to the washers.

Position the starter and install the screws and washers. Tighten screws to a torque of 168 to 192 in. lbs. (19 to 21 N·m).

Attach starter positive (+) cable to post with lock washer and nut; tighten securely.

Install the battery negative cable (-) to the double-ended stud.

Coat connections with *Black Neoprene Dip*.

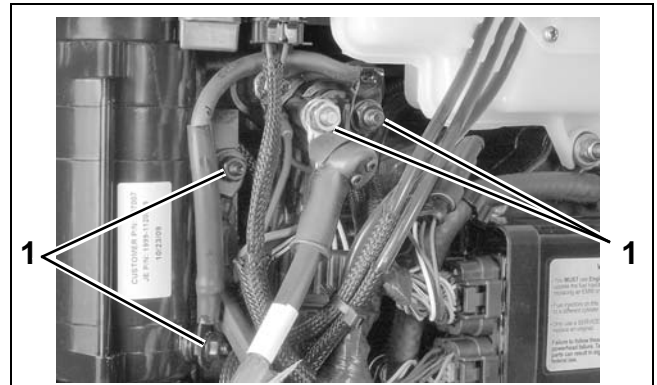

1. *Black Neoprene Dip*

008190

# CONNECTOR SERVICING

## DEUTSCH Connectors

**IMPORTANT:** *Electrical Grease* is recommended. Incorrect grease application can cause electrical or warning system problems.

To disconnect the connector, press the latch and pull the connectors apart.

To connect the connector, confirm that the seal is in place. Clean off any old grease and dirt from connectors. Apply a light coat of *Electrical Grease* to seal only. Push connectors together until latched.

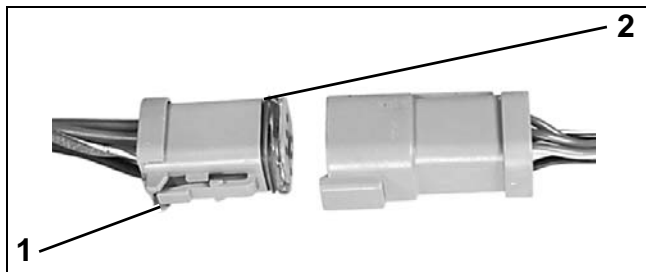

1. Latch  
2. Seal  
42079A

### Terminal Removal

Use hook-end of Connector Service Tool, P/N 342667, to pull out wedge from receptacle, or use other end of tool to pry out wedge from plug. Use needle-nose pliers to remove wedge from 3-pin receptacle.

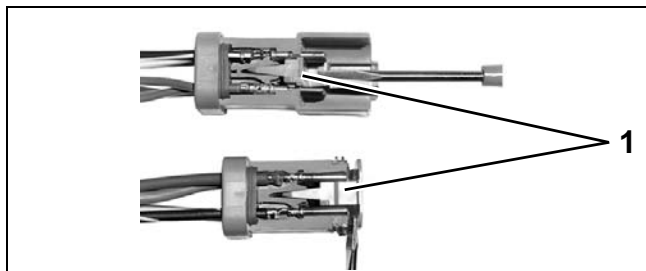

1. Wedge  
42327

Release terminal latch and gently pull on wire.

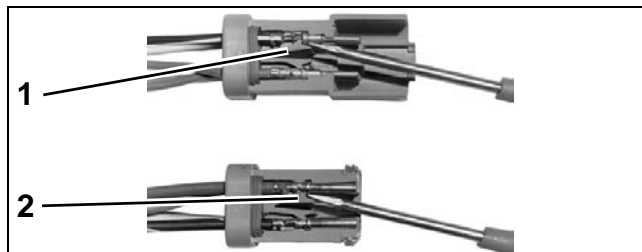

1. Terminal latch (plug)  
2. Terminal latch (receptacle)  
42329

### Terminal Installation

Push terminal through seal until it locks into place. Fill connector with *Electrical Grease* to 1/32 in. (0.8 mm) below ledge or end of plug.

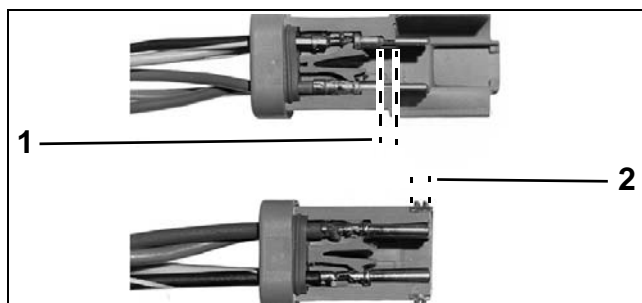

1. Ledge of plug  
2. End of plug  
42330

Push wedge in until latched. Wedge in 2-pin receptacle is not symmetrical; position latch shoulders next to terminals.

### Crimping Terminals

Strip insulation back 3/16 in. (5 mm). Place terminal in 18-gauge notch of Crimping Pliers, P/N 322696. Position end of wire strands in terminal past wire crimp area, and position end of insulation past insulation crimp area. Capture all wire strands in crimp; leave no loose strands. Crimp wire securely. Do not solder. Crimp insulation in 14/16-gauge notch of crimping pliers.

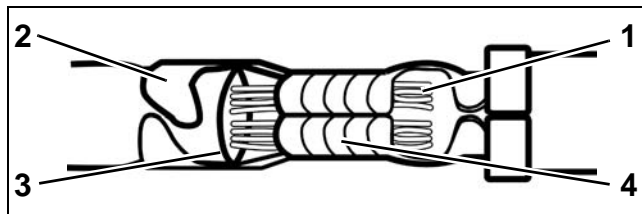

1. End of wire strands  
2. Insulation crimp area  
3. End of insulation  
4. Wire crimp area  
DRC6205



## AMP Connectors

**IMPORTANT:** Always use the appropriate meter test probes and adapters when testing components fitted with these terminals. Electrical grease is NOT used on AMP connectors.

### SUPERSEAL 1.5

#### Disconnect

Lift latch. Pull connectors apart.

#### Connect

Confirm the seal is in place. Push connectors together until latched.

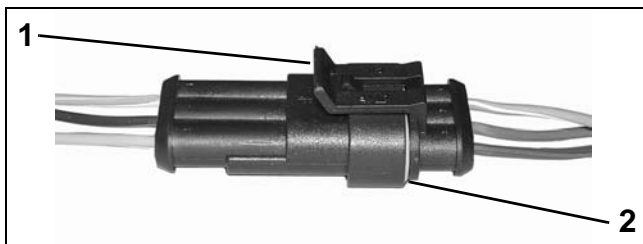

1. Latch  
2. Seal  
002448

#### Terminal Removal

Use Secondary Lock Tool, P/N 777078, to release anti-backout device of connector housing. Next, use Primary Lock Tool, P/N 777077, to release locking tab of connector housing. Release locking tab and pull on wire to remove from connector housing.

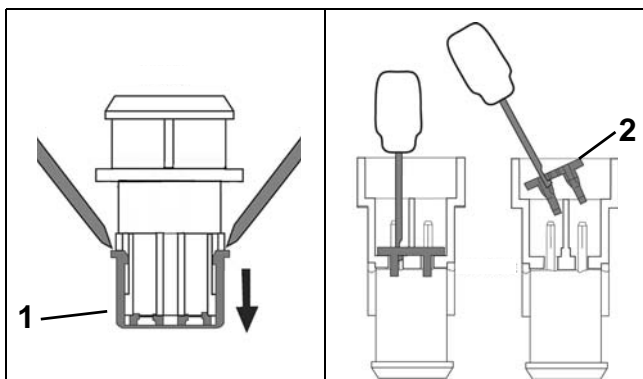

1. Anti backout device, plug  
2. Anti backout device, receptacle  
002449  
002450

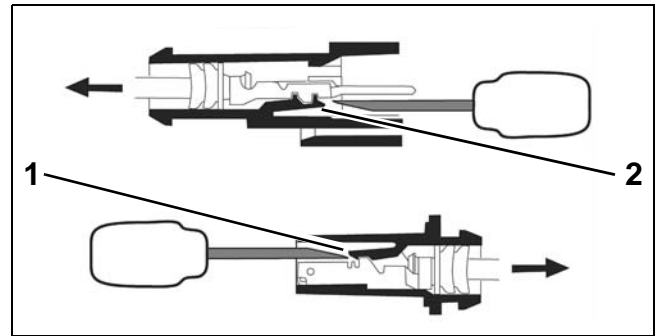

1. Locking tab, plug  
2. Locking tab, receptacle  
002447

#### Terminal Installation

Align terminal with connector housing. Push connector and seal into housing until seated.



1. Terminal and seal  
002451

Align anti-backout device with connector housing and terminals. Use Secondary Lock Installer, P/N 777079, to seat device in connector.

#### Crimping Terminals

Crimping Superseal 1.5 terminals requires AMP Crimp Tool with dies, P/N 777281.

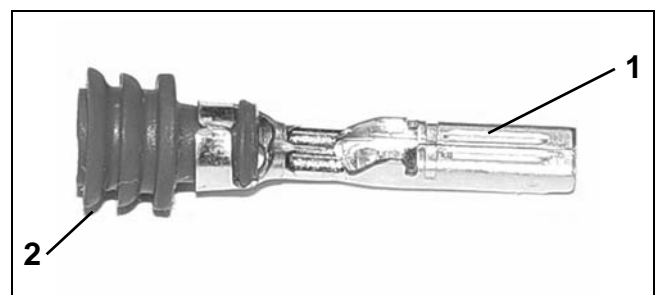

1. Terminal  
2. Seal  
002452

## ELECTRICAL AND IGNITION CONNECTOR SERVICING

### **SUPER SEAL**

The J1-A and J1-B connectors of the *EMM* are *AMP Super Seal* connectors.

#### **Disconnect**

Depress BOTH latches and pull connector from plug.

#### **Connect**

Push connector into plug until latches engage.

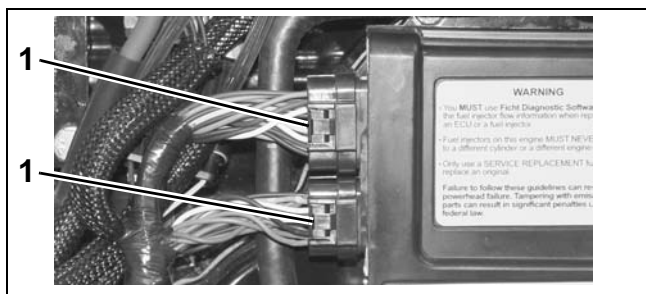

1. Latch

002118

#### **Terminal Removal**

Open lock mechanism and remove terminal from connector housing.

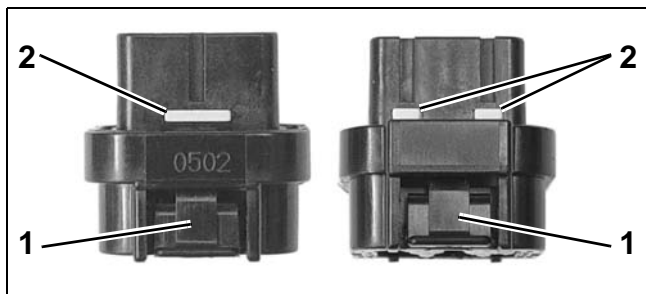

1. Latch

2. Lock mechanism

002453

#### **Terminal Installation**

Push terminal through seal until it is seated in connector housing. Close lock mechanism.

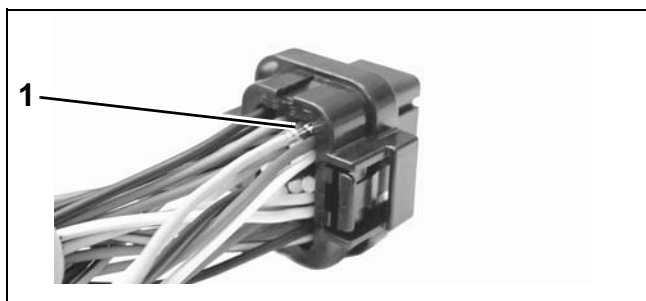

1. Terminal

002454

### **POWER TIMER SERIES**

The J2 connector of the *EMM* is an *AMP Power Timer Series* connector.

#### **Disconnect**

Use a screw driver to open latch. Pull connector from plug.

#### **Connect**

Push connector until seated in plug. Close latch completely.

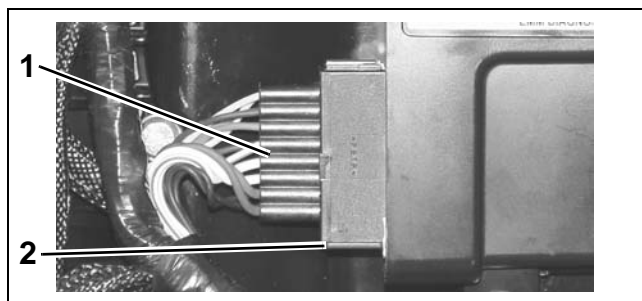

1. J2 connector

2. Latch (closed)

002120

#### **Terminal Removal**

Use Terminal Release Tool, P/N 351413, to release BOTH locking mechanisms of connector. Pull terminal from housing.

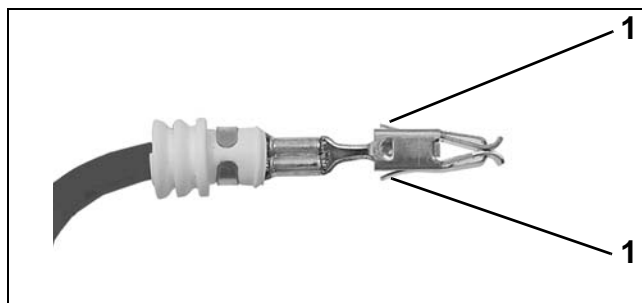

1. Locking mechanism(s)

002455

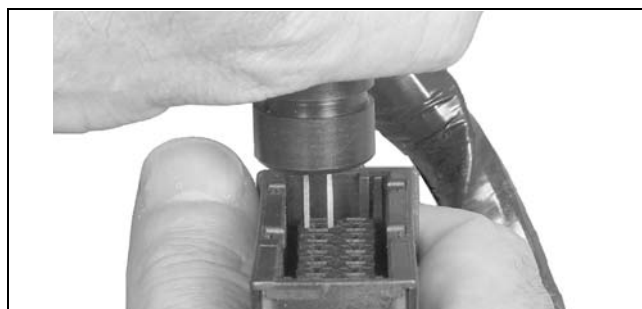

1. Terminal release tool

002313

### Terminal Installation

Align terminal with connector housing and push terminal with seal into connector housing until seated.

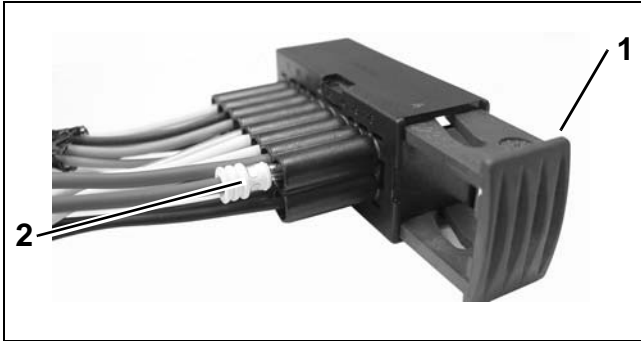

- 1. Latch
- 2. Terminal with seal

002456

### PackardConnectors

**IMPORTANT:** Always use the appropriate meter test probes and adapters when testing components fitted with these terminals.

#### Disconnect

Lift latch(s). Remove connector.

#### Connect

Confirm the seal is in place. Push connector onto housing until latched.

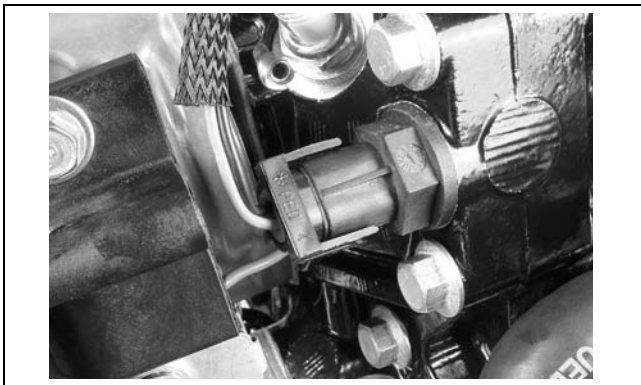

DSC02124

### Terminal Removal

A tab on the back side of the terminal engages a shoulder in the connector housing to hold the terminal in place. The terminal is removed by releasing the tab and then pushing the terminal and wire through connector housing.

Insert a thin tool into the connector above the terminal to release tab.

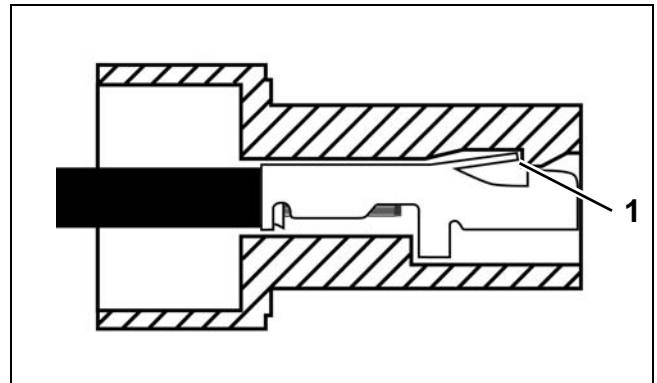

- 1. Tab

DRC5940a

### Terminal Installation

Install wire gasket on wires and feed wires through the correct terminal position of the connector housing. Terminal is crimped onto wire and then pulled back into connector housing until locking tab engages and terminal is seated.



002304

### Crimping Terminals

Strip insulation back 3/16 in. (5 mm). Position end of wire strands in terminal past the wire crimp area and the end of insulation in the insulation crimp area of the terminal.

Capture all wire strands in crimp; leave no loose strands. Crimp wire and insulation securely using crimping pliers.



# FUEL SYSTEM

## TABLE OF CONTENTS

SERVICE CHART .....	122
FUEL SYSTEM HOSE ROUTING .....	126
FUEL SYSTEM CIRCUIT DIAGRAMS .....	128
FUEL SYSTEM REQUIREMENTS .....	130
REGULATIONS AND GUIDELINES .....	130
PORTABLE FUEL TANKS .....	130
FUEL FLOW REQUIREMENTS .....	130
FUEL REQUIREMENTS .....	131
COMPONENTS .....	132
FUEL LIFT PUMP .....	132
FUEL FILTER .....	132
VAPOR SEPARATOR .....	132
FUEL CIRCULATION PUMP .....	134
FUEL MANIFOLDS .....	134
FUEL INJECTORS .....	134
FUEL SYSTEM PRIMING .....	136
VENT LINE CLAMP .....	136
PRIMING THE FUEL SYSTEM .....	136
FUEL SYSTEM TESTS .....	137
FUEL SYSTEM PRESSURE TEST .....	137
PRESSURE REGULATOR TEST .....	138
VAPOR SEPARATOR VENT CHECK .....	138
FUEL INJECTOR PRESSURE TEST .....	138
FUEL INJECTOR RESISTANCE TEST .....	139
CIRCULATION PUMP RESISTANCE TEST .....	139
LIFT PUMP PRESSURE TEST .....	139
LIFT PUMP VACUUM TEST .....	140
LIFT PUMP DIAPHRAGM TEST .....	141
ANTI-SIPHON VALVE TEST .....	141
FUEL COMPONENT SERVICING .....	142
RELIEVING FUEL SYSTEM PRESSURE .....	142
FUEL FILTER SERVICE .....	143
FUEL LIFT PUMP SERVICE .....	143
VAPOR SEPARATOR SERVICE .....	144
FUEL MANIFOLD SERVICE .....	145
FUEL INJECTOR SERVICE .....	146
INTAKE MANIFOLD SERVICE .....	149



# SERVICE CHART

## 2-CYLINDER MODELS: INJECTORS, VAPOR SEPARATOR, FUEL PUMP

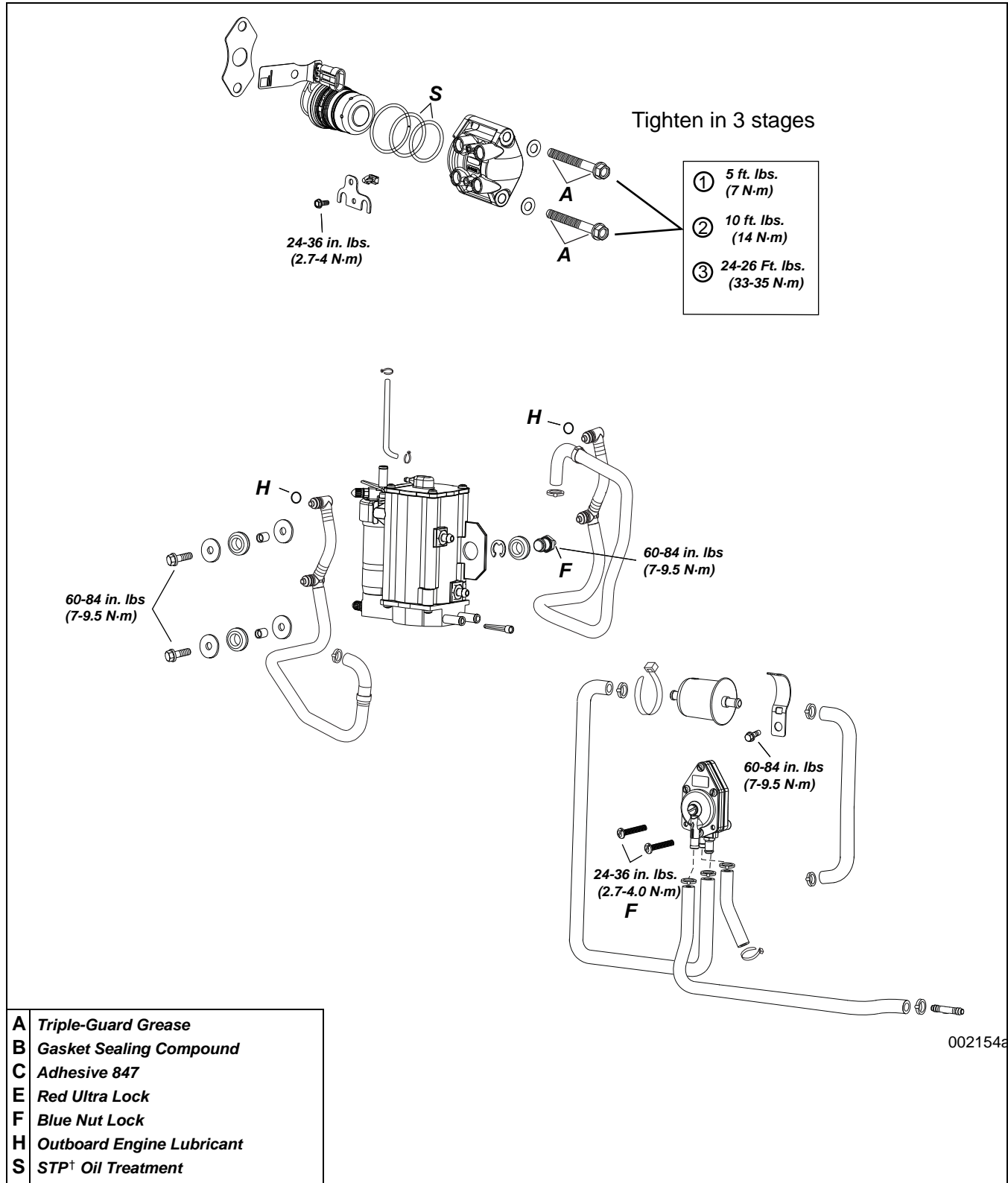

**2-CYLINDER MODELS: REED PLATE ASSEMBLY AND THROTTLE BODY**

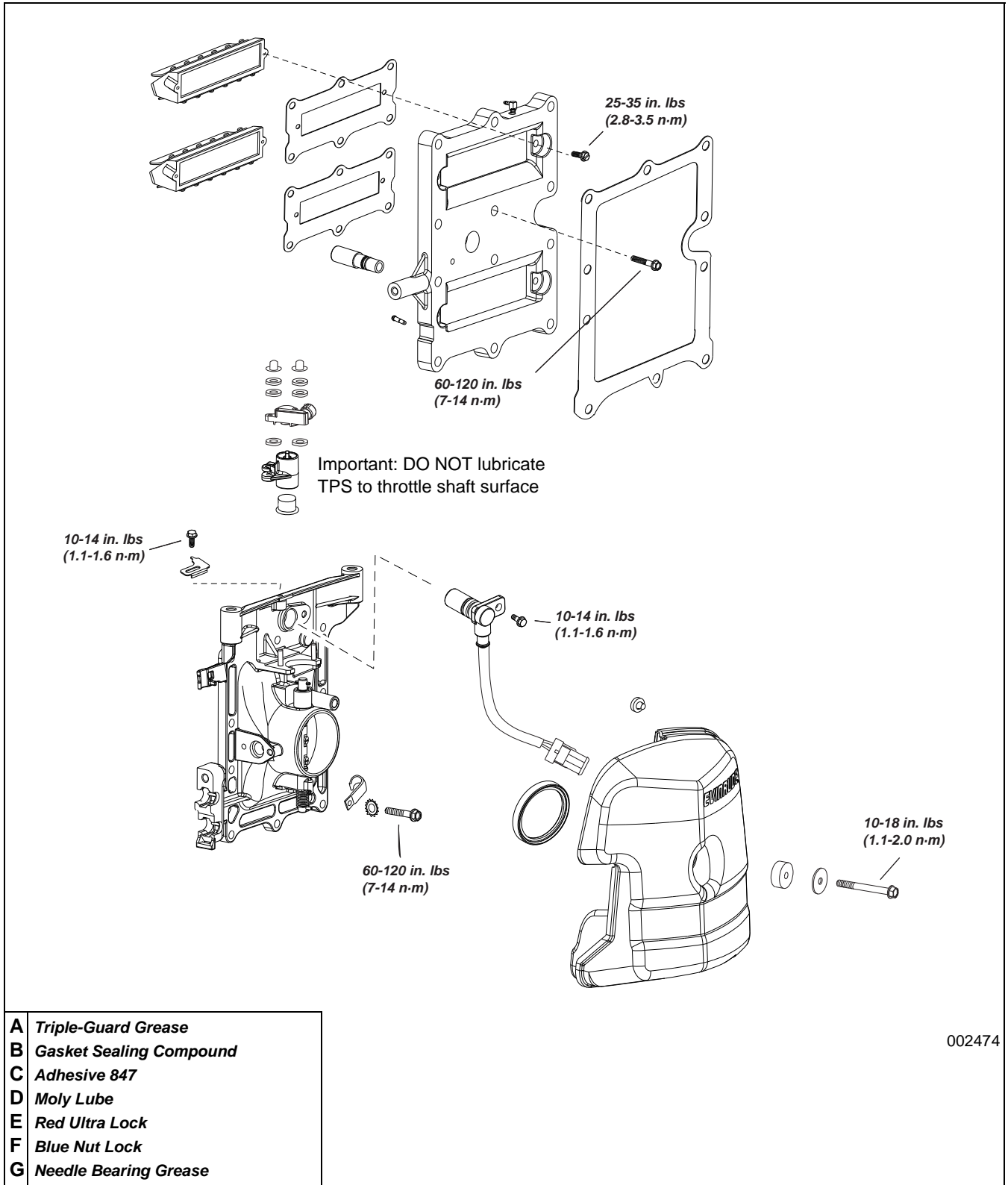

# FUEL SYSTEM SERVICE CHART

## 3-CYLINDER MODELS: INJECTORS, VAPOR SEPARATOR, FUEL PUMP

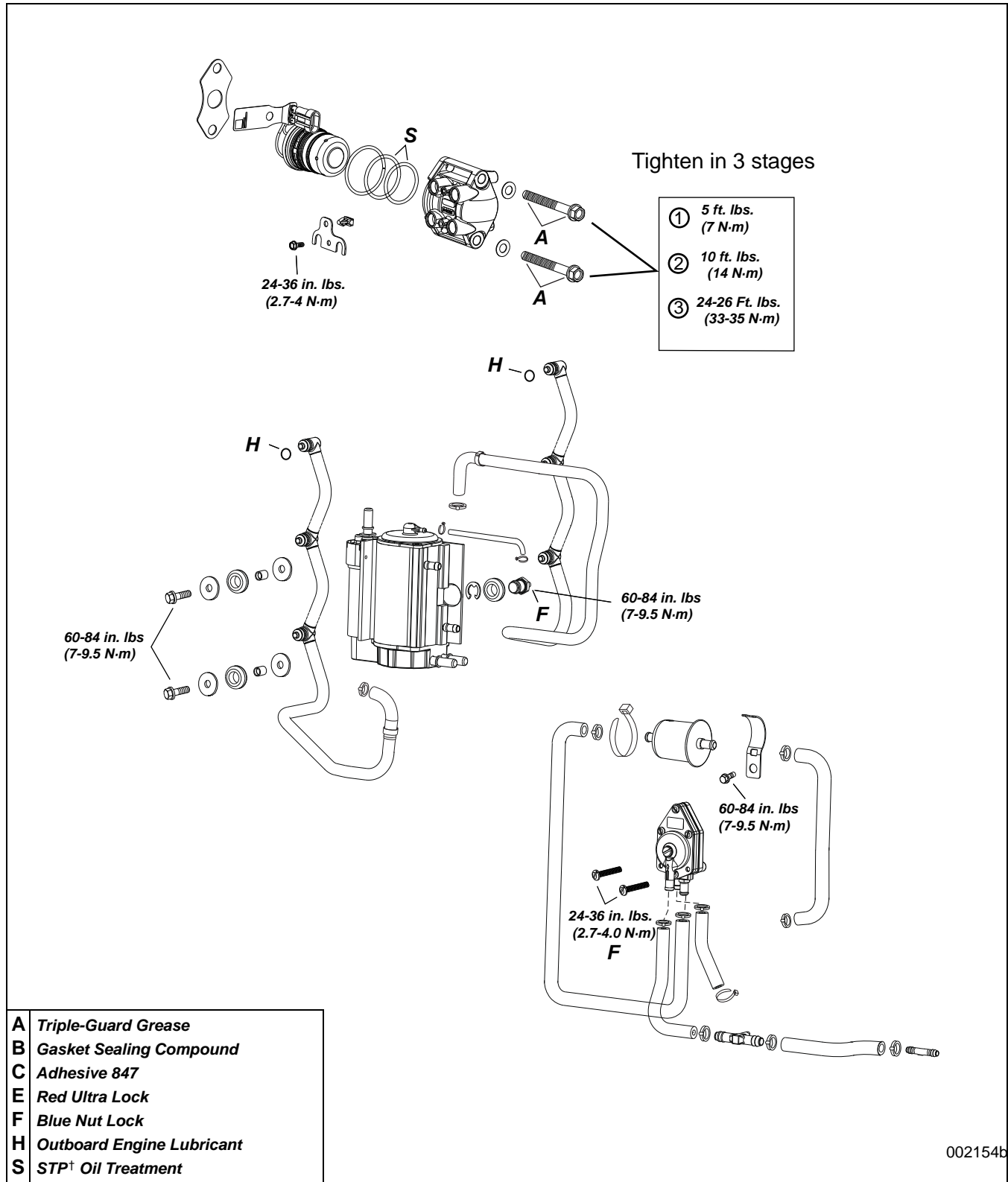

002154b



**3-CYLINDER MODELS: REED PLATE ASSEMBLY AND THROTTLE BODY**

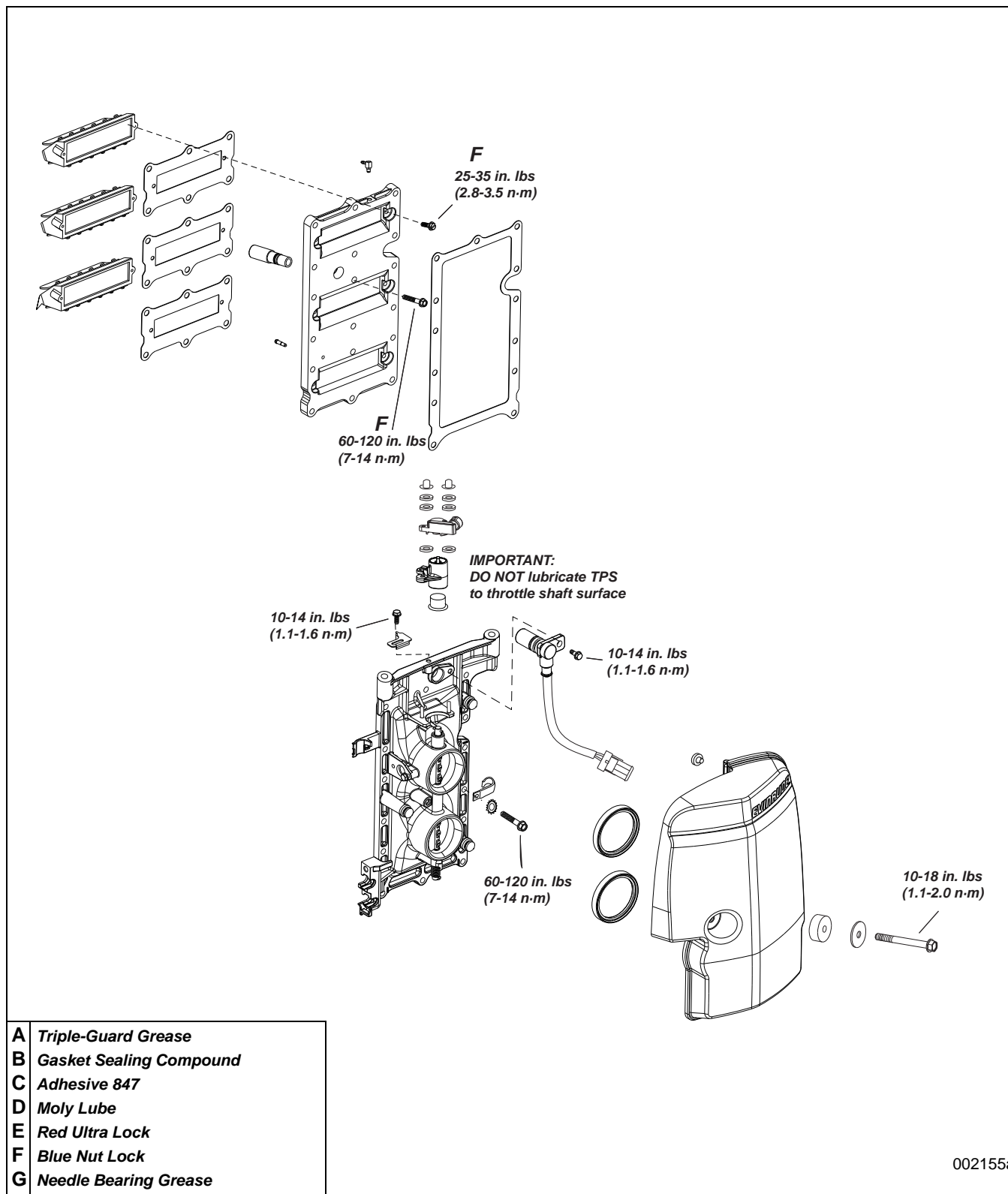

# FUEL SYSTEM HOSE ROUTING

2-CYLINDER MODELS

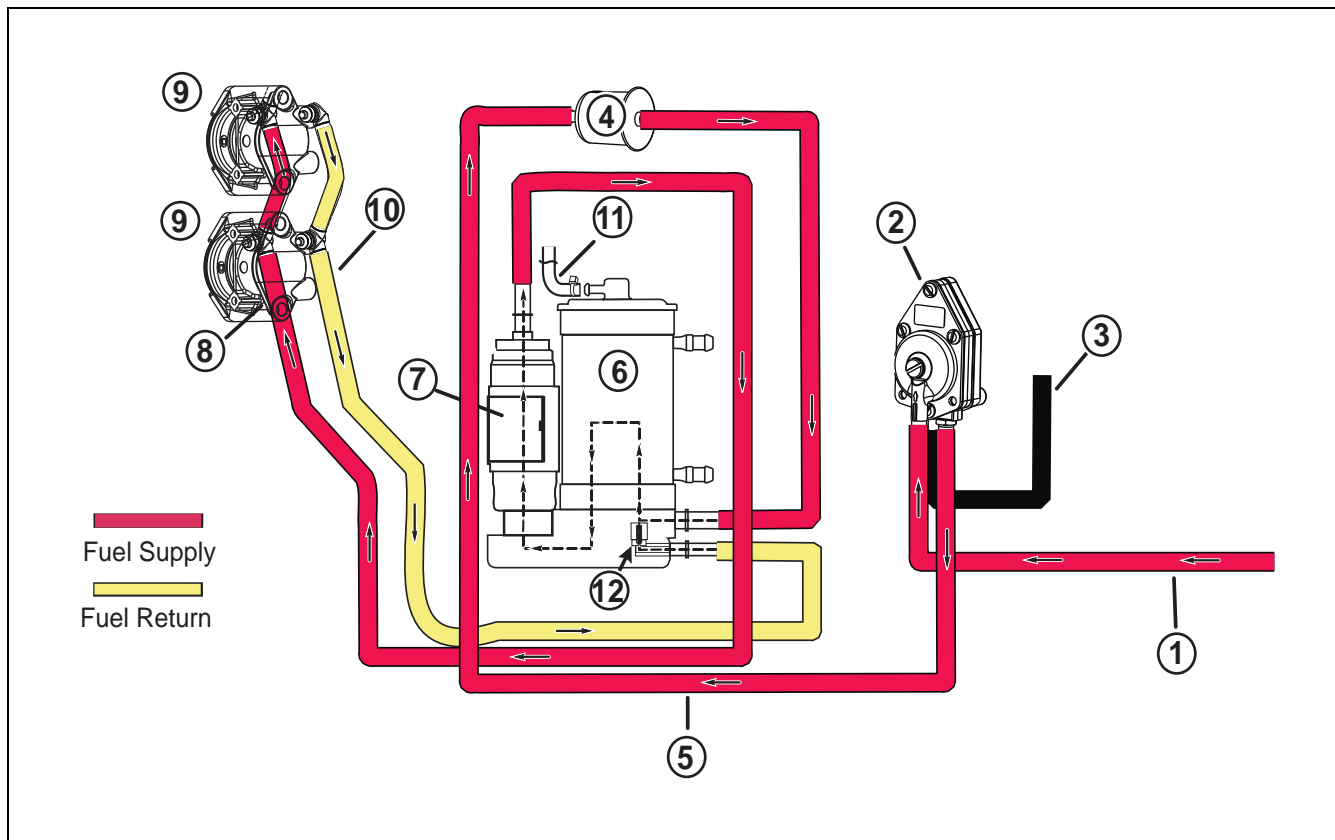

002148

1. Fuel supply from boat fuel system
2. Fuel lift pump (2 to 8 psi)
3. Pulse hose from cylinder/crankcase
4. Fuel filter
5. Fuel supply to vapor separator
6. Vapor separator
7. Electric fuel circulation pump (20 to 30 psi)
8. Fuel supply manifold
9. Fuel injector(s)
10. Fuel return manifold
11. Vent hose to intake manifold
12. Pressure regulator (high pressure)

3-CYLINDER MODELS

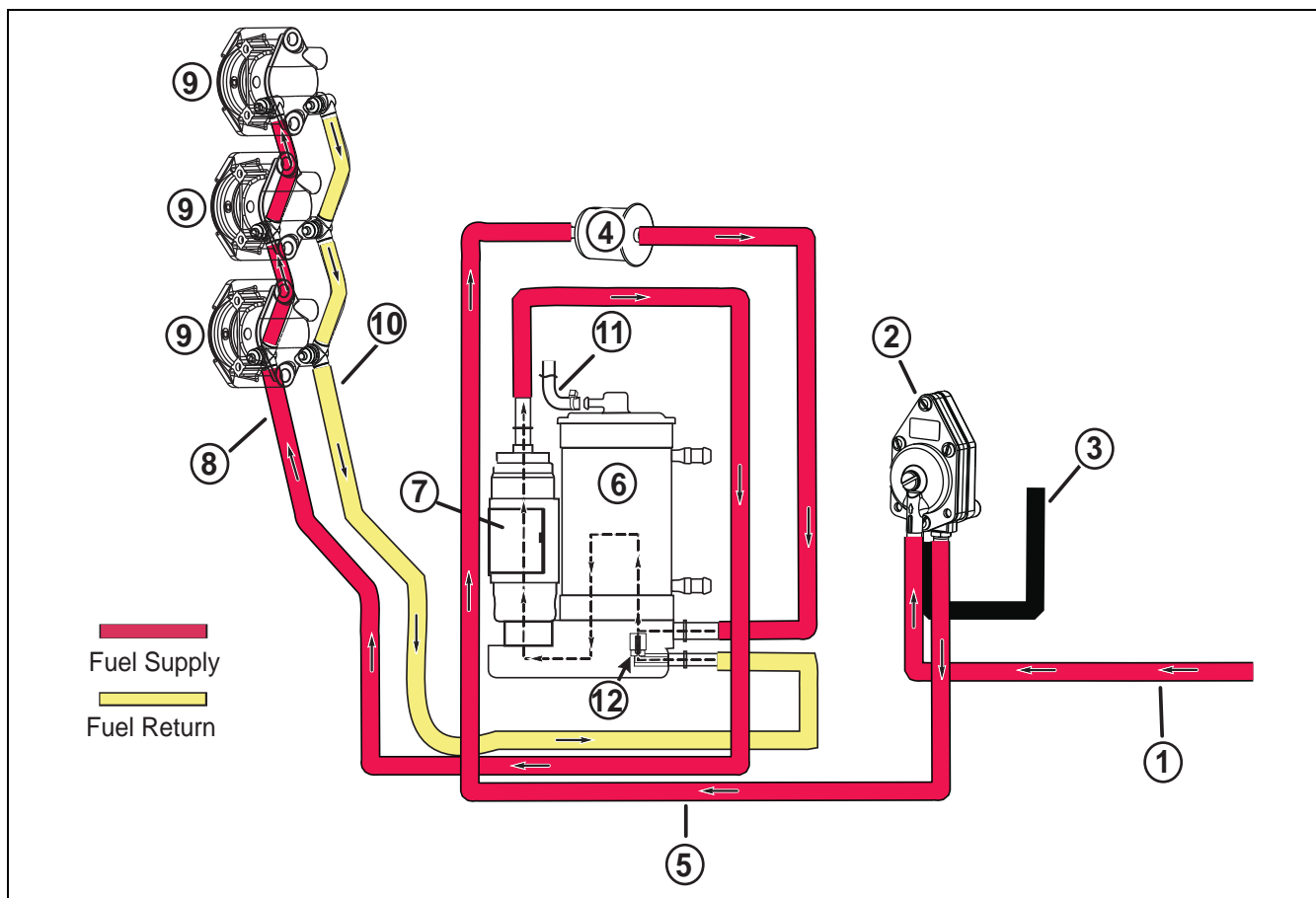

002148a

1. Fuel supply from boat fuel system
2. Fuel lift pump (2 to 8 psi)
3. Pulse hose from cylinder/crankcase
4. Fuel filter
5. Fuel supply to vapor separator
6. Vapor separator
7. Electric fuel circulation pump (20 to 30 psi)
8. Fuel supply manifold
9. Fuel injector(s)
10. Fuel return manifold
11. Vent hose to intake manifold
12. Pressure regulator (high pressure)

# FUEL SYSTEM CIRCUIT DIAGRAMS

2-CYLINDER MODELS

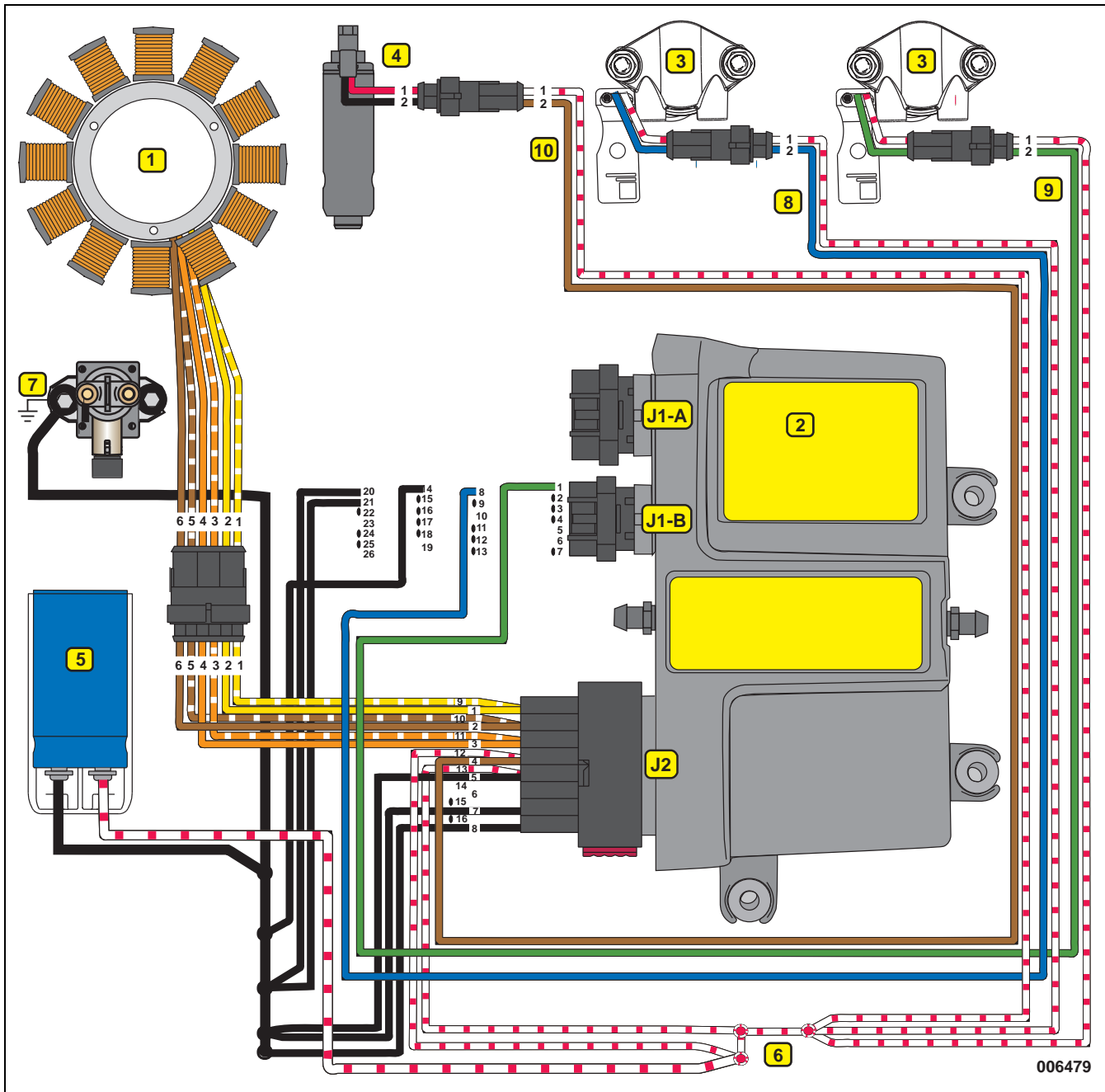

- |                          |                       |           |
|--------------------------|-----------------------|-----------|
| 1. Stator                | 5. Capacitor          | 9. GREEN  |
| 2. EMM                   | 6. WHITE/RED (55 V)   | 10. BROWN |
| 3. Fuel injector         | 7. BLACK ground wires |           |
| 4. Fuel circulation pump | 8. BLUE               |           |

3-CYLINDER MODELS

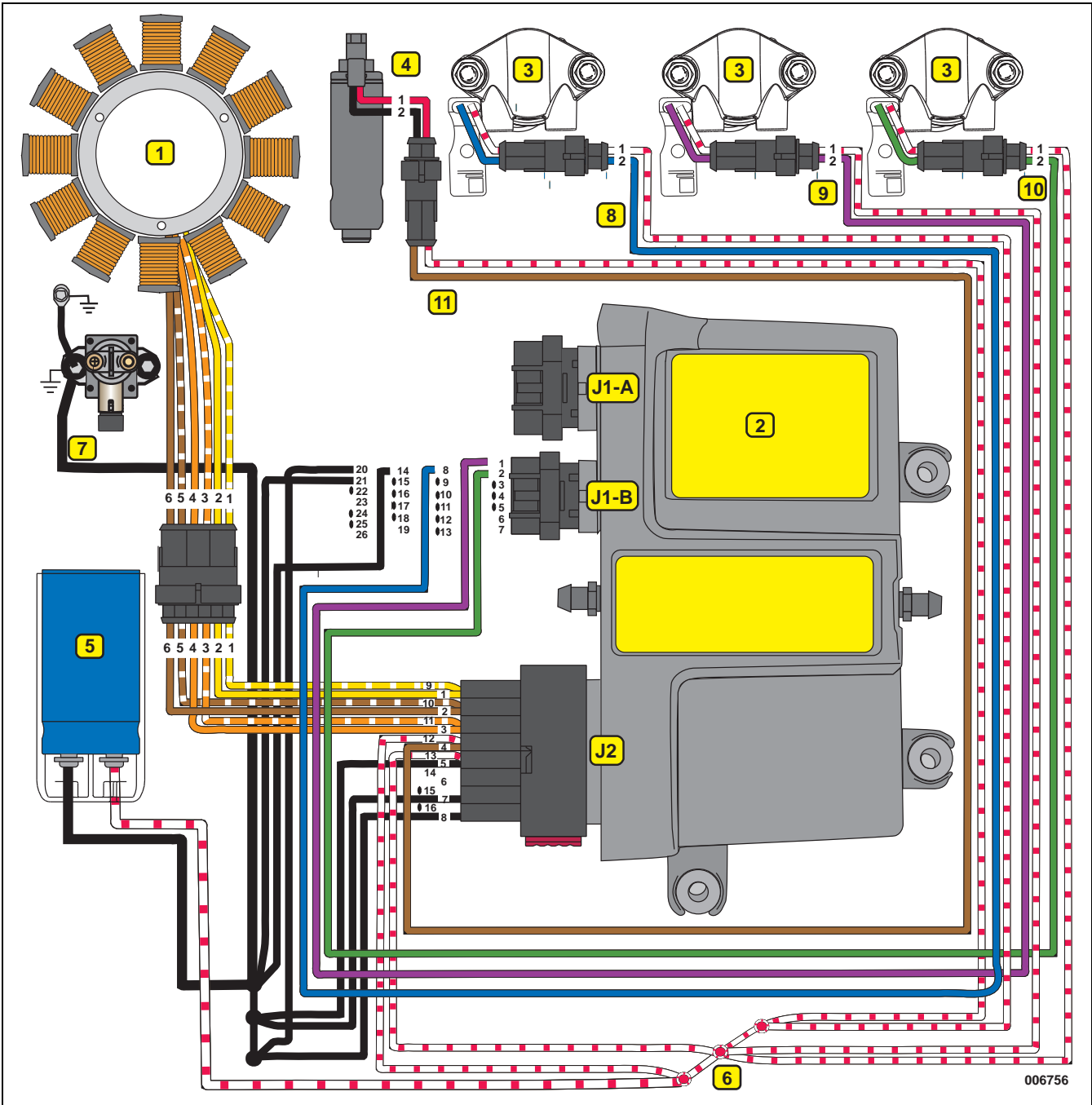

- |                          |                       |               |
|--------------------------|-----------------------|---------------|
| 1. Stator                | 5. Capacitor          | 9. PURPLE     |
| 2. EMM                   | 6. WHITE/RED (55 V)   | 10. GREEN (2) |
| 3. Fuel injector         | 7. BLACK ground wires | 11. BROWN     |
| 4. Fuel circulation pump | 8. BLUE               |               |

7

# FUEL SYSTEM REQUIREMENTS

## Regulations and Guidelines

Vessel manufacturer, and/or installer of an EPA certified outboard, must meet minimum specifications for boat fuel systems established by:

- U.S. Environmental Protection Agency (EPA)
  - 40 CFR 1045.112
  - 40 CFR 1060
- U.S. Coast Guard (USCG)
  - 33 CFR 183
- American Boat & Yacht Council (ABYC)
  - Standard H-24
  - Standard H-25.

## Portable Fuel Tanks

**⚠ WARNING**

If engine is equipped with a quick-disconnect fuel hose, you **MUST** disconnect the fuel hose from the engine and the fuel tank to prevent fuel leaks:

- Whenever the engine is **NOT** being used
- Whenever the engine is being trailered
- Whenever the engine is in storage.

**NOTE:** A small amount of fuel may be released when the fuel connector is disconnected.

Store portable fuel tanks in well-ventilated areas, away from heat sources and open flames. Close the vent screw of the fuel tank cap, if equipped, to prevent escape of fuel or fuel vapors which could accidentally ignite. Do not allow disconnected fuel hoses to leak fuel.

**NOTICE** Do not use portable fuel tanks for outboards larger than 115 HP. Inadequate fuel flow to high horsepower outboards can result in serious powerhead damage.

## Fuel Flow Requirements

	15 – 30 HP	40 – 90 HP	115 – 300 HP
Fuel tank pickup tube	1/4 in. (6.4 mm) min. ID	5/16 in. (7.9 mm) min. ID	3/8 in. (9.5 mm) min. ID
Fuel fittings	5/32 in. (4.1 mm) min. ID	1/4 in. (6.4 mm) min. ID	9/32 in. (7.1 mm) min. ID
Fuel supply hoses	1/4 in. (6.4 mm) min. ID	3/8 in. (9.5 mm) min. ID	3/8 in. (9.5 mm) min. ID
<b>ALL MODELS</b>			
Fuel tank pickup screen	100 mesh, 304 grade stainless steel wire, 0.0045 in. wire diameter, 1 in. (25 mm) long		
Antisiphon valve	2.5 in. (63.5 mm) Hg maximum pressure drop at 20 gph (76 l/hr) flow		
Remote fuel filter	0.4 in. Hg maximum pressure drop at 20 gph (76 l/hr) flow, 150 in. <sup>2</sup> (1290 cm <sup>2</sup> ) of filter area		
Maximum fuel pump lift height	Fuel pump should not be located more than 30 in. (76.2 cm) above bottom of fuel tank		

## Fuel Requirements

### WARNING

**Gasoline is extremely flammable and highly explosive under certain conditions. Improper handling of fuel could result in property damage, serious injury or death.**

**Always turn off the outboard before fueling.**

**Never permit anyone other than an adult to refill the fuel tank.**

**Do not fill the fuel tank all the way to the top or fuel may overflow when it expands due to heating by the sun.**

**Remove portable fuel tanks from the boat before fueling.**

**Always wipe off any fuel spillage.**

**Do not smoke, allow open flames or sparks, or use electrical devices such as cellular phones in the vicinity of a fuel leak or while fueling.**

### Minimum Octane

*Evinrude/Johnson* outboards are certified to operate on unleaded automotive gasoline with an octane rating equal to or higher than:

- 87 (R+M)/2 AKI, or
- 90 RON

Use unleaded gasoline that contains methyl tertiary butyl ether (MTBE) **ONLY** if the MTBE content does not exceed 15% by volume.

Use alcohol-extended fuels **ONLY** if the alcohol content does not exceed:

- 10% ethanol by volume
- 5% methanol with 5% cosolvents by volume

When using alcohol-extended fuels, be aware of the following:

- The boat's fuel system may have different requirements regarding the use of alcohol fuels. Refer to the boat's owner guide.
- Alcohol attracts and holds moisture that can cause corrosion of metallic parts in the fuel system.
- Alcohol blended fuel can cause engine performance problems.
- All parts of the fuel system should be inspected frequently and replaced if signs of deterioration or fuel leakage are found. Inspect at least annually.

**IMPORTANT:** Always use fresh gasoline. Gasoline will oxidize, resulting in loss of octane and volatile compounds, as well as the production of gum and varnish deposits which can damage the outboard.

### Additives

**IMPORTANT:** The only fuel additives approved for use in *Evinrude* outboards are 2+4<sup>®</sup> fuel conditioner and *Evinrude/Johnson* Fuel System Cleaner. **Use of other fuel additives can result in poor performance or engine damage.**

***Evinrude/Johnson* 2+4 Fuel Conditioner** will help prevent gum and varnish deposits from forming in fuel system components and will remove moisture from the fuel system. It can be used continuously and should be used during any period when the outboard is not being operated on a regular basis. Its use will reduce spark plug fouling, fuel system icing, and fuel system component deterioration.

***Evinrude/Johnson* Fuel System Cleaner** will help keep fuel injectors in optimal operating condition.

## FUEL SYSTEM COMPONENTS

# COMPONENTS

The fuel system includes the following components:

- Fuel Lift Pump
- Fuel Filter
- Vapor Separator
- Fuel Circulation Pump
- Fuel Supply Manifolds
- Fuel Injectors
- Fuel Return Manifolds

## Fuel Lift Pump

The fuel lift pump is a mechanical, pressure-pulse pump. The diaphragm of the pump is driven by a pulse hose that connects to the cylinder/crankcase assembly.

Fuel lift pump pulse hose location:

- **2-Cylinder Models:** Number 2 cylinder
- **3-Cylinder Models:** Number 3 cylinder

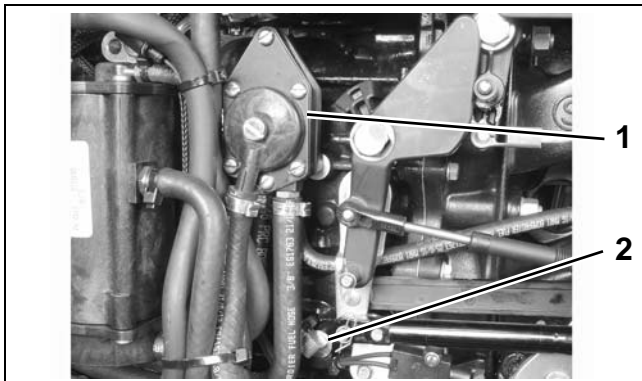

**2-Cylinder models**

006558

1. Fuel lift pump
2. Pulse hose fitting

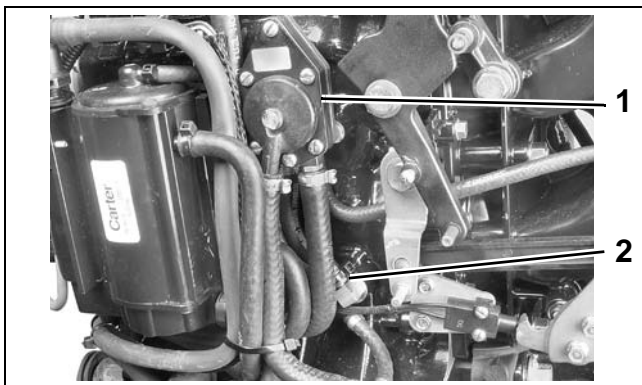

**3-Cylinder models**

002314

1. Fuel lift pump
2. Pulse hose fitting

Vacuum from the fuel lift pump pulls fuel from the fuel tank. Once fuel reaches the pump, internal pump pressure forces the fuel from the pump through the fuel filter and into the vapor separator.

## Fuel Filter

The fuel filter protects the vapor separator and the high-pressure components of the fuel system from contaminants. Refer to **INSPECTION AND MAINTENANCE SCHEDULE** on p. 16 for service frequency.

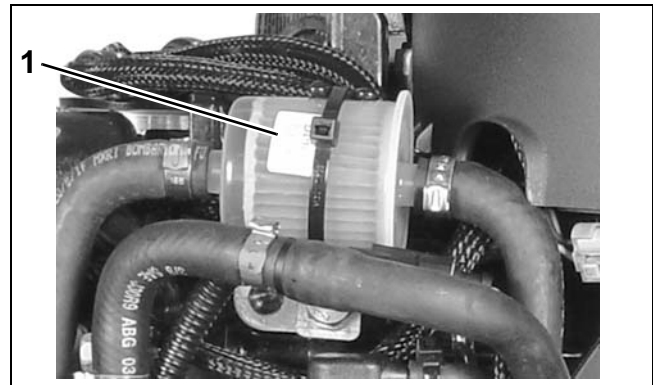

1. Filter

002145

## Vapor Separator

The vapor separator:

- Serves as a water-cooled fuel reservoir to accumulate incoming fuel from the fuel lift pump and from the fuel return manifold.
- Contains a float controlling the venting of fuel vapors.
- Contains a fuel pressure regulator for the high pressure fuel system.



The vapor separator is serviced as an assembly and includes the fuel circulation pump.



**Vapor Separator Assembly**  
1. Circulation pump

006555

### Fuel Reservoir

The vapor separator accumulates fuel in an internal fuel reservoir and supplies fuel to the electric circulation pump. It is water-cooled to enhance vapor separating capabilities.

### Cooling

Water is used to cool the fuel as it flows through the vapor separator. The cooling passage of the separator self-drains when the outboard is stored vertically. Refer to **HOSE ROUTING AND WATER FLOW DIAGRAMS** on p. 174.

### Venting

The fuel vapor vent regulates fuel vapor pressure in the reservoir.



1. Vent

005007

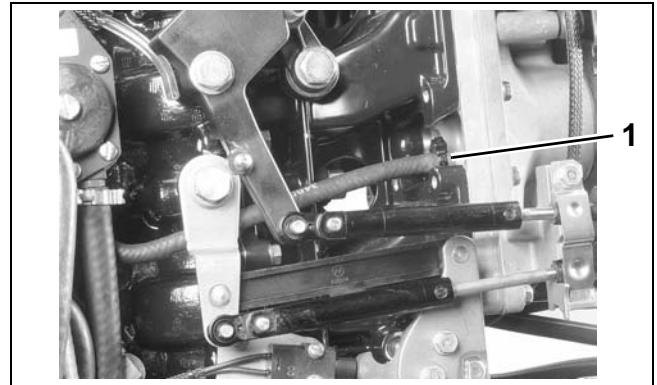

1. Vent hose connection to intake

002180

The vapor separator vent is opened and closed by a float valve. The float valve moves with the fuel level in the fuel chamber. Hot fuel causes an increase in vapor pressure. This results in a lower fuel level in the vapor separator. The float valve drops and the vent opens. This allows fuel vapor to flow to the intake manifold through the vent hose.

As the vapor pressure in the vapor separator decreases, the fuel level begins to increase. An increase in the fuel level raises the float valve and the vent closes.

### Pressure Regulator

The fuel pressure regulator helps maintain consistent fuel pressure in the fuel system.

Fuel returning from the injectors enters the fuel chamber of the vapor separator through a pressure regulator. The pressure regulator maintains approximately 20 to 30 psi (138 to 207 kPa) of fuel pressure in the high pressure side of the fuel system.

## FUEL SYSTEM COMPONENTS

### Fuel Circulation Pump

The fuel circulation pump is an electric high pressure fuel pump.

### Fuel Supply

The pump is mounted to the vapor separator and draws fuel from the fuel chamber. It pumps pressurized fuel through a fuel supply manifold connected to the fuel injectors.

### Electrical Circuit

The circulation pump is controlled by the *EMM* and operates on the 55 V circuit. The outboard must be cranking or running (CPS input to *EMM*) for the circulation pump to be activated. The *EMM* controls pump operation by rapidly connecting and disconnecting the pump's internal coil to ground.

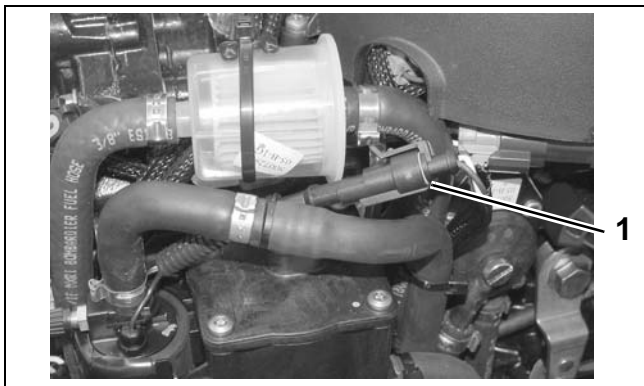

1. Fuel pump electrical connector

006557

### Fuel Manifolds

The fuel supply and return manifolds route fuel through the high pressure side of the fuel system.

### Fuel Supply Manifold

The fuel supply manifold supplies pressurized fuel to the inlet port of each fuel injector.

### Fuel Return Manifold

The fuel return manifold provides a route for fuel passing through the fuel injectors to flow back to the fuel chamber of the vapor separator.

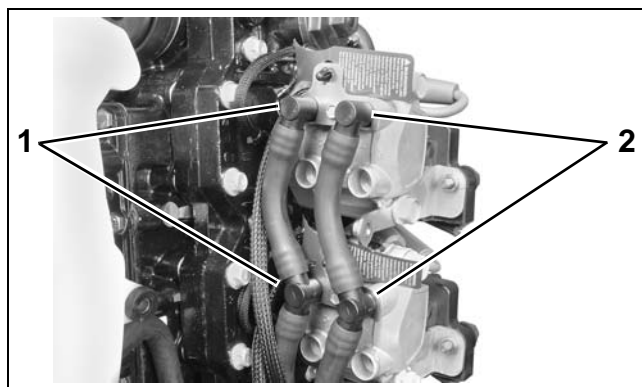

1. Fuel supply
2. Fuel return

006560

### Fuel Injectors

Fuel injectors are fuel metering, electric solenoids (55 V) bolted directly to the cylinder head. The *EMM* controls the activation of each injector by rapidly connecting and disconnecting the injector's internal coil to ground.

### Fuel Flow Compensation

The flow rate of each injector is measured as part of the manufacturing process. This information is recorded and assigned to the injector by serial number.

The *EMM* is programmed to compensate for variations in fuel flow. Each injector and its location on the outboard is identified by the *EMM*. DO NOT install an injector without updating the compensation software.

Each service injector includes its fuel flow information on a 3.5 in. floppy disk. This software allows the *EMM* to be reprogrammed for this injector's unique fuel flow characteristics.

**NOTICE** Fuel injectors **MUST NOT** be moved from one cylinder to another. *EMM* programming is associated with the cylinder location of each injector. Installing an injector on the wrong cylinder can result in powerhead failure.

### **Injector Fuel Supply**

Fuel is supplied to the injectors by the fuel circulation pump and the fuel supply manifold.

Each injector has internal fuel passages. These passages are designed to:

- Provide fuel to the injector's injection chamber
- Route fuel through the injector housing to cool the injector coil and armature

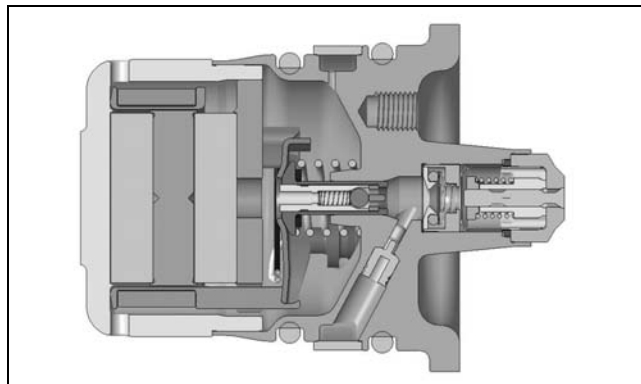

006619



## FUEL SYSTEM TESTS

### ⚠ WARNING

Use caution when working on any pressurized fuel system. Wear safety glasses and work in a well ventilated area. Extinguish all smoking materials and make certain no open flames or ignition sources exist. Before starting any fuel system service, carefully relieve fuel system pressure. Failure to properly relieve fuel system pressure can result in spraying fuel and/or excessive fuel spillage during servicing. Fuel is flammable and can be explosive under certain conditions.

### Fuel System Pressure Test

Relieve fuel system pressure. Refer to **Relieving Fuel System Pressure** on p. 142.

### ⚠ WARNING

Protect against hazardous fuel spray. Before starting any fuel system service, carefully relieve fuel system pressure.

After relieving fuel system pressure, install a 0 to 60 psi (0 to 415 kPa) Fuel Pressure Gauge, P/N 5007100 or equivalent, to the upper fuel pressure test fitting.

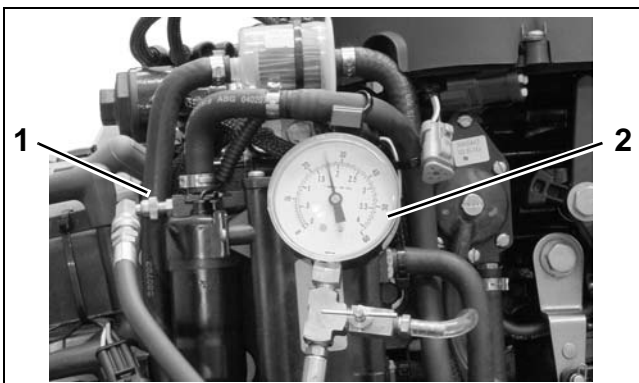

1. Test fitting  
2. Fuel pressure gauge

006655

START outboard and check pressure. System pressure should be 20 to 35 psi (138 to 241 kPa).

Shut OFF outboard. Monitor pressure gauge. Pressure should not drop below 15 psi (103 kPa).

**IMPORTANT:** If outboard does not run, prime fuel system and crank outboard; check circulation pump operation; check fuel system pressure.

#### Results:

Normal pressure:

- Observe pressure reading after outboard is shut OFF
- Refer to **Lift Pump Pressure Test** on p. 139

Pressure drops after outboard is shut OFF:

- Check for leaking fuel injector.
- Check for leaking pressure regulator.
- Check for external fuel system leak.

High pressure:

- Check for restricted filter or fuel return fitting of vapor separator, damaged pressure regulator in vapor separator, or restricted fuel return manifold.

Low pressure:

- Check fuel supply to fuel lift pump. Refer to **Lift Pump Vacuum Test** on p. 140. Higher vacuum readings indicate restrictions in the fuel supply. Repair or replace as needed.
- Restricted fuel filter/water separator assembly.
- Lift pump not supplying enough fuel to vapor separator. Refer to **Lift Pump Pressure Test** on p. 139.
- If the above tests are good and vapor separator remains full of fuel, check for damaged circulation pump. Replace vapor separator assembly.

No pressure:

- Check electrical circuit and ground connections for circulation pump.
- If voltage is present and pump does not run, repair connection or replace vapor separator assembly.

Relieve fuel system pressure before removing fuel pressure gauge. Refer to **Relieving Fuel System Pressure** on p. 142.

## FUEL SYSTEM

### FUEL SYSTEM TESTS

#### Pressure Regulator Test

Refer to **Vapor Separator Service** on p. 144 to remove vapor separator.

Make sure filter is not clogged. Clean or replace as needed.

Apply oil to valve and connect pressure pump and hose to the fuel return fitting of vapor separator.

Apply pressure to check regulator operation. The pressure should open check valve at approximately 15 psi (103 kPa).

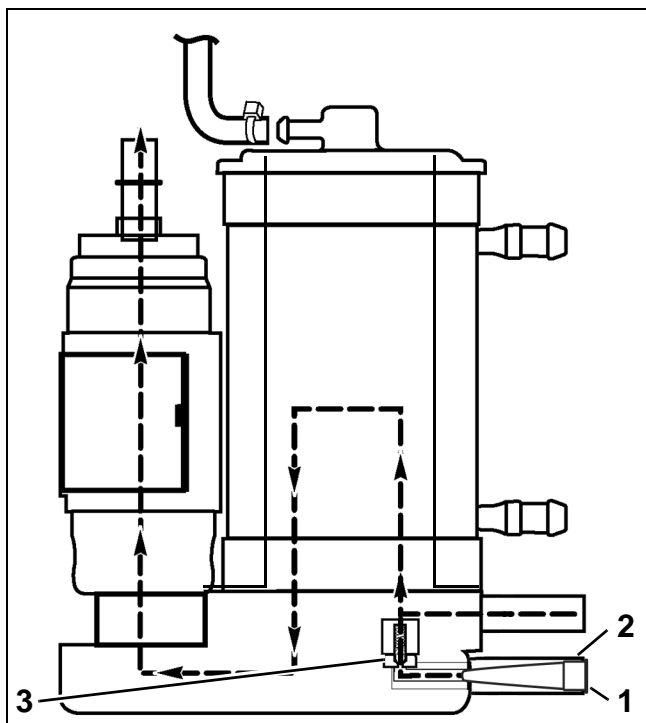

1. Filter
2. Fuel return fitting
3. Pressure regulator

000249r

#### Vapor Separator Vent Check

Monitor the vapor separator vent hose. No fuel or a trace of fuel is acceptable. Excessive fuel discharge indicates a vapor separator vent malfunction. Monitor vent for presence of fuel during testing. Temporarily install clear tubing for monitoring. Replace vapor separator if the venting of fuel is continuous.

#### Fuel Injector Pressure Test

This test requires Injector Test Fitting kit, P/N 5005844.

Disconnect the battery cables at the battery.

Loosen oil tank assembly to provide access to fuel manifolds. Refer to **Oil Tank Assembly** on p. 169.

Relieve fuel system pressure. Refer to **Relieving Fuel System Pressure** on p. 142.

#### ⚠ WARNING

**Protect against hazardous fuel spray. Before starting any fuel system service, carefully relieve fuel system pressure.**

**IMPORTANT:** Perform test with injector mounted to cylinder head and fittings installed with manifold retainer.

Use cap and tie strap to seal off outlet fitting. Connect a 0 to 30 psi (0 to 207 kPa) pressure tester to the inlet fitting. Pressurize the injector to 30 psi (207 kPa). Pressure must hold for at least five minutes.

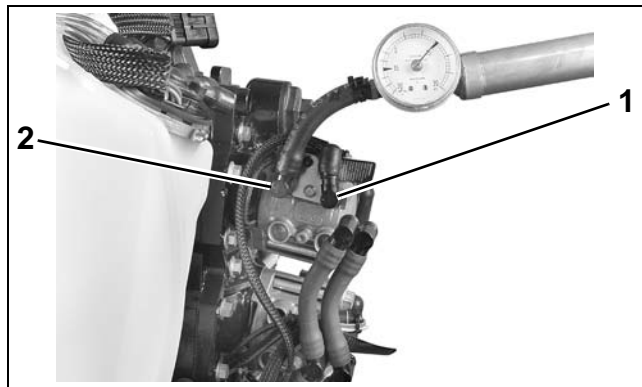

1. Outlet fitting
2. Inlet fitting

002379

Refer to **FUEL DELIVERY TESTS** on p. 84 for additional test procedures.

## Fuel Injector Resistance Test

Disconnect the battery cables at the battery.

Use a digital multimeter to measure the injector coil resistance.

<b>Fuel Injector Coil Resistance</b>
--------------------------------------

2 to 3 $\Omega$ @ 72°F (22°C)
-------------------------------



006620

Use a digital multimeter with appropriate adapter leads to measure resistance of the complete injector circuit, including injector and associated wiring.

Measure resistance between pin 1 (white/red) of injector connector (connected) and the appropriate pin location of *EMM* J1-B connector (disconnected). Refer to engine wiring diagram for specific *EMM* J1-B connector pin location for the injector circuit being tested (blue, purple or green).



006621

Resistance should be the same as, or slightly higher than, the injector alone.

## Circulation Pump Resistance Test

Disconnect the battery cables at the battery.

Use a digital multimeter with appropriate adapter leads to measure the fuel pump circuit and coil resistance.

<b>Fuel Pump Resistance</b>
-----------------------------

3 $\Omega$ @ 77°F (25°C)
--------------------------



006633

## Lift Pump Pressure Test

Install a 0 to 15 psi (0 to 103 kPa) Fuel Pressure Gauge, P/N 5006397 or equivalent, to the lower fuel pressure test fitting.

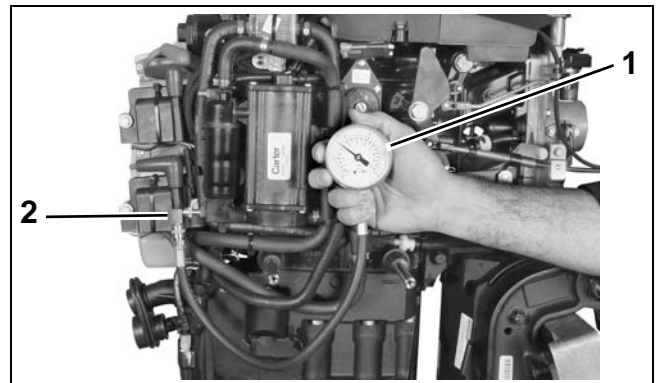

1. Fuel pressure gauge
2. Test fitting

006634

Prime the fuel system and check for leaks. START outboard and run at idle speed. Hold gauge level with inlet fitting and monitor gauge for pressure reading.

Pressure should stabilize at a reading greater than 3 psi (27 kPa).

---

## FUEL SYSTEM

### FUEL SYSTEM TESTS

---

#### Results:

Normal pressure:

- Perform the **Lift Pump Vacuum Test** on p. 140. Make sure no air leaks or restrictions exist in the fuel supply hose or boat fuel system.

Low pressure:

- Check pulse hoses and fittings for restrictions.
- Perform the **Lift Pump Vacuum Test** on p. 140. Make sure no air leaks or restrictions exist in the fuel supply hose or boat fuel system.
- Check fuel flow through fuel lift pump. Use fuel primer bulb to force fuel through pump.

No pressure:

- Check pulse hoses and fittings restrictions.
- Check fuel flow through fuel lift pump. Use fuel primer or primer bulb to force fuel through pump.
- Momentarily prime or squeeze primer bulb to check gauge operation.
- Check pulse hose and fittings for restrictions.

### Lift Pump Vacuum Test

Confirm fuel supply to the fuel lift pump.

Temporarily install a vacuum gauge, T-fitting, and 8 in. (20.3 cm) of clear vinyl hose between the fuel supply hose and fuel lift pump (inlet). Secure connections with tie straps to prevent fuel or air leaks.

**NOTICE** Do not use fuel primer bulb, manual fuel primer, or electric fuel pump primer to restart outboard. A positive pressure in the fuel supply could damage some vacuum gauges.

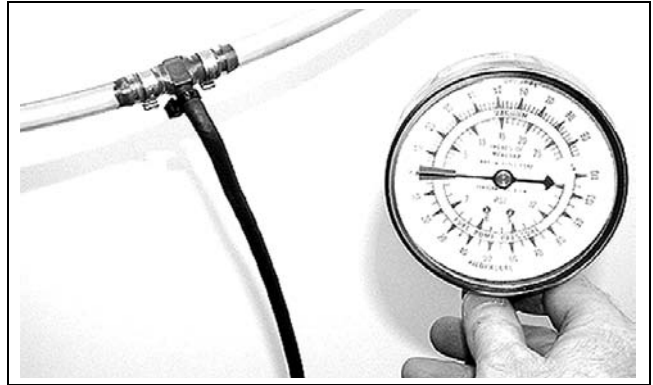

000243

START outboard and run at FULL THROTTLE for at least two minutes. Monitor clear vinyl hose for the presence of air. Air bubbles indicate a faulty hose, connection, or fuel tank pick-up. Repair, if necessary, before proceeding.

There should be no air or vapor bubbles visible in the clear hose. The maximum inlet fuel vacuum should not exceed 4 in. Hg. (13.5 kPa) at the inlet to the fuel lift pump under any operating conditions (IDLE to WOT).

A higher vacuum indicates an excessive restriction in the fuel supply. Repair as needed. Refer to **FUEL SYSTEM REQUIREMENTS** on p. 130 for fuel supply component requirements.



## Lift Pump Diaphragm Test

Perform this test only if a damaged pump is suspected. This test does not confirm the performance of internal fuel pump check valves.

Remove the pulse hose from the crankcase fitting.

Apply 15 psi (103 kPa) to the pulse hose of the pump. Replace lift pump if pump fails to hold pressure.

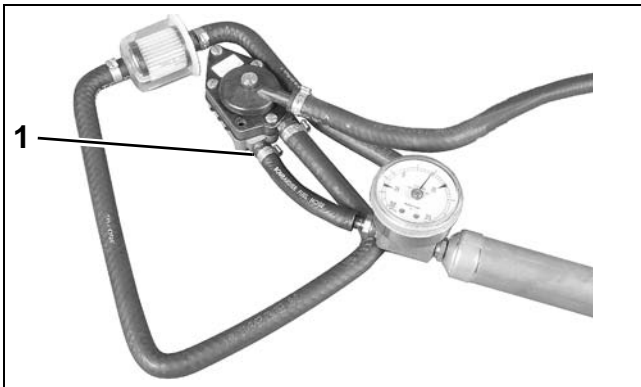

1. Pulse fitting

002334a

## Anti-Siphon Valve Test

Remove anti-siphon valve from fuel tank. Install adapter fittings and a 36 in. (91.4 cm) length of clear hose to the inlet side (tank end) of valve.

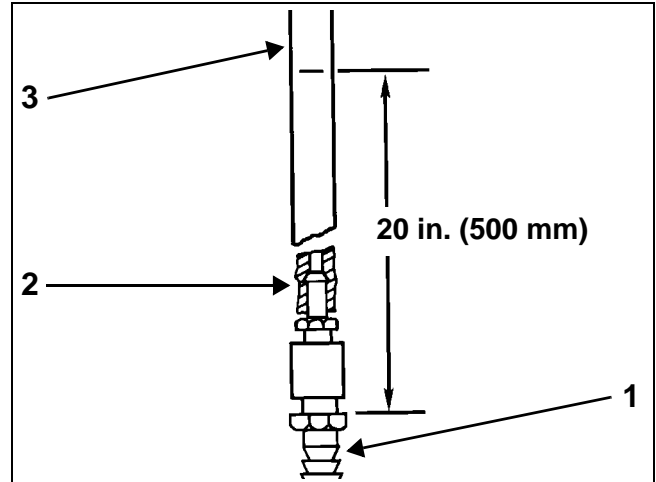

1. Anti-siphon valve
2. Adapter fitting
3. Clear hose

DR2277

Fill clear hose with water to a height of 20 in. (500 mm). Water must NOT flow through valve. An occasional drip is acceptable. Replace valve if water drips continuously.

Increase height of water to 25 in. (630 mm). Water should flow through valve as water level reaches 25 in. (630 mm). Replace the anti-siphon valve if test results are different.

## FUEL COMPONENT SERVICING

### **⚠ WARNING**

Gasoline is extremely flammable and highly explosive under certain conditions. Use caution when working on any part of the fuel system.

Protect against hazardous fuel spray. Before starting any fuel system service, carefully relieve fuel system pressure. Refer to Relieving Fuel System Pressure.

Always disconnect the battery cables at the battery before servicing the fuel system unless instructed to do otherwise.

Always work in a well ventilated area and wipe off any fuel spillage.

**DO NOT** smoke and make certain no open flames or ignition sources exist.

After servicing the fuel system check for leaks. Failure to check for fuel leakage could allow a leak to go undetected, resulting in fire or explosion.

### Relieving Fuel System Pressure

**IMPORTANT:** Minimize fuel system pressure before disassembly. Temporarily restrict the fuel supply hose from fuel tank with hose pincer. Remove propeller and disconnect circulation fuel pump electrical connector. If outboard runs, start and run at IDLE for 5 seconds and STOP outboard. If outboard does NOT run, crank for 10 seconds.

Disconnect the battery cables at the battery.

Wrap a shop towel completely around the pressure test valve while connecting fitting from Fuel Pressure Gauge, P/N 5007100, to top test fitting of fuel pump/vapor separator assembly.



1. Shop towel

005011

Insert venting hose of gauge into a suitable container.

Slowly open gauge's venting valve.

Clean up any spilled fuel with shop towels.

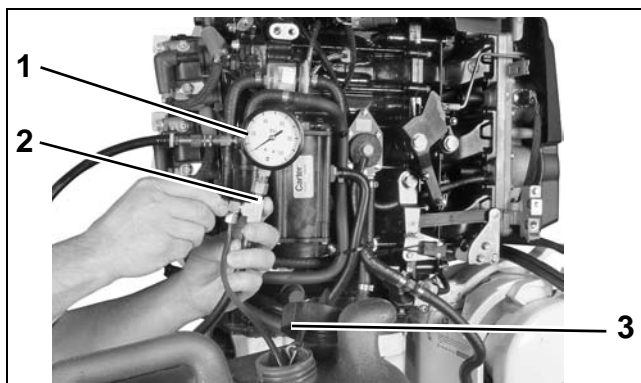

1. Test fitting  
2. Venting valve  
3. Venting hose

005012

## Fuel Filter Service

### Removal

Disconnect the battery cables at the battery.

Remove filter carefully to prevent spilling contents.

Inspect contents for any presence of water. If water is present, identify the source and correct the problem. Take additional fuel samples and drain fuel tank(s) if necessary.

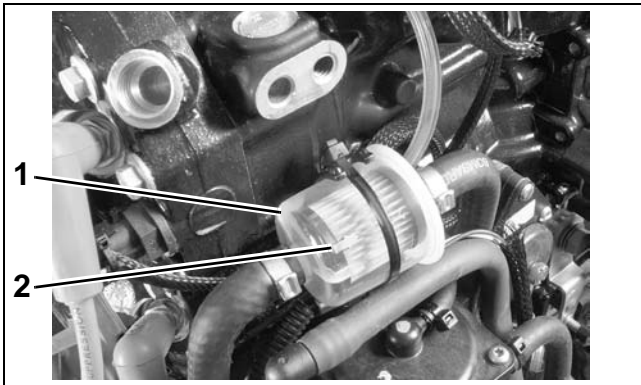

1. Fuel filter
2. Arrow

002192

### Installation

Install filter in fuel supply hoses. Note arrow indicating direction of fuel flow on filter. Secure filter with appropriate clamps.

Squeeze primer bulb to prime fuel system. Hold pressure on bulb and check for fuel leaks.

Connect battery cables.

Run outboard and check for fuel leaks.

## Fuel Lift Pump Service

The fuel lift pump is serviceable as a complete assembly or can be repaired with a fuel pump repair kit. Refer to parts catalog for service parts.

### Removal

Disconnect the battery cables at the battery.

Disconnect the fuel hoses from the fuel pump housing.

Disconnect the fuel lift pump pulse hose at the crankcase fitting.

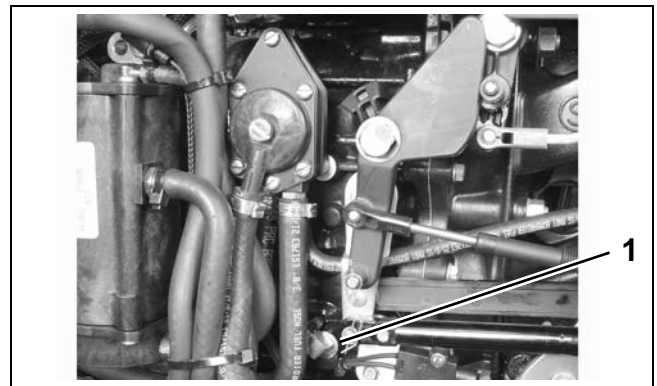

1. Crankcase fitting

006558

Loosen the fuel lift pump mounting screws. Remove the fuel lift pump as an assembly.

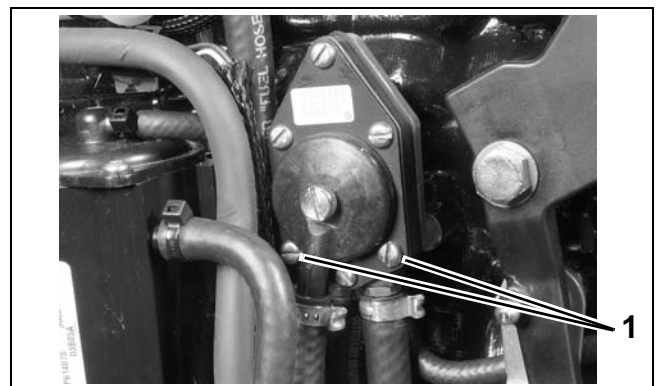

1. Screws

002194

Fuel pump repair kit, P/N 438616, is available for internal service of fuel pump. Refer to instructions included with kit.

## FUEL SYSTEM

### FUEL COMPONENT SERVICING

#### Installation

Place fuel pump in position on crankcase. Apply *Nut Lock* to mounting screws. Tighten screws to a torque of 24 to 36 in. lbs. (2.8 to 4.0 N·m).

Connect the fuel lift pump pulse hose to the crankcase. Secure with tie strap.

Connect the fuel hoses to the fuel filter. Secure with *Oetiker* clamps.

Squeeze primer bulb to prime fuel system. Hold pressure on bulb and check for fuel leaks.

Connect battery cables.

Run outboard and check for fuel leaks.

#### Vapor Separator Service

##### Removal

Disconnect the battery cables at the battery.

Relieve fuel system pressure. Refer to **Relieving Fuel System Pressure** on p. 142.

Disconnect circulation pump electrical connector.

Remove clamp and fuel supply manifold from top of circulation pump. Remove clamp and vapor vent hose from separator cover.

Remove clamps and vapor separator cooling water hoses.

Remove clamps and fuel return manifold and fuel supply hose from bottom of vapor separator.

Remove the vapor separator housing retainer clip.

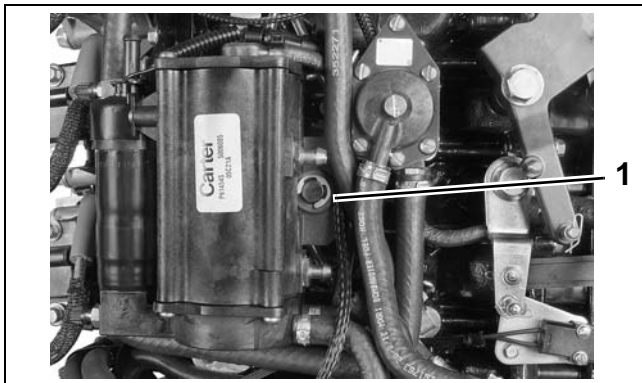

1. Retainer clip

005013

Remove vapor separator/fuel pump from the mounting stud and slide vapor separator housing from the grooves of the isolator mounts.

##### Installation

Slide the vapor separator bracket notches into grooves of the isolator mounts. Install forward isolator of vapor separator on mounting stud and secure with retainer clip.

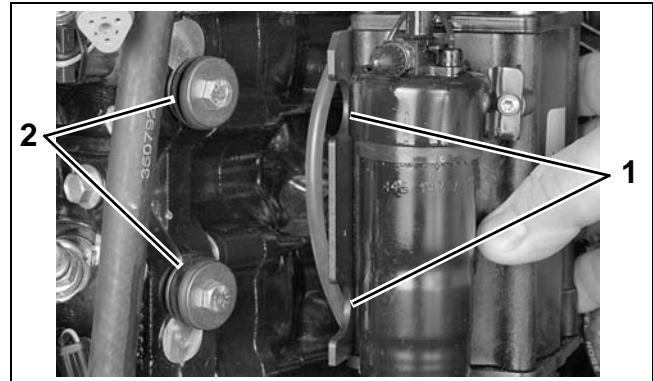

1. Notches  
2. Isolator mounts

007859

Install all hoses and manifolds in original locations and secure with appropriate clamps. Route hoses and secure with tie straps as shown.

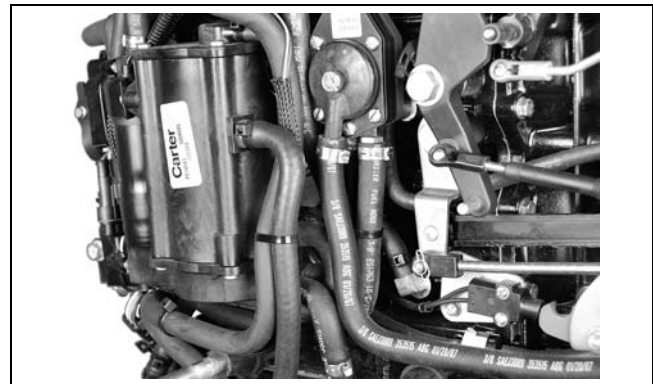

007860

Squeeze primer bulb to prime fuel system. Hold pressure on bulb and observe for fuel leaks.

Connect battery cables.

Run outboard and check for fuel leaks.

## Fuel Manifold Service

### Removal

Disconnect the battery cables at the battery.

Relieve fuel system pressure. Refer to **Relieving Fuel System Pressure** on p. 142.

Remove oil tank assembly. Refer to **Oil Tank Assembly** on p. 169.

Remove clamps and disconnect the fuel manifolds as follows:

- Fuel supply manifold to circulation pump.
- Fuel return manifold to vapor separator.



1. Fuel supply manifold  
2. Fuel return manifold

006555

Remove fuel manifold retainer screws and remove retainers from fuel injectors.

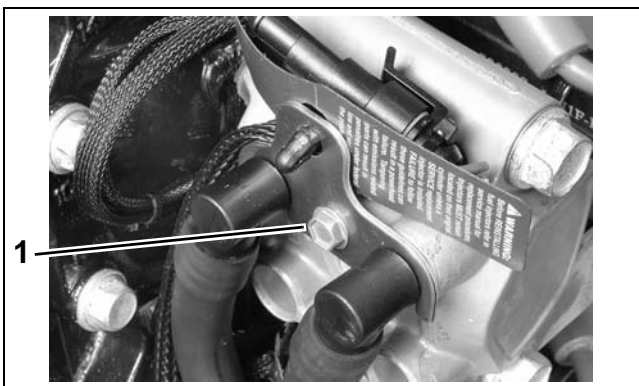

1. Screw

006559

Disconnect fuel manifold fittings from fuel injector ports, then remove the manifold assemblies.

### Installation

Check condition of sealing O-rings on fuel manifold fittings. Lubricate O-rings with outboard lubricant and insert fuel manifold fittings into injector. Both fittings must be fully seated into the injector fuel ports.

Install retainer in the outer groove of the manifold fittings. Install and tighten screw to a torque of 24 to 36 in. lbs. (2.7 to 4 N·m).

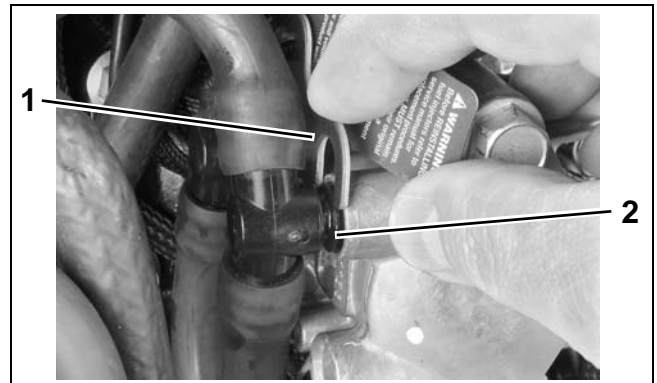

1. Retainer  
2. Manifold fitting groove

005342

Install the fuel manifolds to the fuel pump assembly and secure with clamps:

- Fuel supply manifold to circulation pump.
- Fuel return manifold to vapor separator.

Install oil tank assembly. Refer to **Oil Tank Assembly** on p. 169.

# FUEL SYSTEM

## FUEL COMPONENT SERVICING

### Fuel Injector Service

Mark fuel injectors to show cylinder locations.

**NOTICE** Fuel injectors must be installed in the correct cylinder locations. Use *Evinrude Diagnostics* Software to make sure that *EMM* programming matches injector positioning. The *Injector Coefficients* screen displays injector serial numbers for each cylinder.

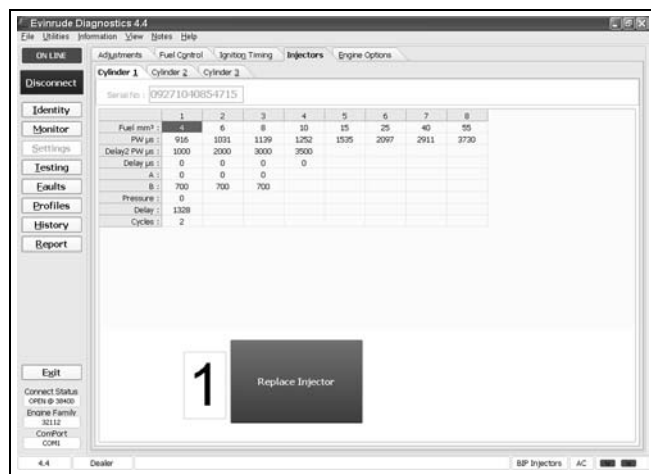

Injector Coefficients Screen

008079

Use caution when handling fuel injectors. Prevent dirt and debris from entering fuel inlet and outlet ports of injectors or fuel manifolds. Cover the injector nozzle port in cylinder head to prevent contamination of combustion chamber.

### Removal

Disconnect the battery cables at the battery.

Relieve fuel system pressure. Refer to **Relieving Fuel System Pressure** on p. 142.

Remove fuel manifolds. Refer to **Fuel Manifold Service** on p. 145.

Remove the ignition coil assemblies.

Disconnect the fuel injector electrical connector.

Remove injector screws.

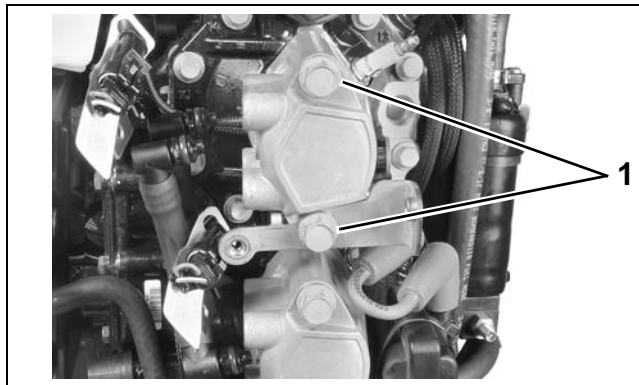

1. Injector screws

006561

Remove fuel injector and insulator.

### Crush Ring Replacement

**NOTICE** Injector crush rings must be replaced if injector is installed in a different head or cylinder location.

Use Slide Hammer assembly, P/N 391008, with Slide Hammer Adaptor kit, P/N 390898, to remove injector from mounting cup.

Thread adaptor and stud into face of injector. Hold mounting cup securely. Use slide hammer to separate injector from mount housing.



002345

Remove adaptor from injector. Remove crush ring and O-rings from injector. Inspect and clean injec-

tor filter. Install new crush ring and O-rings. Lubricate O-rings with *STP<sup>+</sup> Oil Treatment*.



1. Adaptor 002196

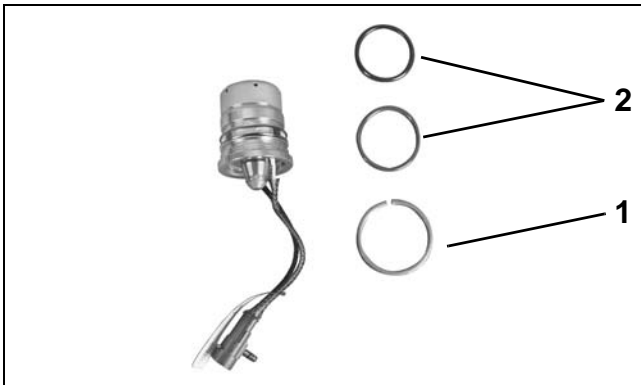

1. Crush ring 002317  
2. O-rings

Install injector into mount housing. Press on injector face until injector seats in mount housing.

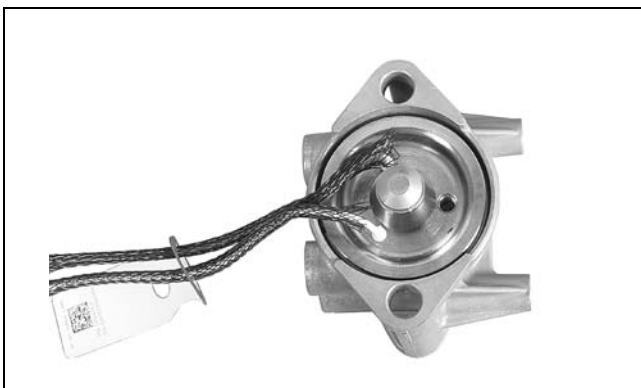

002318

## Installation

**NOTICE** All injectors must be installed in the correct cylinder by serial number. Improper injector installation can result in powerhead failure.

Installation of a replacement injector requires that coefficient data for the new injector is uploaded to the *EMM*.

Coefficient data for some replacement injectors is supplied on a computer disk shipped with the injector. If a disk is not included with the injector, coefficient data can be downloaded from the *Evinrude/Johnson* dealer website. Refer to the instructions provided with the injector kit.

### Upload Coefficient Files to *EMM*

Use the *Evinrude Diagnostics* software *Settings* screen to upload the coefficient file to the *EMM*.

Select the *Injectors* tab.

Select the cylinder tab for injector being replaced.

Select the *Replace Injector* button.

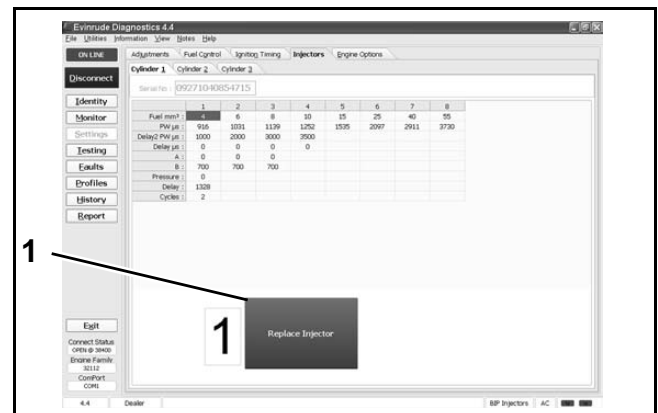

1. "Replace Injector" button

008079

# FUEL SYSTEM

## FUEL COMPONENT SERVICING

Use the drop down menu to navigate to the saved coefficient file location.

The coefficient file name must match the serial number of the injector.

Select the correct file for the injector.

Select the *Replace Injector* button.

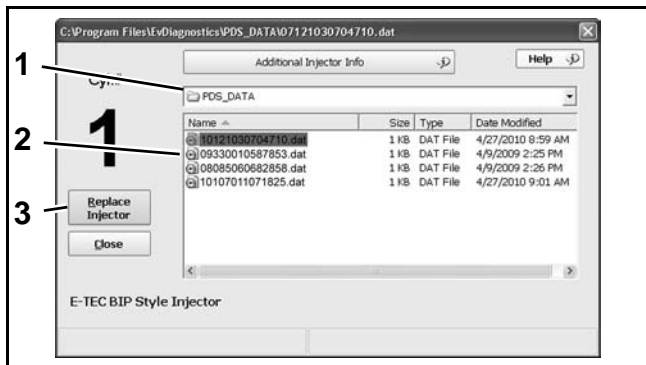

1. Navigation menu 008335
2. Injector coefficient file
3. "Replace Injector" button

After the upload is complete, the program will return to the *Cylinder* tab.

Make sure the serial number displayed on the screen matches the serial number printed on the serial number label of the replacement injector.

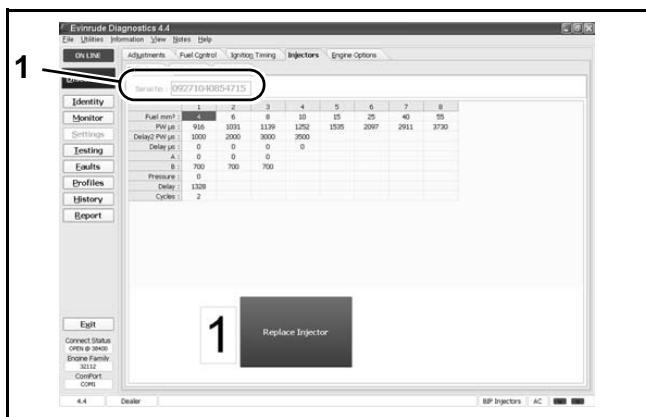

1. Serial number 008079

### Install Injector

The following items and their mating surfaces must be cleaned prior to reassembly:

- Injector
- Cylinder head
- Adapter
- Screws
- Threaded areas.

**⚠ CAUTION**

**All injector components must be clean to ensure correct torque tightening specifications. To prevent fuel leakage, carefully follow these installation instructions.**

Place injector and insulator in the proper cylinder location.

**IMPORTANT:** Be careful not to pinch any wiring or hoses during assembly.

Lubricate mounting screw threads and under the head of the screw with a light coat of *Triple-Guard* grease. Install washers (one per screw) on injector retaining screws. Install screws and washers through mounting flange of injector and into cylinder head.



002316



Tighten screws in stages, starting with the lower screw.

- First torque is 5 ft. lbs. (7 N·m).
- Second torque is 10 ft. lbs. (14 N·m).
- Final torque is 24 to 26 ft. lbs. (33 to 35 N·m).

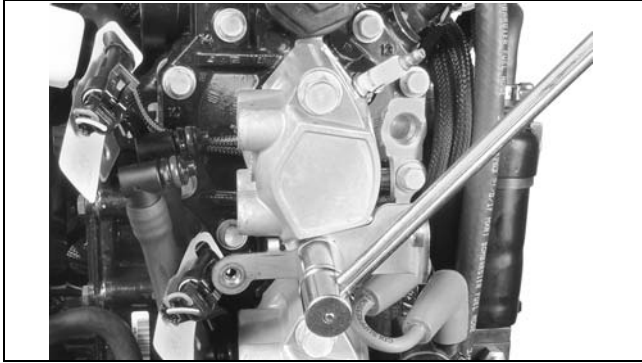

Tighten Screws in Stages

006562

Reconnect fuel injector electrical connectors.

Install the ignition coil assemblies. Tighten coil screws to a torque of 60 to 84 in. lbs (7 to 9.5 N·m).

Install fuel manifolds. Refer to **Fuel Manifold Service** on p. 145.

## Intake Manifold Service

### Removal

Disconnect vapor separator vent hose, main bearing vent hose, air temperature sensor, crankshaft position sensor, and throttle position sensor.

Use Ball Socket Remover Tool, P/N 342226, to remove throttle link arm.

Remove throttle body screws and throttle body assembly.

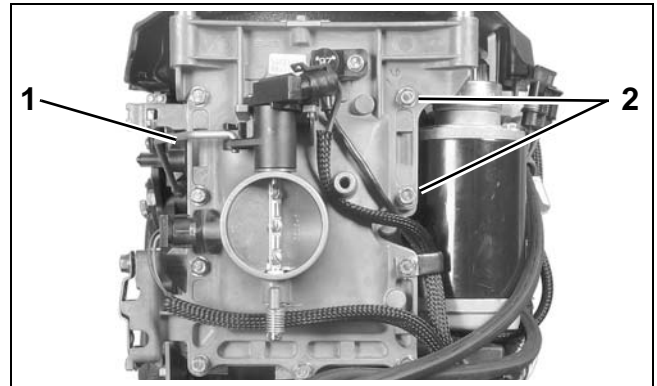

1. Link arm
2. Throttle body screws

002499

7

Remove gasket from throttle body.

Remove screws and reed plate assembly from the crankcase.

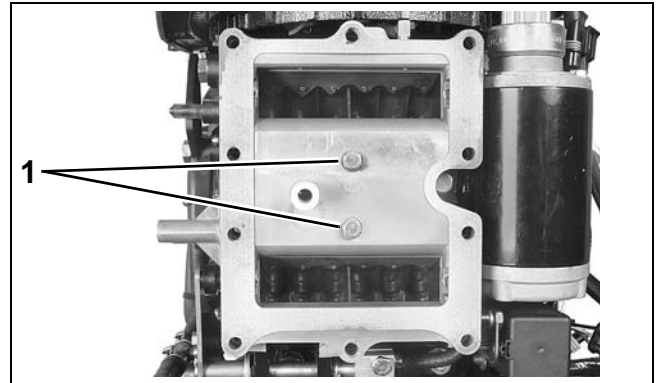

1. Screws

002503

# FUEL SYSTEM

## FUEL COMPONENT SERVICING

### Disassembly

All reed plate assembly and reed valve assemblies must be cleaned prior to reassembly. DO NOT use strong carburetor cleaner or the hot soaking tank method for cleaning.

Remove the reed valve retainer screws and remove the assembly.

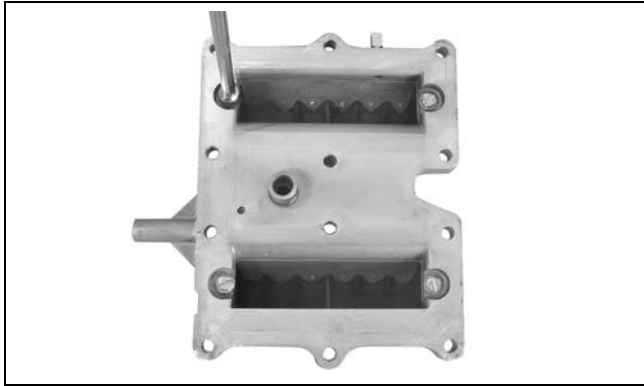

002496

Use caution to prevent damaging reed valve assemblies.

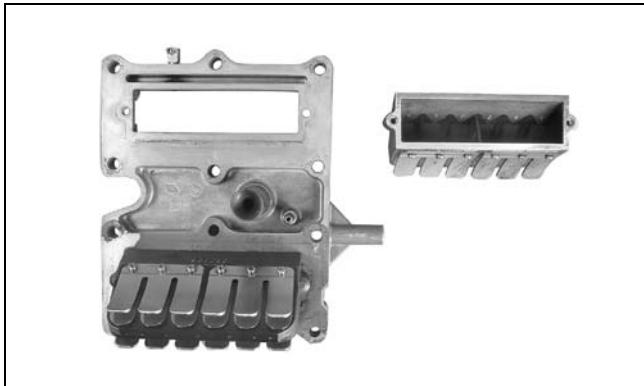

002504

**NOTICE** DO NOT disassemble reed valve assemblies. Damaged reed plates are not serviceable and are replaced as an assembly.

### Inspection

Inspect the leaf plate assemblies for damage or contamination:

- Leaf plates must not be distorted.
- Leaf valve must not be cracked or chipped.
- Leaf plate stops must not be distorted or loose.
- Leaf plate assemblies must be clean.

Inspect the intake manifold. All gasket surfaces must be cleaned, smooth, and free of nicks. Use a machinist's straight-edge and a feeler gauge to check flatness in all directions. Surface must be flat,  $\pm 0.004$  in. (0.10 mm).

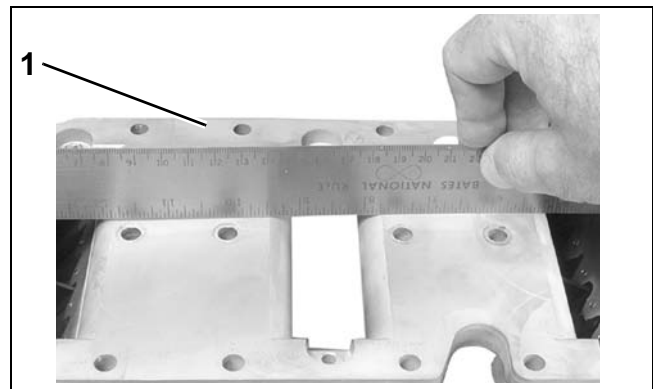

1. Straight-edge

002324

### Assembly

Remove old adhesive from reed valve retaining screws.

Install gasket on reed plate assembly. DO NOT use sealer on the gasket.

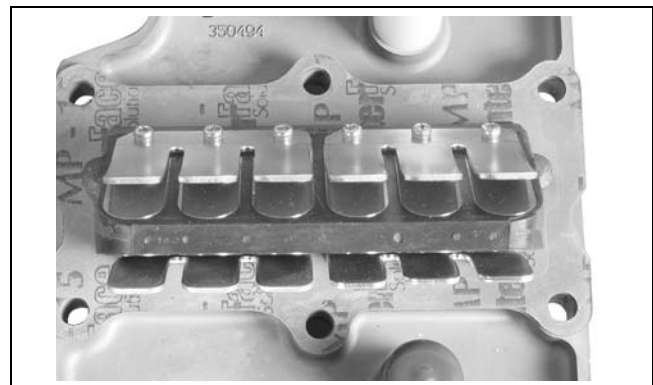

002333

Prime screw threads with *Locquic Primer* and let dry. Apply *Nut Lock* to threads. Position reed valve on reed plate and install screws. Tighten screws to a torque of 25 to 35 in. lbs. (2.8 to 4.0 N·m).

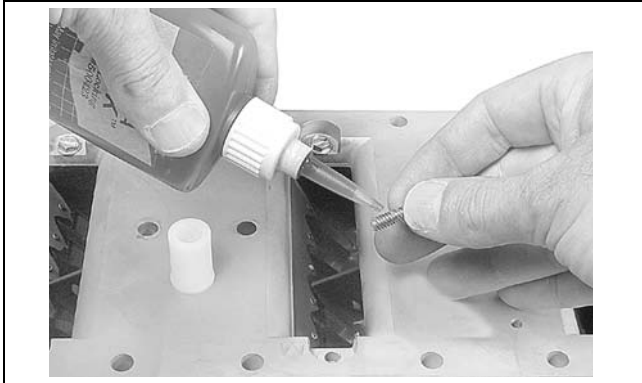

002326

**Installation**

Place reed plate assembly on cylinder/crankcase.

Apply *Nut Lock* to two reed plate screws. Install and tighten screws to a torque of 60 to 120 in. lbs. (7 to 13.5 N·m).

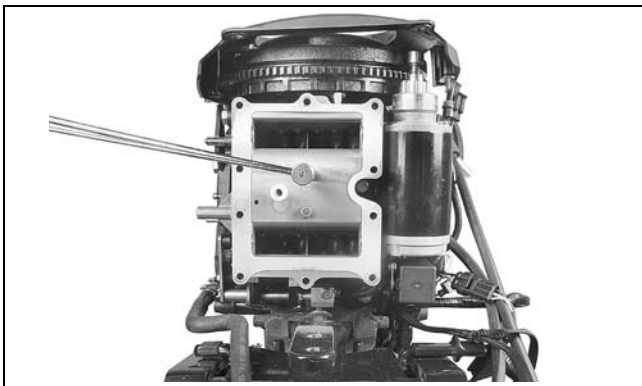

002505

Place gasket on throttle body. Install throttle body on reed plate and install **new** screws.

**IMPORTANT:** If old screws must be re-used, make sure all previous thread locking material is removed and apply *Nut Lock* to threads.

Tighten the center screws first and expand outward. Tighten in stages to a final torque of 60 to 120 in. lbs. (7 to 13.5 N·m).

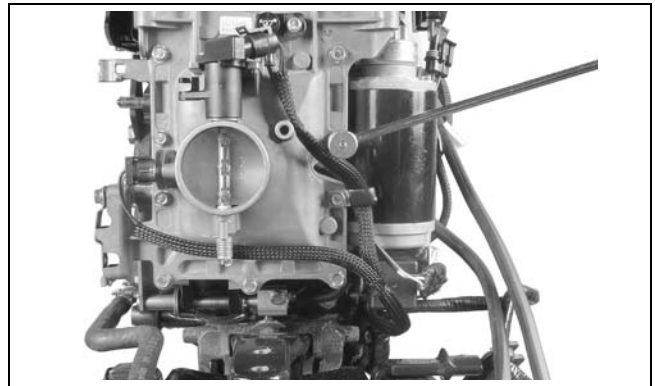

002501

Install vapor separator vent hose and main bearing vent hose. Secure with tie straps.

Install air temperature sensor, crankshaft position sensor, and throttle position sensor electrical connectors.

Connect throttle linkage.

**IMPORTANT:** DO NOT lubricate throttle linkages.

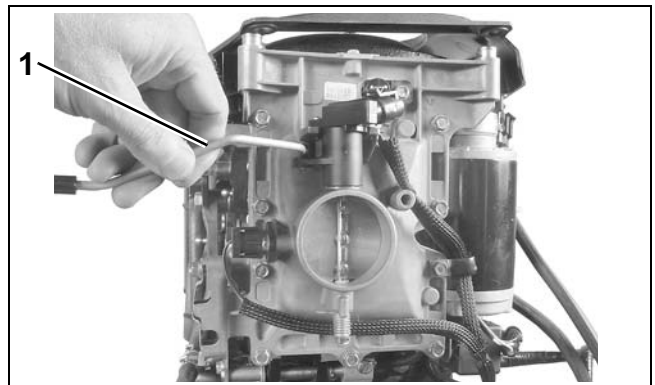

1. Throttle linkage

002500

Refer to **TPS Calibration** on p. 114.



# OILING SYSTEM

## TABLE OF CONTENTS

SERVICE CHART .....	154
OIL SUPPLY DIAGRAMS .....	156
OIL RECIRCULATION DIAGRAMS .....	158
OILING SYSTEM CIRCUIT DIAGRAM .....	159
OIL SYSTEM REQUIREMENTS .....	160
RECOMMENDED LUBRICANTS .....	160
COMPONENTS .....	160
OIL TANK ASSEMBLY .....	160
OIL INJECTION PUMP .....	161
ELECTRICAL CIRCUIT (55 V) .....	161
LOW OIL WARNING .....	162
NO OIL WARNING .....	162
CYLINDER AND CRANKCASE .....	162
OIL RECIRCULATION SYSTEM .....	163
OIL CONTROL SETTINGS .....	164
OIL INJECTION RATE .....	164
BREAK-IN OILING .....	165
OIL SUPPLY PRIMING .....	165
OILING SYSTEM TESTS .....	166
OIL INJECTION PUMP VOLTAGE TESTS .....	166
OIL INJECTION PUMP RESISTANCE TEST .....	167
OIL INJECTION PUMP FUNCTION TEST .....	168
OIL INJECTION FITTINGS FLOW TEST .....	168
LOW OIL SENDING UNIT TEST .....	168
OIL COMPONENT SERVICING .....	169
OIL DISTRIBUTION HOSES .....	169
OIL TANK ASSEMBLY .....	169
OIL INJECTION PUMP .....	171

**SERVICE CHART**

**40 – 65 HP**

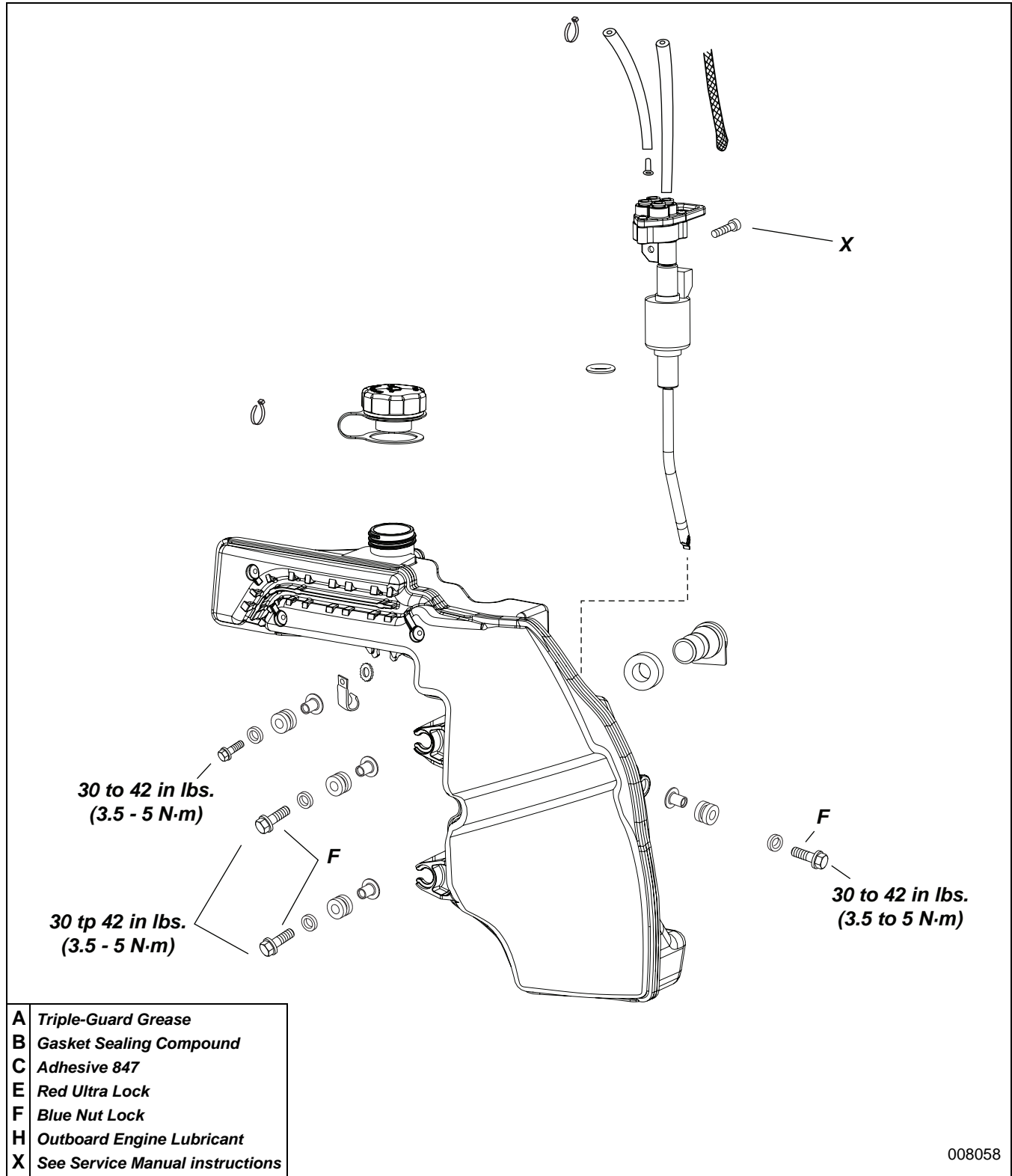

- A** Triple-Guard Grease
- B** Gasket Sealing Compound
- C** Adhesive 847
- E** Red Ultra Lock
- F** Blue Nut Lock
- H** Outboard Engine Lubricant
- X** See Service Manual instructions

008058

75 – 90 HP

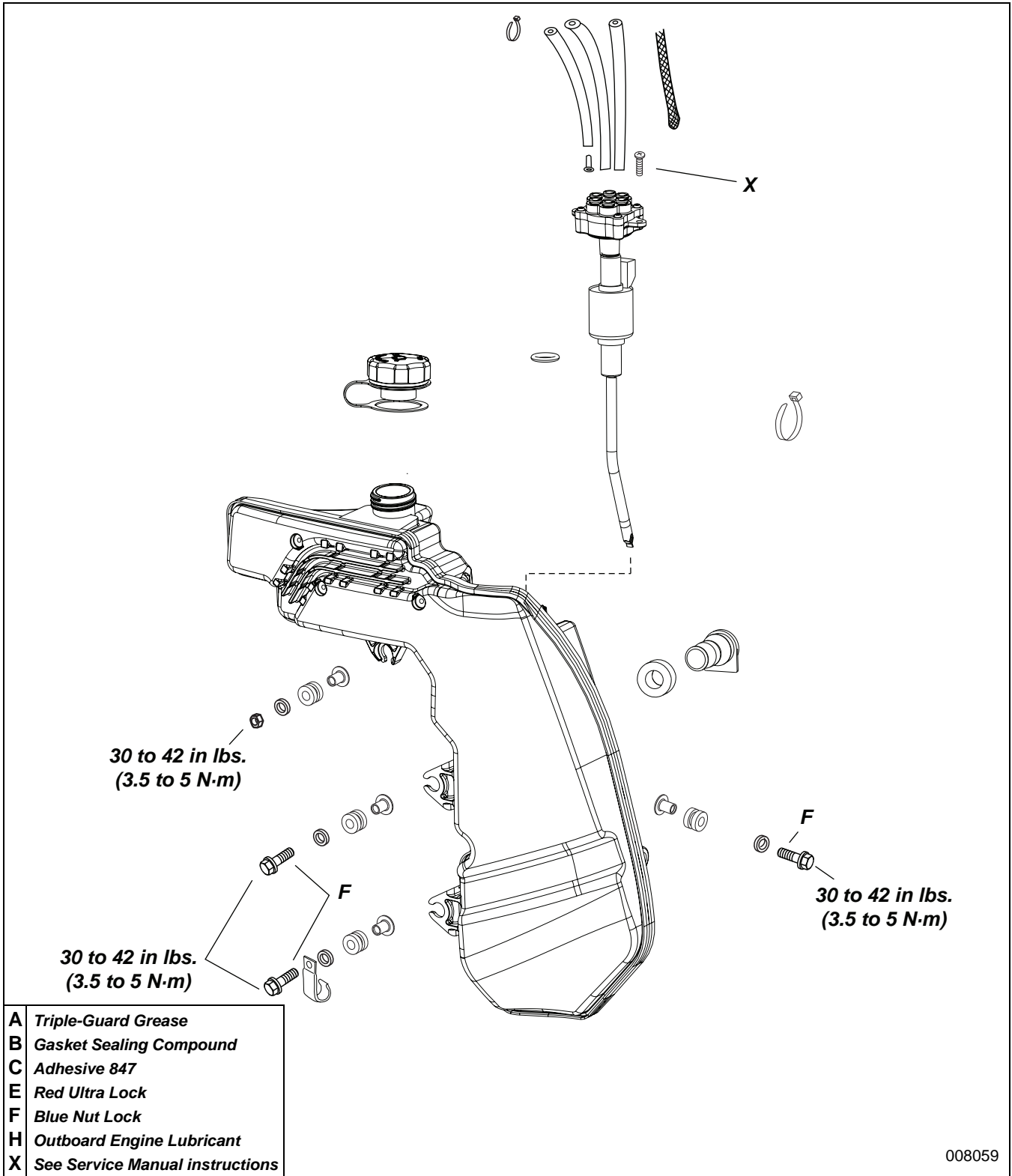

- A** Triple-Guard Grease
- B** Gasket Sealing Compound
- C** Adhesive 847
- E** Red Ultra Lock
- F** Blue Nut Lock
- H** Outboard Engine Lubricant
- X** See Service Manual instructions

008059

# OIL SUPPLY DIAGRAMS

40 – 65 HP

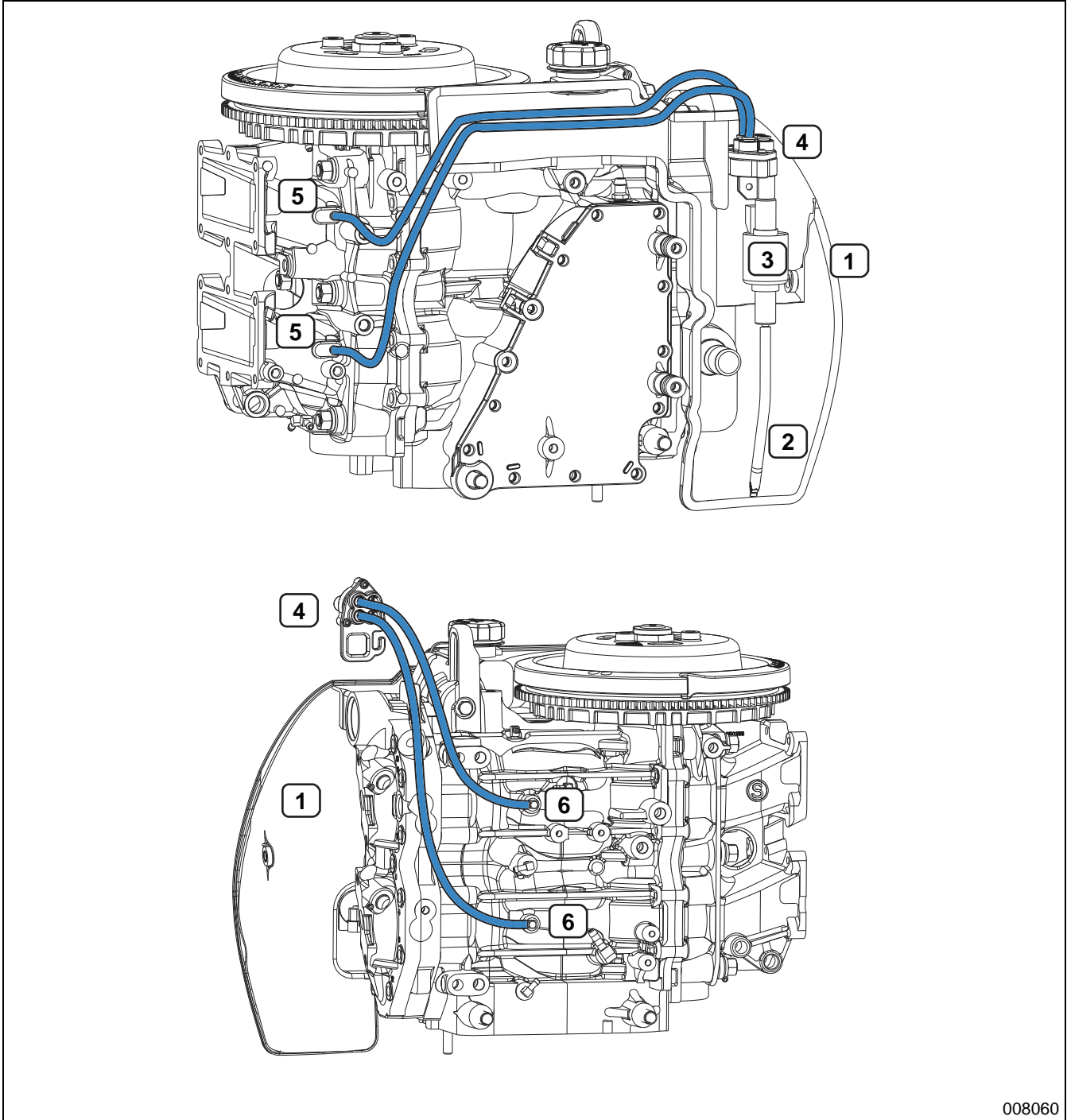

- |                       |                                   |
|-----------------------|-----------------------------------|
| 1. Oil tank           | 4. Oil distribution manifold      |
| 2. Oil pick-up/filter | 5. Crankcase oil inlet (port)     |
| 3. Oil injection pump | 6. Cylinder oil inlet (starboard) |



75 – 90 HP

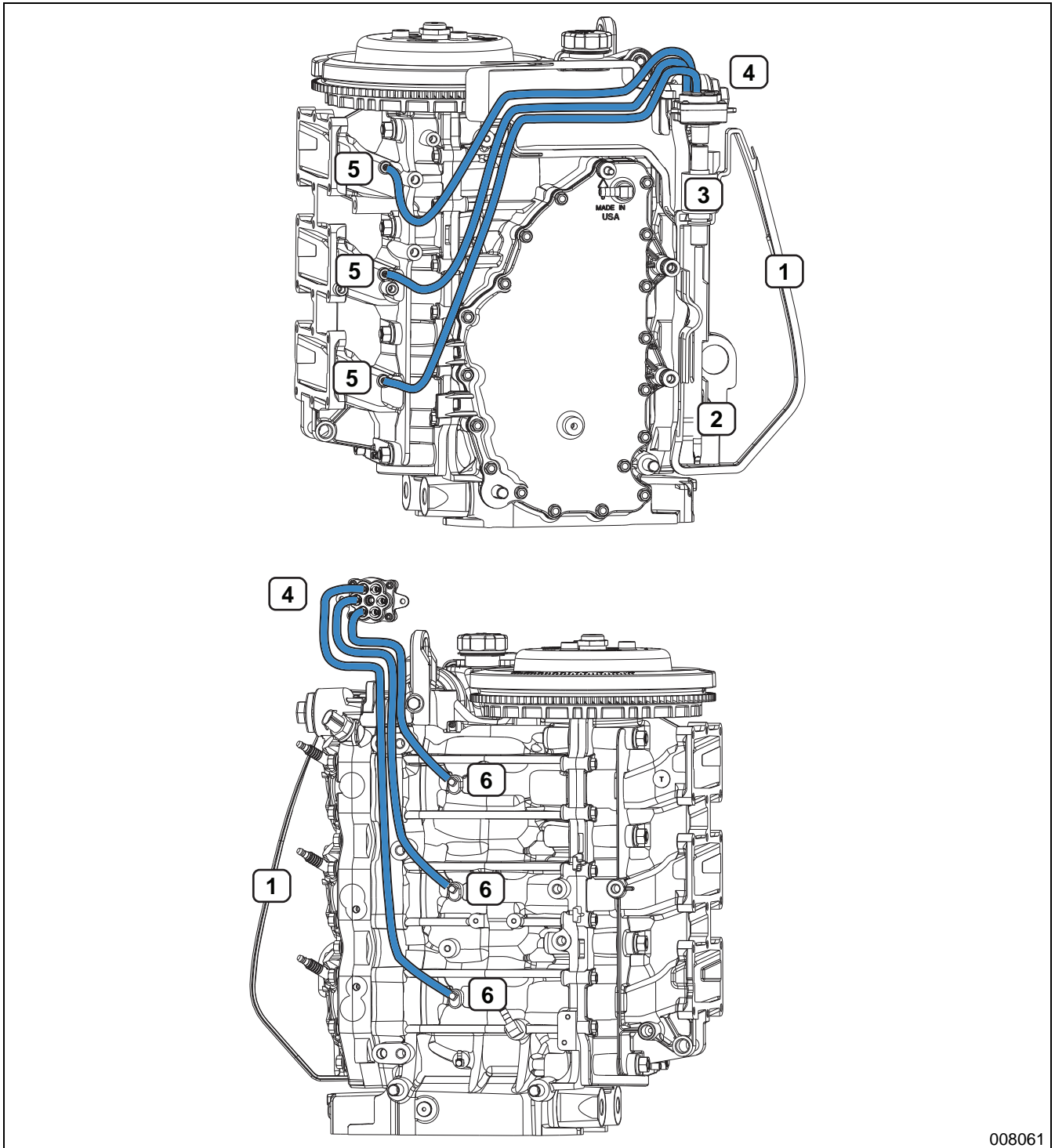

- |                       |                                   |
|-----------------------|-----------------------------------|
| 1. Oil tank           | 4. Oil distribution manifold      |
| 2. Oil pick-up/filter | 5. Crankcase oil inlet (port)     |
| 3. Oil injection pump | 6. Cylinder oil inlet (starboard) |

008061

# OIL RECIRCULATION DIAGRAMS

**40 – 65 HP**

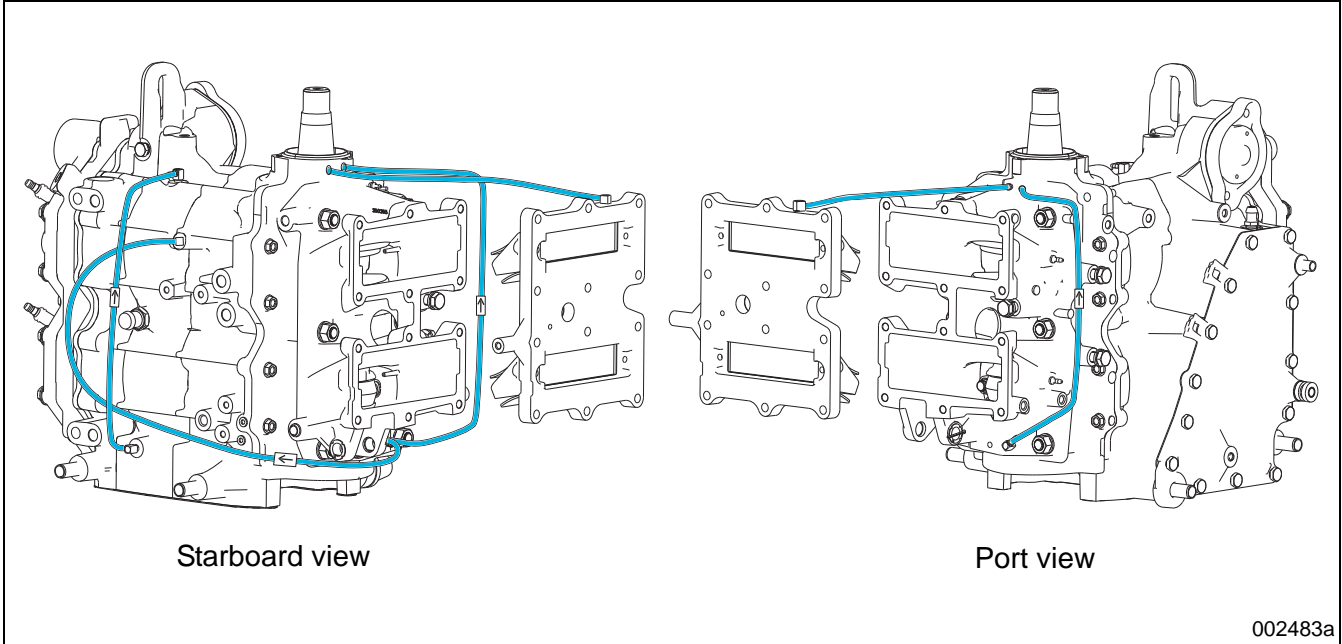

**75 – 90 HP**

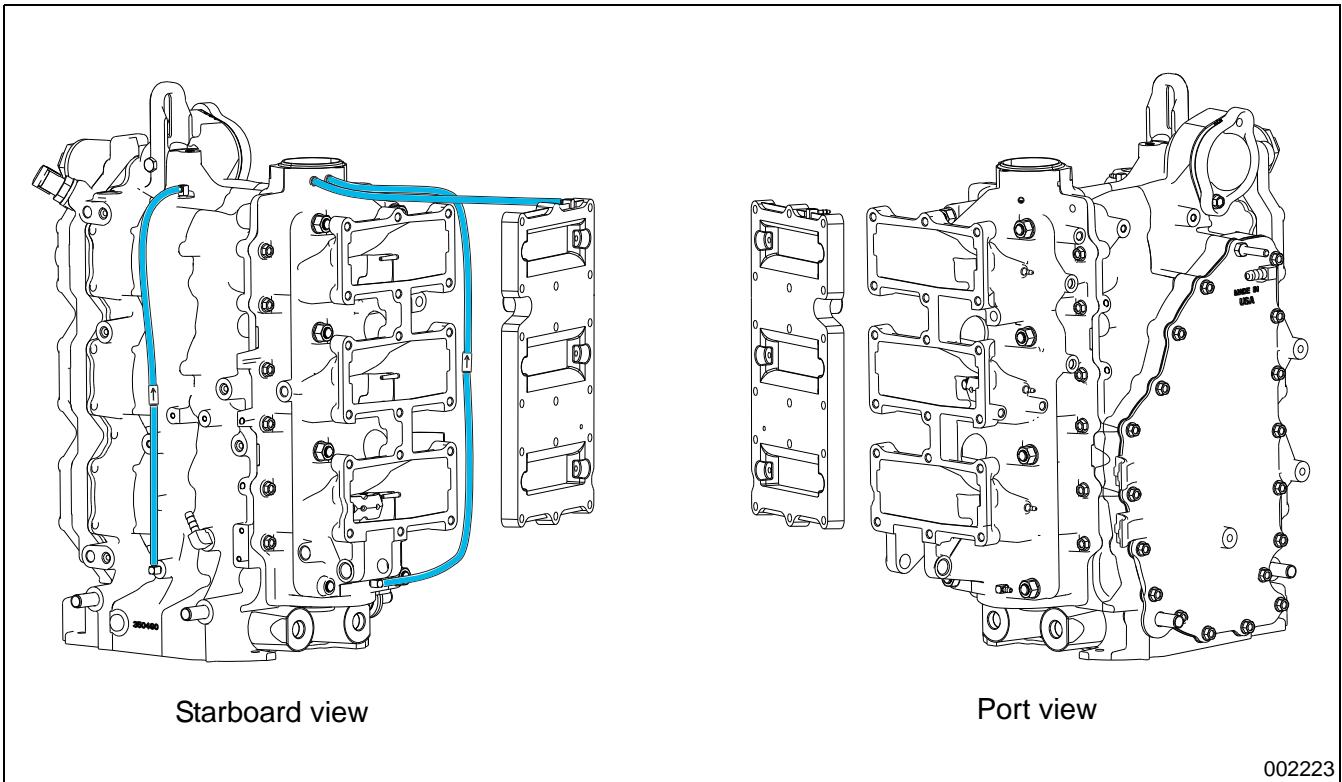

# OILING SYSTEM CIRCUIT DIAGRAM

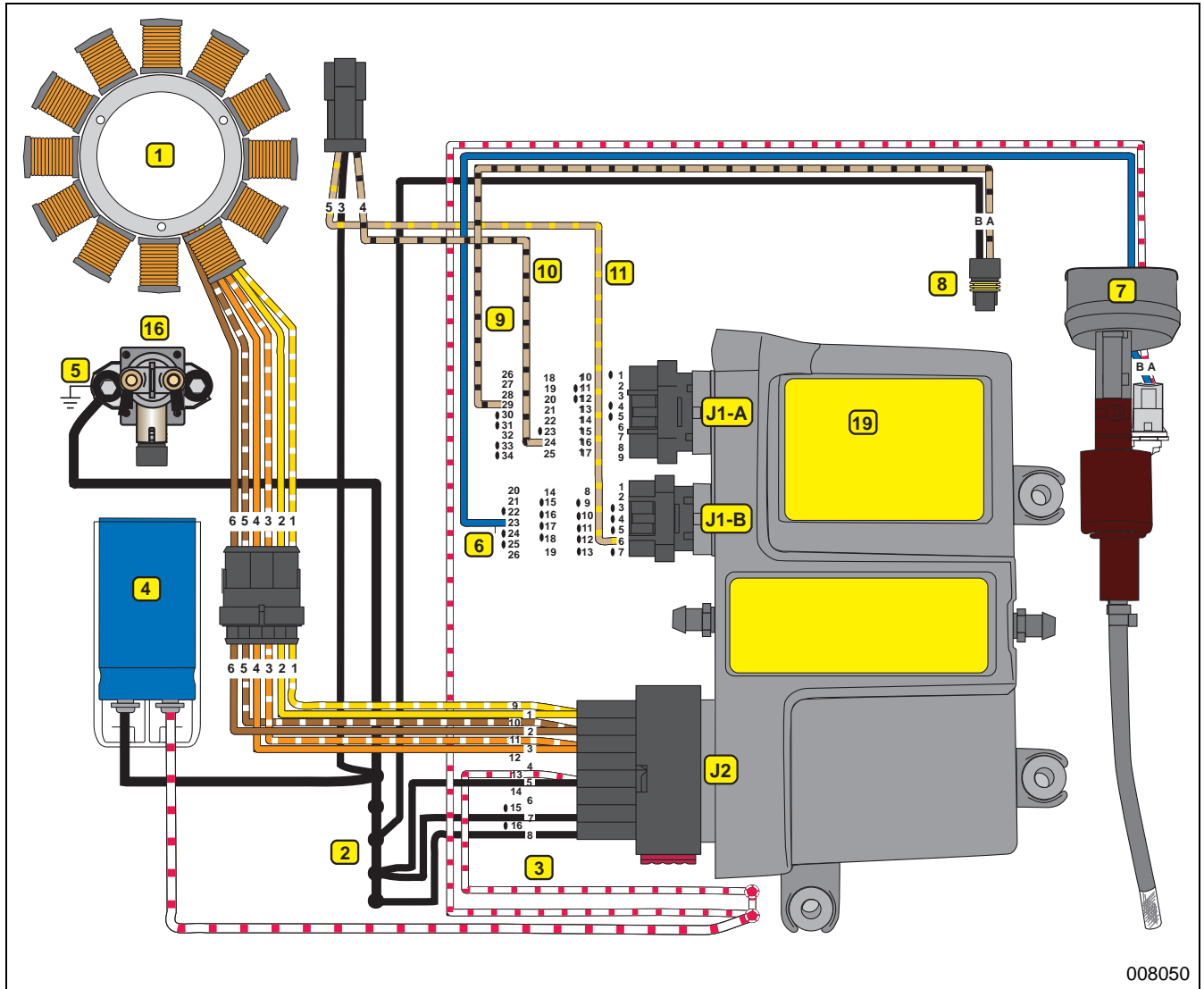

008050

1. Stator
2. Stator output (55 V)
3. Alternator grounds (BLACK)
4. Oil Injector ground (BLACK)
5. Alternator output, WHITE / RED wires (55 V)
6. Capacitor (55 V)
7. Main harness ground (BLACK)
8. 55 V to injection pump (WHITE / RED)
9. *EMM* injector control (BLUE)
10. Oil injection pump
11. Low oil switch
12. Low oil switch to *EMM* (TAN/BLACK)
13. Low oil signal to *SystemCheck* gauge (TAN/BLACK)
14. No oil signal to *SystemCheck* gauge (TAN/YELLOW)

## OIL SYSTEM REQUIREMENTS

### Recommended Lubricants

*Evinrude/Johnson XD100, XD50, or XD30* outboard oils are recommended for use in *Evinrude E-TEC* outboards. If these oils are not available, you must use a TC-W3 certified oil.

*Evinrude/Johnson XD100* outboard oil is highly recommended for all conditions and applications.

### Engine Lubricant Below 32°F (0°C)

If the outboard will be operated in temperatures below freezing (32°F, 0°C), use *Evinrude/Johnson XD100*.

**IMPORTANT:** For new outboards, test low oil warning before filling oil tank.

Turn key switch to ON. The engine monitor warning display should show “LOW OIL.”

Add enough oil to raise level to at least one-quarter capacity.

The “LOW OIL” warning should not display.

**NOTICE** Failure to follow these recommendations could void the outboard warranty if a lubrication-related failure occurs.

## COMPONENTS

The oiling system includes the following components:

- Oil tank
- Oil injection pump and manifold assembly
- Oil level switch
- Electrical circuit
- LOW OIL and NO OIL warning systems
- Cylinder and crankcase
- Oil recirculation system.

### Oil Tank Assembly

The oil tank is mounted on the powerhead under the engine cover. Oil level must be monitored.

#### 3-CYLINDER MODELS

Oil Tank Components:

- Tank, 2.4 quart. (2.3 liter) capacity
- Oil pickup and filter assembly
- Oil injection pump and manifold assembly
- LOW OIL switch
- Oil distribution hoses



008062

**2-CYLINDER MODELS**

Oil Tank Components:

- Tank, 2 quart. (1.87 liter) capacity
- Oil pickup and filter assembly
- Oil injection pump and manifold assembly
- LOW OIL switch
- Oil distribution hoses



008063

**Oil Injection Pump**

The oil injection pump is an electric (55 V) actuator style pump. It draws oil from the oil tank and supplies pressurized oil to the oil manifold. The *EMM* supplies 55 V and controls activation of the pump.

The oil manifold distributes the oil supplied by the pump.

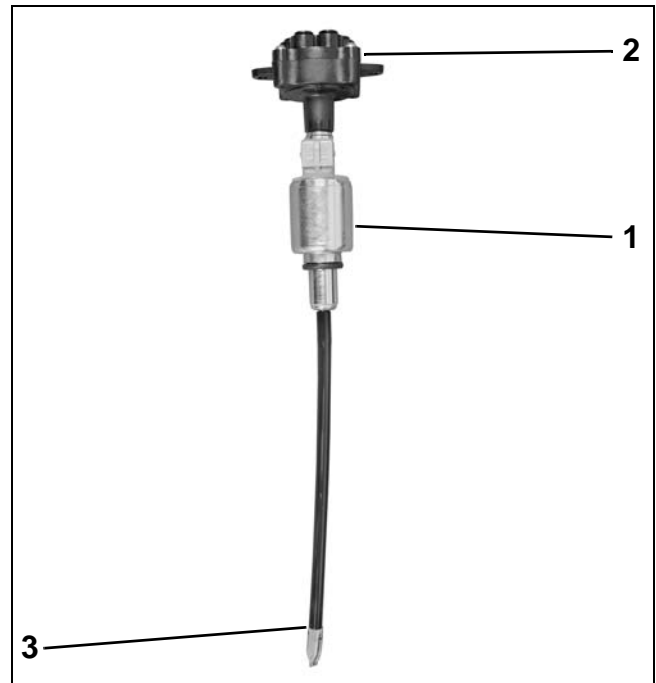

1. Oil injector pump
2. Oil distribution manifold
3. Pickup tube and filter

008064

**Electrical Circuit (55 V)**

The oil injector is powered by the 55 V electrical circuit. The *EMM* controls pump operation by rapidly connecting and disconnecting the pump's internal coil to ground.

The *EMM* monitors the oil injection pump electrical circuit. If circuit voltage is beyond the specified range, or the circuit is open, the *EMM*:

Activates <i>S.A.F.E.</i>
Stores a service code 34
<i>EMM</i> LED 4: ON (Running)
Engine Monitor NO OIL display: ON

## OILING SYSTEM COMPONENTS

### LOW OIL Warning

A switch in the oil tank assembly monitors the oil level in the oil tank.

If the oil level falls below one-quarter capacity, the *EMM* signals:

Engine Monitor LOW OIL display: ON
------------------------------------

Approximate oil reserve at Low Oil activation:

- 0.45 qt. (0.43 l).

### NO OIL Warning

When the oil level falls below one-quarter, the *EMM* begins counting oil pump pulse cycles. When it reaches:

- **40 – 65 HP:** 4800 pulses
- **75 – 90 HP:** 6000 pulses

the *EMM*:

Activates <i>S.A.F.E.</i>
---------------------------

Stores service code 117
-------------------------

<i>EMM</i> LED 4: ON (Running)
--------------------------------

Engine Monitor NO OIL display: ON
-----------------------------------

To recover from *S.A.F.E.* mode:

- Oil level must be above one-quarter
- The warning resets after three oil pump pulse cycles when the outboard has been stopped and restarted.

If outboard has been run for more than 3 hours with NO OIL faults (codes 34 & 117), the *EMM*

Activates SHUTDOWN
--------------------

Stores service code 33
------------------------

<i>EMM</i> LED 4: FLASHING
----------------------------

Engine Monitor NO OIL display: FLASHING
---

### Cylinder and Crankcase

The oil distribution manifold provides crankcase lubrication through oil distribution hoses and pressed-in fittings on the crankcase and cylinder block.

#### 3-CYLINDER MODELS

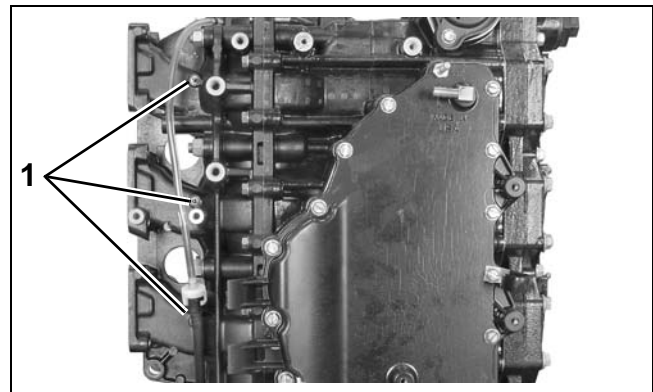

1. Crankcase oil fittings

006758

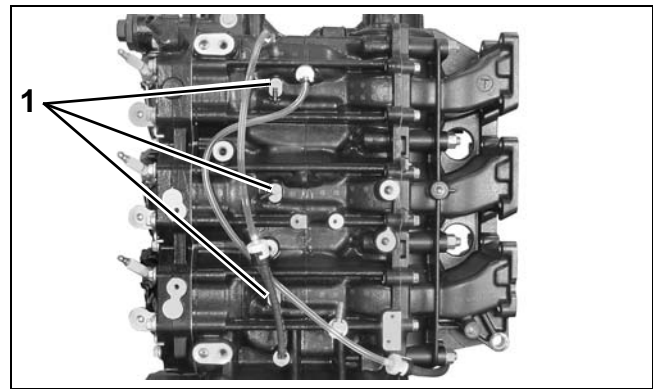

1. Cylinder block oil fittings

006759

**2-CYLINDER MODELS**

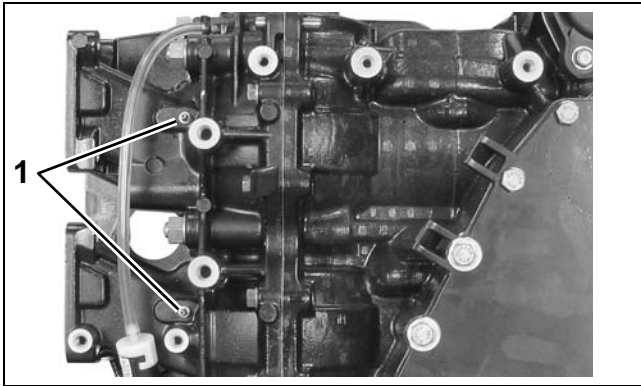

1. Crankcase oil fittings

006614

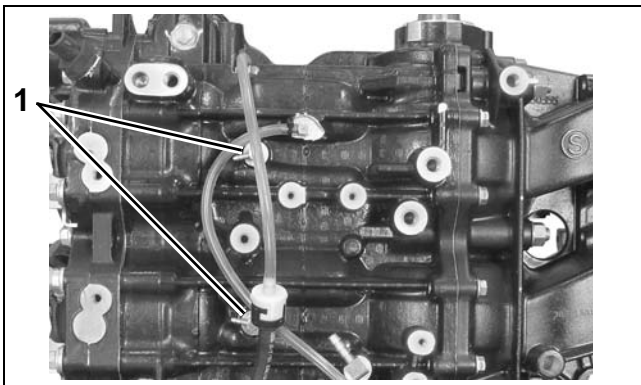

1. Cylinder block oil fittings

006615

**Oil Recirculation System**

External hoses and fittings, internal cylinder/crankcase passages, and intake manifold passages are used to recirculate any accumulation of oil from various locations in the powerhead. The movement of oil is controlled by check valves.

**Cylinder Recirculation**

Internal powerhead oil drain passages connect the intake port areas of the cylinders to circulate residual oil in the block.

External fittings and in-line check valves on each side of the cylinder block control the movement of oil from the lower cylinder port to the upper cylinder port.

**Crankcase / Main Bearing Recirculation**

The movement of oil through the main bearings is controlled by internal passages, external fittings and hoses, and check valves.

**Lower to upper main bearing oil flow:**

- Lower main bearing cavity to internal crankcase passage to external fitting, external hoses with in-line check valve to external fitting at upper main bearing, and into upper main bearing through internal crankcase passage.
- Internal crankcase passage to external fitting in crankcase cover at upper main bearing, hose routed to reed plate fitting. This circuit vents the upper main bearing cavity to promote oil flow.

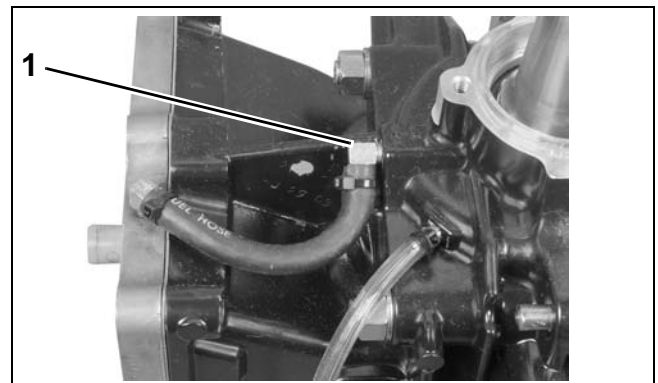

1. Upper main bearing vent

002399

Refer to the **OIL RECIRCULATION DIAGRAMS** on p. 158.

# OIL CONTROL SETTINGS

## Oil Injection Rate

*EMM* programming controls the rate of oil injection based on engine RPM. This rate can be adjusted for the type of oil being used, and also for powerhead break-in. Use *Evinrude Diagnostics* software to access these features.

The *Set Oil Type* option controls the injection rate for the oil being used and typical operating conditions.

The TC-W3 oil type setting is the standard setting for all outboards. Set TC-W3 for:

- Operation with all TC-W3 outboard oils including *XD30*, *XD50*, or *XD100*.
- Applications requiring maximum lubrication.
- Extreme applications (commercial or harsh conditions, racing or other high performance operation).
- Use this setting with *XD100* outboard oil in extreme applications

The *XD100* setting provides an option to run the outboard at a reduced oil injection rate. This setting **REQUIRES** the use of *Evinrude XD100* outboard lubricant and is not recommended for all applications.

**IMPORTANT:** The *XD100* setting is not available on all models.

Use the *XD100* setting for:

- Conventional use (runabouts, cruisers)
- Moderate applications

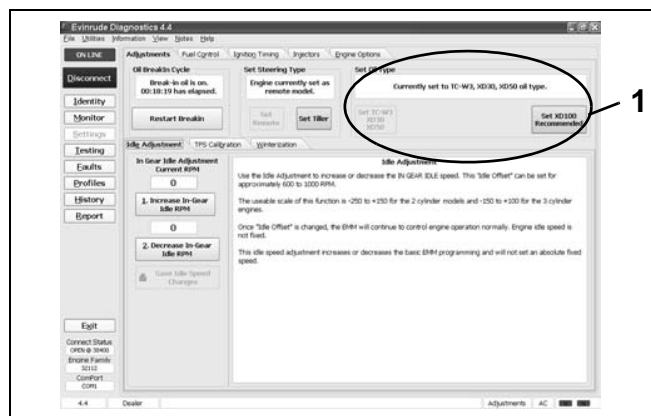

1. Oil control setting

008084

**⚠ CAUTION**

Running an *Evinrude E-TEC* outboard on other grades of oil while set to the *XD100* oil ratio will result in increased engine wear and shortened outboard life.

Powerhead oil programming labels are provided to identify *EMM* oil programming. Install the correct label to alert user to specific oil requirements.

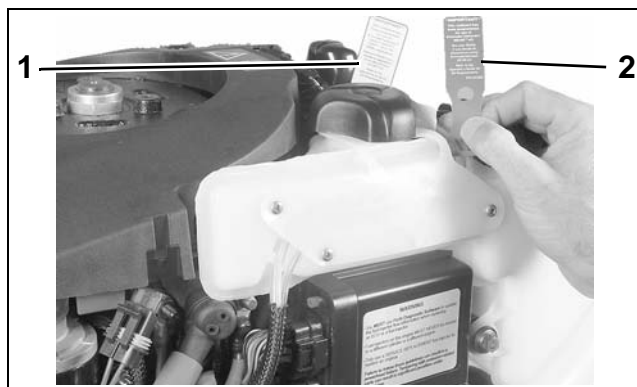

1. Evinrude/Johnson *XD30* outboard lubricant (TC-W3) 002507 **YELLOW label**
2. Evinrude/Johnson *XD100* outboard lubricant (Premium) **BLUE label (Installed)**

An *XD100* Outboard Oil Decal, P/N 352369, is available to label boats equipped with outboards that have been programmed for the reduced oil injection ratio.

**\*IMPORTANT\***

This outboard has been programmed for the use of Evinrude®/Johnson® **XD100™** outboard oil **ONLY**.

Failure to use Evinrude/Johnson *XD100* outboard oil may harm engine performance and shorten engine life.

EVINRUDE.COM P/N 352369

*XD100* Outboard Oil Decal

004522



Install decals in a highly visible location, such as one of the following:

- Dashboard/deck of boat, next to key switch
- Deck of boat, next to the remote oil fill
- Deck of boat, next to oil tank assembly
- Oil tank cover
- Cover of oil tank compartment
- Attach to oil tank or oil fill cap.

**IMPORTANT:** Make sure the engine label and boat decals match *EMM* programming.

## Break-In Oiling

**IMPORTANT:** DO NOT add oil in the fuel tank on *Evinrude E-TEC* models.

The *EMM* automatically supplies extra oil to the engine as follows:

- 40 – 90 HP: First two hours above 2000 RPM

Follow these steps for outboard set-up:

- Use *Evinrude Diagnostics* software to make sure the break-in program has been started on a new outboard.
- Use the diagnostics software to start break-in oiling after a powerhead rebuild.

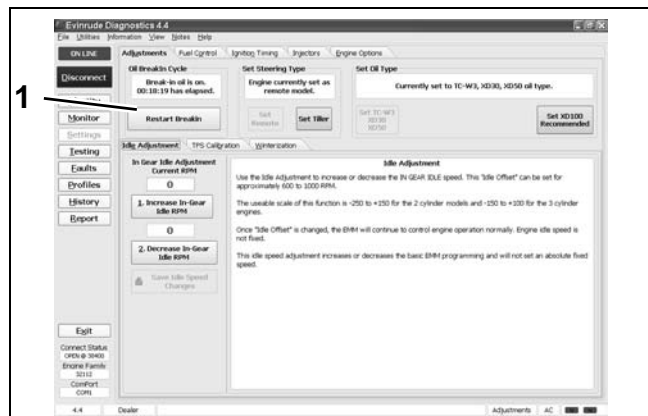

1. Break-in oil setting

008084

**NOTICE** The operator must monitor the oil tank level to confirm oil consumption. This may require several hours of operation above idle.

## Oil Supply Priming

### ⚠ WARNING

Always use caution while working around machinery with moving parts. The following set-up procedures require running tests that are performed with the outboard's motor cover removed.

Start the outboard. Use the oil priming function in the software to make sure the system is completely primed.

Use the *Prime Oil System* button of the *Dynamic Test* screen to prime the oil pump.

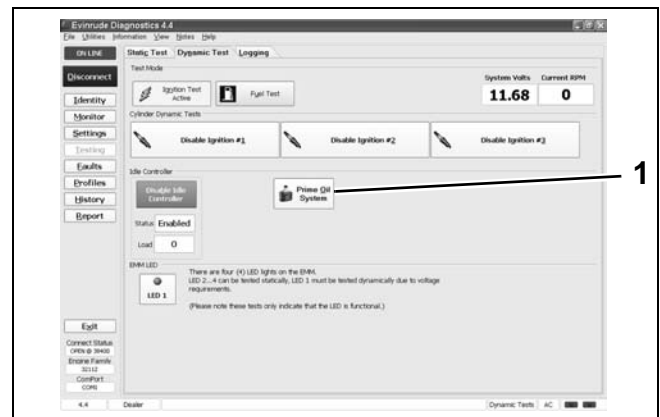

Dynamic Test Screen

1. Prime Oil System button

008083

## OILING SYSTEM

### OILING SYSTEM TESTS

Observe oil flow through all oil distribution hoses. Air must be purged during the priming procedure.

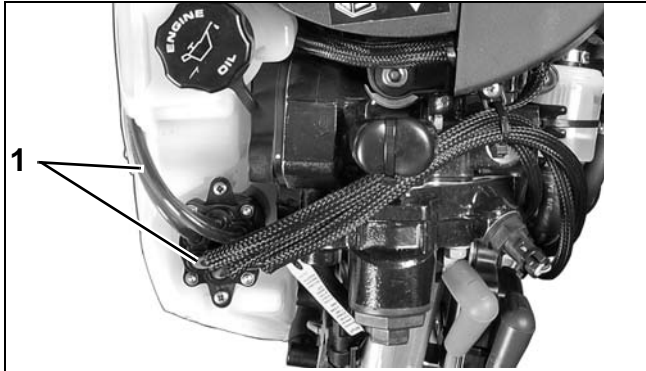

1. Oil distribution hoses 007997

Small bubbles are acceptable. Large bubbles must be eliminated through continued priming.

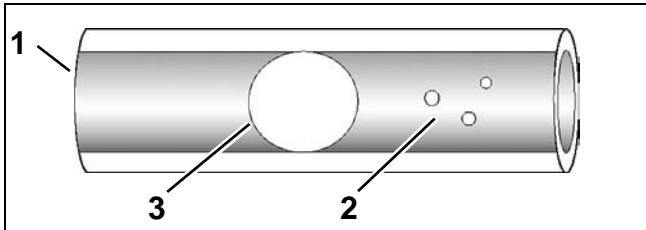

1. Oil distribution hose  
2. Small bubbles  
3. Large bubbles 004398

Repair any fuel or oil leaks.

The oiling system on these models can also be primed using the Self-Winterizing feature if diagnostics software is not available. Refer to **STORAGE** on p. 45.

## OILING SYSTEM TESTS

**IMPORTANT:** Always perform visual inspections to identify oiling system leaks. Make sure the oil tank is filled and oil supply is not contaminated.

### Oil Injection Pump Voltage Tests

**IMPORTANT:** Do NOT perform static tests using Diagnostic Power Supply Tool, P/N 587005, with internal 9 volt batteries only. This will produce false results. Refer to **Communication** on p. 63.

The *EMM* controls the pump by providing ground through pin 23 (blue wire) of the J1-B connector and pin B (blue wire) of the oil pump connector.

Acceptable Oil Injection Pump Test Readings	
Key switch ON	approximately 12 VDC
Control signal	approximately 5 Hz
Engine running	approximately 55 VDC

Use a digital multimeter calibrated to a scale that reads 12 V (DC) to measure voltage between the oil pump electrical connector and engine ground.

Connect negative meter lead to ground.

Use an appropriate test probe to connect positive meter lead to pin B (blue wire) of oil injection pump electrical connector.

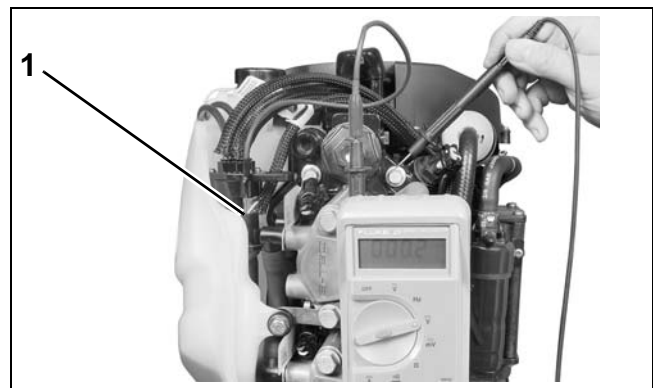

1. Oil injection pump electrical connector 008065

Turn the key switch to the ON position. Observe voltage at pin B.

- Voltage at pin B should be approximately 12 V.

Use the *Oil Injector* test of *Evinrude Diagnostic* software *Static Test* screen to activate the oil pump.

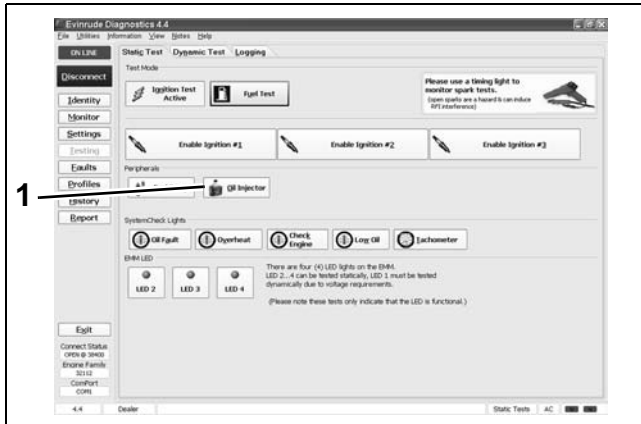

**Static Tests Screen**  
1. *Oil injector test button*

008082A

**IMPORTANT:** This test is operating the pump with 12 V battery power on the system voltage (55 V) circuit. The oil injection pump will not pump oil when operating on 12 V.

Observe voltage at pin B.

- Voltage at pin B should drop as the oil pump cycles.

Check the control signal while the *Oil Injector* test is running. Set the digital multimeter to the Hertz (Hz) scale.

- Meter should read approximately 5 Hz.

Results:

- If voltage and control signal readings at pin B are within range, the *EMM* and wiring are not at fault.
- If voltage at pin B is not within range, check voltage at pin A (white/red wire) of oil pump electrical connector.

Connect positive meter lead to pin A (white/red wire) of oil injection pump electrical connector. Observe voltage at pin A.

- Voltage at pin A should be approximately 12 V.

Set digital multimeter to a scale that reads 55 V (DC).

Start the engine. Observe voltage at pin A.

- Voltage at pin A should be approximately 55 V.
- If voltage at pin A is within range, refer to **Oil Injection Pump Resistance Test** on p. 167.
- No voltage reading at pin A, refer to **System Voltage Test** on p. 80.

## Oil Injection Pump Resistance Test

Disconnect the battery cables at the battery.

Disconnect the electrical connector from the oil injection pump.

Use a digital multimeter to measure the resistance between the pins of the oil injection pump connector. Calibrate the meter to the LOW OHMS scale.

Oil Injection Pump Circuit Resistance
22 Ω

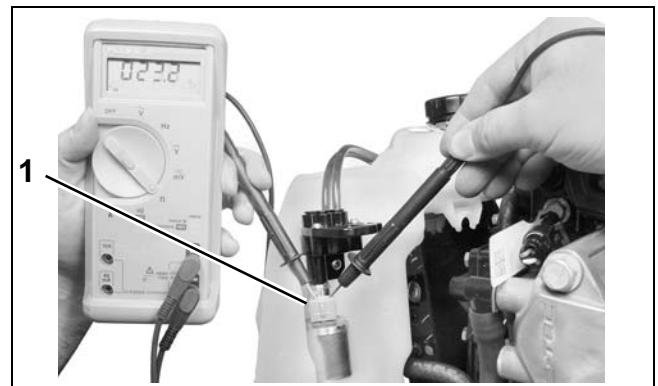

1. *Oil injection pump connector*

008420

Results:

- An infinite reading ( $\infty$ ) indicates an open circuit of the injection pump winding. Replace faulty pump.

## OILING SYSTEM

### OILING SYSTEM TESTS

#### Oil Injection Pump Function Test

Remove oil distribution hose from fitting at oil distribution manifold. Do not lose the brass hose support.

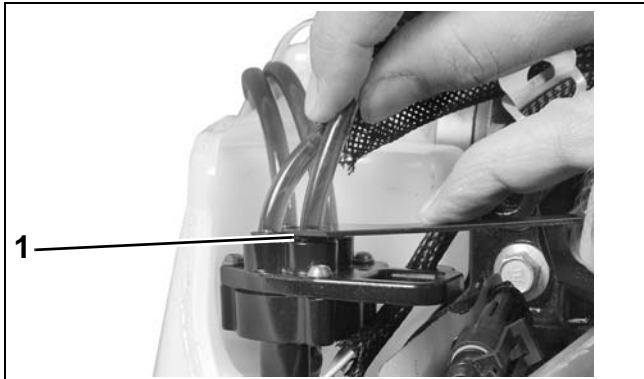

1. Retainer mechanism

008067

Temporarily install a length of oil hose.

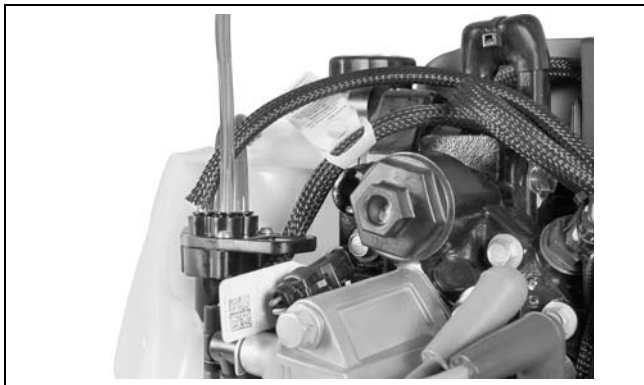

008068

Start the outboard and observe oil flow:

- Oil flows from hose, compare to oil flow at other distribution fittings
- If one or more fittings fail to flow oil, replace the oil injection pump assembly.

Reinstall hose into manifold.

**IMPORTANT:** Make sure hose support is in hose and hose is fully inserted into manifold. Refer to **Oil Distribution Hoses** on p. 169.

#### Oil Injection Fittings Flow Test

Make sure the oil injection fittings of the cylinder and crankcase assembly allow fluid to move.

Remove oil distribution hose from oil distribution manifold.

Use a Syringe, P/N 346936, filled with isopropyl alcohol to force fluid through hose and fitting.

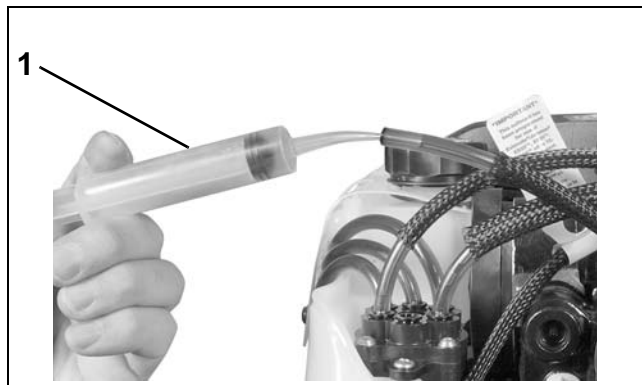

1. Syringe

008069

#### LOW OIL Sending Unit Test

Remove oil from the oil tank.

Turn the key switch ON. The dash mounted Engine Monitor system should show a LOW OIL warning.

Once the warning has been confirmed, refill the oil tank and start the outboard. The LOW OIL warning should stop after the oil pump cycles 3 times.

# OIL COMPONENT SERVICING

## WARNING

To prevent accidental starting while servicing, twist and remove spark plug leads.

## Oil Distribution Hoses

The oil distribution hoses to each cylinder MUST be the same length. DO NOT alter the length of any hoses.

Oil Distribution Hose Length:

- 20 in. (508 mm)

### Removal

Release the hose by depressing the outer ring of the hose retaining mechanism.

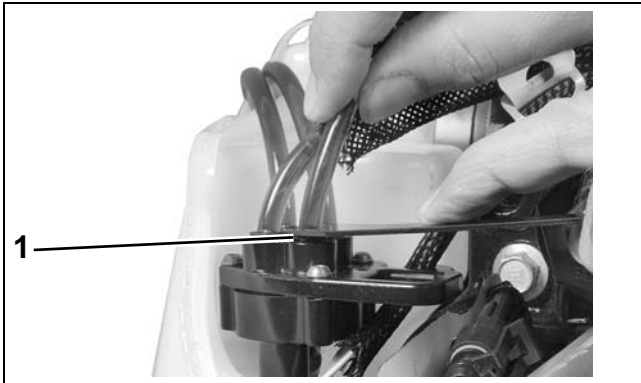

1. Retainer mechanism

008067

Once hose is removed from the manifold, make sure hose support is in the end of the hose.

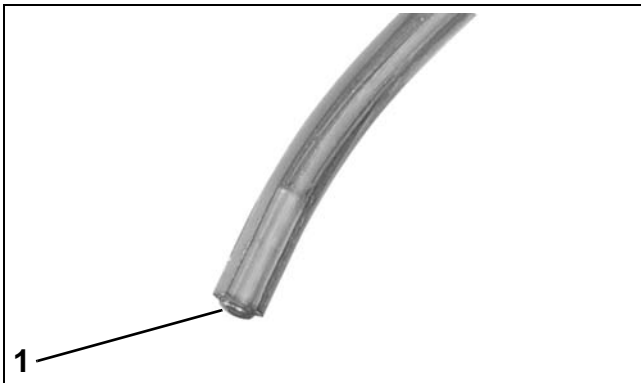

1. Hose support

008070

### Installation

Cut Replacement Oil Hose, P/N 778708, to the correct length. Insert hose support in manifold end of hose.

**IMPORTANT:** DO NOT insert distribution hoses into manifold without a hose support.

Be sure the hose is fully inserted into manifold. Insertion depth is 5/8 in. (16 mm). Visually inspect for hose supports.

## Oil Tank Assembly

### Removal

Disconnect the battery cables at the battery.

Remove engine covers and air silencer.

Remove oil tank retaining screws.

### 3-CYLINDER MODELS

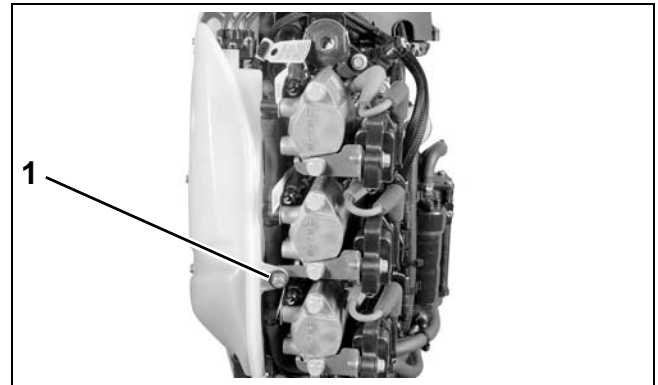

1. Screw

008071

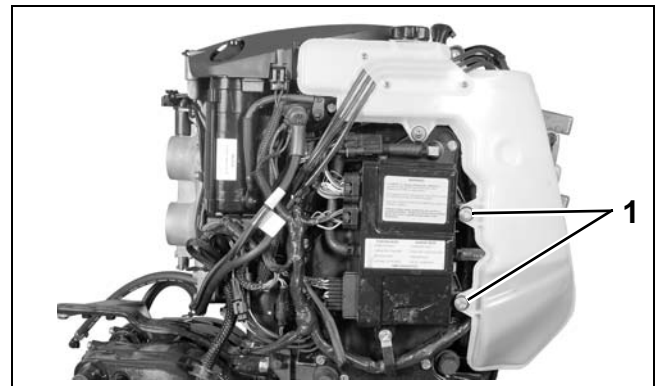

1. Screws

008072

# OILING SYSTEM

## OIL COMPONENT SERVICING

### 2-CYLINDER MODELS

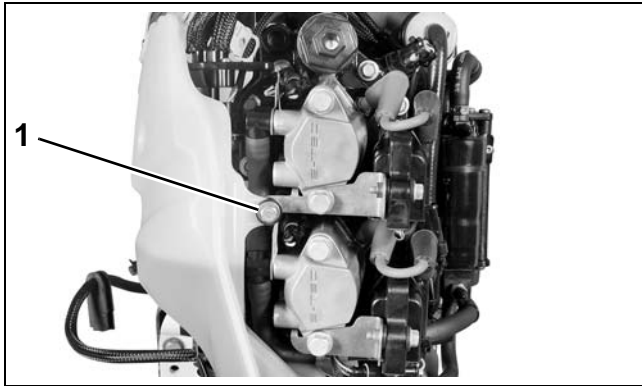

1. Screw 008073



1. Screws 008074

### ALL MODELS

Disconnect the electrical connector to the oil injection pump and manifold assembly.

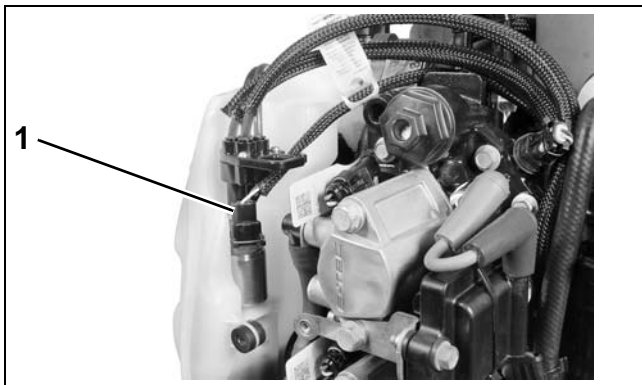

1. Oil pump connector 008075

Disconnect the electrical connector to the low oil switch.

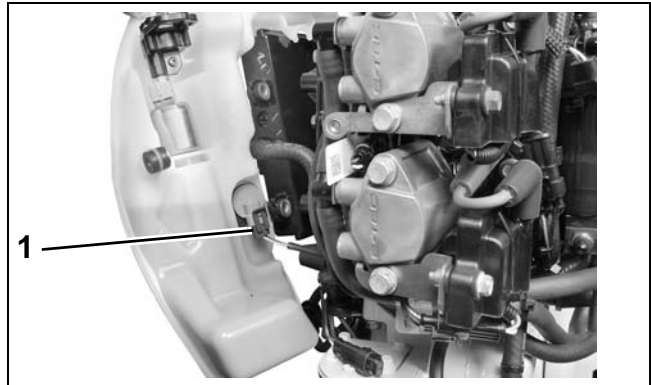

1. Low oil switch connector 008076

**IMPORTANT:** Note oil distribution hose routings before proceeding with disassembly.

Remove oil distribution hoses from the manifold.

### Installation

Position oil tank assembly on powerhead. Clean mounting screws and apply *Nut Lock* to threads. Install screws and tighten to a torque of 30 to 42 in. lbs. (3.5 to 5 N·m).

Install protective sleeves and route oil distribution hoses from the oil distribution manifold to the crankcase oil delivery fittings. Refer to **OIL SUPPLY DIAGRAMS** on p. 156. Secure oil hoses to crankcase fittings with tie straps.

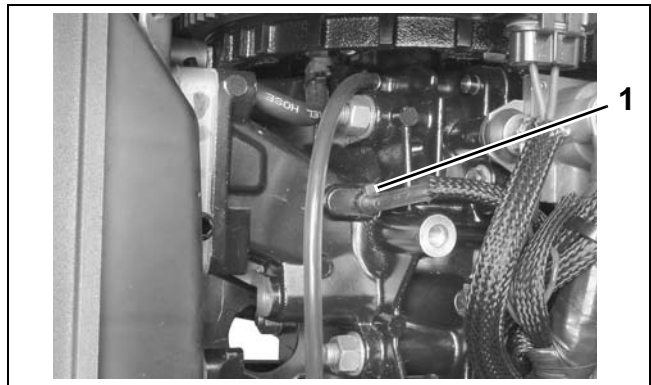

1. Tie strap 006573

Run outboard and check for leaks. Use *Evinrude Diagnostics* software to activate "Oil Prime." Check oil flow through oil distribution hoses. Check oil system operation and routing of oil system hoses.

Repair any oil leaks and kinked or misrouted hoses. Install air silencer and engine covers.

# Oil Injection Pump

## Removal

Remove oil distribution hoses from oil manifold. Refer to **Oil Distribution Hoses** on p. 169.

Remove oil from oil tank.

Remove oil tank. Refer to **Oil Tank Assembly** on p. 169. Remove retaining screw(s) from oil pump assembly. Twist and pull up on oil pump to remove from tank. **DO NOT** pull up on oil manifold.

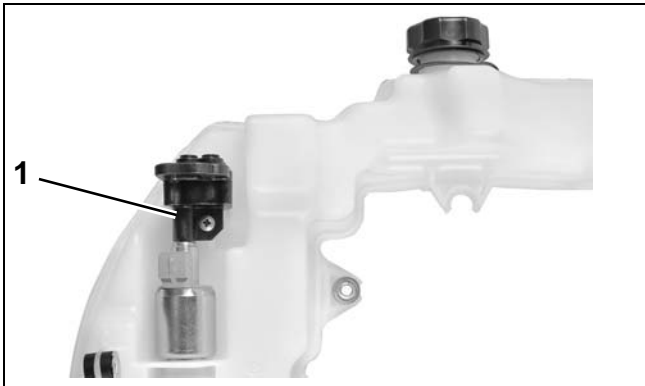

**2-Cylinder Models**  
1. Screw

008180

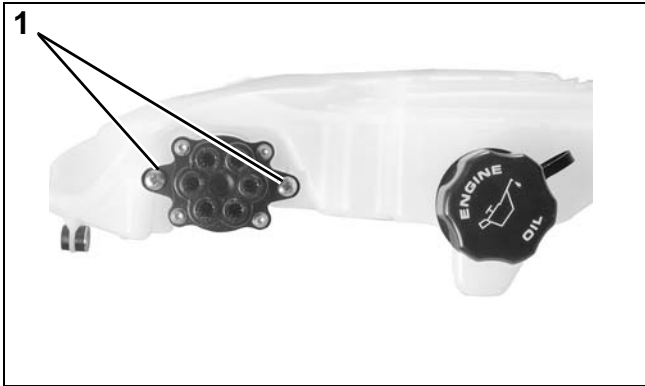

**3-Cylinder Models**  
1. Screws

008181

## Installation

Apply a drop of outboard lubricant to a new oil pump o-ring. Install o-ring on oil pump flange.

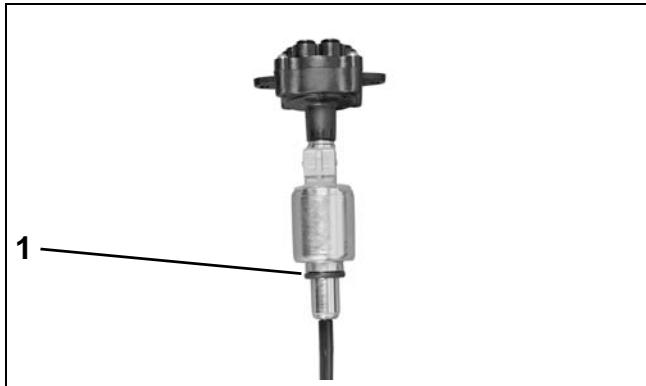

1. O-ring

008064

## 2-CYLINDER MODELS

Install oil pump and manifold so that bend of oil pick up assembly is positioned to follow the contour of the oil tank as shown.

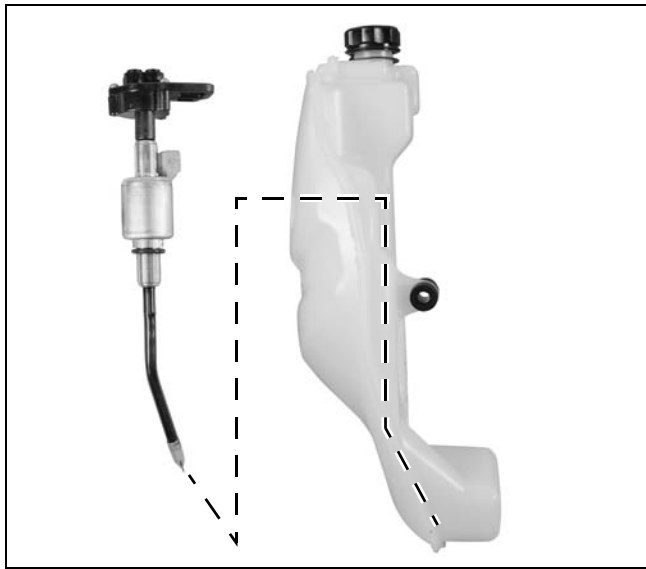

008182

---

## OILING SYSTEM

### OIL COMPONENT SERVICING

---

#### **3-CYLINDER MODELS**

Install oil pump and manifold straight into oil tank.

**IMPORTANT:** Be sure oil pick up assembly is positioned **in front of** oil tank baffle to prevent interference with the LOW OIL switch.

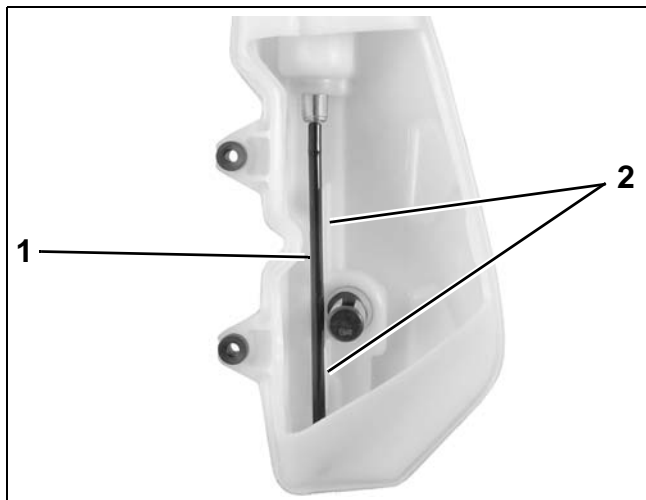

1. Oil pick up assembly
2. Oil tank baffle

008183

#### **ALL MODELS**

Install oil pump retainer screw(s). Tighten securely.

**IMPORTANT:** Turn self-tapping screws counter clock-wise to start the threads and clockwise to tighten. Failure to follow this procedure can damage the threads of the oil tank.



# COOLING SYSTEM

## TABLE OF CONTENTS

- HOSE ROUTING AND WATER FLOW DIAGRAMS .....174
- COMPONENTS .....176
  - WATER PUMP AND INTAKES .....176
  - EXHAUST HOUSING .....176
  - WATER SUPPLY TUBE .....176
  - ADAPTER/INNER EXHAUST HOUSING .....177
  - PRESSURE RELIEF VALVE .....177
  - THERMOSTAT .....177
  - BLOCK VENTING .....178
  - WATER PRESSURE CONNECTION .....178
- OPERATION .....179
  - CYLINDER BLOCK / CYLINDER HEAD COOLING .....179
  - EMM AND VAPOR SEPARATOR COOLING .....179
- ENGINE TEMPERATURE CHECK .....180
  - SOFTWARE METHOD .....180
  - PYROMETER METHOD .....181
- TEMPERATURE SENDER SERVICING .....182
  - REMOVAL .....182
  - INSTALLATION .....182
- THERMOSTAT SERVICING .....182
  - DISASSEMBLY .....182
  - INSPECTION .....183
  - ASSEMBLY .....183
- PRESSURE RELIEF VALVE SERVICING .....183
  - DISASSEMBLY .....183
  - INSPECTION .....184
  - ASSEMBLY .....184

# HOSE ROUTING AND WATER FLOW DIAGRAMS

2-CYLINDER MODELS

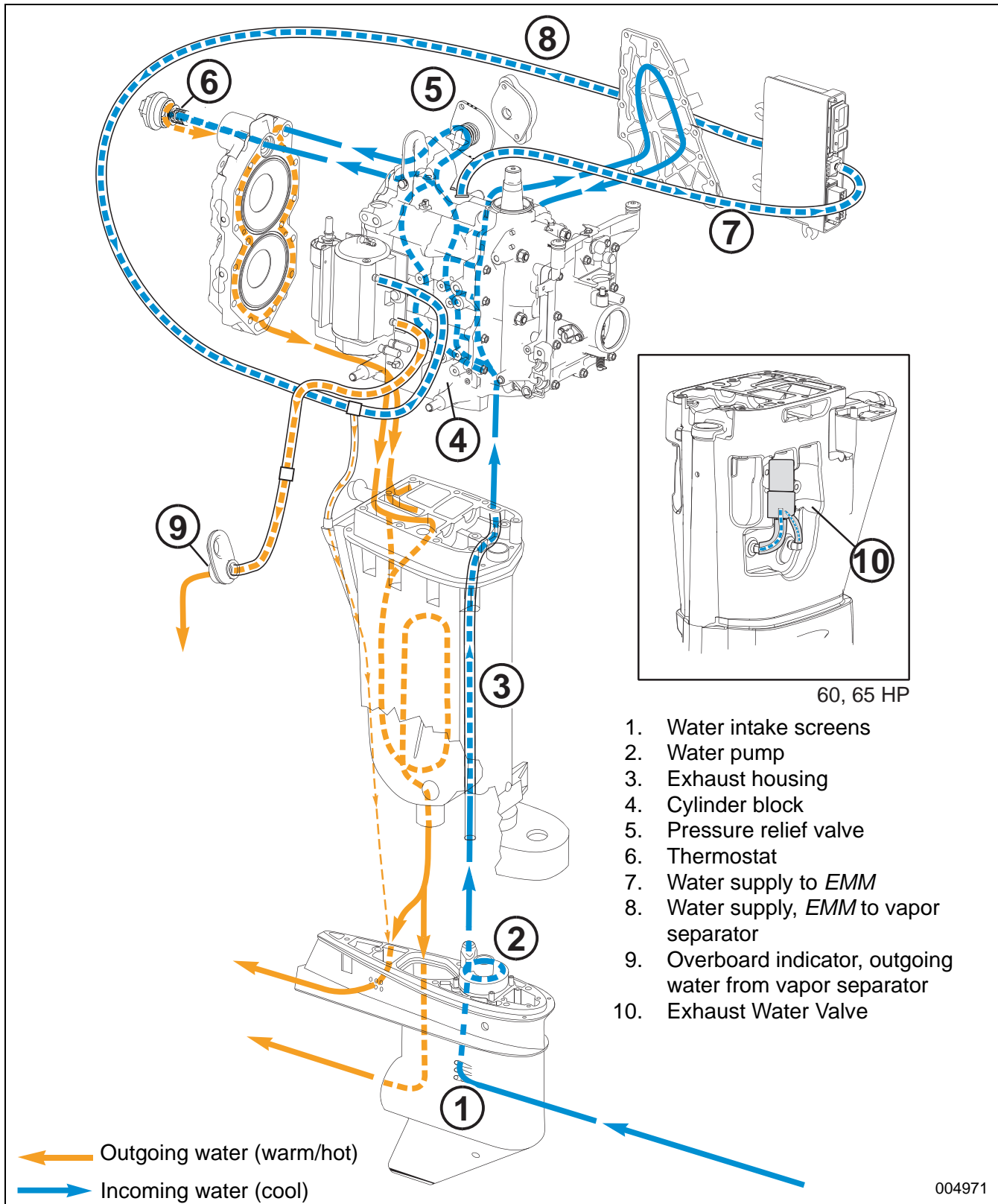

004971

**3-CYLINDER MODELS**

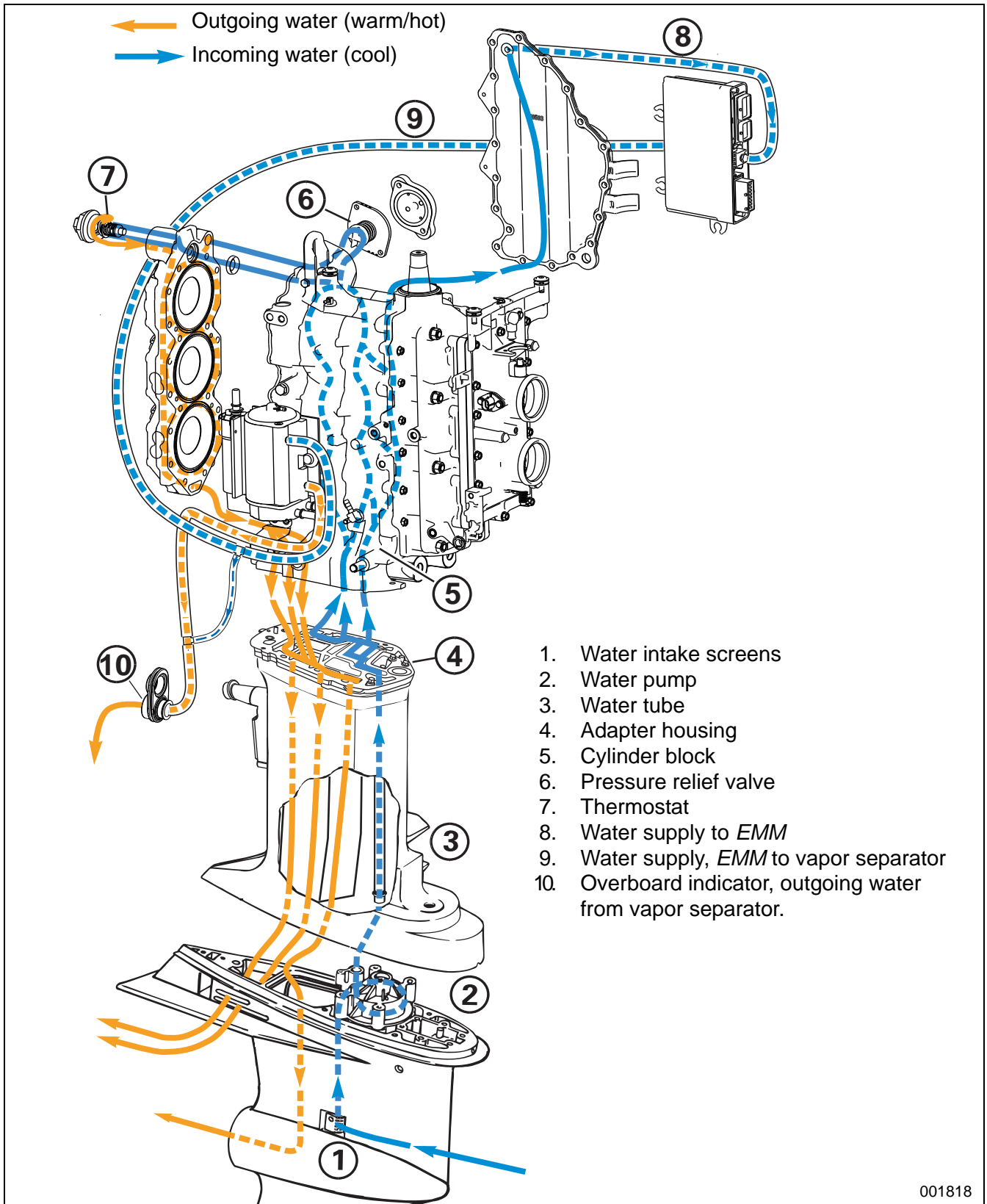

**9**

001818

# COMPONENTS

## Water Pump and Intakes

External water intakes mounted in the gearcase housing collect water and must supply the inlet side of the water pump with an unrestricted and unaerated water supply. Water is drawn into the water pump through a hole in the lower plate of the water pump assembly. All cooling water to the powerhead is provided by the water pump.

- A nylon wedge (impeller key) is used to engage the impeller bushing and driveshaft.
- The nylon impeller housing with liner must seal against a separate water pump plate.
- The bottom plate **MUST** seal to gearcase.
- The pump operates as a positive displacement pump at **LOW** speeds (below 1500 RPM) and as a centrifugal pump at **HIGHER** speeds.

Refer to **WATER PUMP SERVICE** on p. 298, or **WATER PUMP SERVICE** on p. 320 for servicing.

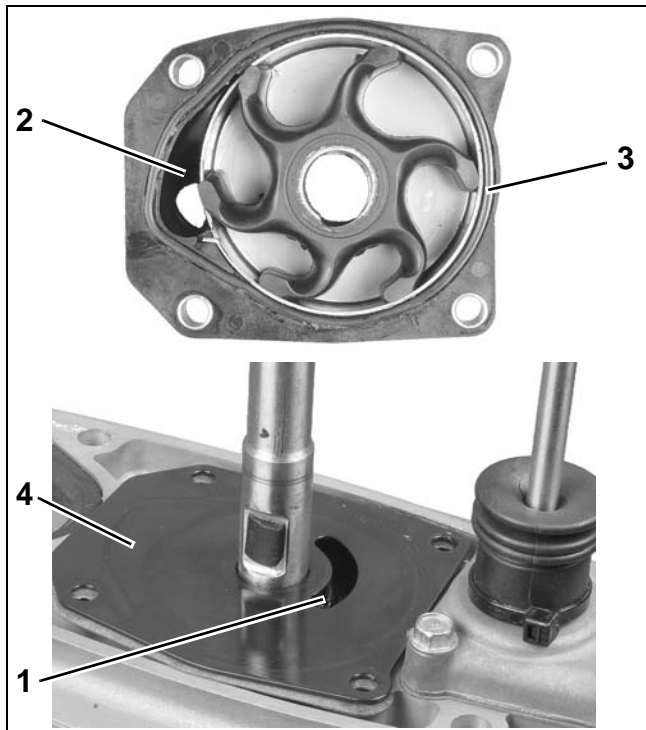

1. Water inlet  
2. Water outlet  
3. Seal  
4. Plate

001216  
001217

**IMPORTANT:** The water pump housing on 2-cylinder models includes a small hole to the rear of the water outlet. This hole provides cooling water for the tip of the exhaust passage. Be sure to use the correct parts when replacing the water pump.



1. Hole

004970

## Exhaust Housing

### 2-CYLINDER MODELS

The water pump outlet connects with passages located in the outboard's midsection. A grommet seals the water pump housing to the exhaust housing.

Water supplied to the exhaust housing provides all cooling water to the cylinder block.

## Water Supply Tube

### 3-CYLINDER MODELS

The water pump outlet connects with the water supply tube located in the outboard's midsection. Grommets seal the water tube to the water pump housing and the adaptor housing. The water tube fastens to the base of the adapter housing with a retainer plate and screws.

Water supplied to the water tube provides all cooling water to the adapter housing and cylinder block.

## Adapter/Inner Exhaust Housing

### 3-CYLINDER MODELS

- Adapts the cylinder/crankcase assembly (powerhead) to the exhaust housing and the water tube.
- Provides water passages which route incoming and outgoing cooling water.
- Provides exhaust passages which connect to the gearcase.

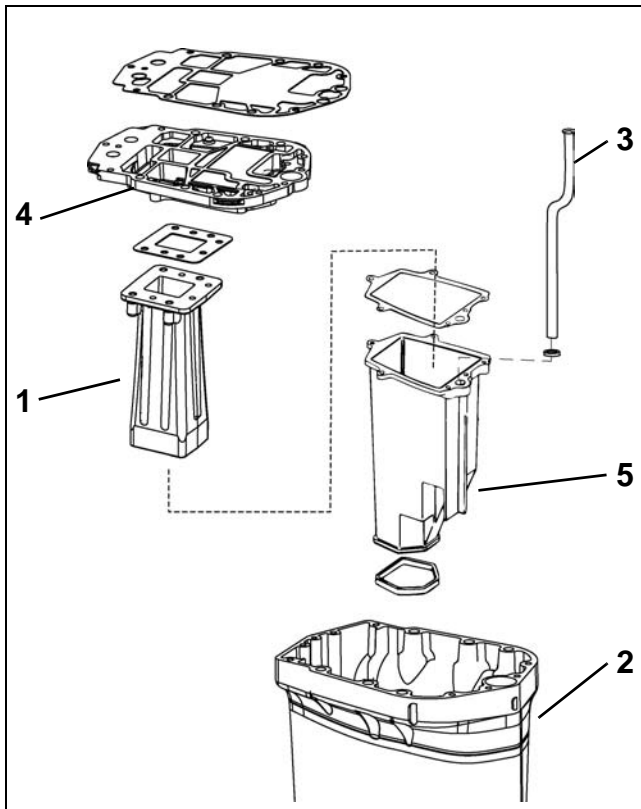

1. Megaphone
2. Exhaust housing
3. Water tube
4. Adapter housing
5. Inner exhaust housing

002436

## Pressure Relief Valve

A pressure relief valve is used to control water flow and operating temperature at higher speeds (above approximately 1800 RPM). The pressure relief valve opens as water pressure increases. Spring tension sets the opening pressure.

**Overheating:** A restricted or faulty valve typically results in HIGH SPEED overheating.

**Overcooling:** Debris may prevent the valve from closing completely.

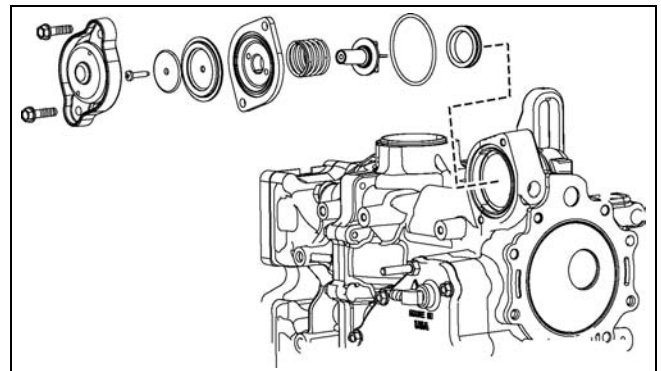

Pressure relief valve components

002437

## Thermostat

The thermostat controls water flow and operating temperature at lower speeds (below 1800 RPM).

**Overheating:** A restricted or faulty thermostat typically results in LOW SPEED overheating.

**Overcooling:** Debris may prevent the thermostat from closing completely.

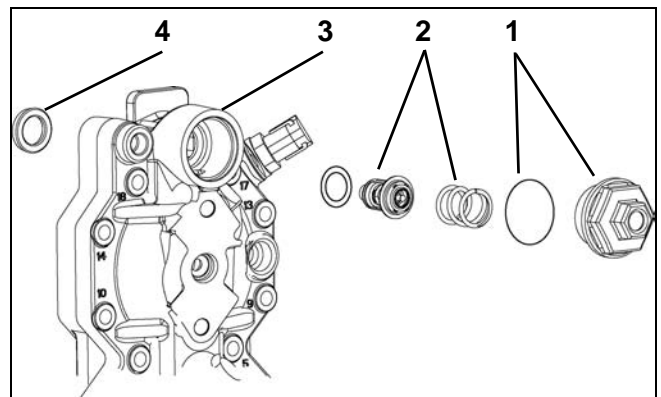

1. Cover and O-ring
2. Spring and thermostat
3. Cylinder head
4. Cylinder head seal

002439

## COOLING SYSTEM COMPONENTS

### Block Venting

A fitting and hose connected to the top of the exhaust cover allows the constant movement of water and/or air from the block. Circulated water flows through the *EMM* and vapor separator before exiting through the overboard indicator.

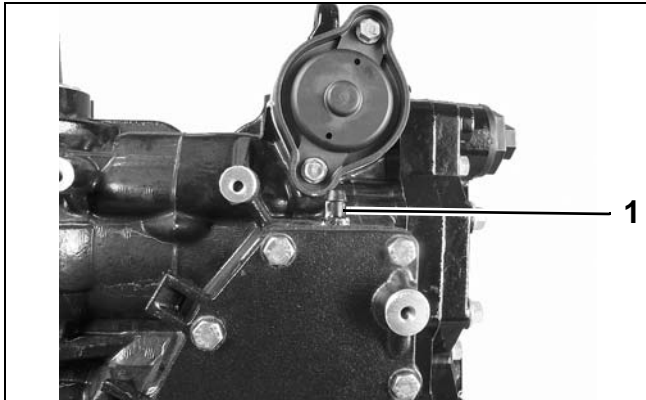

2-Cylinder models  
1. Fitting

002478

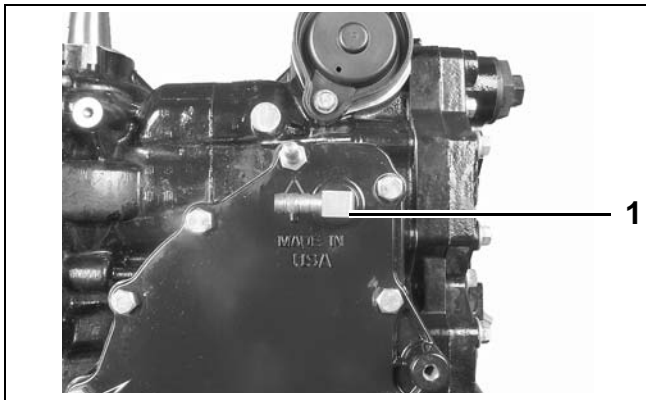

3-Cylinder models  
1. Fitting

002440

### Water Pressure Connection

A fitting and hose for an accessory water pressure gauge can be connected at the top of the cylinder block next to the pressure valve housing.

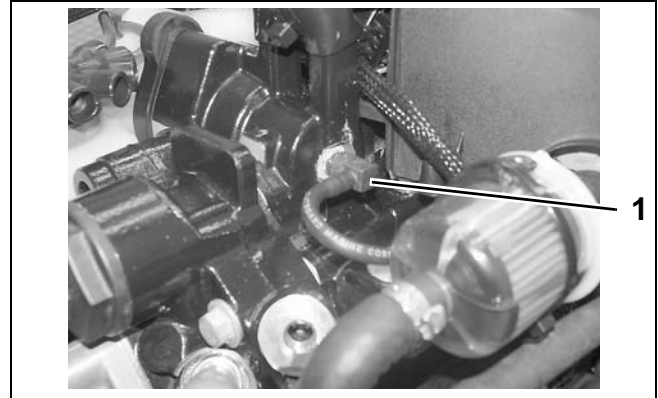

1. Fitting

002461

## OPERATION

All models use a two-stage cooling system design. The cooling system is dependent on water pump pressure and controlled by thermostat and pressure valve operation.

**NOTICE** Restricted or inadequate water flow through the outboard reduces cooling system performance and may lead to severe power-head damage.

### Cylinder Block / Cylinder Head Cooling

The flow of water through the cylinder block and cylinder head is controlled by a thermostat and a pressure relief valve. The pressure valve is located in the top of the block next to the exhaust cover.

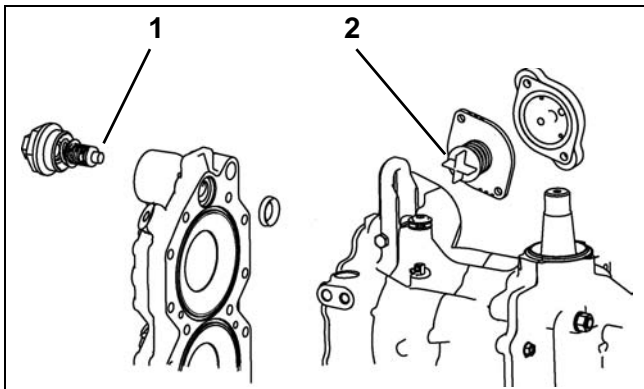

1. Thermostat  
2. Pressure valve assembly

002441

The thermostat and pressure valve control the flow of water entering the vertical water passages of the cylinder head.

**At low speed**, the pressure valve is against the seat and the thermostat is closed. Warm water from the cylinder block gradually migrates to the thermostat pocket at the top of the cylinder head.

The thermostat opens when the water temperature reaches approximately 143°F (62°C).

When the thermostat opens, water flows down through the cylinder head to a passage in the cylinder block. Water flows through the block to the exhaust housing and then out of the outboard.

**At higher speeds**, water pressure opens the pressure relief valve at approximately 1800 RPM. Water flows through the valve to the cylinder head and bypasses the thermostat. All water flows through the cylinder head to the outlet passage of the block and then exits through the exhaust housing.

### EMM and Vapor Separator Cooling

Cooling water is routed from the top of the cylinder block to the inlet fitting of the *EMM* water cavity. Cooling of the *EMM* helps to stabilize the temperatures of internal components.

**IMPORTANT:** Improper *EMM* cooling will activate service codes 25 and 29 and the Engine Monitor warning system. Refer to the **EMM Service Code Chart** at the back of this manual for specific service code information.

Cooling water from the *EMM* is routed to the water inlet fitting of the vapor separator water cavity. Cooling the vapor separator fuel chamber minimizes fuel vaporization.

Cooling water from the vapor separator is routed to the overboard indicator.

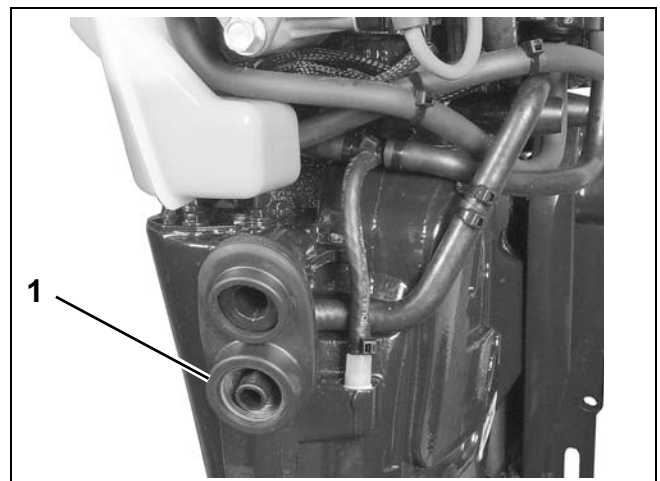

1. Overboard indicator

004969

# ENGINE TEMPERATURE CHECK

**IMPORTANT:** The engine temperatures listed below are based on an intake water temperature of 70° ± 10°F (21° ± 3°C).

Install correct test propeller and place outboard in a test tank or in the water. Start outboard and run at 3000 RPM in FORWARD gear for at least five minutes. Remember, running outboards at high speeds in test tanks may disrupt water flow to gearcase water intakes. Make sure the outboard has adequate water flow.

**⚠ CAUTION**

**When servicing the propeller, always shift the outboard to NEUTRAL, turn the key switch OFF, and twist and remove all spark plug leads so the engine cannot be started accidentally.**

Reduce speed to IDLE for five minutes. Check IDLE operating temperature.

Increase speed to 5000 RPM and check temperature.

If engine temperatures are not within range, troubleshoot cooling system.

If engine temperature tests within range, but the engine monitor display indicates a “WATER TEMP” warning, refer to **WATER TEMP/ HOT Circuit Test** on p. 108.

## Software Method

Use *Evinrude Diagnostics* software to read temperature displays.

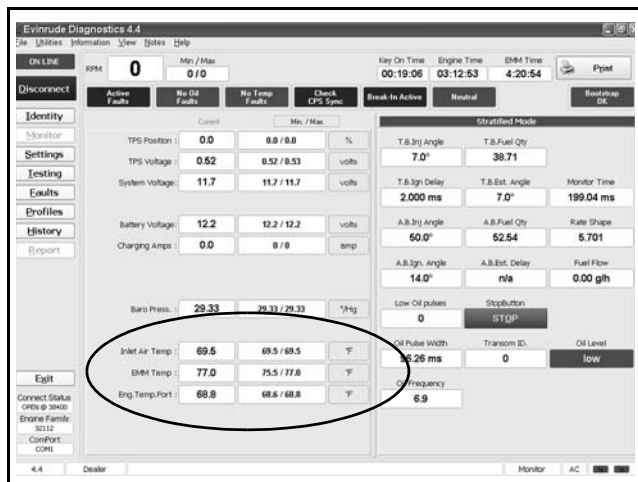

Monitor Screen 008080

Typical temperature sensor readings at IDLE speed should be 155°F ± 5°F (68.3°C ± 3°C).

Typical temperature sensor readings at WOT speed should be 160°F ± 40°F (71°C ± 22°C).

Operating temperature must not exceed 212°F (100°C).

## Pyrometer Method

Use a Temperature Gun, P/N 772018, or a digital pyrometer to measure the outboard’s operating temperatures.

Measure temperature of the thermostat housing at the top of cylinder head.

Typical pyrometer readings at IDLE speed should be 145°F ± 10°F (63°C ± 6°C).

Typical pyrometer readings at WOT speed should be 150°F ± 40°F (66°C ± 22°C).



**IMPORTANT:** If you get low or inaccurate readings with a digital pyrometer, coat the probe location with *Thermal Joint Compound*, P/N 322170.

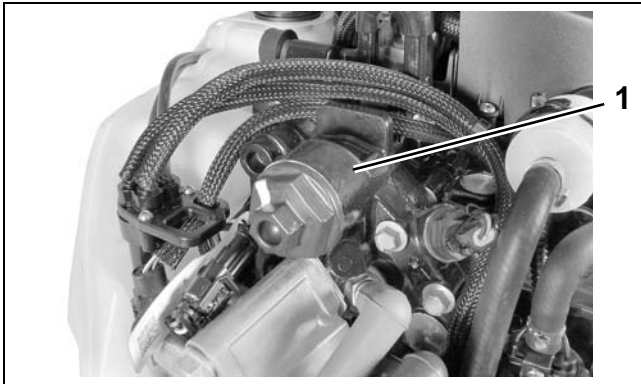

Thermostat housing

008345

**IMPORTANT:** Digital pyrometer or temperature gun measurements may be slightly lower than software temperature readings.

### Idle Operating Temperature Troubleshooting (Below Range)

If engine IDLE temperature is below operating range, 155°F ± 5°F (68.3°C ± 3°C), check thermostat and pressure relief valve operation.

#### Thermostat Inspection

Check position of thermostat seal and how thermostat seals against cylinder head. Seal must be properly fitted to flange of thermostat.

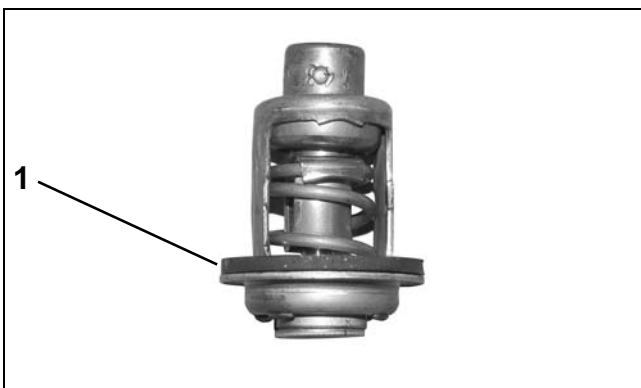

1. Thermostat seal

006401

Check thermostat for cracks, heat damage, or signs of corrosion. Check for proper operation. Thermostat opens at 143°F (62°C).

Refer to **THERMOSTAT SERVICING** on p. 182.

#### Pressure Relief Valve Inspection

The pressure relief valve should be closed at IDLE speed. Water should not flow past the plunger and seal.

Start the outboard and check IDLE operating temperature.

If IDLE temperature is too low, check pressure relief valve plunger and seal for damage or debris that could prevent the valve from closing completely.

If IDLE temperature is still below operating range, replace pressure relief valve assembly and plunger seal.

To test pressure relief valve operation, monitor temperature at the thermostat housing with Temperature Gun, P/N 772018, or digital pyrometer.

Confirm normal IDLE operating temperature.

Slowly increase engine speed from IDLE, up through 2500 RPM.

Engine temperature should decrease from normal IDLE temperatures as pressure relief valve opens. Valve should open between 1800-2200 RPM.

If temperature decreases at a lower RPM, replace pressure relief valve assembly.

Refer to **PRESSURE RELIEF VALVE SERVICING** on p. 183.

## TEMPERATURE SENDER SERVICING

### Removal

Loosen sensor and remove by hand. Use care to avoid breaking threads.



008346

Clean sensor threads, sensor, and sensor cavity.

### Installation

Fill bottom of sensor cavity with 0.7 cc of *Thermal Joint Compound*, P/N 322170. Sensor cavity should be filled to 1 inch (25 mm) below the top edge of the cavity.

Install sensor. DO NOT use gasket sealing compound. SLOWLY tighten temperature sensor to a torque of 50 to 70 in. lbs. (5.6 to 8.0 N·m).

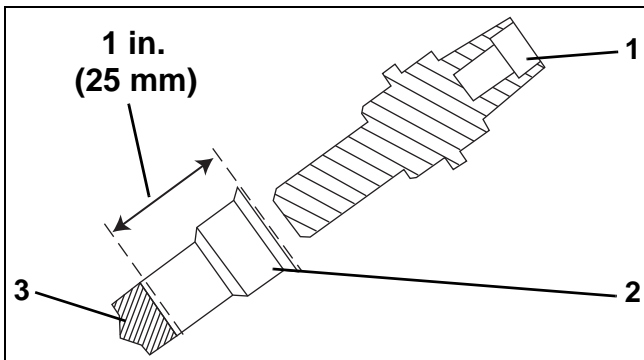

007049

1. Temperature sensor
2. Sensor cavity
3. Thermal joint compound

Wait 10 minutes for trapped air to bleed from cavity. Thermal compound may seep past threads. Retighten sensor.

## THERMOSTAT SERVICING

### Disassembly

Remove the thermostat cover and O-ring from cylinder head.

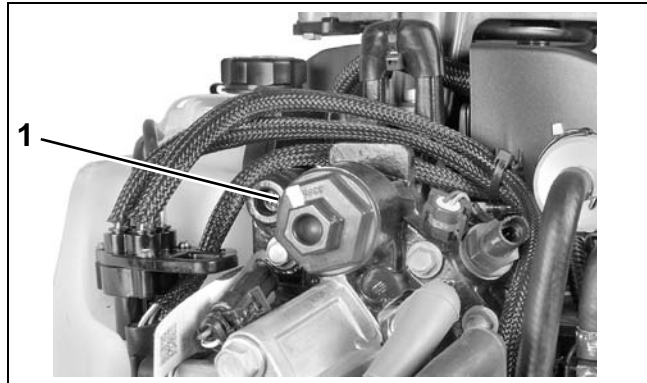

008347

Remove spring, thermostat, and gasket.

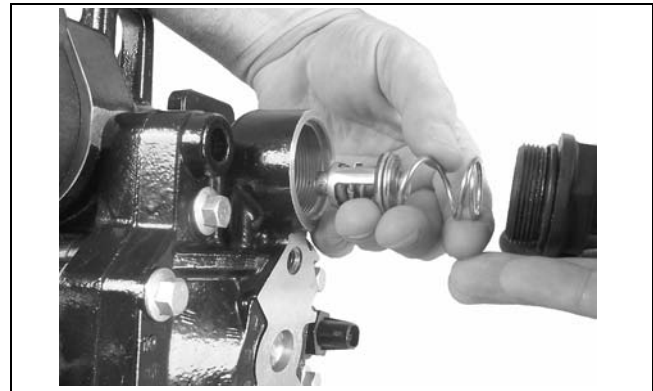

002444

Remove the cylinder head if cylinder head thermostat seal requires replacement. Place new seal in the cylinder head with side marked "TO CYL"

HEAD" facing thermostat. Refer to **Cylinder Head Installation** on p. 207.

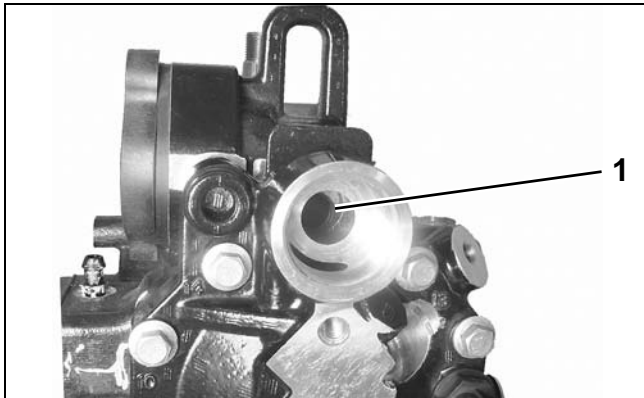

1. Cylinder head seal

002445

## Inspection

Inspect all parts for cracks, heat damage, or signs of corrosion. Replace damaged parts. Clean debris from housing and parts.



000756

## Assembly

Assembly is the reverse of disassembly. Pay close attention when performing the following **additional** tasks.

Coat threads of thermostat cover with *Gasket Sealing Compound* and install new O-ring. Install and tighten cover to a torque of 120 to 144 in. lbs. (13.5 to 16 N·m).

# PRESSURE RELIEF VALVE SERVICING

The pressure relief valve assembly should be serviced at the same time as the thermostat.

## Disassembly

Remove screws and cover from pressure valve assembly.

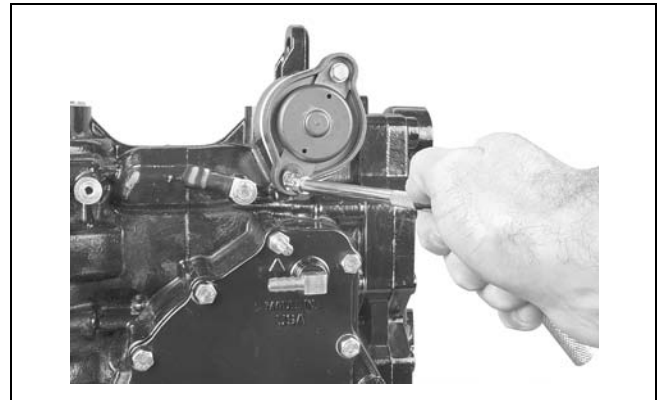

002443

Remove the pressure relief valve assembly.

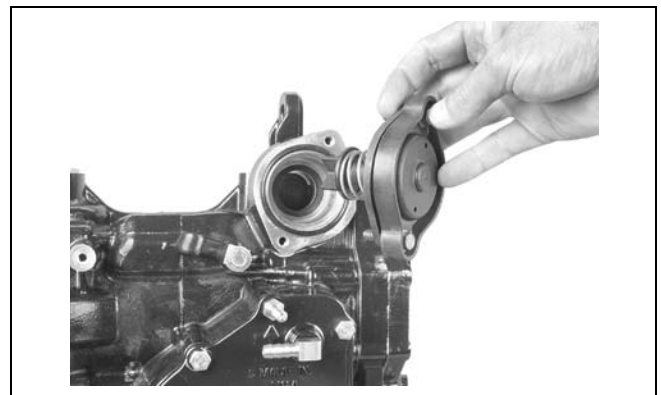

002459

---

## COOLING SYSTEM

### PRESSURE RELIEF VALVE SERVICING

---

#### Inspection

Inspect all parts for cracks, heat damage, or signs of corrosion. Replace damaged parts. Clean debris from housing and parts.

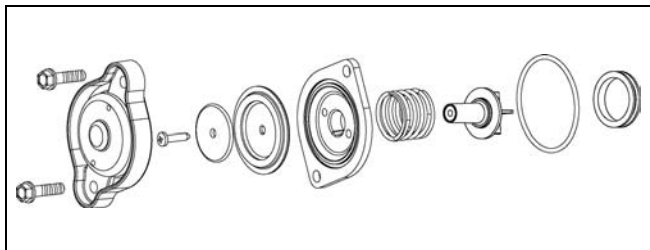

Pressure Relief Valve Assembly Components

002442

#### Assembly

Assembly is the reverse of disassembly. Pay close attention when performing the following **additional** tasks.

Install a **new** plunger seal squarely over ridge in housing.

Apply a light coat of *Triple-Guard* grease to a **new** cover o-ring and place in groove in housing.

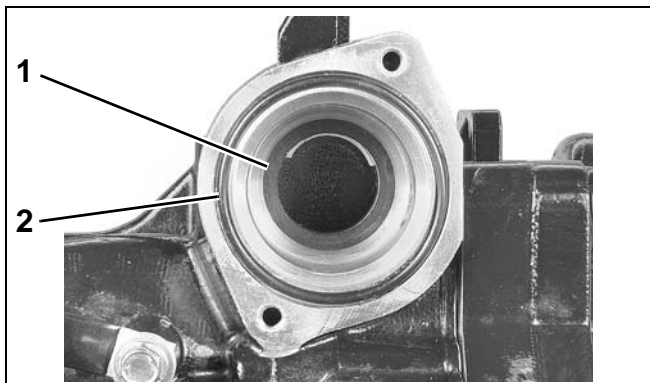

1. Plunger seal
2. Cover o-ring

002458

Install valve assembly into housing.

Tighten cover screws to a torque of 60 to 84 in. lbs. (7 to 9.5 N·m).

# POWERHEAD

## TABLE OF CONTENTS

SERVICE CHART .....	186
COMPRESSION TESTING .....	190
POWERHEAD REMOVAL .....	190
2-CYLINDER MODELS .....	190
3-CYLINDER MODELS .....	192
POWERHEAD DISASSEMBLY .....	193
SYSTEMS REMOVAL .....	193
THROTTLE LINKAGE REMOVAL .....	194
SHIFT LINKAGE REMOVAL .....	194
CRANKCASE DISASSEMBLY .....	195
CYLINDER HEAD REMOVAL .....	196
CONNECTING RODS AND PISTONS .....	196
CRANKSHAFT REMOVAL .....	197
CYLINDER BLOCK CLEANING .....	200
POWERHEAD INSPECTION .....	201
POWERHEAD ASSEMBLY .....	203
CRANKSHAFT ASSEMBLY .....	203
PISTONS AND CONNECTING RODS .....	205
CYLINDER HEAD INSTALLATION .....	207
CRANKSHAFT AND CONNECTING ROD INSTALLATION .....	208
CRANKCASE ASSEMBLY .....	211
SHIFT LINKAGE INSTALLATION .....	212
THROTTLE LINKAGE INSTALLATION .....	213
FINAL POWERHEAD ASSEMBLY .....	214
UPPER MOUNT SERVICING (3-CYLINDER) .....	215
POWERHEAD INSTALLATION .....	216
POWERHEAD MOUNTING – 2-CYLINDER MODELS .....	216
POWERHEAD MOUNTING – 3-CYLINDER MODELS .....	218
SHIFT LINKAGE ADJUSTMENT .....	220
FINAL ADJUSTMENTS .....	220
POWERHEAD VIEWS .....	221
2-CYLINDER MODELS .....	221
3-CYLINDER MODELS .....	228

**POWERHEAD  
SERVICE CHART**

**SERVICE CHART**

**2-CYLINDER MODELS**

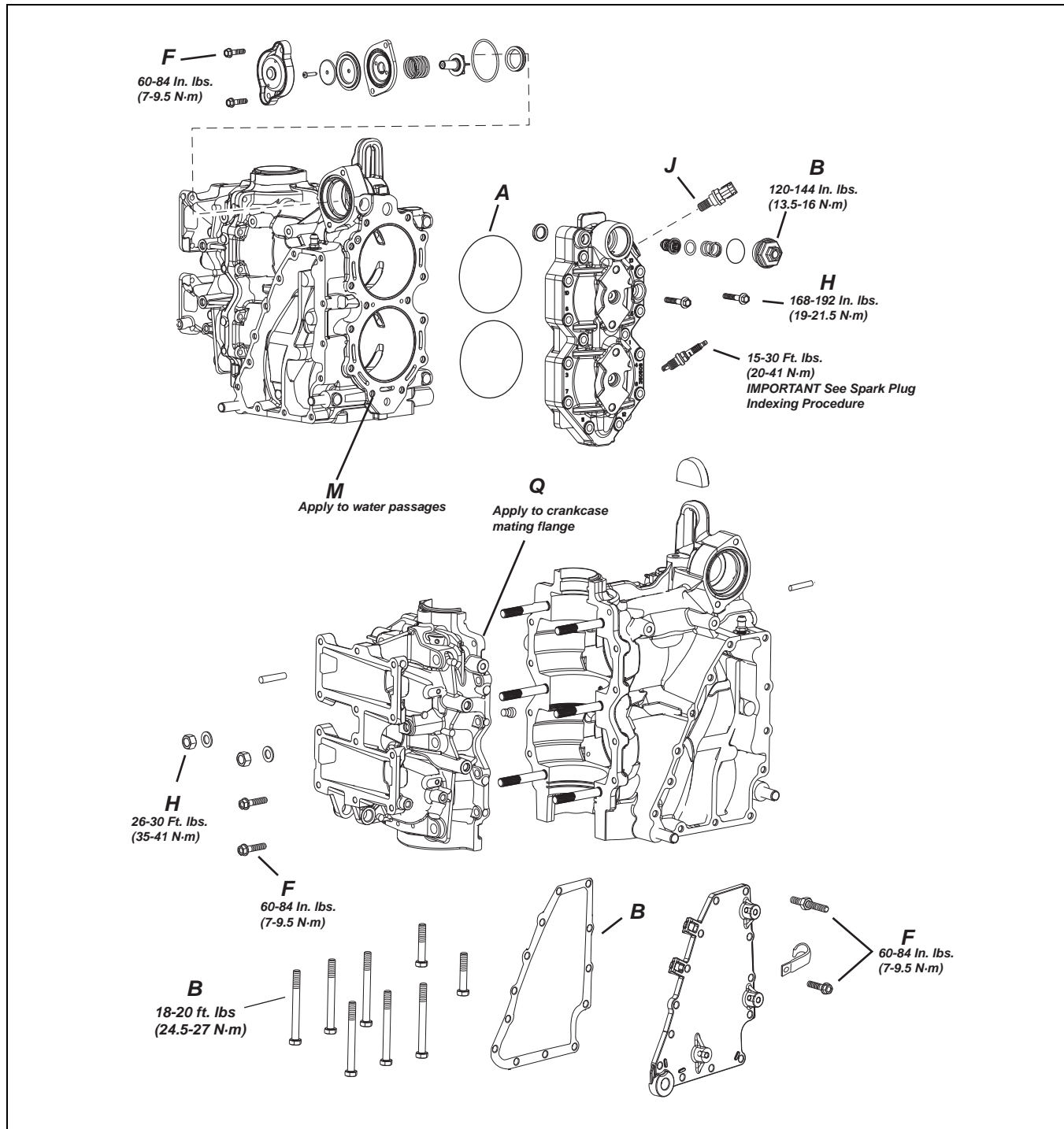

<b>A</b> Triple-Guard Grease	<b>F</b> Blue Nut Lock	<b>M</b> RTV Sealant
<b>B</b> Gasket Sealing Compound	<b>G</b> Needle Bearing Grease	<b>P</b> Permatex No. 2
<b>D</b> Moly Lube	<b>H</b> Outboard Lubricant	<b>Q</b> Gel Seal II
<b>E</b> Red Ultra Lock	<b>J</b> Thermal Grease	<b>Y</b> Extreme Pressure Grease

002283

**2-CYLINDER MODELS**

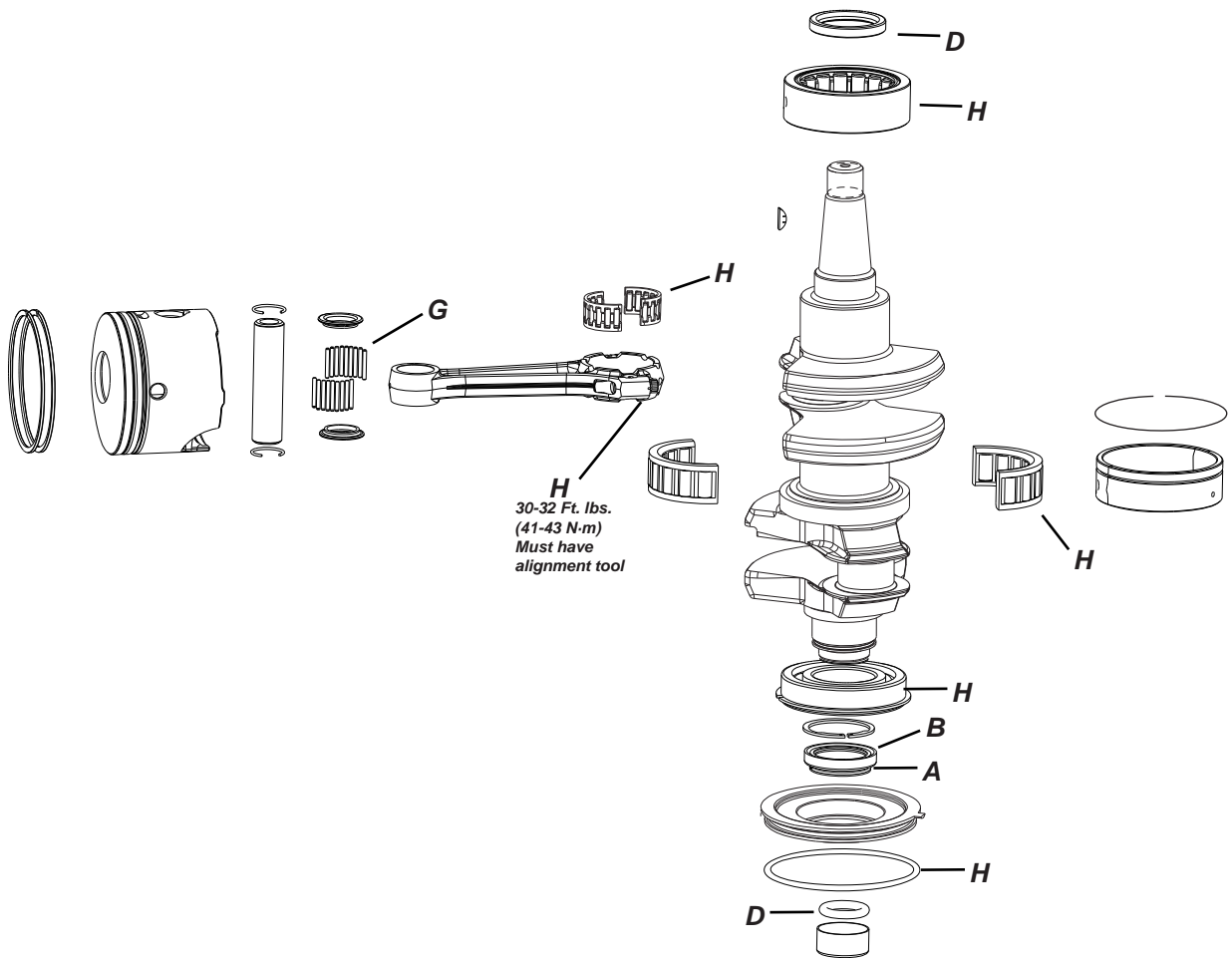

**H**  
30-32 Ft. lbs.  
(41-43 N-m)  
Must have  
alignment tool

- A** Triple-Guard Grease
- B** Gasket Sealing Compound
- D** Moly Lube
- E** Red Ultra Lock
- F** Blue Nut Lock
- G** Needle Bearing Grease
- H** Outboard Lubricant
- P** Permatex No. 2
- Q** Gel Seal II
- Y** Extreme Pressure Grease

UU2284

# POWERHEAD SERVICE CHART

## 3-CYLINDER MODELS

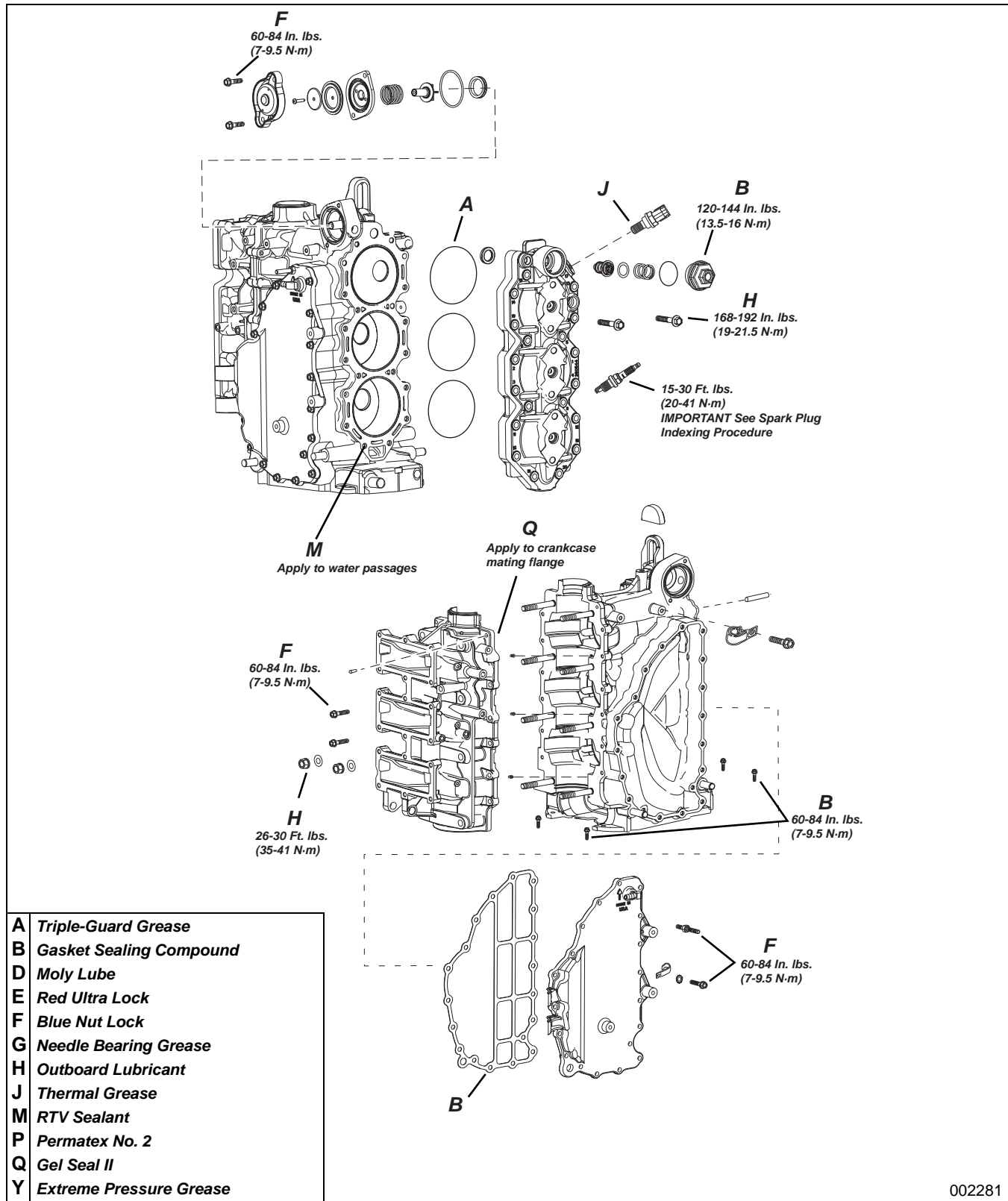



**3-CYLINDER MODELS**

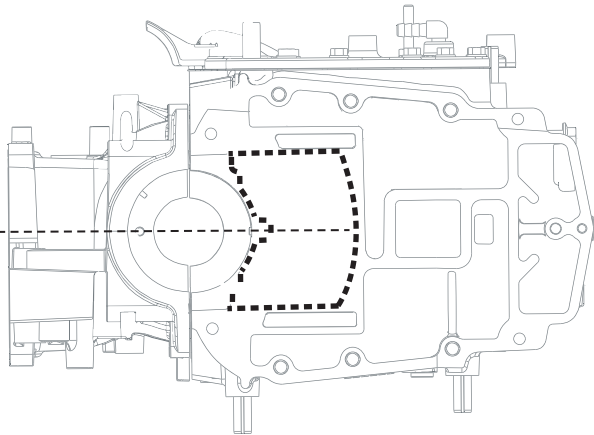
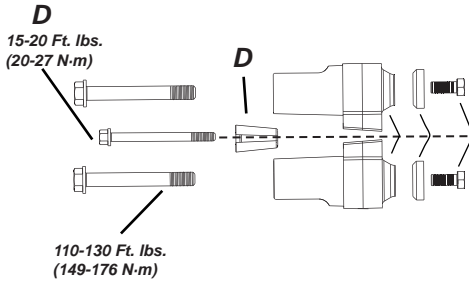
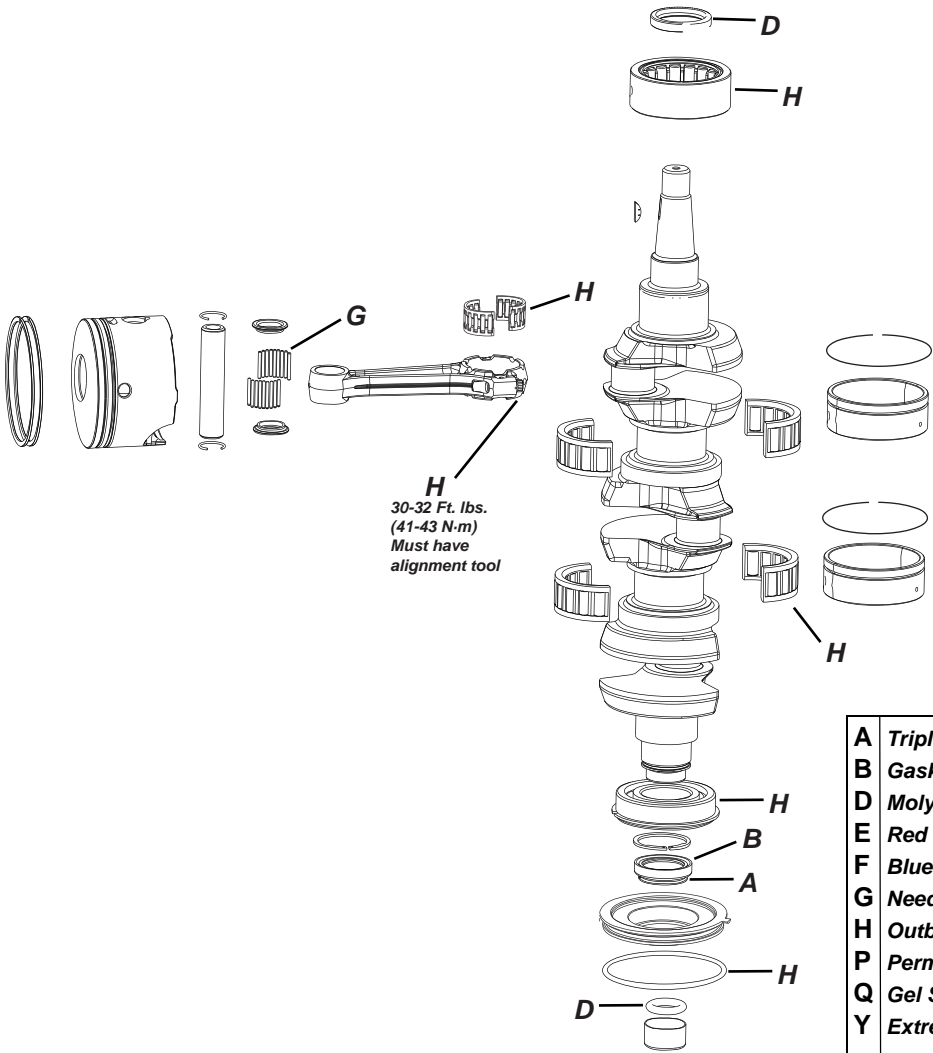

UU2282

## POWERHEAD COMPRESSION TESTING

### COMPRESSION TESTING

Start and run outboard until it achieves operating temperature, then shut OFF.

Disconnect crankshaft position sensor (CPS) connector. Remove all spark plugs.

Advance throttle linkage to WOT.

Install compression tester's hose attachment into spark plug hole (14 mm threads).

While cranking outboard with starter, note maximum pressure reading on gauge. Repeat procedure for each cylinder.

If engine shows a variation greater than 15 psi (100 kPa) between cylinders, check for:

- damaged cylinder head
- damaged pistons
- broken or stuck piston rings
- scored cylinder walls

Return throttle to idle position and reconnect CPS connector. Replace spark plugs. Refer to Spark Plug **Indexing** on p. 42.

### POWERHEAD REMOVAL

#### 2-Cylinder Models

#### WARNING

**Protect against hazardous fuel spray. Before starting any fuel system service, carefully relieve fuel system pressure. Refer to Relieving Fuel System Pressure on p. 142.**

**To prevent accidental starting while servicing, twist and remove spark plug leads.**

Remove lower motor covers. Refer to **Lower Cover Removal** on p. 50.

Disconnect power trim connectors and exhaust water valve electrical connector (60, 65).

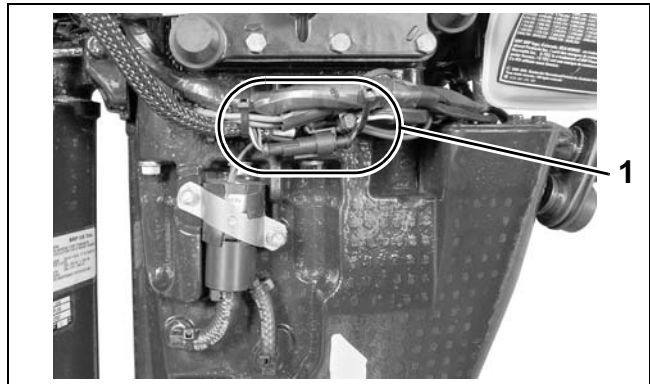

1. Connectors

008429

Disconnect cooling water hoses from exhaust housing.

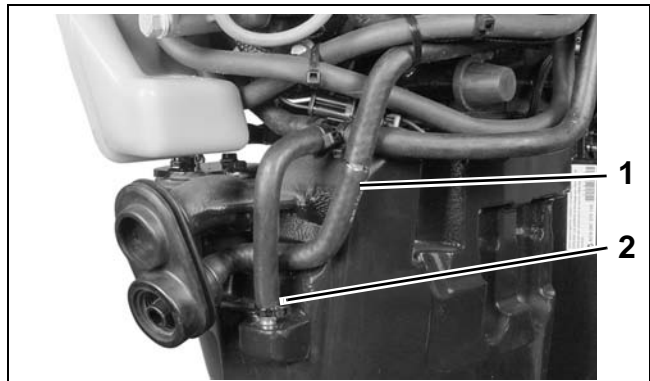

1. Overboard indicator hose  
2. Drain hose

004298

Remove pin and washer from shift rod lever to release the lower shift rod.

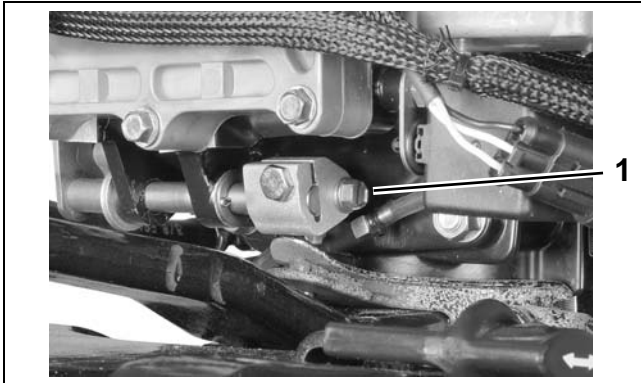

1. Shift rod screw 002171

**ROPE START MODELS**

Remove throttle cable and tiller shift rod.

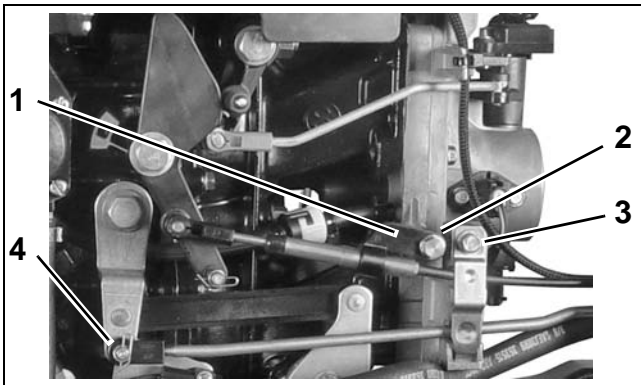

1. Cable anchor  
2. Anchor screw  
3. Cable retainer  
4. Shift rod retainer 006526m

Remove the recoil starter housing and starter ratchet. Refer to **RECOIL STARTER REMOVAL** on p. 363.

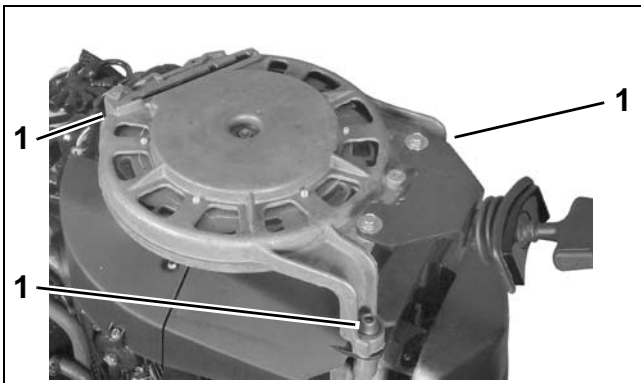

1. Starter housing screws (3) 002515

**ALL MODELS**

Install Lifting Fixture, P/N 396748, on flywheel and seat the three screws completely.

**NOTICE** Be sure to use only the 1 1/8 in. (short) screws, P/N 398067, included with the tool to avoid damage to electronic components under the flywheel.

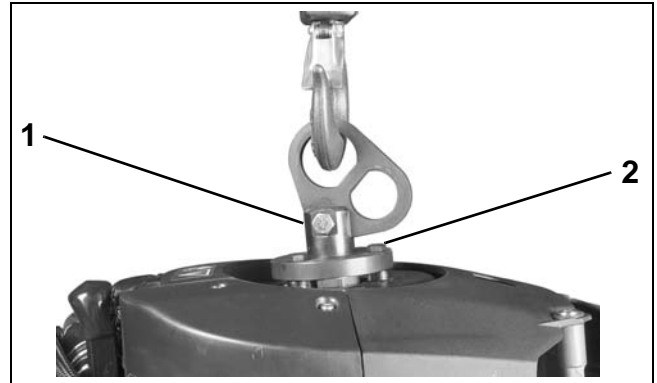

1. Lifting fixture 002098  
2. 1 1/8 in. screws

Fasten appropriate chain hook to eye of tool and support weight of powerhead with hoist.

Loosen the screws holding the exhaust water valve to the exhaust housing.

Move water valve aside and remove the eight exhaust housing to powerhead screws.

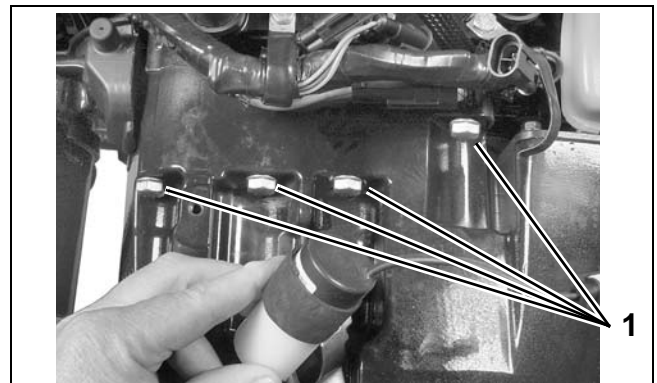

1. Powerhead screws 004292

Use a suitable tool to carefully separate the powerhead from exhaust housing.

**IMPORTANT:** Do not damage the powerhead or exhaust housing mating surfaces.

# POWERHEAD

## POWERHEAD REMOVAL

### 3-Cylinder Models

#### WARNING

Protect against hazardous fuel spray. Before starting any fuel system service, carefully relieve fuel system pressure. Refer to Relieving Fuel System Pressure on p. 142.

To prevent accidental starting while servicing, twist and remove spark plug leads.

Remove lower motor covers. Refer to **Lower Cover Removal** on p. 50.

Disconnect power trim connectors.

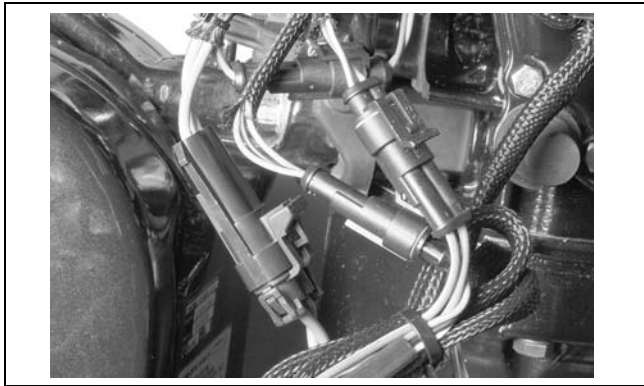

002152

Remove pin and washer from shift rod lever to release the lower shift rod.

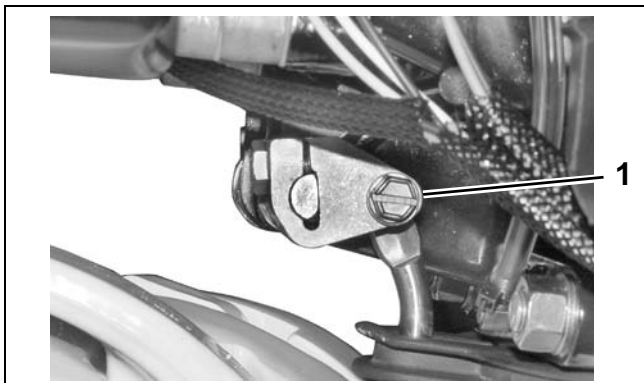

1. Shift rod pin

002013

Remove six retaining screws and exhaust relief muffler.

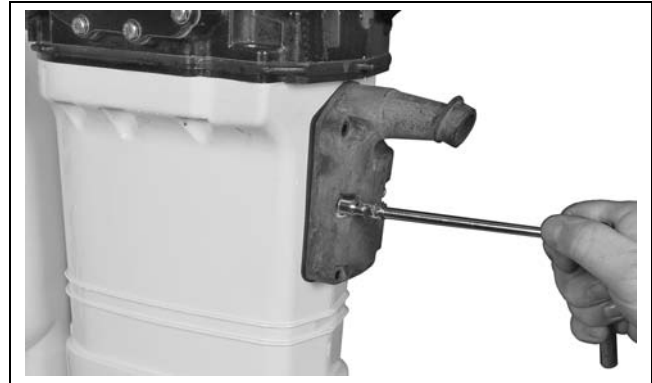

002159

Install Lifting Fixture, P/N 396748, on flywheel and seat the three screws completely.

**NOTICE** Be sure to use only the 1 1/8 in. (short) screws, P/N 398067, included with the tool to avoid damage to electronic components under the flywheel.

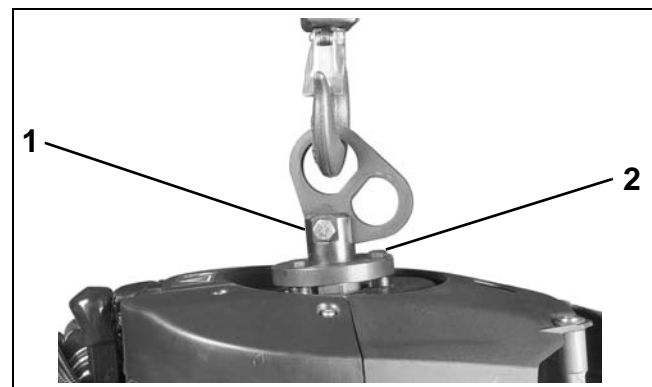

1. Lifting fixture  
2. 1 1/8 in. screws

002098

Fasten appropriate chain hook to eye of tool and support weight of powerhead with hoist.

Remove the small powerhead screw at rear.

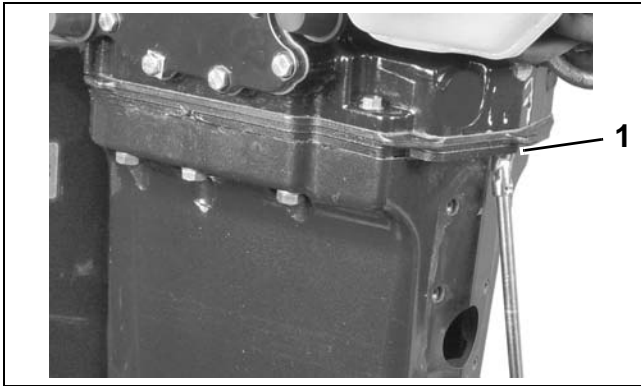

1. Rear small powerhead screw 002160

Remove remaining four small powerhead screws, six large powerhead screws, and the upper mount screws.

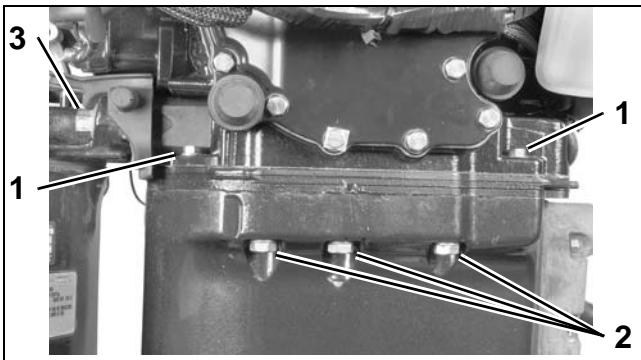

1. Small powerhead screws 002153  
2. Large powerhead screws  
3. Upper mount screws

Use a suitable tool to carefully separate the powerhead from exhaust housing.



002161

**IMPORTANT:** Do not damage the powerhead or exhaust housing mating surfaces.

## POWERHEAD DISASSEMBLY

### Systems Removal

To simplify reassembly and wiring installation, lay out the various screws and clamps in the order of their proper location.

Remove the electric starter. Refer to **Starter Removal** on p. 115.

Remove the oil tank. Refer to **Oil Tank Assembly** on p. 169.

Remove fuel pump assemblies, fuel manifolds, and filter. Refer to **FUEL COMPONENT SERVICING** on p. 142.

Remove *EMM*, then electrical harness assembly. Label connectors for reassembly locations. Refer to **EMM SERVICING** on p. 70.

Remove flywheel and stator. Refer to **FLYWHEEL AND STATOR SERVICING** on p. 110.

Remove ignition coils and fuel injectors. Refer to **IGNITION COIL SERVICING** on p. 112 and **Fuel Injector Service** on p. 146.

**IMPORTANT:** Mark injectors for cylinder location before removal. All injectors must be installed in their original location. Improper injector installation can result in powerhead failure.

Remove all oil distribution and recirculation hoses.

Remove throttle linkage. Refer to **Throttle Linkage Removal** on p. 194.

Remove shift linkage. Refer to **Shift Linkage Removal** on p. 194.

Remove the throttle body and reed plate assemblies. Refer to **Intake Manifold Service** on p. 149.

Remove pressure valve assembly. Refer to **PRESSURE RELIEF VALVE SERVICING** on p. 183.

# POWERHEAD

## POWERHEAD DISASSEMBLY

### Throttle Linkage Removal

Remove throttle cam and throttle lever.

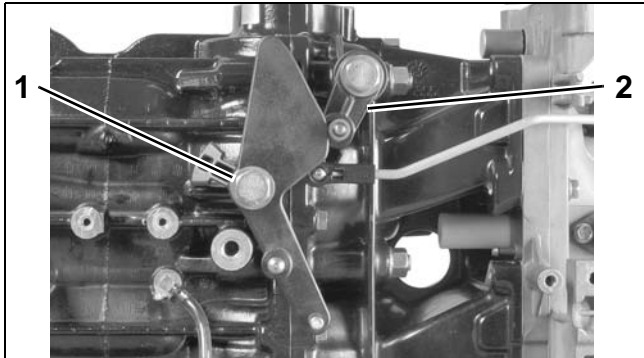

**2-Cylinder Models**  
1. Throttle lever screw  
2. Throttle return lever

002245

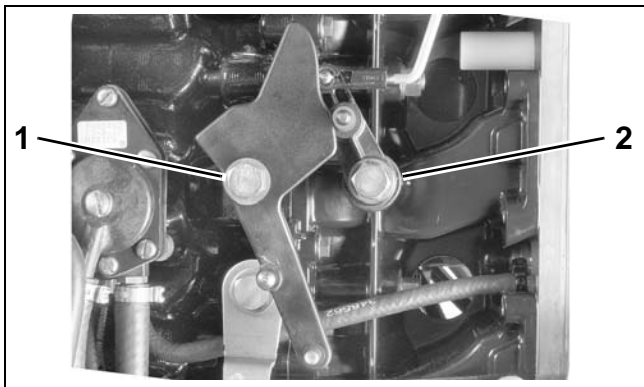

**3-Cylinder Models**  
1. Throttle cam screw  
2. Throttle lever screw

002257

### Shift Linkage Removal

Remove shoulder screw from shift arm and retaining screw from shift rod lever.

Remove the cotter pin and washer holding the shift shaft (2-cylinder models).

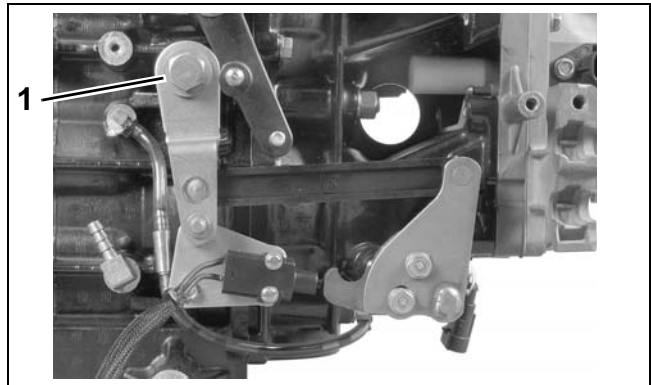

1. Shift lever screw

002250



1. Shift rod lever screw  
2. Cotter pin

002246

Slide entire shift linkage assembly from crankcase.

Remove the ball, guide, and spring of the shift detent assembly from the crankcase.

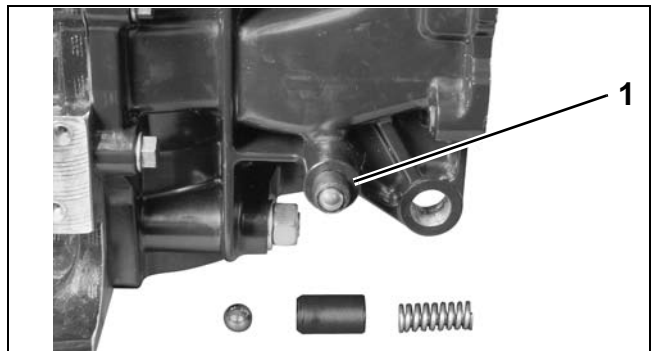

1. Shift detent assembly

002135

## Crankcase Disassembly

Remove screws and carefully pry off exhaust side water cover.

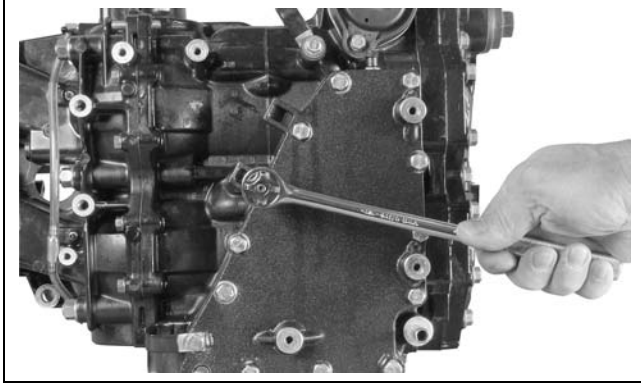

002234

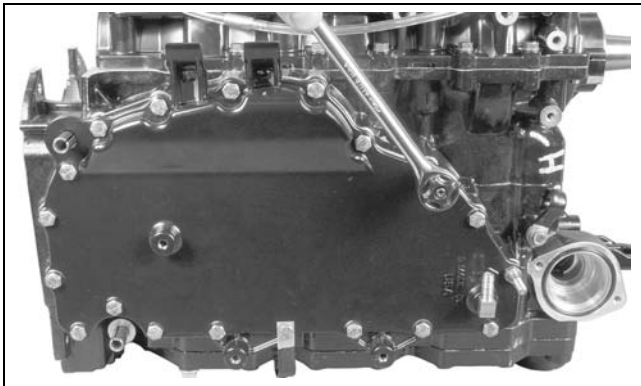

002124

**⚠ WARNING**

**Wear safety glasses to avoid injury.**

Use a 1/8 in. diameter pin punch to push crankcase taper pin toward the front side of the engine.

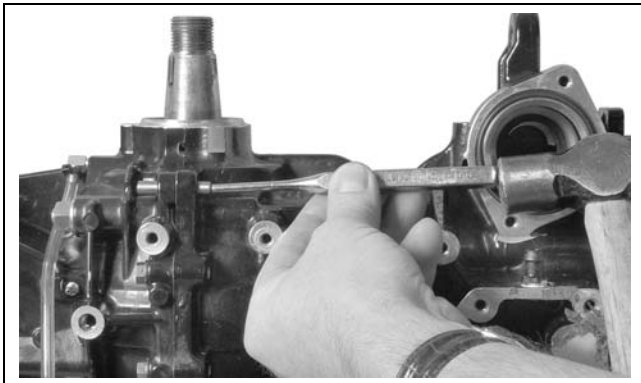

002232

**IMPORTANT:** Do not use a tapered punch or any other tool that could jam in or damage the taper bore when removing the pin.

Remove crankcase flange screws.

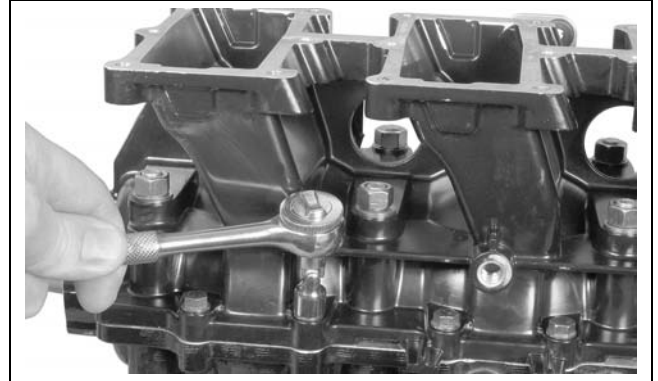

002137

Loosen in stages and remove the main bearing nuts and washers.

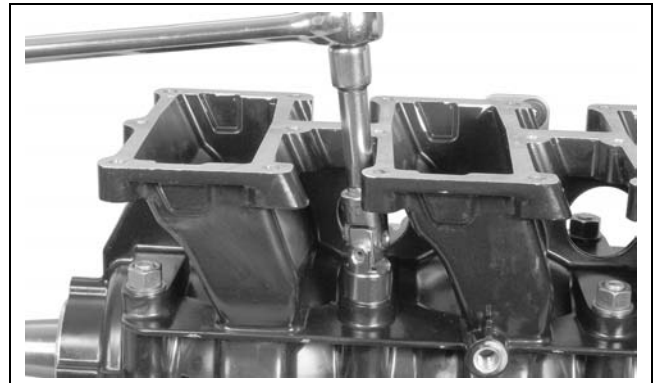

002138

Separate crankcase and cylinder block. It may be necessary to tap on crankshaft with a rawhide or rubber mallet to loosen.

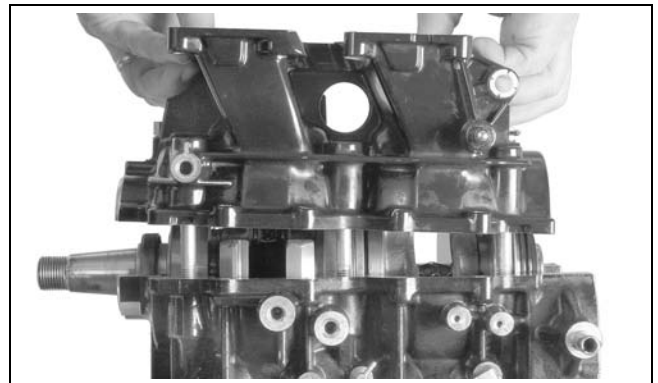

002252

## POWERHEAD POWERHEAD DISASSEMBLY

### Cylinder Head Removal

Remove thermostat cover and thermostat assembly. Refer to **THERMOSTAT SERVICING** on p. 182.

Loosen **in stages** and remove cylinder head screws. Remove the cylinder head. Discard thermostat seal and O-rings.

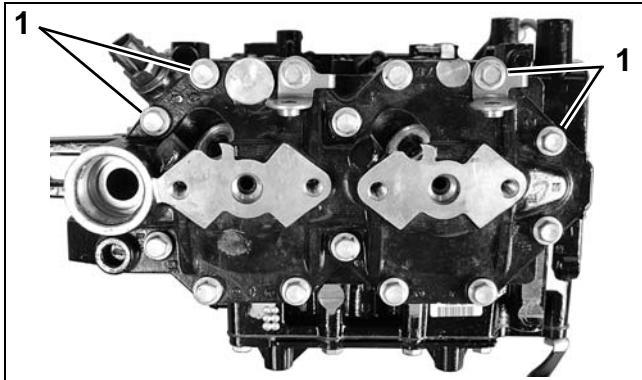

1. Cylinder head screws

007850

### Connecting Rods and Pistons

Use a permanent marker to identify each connecting rod cap, connecting rod, and piston by cylinder number. Number 1 is closest to the top.

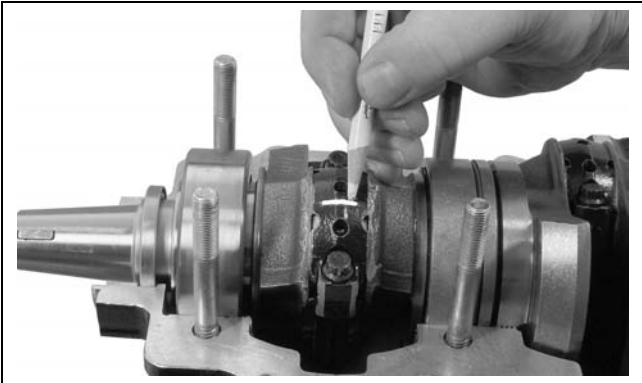

002140

Use Torquing Socket, P/N 331638, to loosen **in stages** the rod cap retaining screws. **DO NOT** remove the screws.

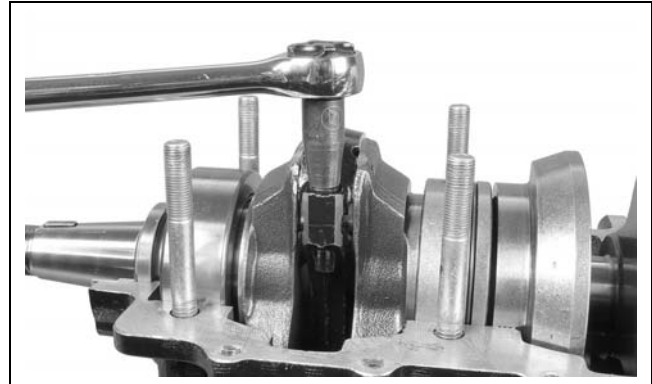

002123

Use one hand to support the piston, and remove the rod cap screws with your other hand. Remove each piston and rod assembly.



002141

**NOTICE** Reattach each rod cap to its rod as soon as the piston is removed. Each cap is unique and can only be installed on its mated rod. Do not allow rod to contact inside surface of cylinder or crankshaft.

**IMPORTANT:** Identify all internal components so that if reused, they can be reinstalled in their original positions.

Repeat steps for each remaining piston and connecting rod.



Use an appropriate ring expander to remove all piston rings from pistons. Discard the rings.

**⚠ WARNING**

**Wear safety glasses to avoid injury.**



002054

Remove wrist pin retaining rings. Discard retaining rings.



002046

The wrist pin fit is loose on both sides. Push the wrist pin through to free the piston from the con-

necting rod. If necessary, use Wrist Pin Pressing Tool, P/N 326356, to remove the wrist pin bearing.



002047

Be careful not to lose any of the 28 needle bearings or the two wrist pin washers. Do not mix bearings with those from another cylinder. If any of the bearings are worn or lost, replace all 28 bearings during reassembly.

## Crankshaft Removal

Carefully lift crankshaft straight up and remove from crankcase.

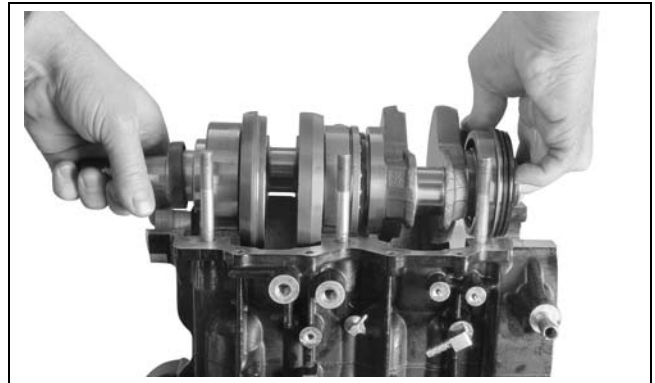

002263

Remove upper seal from crankshaft. Discard the seal. A new upper seal must be installed on assembly.

# POWERHEAD

## POWERHEAD DISASSEMBLY

Remove the upper main bearing.

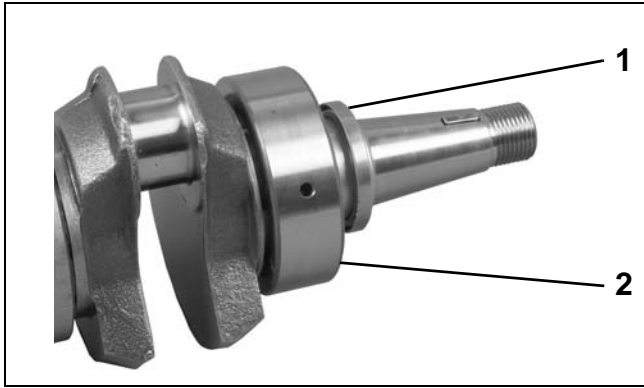

- 1. Upper oil seal
- 2. Upper main bearing

002034

Use a punch to remove the housing seal. Discard seal.

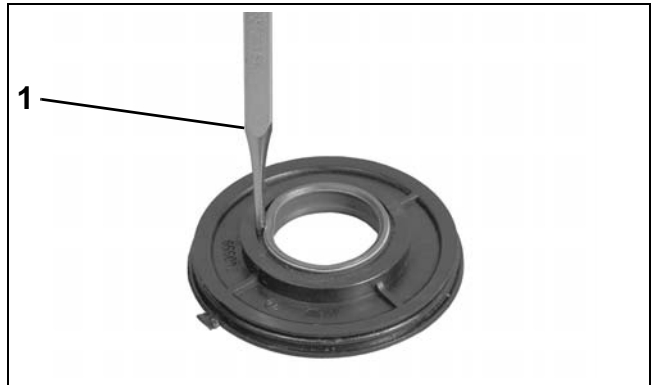

- 1. Punch

002053

Remove the lower bearing seal housing.



002042

Inspect housing and replace if necessary.

Remove the O-ring from crankshaft sleeve and inspect it. Replace the O-ring if it is not in good condition.

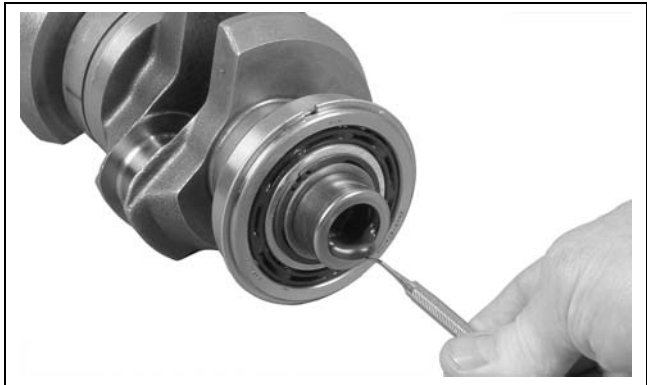

002040

Remove the housing O-ring. Discard O-ring.



002044

Inspect the crankshaft sleeve and replace if necessary. To remove the sleeve, use Slide Hammer, P/N 432128, and Large Puller Jaws, P/N 432129.

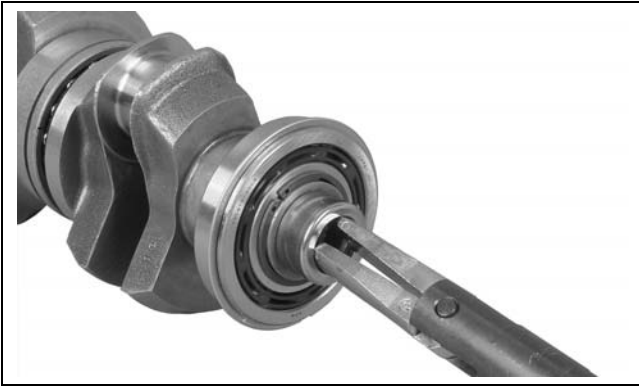

002041

Use a bearing separator to support the bearing, and press off the crankshaft.

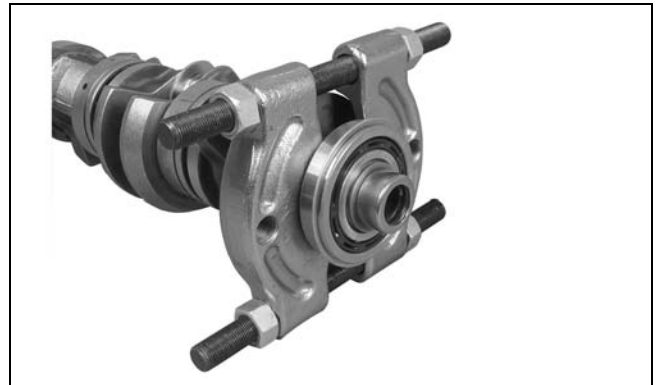

002052

Remove the lower main bearing only if it needs to be replaced. Use external retaining ring pliers to remove the lower bearing retaining ring.

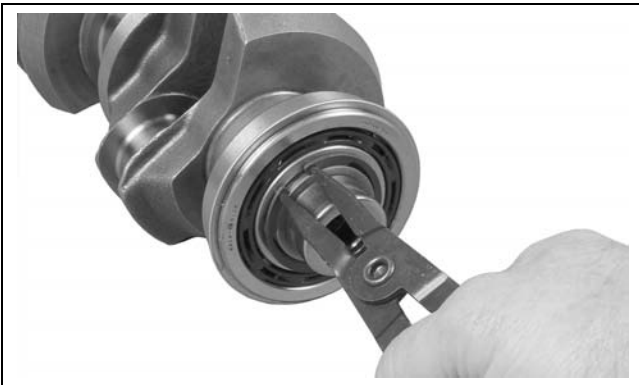

002039

Remove center main bearings and split sleeves for inspection. DO not mix parts. Note location of bearings for reassembly.



24381

**IMPORTANT:** If the lower main bearing is removed from the crankshaft, it must be discarded. DO NOT reuse it.

# CYLINDER BLOCK CLEANING

**IMPORTANT:** Before inspecting or assembling powerhead, all internal components must be completely clean and free of contaminants. Be careful to avoid damaging any machined surfaces.

Remove any carbon accumulation from exhaust port areas.

Remove any carbon accumulation from cylinder head combustion chambers.

If cylinder walls are glazed from extended use, use a rigid, medium grit cylinder hone to resurface walls. Use slow RPM for best oil retention and ring sealing. When finished, a cross hatch pattern of 22 to 32° should be visible in the cylinder wall. The pattern should be uniform in both directions.

**IMPORTANT:** To avoid piston or cylinder block damage, restore the chamfer to all port edges using a ball hone or other suitable tool.

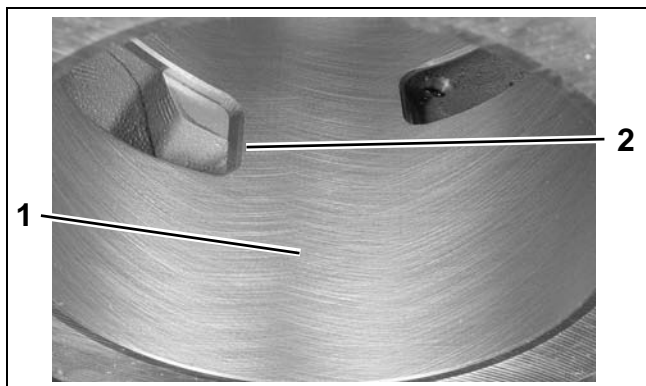

1. Crosshatch pattern in cylinder wall  
2. Chamfered port edge  
002067

Use *Gel Seal and Gasket Remover* to remove all traces of gaskets, adhesives, and *Gel-Seal II™*

sealant from the cylinder block, crankcase, cylinder head, and water cover.

**⚠ WARNING**  
**To avoid personal injury, wear eye protection and rubber gloves when using *Gel Seal and Gasket Remover*.**

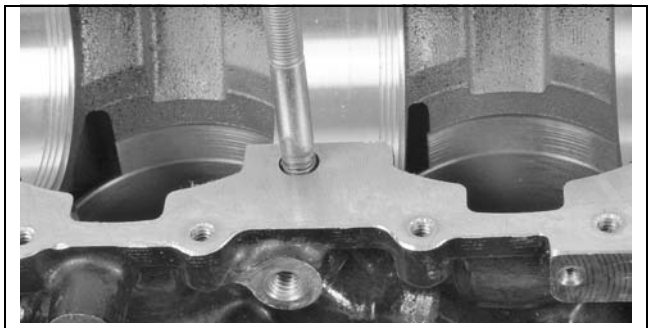

002068

Carefully remove any carbon accumulation from the tops and ring grooves of the piston using *Engine Tuner*. A ring groove cleaning tool can be made by breaking an old ring and grinding an angle on its end. Do not damage ring grooves while cleaning.

Thoroughly wash entire cylinder block and crankcase with warm, soapy water to remove all traces of contaminants.

Air dry cylinder block and crankcase. Blow all holes and passageways with compressed air.

**⚠ WARNING**  
**To avoid personal injury, wear eye protection and set compressed air pressure at less than 25 psi (172 kPa).**

Cover the cylinder walls with a liberal amount of outboard lubricant to prevent corrosion.

# POWERHEAD INSPECTION

For dimensions, refer to **SERVICE SPECIFICATIONS** on p. 10.

**IMPORTANT:** Before any inspection process can begin, all internal components must be completely clean and free of contaminants.

Visually inspect all parts. Check for unusual wear patterns, scuffing, or deterioration of aluminum parts, heat-related discoloration of bearings and bearing surfaces, and broken components.

## Cylinder Head

Check for cylinder head warpage using a piece of bar stock or machinist's straightedge and a feeler gauge set.

Cylinder head warpage must not exceed 0.006 in. (0.15 mm) per inch of measurement. Replace head if warpage exceeds this dimension.

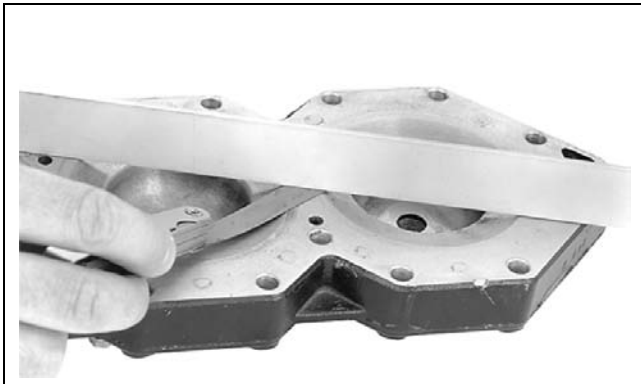

24423

Check fuel deflector pins for damage.

## Crankshaft

Measure the diameter of each crankpin and main bearing journal. The lower main bearing journal would only be measured if the bearing was removed for another reason.

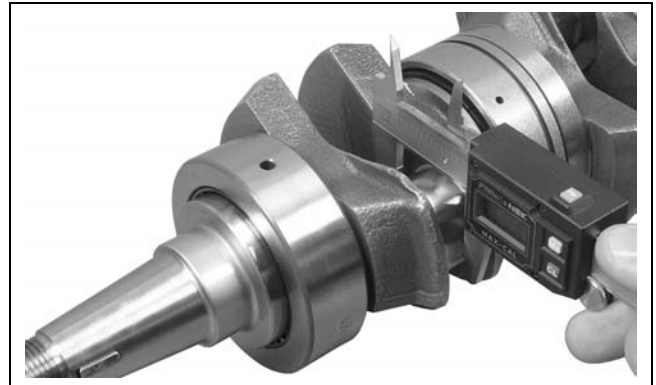

002142

## Cylinder Bore

Use a Cylinder Bore Gauge to inspect each cylinder bore for an out-of-round, oversize, or tapered condition. Be sure the gauge is perfectly square in the bore when measuring.

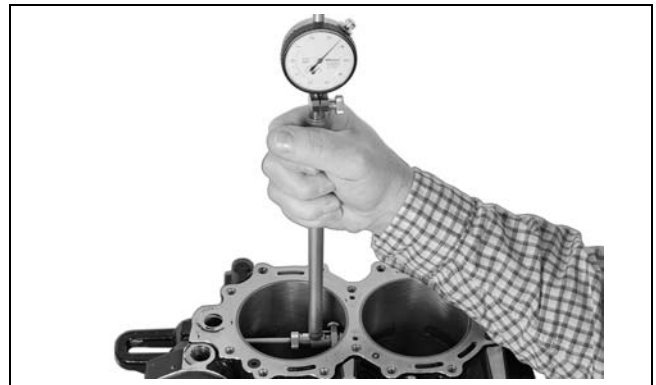

007283

Measure each cylinder in at least two areas. Each area should be measured twice. The difference between the two measurements in each area is the cylinder out-of-round dimension.

- The cylinder must not be out-of-round by more than 0.004 in. (0.10 mm).

## POWERHEAD

### POWERHEAD INSPECTION

The dimensional difference between the two areas is cylinder taper.

- The cylinder taper must not exceed 0.002 in. (0.05 mm).

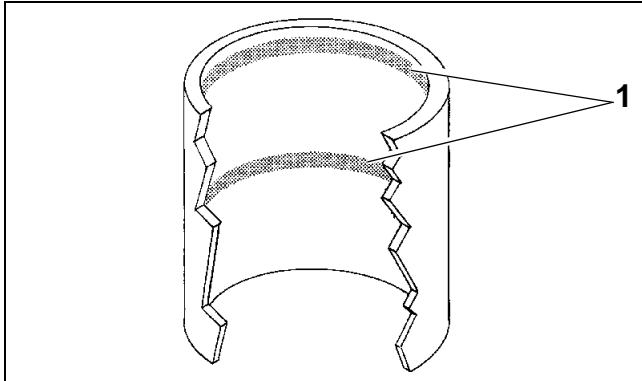

1. Measurement areas

DR3482

The difference between the measurements and standard bore is cylinder oversize. For dimensions, refer to **SERVICE SPECIFICATIONS** on p. 10.

- The cylinder must not be oversized by more than 0.003 in. (0.08 mm).

## Pistons

Visually inspect pistons for signs of abnormal wear, scuffing, cracks, or burning.

## Piston Rings

For new ring sets, place each ring separately in its respective bore. Use a piston to square the ring in the cylinder. Use a feeler gauge to measure the ring end gap.



002143

Ring end gap should be:

- 0.011 to 0.023 in. (0.28 to 0.58 mm)

**IMPORTANT:** Ring end gap increases approximately 0.003 in. (0.076 mm) for each 0.001 in. (0.025 mm) increase in cylinder bore diameter. **DO NOT** exceed cylinder oversize dimension.

Use a machinist's straightedge to check for proper ring clearance. Position piston rings on piston. Push rings into groove and hold straightedge against the side of the piston. Rings must be even or just below the surface of piston. Rings must move freely in piston ring groove.

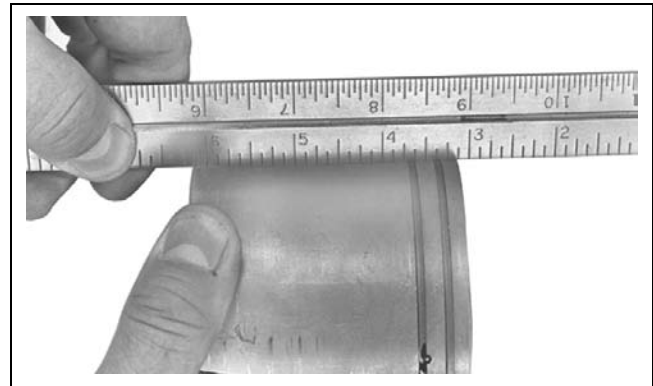

31796

## Bearings

Inspect center main bearings and split sleeves for excess wear, nicks, or scratches. Replace if necessary.

Inspect crankshaft rod bearings for excess wear, nicks, or scratches. Replace if necessary.



24381

# POWERHEAD ASSEMBLY

**IMPORTANT:** Proceed slowly. Make no forced assemblies unless a pressing operation is called for. All internal components must be perfectly clean and lightly coated with outboard lubricant.

**IMPORTANT:** Use new wrist pin retaining rings, gaskets, seals, and O-rings during assembly.

## Crankshaft Assembly

Oil the end of the crankshaft. Use Crankshaft Bearing/Sleeve Installer, P/N 338647, and place a new lower main bearing onto crankshaft with lettered side facing the tool. Install bearing until it seats on the crankshaft.



002029

Oil the end of the crankshaft. Use Crankshaft Bearing/Sleeve Installer, P/N 338647, to drive a new sleeve onto the crankshaft until the installer contacts the lower main bearing.



002030

If the installer sticks on the sleeve after installation, thread Slide Hammer, P/N 391008, into installer and pull it off.

**IMPORTANT:** Inspect sleeve after installation. Sleeve must not be used if surface is damaged.

Use retaining ring pliers to install bearing retaining ring with sharp edge facing away from bearing.

Lubricate a new driveshaft O-ring and lightly lubricate crankshaft splines with *Moly Lube*. Install O-ring in sleeve.

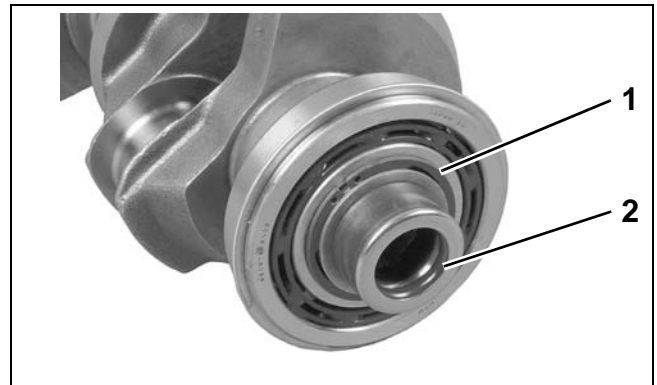

1. Bearing retaining ring  
2. O-ring

002031

Lubricate the center main bearings and split sleeves with outboard lubricant and install them in their original positions. The split sleeve ring grooves must face toward driveshaft (lower) end of crankshaft when installed.

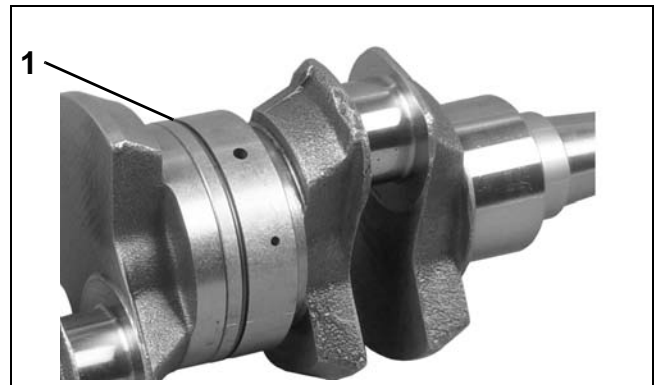

1. Groove toward driveshaft end

002032

Lightly coat the outside edge of a new lower housing seal with *Gasket Sealing Compound*. Press against outer case of the seal to install seal in the

# POWERHEAD

## POWERHEAD ASSEMBLY

lower housing with extended lip facing down. Lubricate seal lip with *Triple-Guard* grease.

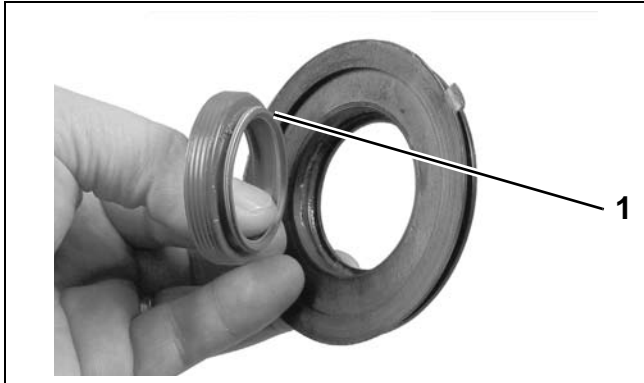

1. Seal lip

002036

Lubricate upper main bearing with outboard lubricant and install on crankshaft.

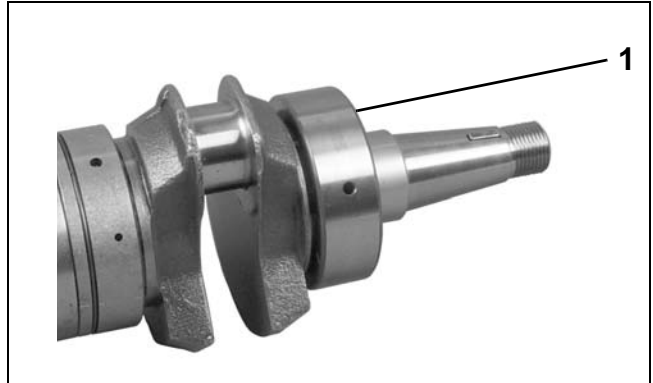

1. Upper main bearing

002033



002037

Pack lip of upper oil seal with *Moly Lube*. Place seal on crankshaft with lip down and enclosed face up. Do not apply sealer to outside edge of the seal.

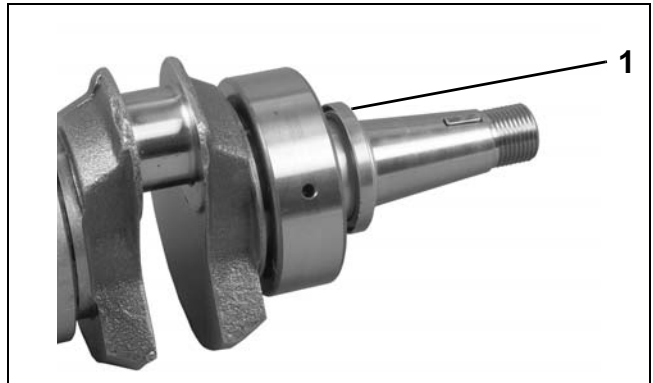

1. Upper oil seal

002034

Install a new O-ring on the lower housing. Before installing crankshaft into cylinder block, apply a thin coat of *Gasket Sealing Compound* to outer edge of O-ring.

Place lower seal housing on crankshaft.



1. Lower seal housing  
2. O-ring

002038



## Pistons and Connecting Rods

**NOTICE** It is very important that the pistons in this engine are installed in the correct location and direction. Engine damage will occur if installed incorrectly.

New pistons are stamped "EXH." This marking should be turned toward the exhaust side of the block. The splash bowl on the dome of the piston will be located toward the top and starboard side of the block.

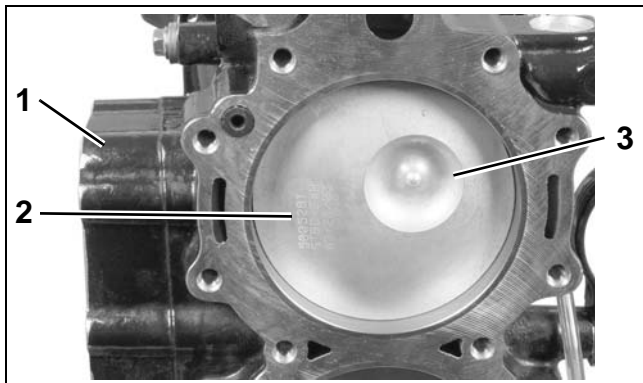

1. Exhaust side of block
2. Stamped markings
3. Splash bowl

002049

**NOTICE** It is also very important that the connecting rods are installed with the alignment dots and the diagonal oil hole facing up, toward the flywheel.

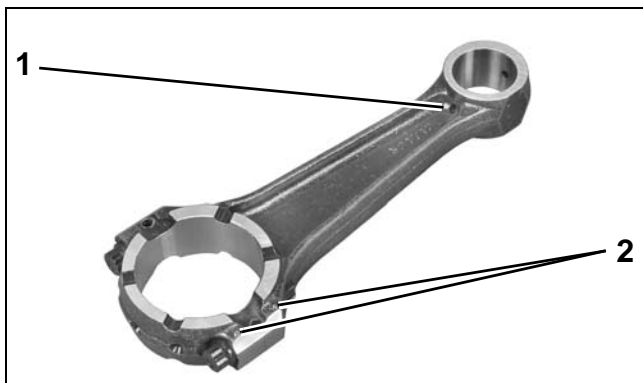

1. Oil hole
2. Raised dots

002055

Apply *Needle Bearing Grease* to the wrist pin bearings. Install the bearings in the small end of the connecting rod. Align bearings with Wrist Pin Bearing Tool, P/N 336660.

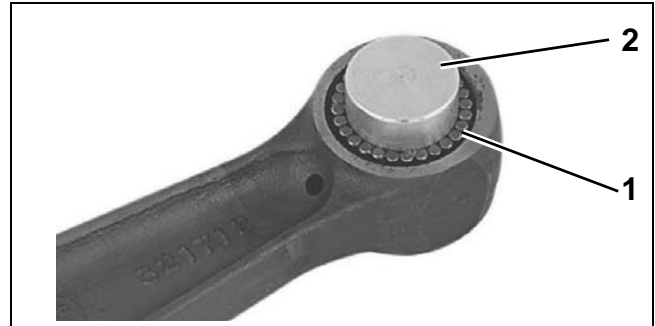

1. 28 needle bearings
2. Wrist pin bearing tool

24903

Place the two wrist pin thrust washers on the tool with flat side of the washers facing out.

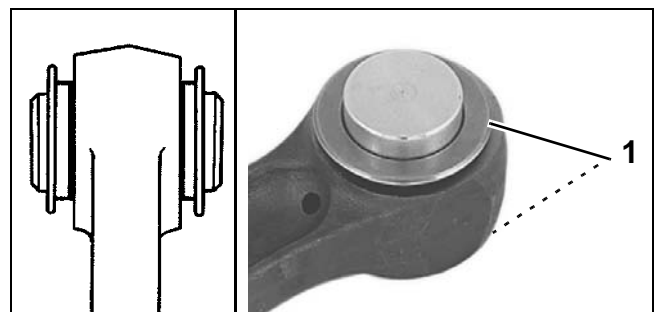

1. Wrist pin thrust washers

DR3480  
24902

Oil the wrist pin bore and wrist pin. Place connecting rod, with bearings, washers, and tool, into the piston with the alignment dots facing the top of the piston.

Install wrist pin through piston and connecting rod, pushing bearing tool out through the piston.

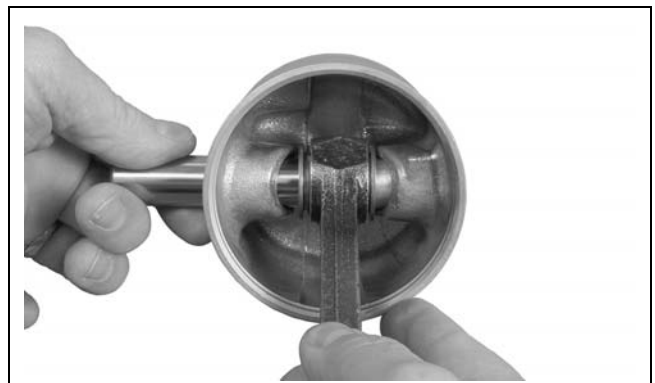

002057

## POWERHEAD POWERHEAD ASSEMBLY

Use Wrist Pin Cone, P/N 318600, and Driver, P/N 318599, to install new wrist pin retaining rings in each wrist pin hole. Gap of retaining ring faces up, away from notch in piston.

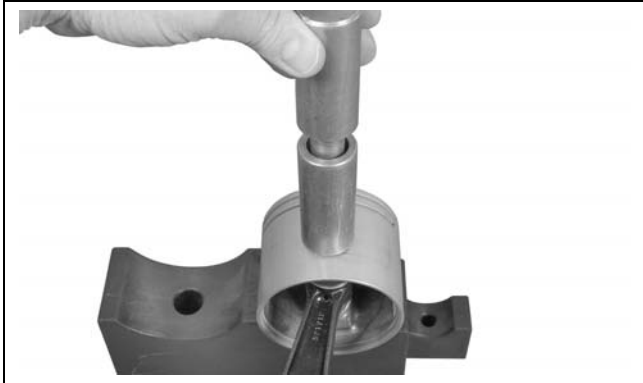

002058

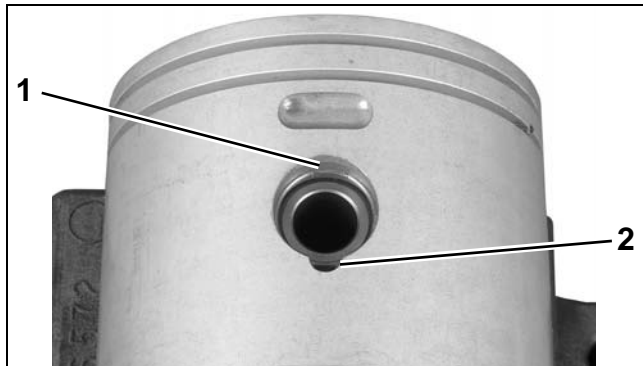

1. Gap of retaining ring
2. Notch in piston

002050

### Installing Pistons

When all pistons and connecting rods are assembled, install piston ring sets. Be sure rings are installed in the cylinder used to test ring end gap. Refer to **POWERHEAD INSPECTION** on p. 201.

**IMPORTANT:** Be sure gap of ring fits squarely around dowel pin.

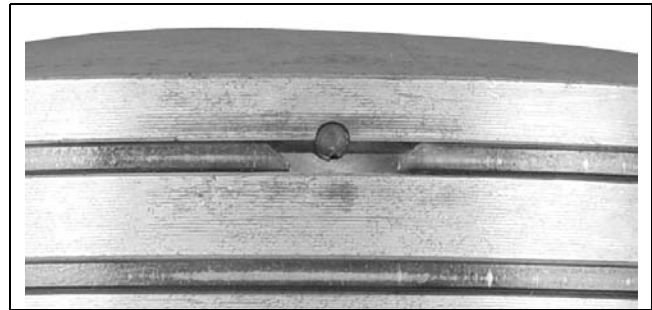

002048

**NOTICE** Before continuing, make sure that all *Gel-Seal II* has been removed from the cylinder block and crankcase mating flanges. If traces of hardened *Gel-Seal II* are left, main bearings could be misaligned. Refer to **CYLINDER BLOCK CLEANING** on p. 200.

Coat pistons, rings, cylinder walls, and an appropriate ring compressor with outboard lubricant.

Center connecting rod in piston and locate piston rings on dowel pins. Place appropriate ring compressor on piston.

Slide piston and rod assembly into the correct cylinder, as marked during disassembly. Guide connecting rod through cylinder block to avoid scratching cylinder wall.



1. Ring compressor

002059

Repeat steps for each piston.

## Cylinder Head Installation

Install a new thermostat seal in cylinder head with side marked "TO CYL HEAD" facing toward thermostat.

Refer to **THERMOSTAT SERVICING** on p. 182 before installing cylinder head.

Lightly lubricate new cylinder head O-rings with *Triple-Guard* grease and install in cylinder head.

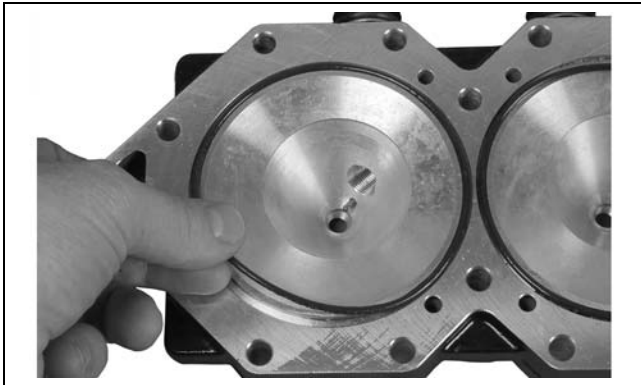

002061

Apply soapy water to water dam and insert into block.

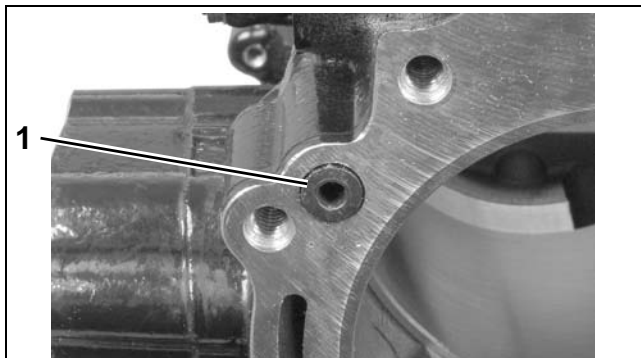

1. Water dam

002062

Apply a 1/16 in. (2 mm) bead of *RTV Adhesive* around each water passage on the block and cylinder head as shown.

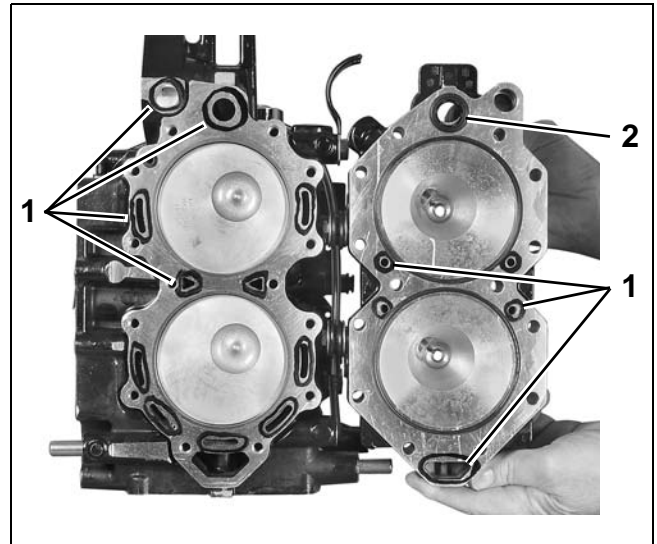

1. *RTV sealant*  
2. *Thermostat seal*

002272

Install cylinder head with the thermostat toward the top. Place ignition coil brackets as shown below.

Apply outboard lubricant to screw threads and install the cylinder head screws. **DO NOT** use any sealant or locking compound on threads.

# POWERHEAD

## POWERHEAD ASSEMBLY

Following sequence stamped on cylinder head, tighten all screws **in stages** to a torque of 168 to 192 in. lbs. (19 to 21.7 N·m).

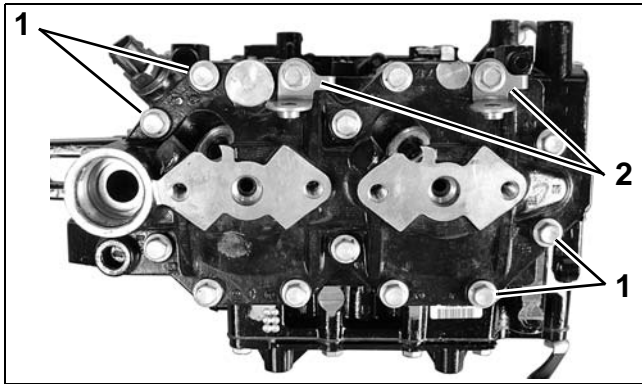

**2-Cylinder Models** 007850  
 1. Cylinder head screws  
 2. Ignition coil bracket

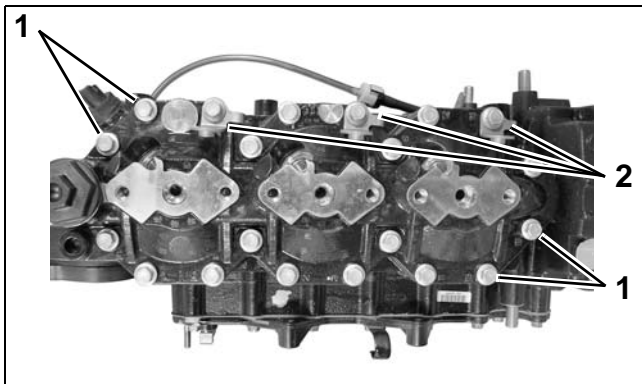

**3-Cylinder Models** 008192  
 1. Cylinder head screws  
 2. Ignition coil bracket

## Crankshaft and Connecting Rod Installation

Apply *Gasket Sealing Compound* to lower oil seal groove in cylinder block. **DO NOT** put any sealer in upper seal groove.

Check that main bearing alignment dowel pins are seated in the block.

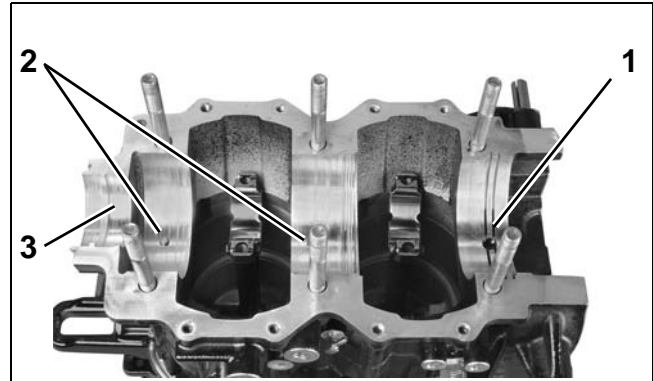

002262  
 1. Gasket Sealing Compound  
 2. Dowel pins  
 3. No sealer here

Push all pistons to the top of cylinders. Remove numbered connecting rod caps.

Gently lower crankshaft into place.

- Align tab on lower bearing seal housing with hole in crankcase.
- Align upper oil seal in groove.
- Locate each main bearing on its dowel pin. A mark placed on the bearing race opposite the dowel pin hole will help in the alignment process.

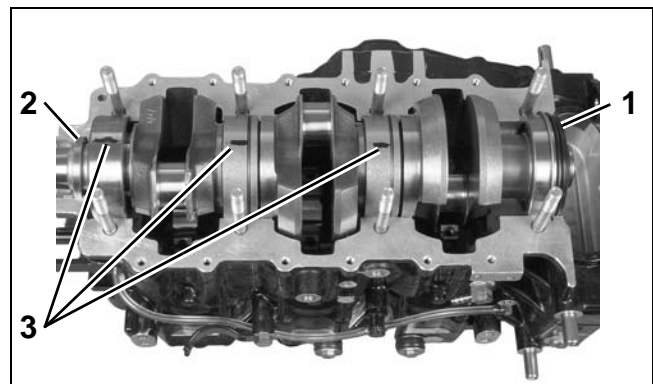

002070  
 1. Lower seal housing  
 2. Upper oil seal  
 3. Alignment marks

Lubricate each crankpin and bearing assembly with outboard lubricant. Slowly pull connecting rod up to crankshaft and install bearing halves.

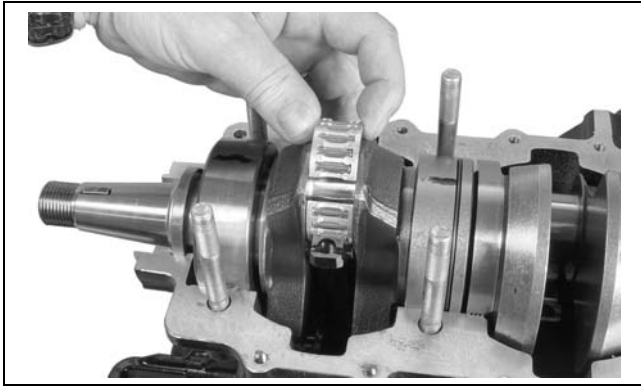

002115

Lubricate rod cap screw threads and under screw head mating surface with outboard lubricant. Align dot on rod cap with dot on the connecting rod. Install rod cap screws finger tight (NO MORE than 6 in. lbs. (1 N·m) maximum).

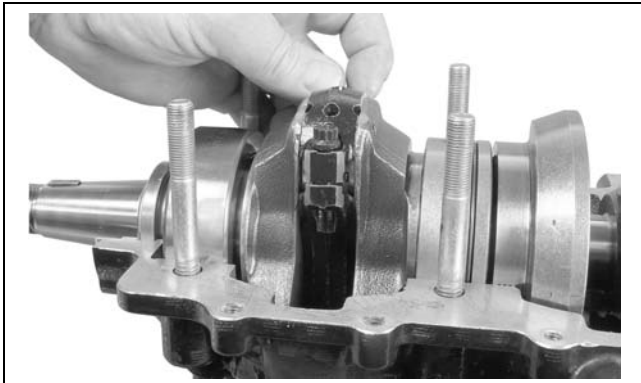

002116

**IMPORTANT:** Be sure alignment dot on rod cap matches dot on rod and that both dots face fly-wheel.

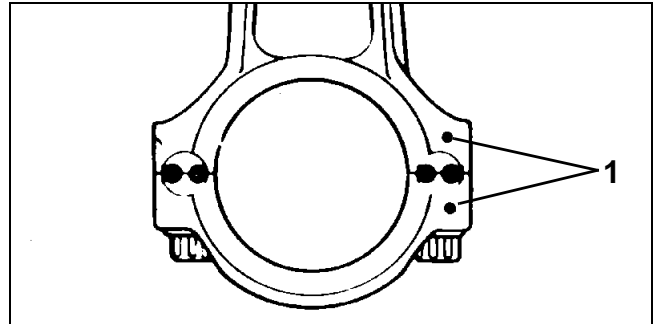

1. Alignment dots

53628

**NOTICE** Tightening rod cap screws without Alignment Fixture, P/N 396749, or using an incorrect procedure could cause permanent damage to the connecting rod and crankshaft. To maintain accurate torque values, keep torque wrench extension length to a minimum.

Install Rod Cap Alignment Fixture, P/N 396749, **before** tightening rod cap screws. Align the flat marked "SET" on the rod engagement stop with the arrow on the frame. Position stop at the center setting (one line showing). Rotate adjustment knob 180° to lock in position.

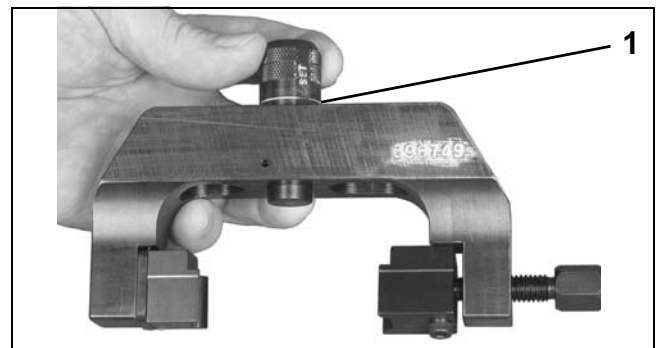

1. Center position, one line showing

002484

## POWERHEAD POWERHEAD ASSEMBLY

Secure restraining jaw "C" and forcing jaw "D" to frame.

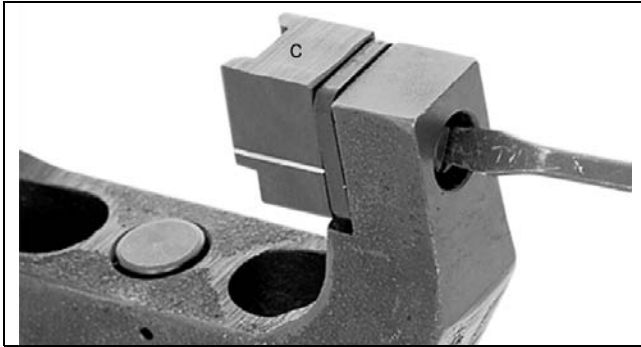

Restraining Jaw "C"

21591

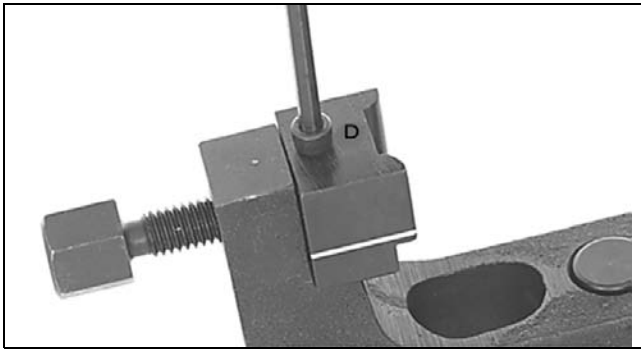

Forcing Jaw "D"

21594

Apply a light coat of outboard lubricant to the corners of the connecting rod and rod cap. Place frame on connecting rod using the following procedure.

- Place frame onto the connecting rod so the contact area of the jaw is centered on the side of the rod.
- Tighten forcing screw until jaws contact connecting rod.
- Slide frame down until adjustment stop contacts the rod cap. The groove lines on the jaws must be centered on the rod/crankpin diameter.

- Tighten the forcing screw to a torque of 14 to 16 in. lbs. (1.6 to 1.8 N·m).

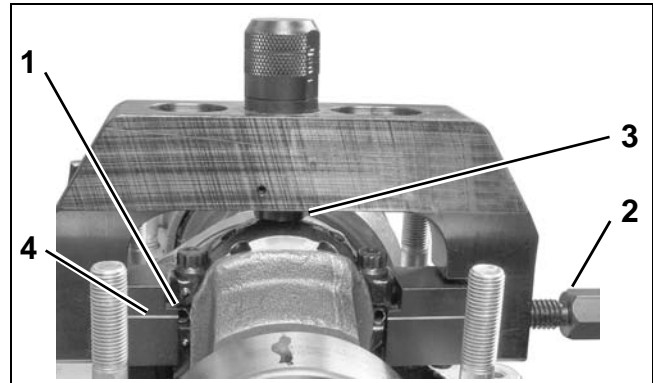

1. Contact area of jaw
2. Forcing screw
3. Adjustment stop
4. Groove line

002071

**IMPORTANT:** Make sure that frame is squarely in position and that rod and cap are aligned.

Loosen both rod cap screws one-quarter turn.

Use Torquing Socket, P/N 331638, to tighten rod cap screws in three stages:

- Apply first torque of 40 to 60 in. lbs. (5 to 7 N·m) to both rod cap screws.
- Tighten screws to a torque of 14 to 16 ft. lbs. (19 to 21.7 N·m).
- Apply final torque of 30 to 32 ft. lbs. (41 to 43 N·m).

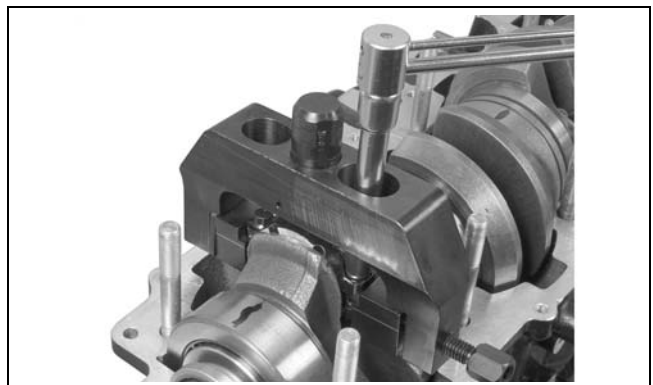

002072

**IMPORTANT:** If a new screw is used, it must be installed as above. Then, it must be removed, re-lubricated, and installed again.

Loosen forcing screw and remove the frame.

Test at least three corners of the rod and cap joint with a pick. Joint must be smooth with no step.

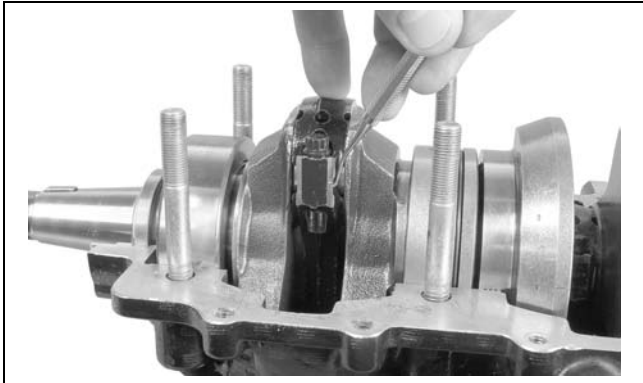

002117

## Crankcase Assembly

Make sure crankshaft is still seated on dowel pins before assembling crankcase.

Thoroughly clean and degrease the mating flanges of the crankcase and cylinder block with a non-petroleum based solvent, such as isopropyl alcohol or acetone, and let air dry.

**IMPORTANT:** DO NOT allow solvent to get on internal components. Clean only the mating flanges.

Apply *Gasket Sealing Compound* to lower oil seal groove in crankcase. DO NOT put any sealer in upper seal groove.

Use a small brush with a tapping motion to apply a thin, even coat of *Gel-Seal II* sealant to the crankcase mating flange. The sealer must not come within 1/4 in. (6.4 mm) of bearings.

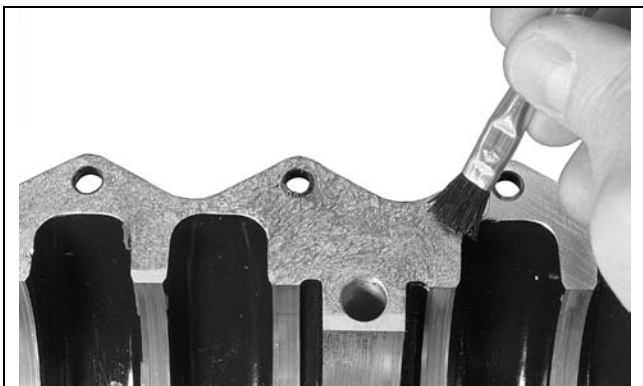

TYPICAL

003874

**IMPORTANT:** *Gel-Seal II* has a shelf life of at least one year when stored at room temperature. Test the *Gel-Seal II* or replace it if the age of the tube cannot be determined. Using old *Gel-Seal II* could cause crankcase air leaks.

**IMPORTANT:** The use of *Locquic Primer* is NOT recommended. If primer is used, crankcase halves must be assembled and tightened within ten minutes after the *Gel-Seal II* has been applied.

Lower the crankcase into place. Make sure that upper oil seal and lower seal housing are seated in grooves.

Apply outboard lubricant to the main bearing studs. Install nuts and washers finger tight, no more than 60 in. lbs. (7 N·m).

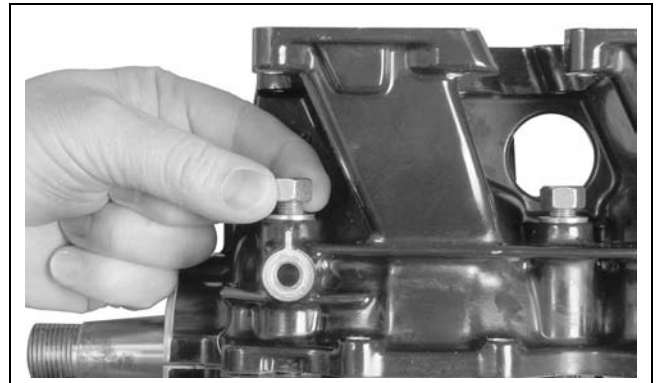

002271

When the crankcase is seated, install and firmly seat the crankcase taper pin.

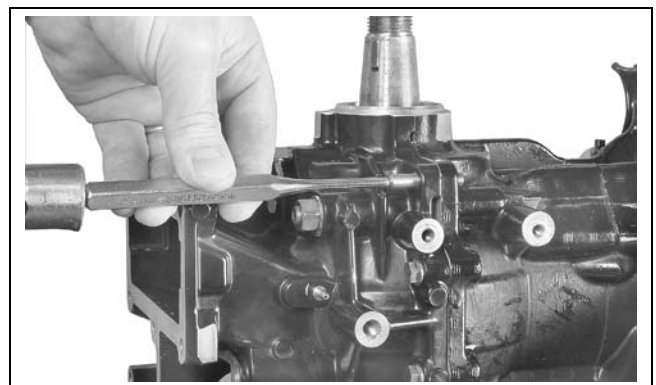

002260

Tighten main bearing nuts **in stages** to a final torque of:

- 26 to 30 ft. lbs. (35 to 41 N·m).

## POWERHEAD POWERHEAD ASSEMBLY

Start in the center and work outward in a spiral pattern.

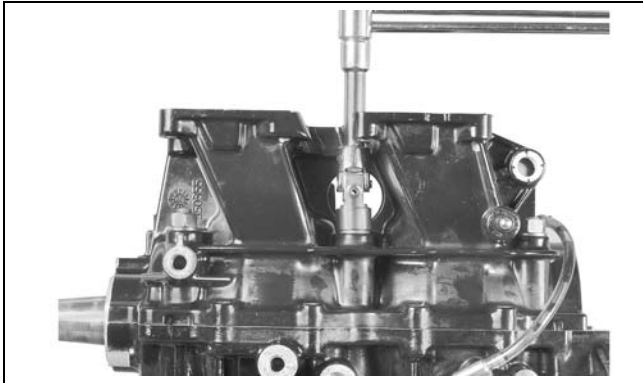

002254

Apply *Nut Lock* to crankcase flange screws. Install screws and tighten to a torque of 60 to 84 in. lbs. (7 to 9.5 N·m).

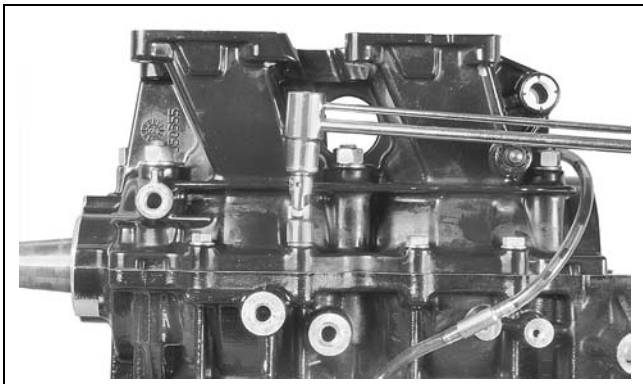

002259

Test that the crankshaft spins freely without binding.

**IMPORTANT:** After powerhead has been assembled, allow at least two hours for *Gel-Seal II* to cure before running outboard.

Apply *Gasket Sealing Compound* to both sides of a new water cover gasket. Place gasket and cover on cylinder block.

Apply *Nut Lock* to cover screws. Position J-clamps as shown. Tighten all screws to a torque of 60 to 84 in. lbs. (7 to 9.5 N·m).

Note: 3-Cylinder models include a double-ended stud and use a lock washer under the J-clamp.

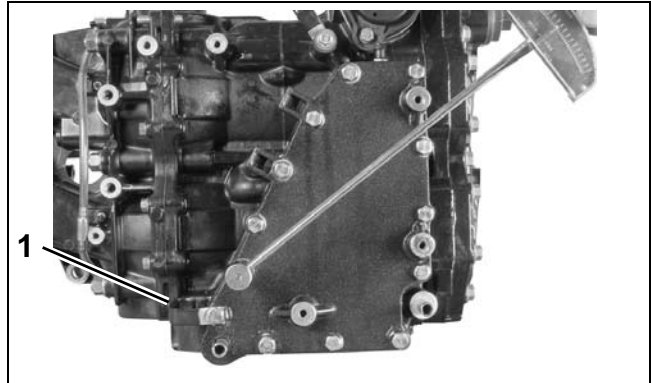

2-Cylinder models  
1. J-clamp

002242r

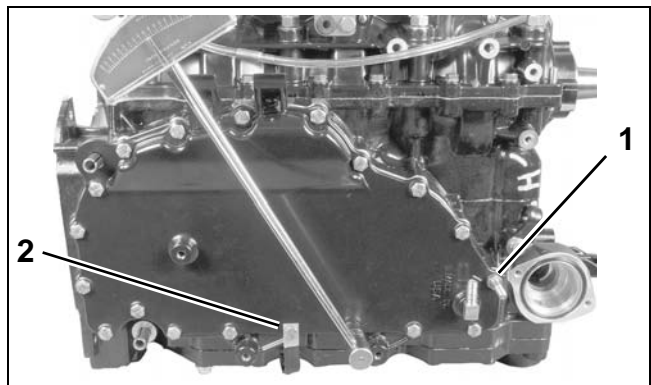

3-Cylinder models  
1. Double-ended stud  
2. J-clamp

002122

## Shift Linkage Installation

Place the spring, guide, and ball of the shift detent assembly into the crankcase. Lubricate with *Triple-Guard* grease.

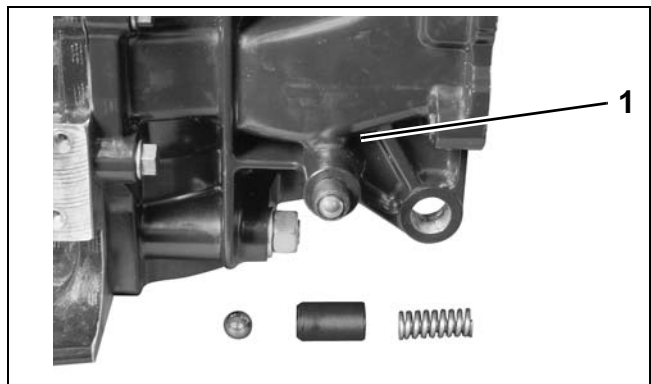

1. Shift detent assembly

002135



Lubricate shift linkage bosses at the base of the crankcase with *Triple-Guard* grease. Insert bushings into bosses.

Apply *Triple-Guard* grease to the shaft and detent of the shift lever assembly. Guide shaft through bushings in crankcase.

Install cotter pin and washer on the shaft (2-cylinder models).

Install shift rod lever and tighten retaining screw to a torque of 60 to 84 in. lbs. (7 to 9.5 N·m).

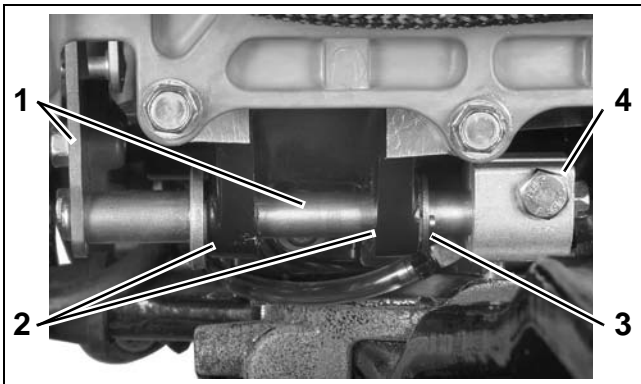

1. Shift lever and shaft
2. Bushing
3. Cotter pin and washer
4. Shift rod lever screw

002246

Apply *Triple-Guard* grease to shoulder of shift arm screw and *Nut Lock* to threads. Install arm, screw, and washer and tighten screw to a torque of 120 to 144 in. lbs. (13.5 to 16 N·m).

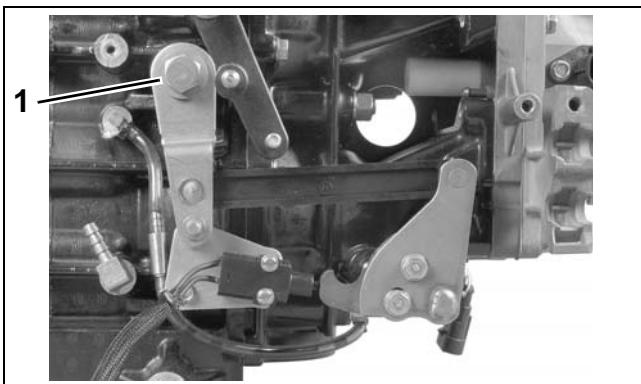

1. Shift lever screw

002250

## Throttle Linkage Installation

Apply *Nut Lock* to threads of throttle lever screw.

Insert spring into cavity of throttle return lever.

Install lever, screw, and washer on crankcase and hook spring on rib as shown. Tighten screw to a torque of 120 to 144 in. lbs. (13.5 to 16 N·m).

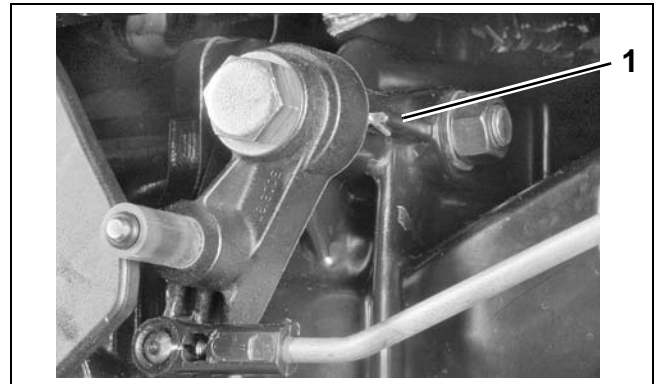

- 2-Cylinder models**  
1. Throttle lever spring

002255

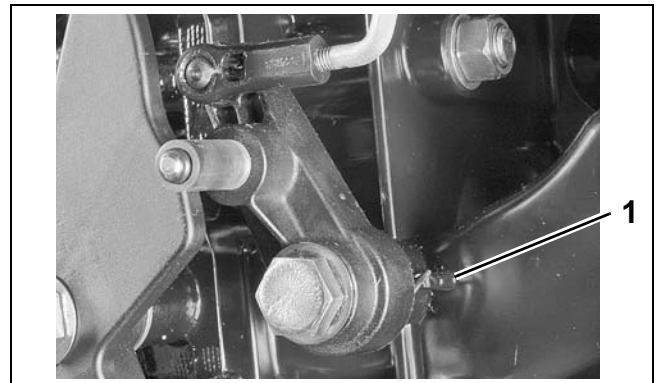

- 3-Cylinder models**  
1. Throttle lever spring

002256

Apply *Nut Lock* to threads of throttle cam screw. Install cam, screw, and washer on cylinder block

## POWERHEAD POWERHEAD ASSEMBLY

and tighten screw to a torque of 120 to 144 in. lbs. (13.5 to 16 N·m).

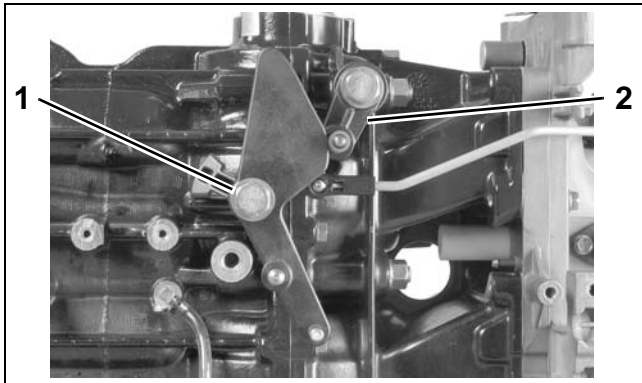

**2-Cylinder models**  
1. Throttle lever screw  
2. Throttle return lever

002245

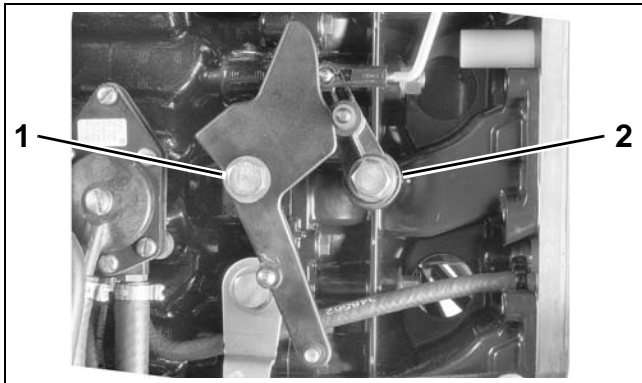

**3-Cylinder models**  
1. Throttle lever screw  
2. Throttle return lever

002257

**IMPORTANT:** Do not lubricate throttle levers or shoulder screws.

## Final Powerhead Assembly

Install the reed plate and throttle body assemblies. Refer to **Intake Manifold Service** on p. 149.

Install oil recirculating hoses and check valves. Refer to **OIL RECIRCULATION DIAGRAMS** on p. 158, or **POWERHEAD VIEWS** on p. 221.

Install thermostat assembly. Refer to **THERMOSTAT SERVICING** on p. 182.

Install pressure valve assembly. Refer to **PRESSURE RELIEF VALVE SERVICING** on p. 183.

Install shift linkage. Refer to **Shift Linkage Installation** on p. 212.

Install throttle linkage. Refer to **Throttle Linkage Installation** on p. 213.

Install fuel injectors and ignition coils. Refer to **Fuel Injector Installation** on p. 147 and **IGNITION COIL SERVICING** on p. 112.

**IMPORTANT:** All injectors must be installed in their original location. Improper injector installation can result in powerhead failure.

Install stator and flywheel. Refer to **FLYWHEEL AND STATOR SERVICING** on p. 110.

Install electrical harness, then install *EMM*. Refer to **EMM SERVICING** on p. 70.

Install fuel pump assemblies, fuel manifolds, and filter. Refer to **FUEL COMPONENT SERVICING** on p. 142.

Install the oil tank and oil injection hoses. Refer to **Oil Tank Assembly** on p. 169.

Install the electric starter. Refer to **Starter Starter Installation** on p. 115.

### **WARNING**

To prevent fire and explosion hazard, make sure all electrical and ignition wiring is routed and clamped in original positions.

# UPPER MOUNT SERVICING (3-Cylinder)

## Removal

Remove mount retainer screw.

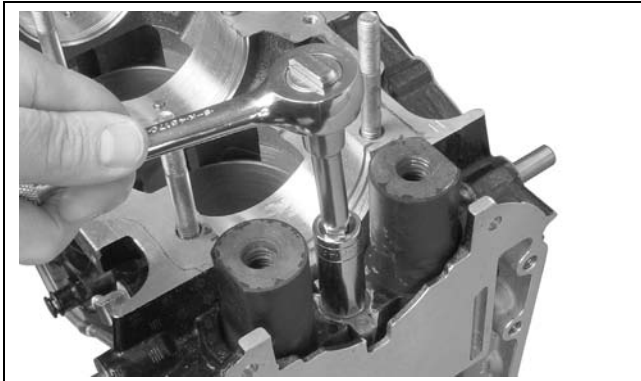

002069

Insert suitable punch in taper of mount retainer. Tap side of punch to loosen mount retainer.

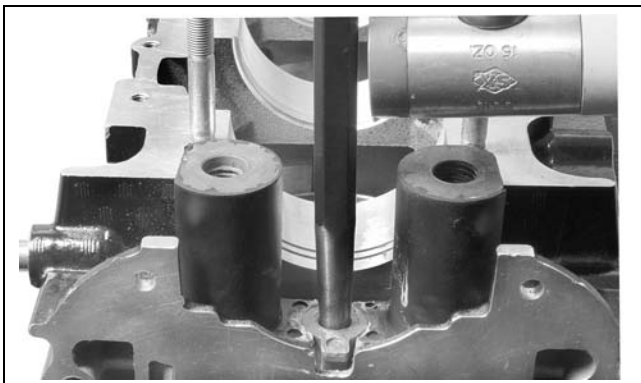

002130

Dislodge mount assemblies and remove.

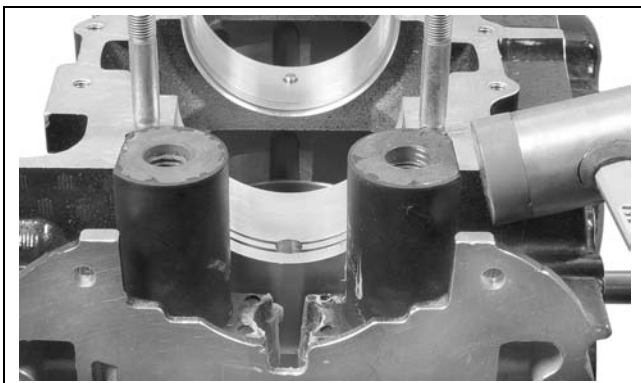

002132

Inspect mounts and replace if necessary.

**IMPORTANT:** The motor mount, washer, and screw are serviced as an assembly. Do not disassemble.

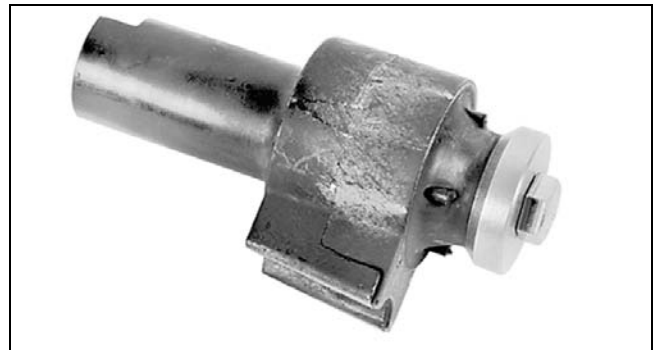

39820

## Installation

Place mount assemblies in position, with flats facing away from each other.

Apply *Moly Lube* to all sides of retainer and install between mounts.

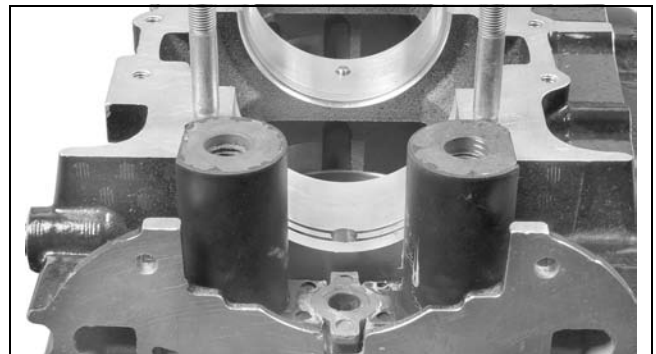

002133

Install the retainer screw and tighten to a torque of 15 to 20 ft. lbs. (20 to 27 N·m).

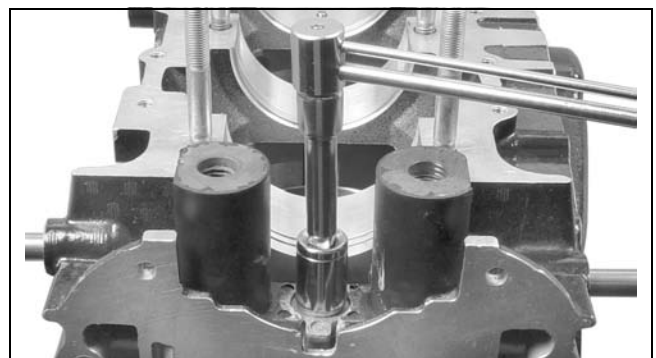

002134

# POWERHEAD INSTALLATION

## Powerhead Mounting – 2-Cylinder Models

Apply *Permatex No. 2* to both sides of a new base gasket around the exhaust port only. Install gasket on exhaust housing. To ensure proper sealing, mating surfaces must be clean and dry.

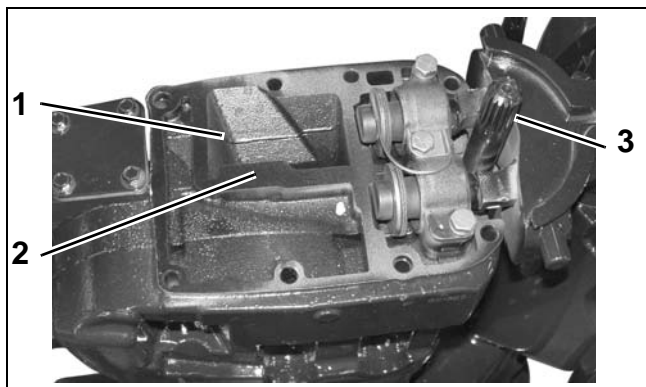

1. Exhaust port  
 2. Clean surface  
 3. Moly Lube

004972

Coat the driveshaft splines with *Moly Lube*. Do not apply lubricant to end of driveshaft.

Use Lifting Fixture, P/N 396748, and hoist to slowly lower powerhead onto exhaust housing. If necessary, rotate flywheel in a clockwise direction to align crankshaft and driveshaft splines.

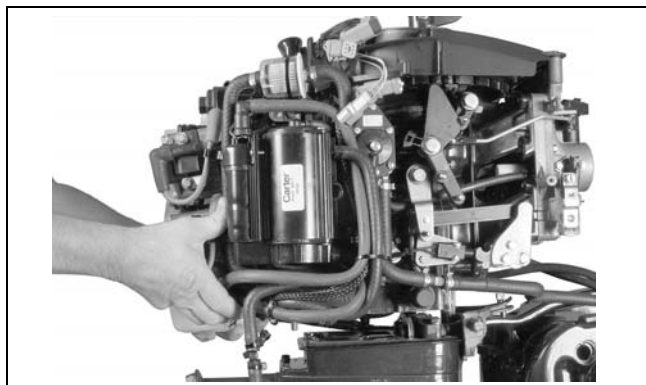

002269

Apply *Triple-Guard* grease to the threads, and *Gasket Sealing Compound* to the shank of the powerhead screws.

Loosely install all powerhead screws before tightening:

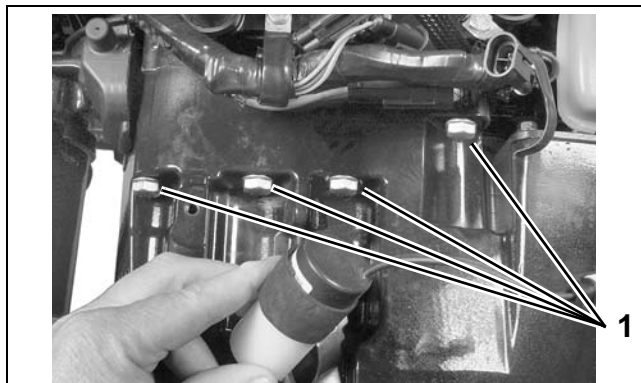

1. Powerhead screws

004292

Tighten the eight powerhead screws to a torque of 18 to 20 ft. lbs. (24 to 27 N·m) in the sequence shown.

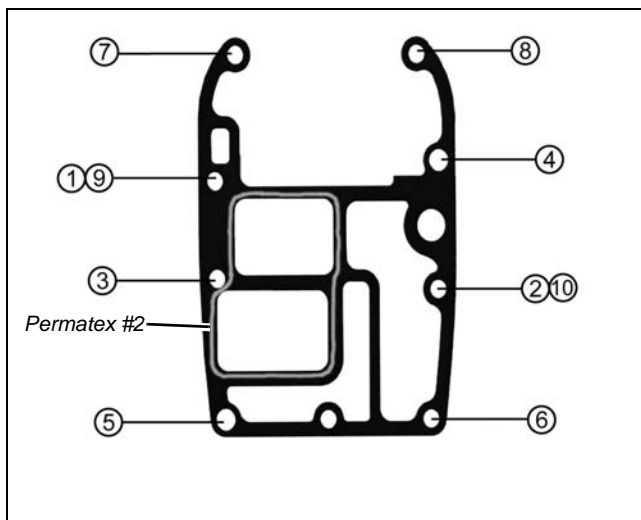

Large screw torque sequence, 1 – 10

002175

**IMPORTANT:** Retighten powerhead mounting screws after outboard has been run at full operating temperature and allowed to cool.

Place the shift rod in the shift rod lever. Install the retaining pin and washer. Tighten pin to a torque of 60 to 84 in. lbs. (7 to 9.5 N·m).



1. Shift rod screw

002171

Check shift linkage adjustment. Refer to **Shift Linkage Adjustment** on p. 220.

**IMPORTANT:** Make sure the gearcase shifts completely into both forward and reverse and that propeller shaft spins freely in neutral.

Apply *Nut Lock* to threads of exhaust water valve screws and tighten to a torque of 60 to 84 in. lbs. (7 to 9.5 N·m).

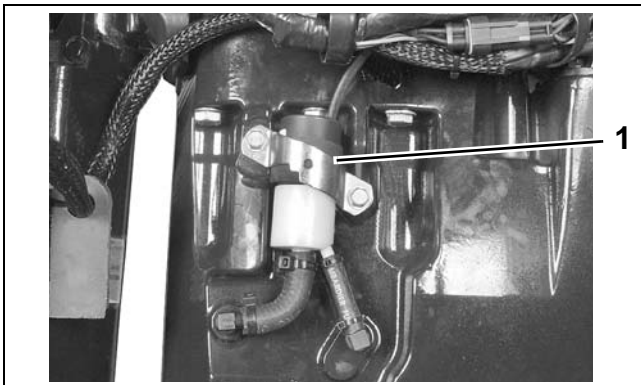

1. Exhaust water valve

004293

Connect cooling water hoses to exhaust housing.

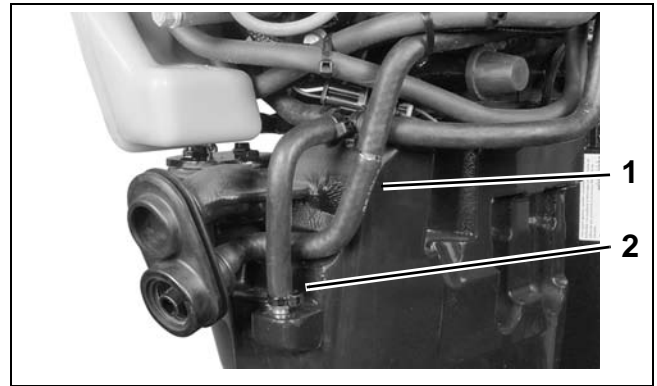

1. Overboard indicator hose  
 2. Drain hose

004298

Connect the power trim connectors and exhaust water valve connector (60, 65). Secure cables in clamps.

**ROPE START MODELS**

Install throttle cable and tiller shift rod.

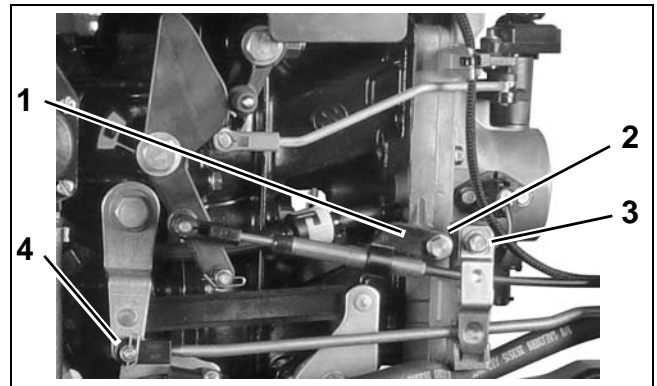

1. Cable anchor  
 2. Anchor screw  
 3. Cable retainer  
 4. Shift rod retainer

006526m

Refer to **Throttle Cable Adjustment** on p. 276, or **Throttle Cable Adjustment** on p. 287.

## POWERHEAD POWERHEAD INSTALLATION

Install recoil starter ratchet and housing on out-board. Refer to **RECOIL STARTER INSTALLATION** on p. 369.

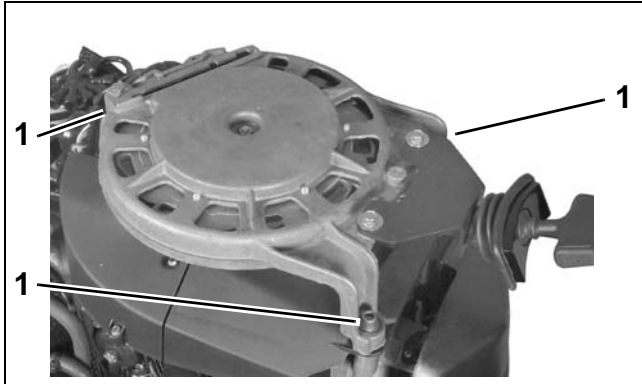

1. Starter housing screws (3)

002515

Install the lower engine covers. Refer to **LOWER COVER SERVICE** on p. 50.

### Powerhead Mounting – 3-Cylinder Models

Apply *Permatex No. 2* to both sides of a new base gasket around the exhaust port only. Install gasket on adapter. To ensure proper sealing, mating surfaces must be clean and dry.

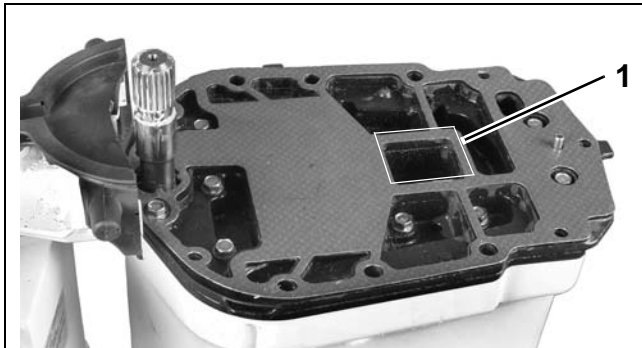

1. Apply Permatex No. 2 here

002164

Coat the driveshaft splines with *Moly Lube*. Do not apply lubricant to end of driveshaft.

Use Lifting Fixture, P/N 396748, and hoist to slowly lower powerhead onto exhaust housing. Guide into position over alignment pin at rear of exhaust housing. If necessary, rotate flywheel in a clockwise direction to align crankshaft and drive-shaft splines.



1. Alignment pin

002162

Apply *Triple-Guard* grease to the threads, and *Gasket Sealing Compound* to the shank of the powerhead screws.

Apply *Triple-Guard* grease to upper mount screw threads.

Loosely install all powerhead screws and upper mount screws before tightening.

- Tighten the six large powerhead screws to a torque of 18 to 20 ft. lbs. (24 to 27 N·m) in the sequence shown.
- Tighten the five small powerhead screws to a torque of 60 to 84 in. lbs. (7 to 9.5 N·m).

- Tighten the upper mount screws to a torque of 110 to 130 ft. lbs. (149 to 176 N-m). Make sure that screw heads are tight against steering arm.

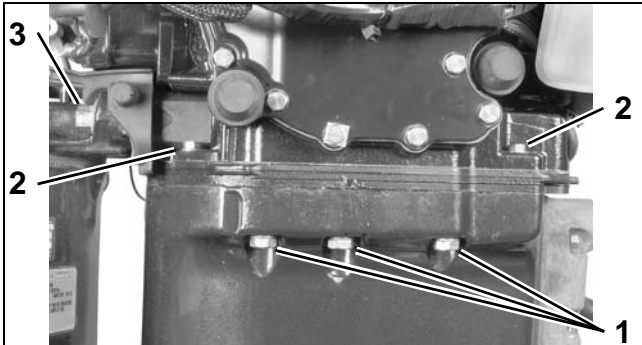

1. Large powerhead screws
2. Small powerhead screws
3. Upper mount screws

002153

Apply *Gasket Sealing Compound* to exhaust relief muffler gasket and retaining screws. Install muffler and tighten screws to a torque of 60 to 84 in. lbs. (7 to 9.5 N-m).

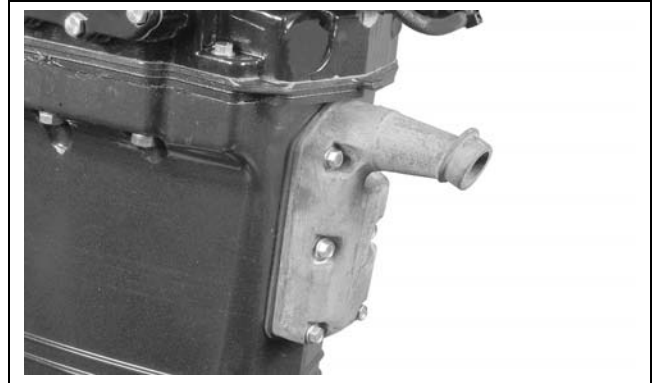

002163

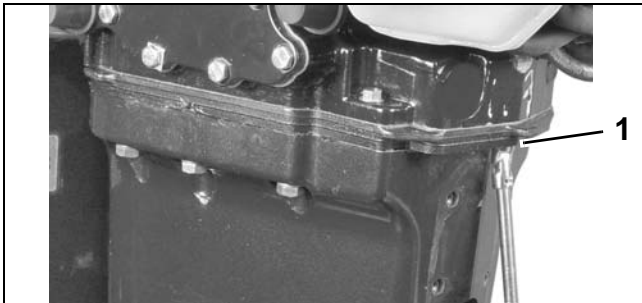

1. Rear small powerhead screw

002160

Place the shift rod in the shift rod lever. Install the retaining pin and washer. Tighten pin to a torque of 60 to 84 in. lbs. (7 to 9.5 N-m).



1. Shift rod screw

002013

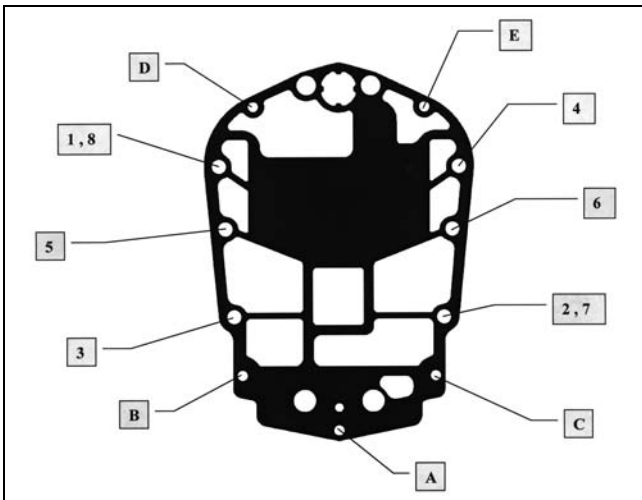

Large screw torque sequence, 1-8  
Small screw torque sequence, A-E

002167

**IMPORTANT:** Retighten powerhead mounting screws after outboard has been run at full operating temperature and allowed to cool.

Check shift linkage adjustment. Refer to **Shift Linkage Installation** on p. 212.

**IMPORTANT:** Make sure the gearcase shifts solidly into both forward and reverse and that propeller shaft spins freely in neutral.

## POWERHEAD POWERHEAD INSTALLATION

Connect the power trim connectors.



002152

Install the lower engine covers. Refer to **LOWER COVER SERVICE** on p. 50.

### Shift Linkage Adjustment

Adjust shift linkage as follows:

- Loosen adjustment screws on shift lever.
- Be sure that ball is centered in detent assembly.
- Adjust shift lever so that the screw hole in shift rod lever lines up with the hole in the gearcase shift rod when gearcase is in neutral.
- When correctly adjusted, the shift lever will be parallel with the vertical line of the outboard, and the distance between the shift lever pin and the center of the shift cable trunnion pocket should be approximately 7 in. (17.8 cm).

**IMPORTANT:** The shift rod height is the most critical of these adjustments and should not be moved during this procedure. Refer to **SHIFT ROD ADJUSTMENT** on p. 300, or **SHIFT ROD ADJUSTMENT** on p. 323.

- Tighten adjustment screws to 60 to 84 in. lbs. (7 to 9.5 N·m).

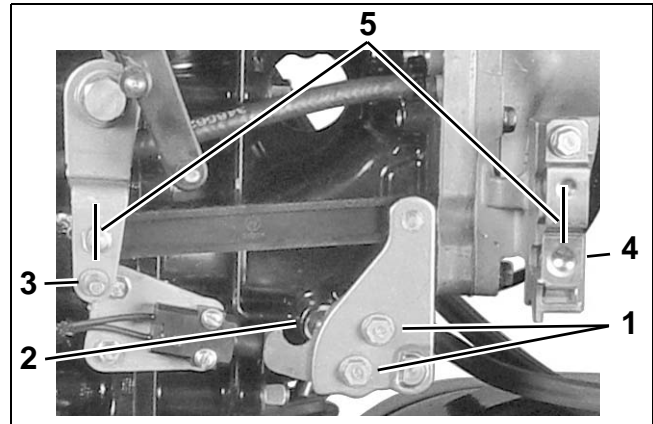

002125

1. Adjustment screws
2. Shift detent assembly
3. Shift lever pin
4. Trunnion pocket
5. 7 inch dimension

### Final Adjustments

**NOTICE** After installing a new or rebuilt powerhead, perform the following procedures before returning outboard to service:

- Adjust timing pointer.
- Index all spark plugs. Refer to **Spark Plug Indexing** on p. 42.
- Use *Evinrude Diagnostics* software to start powerhead break-in oiling. Refer to **Powerhead Break-In** on p. 67.
- Use *Evinrude Diagnostics* software to set TPS calibration. Refer to **TPS Calibration** on p. 114.
- Use *Evinrude Diagnostics* software to make sure engine management software version and revision are current. Update as required.
- Prime fuel system.
- Prime oiling system. Refer to **Oil Supply Priming** on p. 165.
- Use *Evinrude Diagnostics* software to check engine timing. Refer to **TIMING ADJUSTMENTS** on p. 113.
- Run outboard and check for water, fuel, or oil leaks.
- Make sure engine reaches correct operating temperature and does not overheat.



**2-Cylinder Port – Hose Routings**

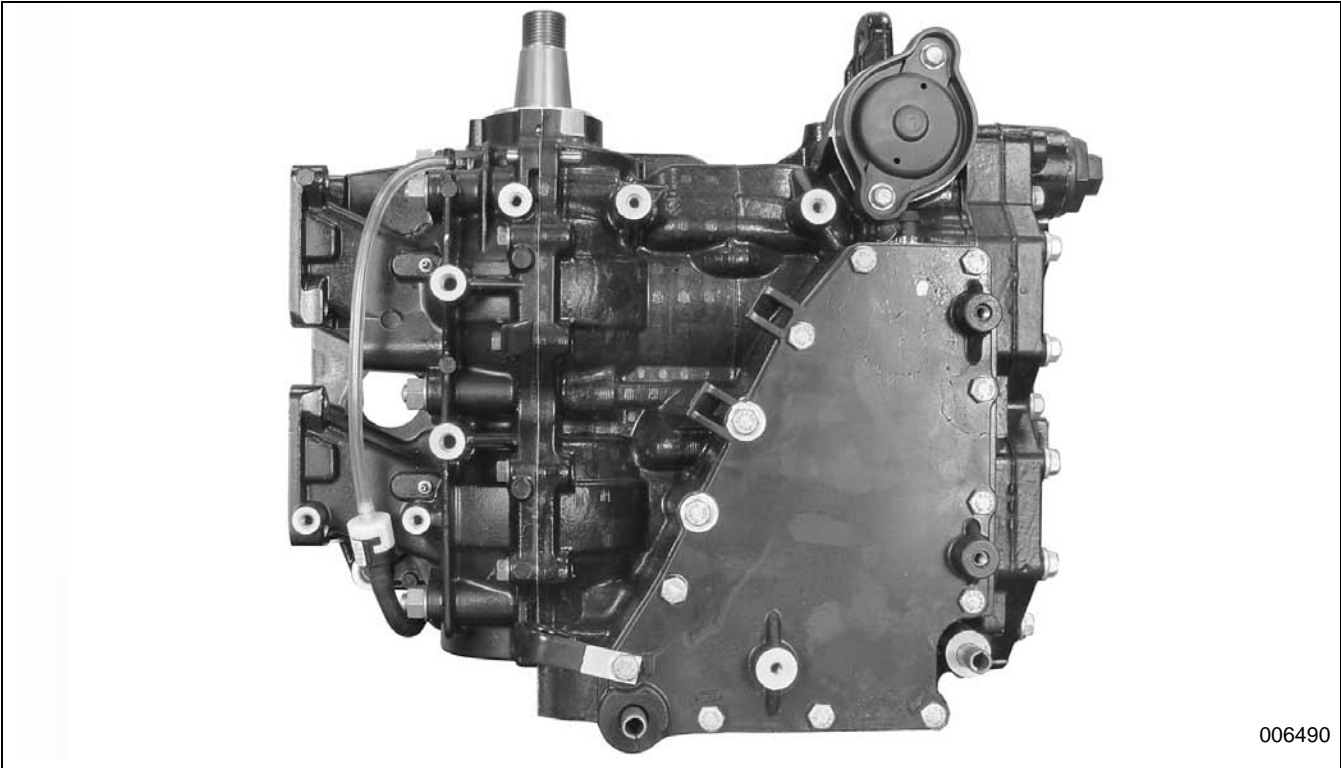

**2-Cylinder Starboard – Hose Routings**

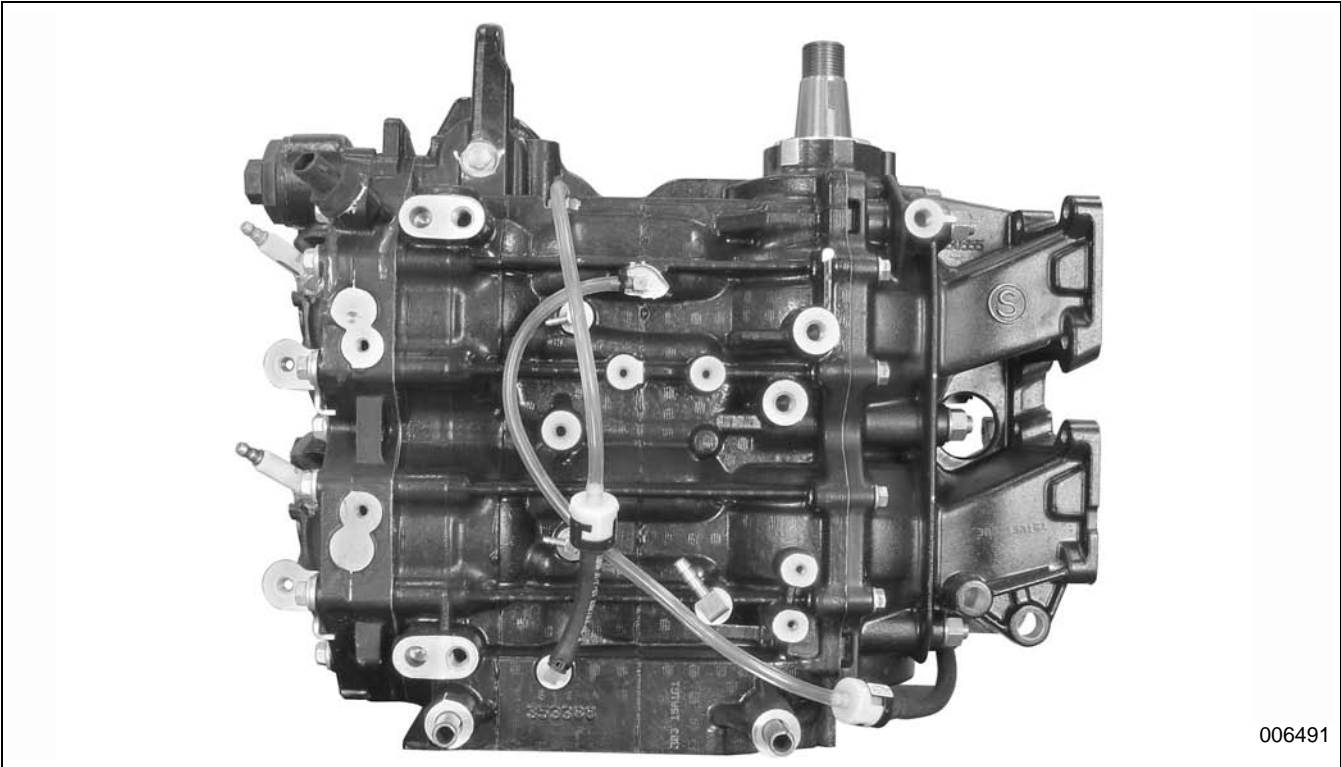

**POWERHEAD**  
**POWERHEAD VIEWS**

**2-Cylinder Port Dressed Powerhead**



008428

**2-Cylinder Starboard Dressed Powerhead**



008159

**2-Cylinder Port Rope Start Models**



**2-Cylinder Starboard Rope Start Models**



---

**POWERHEAD**  
**POWERHEAD VIEWS**

---

**2-Cylinder Front**



008160

**2-Cylinder Rear**

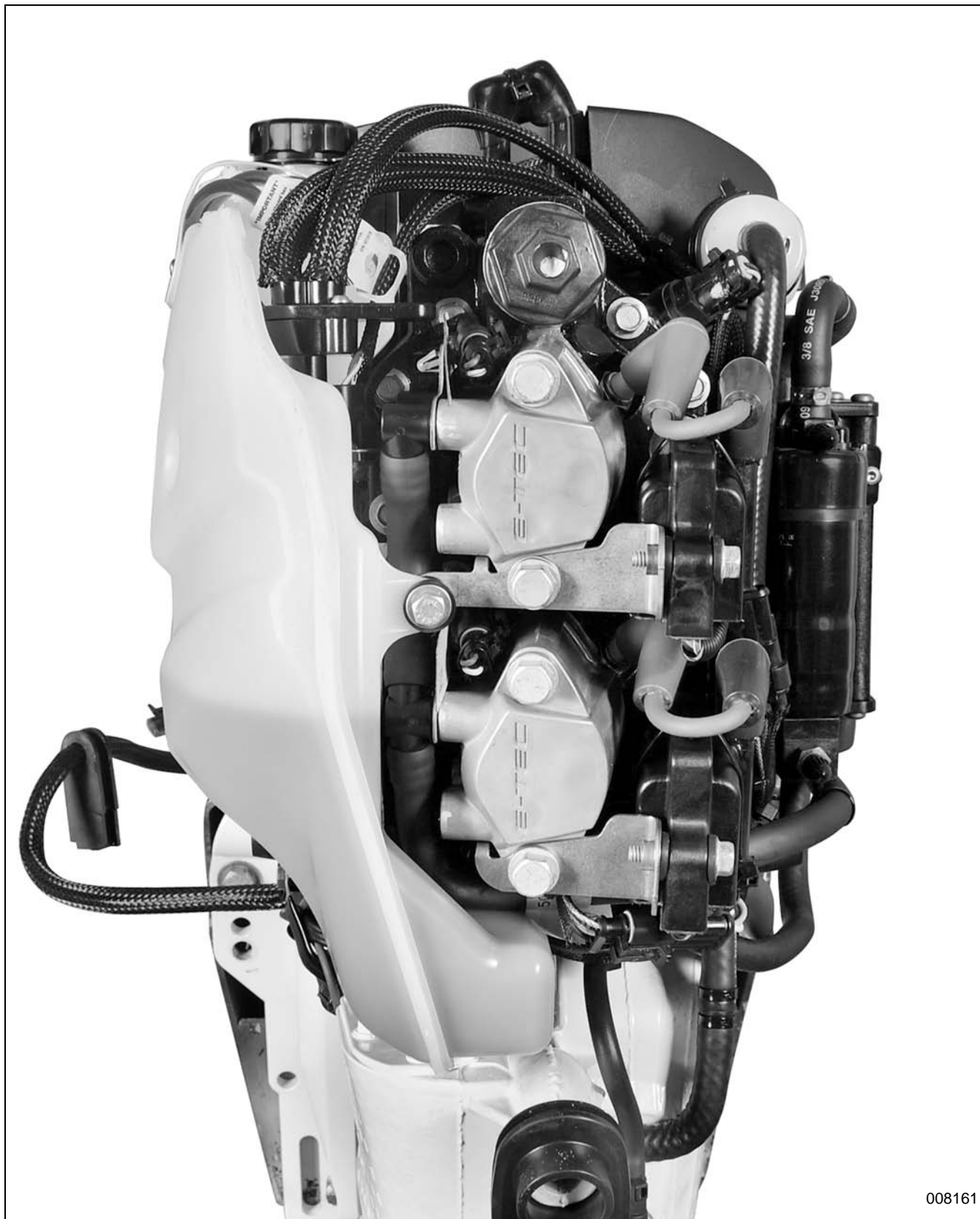

**10**

008161

---

**POWERHEAD**  
**POWERHEAD VIEWS**

---

**2-Cylinder Top**

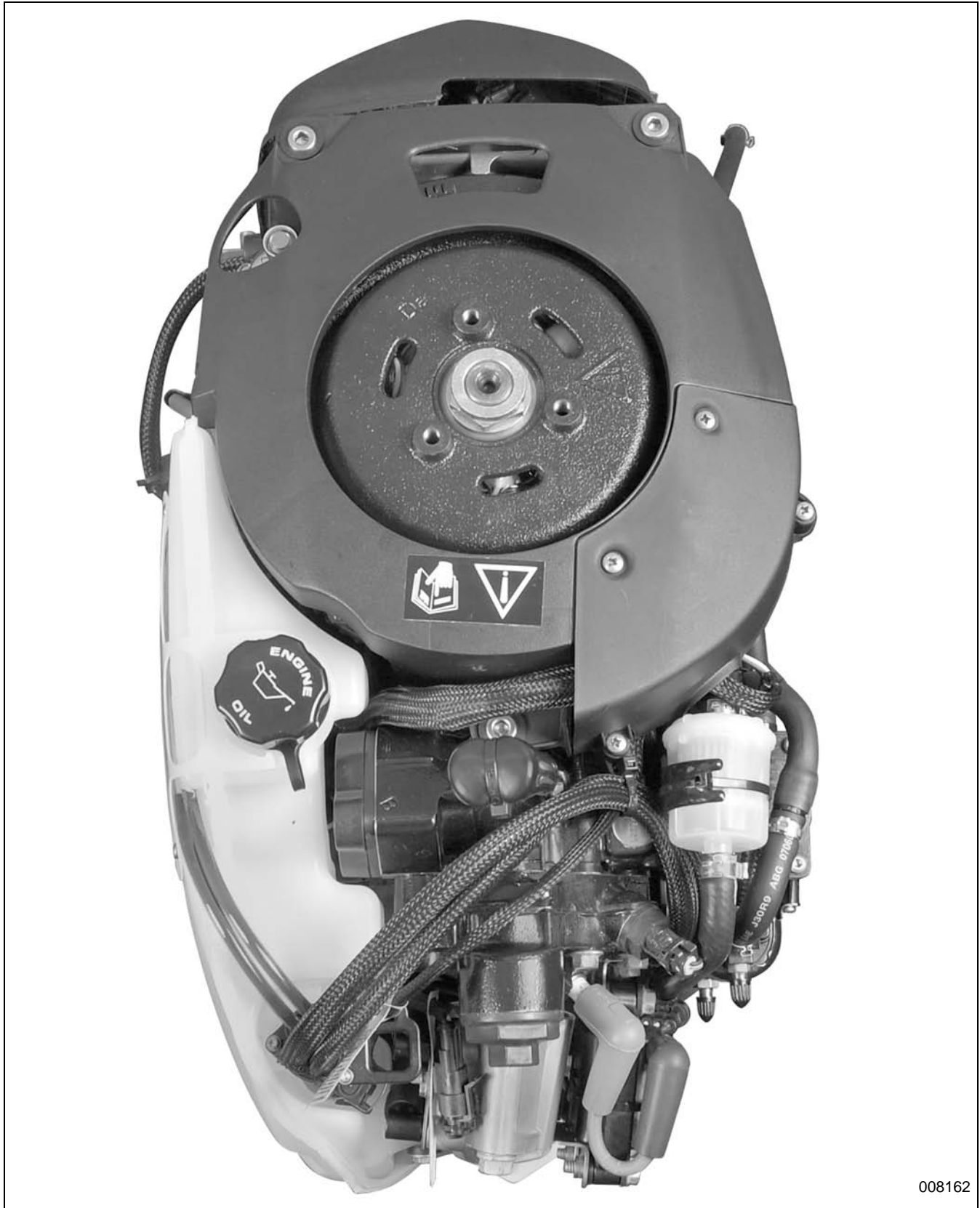

008162

**2-Cylinder Top, Rope Start Models**

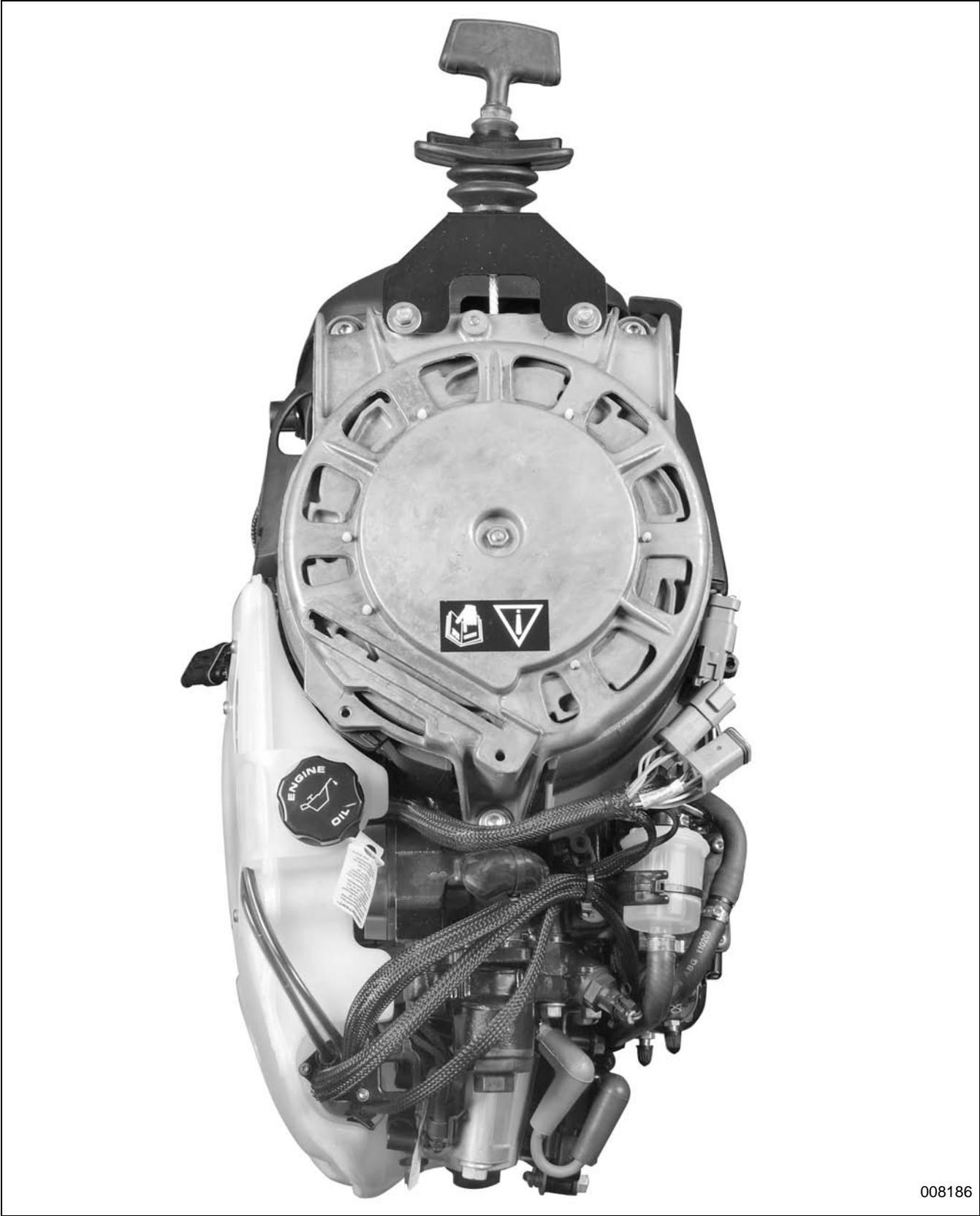

**10**

008186



**3-Cylinder Port – Hose Routings**

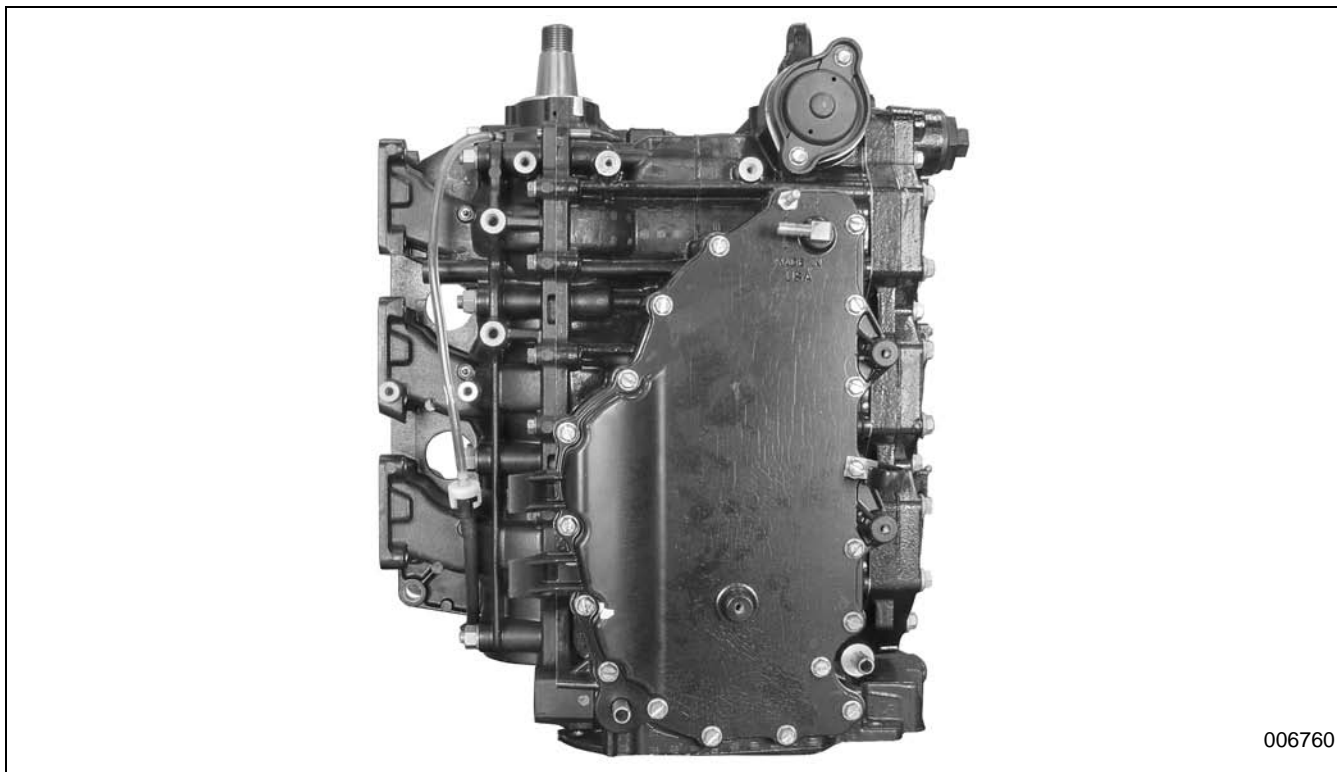

**3-Cylinder Starboard – Hose Routings**

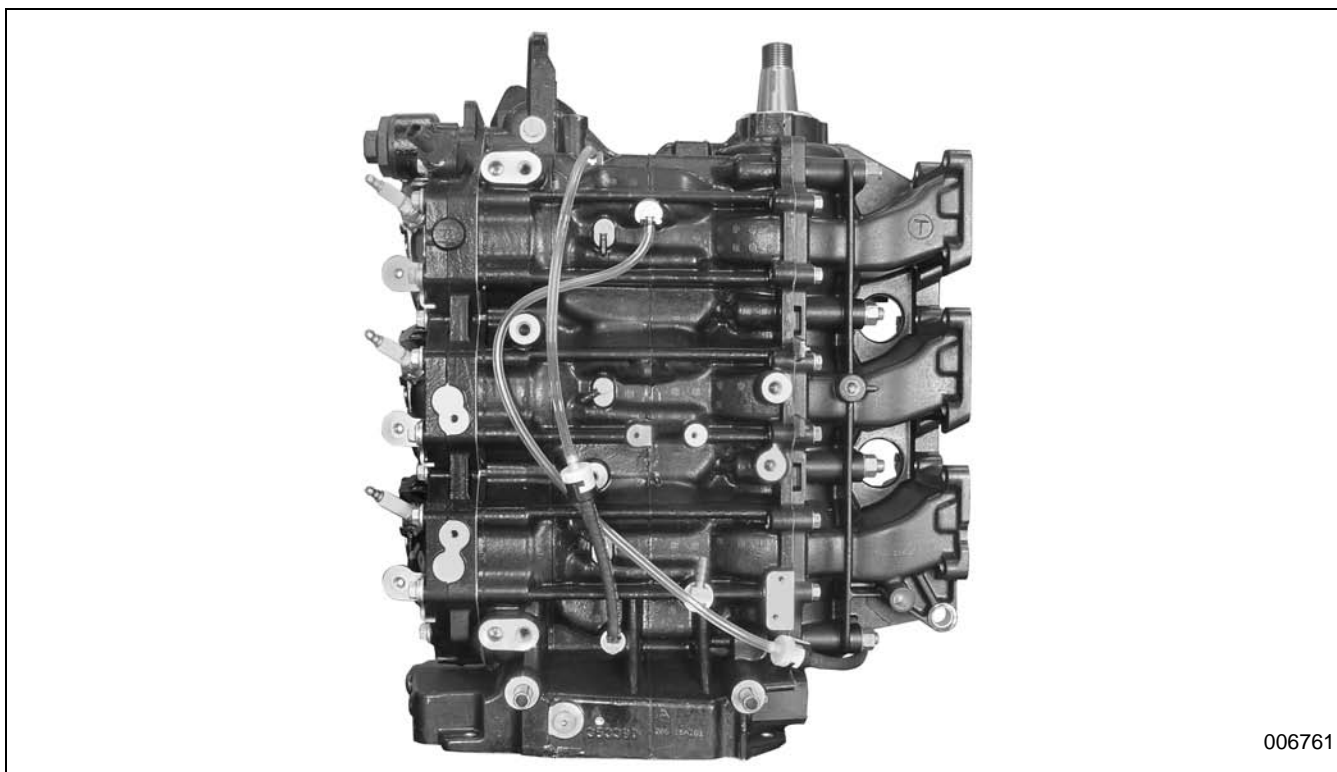



**3-Cylinder Port Dressed Powerhead**



**3-Cylinder Starboard Dressed Powerhead**

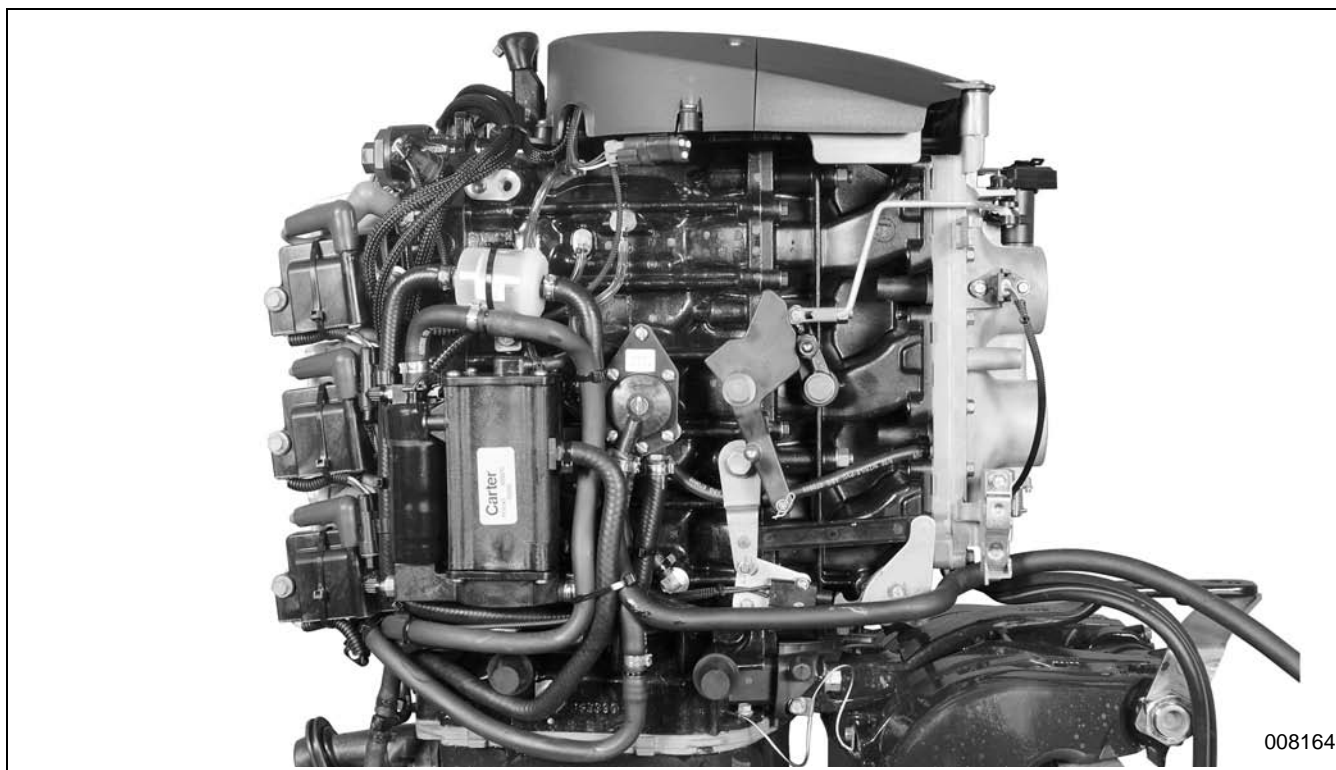

---

**POWERHEAD**  
**POWERHEAD VIEWS**

---

**3-Cylinder Front**

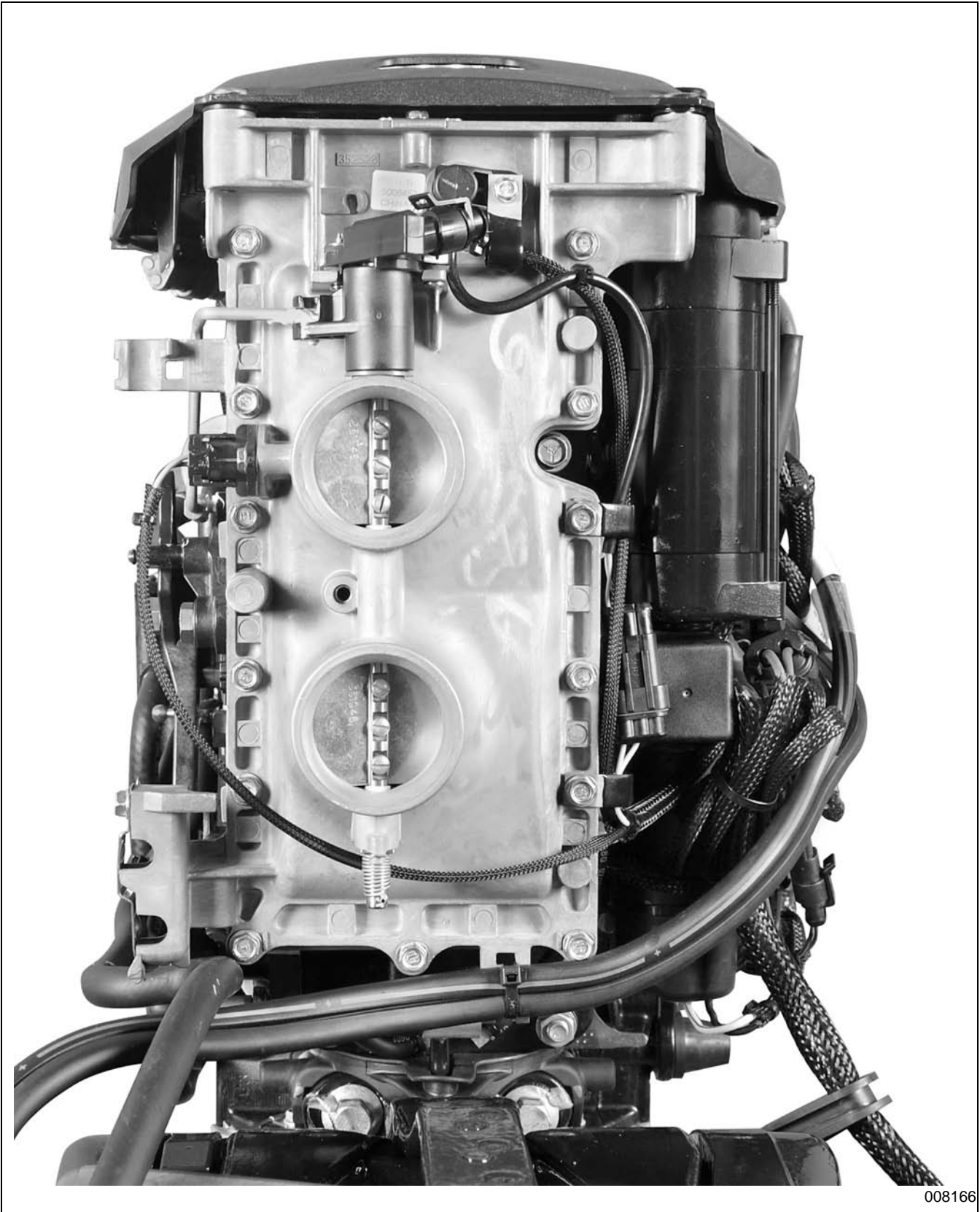

**3-Cylinder Rear**

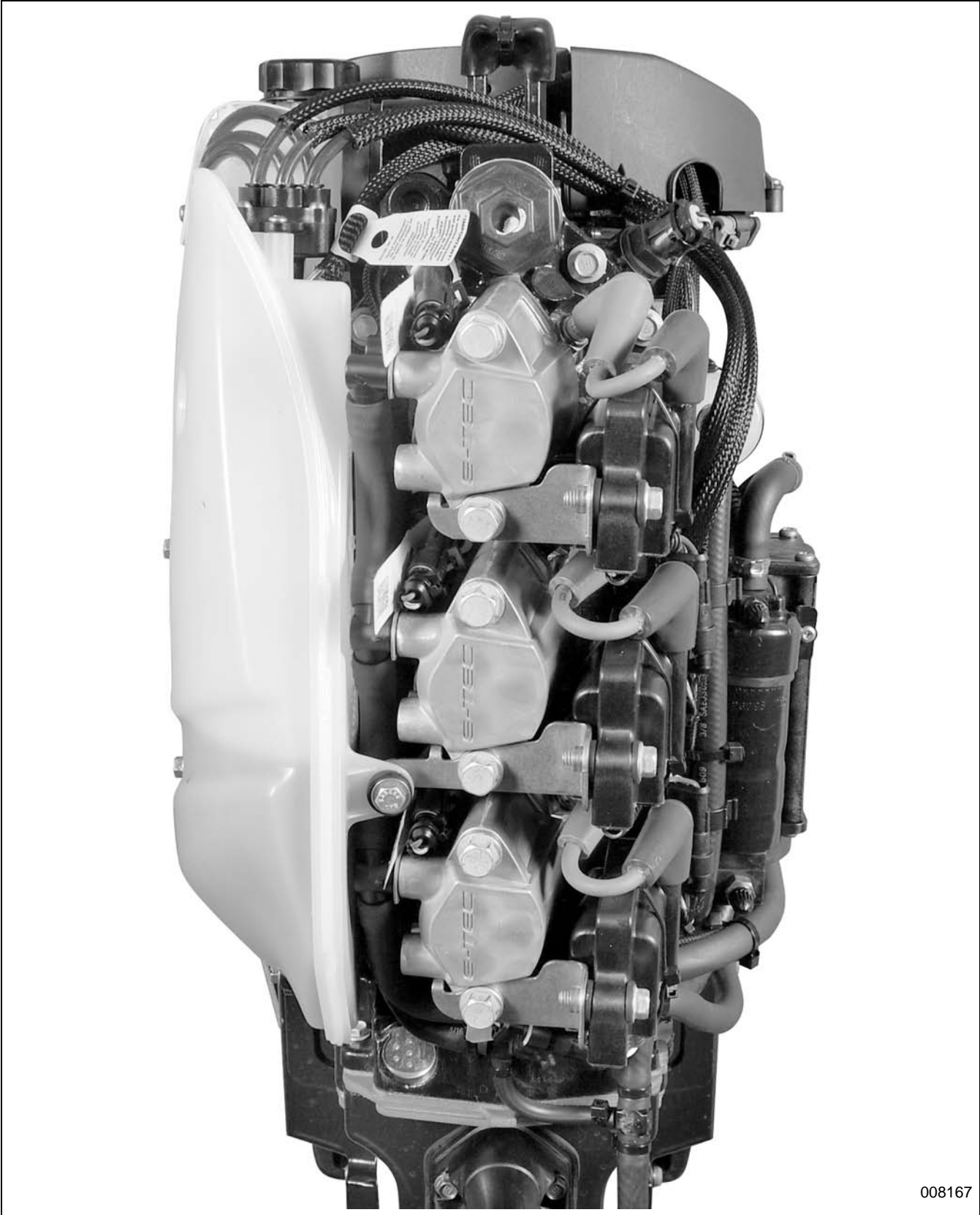

**10**

008167

---

**POWERHEAD**  
POWERHEAD VIEWS

---

**3-Cylinder Top**



008165

# MIDSECTION

## TABLE OF CONTENTS

SERVICE CHARTS .....	234
TILT TUBE, 75 – 90 HP .....	241
EXHAUST HOUSING, 40 – 65 HP .....	243
EXHAUST HOUSING REMOVAL .....	243
EXHAUST WATER VALVE (60–65 HP) .....	244
EXHAUST RELIEF MUFFLER .....	244
EXHAUST HOUSING INSTALLATION .....	245
EXHAUST HOUSING, 75 – 90 HP .....	246
EXHAUST HOUSING REMOVAL .....	246
LOWER MOUNT SERVICE .....	246
EXHAUST HOUSING INSTALLATION .....	247
EXHAUST HOUSING DISASSEMBLY .....	248
CLEANING AND INSPECTION .....	249
EXHAUST HOUSING ASSEMBLY .....	249
STERN BRACKET, 40 – 60 HP POWER TILT .....	251
STERN BRACKET DISASSEMBLY .....	251
STERN BRACKET ASSEMBLY .....	252
STERN BRACKET, 75 – 90 HP POWER TILT .....	253
STERN BRACKET DISASSEMBLY .....	253
STERN BRACKET ASSEMBLY .....	256
STERN BRACKET, 40 – 60 HP MANUAL TILT .....	258
CLAMP SCREW SERVICE .....	258
STERN BRACKET DISASSEMBLY .....	258
STERN BRACKET ASSEMBLY .....	261
TILT ASSIST CYLINDER .....	264
STERN BRACKET, 90 HP MANUAL TILT .....	265
STERN BRACKET DISASSEMBLY .....	265
STERN BRACKET ASSEMBLY .....	268
TILLER HANDLE SERVICE – STANDARD .....	271
REMOVAL .....	271
DISASSEMBLY .....	272
INSPECTION .....	273
ASSEMBLY .....	273
INSTALLATION .....	275
THROTTLE CABLE ADJUSTMENT .....	276
TILLER HANDLE SERVICE – LONG HANDLE .....	277
REMOVAL .....	277
DISASSEMBLY .....	278
INSPECTION .....	281
ASSEMBLY .....	281
INSTALLATION .....	285
CONTROL CABLE INSTALLATION .....	286

# SERVICE CHARTS

**EXHAUST HOUSING, 40 – 65 HP**

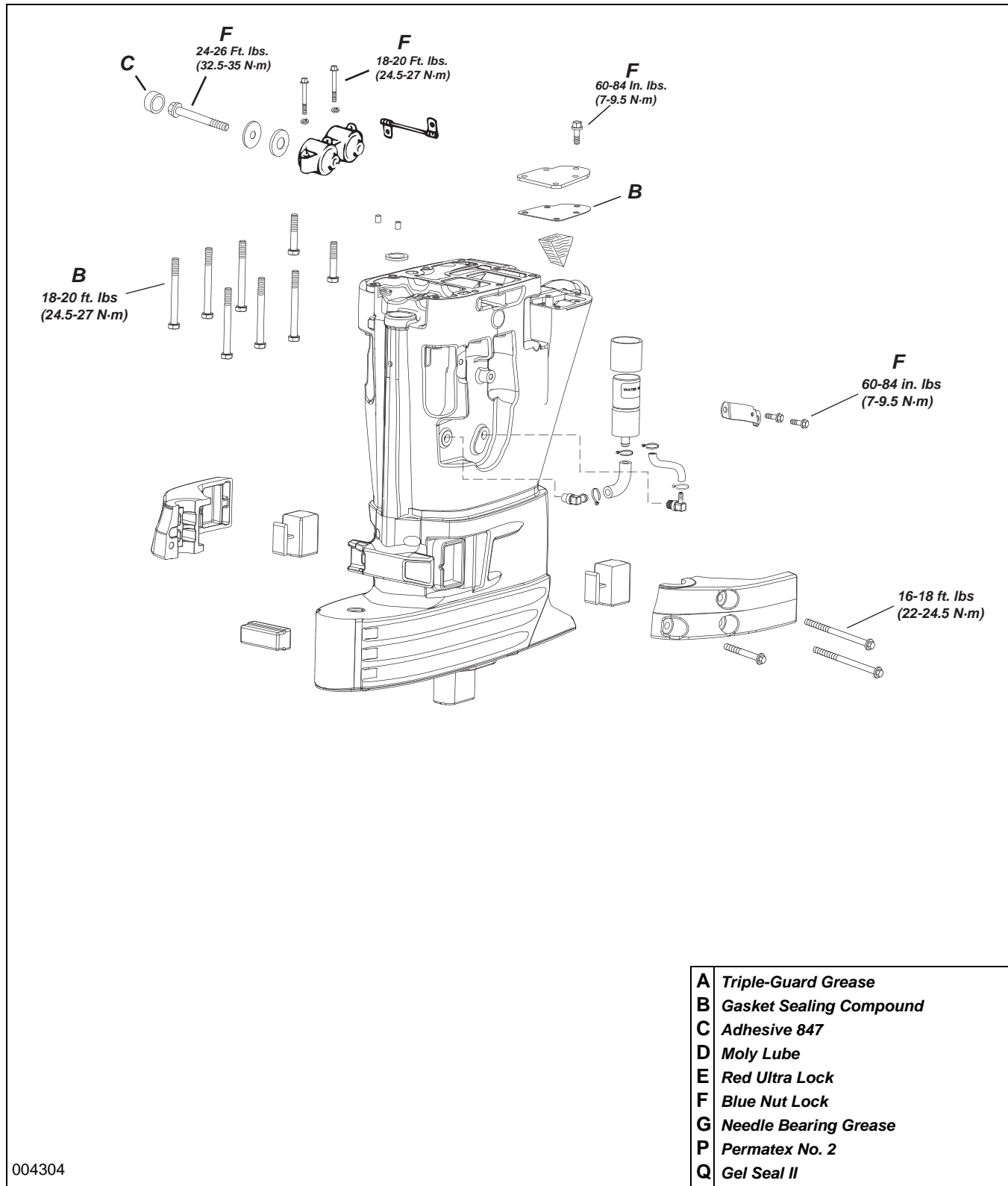

EXHAUST HOUSING, 75 – 90 HP

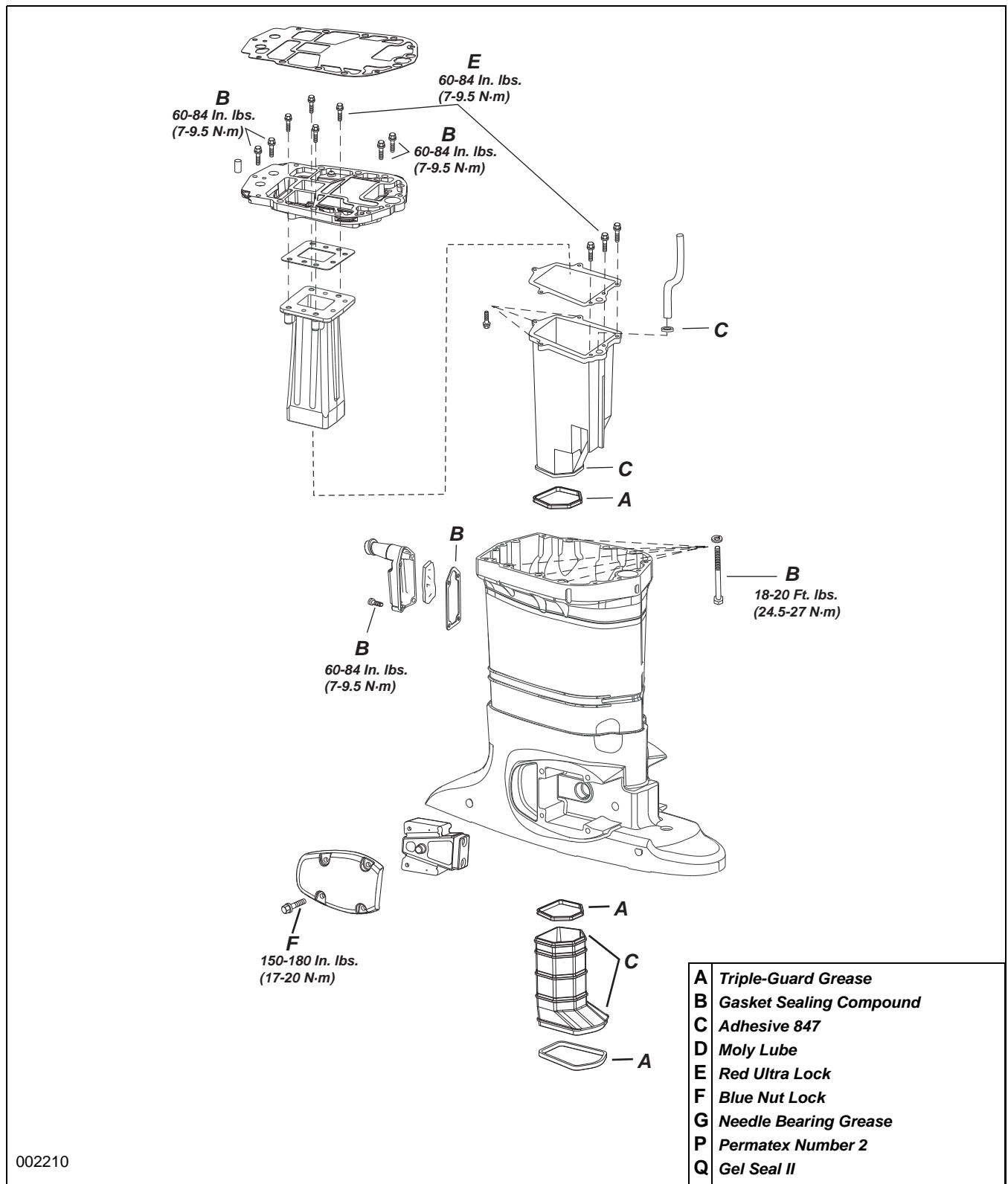

002210

**MIDSECTION**  
**SERVICE CHARTS**

**STERN BRACKET, 40 – 60 HP POWER TILT**

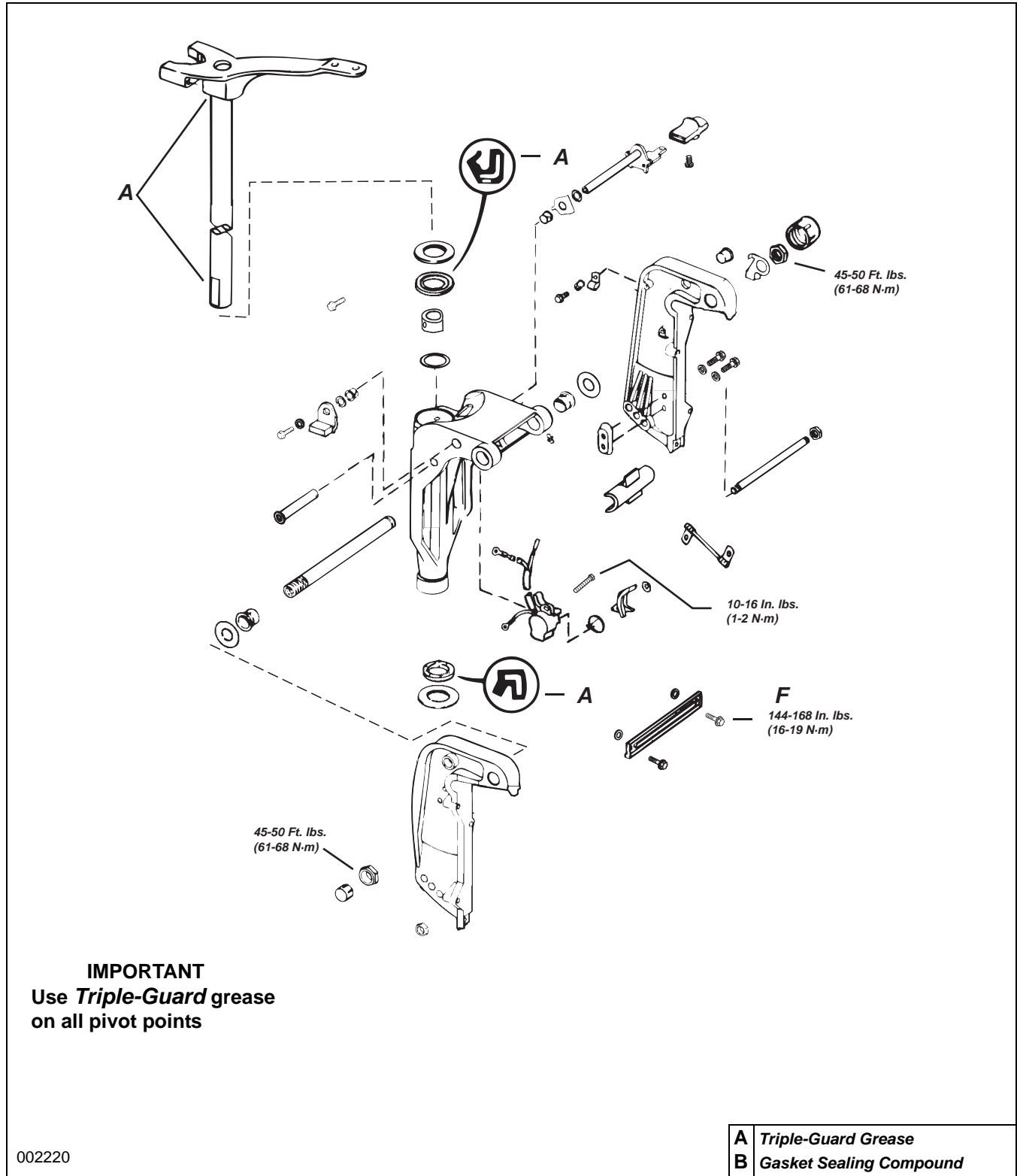

002220



**STERN BRACKET, 75 – 90 HP POWER TILT**

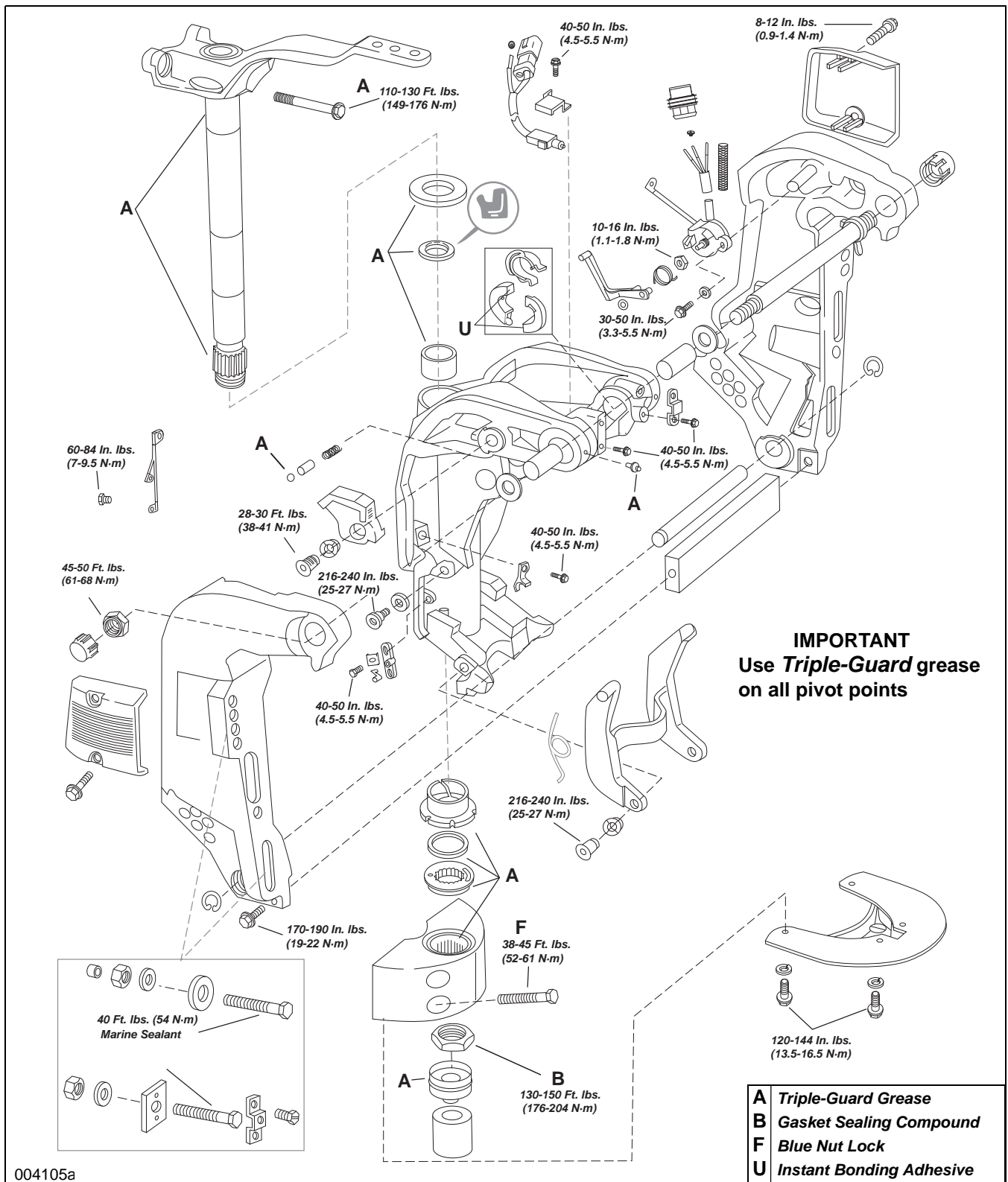

004105a

**MIDSECTION  
SERVICE CHARTS**

**STERN BRACKET, 40 – 65 HP MANUAL TILT**

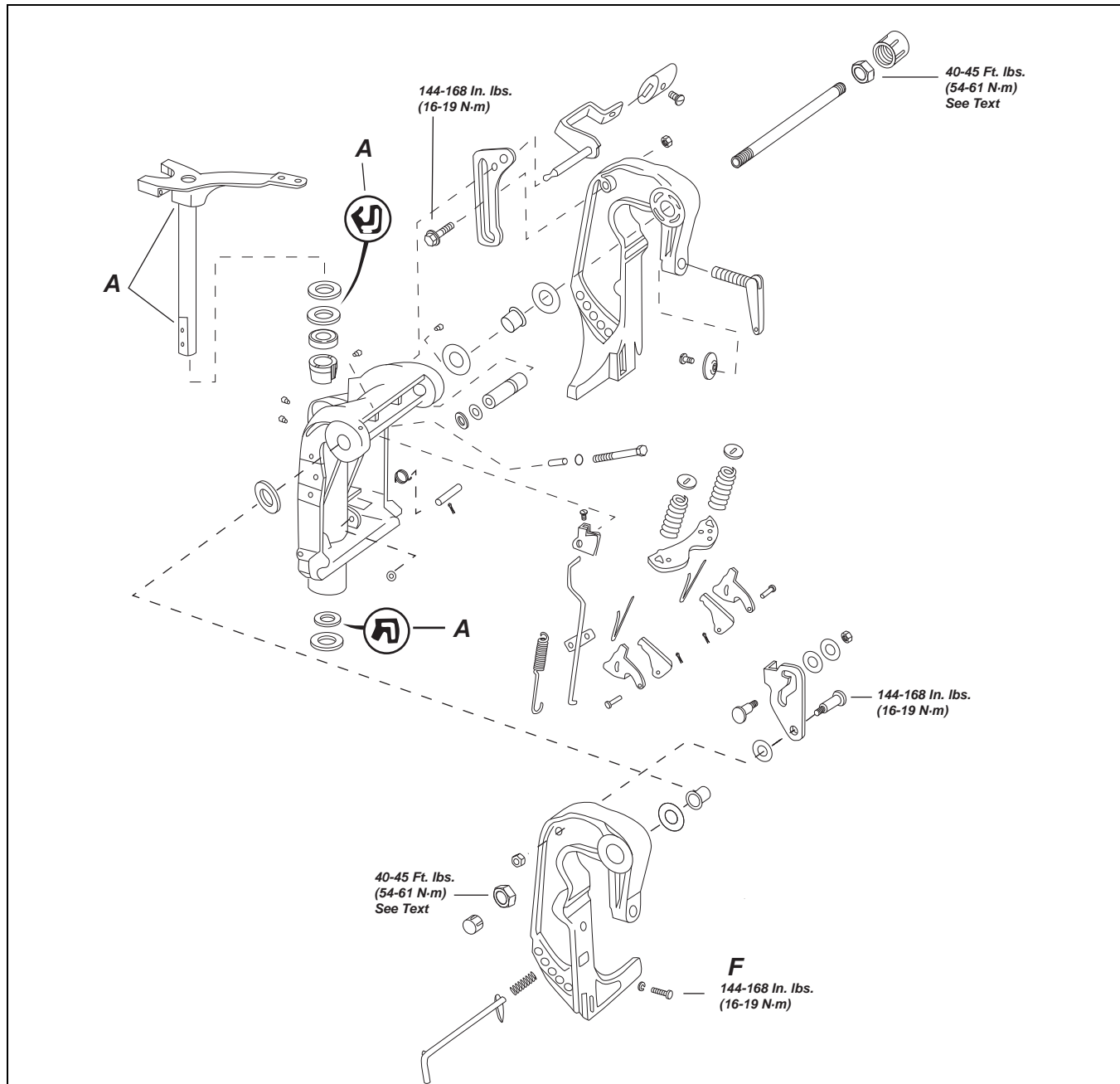

**IMPORTANT**  
Use *Triple-Guard* grease  
on all pivot points

- |          |                                |
|----------|--------------------------------|
| <b>A</b> | <i>Triple-Guard</i> Grease     |
| <b>B</b> | <i>Gasket Sealing Compound</i> |
| <b>C</b> | <i>Adhesive 847</i>            |
| <b>D</b> | <i>Moly Lube</i>               |
| <b>E</b> | <i>Red Ultra Lock</i>          |
| <b>F</b> | <i>Blue Nut Lock</i>           |
| <b>G</b> | <i>Needle Bearing Grease</i>   |
| <b>P</b> | <i>Permatex No. 2</i>          |
| <b>Q</b> | <i>Gel Seal II</i>             |

U02221



# MIDSECTION SERVICE CHARTS

## TILLER HANDLE (LONG)

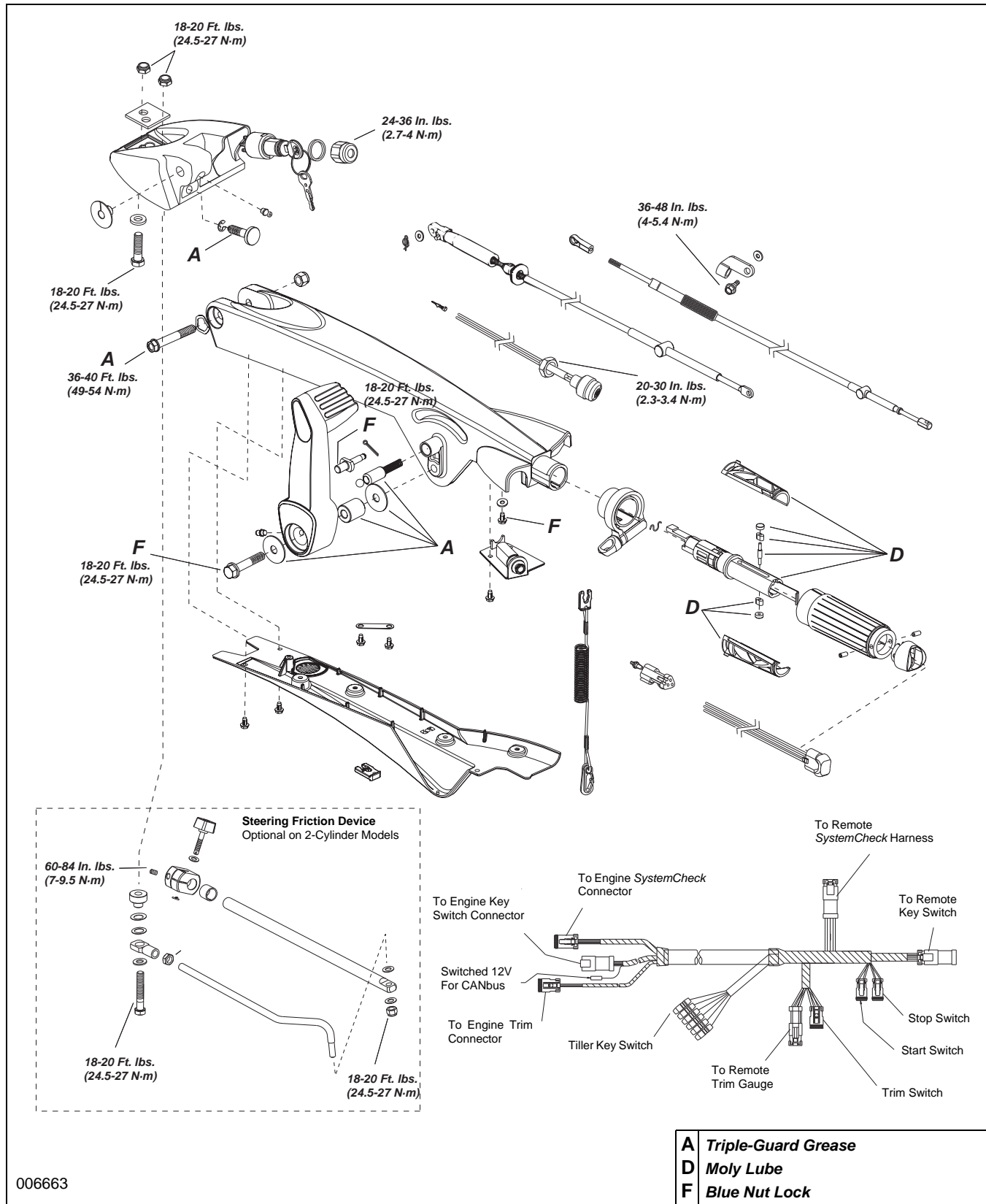

006663

## TILT TUBE, 75 – 90 HP

The tilt tube may be serviced without major disassembly of the outboard using Tilt Tube Service Kit, P/N 434523.

### Removal

**⚠ WARNING**

**Support the outboard with a suitable hoist.**

Pull the locking tabs on the tilt limit cam loose from the collar.

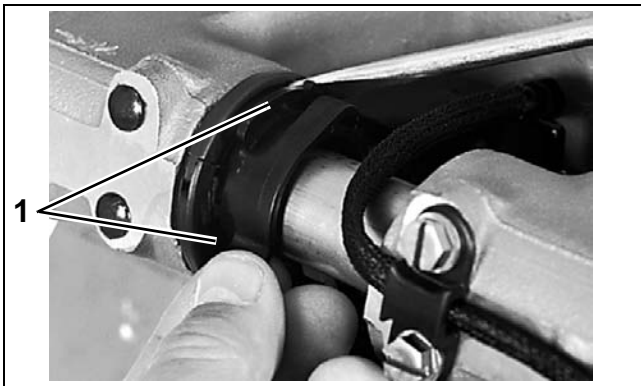

1. Locking tabs

30749

Remove the cam and collar from the tilt tube.



30748

Remove the nut from the starboard side.



30747

Thread the spacer from Tilt Tube Service Kit, P/N 434523, onto the starboard end of the tilt tube.

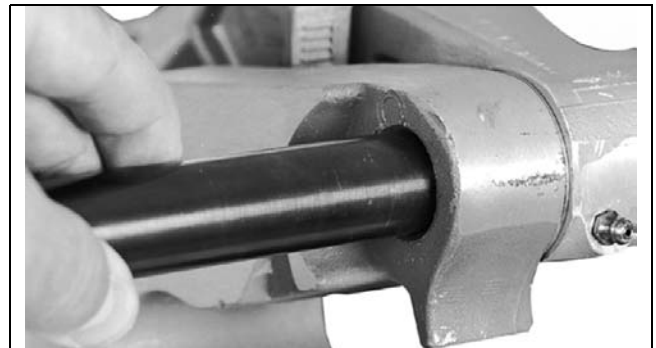

30746

Remove steering cable wiper nut from tilt tube. Thread the adapter from Tilt Tube Service Kit, P/N 434523, onto the port end of the tilt tube.

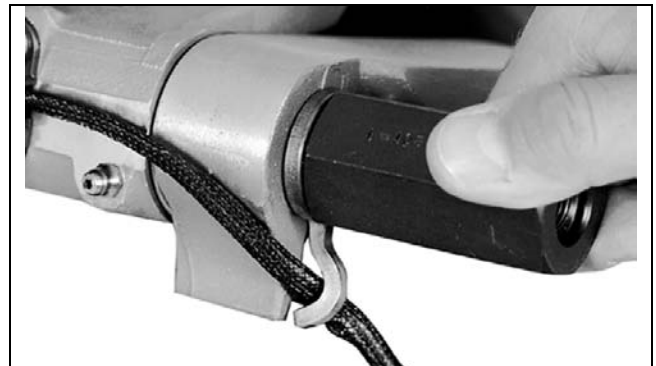

30745

## MIDSECTION

### TILT TUBE, 75 – 90 HP

Thread Slide Hammer, P/N 432128, into the adapter until at least 2 in. (51 mm) of thread are engaged.

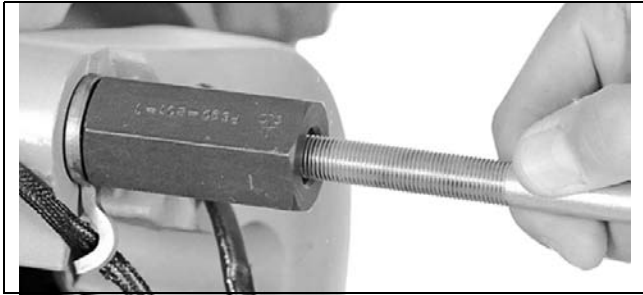

30744

Pull tilt tube from stern bracket with the slide hammer. When tilt tube clears the port stern bracket, remove tilt tube from the spacer.

## Installation

Thread starboard end of tilt tube into the spacer.

Thread the adapter onto port end of tilt tube.

Use a wood or leather mallet to tap the tilt tube into position.

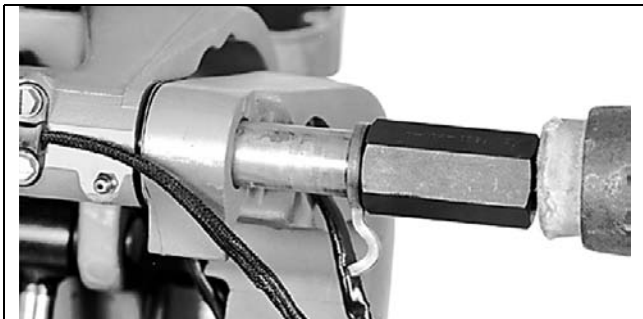

30743

Make sure the lock tab is in correct position.



1. Lock tab

30742

Install the starboard locknut.

## WARNING

Replace locknut if definite resistance is not felt.

Tighten starboard tilt tube nut to a torque of 45 to 50 ft. lbs. (61 to 68 N-m).

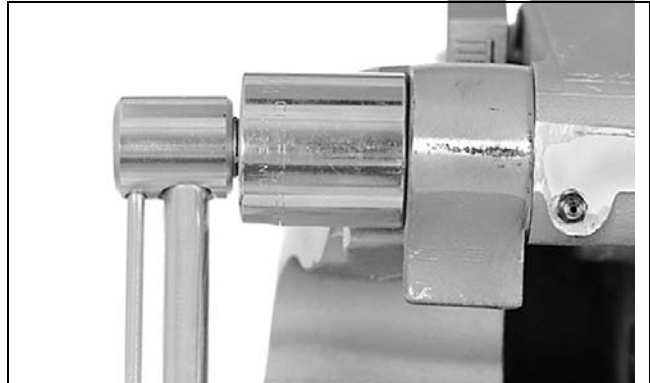

30741

Replace steering cable wiper nut on port end of tilt tube.

Apply one drop of instant bonding adhesive in receiving channels of tilt limit switch collar and install collar and tilt cam on tilt tube. Be sure locating tab on collar fits in hole on tilt tube.

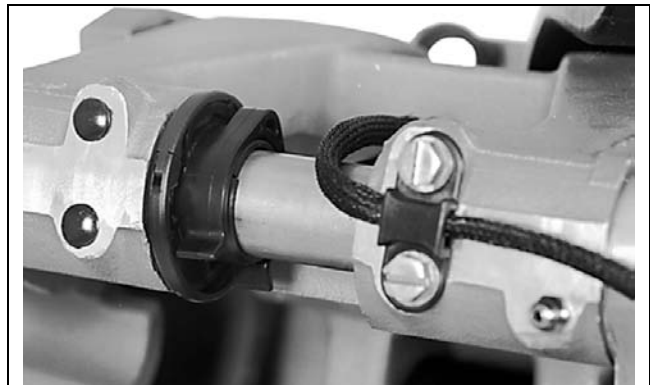

30750

## EXHAUST HOUSING, 40 – 65 HP

The exhaust housing contains no serviceable internal parts. The exhaust water valve and the exhaust relief muffler can both be serviced without removing the exhaust housing.

### Exhaust Housing Removal

Before removing the exhaust housing:

- Remove the gearcase. Refer to Gearcase **GEARCASE REMOVAL AND INSTALLATION** on p. 296.
- Remove the powerhead. Refer to Powerhead **POWERHEAD REMOVAL** on p. 190.

Remove the three lower mount cover screws.



17527

Separate lower mount covers from swivel bracket.

Check condition of the lower front mount and two lower side mounts.



1. Lower front mount

17526

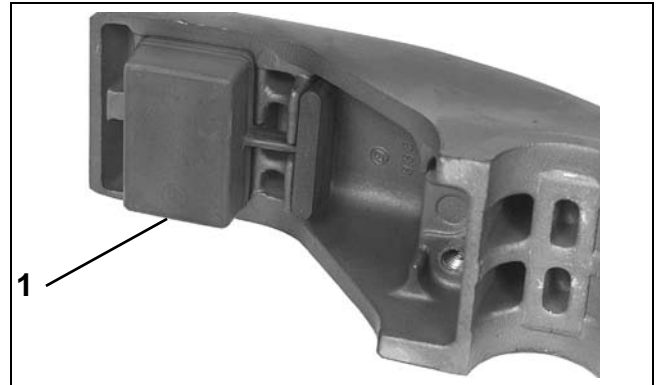

1. Lower side mount

17524

Remove the three upper mount to exhaust housing screws. Be sure to support exhaust housing so it does not fall.

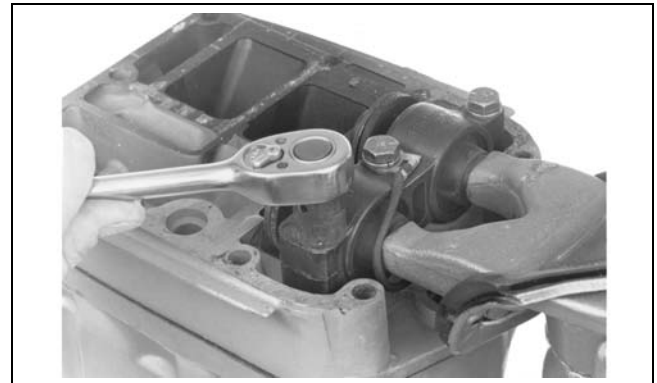

COA2943

Remove the exhaust housing.

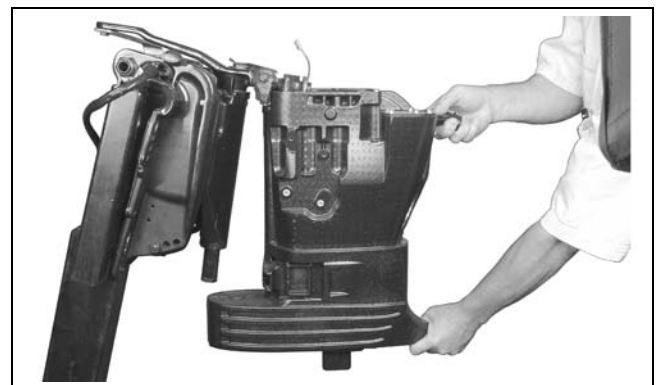

Exhaust Housing

005069



## MIDSECTION

### EXHAUST HOUSING, 40 – 65 HP

#### Exhaust Water Valve (60–65 HP)

Disconnect water valve electrical connector.

Remove screws and bracket holding valve to exhaust housing.

Remove tie straps and disconnect water valve hoses (3) from exhaust housing.

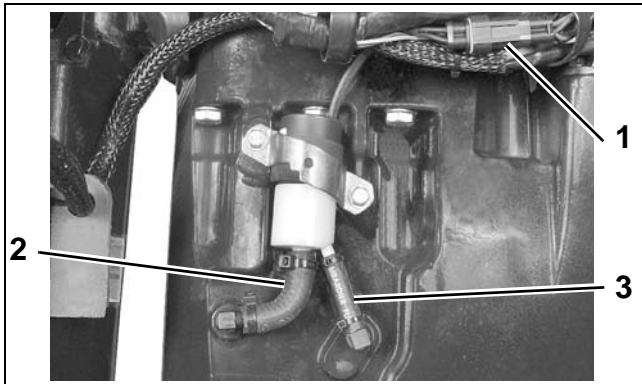

1. Electrical connector
2. Inlet hose
3. Outlet hose

004293

Check that all water passages are clear.

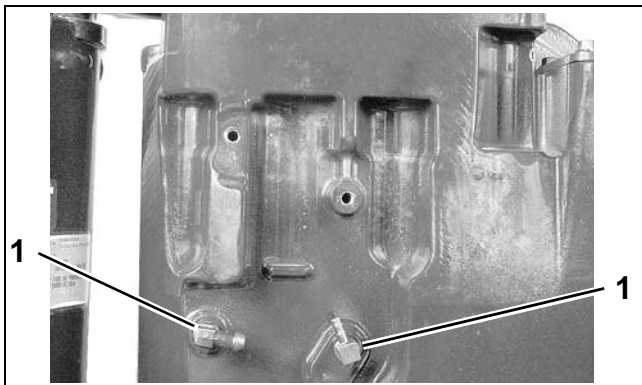

1. Fitting, water passage

004300

Install hoses to fittings on exhaust housing.

Place water valve and bracket in position.

Apply *Nut Lock* to screws, install and tighten 60 to 84 in. lbs. (7 to 9.5 N.m).

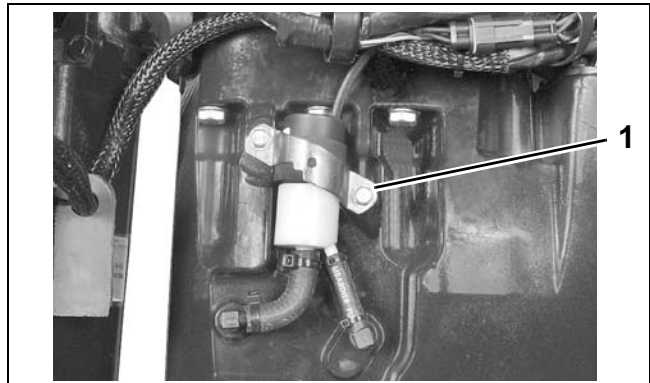

1. Exhaust water valve screws

004293

#### Exhaust Relief Muffler

Remove exhaust relief muffler cover to inspect filter element. Clean or replace as needed.

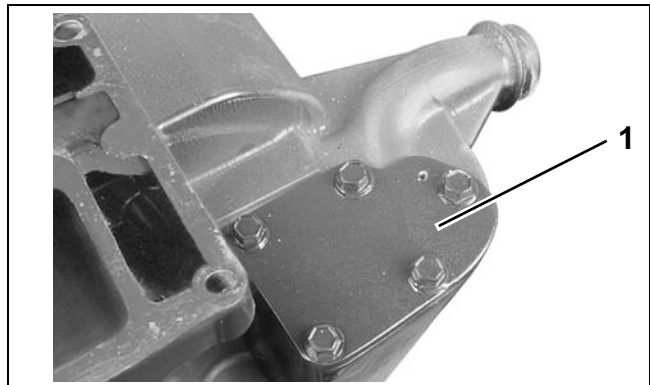

1. Exhaust relief muffler cover

004301

Apply *Gasket Sealing Compound* to cover gasket and install cover.

Apply *Nut Lock* to cover screws and tighten to a torque of 60 to 84 in. lbs. (7 to 9.5 N.m).



## Exhaust Housing Installation

Bring the exhaust housing into position with the stern bracket.

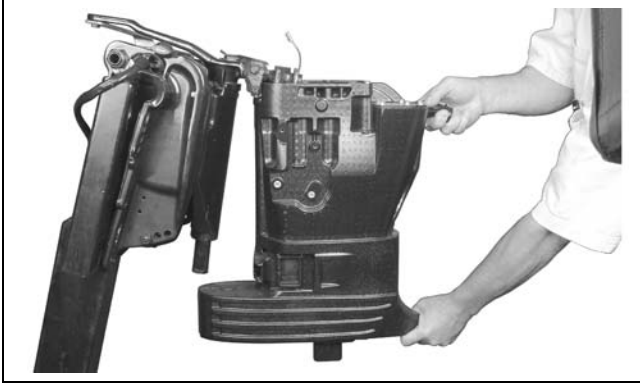

Exhaust Housing

005069

Apply *Nut Lock* to threads of the upper mount screws. Install the screws and place ground lead under the center screw. Tighten screws to a torque of 18 to 20 ft. lbs. (24 to 27 N·m).

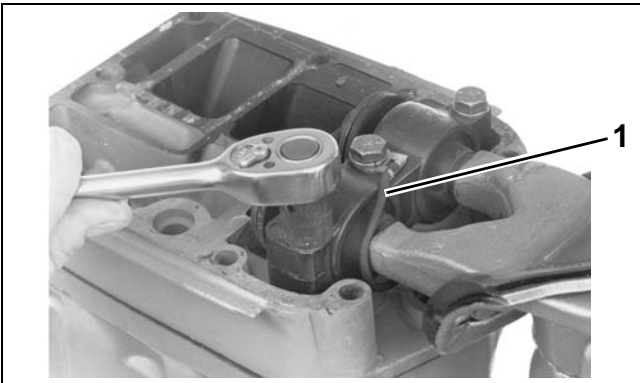

1. Ground lead

COA2943

Place lower thrust washer on the steering shaft and place the lower front mount into position.



1. Thrust washer  
2. Lower front mount

17526

Install lower side mount covers. Install and tighten the screws in stages to a torque of 16 to 18 ft. lbs. (22 to 24 N·m) following sequence shown.

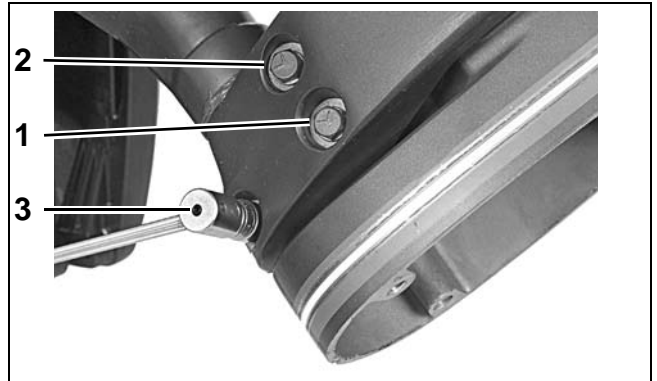

Torque sequence

17528

Install gearcase. Refer to Gearcase **GEARCASE REMOVAL AND INSTALLATION** on p. 296.

Install powerhead. Refer to Powerhead **POWER-HEAD INSTALLATION** on p. 216.

**MIDSECTION**  
EXHAUST HOUSING, 75 – 90 HP

# EXHAUST HOUSING, 75 – 90 HP

## Exhaust Housing Removal

Before removing the exhaust housing:

- Remove the gearcase. Refer to **GEARCASE REMOVAL AND INSTALLATION** on p. 296.
- Remove the powerhead. Refer to **POWER-HEAD REMOVAL** on p. 190.

Remove and discard four lower mount screws.



20" Models

23036



25" Models

32590

Remove the exhaust housing.



001986

## Lower Mount Service

Remove lower mount covers and inspect the lower mounts.

If replacement is necessary, lubricate mount with soapy water and carefully pry at both ends to remove.



001971

If removed, coat the lower mounts with soapy water and press into the exhaust housing with the "OUTSIDE" mark facing outward.

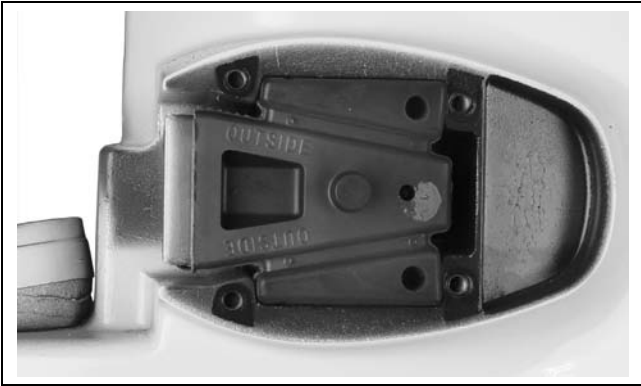

001970

Install the mount covers. Apply *Nut Lock* to screws, install washers and screws, and tighten to a torque of 150 to 180 in. lbs. (17 to 20 N·m).



001972

## Exhaust Housing Installation

Bring the exhaust housing into position with the stern bracket.

Install four **new** lower mount screws with lock-patch. Tighten screws to a torque of 38 to 45 ft. lbs. (51 to 61 N·m).



20" Models

23036

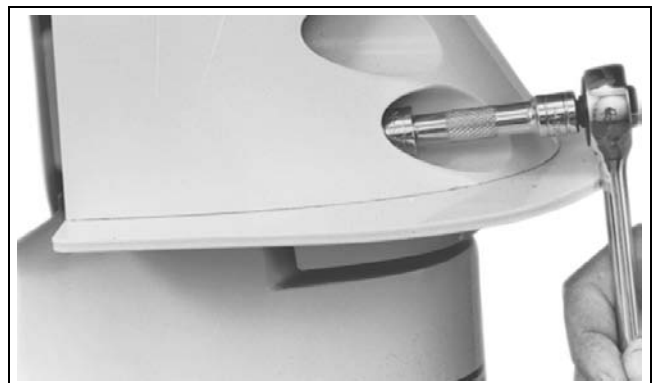

25" Models

32590

Install gearcase. Refer to **GEARCASE REMOVAL AND INSTALLATION** on p. 296.

Install powerhead. Refer to **POWERHEAD INSTALLATION** on p. 216.

**MIDSECTION**  
**EXHAUST HOUSING, 75 – 90 HP**

**Exhaust Housing Disassembly**

Remove the front and rear screws retaining the adapter/inner exhaust housing to the exhaust housing.



1. Adapter retaining screws 001981

Lift the adapter/inner exhaust housing out of the exhaust housing.

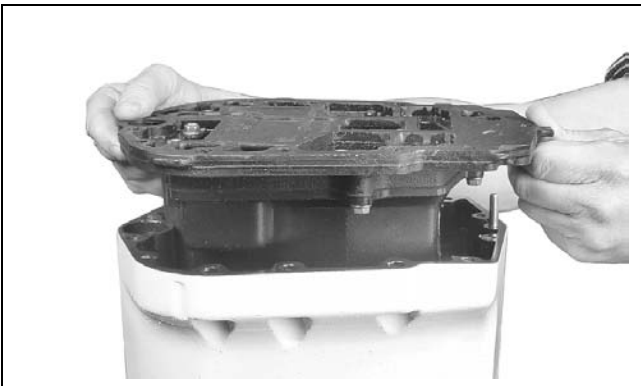

001980

Remove the three upper screws and three lower screws securing the inner exhaust housing to the adapter housing.

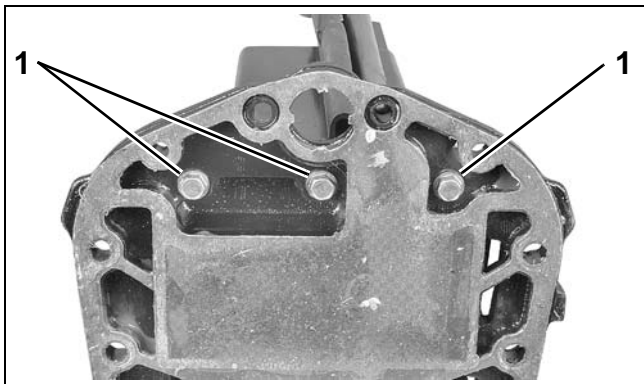

1. Upper inner exhaust housing screws 001975

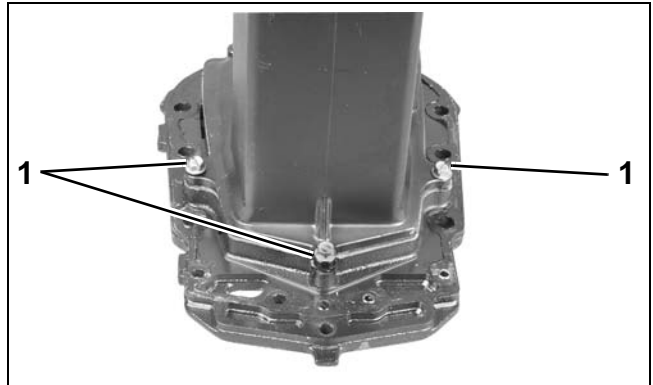

1. Lower inner exhaust housing screws 001974

Remove the water tube from the inner exhaust housing. Discard water tube grommet.



1. Water tube grommet 001984

Remove the seal from the bottom flange of the inner exhaust housing.

Remove the four screws securing the exhaust megaphone to the adapter housing.

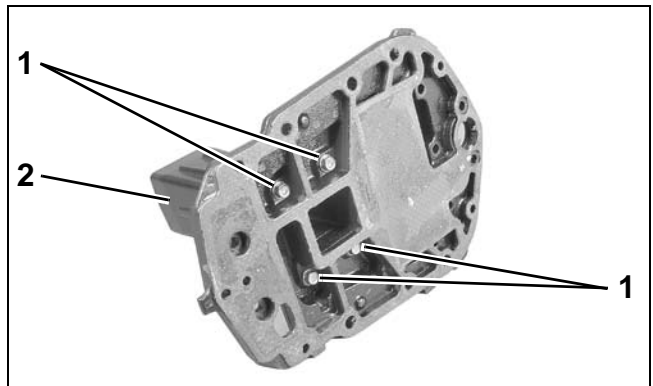

1. Adapter to megaphone screws 001976  
2. Exhaust megaphone

## Cleaning and Inspection

### ⚠ WARNING

**Wear safety glasses to avoid personal injury, and set compressed air to less than 25 psi (172 kPa).**

Clean all parts with parts cleaning solvent and dry with compressed air. All nut and screw threads coated with thread locking material must be thoroughly cleaned before assembly. When using a thread locking product, be sure to prime the threads with *Locquic Primer*.

Examine the upper and lower thrust mounts, and replace if deteriorated or damaged.

Before checking the exhaust housing for distortion, thoroughly clean the top and bottom mating surfaces and remove all sealer and corrosion.

Check the exhaust housing for distortion. Place the housing on a surface plate. Use a dial indicator to check flatness by measuring the run-out on the top edge of housing. The maximum allowable run-out is 0.009 in. (0.228 mm). If you do not have access to a dial indicator and surface plate, seek the services of a machine shop. **DO NOT** attempt to straighten a distorted housing; replace it.

**IMPORTANT:** A distorted exhaust housing will cause the upper driveshaft splines to wear excessively and will damage the crankshaft splines.

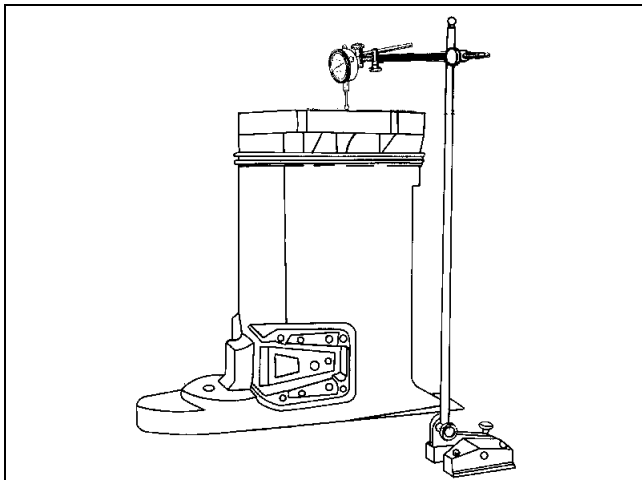

DR2223

Inspect the water tube for obstructions or kinks, which may restrict water flow.

## Exhaust Housing Assembly

Place a new gasket between the exhaust megaphone and adapter housing. Apply *Ultra Lock* to the threads of the screws and tighten to a torque of 60 to 84 in. lbs. (7 to 9.5 N·m).

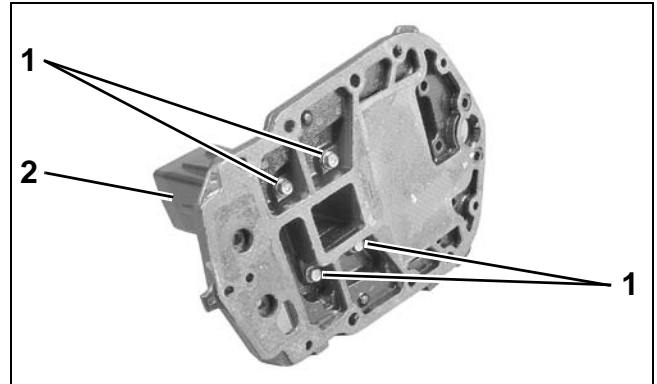

1. Adapter to megaphone screws
2. Exhaust megaphone

001976

Place a new grommet on the water tube and coat the outside edge with *Adhesive 847*.

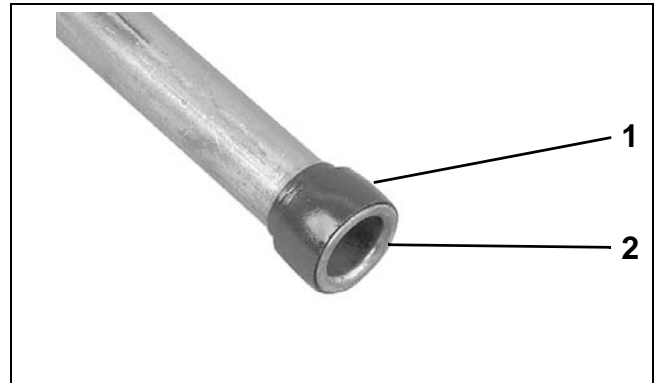

1. Water tube grommet
2. Flared end of water tube

001977

## MIDSECTION

### EXHAUST HOUSING, 75 – 90 HP

Install the water tube through the top of the inner exhaust housing and align as shown:

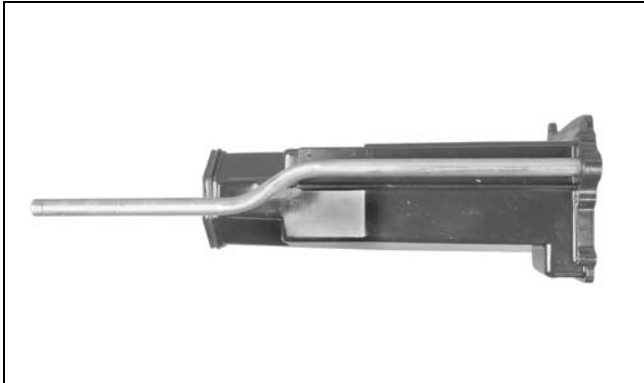

001982

Place a new gasket between the inner exhaust housing and the adapter housing. Apply *Ultra Lock* to the screws. Install the three lower screws and three upper screws and tighten to a torque of 60 to 84 in. lbs. (7 to 9.5 N·m).

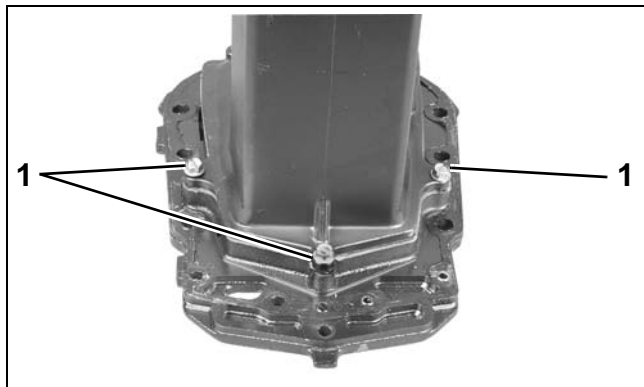

1. Lower inner exhaust housing screws

001974

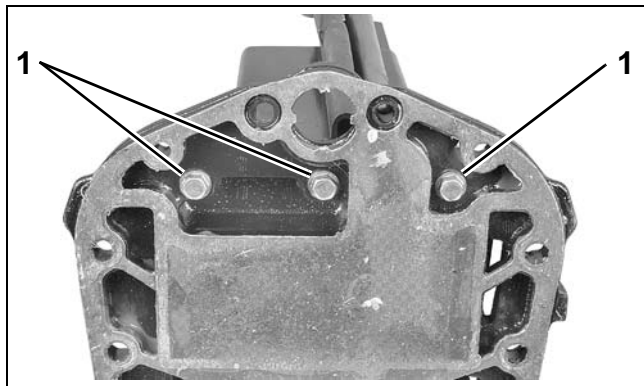

1. Upper inner exhaust housing screws

001975

Apply *Adhesive 847* to the bottom flange of the inner exhaust housing. Install a new seal. Apply *Triple-Guard* grease to outer seal surface.



1. Seal  
2. Bottom flange

001973

Clean and degrease the adapter housing and outer exhaust housing mating surfaces with *Cleaning Solvent*. Apply *Gel-Seal II* sealant to the adapter flange of the exhaust housing.

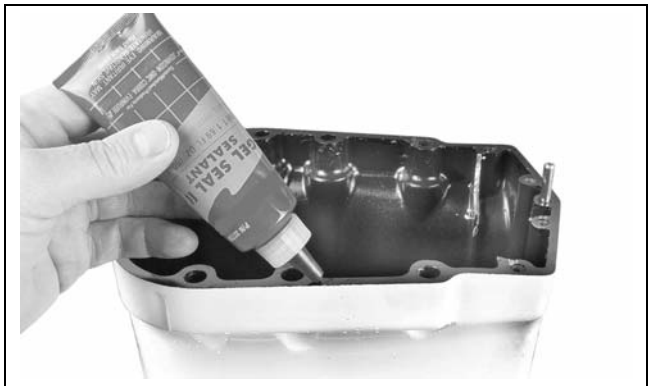

001983

Place the adapter/inner exhaust housing into the exhaust housing. Guide the water tube through

the hole in the outer housing and the alignment pin into the adapter housing.

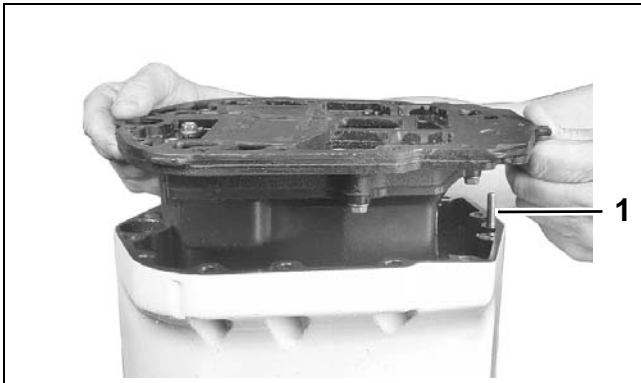

1. Alignment pin

001980

Apply *Gasket Sealing Compound* to threads of the four retaining screws and tighten to a torque of 60 to 84 in. lbs. (7 to 9.5 N-m).



1. Adapter retaining screws

001981

## STERN BRACKET, 40 – 60 HP Power Tilt

### Stern Bracket Disassembly

Remove the bumpers from the upper mount retaining screws. Remove the screws, upper mount, and ground lead from the bracket.

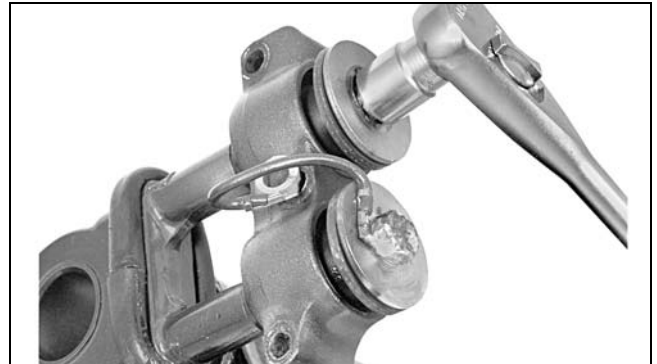

17505

Pull the steering arm out of the swivel bracket. Use an appropriate tool to pry the upper and lower seals from the swivel bracket.

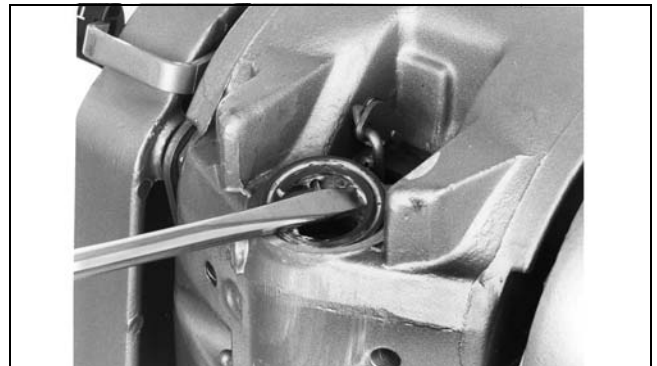

COA2957



COA2958

## MIDSECTION

### STERN BRACKET, 40 – 60 HP POWER TILT

To separate the swivel bracket from the stern bracket, remove one tilt tube nut.

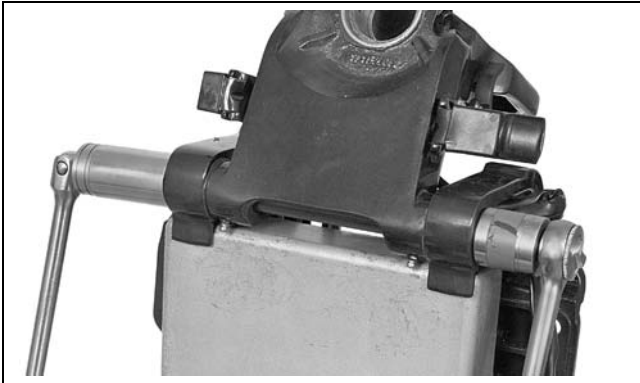

17544

Remove the tie bar to separate the two stern brackets.



17541

Check the condition of the anode. Replace the anode if it has been reduced to two-thirds its original size.



17551

## Stern Bracket Assembly

Assemble the tie bar to the stern brackets. Place the ground lead and starwasher between the port stern bracket and tie bar.



17540

Lubricate the swivel bracket bushings with *Triple-Guard* grease. Place the bushings in the swivel bracket.

Position the swivel bracket between the stern brackets. Place a thrust washer between each of the stern brackets and the swivel bracket.



17553

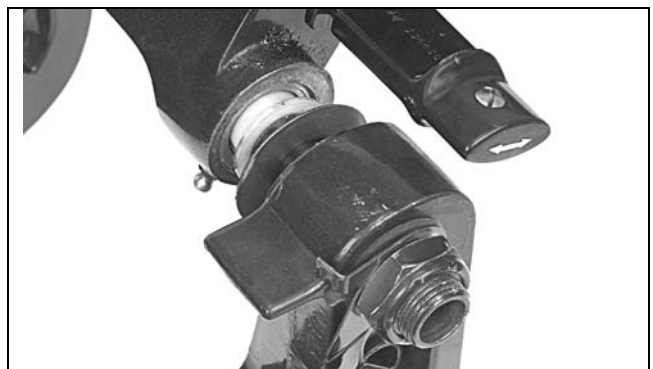

17552



Install the tilt tube. Tighten the tilt tube nuts 40 to 45 ft. lbs. (54 to 61 N·m), then back off 1/8 to 1/4 turn.

Apply *Nut Lock* to threads of the upper mount to steering arm screws. Install the mount and tighten the screws 24 to 26 ft. lbs. (32.5 to 35 N·m). Make sure to place the ground lead under the starboard screw.



17506

Apply a liberal amount of *Adhesive 847* to heads of the upper mount screws.



17507

Place the bumpers on the upper mount screws.



17509

## STERN BRACKET, 75 – 90 HP Power Tilt

### Stern Bracket Disassembly

Before servicing the stern bracket:

- Remove gearcase. Refer to **GEARCASE REMOVAL AND INSTALLATION** on p. 296.
- Remove powerhead. Refer to **POWERHEAD REMOVAL** on p. 190.
- Remove exhaust housing. Refer to **Exhaust Housing Removal** on p. 246.
- Remove power trim/tilt unit. Refer to **TRIM AND TILT REPLACEMENT** on p. 352.

Remove and discard steering shaft locknut.

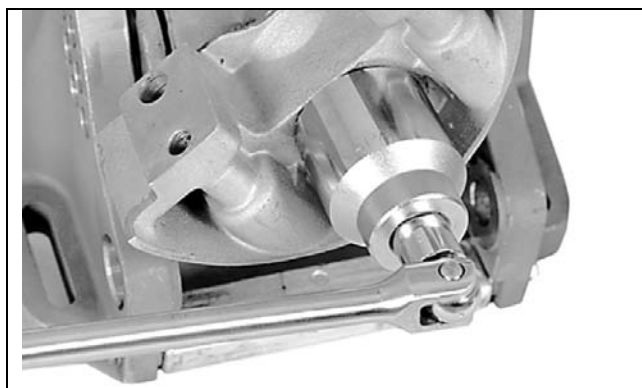

30738

Remove the lower mount bracket and keeper.



Lower mount bracket – 20" Models

30736

## MIDSECTION

### STERN BRACKET, 75 – 90 HP POWER TILT

Remove the steering shaft and thrust washer. It may be necessary to tap the steering shaft out using a wood dowel and mallet.

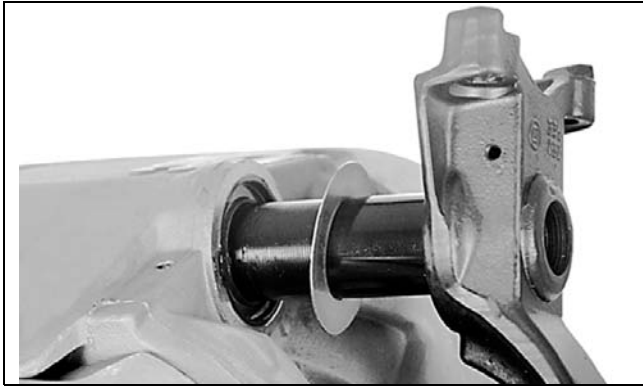

30735

Pry out upper and lower steering shaft seals and discard. Remove the upper and lower steering shaft bushings.

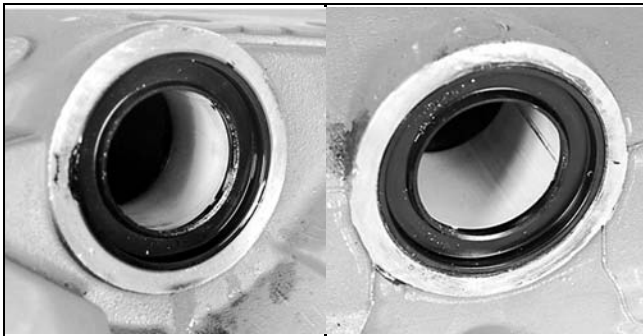

30765 / 30764

Remove the tilt tube. Refer to **TILT TUBE, 75 – 90 HP** on p. 241.

Remove the two tilt tube washers.

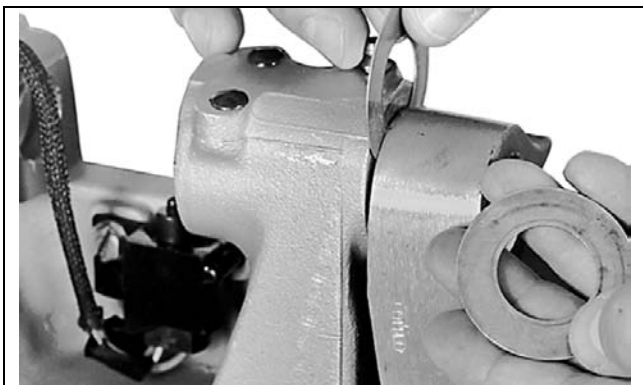

30763

Remove the anode.



1. Anode

30762

Remove the swivel bracket. Inspect and, if necessary, replace the tilt tube bushings.

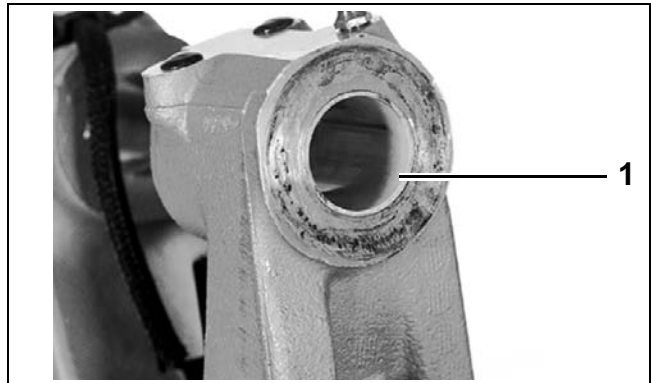

1. Tilt tube bushing

30761

Remove the trim sender unit from the port stern bracket and pull its wires through the braided tube.

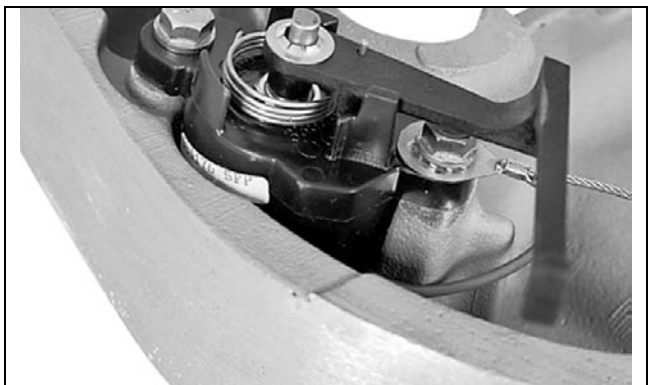

30760

Remove the tilt limit switch and retainer from the swivel bracket.

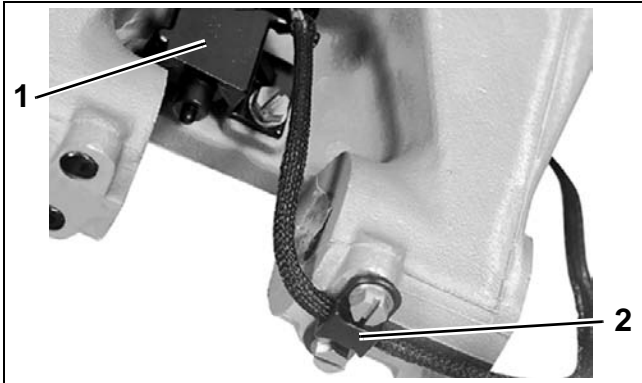

1. Tilt limit switch  
2. Retainer  
30758

Remove the two trim rod rollers from the swivel bracket.

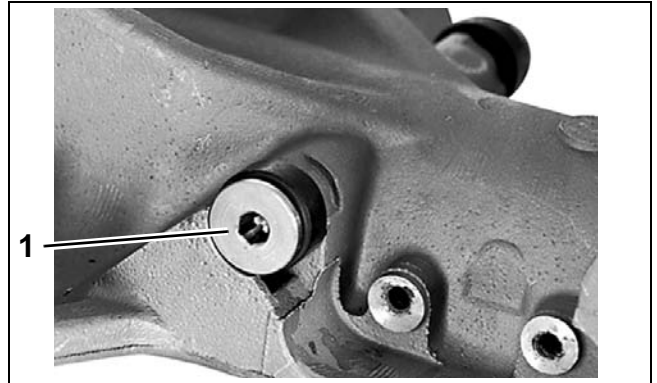

1. Trim rod roller  
30754

Disconnect the trail lock spring and remove it from the swivel bracket. Remove trail arm retainer.

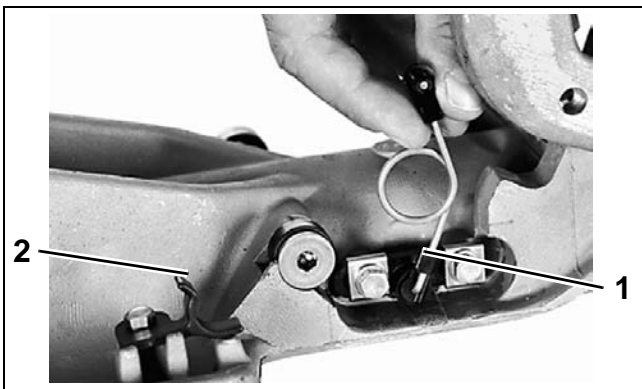

1. Trail lock spring  
2. Trail arm retainer  
30756

Remove the tilt support and bushing from the swivel bracket and inspect the detent roller and spring.

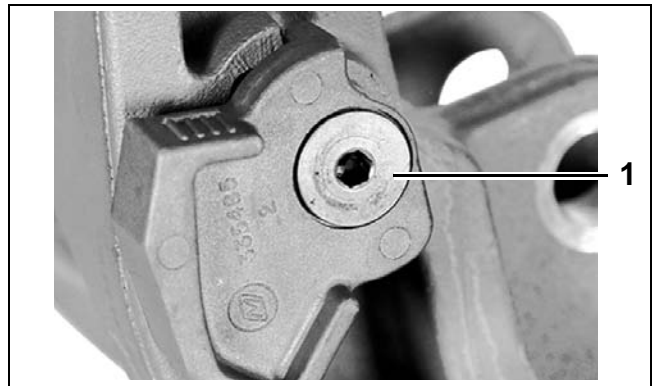

1. Tilt support bushing  
30753

Remove the trail lock arm and bushings from the swivel bracket.

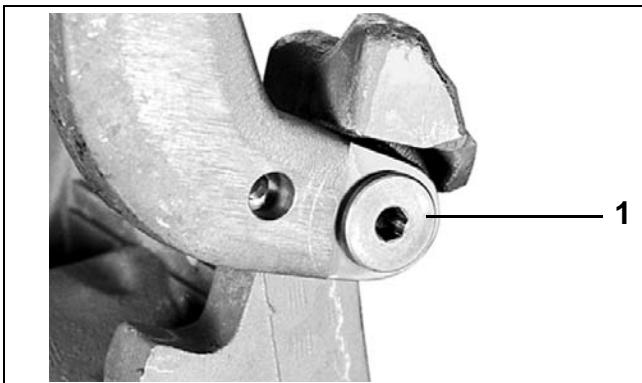

1. Trail lock bushing  
30755

## MIDSECTION

### STERN BRACKET, 75 – 90 HP POWER TILT

#### Stern Bracket Assembly

**IMPORTANT:** Before proceeding, make sure all components have been thoroughly cleaned. Replace any seals that have been removed. Inspect all thrust washers and bushings for evidence of deterioration.

Install the detent roller and spring and the tilt support with bushing in the swivel bracket. Tighten bushing to a torque of 28 to 30 ft. lbs. (38 to 41 N·m).



30752

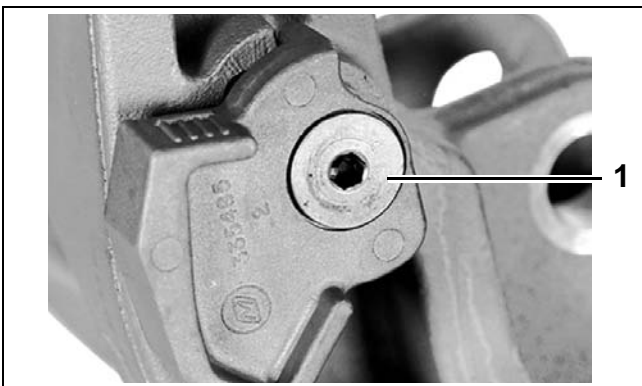

1. Tilt support bushing

30753

Install the two trim rod rollers on the swivel bracket. Tighten to a torque of 216 to 240 in. lbs. (25 to 27 N·m).

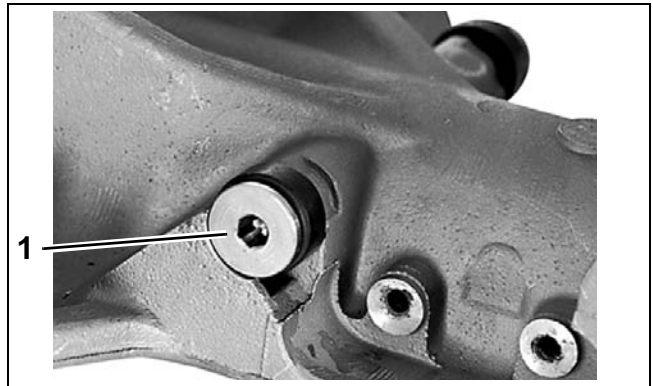

1. Trim rod roller

30754

Install the trail lock and bushings in the swivel bracket. Tighten to a torque of 216 to 240 in. lbs. (25 to 27 N·m).

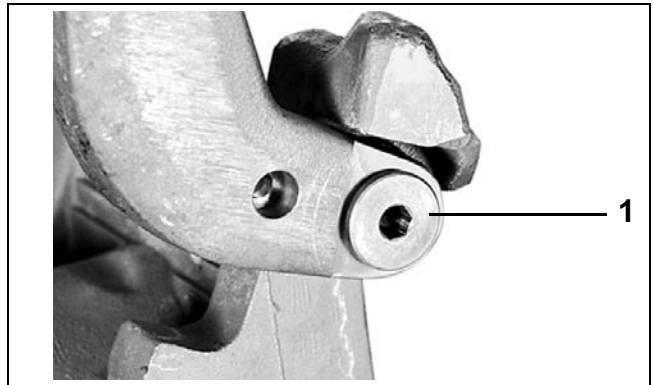

1. Trail lock bushing

30755

Install the trail lock spring in the swivel bracket and connect the spring to the trail lock.

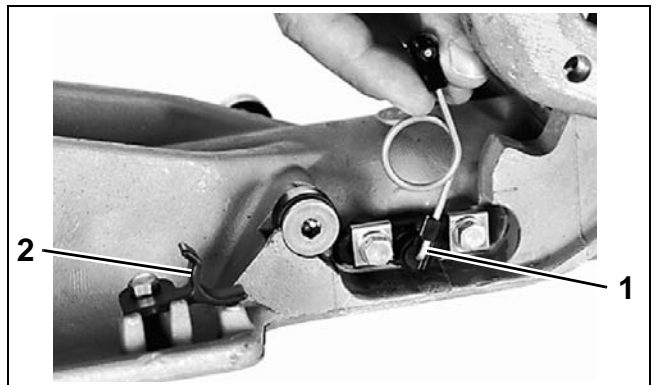

1. Trail lock spring  
2. Trail arm retainer

30756

Install the tilt limit switch and retainer on the swivel bracket. Tighten screws to a torque of 40 to 50 in. lbs. (4.5 to 5.5 N·m).

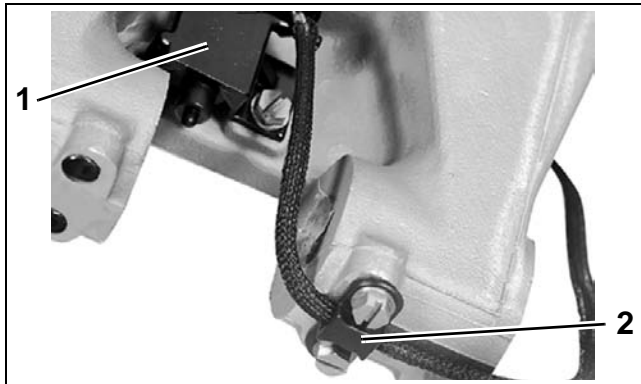

1. Tilt limit switch
2. Retainer

30758

Route the trim sender wires through the braided tube, and install the sender unit in the port stern bracket.

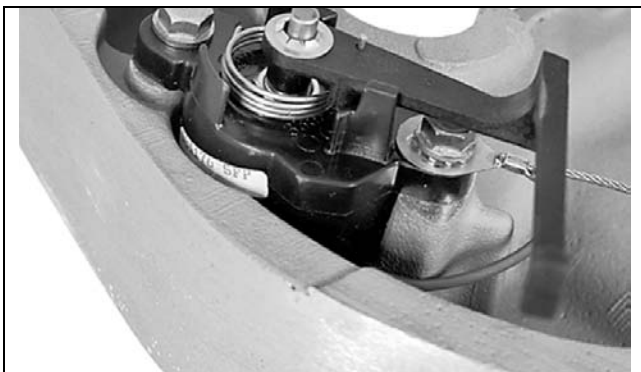

30760

Install the upper and lower steering shaft bushings and new seals in the swivel bracket. Both seal lips face out.

- Coat the outside surfaces of seals with *Gasket Sealing Compound*.

- Coat the bushings and seal lips with *Triple-Guard* grease.

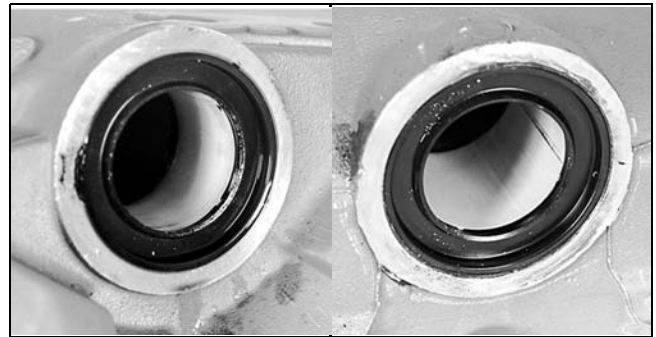

30765 / 30764

Coat tilt tube bushings with *Triple-Guard* grease and, if removed, install them in the swivel bracket.

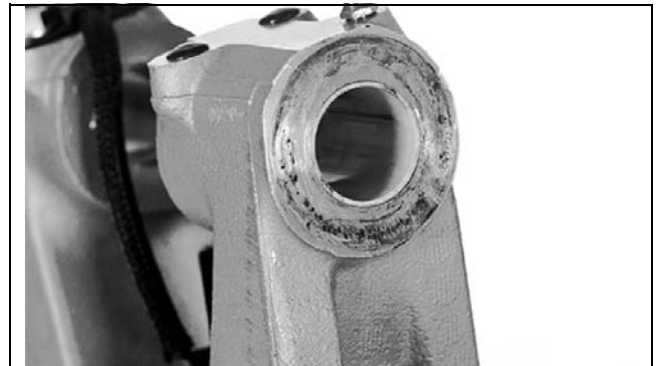

30761

Place the swivel bracket between the stern brackets and install the anode.

Install the tilt tube and tilt limit cam. Refer to **TILT TUBE, 75 – 90 HP** on p. 241.

Install the steering shaft and thrust washer.

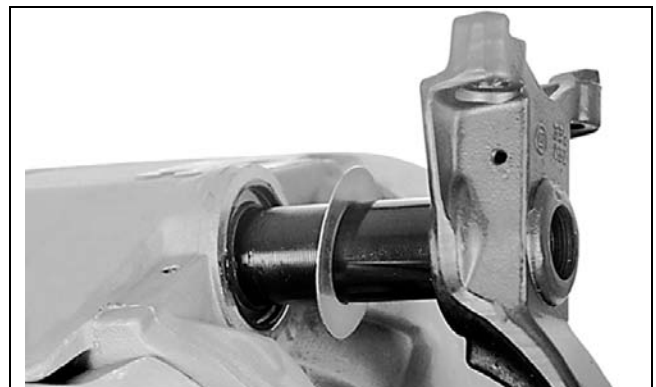

30735

## MIDSECTION

### STERN BRACKET, 40 – 60 HP MANUAL TILT

Install the steering shaft keeper. Apply *Locquic Primer* and *Nut Lock* to the splines of the steering shaft and lower mount bracket.



30736

Install the lower mount bracket and a new locking nut with its unstaked side facing the mount bracket. Align the bracket with the steering arm and tighten the nut to a torque of 130 to 150 ft. lbs. (176 to 204 N·m).



30767

Fill the swivel bracket with *Triple-Guard* grease through the grease fitting on the bracket's port side. Lubricate the tilt tube, swivel bracket, and stern brackets through the two forward grease fittings.

Install the exhaust housing. Refer to **Exhaust Housing Installation** on p. 247.

## STERN BRACKET, 40 – 60 HP Manual Tilt

### Clamp Screw Service

Inspect clamp screw assemblies. Replace swivel plate and retainer if bent or loose. To install a new swivel plate, remove screw and old plate. Apply *Locquic Primer* to the threads of the screw and allow it to dry four to five minutes. Then apply *Ultra Lock* to threads. Install a new swivel plate with screw and tighten securely.

### Stern Bracket Disassembly

Remove bumpers from the upper mount retaining screws.

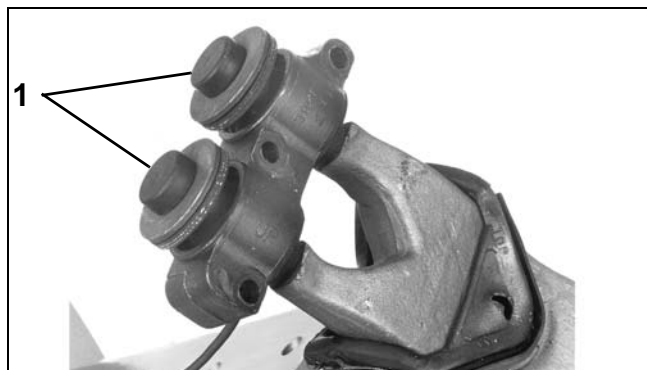

1. Bumpers

COA2949

Remove screws, upper mount, and ground lead from the bracket.

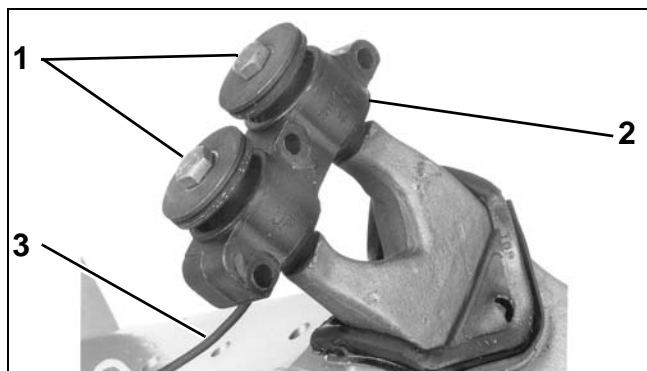

1. Screws  
2. Upper mount  
3. Ground lead

COA2950

Slide the pivot shaft and upper thrust washer out of the swivel bracket.

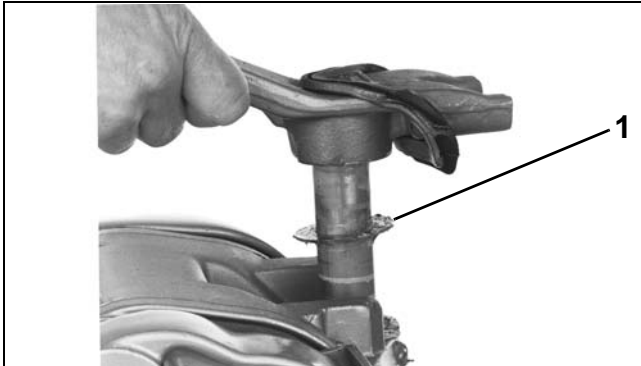

1. Upper thrust washer COA2956

Use an appropriate tool to pry the upper and lower seals from the swivel bracket.

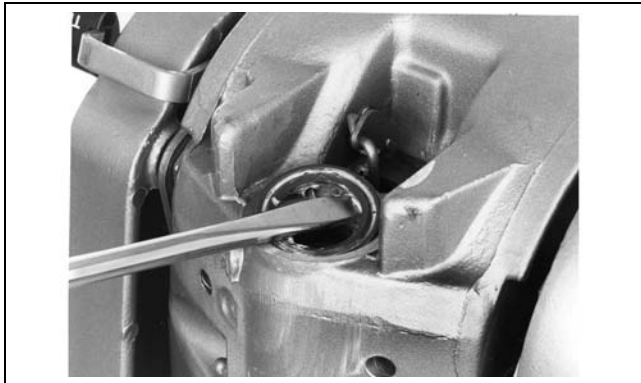

COA2957



COA2958

Loosen the steering friction screw while pushing outward on the steering friction pin. When the pin is flush with the inside surface of the casting, remove the steering friction thrust ring.

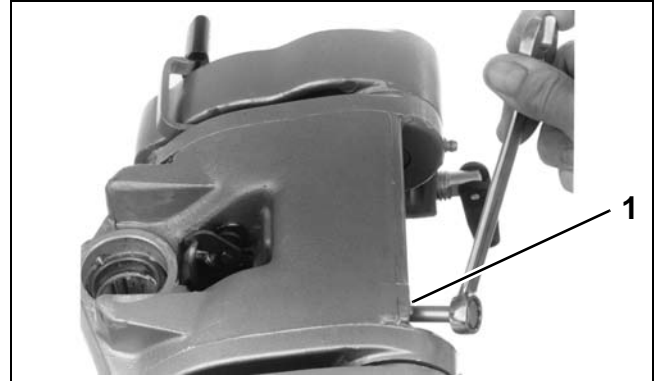

1. Steering friction screw COA2959



1. Steering friction pin  
2. Steering friction thrust ring COA2988

Tighten the steering friction screw until the steering friction pin can be removed. Then, remove the steering friction screw.

Remove the two setscrews from the swivel bracket.

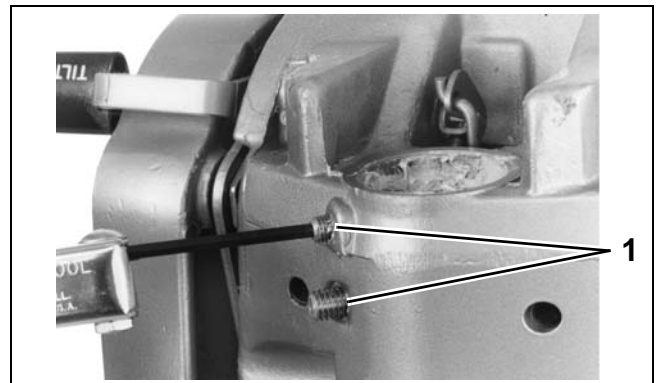

1. Setscrews COA2961



## MIDSECTION

### STERN BRACKET, 40 – 60 HP MANUAL TILT

Drive the steering friction bushing up and out of the swivel bracket.

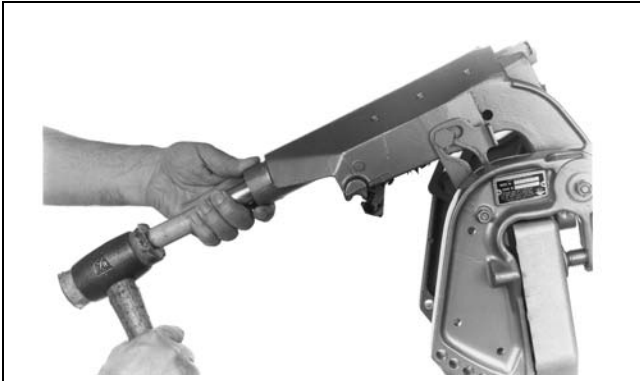

COA2974

Remove the two stern bracket flange screws and separate the stern brackets from the swivel bracket.

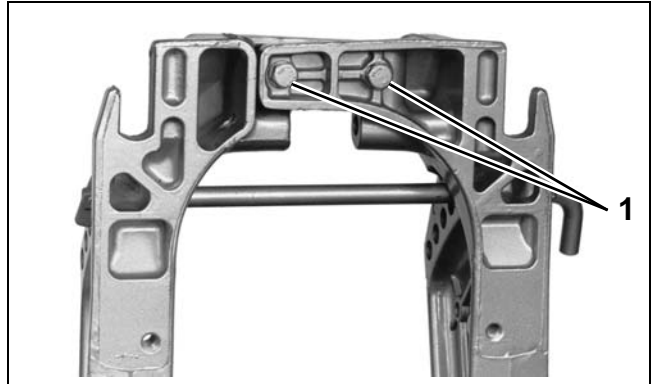

1. Flange screws

COA2992

Remove the thrust rod from the stern brackets. Remove one tilt tube nut, and remove tilt tube from the stern brackets and swivel bracket. Remove the port and starboard stop link screws and nuts from the stern brackets.

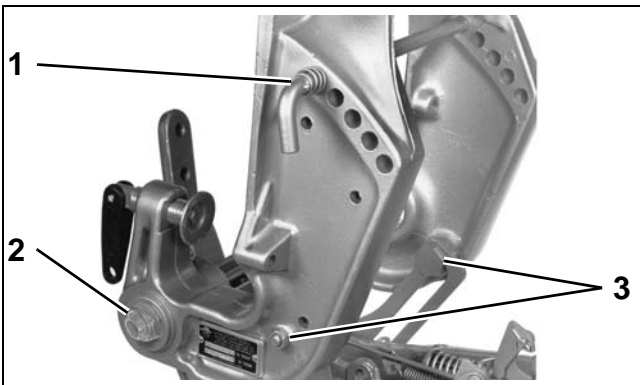

1. Thrust rod
2. Tilt tube nut
3. Stop link screw and nut

COA2991R

Place the tilt/run lever in the RUN position. Loosen the bellcrank setscrew.

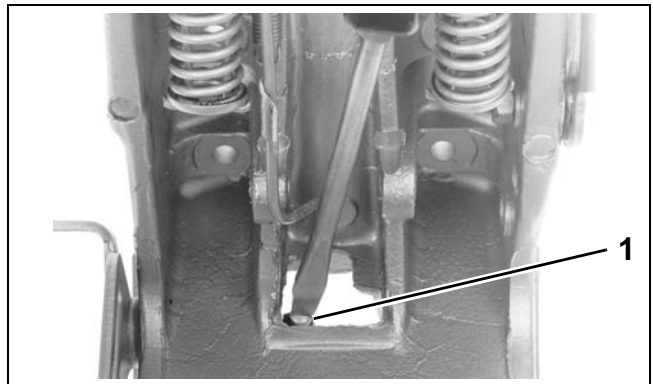

1. Bellcrank setscrew

COA2976

Remove the tilt/run lever, port stop link, and bushing from the swivel bracket.

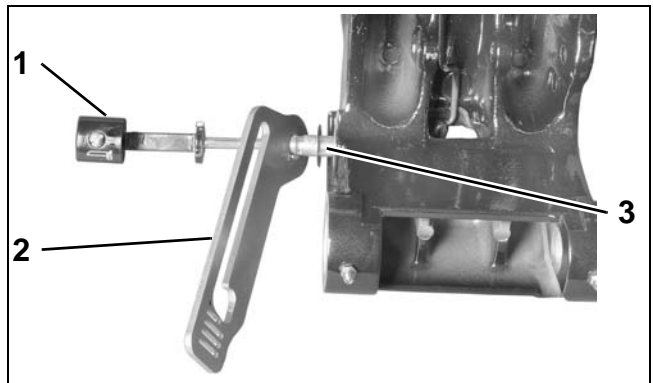

1. Tilt/run lever
2. Port stop link
3. Bushing

002204



Remove the starboard stop link retaining screw and nut from the swivel bracket.

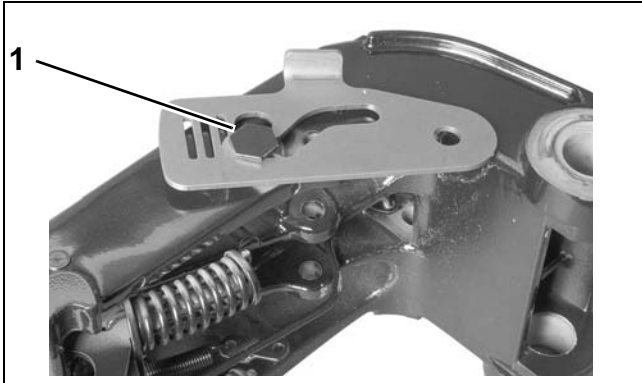

1. Starboard stop link screw 002205

Remove the cotter pins from both reverse lock pins. Remove the reverse lock pins and springs.

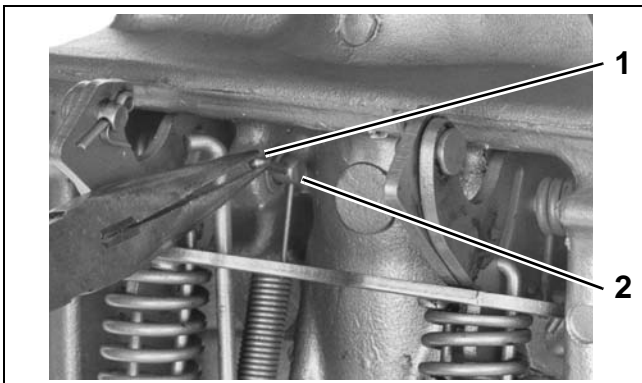

1. Cotter pin COA2979  
2. Reverse lock pin

Remove the reverse lock assembly from the swivel bracket.

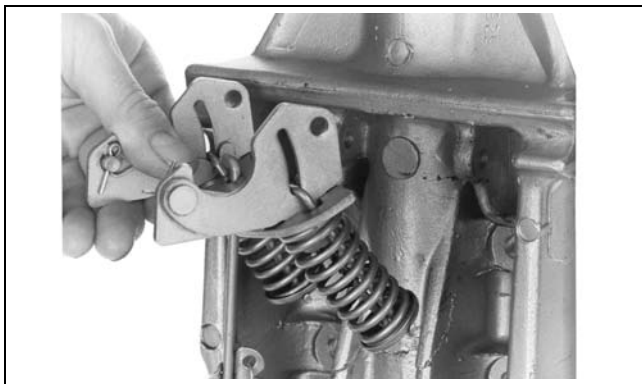

COA2980

## Stern Bracket Assembly

Place the reverse lock springs in the swivel bracket. Insert the reverse lock pins in the swivel bracket and part way through the reverse lock springs. Place the reverse lock assembly between the springs. Push the pins through the springs and the reverse lock assembly.

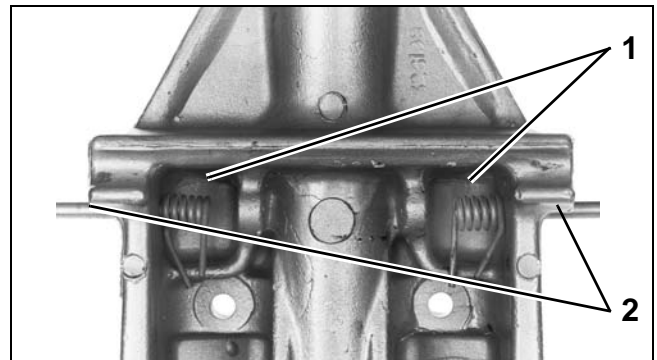

1. Reverse lock springs COA2981  
2. Reverse lock pins

Install the washers on the reverse lock pins. Install the link spring on the port pin. Install the two cotter pins in the reverse lock pins.

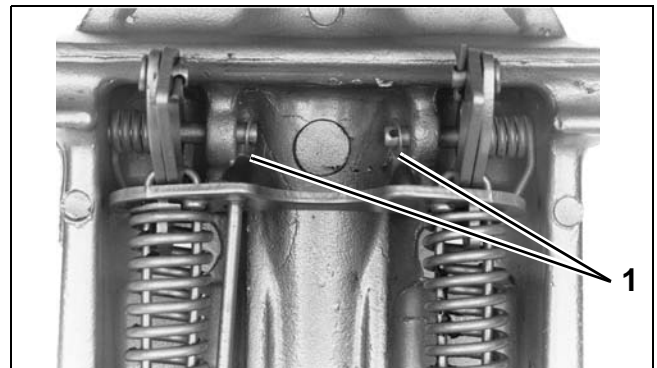

1. Washers COA2982

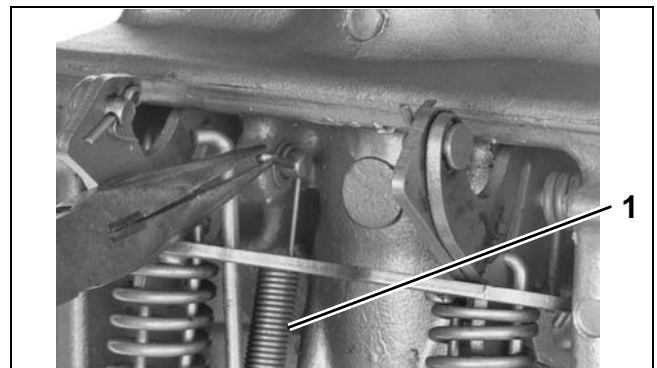

1. Link spring COA2979

## MIDSECTION

### STERN BRACKET, 40 – 60 HP MANUAL TILT

Install the bushing, the port stop link, and the tilt/run lever in the swivel bracket. The tilt/run lever should be in the RUN position.

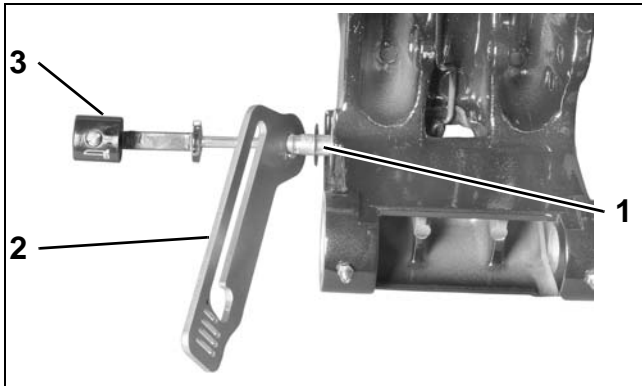

1. Tilt/run lever
2. Port stop link
3. Bushing

002204

Install the wave washer and the bellcrank on the tilt/run shaft. Tighten the setscrew.

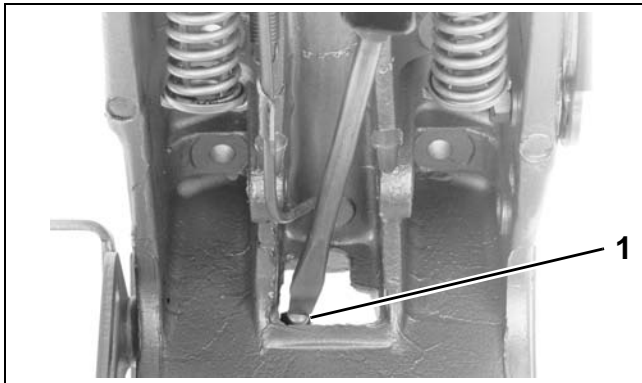

1. Bellcrank setscrew

COA2976

Install the starboard stop link on the swivel bracket. Install and tighten the screw and the nut to a torque of 144 to 168 in. lbs. (16 to 19 N·m).

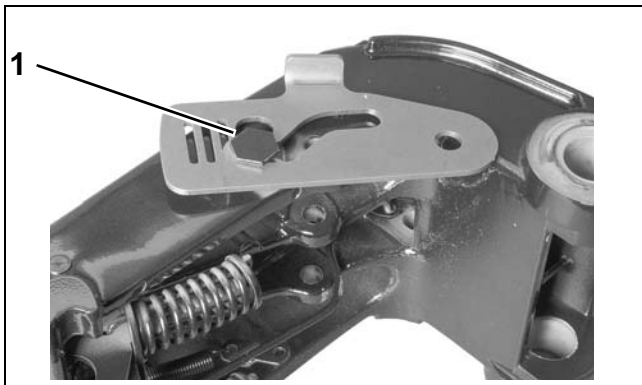

1. Starboard stop link screw

002205

Place the swivel bracket between the stern brackets.

Install the tilt tube through the following parts and install the tilt tube nuts loosely:

- Starboard stern bracket
- Thrust washer
- Bushing
- Swivel bracket
- Bushing
- Thrust washer
- Port stern bracket

Apply *Nut Lock* to threads of the two flange screws. Install the two screws through the starboard stern bracket flange into the port stern bracket flange. Tighten the screws to a torque of 144 to 168 in. lbs. (16 to 19 N·m).

Tighten the tilt tube nuts to a torque of 45 to 50 ft. lbs. (61 to 68 N·m).

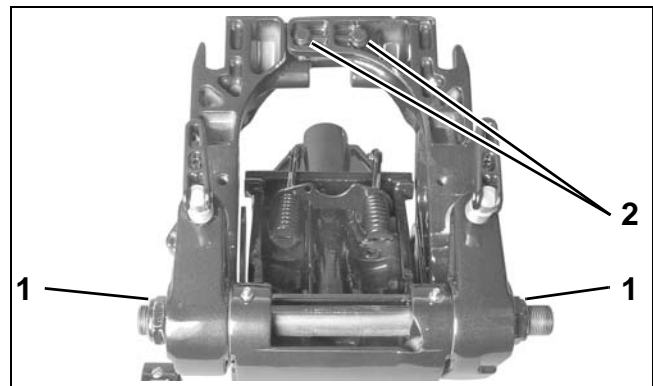

1. Tilt tube nuts
2. Flange screws

002206

Install the thrust rod in the stern brackets.

Install the larger shoulder screw through the port stop link, wave washer, and port stern bracket.

Install and tighten the nut to a torque of 144 to 168 in. lbs. (16 to 19 N·m).

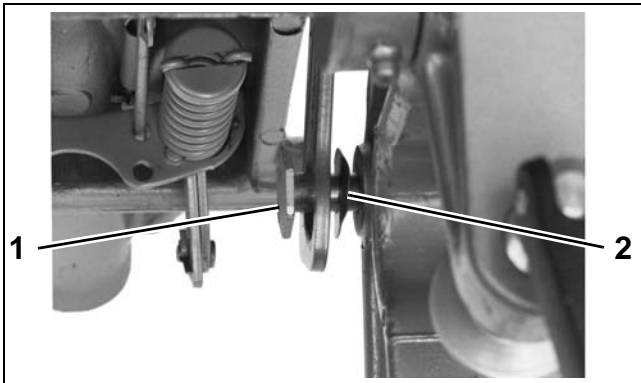

1. Port stop link screw  
2. Wave washer  
COA2984

Install the smaller shoulder screw through the starboard stop link and stern bracket. Install and tighten the nut to a torque of 144 to 168 in. lbs. (16 to 19 N·m).

Apply *Ultra Lock* to threads of large setscrews. Install the screws in the swivel bracket so that one thread remains outside the casting.

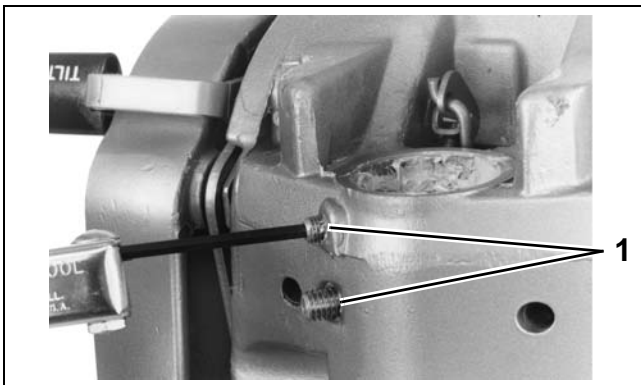

1. Setscrews  
COA2961

Place the steering friction bushing in the swivel bracket with groove in line with the setscrews.



COA2986

Apply *Triple-Guard* grease to the steering friction pin. Install the pin in the swivel bracket flush with inside surface. The pin should point up.



1. Steering friction pin  
COA2988

Install the steering friction thrust ring, bevel side up, in the swivel bracket. Thread the steering friction screw in the swivel bracket. Turn the screw until the steering friction pin makes contact with top of the thrust ring. Do not tighten the screw.

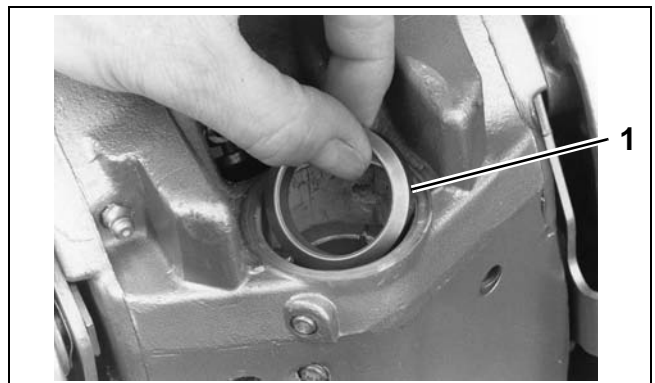

1. Steering friction thrust ring  
COA2987

## MIDSECTION

### STERN BRACKET, 40 – 60 HP MANUAL TILT

Install new upper and lower seals in the swivel bracket with lips of seals facing away from the bracket.

Slide the upper thrust washer on the pivot shaft. Slide the pivot shaft through the swivel bracket.

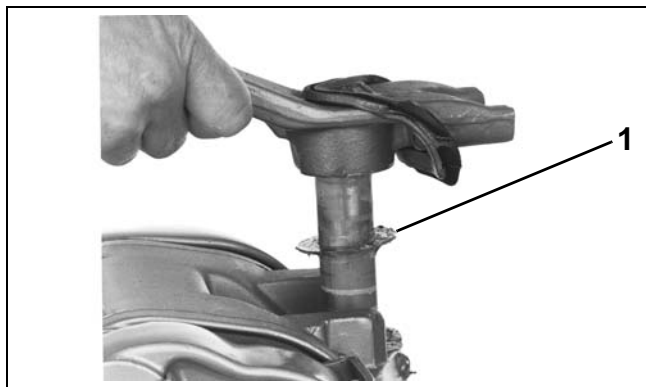

1. Upper thrust washer

COA2956

Lubricate the swivel bracket through the four lubrication fittings with *Triple-Guard* grease.

Apply *Nut Lock* to threads of the upper mount to steering arm screws. Position the upper rubber mount, the upper mount washers, and the retaining washers on the steering arm with the word "UP" on the mount facing up. Be sure to place the ground lead between the mount (starboard side) and the steering arm. Install and tighten the mount retaining screws to a torque of 24 to 26 ft. lbs. (32.5 to 35 N·m).

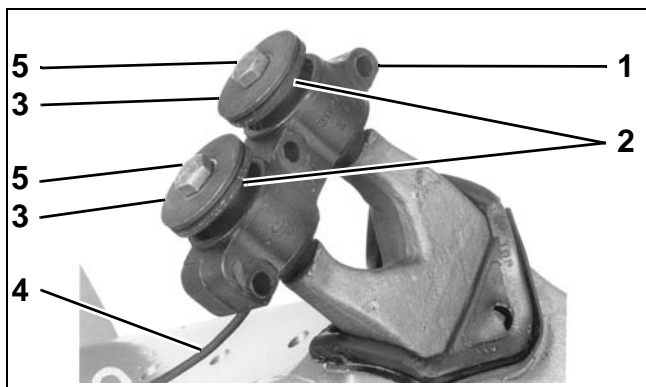

1. Upper mount
2. Upper mount washers
3. Retaining washers
4. Ground lead
5. Retaining screws

COA2950

Place the mount screw bumpers on the upper mount screws.

## Tilt Assist Cylinder

The tilt assist cylinder can be replaced without disassembly of the stern brackets.

### ⚠ WARNING

Support the outboard with a suitable hoist.

Remove port stop link screw. Push port stop link down to clear upper pivot pin access hole.

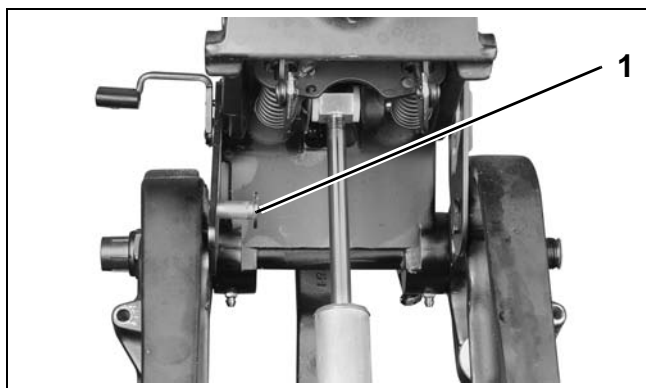

1. Stop link screw

006651

Remove both cotter pins and washers. Use appropriate tool to remove upper pivot pin.

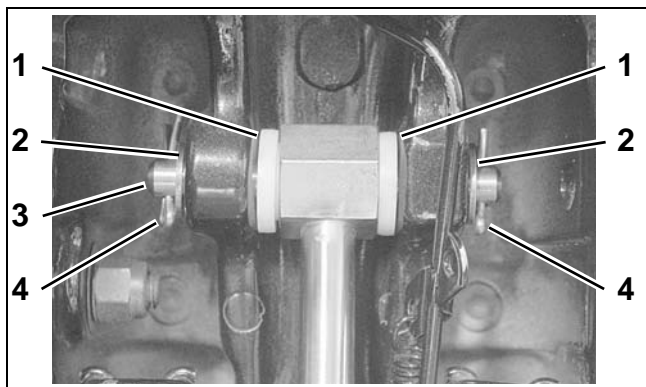

1. Bushings
2. Washers
3. Pivot pin
4. Cotter pins

003939

The starboard stern bracket includes an access hole for the lower tilt pin.

Remove set screw from starboard stern bracket lower pivot pin access hole and use an appropriate tool to remove lower pivot pin.

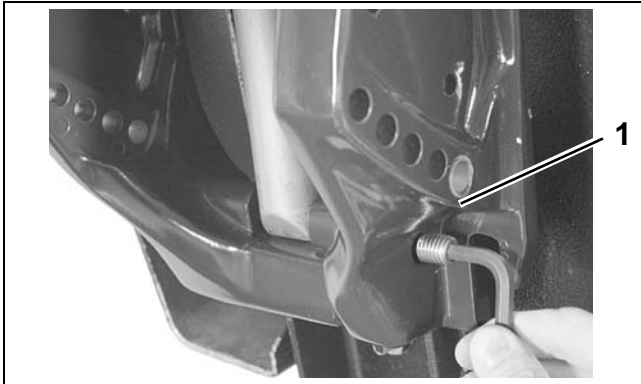

1. Lower pivot pin access hole

004260

If lower pivot cannot be removed because of corrosion or damage, stern brackets may need to be disassembled.



003940

Assembly is the reverse of disassembly. Install **new** cotter pins in upper pivot pin. Install a **new** set screw in starboard stern bracket lower pivot pin access hole and tighten securely.

## STERN BRACKET, 90 HP Manual Tilt

### Stern Bracket Disassembly

Loosen set screw and remove reverse lock release collar.

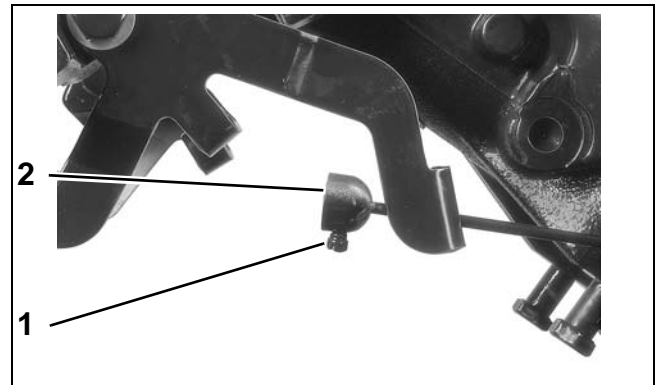

1. Set screw  
2. Reverse lock release collar

006697

Remove reverse lock springs from locking lever and reverse lock spring screws.

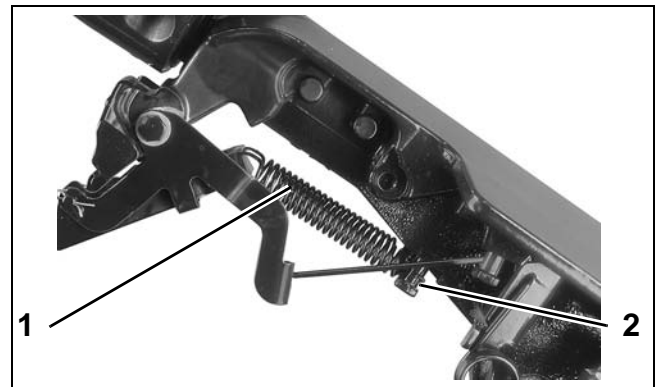

1. Reverse lock springs  
2. Reverse lock spring screws

006700

## MIDSECTION

### STERN BRACKET, 90 HP MANUAL TILT

Remove cotter pins, pins and locking lever.

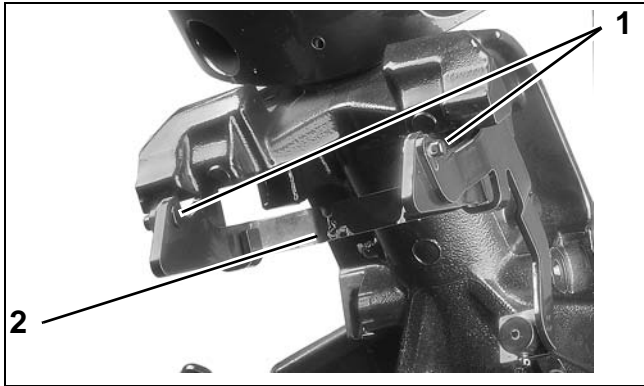

1. Pins
2. Locking lever

006699

Remove port reverse lock link.

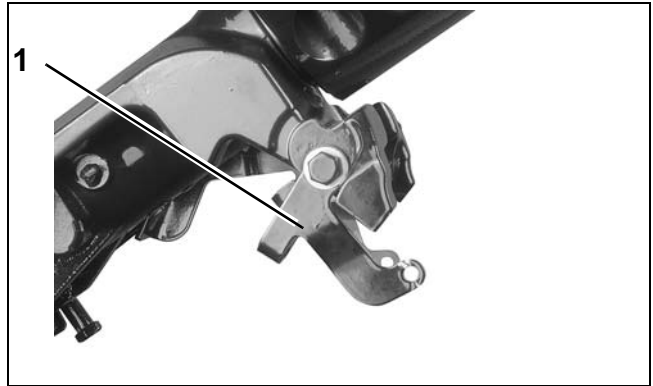

1. Port reverse lock link

006695

Remove starboard reverse lock link.

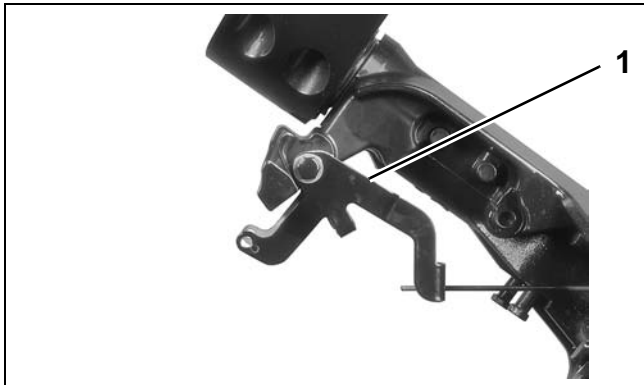

1. Starboard reverse lock link

006696

Loosen bellcrank set screw, remove bellcrank and handle link rod.

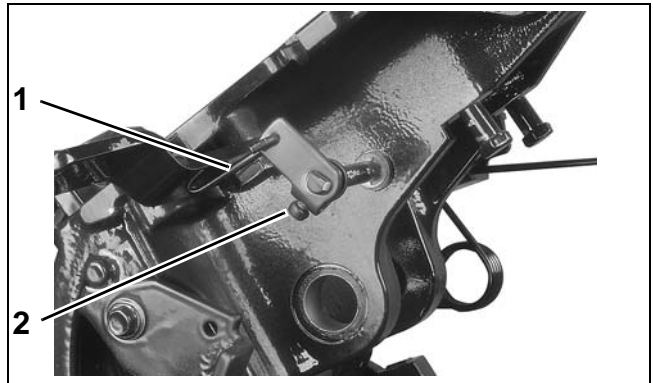

1. Bellcrank set screw
2. Handle link rod

006694

**MIDSECTION**  
**STERN BRACKET, 90 HP MANUAL TILT**

Remove retaining ring and bellcrank shaft spacer from reverse lock pivot shaft.

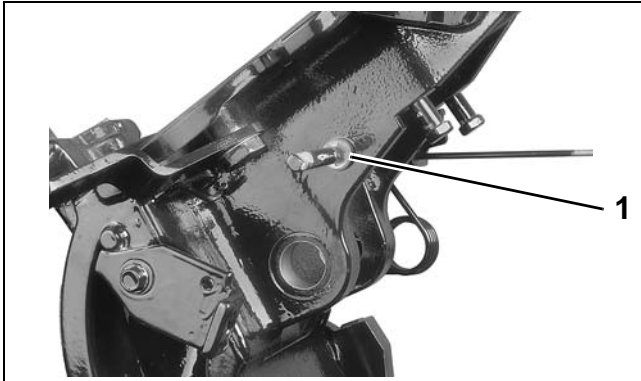

1. Retaining ring

006693

Remove port trail lock lever and trail lock shaft as an assembly.

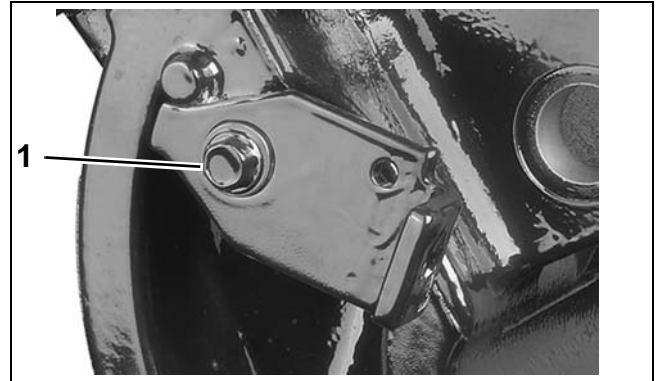

1. Port trail lock lever and shaft

006704

Remove screw from trail lock lever. Remove trail lock lever and reverse lock pivot shaft from swivel bracket.

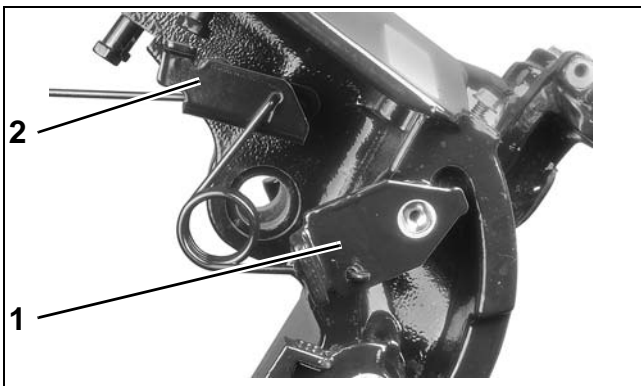

1. Trail lock lever  
2. Reverse lock pivot shaft

006692

Remove port and starboard trail lock shaft bushings from swivel bracket.

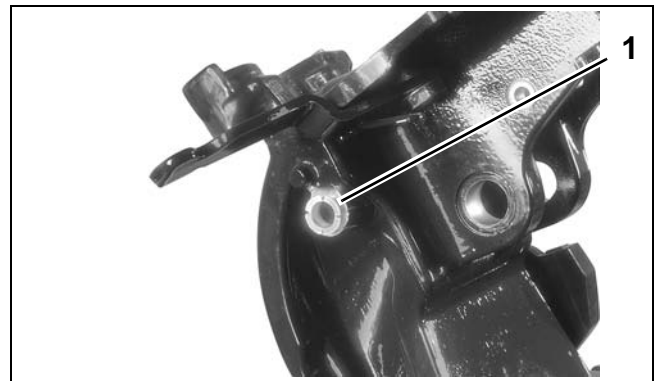

1. Trail lock shaft bushings

006687

## MIDSECTION

### STERN BRACKET, 90 HP MANUAL TILT

## Stern Bracket Assembly

### Reverse Lock and Trail Lock Reference

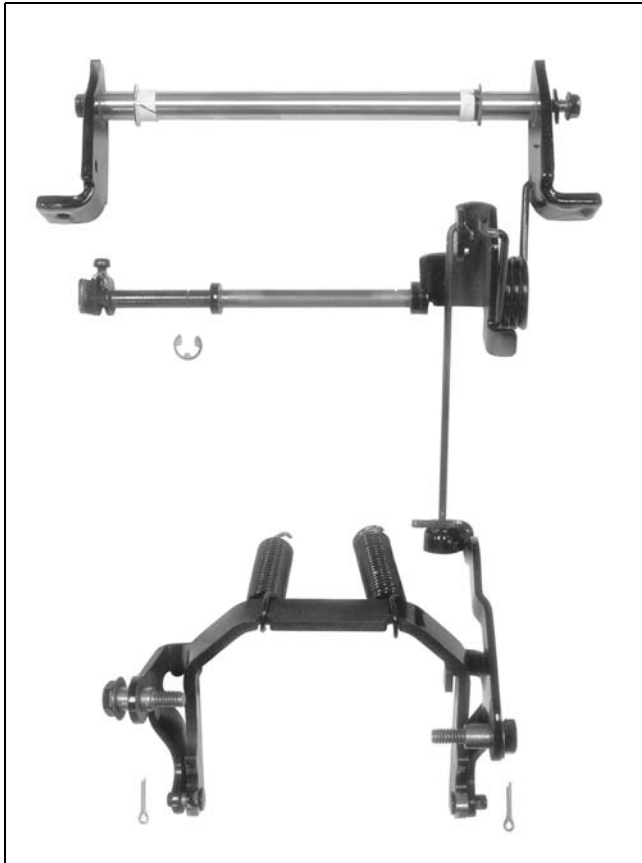

1. Component reference view 2

006686

Place port and starboard trail lock shaft bushings in the swivel bracket.

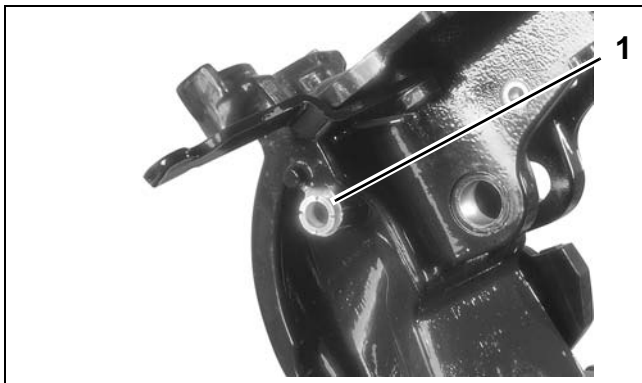

1. Trail lock shaft bushings (port side shown)

006687

Apply blue *Nut Lock* to screw and assemble port trail lock lever on trail lock shaft with screw, washer and nylon washer. Install in swivel bracket from port side. DO NOT tighten screw at this time.

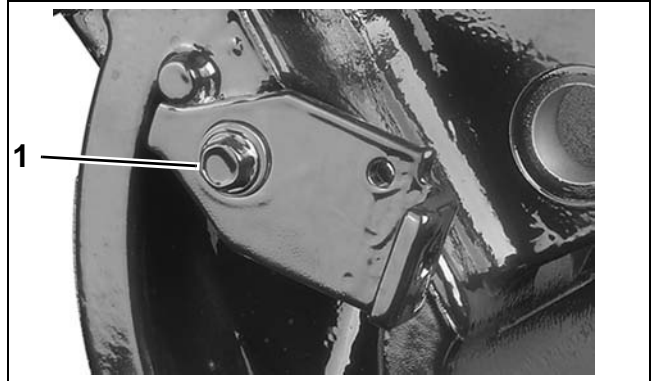

1. Port trail lock lever and shaft

006704

Refer to **Reverse Lock and Trail Lock Reference** on p. 268 for correct orientation of reverse lock and trail lock components.

Assemble reverse lock pivot shaft, reverse lock lever rod and bellcrank shaft spacer as shown.

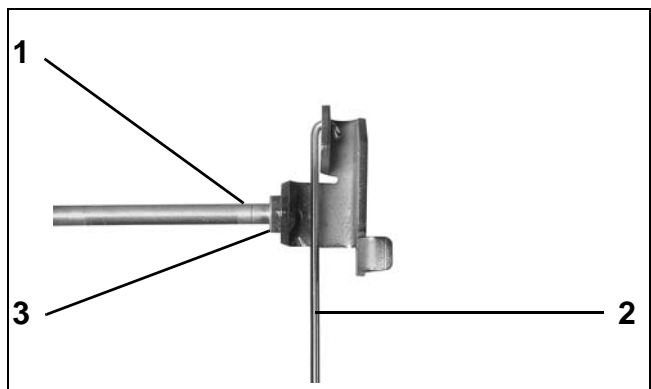

1. Reverse lock pivot shaft  
2. Reverse lock lever rod  
3. Bellcrank shaft spacer

006690



Assemble starboard trail lock lever and trail lock spring to reverse lock pivot shaft.

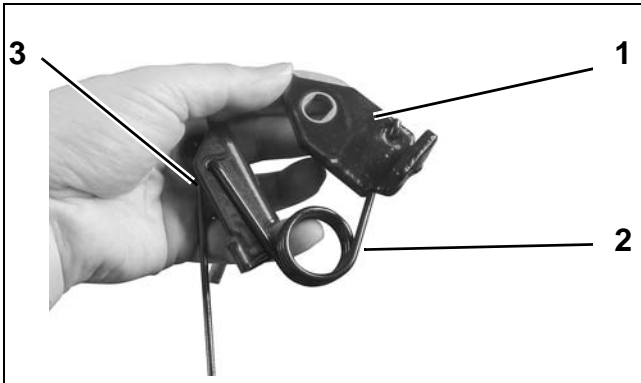

- 1. Trail lock lever 006691
- 2. Trail lock spring
- 3. Reverse lock pivot shaft and rod

Install nylon washer on trail lock shaft and install above components into swivel bracket. Install trail lock washer, apply blue *Nut Lock* to screw and install screw. Tighten both screws to a torque of 60 to 84 in. lbs. (7 to 9.5 N·m).

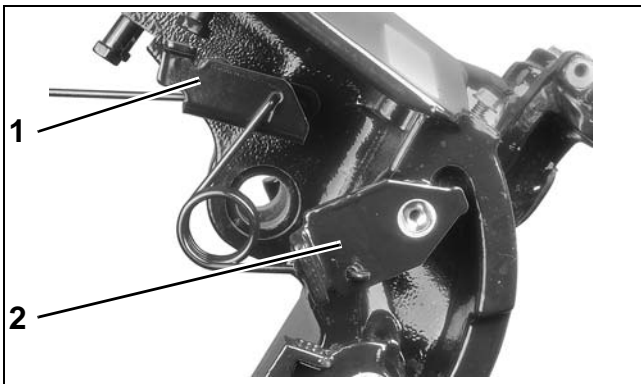

- 1. Reverse lock pivot shaft 006692
- 2. Trail lock lever

Install remaining bellcrank shaft spacer on reverse lock pivot shaft, then install retaining ring.

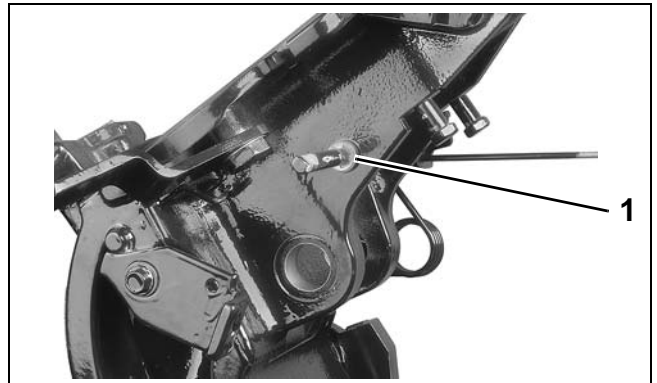

- 1. Retaining ring 006693

Install the handle link rod to reverse lock lever and bellcrank. Install bellcrank on reverse lock pivot shaft. Tighten the setscrew.

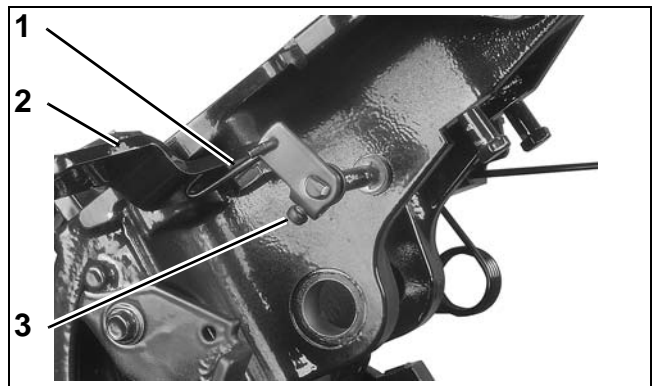

- 1. Handle link rod 006694
- 2. Reverse lock lever
- 3. Bellcrank setscrew

Install the port reverse lock link on the swivel bracket. Install washer screw. Apply blue *Nut Lock* to screw threads and install washer and screw.

## MIDSECTION

### STERN BRACKET, 90 HP MANUAL TILT

Tighten screw to a torque of 60 to 84 in. lbs. (7 to 9.54 N·m).

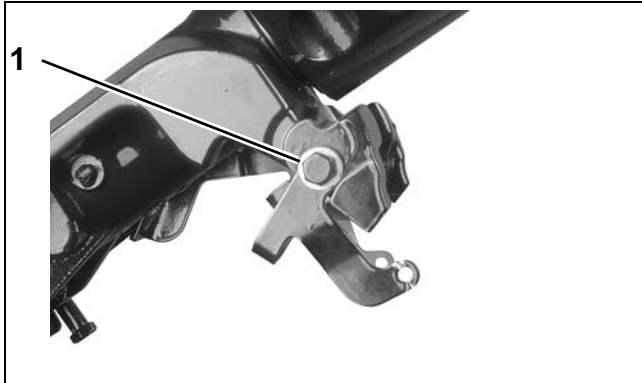

1. Port reverse lock link

006695

Install reverse lock release collar and tighten set screw.

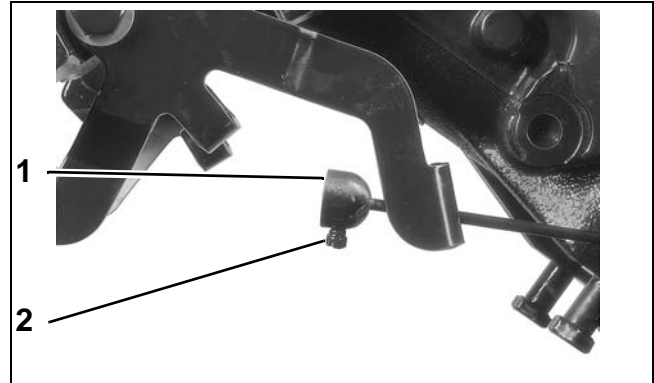

1. Reverse lock release collar  
2. Set screw

006697

Place reverse lock lever rod through hole at top of starboard reverse lock lever. Install the starboard reverse lock link on the swivel bracket. Apply blue Nut Lock to screw threads and install washer and screw. Tighten screw to a torque of 60 to 84 in. lbs. (7 to 9.5 N·m).

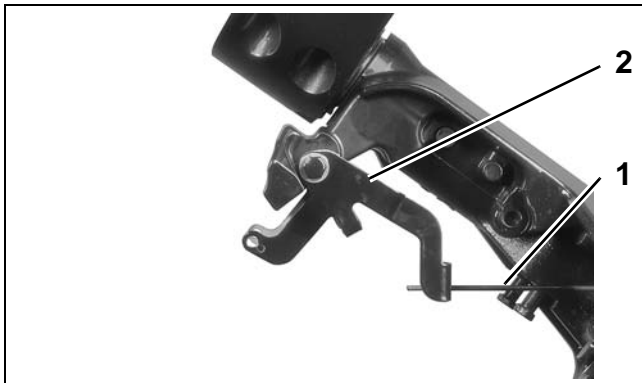

1. Reverse lock lever rod  
2. Starboard reverse lock link

006696

Install locking lever, pins and new cotter pins.

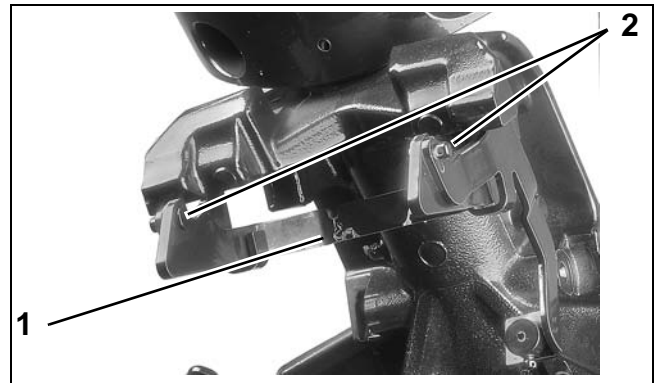

1. Locking lever  
2. Pins

006699

Install reverse lock springs on locking lever and reverse lock spring screws.

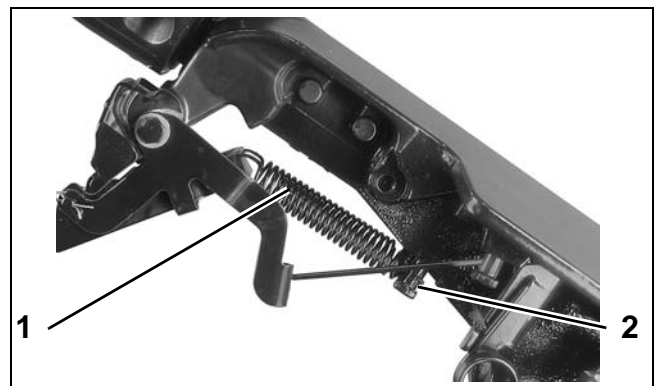

1. Reverse lock springs  
2. Reverse lock spring screws

006700

# TILLER HANDLE SERVICE – Standard

## Removal

**⚠ WARNING**

To avoid accidental starting of engine while servicing, twist and remove all spark plug leads.

Use Ball Socket Remover tool, P/N 342226, to unsnap the throttle cable clip from the throttle lever.

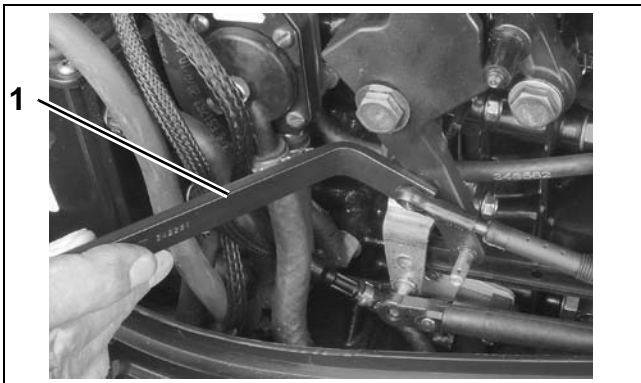

1. Remover tool 005121

Remove the throttle cable anchor screw and washer. Loosen throttle cable retainer screw. And, remove the tie strap holding the tiller handle electrical harness.

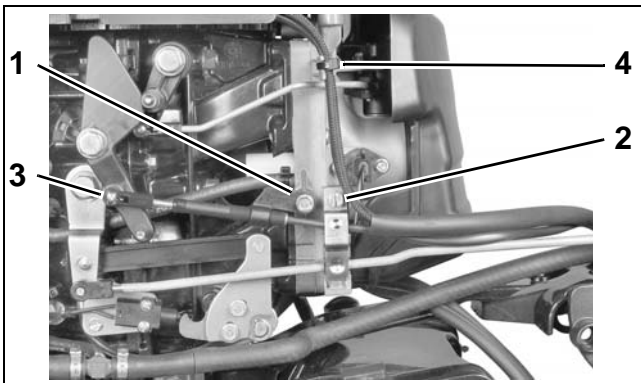

1. Cable anchor screw and washer 002207  
2. Cable retainer screw  
3. Clip  
4. Tie strap

Remove the electrical cover.

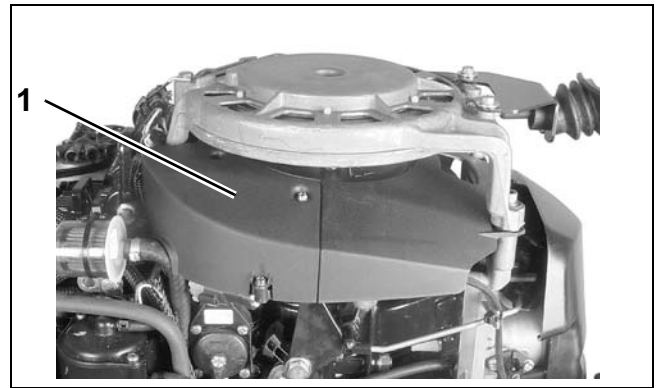

1. Electrical cover 002509

Disconnect the electrical harness coming from the tiller handle.

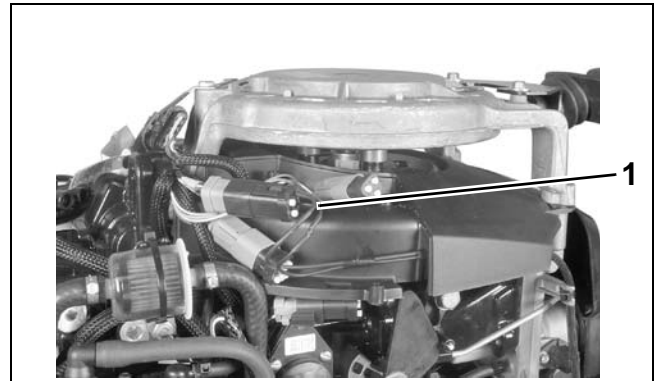

1. Electrical harness connector 002511

Remove throttle cable and wires from grommet in lower engine cover.

Remove the screw attaching steering handle. Remove handle.

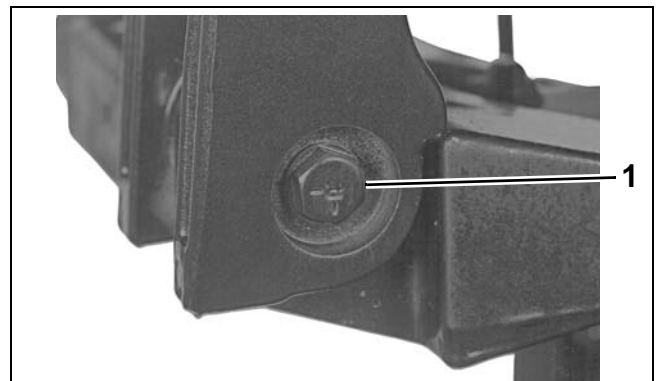

1. Screw 31194

**MIDSECTION**  
**TILLER HANDLE SERVICE – STANDARD**

**Disassembly**

Loosen throttle friction control so there is no restriction on grip.

**IMPORTANT:** Do not back screw out completely. Nut is under spring tension.

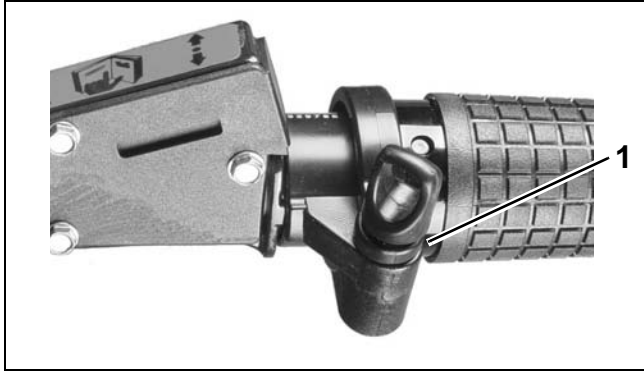

1. Throttle friction control 001259

Use *Twist-Grip Remover*, P/N 390767, to depress the grip detents. Tighten screw and remove the grip by pulling grip.

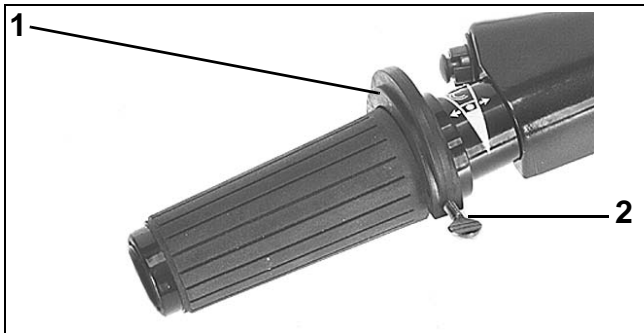

1. Twist-Grip Remover 002189  
 2. Screw

Remove the helix halves, rollers, and guides.

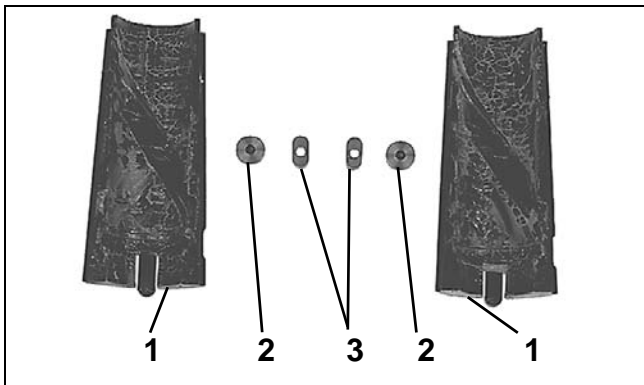

1. Helix halves COA2674  
 2. Rollers  
 3. Guides

Pull the throttle pin out of the cable.

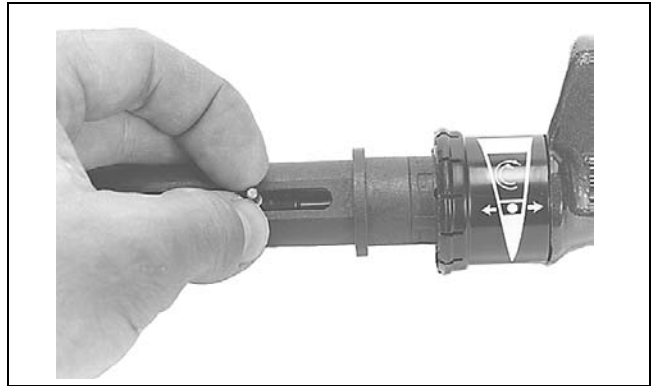

24294

Remove stop switch cover screws and cover/stop switch assembly.

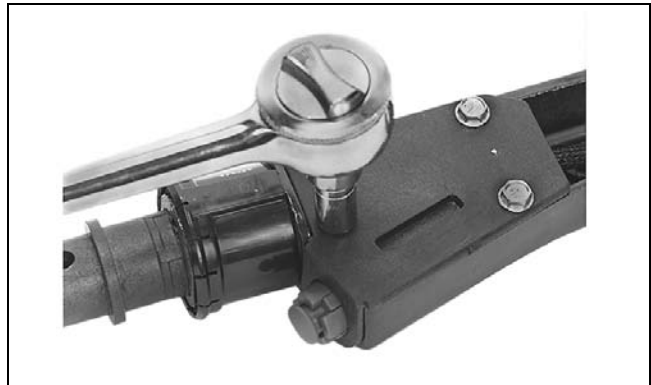

24288

Remove the throttle control plate.

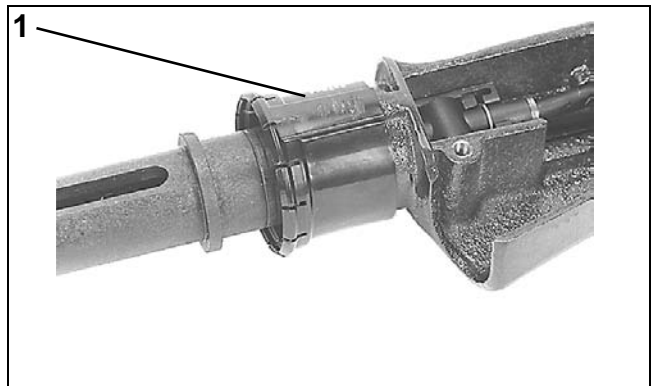

1. Throttle control plate 24287

Remove the throttle cable retaining clip. Pry the cable trunnion out of the steering handle and remove cable.

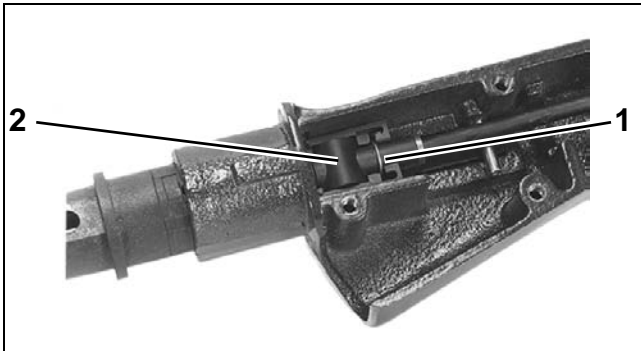

1. Retaining clip  
 2. Cable trunnion  
 24286

**IMPORTANT:** DO NOT remove the inner handle except to replace it.

Use a punch and mallet to drive out the steel pin holding the inner handle into the steering handle.

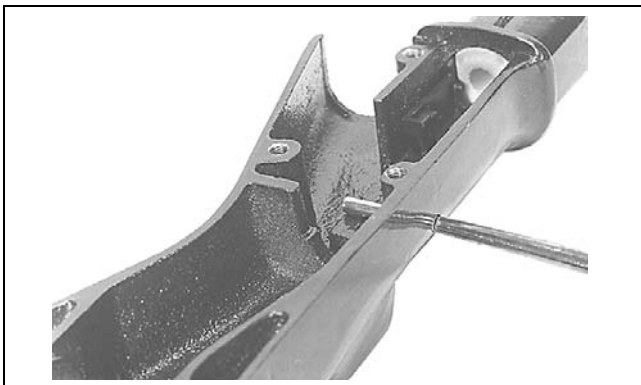

24285

Remove the plastic inner handle from the metal outer handle by driving the outer handle off with a mallet and a punch. Inner handle is bonded to the

outer handle. After removing, chip away remnants of inner handle.

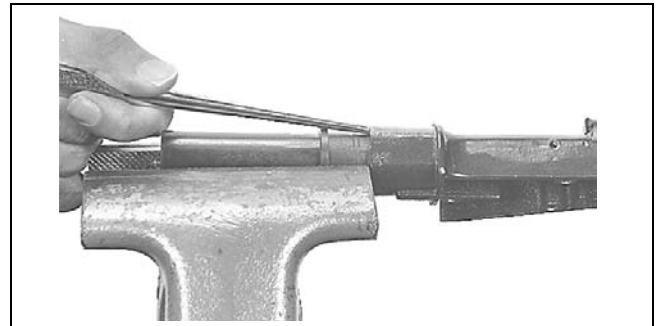

24284

Remove throttle cable seal from the inner handle.

### Inspection

Inspect the throttle cable for kinks and wear. Replace if necessary.

Inspect the steering handle components for wear, cracks, or damage. Replace parts if necessary.

### Assembly

Install the throttle cable seal in inner handle.

If removed, apply *Loctite Depend 300* adhesive to inner handle at areas shown.

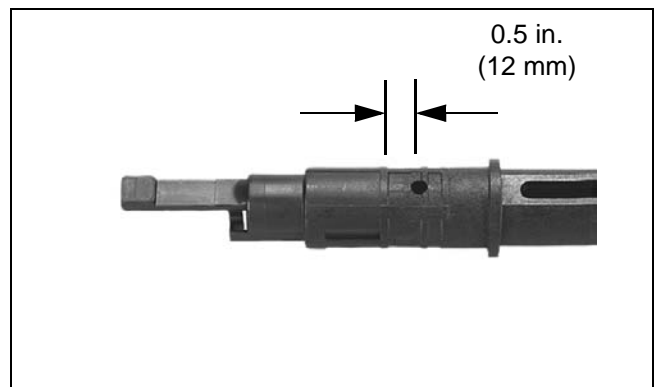

20849

## MIDSECTION

### TILLER HANDLE SERVICE – STANDARD

Install the metal outer handle over the plastic inner handle and drive the outer handle into place.



31202

Secure tab of the inner handle into recess of the outer handle with the steel pin.

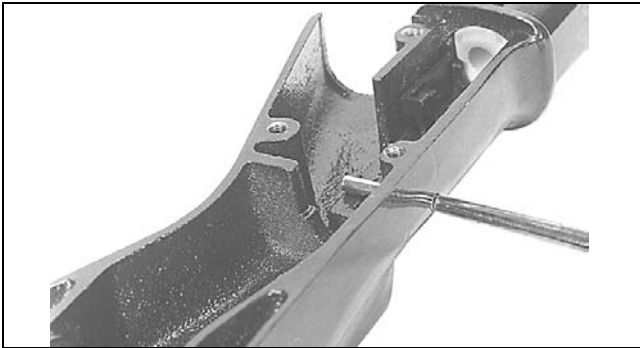

24285

Install the handle end of the throttle cable. Snap the throttle cable trunnion into the recess in the handle. Install the retainer clip.

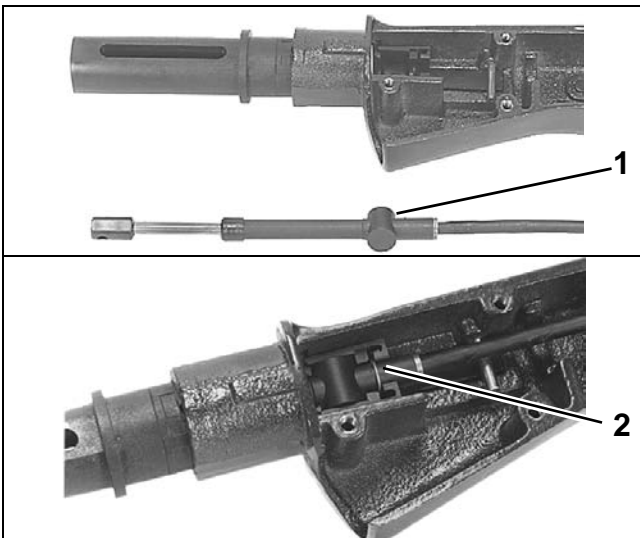

1. Throttle cable trunnion
2. Retainer clip

24282  
24286

Install the throttle control plate on outer handle.

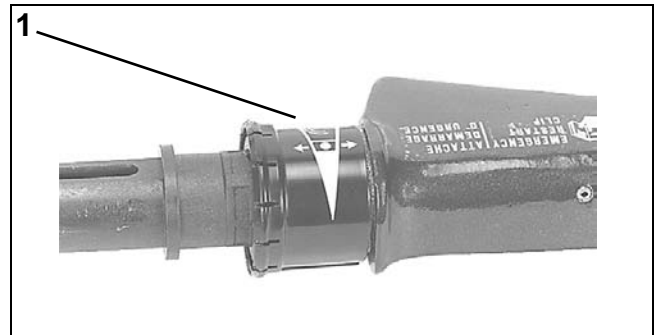

1. Throttle control plate

24295

Push the throttle cable pin through the end of the throttle cable.

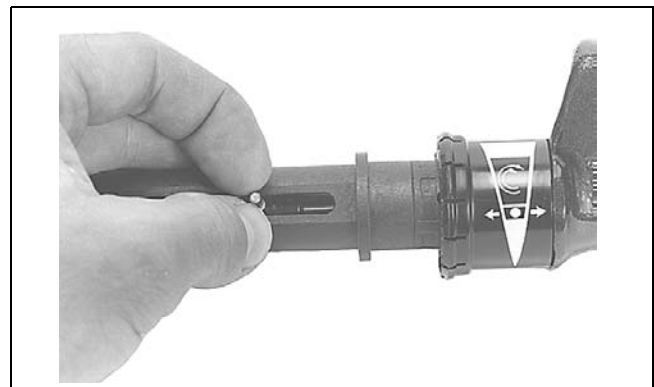

24294

Lubricate end of the pin, guides, rollers, helix grooves, and inner handle guide slot with *Moly Lube*. Place the guides over the roller pin and into the slots of the inner handle. Place the rollers on the ends of the roller pin. Assemble the helix halves on the handle and slide the grip over the helix.

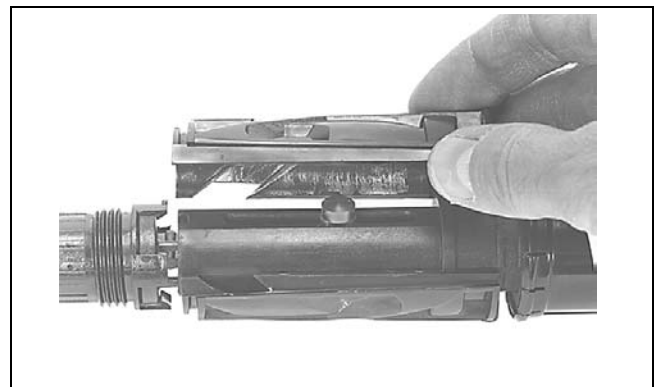

24293

Be sure the twist-grip's speed indicator line is positioned with the speed range symbol on the handle. Snap the grip into place.

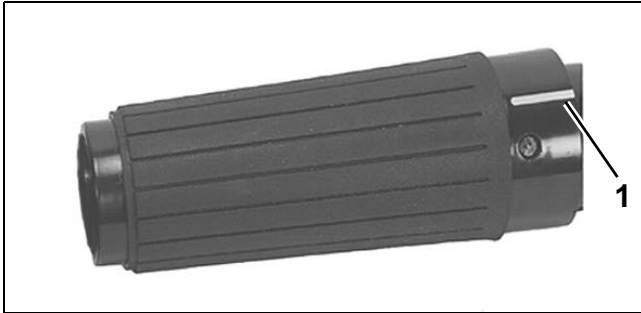

1. Indicator line

002190

Slide the protective sleeve over the stop switch leads and throttle cable and install stop switch cover.

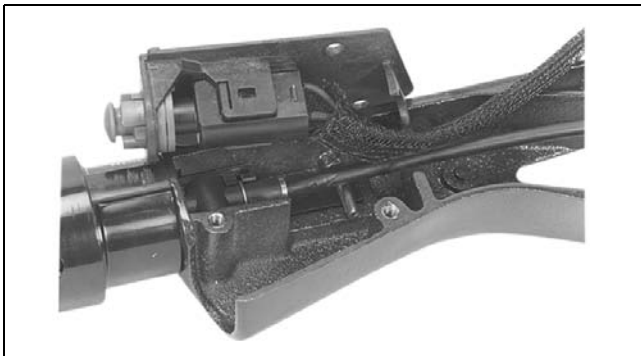

24291



24288

## Installation

Apply *Triple-Guard* grease to the two steering handle bushings. Place the bushings into the steering bracket. Attach the steering handle to the bracket. Tighten screw to a torque of 36 to 40 ft. lbs. (49 to 54 N·m).

### ⚠ CAUTION

The steering handle nut must have a nylon patch for locking. Replace the nut if it has lost its locking feature. Tighten the nut so the steering handle can be pivoted and maintained in any position.

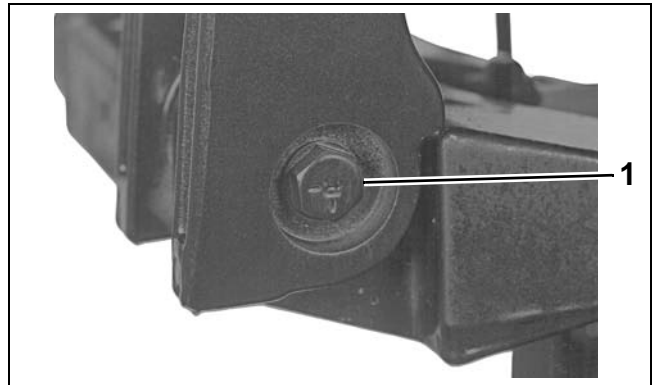

1. Screw

31194

Route throttle cable and electrical harness through grommet in lower motor cover. Connect harness to engine wiring harness.

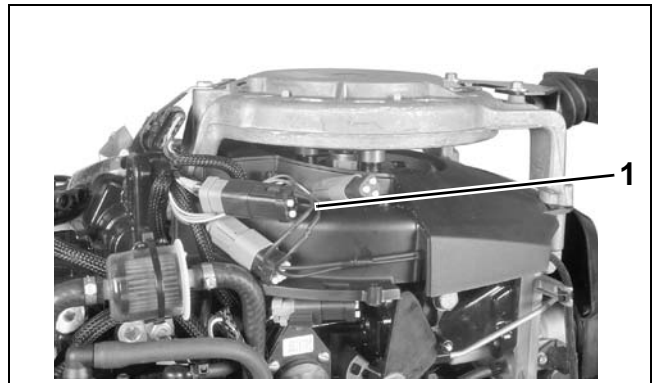

1. Electrical harness connector

002511

## MIDSECTION TILLER HANDLE SERVICE – STANDARD

Install electrical cover.

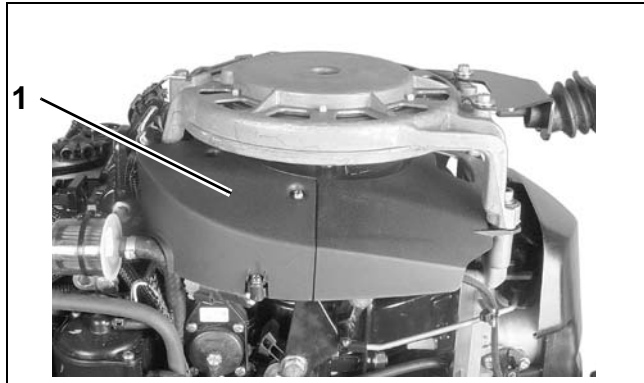

1. Electrical cover

002509

Secure electrical harness with tie strap.

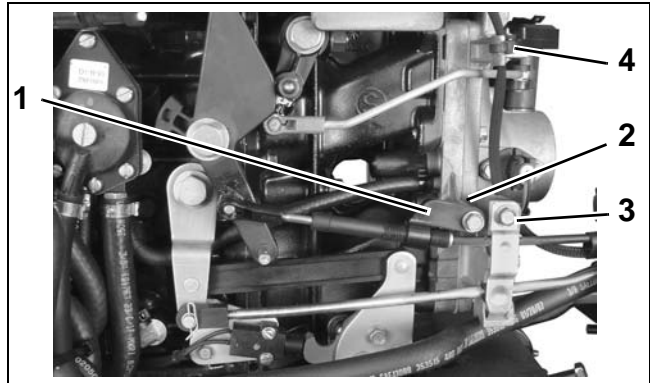

1. Cable anchor  
2. Boss  
3. Cable retainer  
4. Tie strap

006526

## Throttle Cable Adjustment

Place throttle cable in position. Use Ball Socket Installer tool, P/N 342225, to snap throttle cable connector onto throttle lever.



1. Installer tool

005106

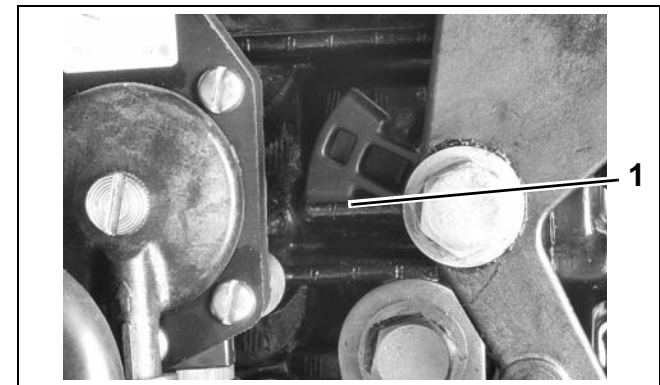

1. Throttle lever stop

005114

Place throttle cable in upper anchor pocket. Install cable retainer on anchor block.

Hold twist grip in full SLOW position. Pull firmly on cable to remove backlash.

Adjust cable anchor so throttle cam is against idle stop when anchor screw aligns with throttle body boss. Then, rotate anchor four turns toward the end of the cable.

Install washer, cable anchor, and cable anchor screw on throttle body boss. Tighten screw securely.



1. Turn anchor four turns toward cable end.

006564

**IMPORTANT:** Rotate twist grip. Make sure throttle cam goes to full throttle without bending cable, and still returns to IDLE stop.



# TILLER HANDLE SERVICE – Long Handle

## Removal

**⚠ WARNING**

To avoid accidental starting of engine while servicing, twist and remove all spark plug leads.

Use Ball Socket Remover tool, P/N 342226, to unsnap the throttle cable clip from the throttle lever.

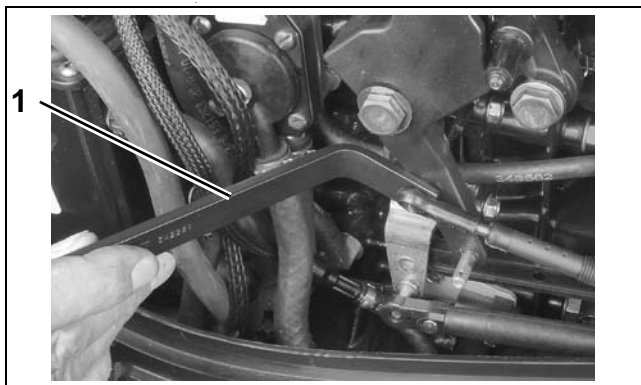

1. Remover tool 005121

Remove the throttle cable anchor screw and washer. Loosen throttle cable retainer screw. And, remove the tie strap holding the tiller handle electrical harness.

Remove retainer clip from shift cable.

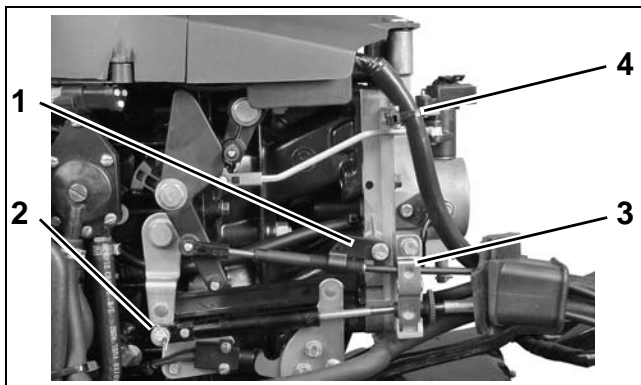

1. Throttle cable anchor  
2. Shift cable retainer clip  
3. Cable retainer  
4. Tie strap 006745

Remove the electrical cover.

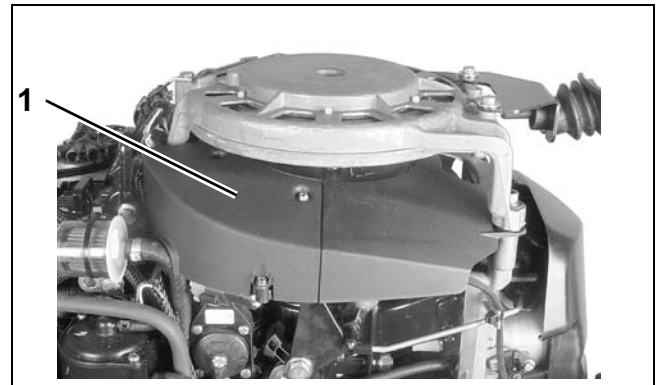

1. Electrical cover 002509

Disconnect the electrical harness coming from the tiller handle.

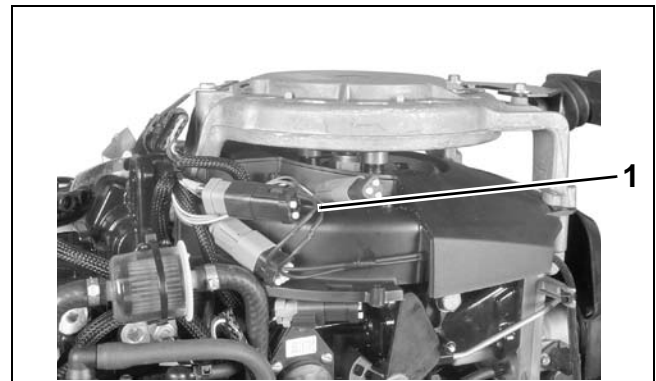

Rope Start models  
1. Electrical harness connector 002511

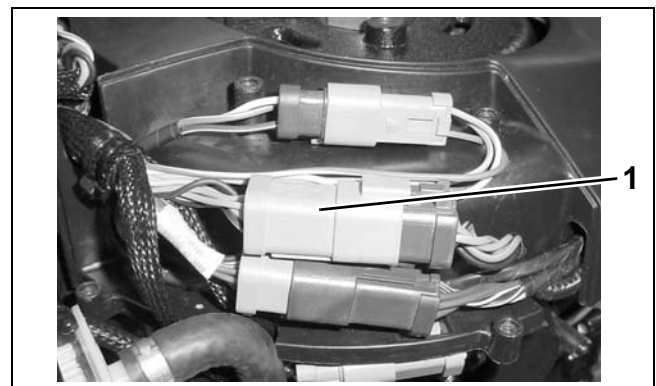

Tiller Electric models  
1. Electrical harness connectors 001999

Remove shift and throttle cables and wire harness from grommet in lower engine cover.

## MIDSECTION

### TILLER HANDLE SERVICE – LONG HANDLE

Remove locknuts from screws on top of steering arm.

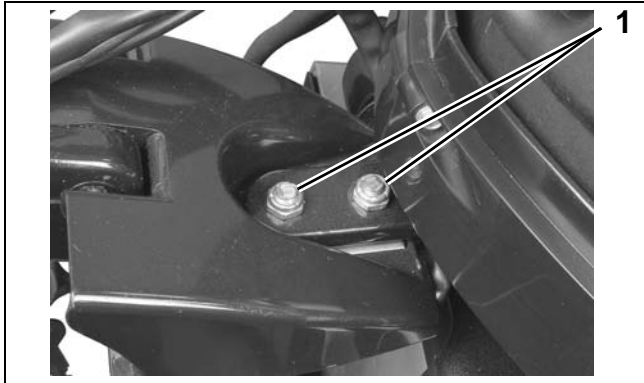

1. Screw

006362

Remove the screws attaching tiller bracket to steering arm. Remove tiller bracket and handle.

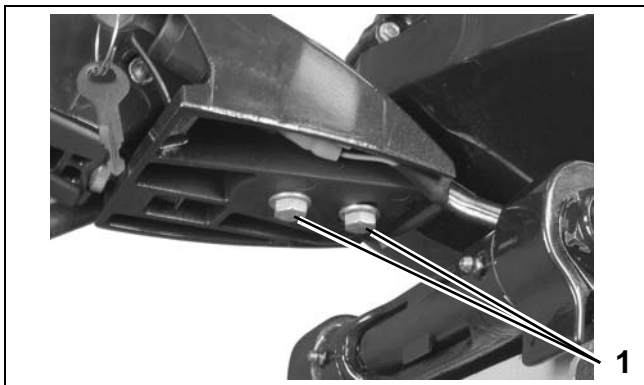

1. Screw

006361

## Disassembly

Loosen throttle friction control so there is no restriction on grip.

**IMPORTANT:** Do not back screw out completely. Nut is under spring tension.

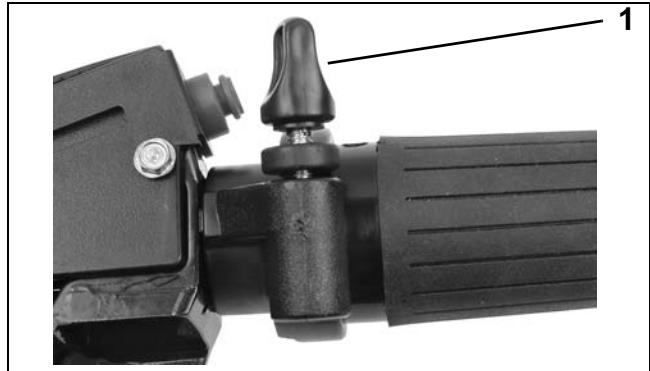

1. Throttle friction control

006711

Remove seven screws and bottom cover of tiller handle.

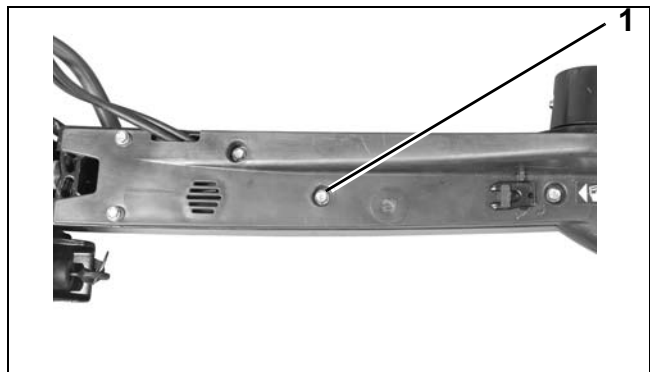

1. Cover screw

006566

Remove stop switch cover screws, unplug stop switch electrical connector and remove stop switch assembly.

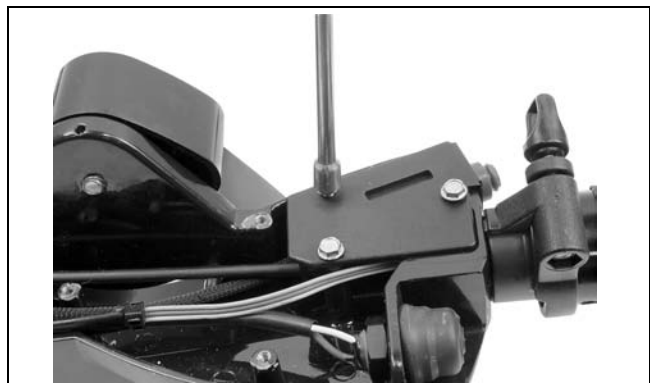

006713

Disconnect trim switch connector. Remove connector from trim switch wires. Refer to **CONNECTOR SERVICING** on p. 116.

Use *Twist-Grip Remover*, P/N 390767, to depress the grip detents. Tighten screw and remove the grip by pulling grip.

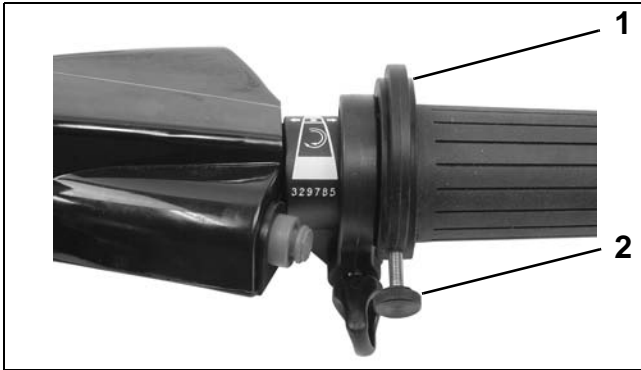

1. *Twist-Grip Remover* 006710  
2. *Screw*

Remove the helix halves, rollers, and guides.

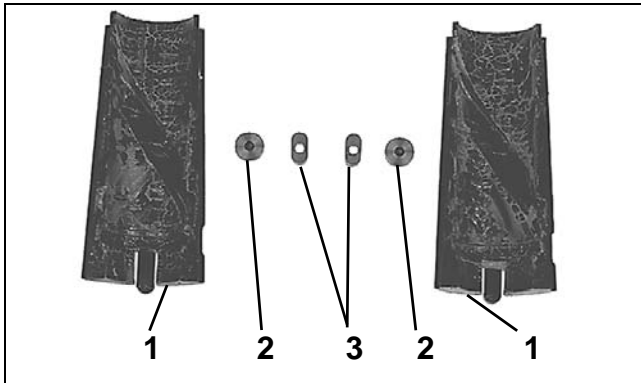

1. *Helix halves* COA2674  
2. *Rollers*  
3. *Guides*

Pull the throttle pin out of the cable.

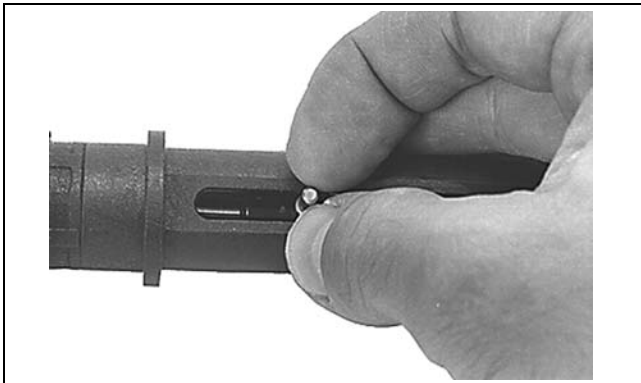

006712

Remove the throttle friction control.

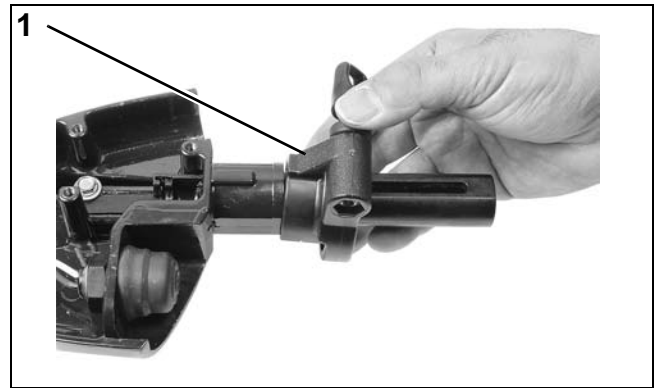

1. *Throttle friction control* 006671

Remove the throttle cable retaining clip. Pry the cable trunnion out of the steering handle and remove cable.

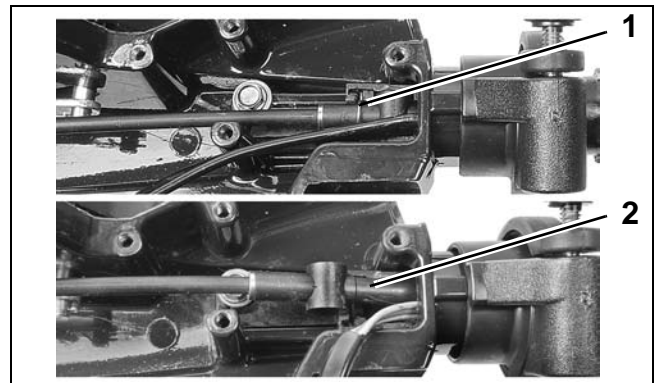

1. *Retainer* 006674  
2. *Throttle cable trunnion*

The trim switch wiring can now be removed from the inner handle.

Remove the screw and washer retaining the inner handle tab.

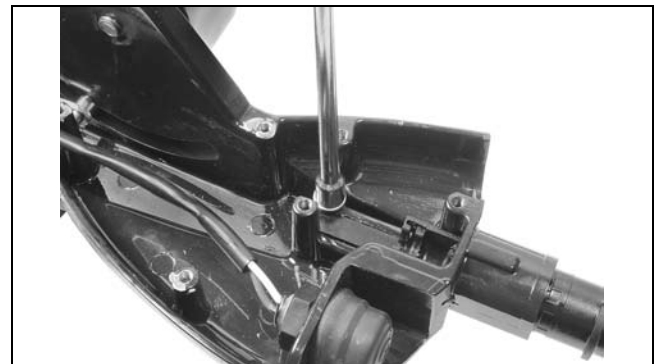

006681

## MIDSECTION

### TILLER HANDLE SERVICE – LONG HANDLE

Use an appropriate tool to carefully pry up on the inner handle retaining tab.

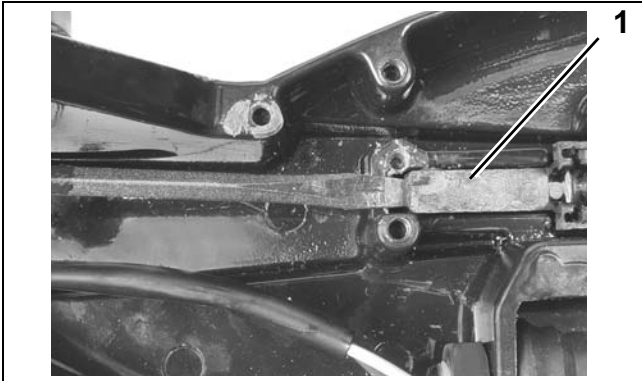

1. Inner handle retaining tab

006679

Remove cotter pin from shift handle pin. Remove shift cable.



1. Cotter pin

006708

Use a wooden dowel and a soft mallet to remove the inner handle.

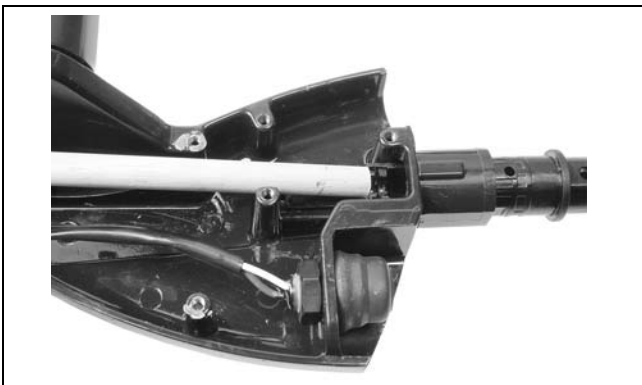

006678

Remove shift handle screw and washer. Remove shift handle, bushing and washer.

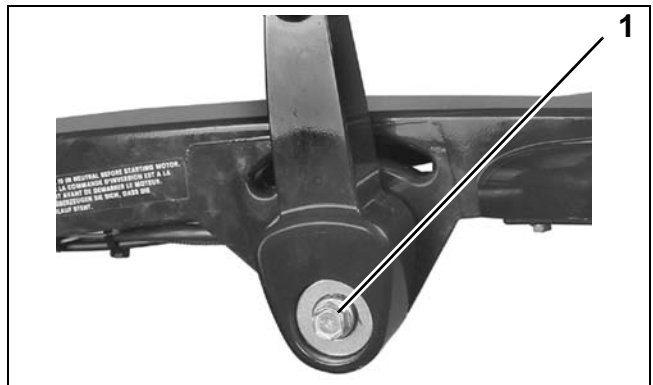

1. Shift handle screw

006714

Remove shift cable retainer from shift cable trunion.

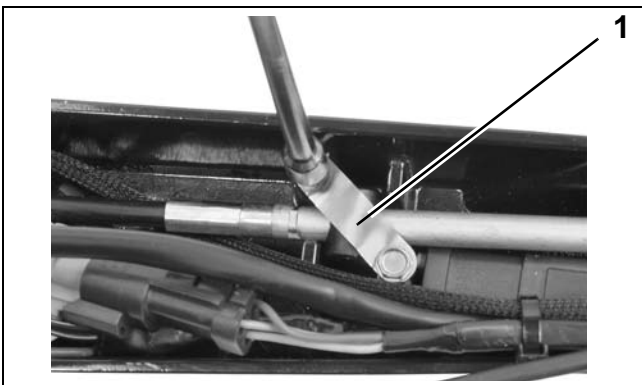

1. Shift cable retainer

006721

Remove shift handle detent ball, spring and guide.

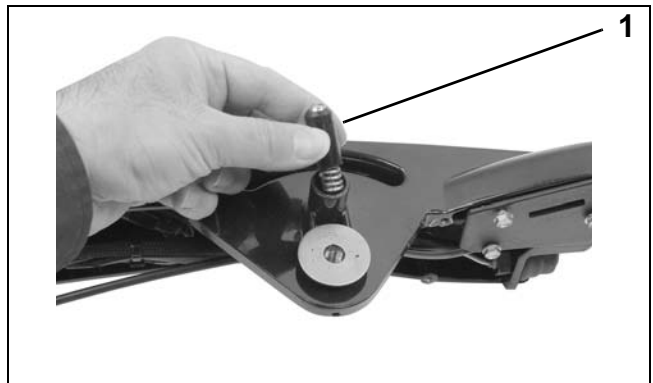

1. Detent ball, spring and guide

006715

Remove the shift pin if necessary.

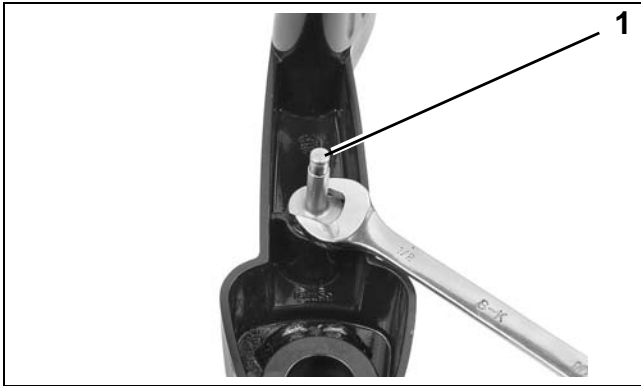

1. Shift pin 006716

**Inspection**

Inspect the throttle cable for kinks and wear. Replace if necessary.

Inspect the shift cable for kinks and wear. Replace if necessary.

Inspect the steering handle components for wear, cracks, or damage. Replace parts if necessary.

**Assembly**

Apply *Nut Lock* to threads of shift pin and install shift pin into shift handle. Tighten to a torque of 18 to 22 ft. lbs. (24.5 to 29 N·m).



1. Detent ball, spring and guide 006716

Coat detent ball, spring and guide with *Triple-Guard* grease and install into shift handle. Place one washer on shift handle mounting boss.

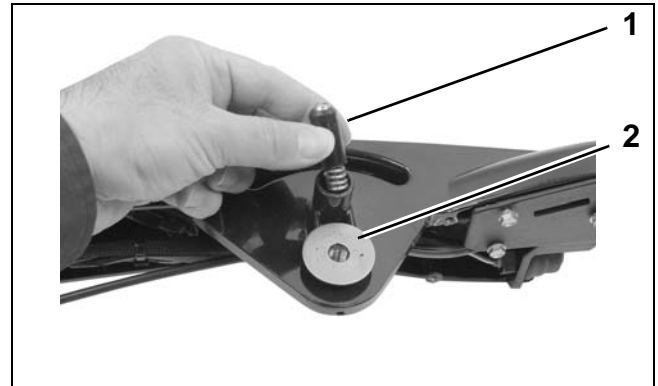

1. Detent ball, spring and guide 006715  
2. Washer

Coat bushing and washer with *Triple-Guard* grease. Apply *Nut Lock* to threads of screw.

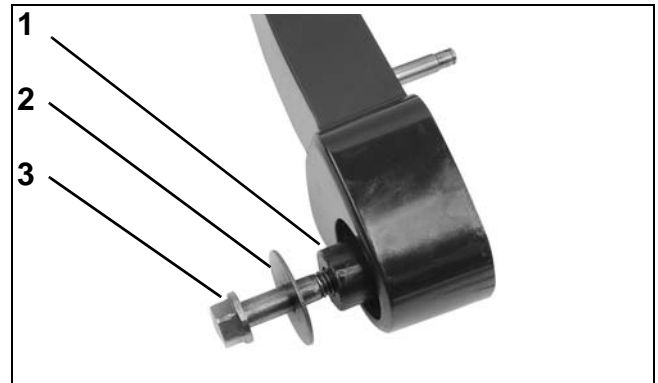

1. Bushing 006717  
2. Washer  
3. Screw

Install shift handle on tiller handle and tighten screw to a torque of 18 to 20 ft. lbs. (24.5 to 27 N·m).

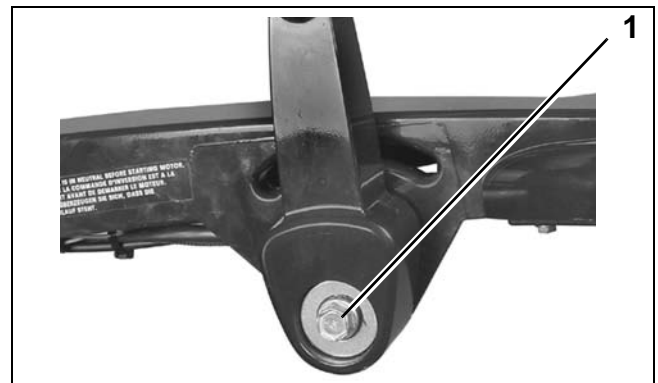

1. Shift handle screw 006714

## MIDSECTION

### TILLER HANDLE SERVICE – LONG HANDLE

Install shift cable on shift pin with a new cotter pin.

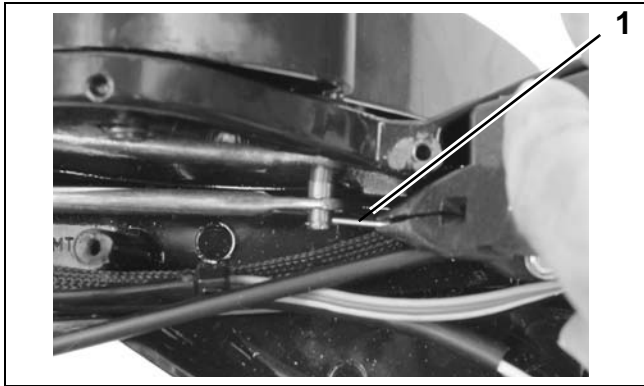

1. Cotter pin

006720

Install shift cable retainer on shift cable trunnion.

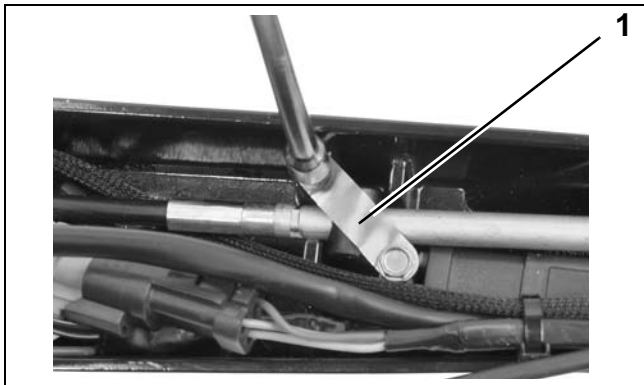

1. Shift cable retainer

006721

Use a soft-faced mallet to install the inner handle.



006680

Secure tab of the inner handle into the outer handle. Tab must be flush with the back of the flange and top of tab must be flush with top of flange.

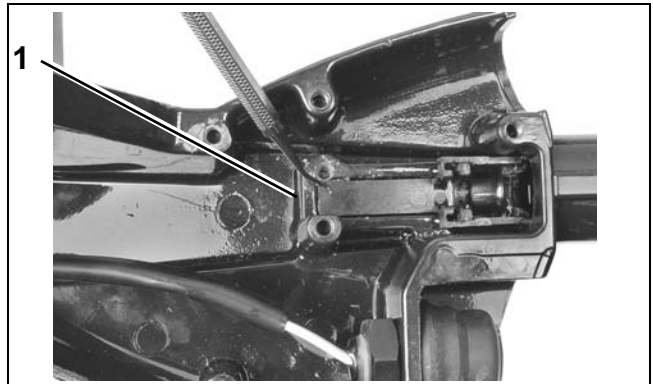

1. Back of flange

006682

Apply *Nut Lock* on the screw threads, install the washer and screw.

**IMPORTANT:** Turn self-tapping screw counter-clock-wise until threads of screw engage threads of screw boss. Failure to follow this procedure will damage the screw boss threads. Once threads are engaged, tighten screw so that there is no space between tab, washer and screw. Top of tab **MUST** be flush with top of flange.

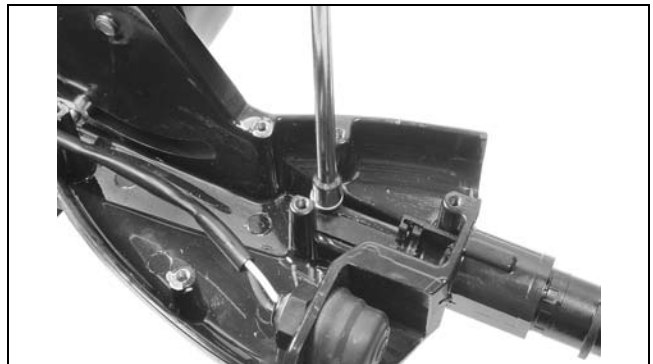

006681

Install the throttle control plate on outer handle.

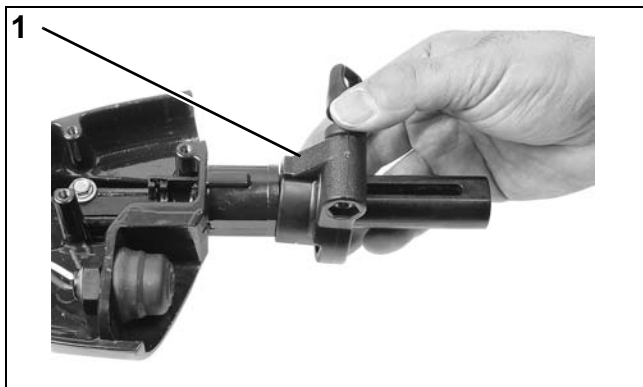

1. Throttle friction control 006671

Install trim switch wiring through inner steering handle.

**IMPORTANT:** Trim switch wiring must NOT be twisted through the throttle twist grip or inner tiller handle / wire guide.

Insert wire guide into inner steering handle.

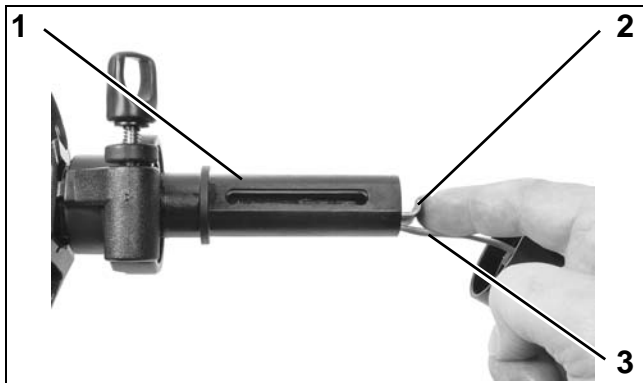

1. Inner tiller handle  
2. Wire guide  
3. Trim switch wires 006726

Wire guide should slide easily into place. If any binding is felt, inspect trim switch wiring for twist-

ing. If wire guide is forced into place, it WILL damage trim switch wiring.

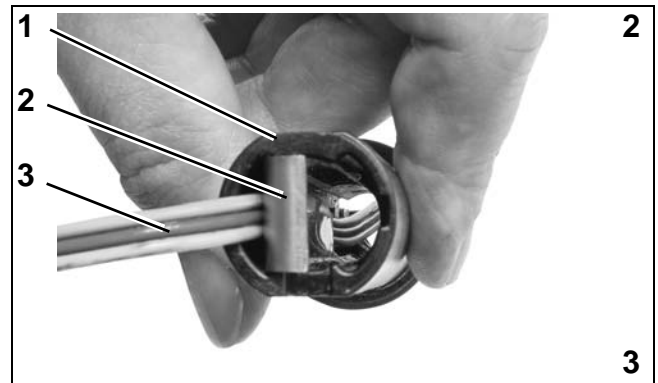

1. Inner tiller handle  
2. Wire guide  
3. Trim switch wires 006684

Make sure trim switch wiring is NOT twisted before proceeding.

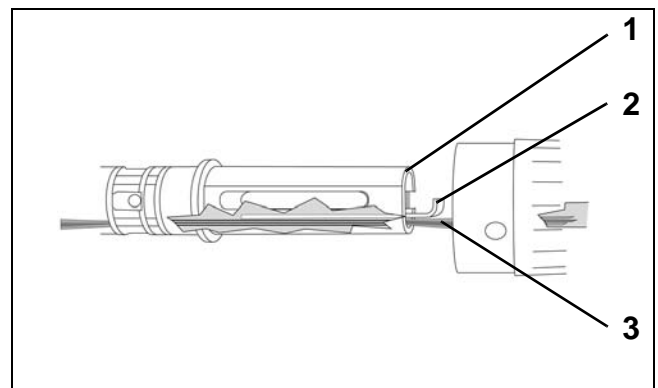

1. Inner tiller handle  
2. Wire guide  
3. Trim switch wires 006675

## MIDSECTION

### TILLER HANDLE SERVICE – LONG HANDLE

Install the handle end of the throttle cable. Snap the throttle cable trunnion into the recess in the handle. Install the retainer clip.

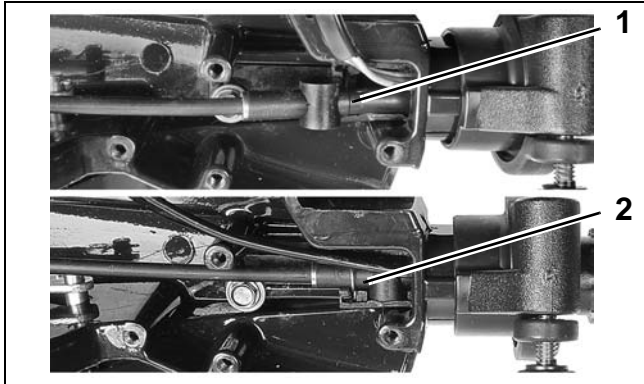

1. Throttle cable trunnion 006683  
2. Retainer

Place the guides over the roller pin and into the slots of the inner handle. Place the rollers on the ends of the roller pin.

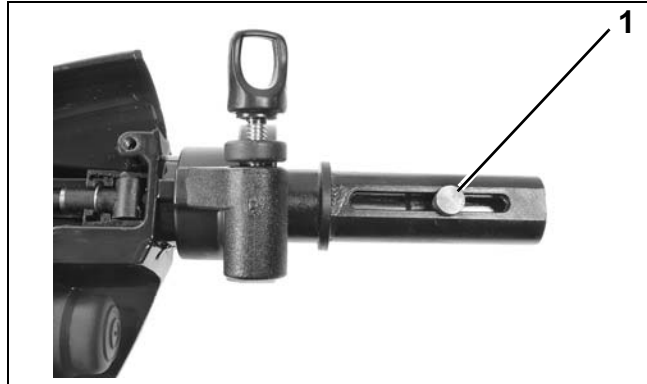

1. Roller 006670

Push the throttle cable pin through the end of the throttle cable.

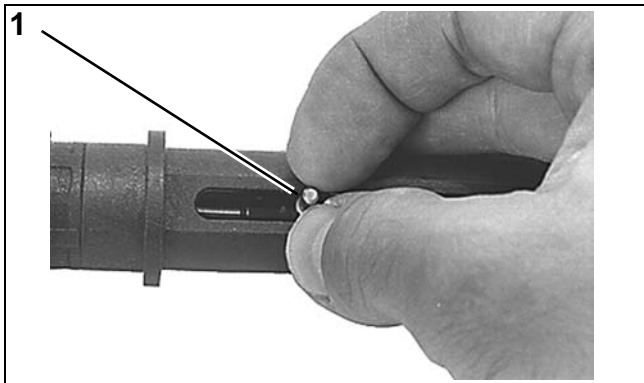

1. Pin 006712

Assemble the helix halves on the handle and slide the grip over the helix.



006718

Lubricate end of the pin, guides, rollers, helix halves, and inner handle guide slot with *Moly Lube*.

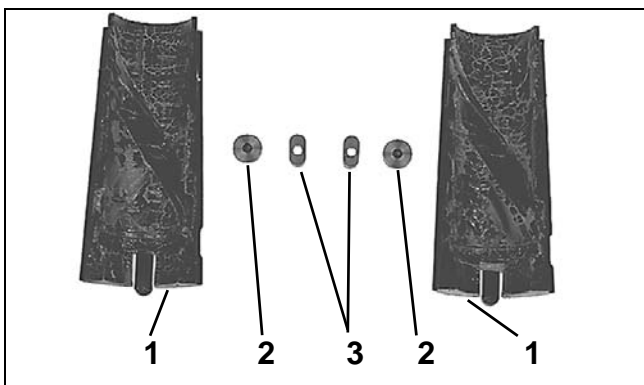

1. Helix halves COA2674  
2. Rollers  
3. Guides

Carefully pull trim switch wires through inner tiller handle as twist grip assembly is installed.



1. Trim switch wiring 006677

Install trim switch connector. Refer to **CONNECTOR SERVICING** on p. 116.



Be sure the twist-grip's speed indicator line is positioned with the speed range symbol on the handle. Snap the grip into place.

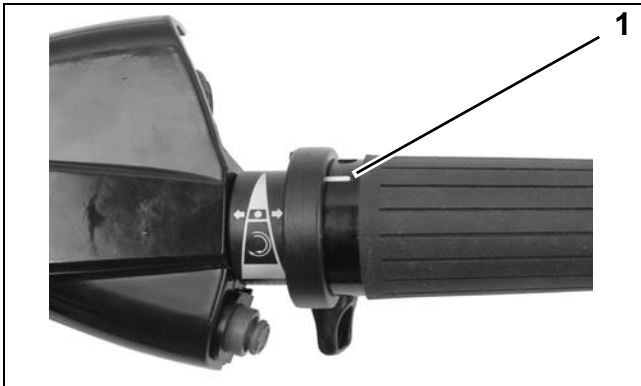

1. Indicator line 006719

Install stop switch assembly and connect to harness.

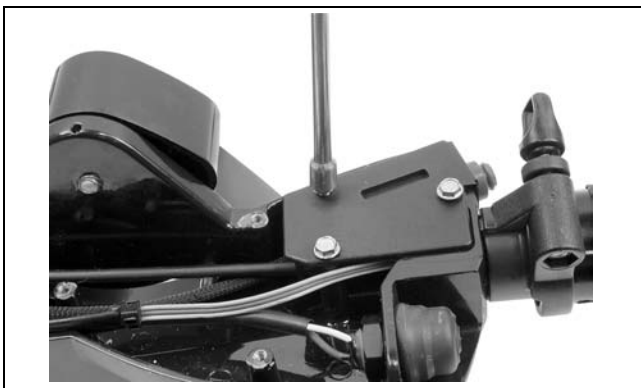

006713

Install bottom cover of tiller handle with seven screws.

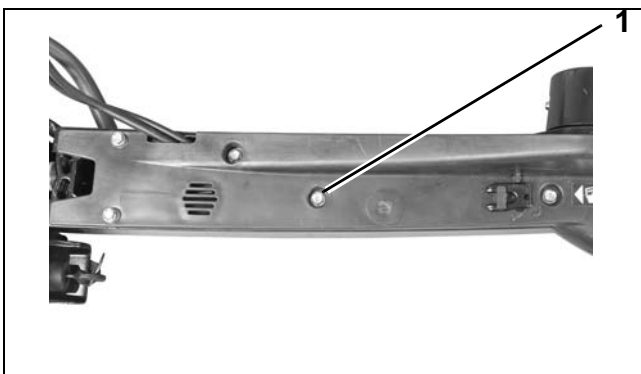

1. Cover screw 006566

### Installation

The steering arm can be positioned straight, or angled 15° port or starboard by moving the adjustment plate.

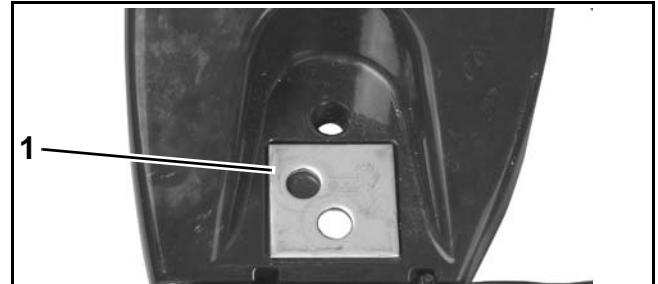

1. Plate adjustment for tiller in CENTER position. 005083

Place tiller bracket on steering arm from the bottom. Thread steering arm screws, with washers, into steering arm and tighten to a torque of 18 to 20 ft.lbs. (24.5 to 27 N·m).

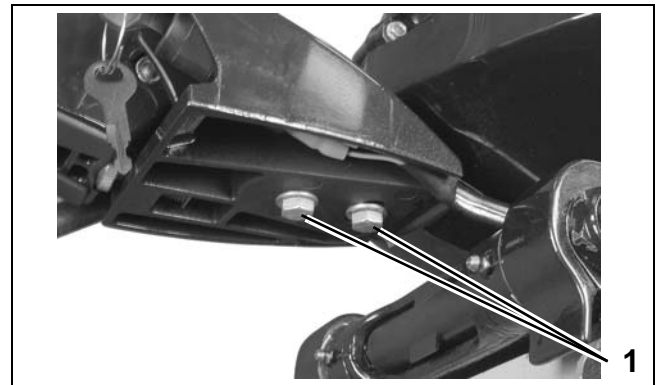

1. Screw 006361

Install locknuts on screws on top of steering arm. Hold screws with wrench and tighten locknuts to a torque of 18 to 20 ft.lbs. (24.5 to 27 N·m).

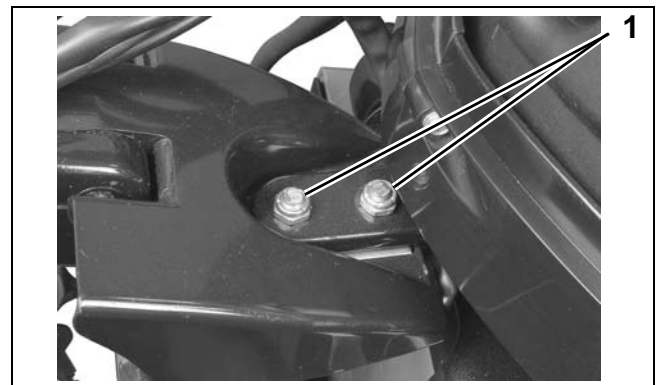

1. Screw 006362

## MIDSECTION

### TILLER HANDLE SERVICE – LONG HANDLE

Route shift and throttle cables and electrical harness through grommet in lower motor cover. Connect harness to engine wiring harness.

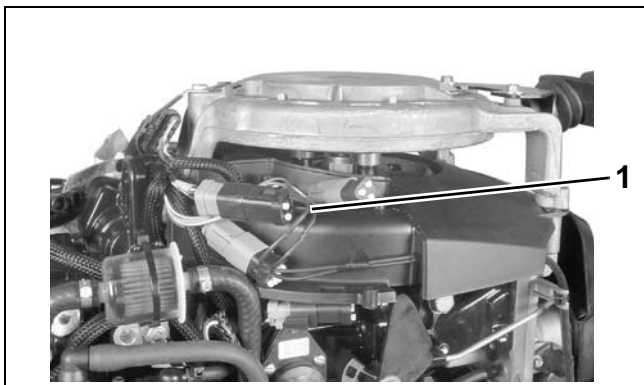

#### Rope Start models

1. Electrical harness connector

002511

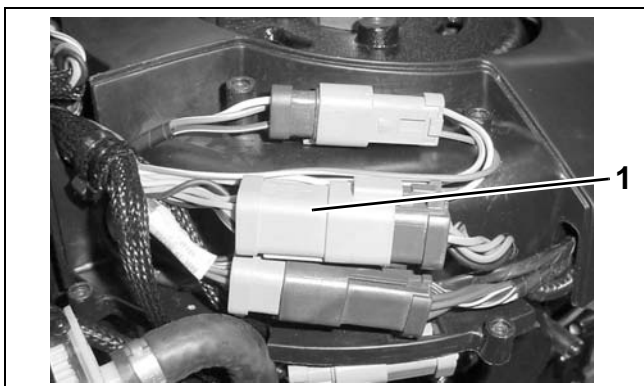

#### Tiller Electric models

1. Electrical harness connectors

001999

Use tie strap to secure harness to throttle body bracket.

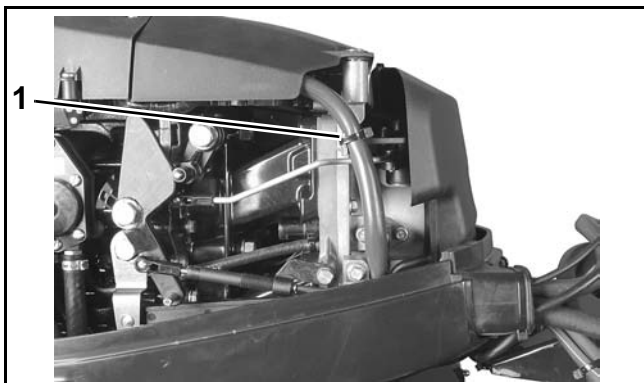

1. Bracket

006314

## Control Cable Installation

**IMPORTANT:** DO NOT complete final attachment of cables to shift and throttle levers until all cables, wires, and hoses have been routed and grommet has been placed into the lower engine cover.

### Shift Cable Adjustment

Pull firmly on shift cable casing to remove backlash. With outboard and tiller handle shift lever in NEUTRAL, place the cable trunnion into the lower anchor pocket. Adjust the trunnion nut so the casing fits onto the shift lever pin.

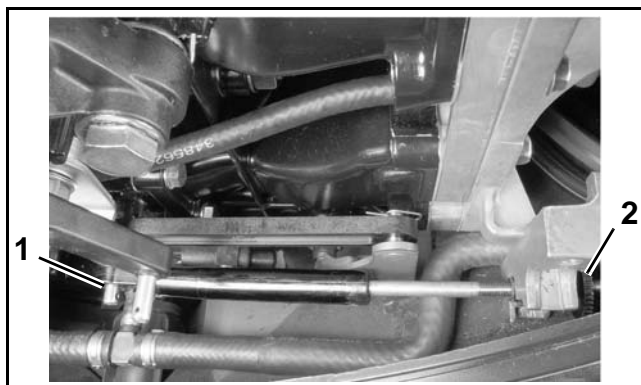

1. Shift lever pin  
2. Trunnion nut

002100

Secure shift cable to the shift lever pin. For proper installation, review the following steps:

- Place washer on pin.
- Position retainer clip with straight section on the bottom and angled section on the top.
- Use long nose pliers to insert straight section of clip into linkage pin hole.
- Push the clip towards the hole while lifting on the curved end with the pliers.
- Be sure retainer clip fully engages the pin.
- Lock the retainer by moving the angled section **behind** the straight section.



#### Locked Retainer Clip

1. Angled section behind straight section

DP0817a

### Throttle Cable Adjustment

Place throttle cable in position. Use Ball Socket Installer tool, P/N 342225, to snap throttle cable connector onto throttle lever.



1. Installer tool

005106

Place throttle cable in upper anchor pocket. Install cable retainer on anchor block.

Hold twist grip in full SLOW position. Pull firmly on cable to remove backlash.

Adjust cable anchor so throttle cam is against idle stop when anchor screw aligns with throttle body boss. Then, rotate anchor four turns toward the end of the cable.

Install washer, cable anchor, and cable anchor screw on throttle body boss. Tighten screw securely.

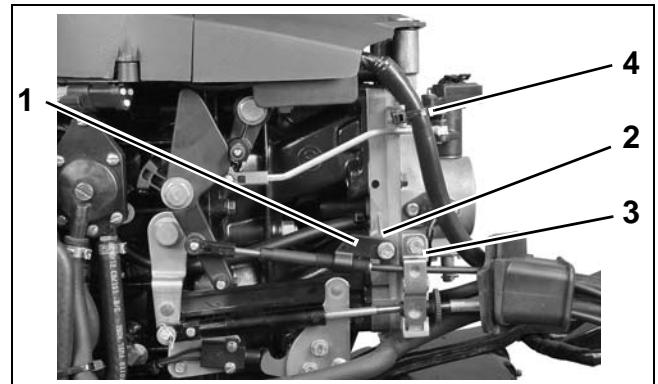

1. Cable anchor
2. Boss
3. Cable retainer
4. Tie strap

006745

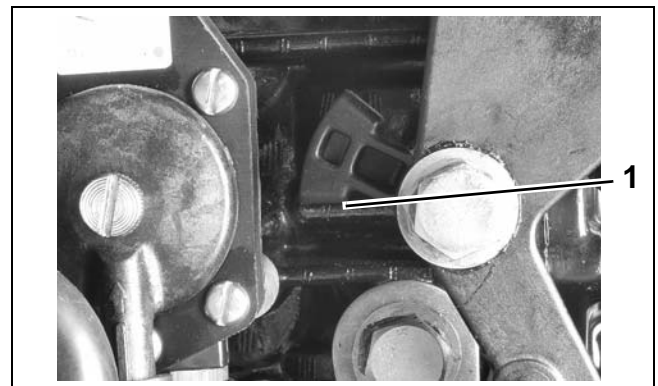

1. Throttle lever stop

005114



1. Turn anchor four turns toward cable end.

006564

**IMPORTANT:** Rotate twist grip. Make sure throttle cam goes to full throttle without bending cable, and still returns to IDLE stop.



# GEARCASE

## TABLE OF CONTENTS

SERVICE CHARTS .....	290
GEARCASE TYPES, 75 – 90 HP .....	293
PROPELLER SERVICE .....	293
GEARCASE LEAK TEST .....	295
<b>GEARCASE SERVICE, 40 – 65 HP MODELS</b>	
GEARCASE REMOVAL AND INSTALLATION .....	296
WATER PUMP SERVICE .....	298
SHIFT ROD ADJUSTMENT .....	300
GEARCASE DISASSEMBLY .....	301
PRE-DISASSEMBLY INSPECTION .....	301
PROPELLER SHAFT BEARING HOUSING REMOVAL .....	302
PINION GEAR AND DRIVESHAFT REMOVAL .....	303
SHIFT HOUSING, GEAR AND PROPELLER SHAFT REMOVAL .....	304
SHIFTER, BEARING AND SEAL SERVICE .....	305
DRIVESHAFT SHIMMING .....	312
GEARCASE ASSEMBLY .....	313
SHIFT HOUSING, GEAR, AND PROPELLER SHAFT INSTALLATION .....	313
SHIFT ROD HOUSING INSTALLATION .....	313
PINION GEAR AND DRIVESHAFT INSTALLATION .....	314
PROPELLER SHAFT BEARING HOUSING AND GEAR INSTALLATION .....	316
FINAL ASSEMBLY AND ADJUSTMENT .....	317
<b>GEARCASE SERVICE, 75 – 90 HP MODELS</b>	
GEARCASE REMOVAL AND INSTALLATION .....	318
WATER PUMP SERVICE .....	320
SHIFT ROD ADJUSTMENT .....	323
GEARCASE DISASSEMBLY .....	324
PRE-DISASSEMBLY INSPECTION .....	324
PROPELLER SHAFT BEARING HOUSING REMOVAL .....	325
PINION GEAR AND DRIVESHAFT REMOVAL .....	325
DRIVESHAFT SERVICE .....	327
SHIFT HOUSING, GEAR AND PROPELLER SHAFT REMOVAL .....	328
WATER INTAKE SCREENS .....	328
GEARCASE HOUSING INSPECTION .....	328
SHIFTER, BEARING AND SEAL SERVICE .....	329
DRIVESHAFT SHIMMING .....	337
GEARCASE ASSEMBLY .....	338
WATER INTAKE SCREENS .....	338
SHIFT HOUSING, GEAR, AND PROPELLER SHAFT INSTALLATION .....	338
SHIFT ROD HOUSING INSTALLATION .....	339
PINION GEAR AND DRIVESHAFT INSTALLATION .....	340
PROPELLER SHAFT BEARING HOUSING AND GEAR INSTALLATION .....	341
FINAL ASSEMBLY AND ADJUSTMENT .....	342



**“S”-TYPE GEARCASE**

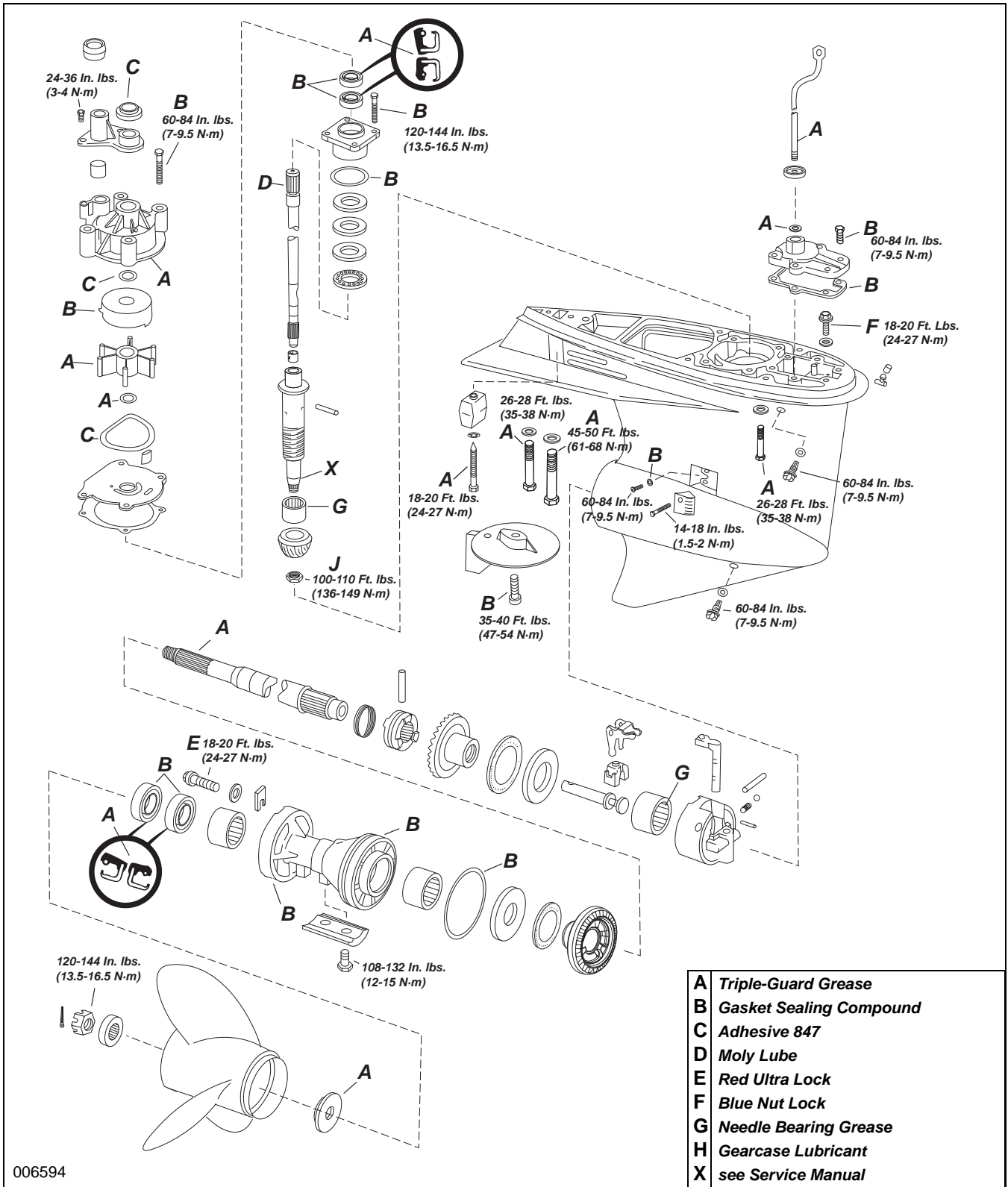

006594

# GEARCASE SERVICE CHARTS

## "O"-TYPE GEARCASE – STANDARD ROTATION

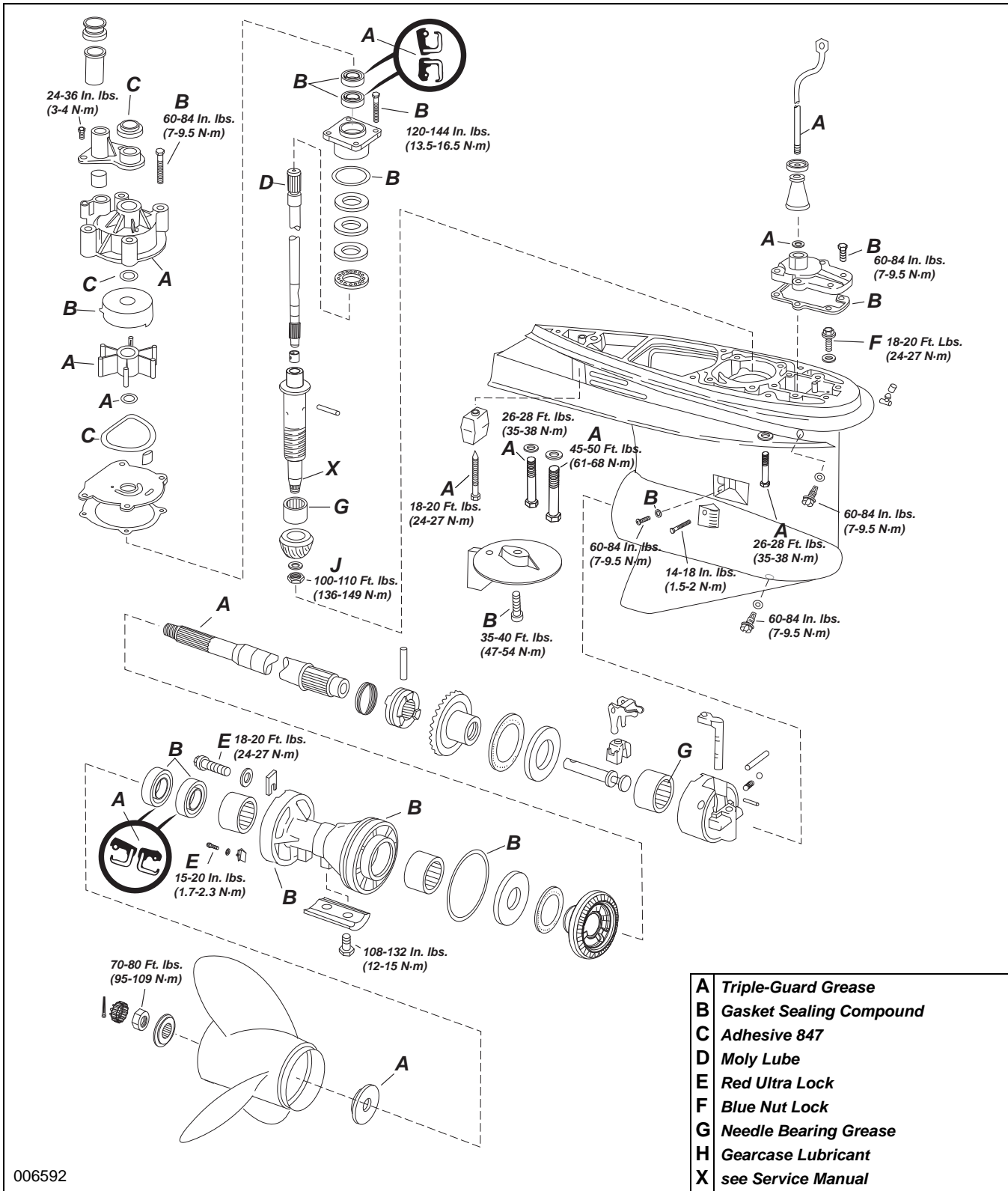

006592



## GEARCASE TYPES, 75 – 90 HP

Outboard Model	Gearcase Type	General Comparison	Service Procedure Comparison
(L) Models with 20 in. shaft	“S”	Unique housing, shafts, gears, and bearings	Similar
(X) Models with 25 in. shaft	“O”	Unique housing, shafts, gears, and bearings	

## PROPELLER SERVICE

### Inspection

Carefully examine propeller and outboard for the following:

- Damaged blades and signs of propeller cavitation (burned paint, etc.)
- Spun or overheated inner hub
- Worn or twisted splines and inadequate lubricant
- Damaged or missing converging ring (if applicable)
- Damage to outer hub area
- Worn, missing, or incorrect thrust washer and spacer
- Correct size and style
- Check for bent or damaged propeller shaft and twisted splines.

Refer to **Propeller Hardware Installation** on p. 294.

### **⚠ WARNING**

When servicing the propeller, always shift the outboard to **NEUTRAL**, turn the key switch **OFF**, and disconnect the battery positive (+) cable so the outboard cannot be started accidentally.

### Propeller Selection

#### **⚠ CAUTION**

Selection of the wrong propeller could reduce engine service life, affect boat performance, or cause serious damage to the powerhead.

Water testing with various propeller designs and sizes is the best method of propeller selection.

The correct propeller, under normal load conditions, will allow the engine to run near the midpoint of the RPM operating range at full throttle. Refer to **SERVICE SPECIFICATIONS** on p. 10.

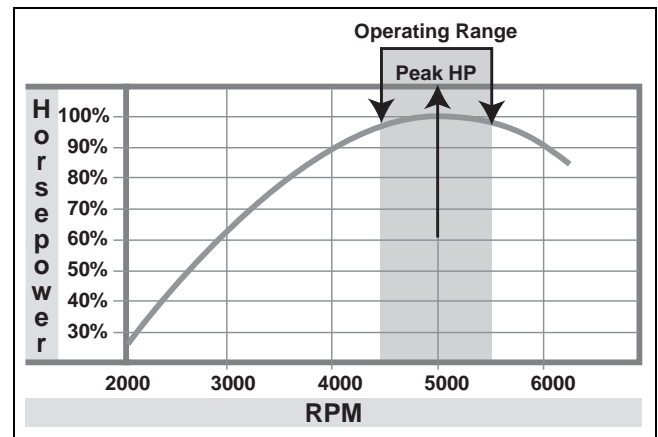

**NOTICE** If the propeller blades have too much pitch, the engine will operate below its normal range at full throttle. Power will be lost, and powerhead damage could occur. If the propeller blades have too little pitch, the engine will operate above its normal range and damage from overspeeding could occur.

## GEARCASE PROPELLER SERVICE

When selecting a propeller, consider the following:

- Use an accurate tachometer to determine the engine's full-throttle RPM.
- The outboard should be trimmed for top speed.
- Select a propeller that suits the customer's application and allows the engine to run near the midpoint of the full-throttle operating range when the boat has a normal load.
- Occasionally, one propeller will not cover a wide range of boat applications — water skiing to high speed performance boating. In such cases, it might be necessary to have a propeller for each situation.
- Refer to the *Evinrude/Johnson Genuine Parts and Accessories Catalog* for propeller styles and sizes.
- Right-hand propellers are considered standard rotation propellers. When propelling a boat forward, the propeller rotates in a right-hand (clockwise) direction as viewed from the rear.
- Left-hand propellers are considered counter-rotation propellers. When propelling a boat forward, the propeller rotates in a left-hand (counterclockwise) direction as viewed from the rear.

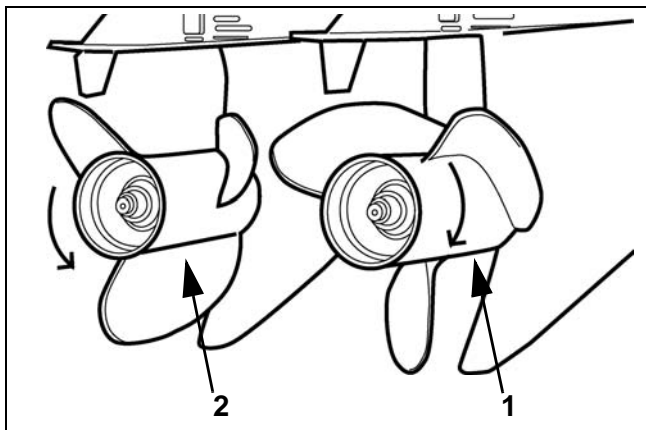

1. Right-hand rotation (clockwise)
2. Left-hand rotation (counterclockwise)

000033

### WARNING

**For dual-outboard installations, always check to be sure propellers are installed on the correct engines before aggressively operating the boat.**

## Propeller Hardware Installation

### WARNING

**To prevent accidental starting while servicing, twist and remove all spark plug leads.**

**IMPORTANT:** Depending on propeller style, different thrust bushings, spacers, and cotter pin keepers are used. See the *Evinrude/Johnson Genuine Parts and Accessories Catalog* for correct propeller hardware.

Apply *Triple Guard* grease to the entire propeller shaft before installing the propeller.

Install thrust bushing onto propeller shaft with taper of bushing matching taper of shaft.

If installing a propeller with an interchangeable hub, assemble the propeller following instructions provided with the propeller.

Align splines of propeller and shaft. Push propeller until seated on the thrust bushing.

Install the spacer over the propeller shaft splines.

Wedge a block of wood between propeller blade and the anti-ventilation plate.

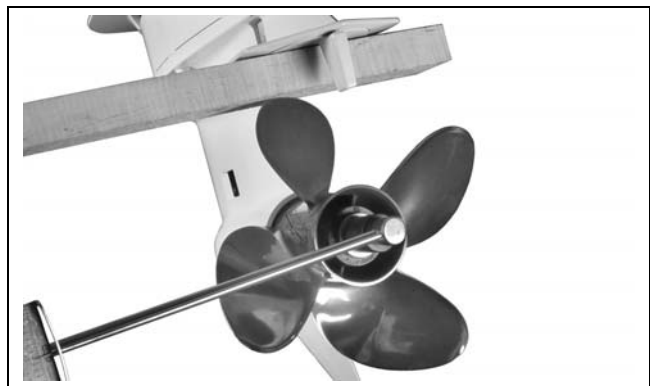

001992

Install the propeller nut and tighten to a torque of:

- With Keeper – 70 to 80 ft. lbs. (95 to 109 N·m)
- Without Keeper – 120 to 144 in. lbs. (13.6 to 16.3 N·m)

If cotter pin holes in the nut (without keeper) and shaft do not align, tighten further. Do not loosen.

Install keeper (if applicable). Install new cotter pin.

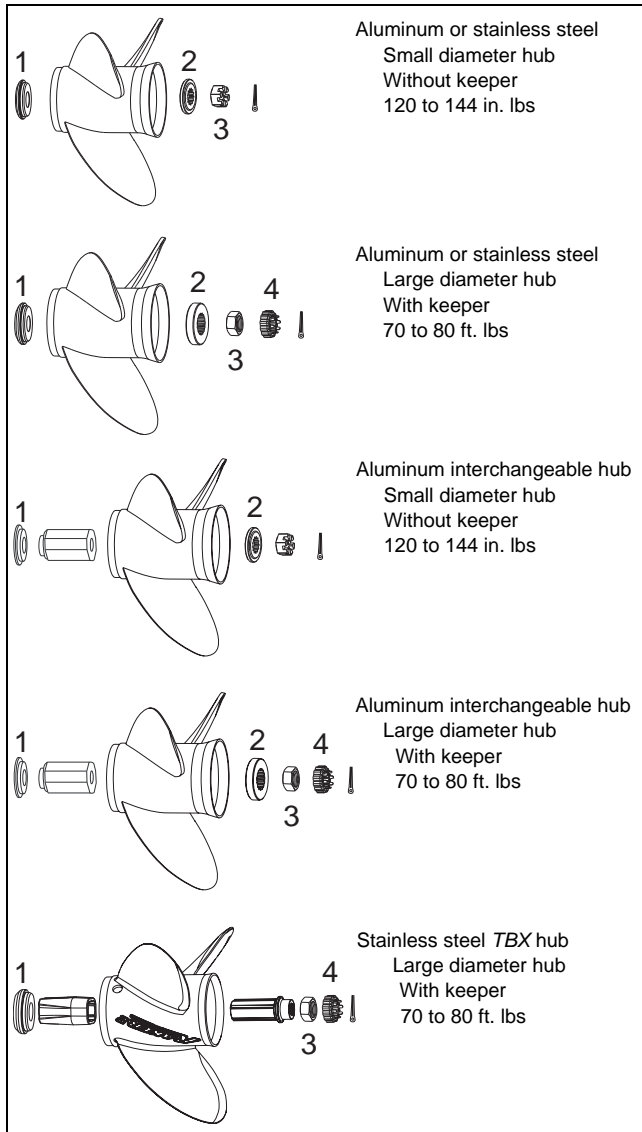

1. Thrust bushing
2. Spacer
3. Propeller nut
4. Keeper

008057

**IMPORTANT:** After installation, make sure outboard is in NEUTRAL and carefully spin propeller. Propeller must turn freely and should not spin off center. If propeller appears to wobble, check for possible bent propeller shaft.

## GEARCASE LEAK TEST

Drain lubricant before testing.

Use Gearcase Pressure Tester, P/N 507977. Install lubricant drain/fill plug and seal, thread pressure test gauge fitting and seal in lubricant level hole.

Pressurize 3 to 6 psi (21 to 42 kPa).

If pressure gauge indicates leakage, submerge the gearcase in water to determine source of leak.

If the gauge does not indicate leakage, increase pressure to 16 to 18 psi (110 to 124 kPa). Check for leaks.

Make necessary repairs and repeat test.

Install Gearcase Vacuum Tester, P/N 507982. Apply 3 to 5 in. of vacuum (76 to 127 mm) Hg. with pump.

If vacuum gauge indicates leakage, apply oil around suspected seal. If leak stops or oil is drawn in, seal is defective.

Repeat test, gearcase must hold minimum of 15 in. vacuum (381 mm) Hg.



002388

# GEARCASE REMOVAL AND INSTALLATION

## Gearcase Removal

**⚠ WARNING**

To prevent accidental starting while servicing, twist and remove all spark plug leads.

During service, the outboard may drop unexpectedly. Avoid personal injury; always support the outboard's weight with a suitable hoist or the tilt support bracket during service.

Remove pin and washer from shift rod lever to release the lower shift rod.



1. Shift rod screw

002171

Note where the index mark on the gearcase aligns with the index number of the adjustable trim tab so the trim tab can be installed in the same position. Remove the trim tab retaining screw and trim tab from the gearcase.

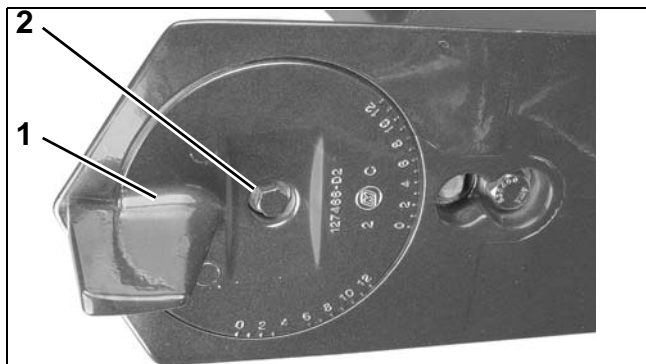

1. Trim tab  
2. Trim tab retaining screw

001996

Remove the 5/16-18 x 1.25 in. screw and washer, and remove 7/16-14 x 3.5 in. screw and washer.

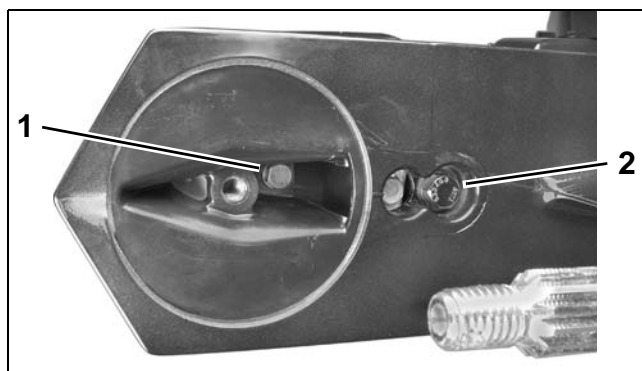

1. 5/16-18 x 1.25 in. screw  
2. 7/16-14 x 3.5 in. screw

001995

Remove the four 3/8-16 x 1.5 in. gearcase retaining screws and washers.

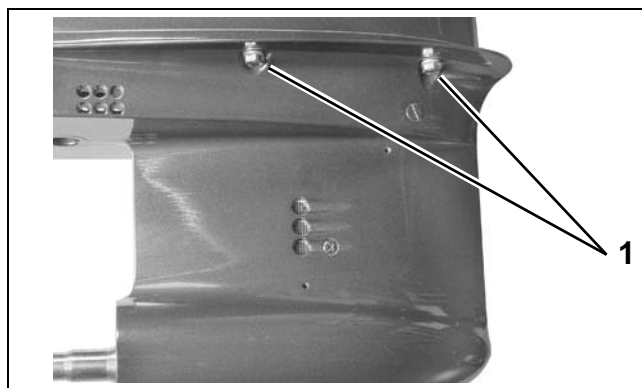

1. Gearcase retaining screws

001994

Remove the gearcase assembly from the exhaust housing, being careful not to bend the shift rod.

## Gearcase Installation

**⚠ WARNING**

During service, the outboard may drop unexpectedly. Avoid personal injury; always support the outboard's weight with a suitable hoist or the tilt support bracket during service.

**NOTICE** Before installing gearcase, shift rod adjustment **MUST** be checked. Refer to **SHIFT ROD ADJUSTMENT** on p. 300.

Coat the driveshaft splines with *Moly Lube*. DO NOT coat top surface of the driveshaft because lubricant may prevent seating of the driveshaft in the crankshaft.

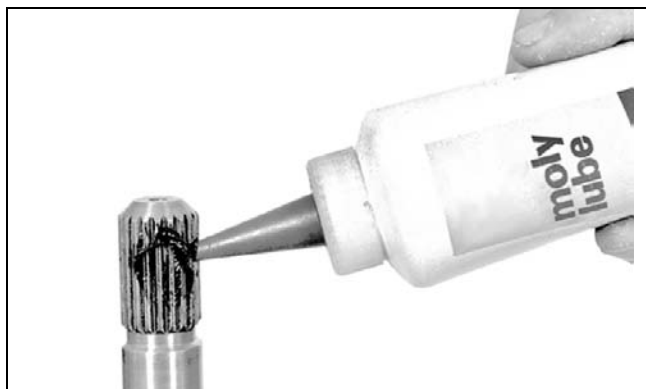

30385

Apply *Adhesive 847* to the exhaust housing seal's outer surface. Place the seal in the gearcase exhaust cavity. Apply *Triple-Guard* grease to the seal's inner surfaces.

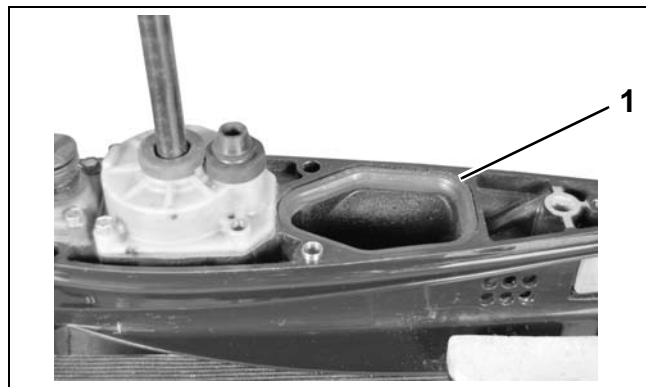

1. Exhaust housing seal

008354

Slide the gearcase into place, making sure:

- Driveshaft engages the crankshaft.
- Inner exhaust housing installs correctly.
- Shift rod does not turn and is positioned properly in the shift rod lever below the crankcase.

Apply *Triple-Guard* grease to threads of the gearcase retaining screws. Tighten the screws to a torque of:

- **3/8 in.** screws – 18 to 20 ft. lbs. (24 to 27 N·m)
- **7/16 in.** screw – 28 to 30 ft. lbs. (38 to 40 N·m)
- **5/16 in.** screw – 10 to 12 ft. lbs. (13.5 to 16 N·m)

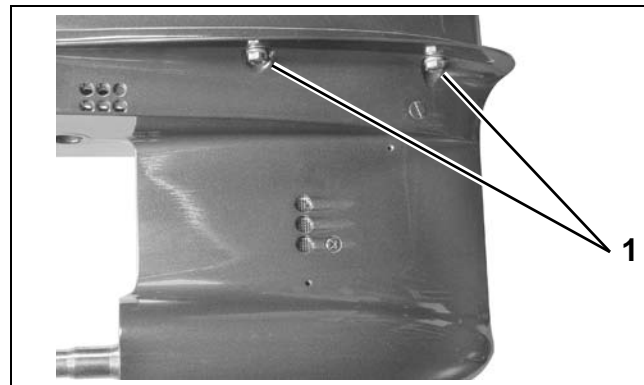

1. 3/8 in. screws

001994

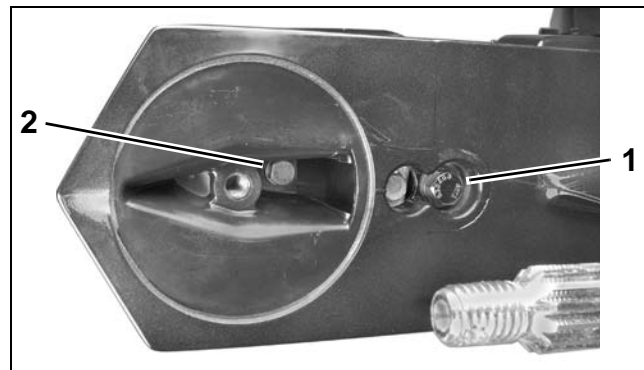

1. 7/16 in. screw

2. 5/16 in screw

001995

Apply *Triple-Guard* grease to threads of the trim tab screw. Install and align the trim tab with the index marks noted prior to disassembly. Tighten the trim tab screw to a torque of 35 to 40 ft. lbs.

## GEARCASE SERVICE, 40 – 65 HP MODELS

### WATER PUMP SERVICE

(47 to 54 N·m). For adjustment, refer to **Trim Tab Adjustment** on p. 31.

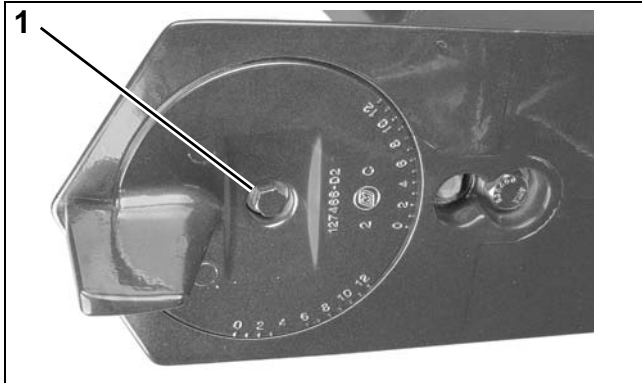

1. Trim tab screw

001996

Place the shift rod in the shift rod lever. Install the retaining pin and washer. Tighten pin to a torque of 60 to 84 in. lbs. (7 to 9.5 N·m).



1. Shift rod screw

002171

#### **WARNING**

**To prevent loss of operator control, check for proper shifting operation and adjust, if necessary.**

**IMPORTANT:** During break-in period of a reassembled gearcase, change the gearcase lubricant between 10 to 20 hours of operation.

## WATER PUMP SERVICE

### Disassembly

Remove the four impeller housing screws.

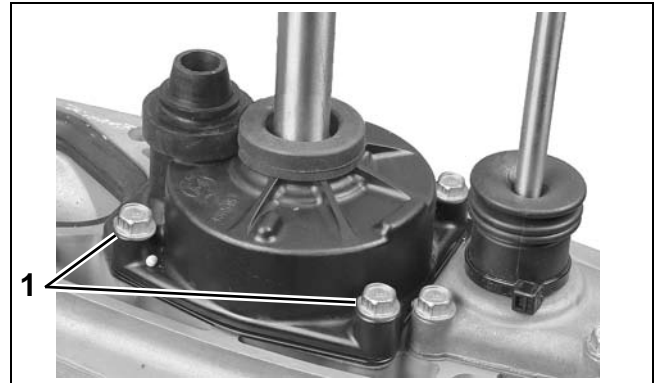

1. Impeller housing screws

001203

Slide the water pump off the driveshaft. Remove the impeller key, impeller plate, and gasket. Discard the gasket.

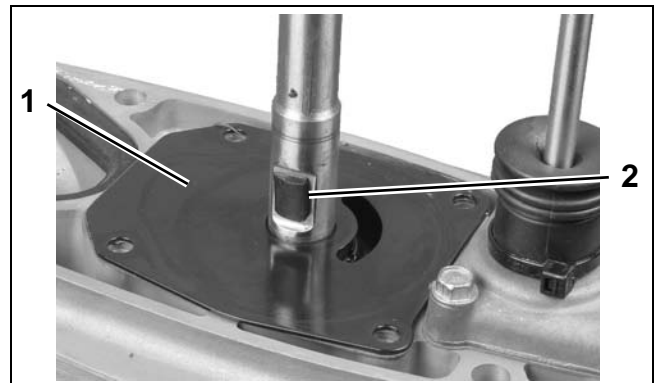

1. Impeller plate  
2. Drive key

001214

Remove all the parts from the housing.

### Inspection

Check impeller for overheating, hub separation, and other wear or damage.

Check liner and wear plate for scoring, distortion, and impeller material transfer.

Inspect the housing for cracks or melting.

Make sure gasket surface is clean and smooth.

## Assembly

Lightly coat the exterior rim of the impeller cup with *Gasket Sealing Compound*. Install the cup in the impeller housing. The cup locks in place in the housing with a square index tab.



1. Index tab

001215

**IMPORTANT:** Do not allow any sealer to get into the air bleed groove in the impeller housing. If this groove is blocked by adhesive, the pump will lose its prime and will not pump water.

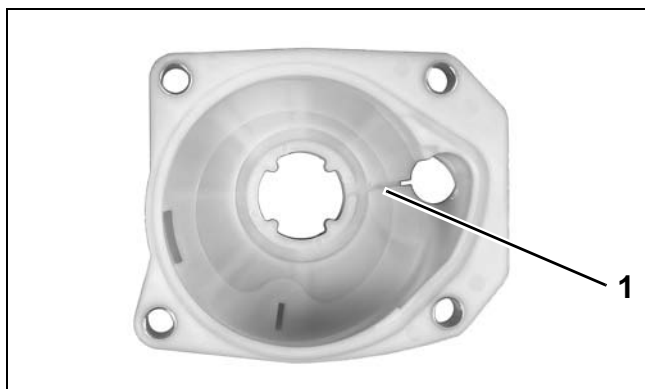

1. Air bleed groove

006415

Lightly coat the inside of the liner with *Triple-Guard* grease. With a counterclockwise rotation, install the impeller into the liner with the slot for the impeller key facing out.

Apply a thin bead of *Adhesive 847* in the seal groove, and install the special shaped O-ring seal.

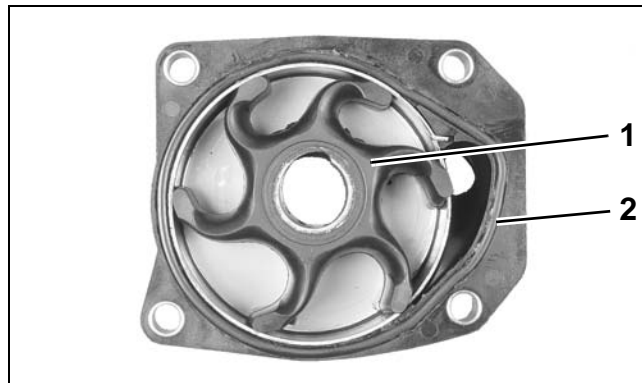

1. Impeller  
 2. O-ring seal

001216

Apply *Gasket Sealing Compound* to both sides of a new impeller plate gasket. Install the gasket and impeller plate.

Apply *Triple-Guard* grease to temporarily hold drive key in place.

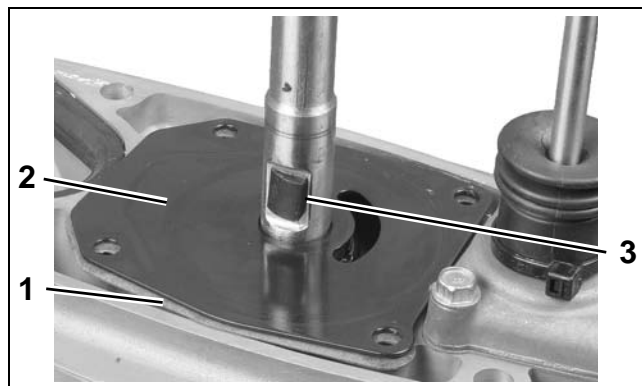

1. Impeller plate gasket  
 2. Impeller plate  
 3. Drive key

001217

The sharp edge of the key is the leading edge in clockwise rotation.

Slide the water pump down the driveshaft. Align impeller slot with the impeller key. Rotate the driveshaft to engage the key with the impeller, and

## GEARCASE SERVICE, 40 – 65 HP MODELS

### SHIFT ROD ADJUSTMENT

slide water pump down over key. Be sure impeller key does not fall out of position.

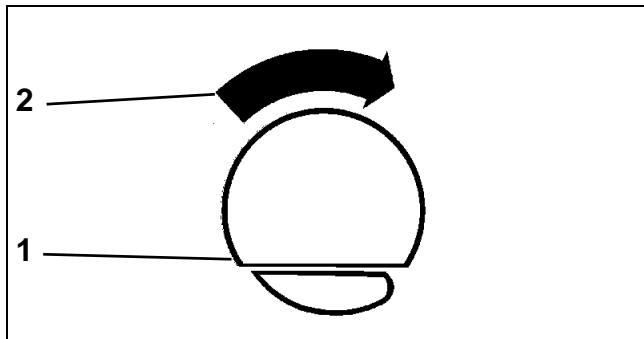

1. Sharp edge of drive key
2. Direction of driveshaft rotation

CO2995

**NOTICE** Make sure the impeller engages the impeller key. Serious powerhead damage will result if impeller key is not in place.

Align the impeller housing with the gearcase. Apply *Gasket Sealing Compound* to threads of the four impeller housing screws. Install the screws and tighten to a torque of 60 to 84 in. lbs. (7 to 9.5 N-m).

Install the water tube grommet on the impeller housing.

Apply a thin bead of *Adhesive 847* to groove of the impeller housing grommet. Install the grommet on the impeller housing.

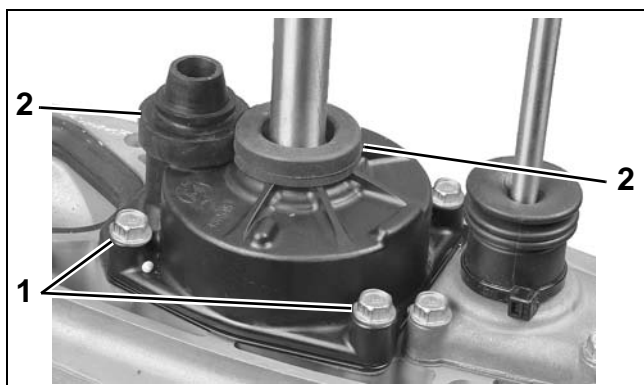

1. Housing screws
2. Water tube grommet
3. Impeller housing grommet

001203

**NOTICE** Before installing gearcase, shift rod adjustment **MUST** be checked. Refer to **SHIFT ROD ADJUSTMENT** on p. 300.

## SHIFT ROD ADJUSTMENT

Check the shift rod height from the shift rod hole to the surface of the gearcase using Universal Shift Rod Height Gauge, P/N 389997.

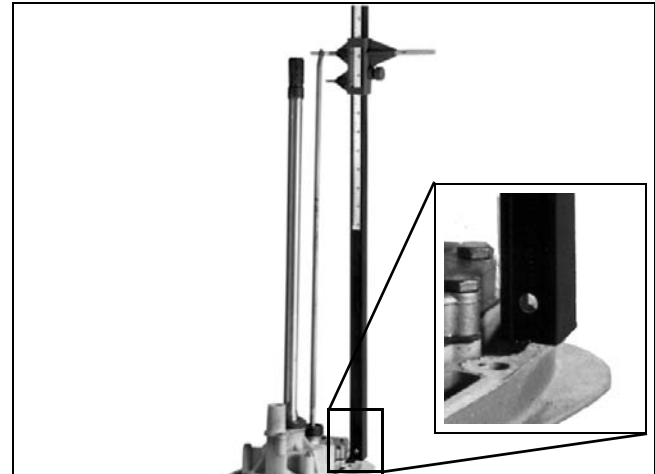

COA6166

With the gearcase in NEUTRAL, rotate the shift rod up or down as necessary for correct adjustment. Once correct height is achieved, rotate rod one half turn or less to direct offset to the rear.

Shift Rod Height:

- 21.38 in. (543 mm)  $\pm$  One-Half Turn



# GEARCASE DISASSEMBLY

## Pre-Disassembly Inspection

### WARNING

Wear safety glasses to avoid personal injury, and set compressed air pressure to less than 25 psi (172 kPa).

**IMPORTANT:** Clean and inspect all parts during disassembly. Replace any damaged parts, seals, O-rings, and gaskets.

Remove the propeller and mounting hardware.

Drain and inspect oil as described in **Gearcase Lubricant** on p. 39.

Remove gearcase. Refer to **GEARCASE REMOVAL AND INSTALLATION** on p. 296.

Remove water pump. Refer to **WATER PUMP SERVICE** on p. 298.

Before disassembling the gearcase, examine the following:

- **Gearcase Housing** — Check for visible damage to skag, strut, anti-ventilation plate, bullet, and mating surface. Check seal areas for visible signs of lubricant leakage.
- **Propeller Shaft** — Check for bent or damaged shaft. Check for twisted splines and damaged threads.
- **Shift Rod** — Check for misadjusted, bent, or binding rod. A misadjusted shift rod height can cause shift difficulty, loss of boat and outboard control, and gearcase damage.

- **Hydrostatic Seal Grooves** — Must be in good condition to help prevent propeller ventilation.

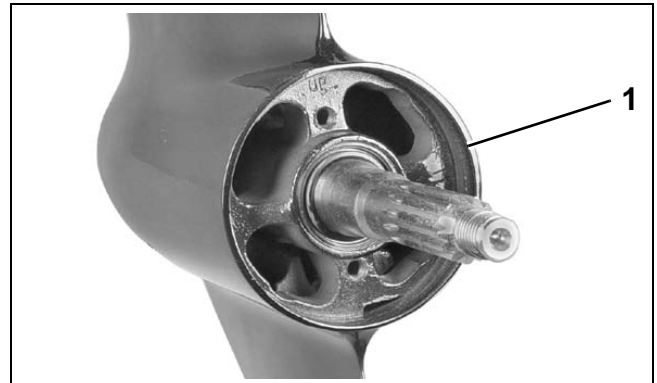

1. Hydrostatic seal grooves

002217

- **Gearcase Anodes** — If anodes have eroded to two-thirds their original size, they must be replaced.



1. Gearcase anode

002014

- **Drive Shaft** — Check splines for visible damage, twisting and wear. Severe spline wear indicates the exhaust housing or gearcase has been distorted, possibly by impact damage.
- **Water Intake Screens** — Check for damage and blockage. If screens cannot be cleaned, they must be replaced. Different screens are available and should not be mixed. Refer to correct model parts manual for listing and description.

## GEARCASE SERVICE, 40 – 65 HP MODELS

### GEARCASE DISASSEMBLY

#### Propeller Shaft Bearing Housing Removal

Use a 5/16 in. thin wall socket to remove the four screws with O-rings holding the propeller shaft bearing housing.

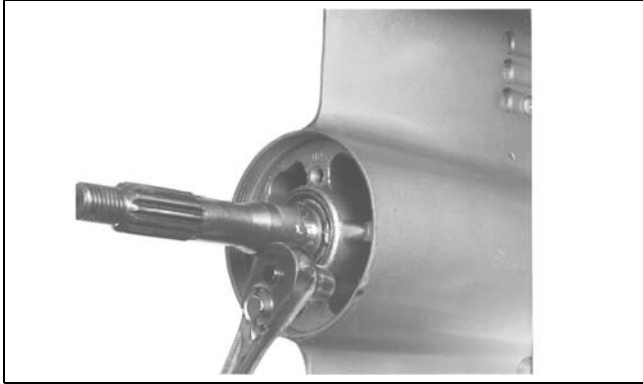

COA3571

Remove the propeller shaft bearing housing from the gearcase using the following:

- Puller body, screw, and handle from Universal Puller Set, P/N 378103.
- Two 5/16-18 x 8 in. screws, P/N 316982, from Universal Puller Set, P/N 378103.



9437

Remove the two retaining rings using Retaining Ring Pliers, P/N 331045.

#### **⚠ CAUTION**

Retaining rings are under extreme pressure during removal and installation. To prevent personal injury, wear safety glasses and proceed with care to avoid unsnapping the ring from the pliers. After the retaining rings are removed far enough from the gearcase to clear the housing, release the tension on the pliers while retaining ring is still around the propeller shaft.

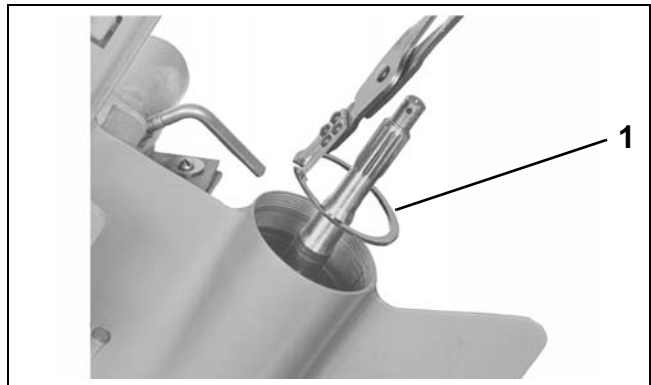

1. Retaining ring

9438

Remove the retainer plate from the gearcase.

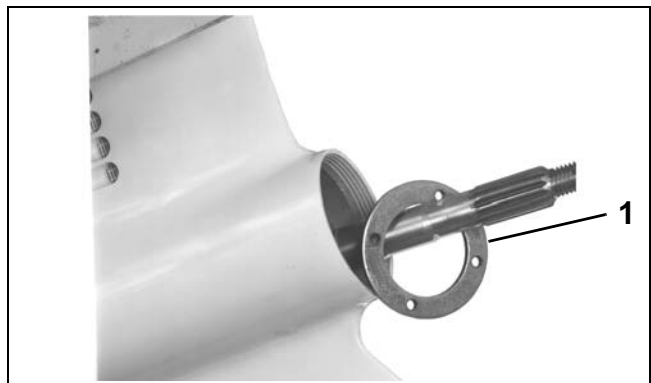

1. Retainer plate

COA3513

Remove the larger thrust washer, thrust bearing, and reverse gear from the gearcase. Remove the smaller thrust washer located in front of the gear.

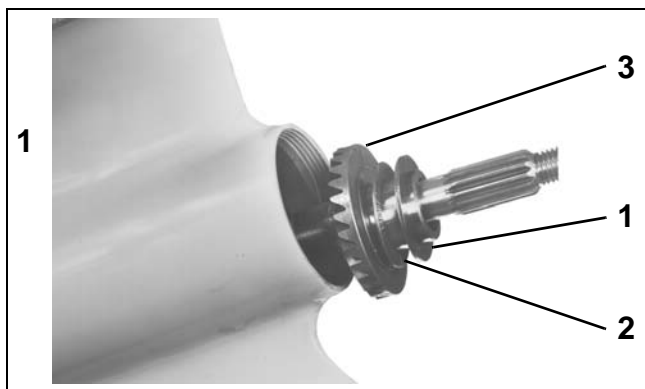

1. Larger thrust washer
  2. Thrust bearing
  3. Reverse gear
- COA3514

## Pinion Gear and Driveshaft Removal

Adjust the shift rod to move the clutch dog as far forward as possible. This will help ease removal of the pinion nut.

Use Driveshaft Holding Socket, P/N 334995, and an 11/16 in. open-end wrench to loosen and remove the pinion nut from the bottom of the driveshaft. Pad handle of the wrench to prevent damage to gearcase.

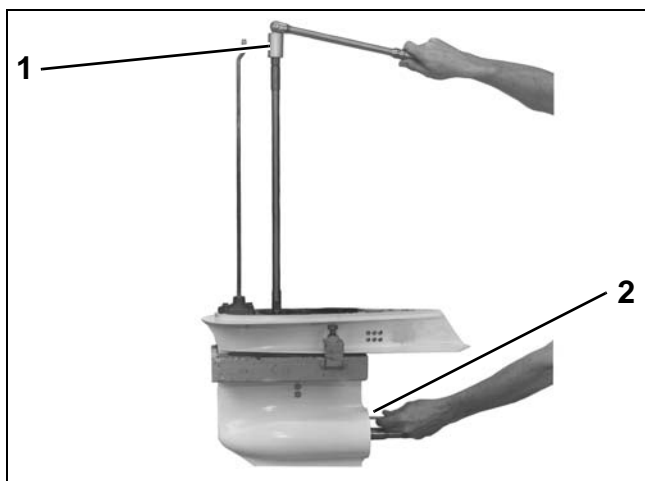

1. Holding socket
  2. 11/16 Wrench
- COA3573T

Remove the four driveshaft bearing housing screws.

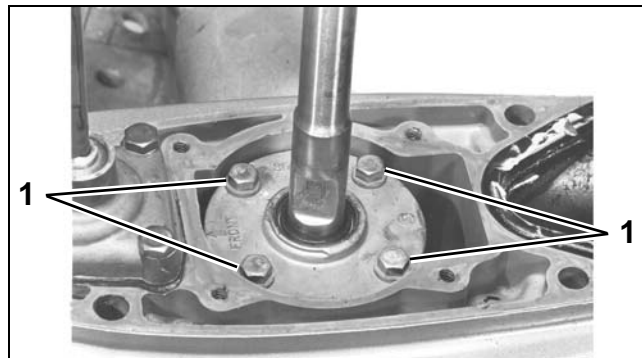

1. Driveshaft bearing housing screws
- COA3671

Remove the driveshaft from the gearcase. The bearing housing, shims, thrust bearing, and thrust washer will come out with the driveshaft.

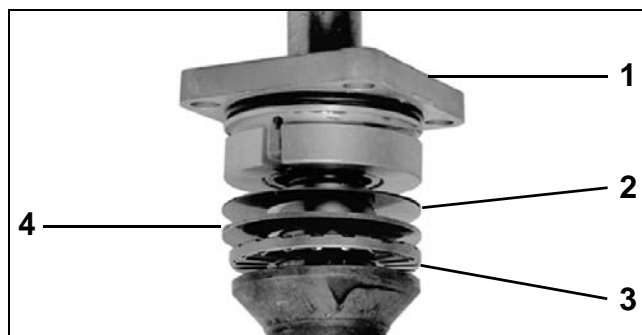

1. Bearing housing
  2. Shims
  3. Thrust bearing
  4. Thrust washer
- COA3558

If driveshaft cannot be removed, refer to **Locked Driveshaft Removal on p. 304.**

Remove the pinion gear from the gearcase.



COA3159

## GEARCASE SERVICE, 40 – 65 HP MODELS

### GEARCASE DISASSEMBLY

#### Locked Driveshaft Removal

The driveshaft to pinion taper is a locking taper. If necessary, use Puller, P/N 387206, and Backing Plate, P/N 325867, to break the lock. Install the tools as shown by clamping them around the driveshaft with the tool's setscrew aligned with the impeller drive key slot. Tighten the setscrew into the slot. Alternately tighten the two vertical screws against the backing plate inserted between the puller and the gearcase until the driveshaft pops loose from the pinion.

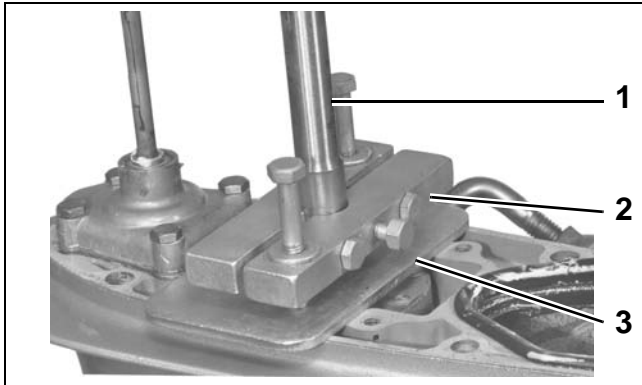

1. Drive shaft
2. Puller
3. Backing plate

COA3664

#### Shift Housing, Gear and Propeller Shaft Removal

Push down on the shift rod. This will move the detent lever downward to clear the inside of the gearcase when the shaft assembly is pulled out. Unscrew the shift rod from the detent lever. Remove screws, cover, and shift rod from the gearcase.

Discard the cover gasket. Remove and discard the shift rod O-ring from inside of cover.

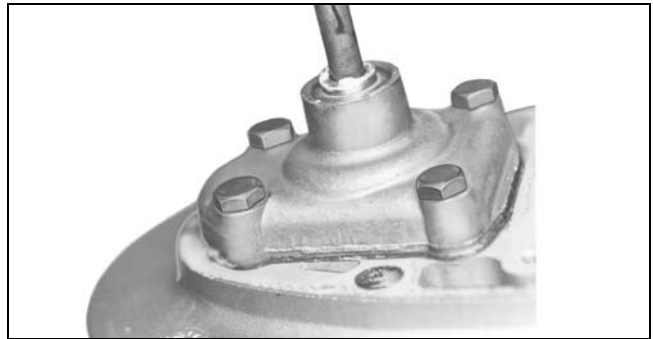

COA3666

**IMPORTANT:** Make sure oil fill/drain plug is removed from gearcase.

Remove propeller shaft assembly from gearcase.

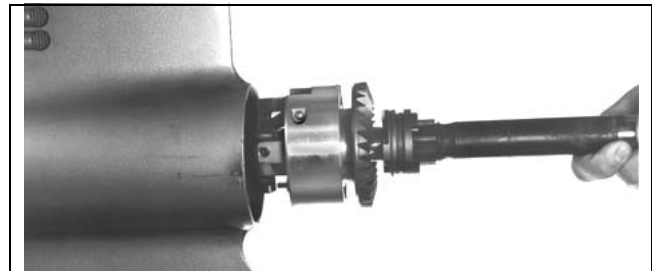

COA3575

# SHIFTER, BEARING AND SEAL SERVICE

## Pinion Bearing Removal

Inspect the pinion bearing for damage without removing it. If the bearing is removed for any reason, it must be replaced.

If the pinion bearing must be replaced, remove the bearing retaining screw from the gearcase. Discard the O-ring from the screw.

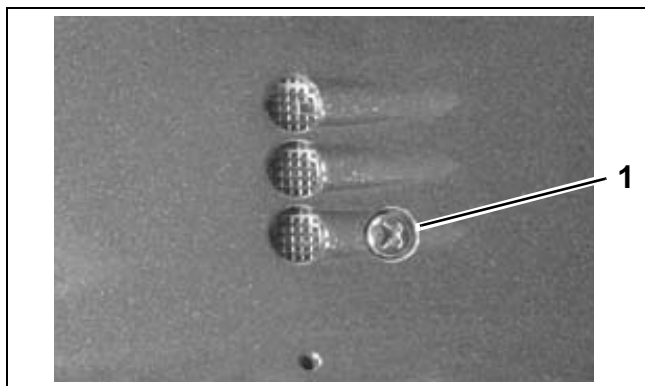

1. Bearing retaining screw

001997

Assemble Pinion Bearing Remover and Installer, P/N 5005927, in the gearcase as follows:

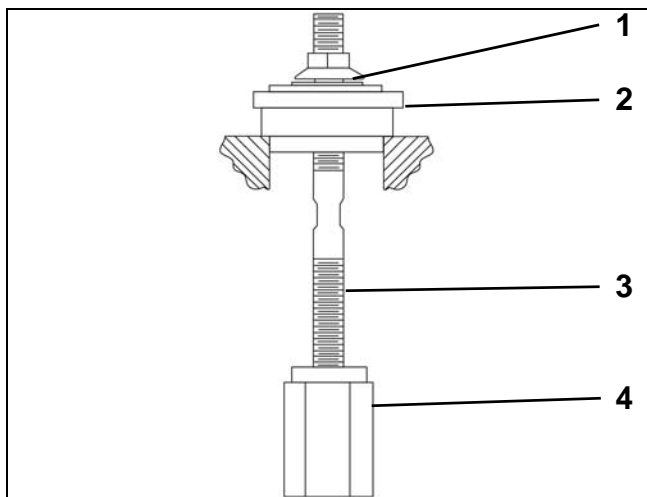

1. Flange Nut, P/N 326586
2. Plate, P/N 391260
3. Rod, P/N 326582
4. Remover, P/N 326580

813305

Use a 1 in. wrench to hold the remover in place. Use a 3/4 in. wrench to turn flange nut clockwise and draw the bearing up from the housing.

## Water Intake Screen

Inspect the water intake screen for blockage and remove it by depressing the tabs on either side of the screen and pushing upward.

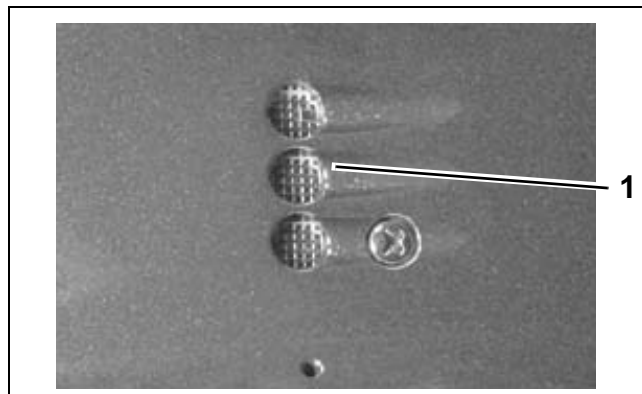

1. Water intake screen

001997

## Pinion Bearing Installation

Install the water intake screen. Drop it into the water intake cavity and use a suitable tool to push it down as far as it will go.

Assemble Pinion Bearing Remover and Installer, P/N 5005927, as shown:

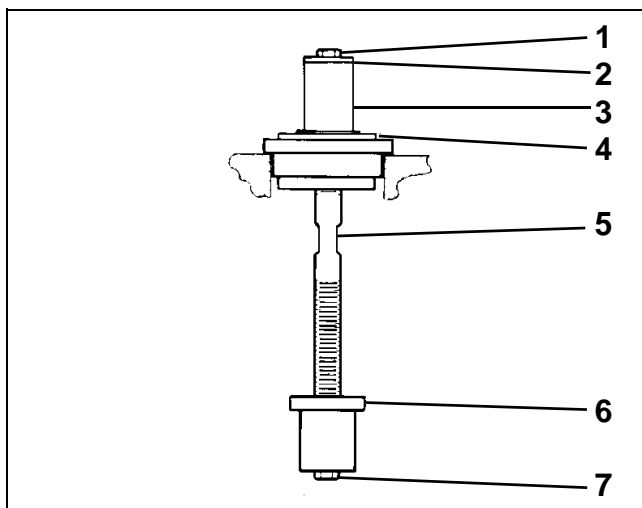

1. 1/4-20 X 1/2 in. Hex head screw
2. 1 in. O.D. Flat washer
3. Spacer, P/N 326584
4. Plate, P/N 391260
5. Rod, P/N 326582
6. Installer, P/N 326575
7. 1/4-20 X 1 1/4 in. Hex head screw

824182

**IMPORTANT:** Spacers are different sizes and cannot be interchanged.

## GEARCASE SERVICE, 40 – 65 HP MODELS SHIFTER, BEARING AND SEAL SERVICE

Place the bearing on the installer tool with the **lettered side of the bearing facing the top** of the gearcase. Use *Needle Bearing* grease to hold the bearing on the tool.

Insert the tool with the bearing into the gearcase. Drive the bearing into the gearcase until the washer on the tool contacts the spacer.

Place a new O-ring on the pinion bearing retaining screw. Apply *Gasket Sealing Compound* to O-ring and *Nut Lock* to screw threads. Install the screw and tighten to a torque of 48 to 80 in. lbs. (5.5 to 9.0 N-m).

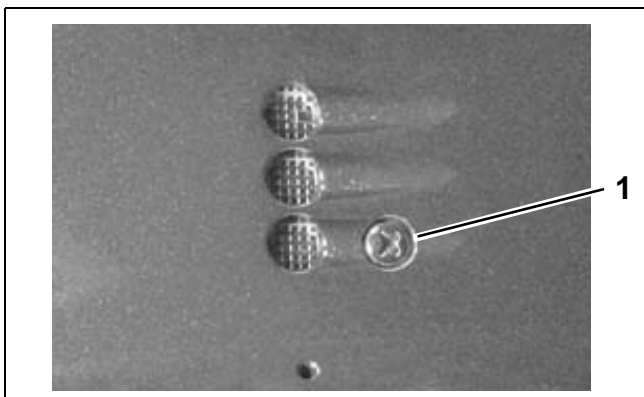

1. Bearing retaining screw

001997

### Shift Housing Disassembly

#### **WARNING**

**Wear safety glasses to avoid injury.**

**IMPORTANT:** The shift housing and forward gear bearing are serviced as an assembly. If either are worn or damaged, replace the complete assembly.

Insert a suitable tool under one end of the clutch dog spring and remove it from its groove by

unwrapping it from around the clutch dog. **Discard the spring.**

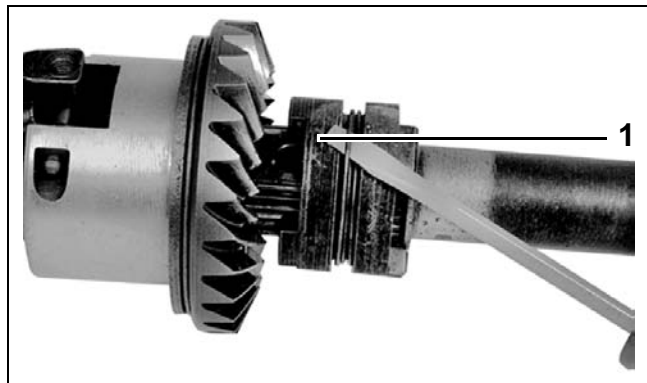

1. Clutch dog spring

COA3560

Push the pin out of the clutch dog. Remove all parts.

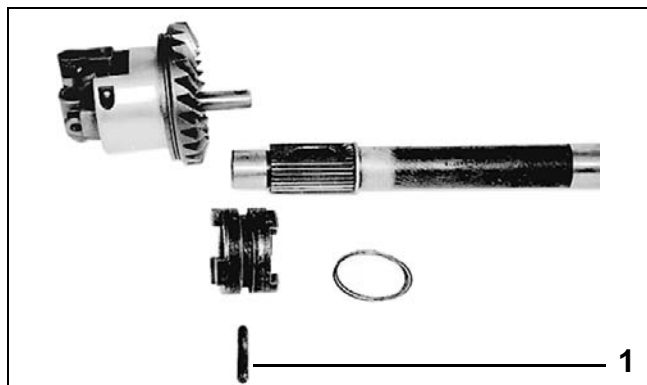

1. Pin

COA3561

Remove the gear, thrust bearing, and thrust washer from the shift housing.

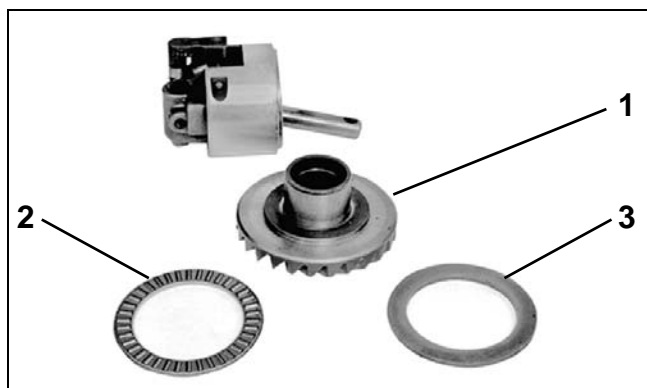

1. Gear  
2. Thrust bearing  
3. Thrust washer

COA3562

Remove the shift lever pin from the housing. Remove shift shaft, cradle and shift lever. Move shifter detent as needed to help ease removal of parts.

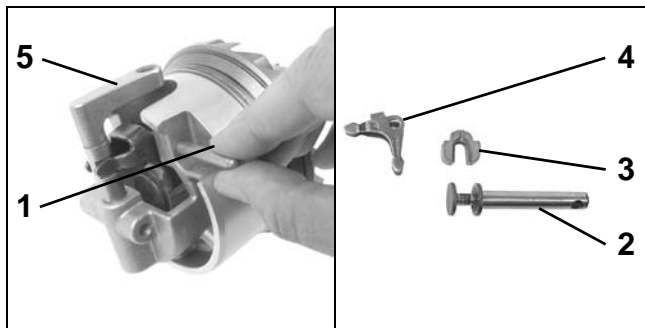

1. Shift lever pin
2. Shift shaft
3. Cradle
4. Shift lever
5. Shifter detent

DSC02449  
 DSC02489

**⚠ WARNING**

**Wear safety glasses to avoid personal injury. The detent ball and spring and come out with great force.**

Wrap the housing with a shop cloth to catch ball and spring. Rotate the shifter detent 90° in either direction, then pull the detent out of the housing.

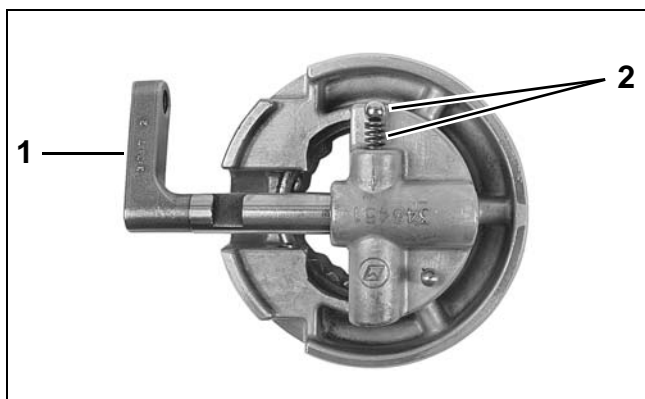

1. Shifter detent
2. Ball and spring

DSC02518

Remove the detent ball and spring.

## Shift Housing Assembly

**IMPORTANT:** Clean and inspect all parts before beginning assembly procedures. Replace any damaged parts.

Lightly coat the detent ball and spring with *Needle Bearing* grease. Insert the spring in the housing, then the ball.

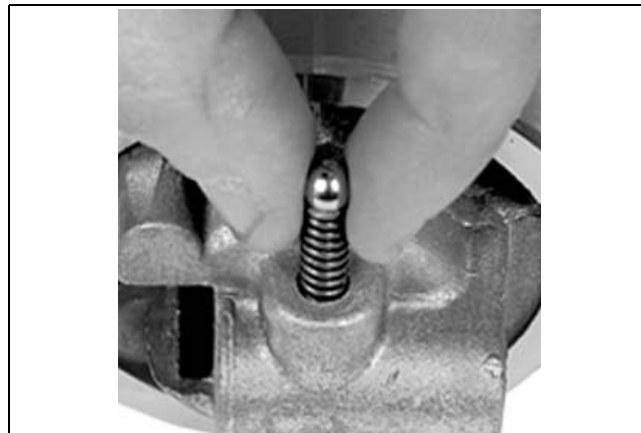

4518

Insert shifter detent at 90° angle into the housing as shown, while depressing the ball and spring with a suitable tool. Once the shifter detent is past the ball, remove the tool and position detent to engage NEUTRAL position.

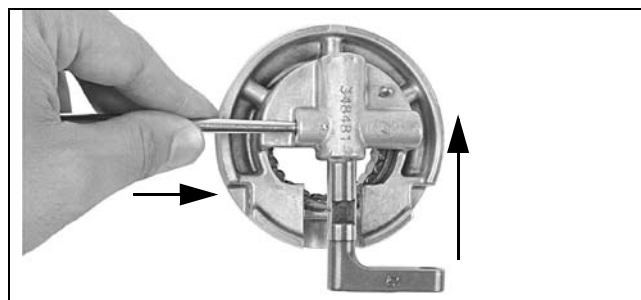

DSC02506

## GEARCASE SERVICE, 40 – 65 HP MODELS

### SHIFTER, BEARING AND SEAL SERVICE

With shifter detent in NEUTRAL, install arms of shift lever into detent slots. Align the pivot holes and insert the retaining pin. Push shifter detent down.

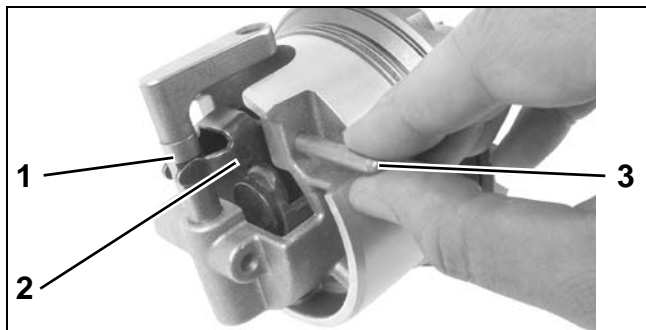

1. Shifter detent
2. Shift lever
3. Pin, shift lever

DSC02449

Rest the cradle on the shift shaft.

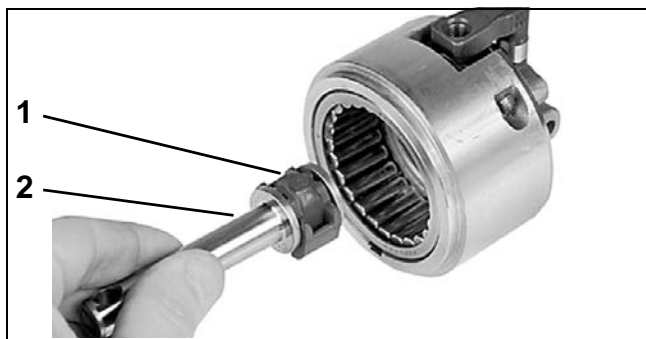

1. Cradle
2. Shift shaft

4512

Place the shift lever arms into the recesses of the shift cradle. Pull shifter detent back up to NEUTRAL position to hold the cradle and shaft in position.



001219

Coat thrust bearing and thrust washer with *Needle Bearing* grease. Place the bearing on the back of the gear. Set the washer on top of the thrust bearing. Insert the gear, bearing, and washer into the bearing housing.

**NOTICE** Bearing and washer must be installed in the correct order.

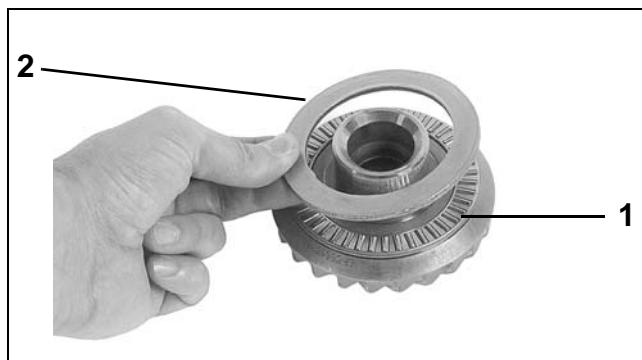

1. Thrust bearing
2. Thrust washer

DSC02297

Align holes in the clutch dog with slot in the propeller shaft. Install the clutch dog with grooved end toward the forward end of the shaft.

**NOTICE** The clutch dog is not symmetrical. If installed backward, it will not fully engage and will immediately damage itself and the gears.

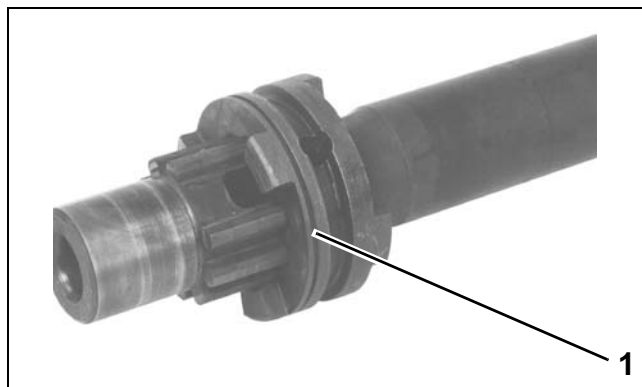

1. Grooved end

COA3591



Slide the propeller shaft onto the shift shaft, align the hole in the shaft with the hole in the clutch dog, install the pin and then, a **new** clutch dog retaining spring. Place three coils over each end of the pin, **MAKING SURE NONE OF THE COILS OVERLAP OR ARE LOOSE.**

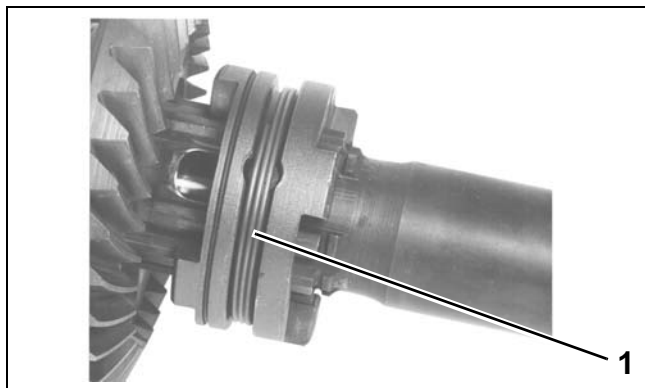

1. Retaining spring

COA3592

## Driveshaft Bearing Housing Service

The driveshaft bearing is not serviceable. Replace the bearing housing assembly if the bearing is worn or damaged. Also, inspect the driveshaft bearing surface if the bearing is damaged.

Remove the driveshaft bearing housing seal using Puller Bridge, P/N 432127, and Large Puller Jaws, P/N 432129. Discard the seal.



14155

Remove and discard the O-ring from the bearing housing.

Clean the bearing housing in solvent to remove sealer from the seal bore and the O-ring groove.

Lightly apply *Gasket Sealing Compound* to a new O-ring. Install the O-ring in top groove of the bearing housing. Do not allow sealant in oil passage.

**NOTICE** Do not install the O-ring in the bearing housing's bottom groove. The bottom groove is an oil passage. Gearcase damage could result.



1. O-ring (top groove)  
 2. Oil passage

14156

Apply *Adhesive 847* to casing of new seal before installing.

Use Seal Installer, P/N 342665 to install seal in bearing housing with the exposed lip facing away from housing. Apply *Triple-Guard* grease to seal lips.

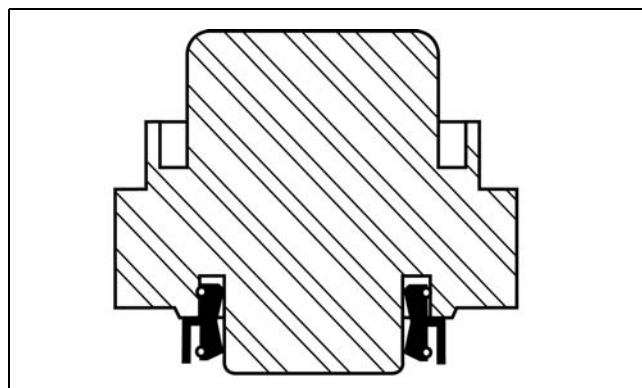

DRC5720

## Propeller Shaft Bearing Housing Service

### Rear Seal Removal

Remove seals using Puller Bridge, P/N 432127, and Large Puller Jaws, P/N 432129. Place the plate on top of the housing to support the bridge, and tighten jaws securely behind the inner seal.



21047

### Bearing Removal

**IMPORTANT:** Inspect bearings in place. If a bearing is removed for any reason, it must be discarded.

Remove rear bearing using Puller Bridge, P/N 432127, and Large Puller Jaws, P/N 432129. Place the puller plate on top of the housing to support the bridge, and tighten jaws securely behind the bearing.



21045

Remove front bearing using Puller Bridge, P/N 432127, and Bearing Puller, P/N 432130. Place the puller plate on top of the housing to sup-

port the bridge, and tighten jaws securely behind the bearing.



21067

Inspect the bearing housing anode. Replace anode if it is reduced to two-thirds of original size. Tighten screws to a torque of 108 to 132 in. lbs. (12 to 15 N·m).



1. Anode

001220

Discard the bearing housing O-ring. Clean the housing and bearings in solvent and dry thoroughly. If bearings were not replaced, rotate the needles to check for freedom of movement.

Inspect O-ring groove. Sand off any sharp edges that might cut O-ring. Remove any nicks or burrs on front of bearing housing.



1. O-ring groove

DSC02291

Thoroughly clean the four bearing housing retaining screws in solvent. Discard the O-rings.

### Bearing Installation

Oil, then install new bearings in bearing housing.

Place the **lettered end** of the bearing case on the bearing installer, then press the bearing into the housing until the tool seats. When installed, the lettered end of the bearing should be visible.

Bearing Installation Tool:

- P/N 326562

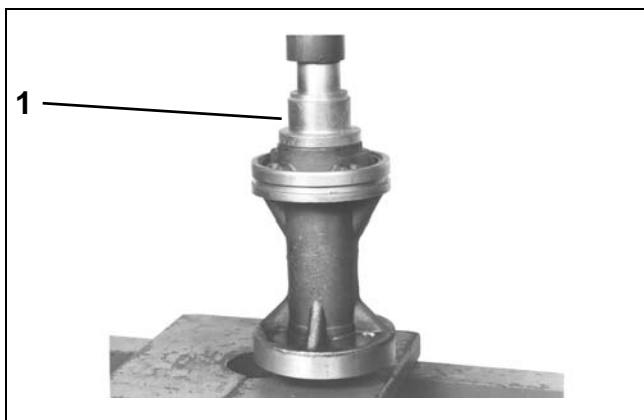

**Forward Bearing**  
1. Bearing installation tool

COA3579

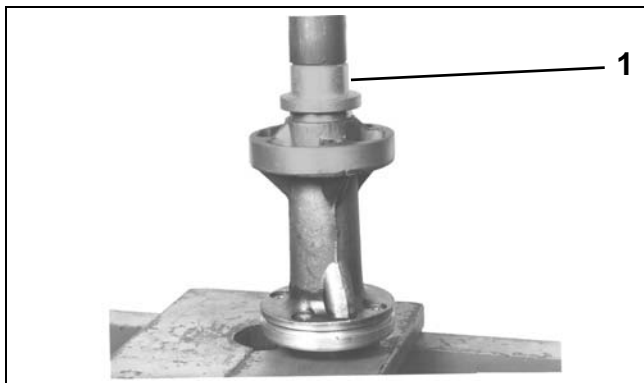

**Rear Bearing**  
1. Bearing installation tool

COA3580

### Rear Seal Installation

Apply *Gasket Sealing Compound* to metal casings of the seals before installing.

Use Seal Installation Tool to install new seals back to back in bearing housing.

Seal Installation Tool:

- P/N 326551

Install inner seal with lip facing toward the bearing housing, then outer seal with lip facing away from the bearing housing.

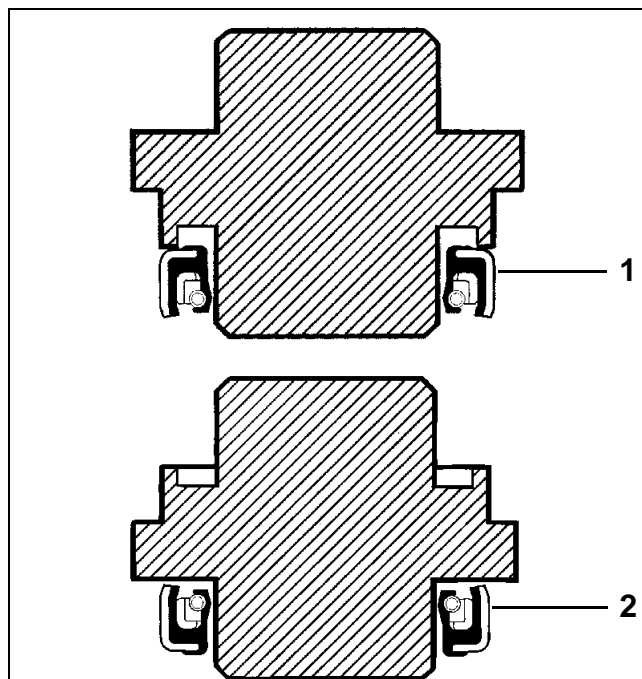

1. Inner seal
2. Outer seal

DR2061  
DR2062

Apply *Triple-Guard* grease to seal lips.

## DRIVESHAFT SHIMMING

**NOTICE** If a new pinion gear is needed, replace gear set before shimming.

Pinion gear backlash is adjusted by using shims between the driveshaft bearing housing and the thrust washer. When installing a new thrust bearing or washer, bearing housing, pinion, or driveshaft, it is necessary to properly shim the assembly to restore the correct clearance.

Use Driveshaft Shimming Tool, P/N 5005925.

Shim gauge bars are precision made and should be handled carefully. The length of each bar is stamped near the part number. This dimension is 0.020 in. (0.508 mm) shorter than the actual shimmed length of the driveshaft.

**IMPORTANT:** Clean pinion and driveshaft before assembly. Replace any damaged parts.

Assemble the driveshaft bearing housing, thrust washer, thrust bearing, and pinion onto the driveshaft. Use Driveshaft Seal Protector, P/N 312403, when installing or removing the bearing housing.

Lightly coat the threads of the pinion nut with out-board lubricant and tighten to a torque of 40 to 45 ft. lbs. (54 to 60 N·m).

**IMPORTANT:** The original pinion nut may be used for shimming, but must **NOT** be used in final assembly.

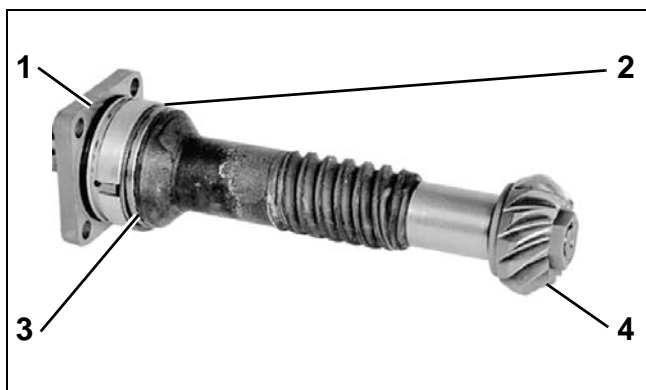

1. Driveshaft bearing housing COA3565  
 2. Thrust washer  
 3. Thrust bearing  
 4. Pinion

Select correct collar and shim gauge bar:

- Collar: P/N 328363
- Shim gauge bar: P/N 328366

Slide the collar onto the driveshaft with large end in contact with the bearing housing.

Insert the assembled driveshaft into the tool base and tighten preload screw against the driveshaft until groove on the spring-loaded plunger is flush with end of threads. Tighten locking ring on preload screw.

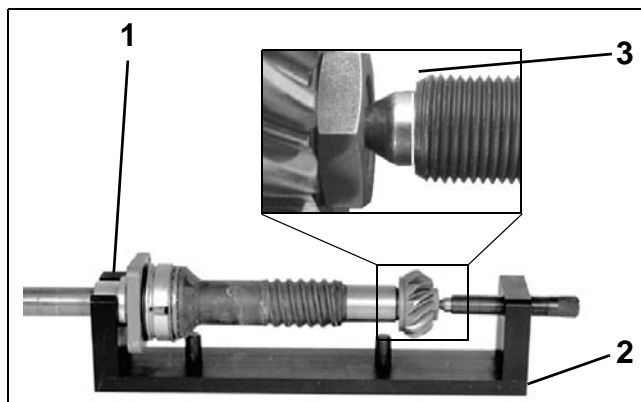

1. Collar COA3566  
 2. Tool base DSC00326  
 3. Groove

Rotate the driveshaft several revolutions to seat bearings.

Lay the tool base on its side. Place the shim gauge bar against guide pins of the tool base.

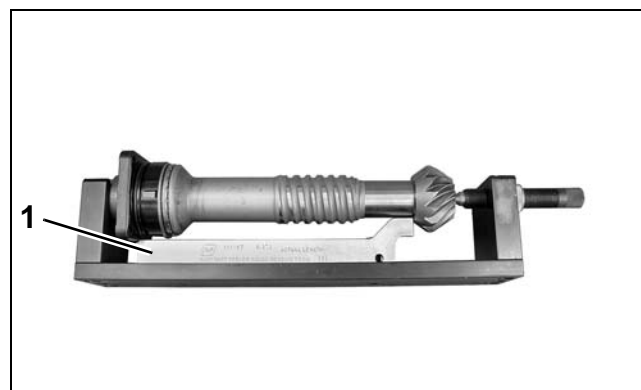

1. Shim gauge bar 005416

Check squareness of the bearing housing mounting surface by holding the shim gauge bar against the pinion while rotating **just the bearing housing**. Use a feeler gauge to measure clearance

between the gauge bar and the bearing housing between each pair of screw holes. Replace the bearing housing and repeat check if variance is greater than 0.004 in. (0.101 mm).

Check squareness of the pinion to the driveshaft. Hold the shim gauge bar against the bearing housing (between the screw holes) while rotating **just the driveshaft and pinion assembly**. Measure clearance between the gauge bar and the pinion at several locations. If variance is greater than 0.002 in. (0.050 mm) replace the pinion or driveshaft, as necessary, and repeat check.

Subtract the average clearance measurement from 0.020 in. (0.508 mm) to determine the correct shim thickness required. Select the fewest number of shims to achieve the correct thickness.

Remove the driveshaft from the tool and add the required shims between the bearing housing and the thrust washer.

**IMPORTANT:** Use extreme care when removing bearing housing to avoid damaging the seals. Use Driveshaft Seal Protector, P/N 312403.

Check clearance again. The measurement between the gauge bar and pinion should be 0.020 in. (0.508 mm).

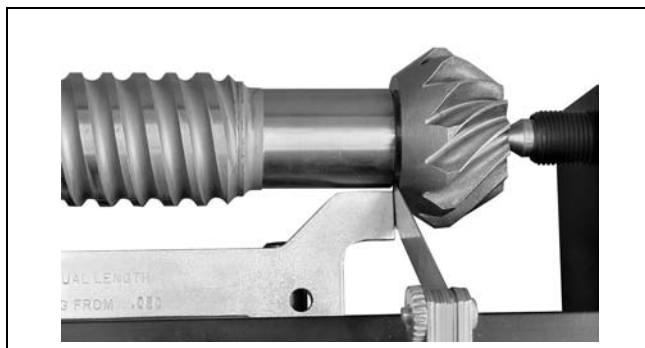

005417

Remove the nut and pinion from the driveshaft. Discard the nut.

## GEARCASE ASSEMBLY

### Shift Housing, Gear, and Propeller Shaft Installation

Push shifter detent into farthest downward position. Tip the rear of the gearcase slightly downward to assist in the installation of the shaft assembly.

Be sure the thrust bearing and the thrust washer are in the proper position. Insert the shaft assembly fully into the gearcase while aligning shift housing pin with hole in forward end of gearcase housing.

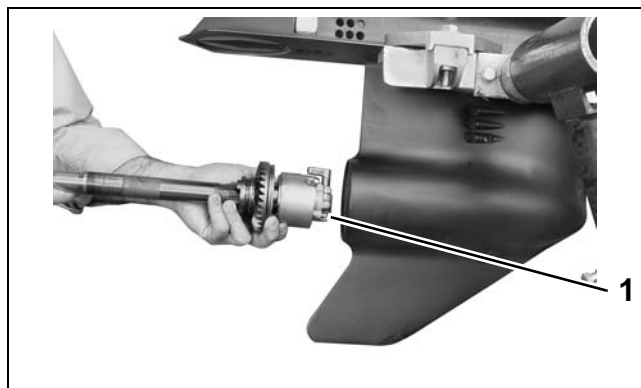

1. Pin

006648

### Shift Rod Housing Installation

Lubricate a new shift rod cover O-ring with *Triple-Guard* grease. Install the O-ring into the shift rod cover.

**IMPORTANT:** Make sure O-ring is fully seated in groove.

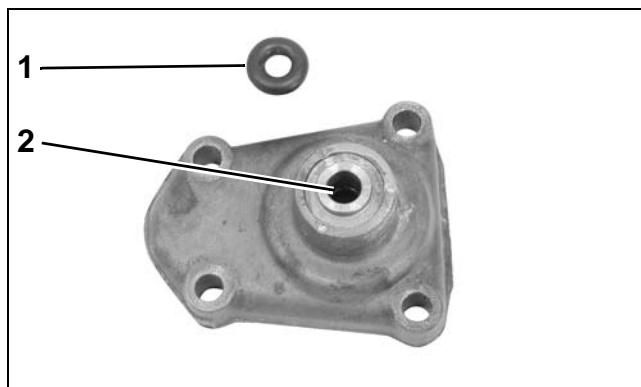

1. O-ring  
2. Groove

006649

## GEARCASE SERVICE, 40 – 65 HP MODELS

### GEARCASE ASSEMBLY

Apply *Triple-Guard* grease to the threaded end of the shift rod and insert it through the cover. Turn the shift rod while pushing it through the cover to avoid damaging the O-ring.

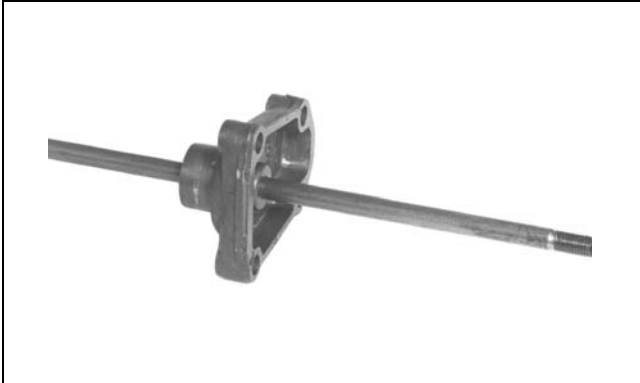

COA3544

Apply *Gasket Sealing Compound* to both sides of a new shift rod cover gasket. Place the gasket on the gearcase. Thread the shift rod into the shifter detent about four turns.

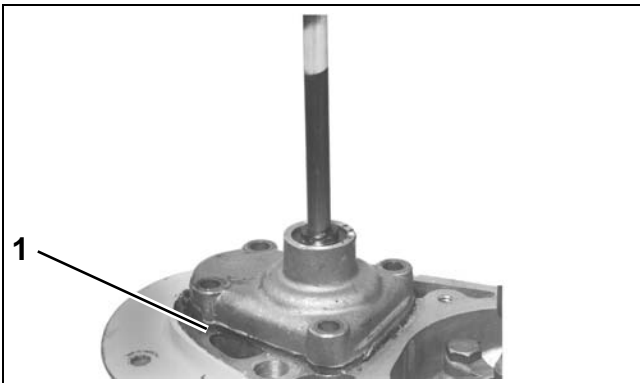

1. Cover gasket

COA3545

Move shift rod from side to side while pushing on the propeller shaft to ensure proper alignment of the bearing housing locator pin into the pin hole in the gearcase.

Apply *Gasket Sealing Compound* to the threads of the shift rod cover screws. Tighten the screws to a torque of 60 to 84 in. lbs. (7 to 9.5 N·m).

Place the cover seal on the shift rod cover.

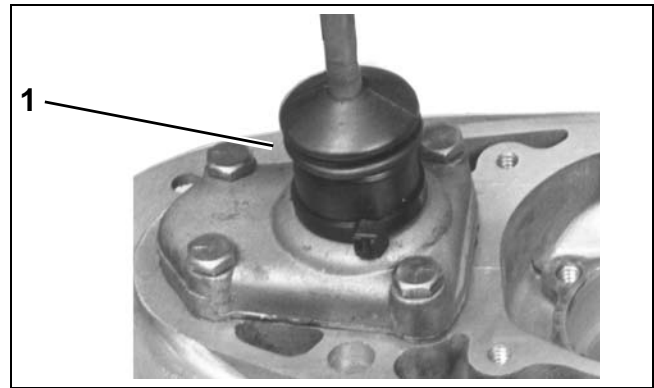

1. Cover seal

002514

## Pinion Gear and Driveshaft Installation

Refer to **DRIVESHAFT SHIMMING** on p. 312 before proceeding.

Install new seals in driveshaft bearing housing. Refer to **Driveshaft Bearing Housing Service** on p. 309.

Place the driveshaft thrust bearing, thrust washer, and correct shim(s) on the driveshaft as shown.

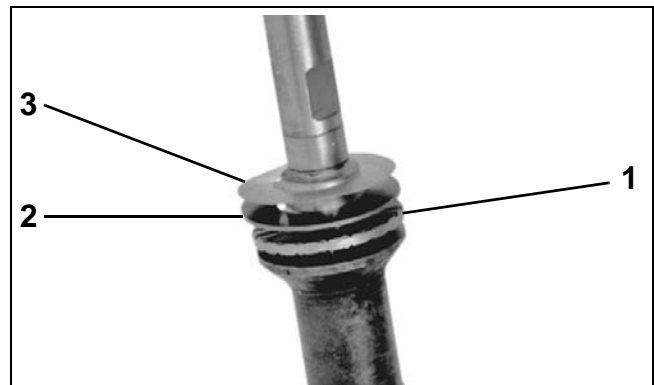

1. Thrust bearing  
2. Thrust washer  
3. Shim(s)

COA3168

Lightly apply *Gasket Sealing Compound* to the gearcase area that contacts mounting flange of

## GEARCASE SERVICE, 40 – 65 HP MODELS GEARCASE ASSEMBLY

the driveshaft bearing housing. Do not coat inside bearing housing bore surface of the gearcase.

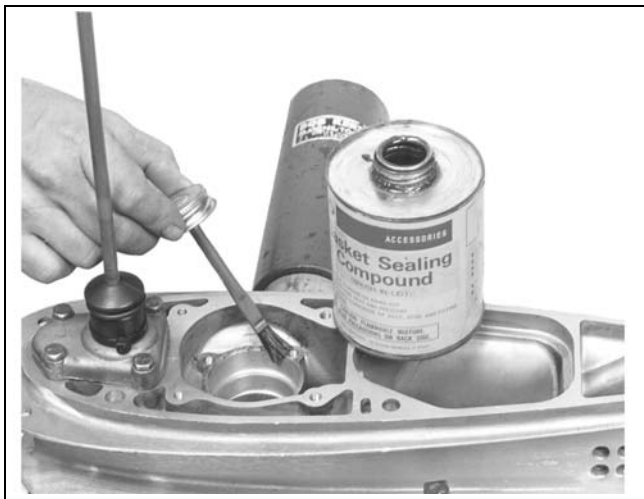

6207

Adjust shift rod to move clutch dog as far forward as possible. Be sure excess grease is removed from the pinion bearing.

**IMPORTANT:** The inside taper of the pinion gear and the driveshaft taper **MUST** be completely free of grease. Clean the tapers with *Cleaning Solvent*. Use a shop towel free of grease and lint.

Place the pinion gear into the gearcase. Insert the driveshaft into the gearcase and through the pinion gear.

Using Driveshaft Seal Protector, P/N 312403, slide the driveshaft bearing housing onto the driveshaft and into position in the gearcase. Align the embossed word "FRONT" toward the shift rod. Do not install screws at this time.



1. Seal protector

COA3130

Lightly coat the threads of a **new** pinion nut with outboard lubricant. Use Pinion Nut Starting Tool, P/N 320675, to install nut on the driveshaft. Turn the driveshaft by hand to thread the nut on to shaft.

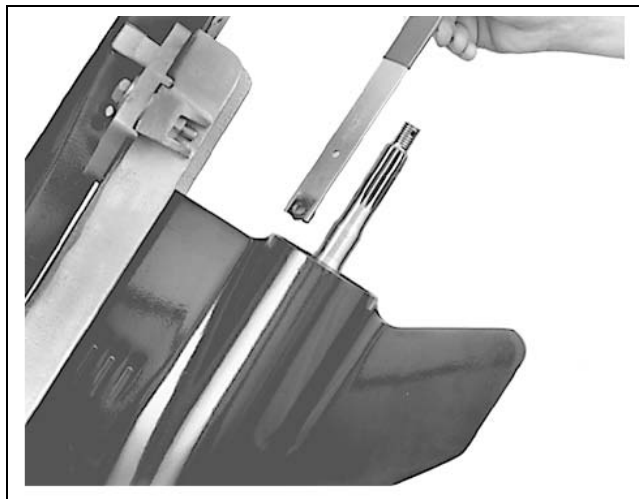

33220

Apply *Gasket Sealing Compound* to the threads of the driveshaft bearing housing screws. Tighten screws **in stages** to a torque of 96 to 120 in. lbs. (11 to 14 N·m).

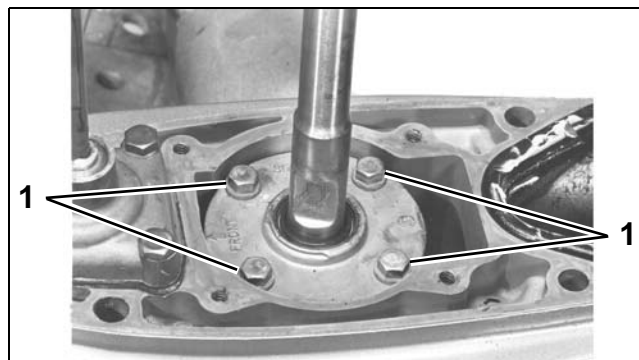

1. Driveshaft bearing housing screws

COA3671

## GEARCASE SERVICE, 40 – 65 HP MODELS

### GEARCASE ASSEMBLY

Use Driveshaft Holding Socket, P/N 334995, and an 11/16 in. open-end wrench, to tighten the pinion nut to a torque of 40 to 45 ft. lbs. (54 to 60s N-m). Pad handle of the wrench to prevent damage to gearcase.

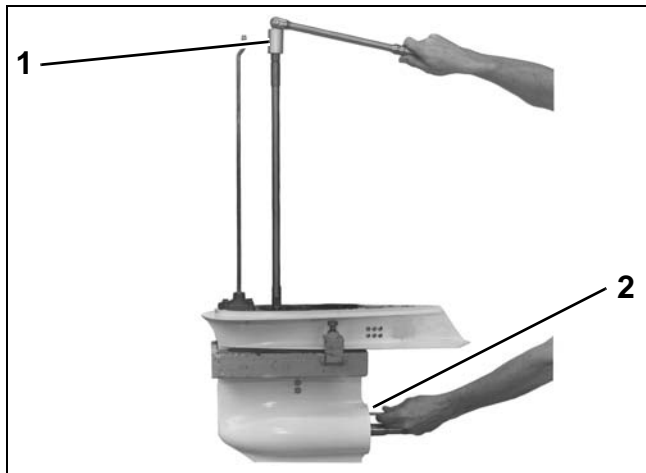

1. Holding socket
2. 11/16 Wrench

COA3573T

### Propeller Shaft Bearing Housing and Gear Installation

Place the small thrust washer in recess of the reverse gear.

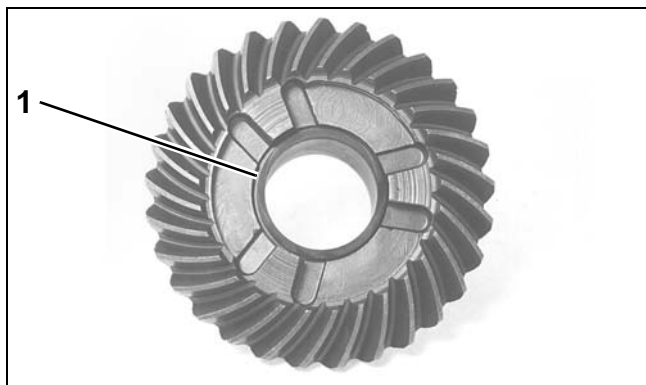

1. Small thrust washer

COA3597

Oil and install thrust bearing and larger thrust washer on hub of reverse gear. Slide the gear

assembly onto the propeller shaft until it engages the pinion gear.

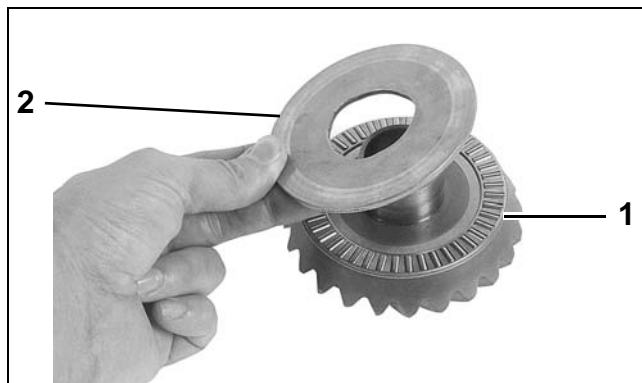

1. Thrust bearing
2. Thrust washer

DSC02295

Slide the bearing housing retainer plate into position over the propeller shaft.



1. Retaining ring

COA3513

Using Retaining Ring Pliers, P/N 331045, install the two retaining rings.

#### **⚠ CAUTION**

Retaining rings are under extreme pressure during installation. Wear safety glasses and proceed with care to avoid unsnapping the ring from the pliers.



Make sure the retaining rings are seated in the grooves in the gearcase.

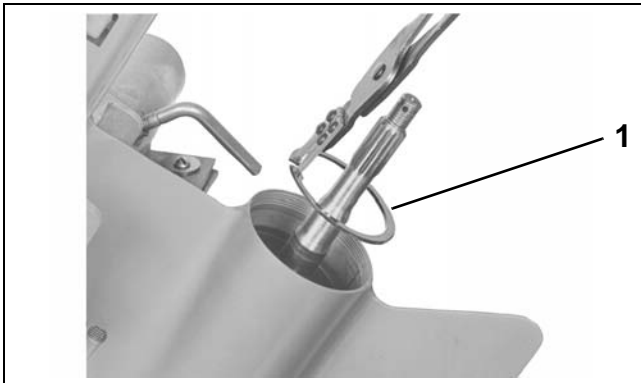

1. Retaining ring

9438

Thread two Guide Pins, P/N 383175, into the retainer plate to align holes in the plate with holes in the propeller shaft bearing housing. Do not thread guide pins more than two turns into the retainer plate.

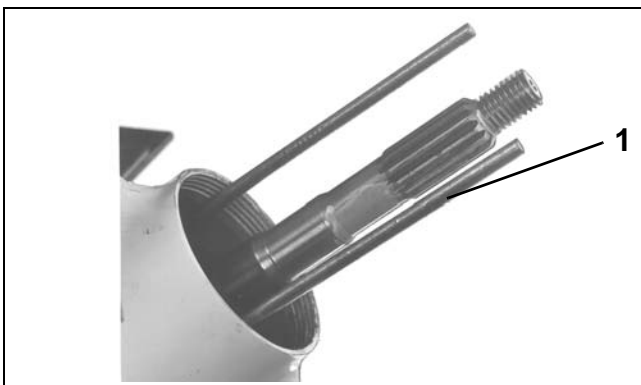

1. Guide pin

COA3550

Install O-ring in groove in the bearing housing. Lightly apply *Gasket Sealing Compound* to the O-ring flange and aft support flange of the bearing housing. Do not allow sealer to contact either forward thrust surface or bearings in the housing.

Align the bearing housing on the guide pins with the word "UP" toward the top. Place the housing into gearcase and tap the housing with a soft face mallet to seat the O-ring.

Apply *Gasket Sealing Compound* to the threads and seals of the four propeller housing retaining screws. Install two of the screws into the bearing housing finger tight. Remove the guide pins and install the remaining two screws. Tighten all four screws to a torque of 120 to 140 in. lbs. (14 to 16 N·m).

## Final Assembly and Adjustment

To complete gearcase assembly, refer to:

- **GEARCASE LEAK TEST** on p. 295
- **WATER PUMP SERVICE** on p. 298
- **SHIFT ROD ADJUSTMENT** on p. 300
- **GEARCASE REMOVAL AND INSTALLATION** on p. 296
- **Gearcase Lubricant** on p. 39
- **Propeller Hardware Installation** on p. 294
- **Trim Tab Adjustment** on p. 31.

During break-in period of a reassembled gearcase, change the gearcase lubricant between 10 to 20 hours of operation.

# GEARCASE REMOVAL AND INSTALLATION

## Gearcase Removal

**⚠ WARNING**

To prevent accidental starting while servicing, twist and remove all spark plug leads.

During service, the outboard may drop unexpectedly. Avoid personal injury; always support the outboard's weight with a suitable hoist or the tilt support bracket during service.

Remove pin and washer from shift rod lever to release the lower shift rod.



1. Shift rod screw

002013

Note where the index mark on the gearcase aligns with the index number of the adjustable trim tab so the trim tab can be installed in the same position. Remove the trim tab retaining screw and trim tab from the gearcase.

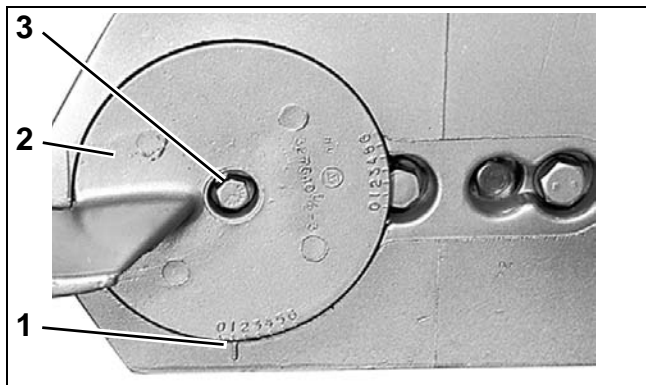

1. Index mark  
 2. Trim tab  
 3. Trim tab retaining screw

COA3663

Remove the 3/8-16 in. screw and washer, and remove 7/16-14 x 3.5 in. screw and washer.

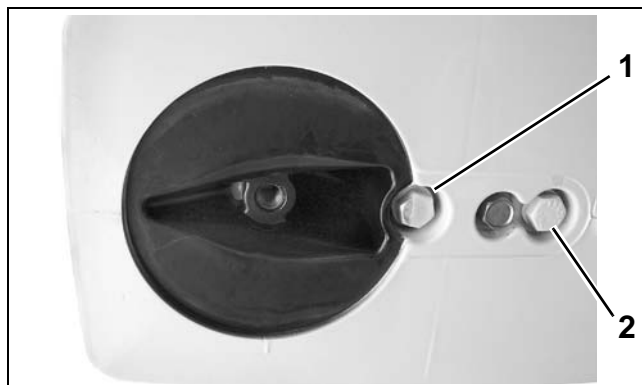

**O Type Gearcases**

1. 3/8-16 x 3.5 in. screw
2. 7/16-14 x 3.5 in. screw

006869

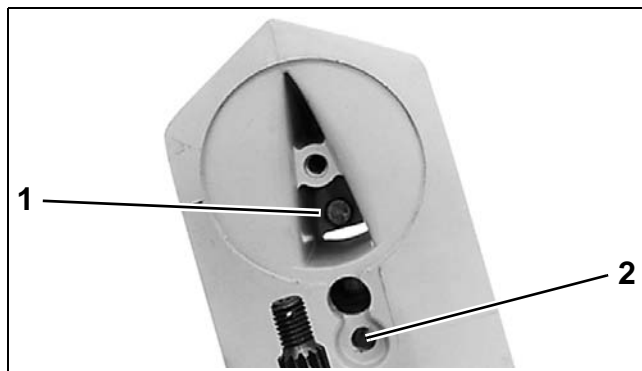

**S Type Gearcases**

1. 3/8-16 x 1.75 in. screw
2. 7/16-14 x 3.5 in. screw

COA3139

Remove the four 3/8-16 x 1.75 in. gearcase retaining screws and washers.

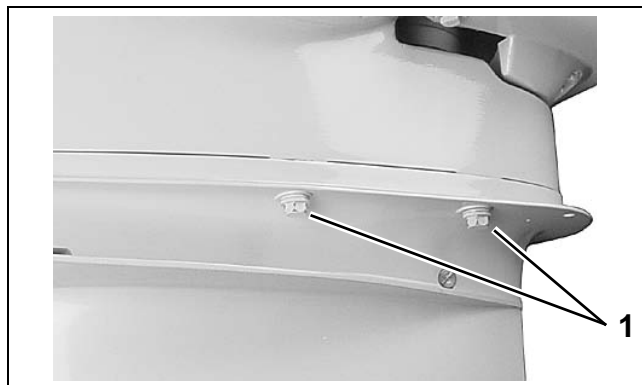

1. Gearcase retaining screws

001990

Remove the gearcase assembly from the exhaust housing, being careful not to bend the shift rod.

## Gearcase Installation

### **⚠ WARNING**

During service, the outboard may drop unexpectedly. Avoid personal injury; always support the outboard's weight with a suitable hoist or the tilt support bracket during service.

**NOTICE** Before installing gearcase, shift rod adjustment **MUST** be checked. Refer to **SHIFT ROD ADJUSTMENT** on p. 323.

Coat the driveshaft splines with *Moly Lube*. DO NOT coat top surface of the driveshaft because lubricant may prevent seating of the driveshaft in the crankshaft.

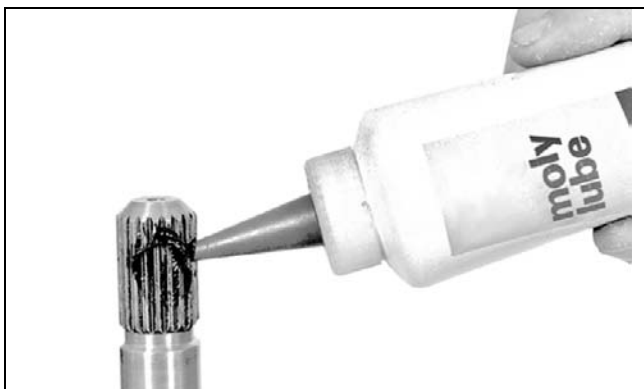

30385

Apply *Adhesive 847* to the lower exhaust housing seals' inner surfaces. Place two new seals on the housing. Apply *Triple-Guard* grease to the seals' outer surfaces and place the housing on the gearcase.

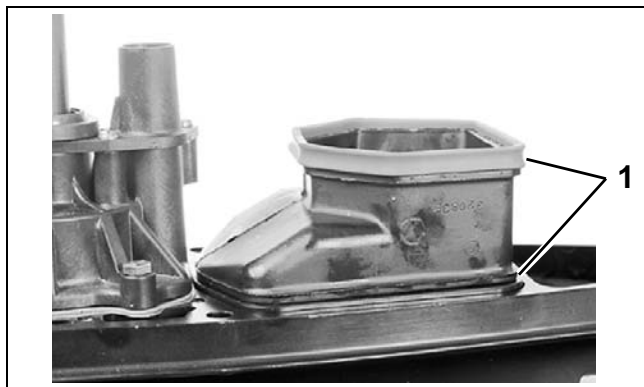

1. Lower exhaust seals

32002

Slide the gearcase into place, making sure:

- Driveshaft engages the crankshaft.
- Water tube enters the water pump.
- Lower inner exhaust housing installs correctly.
- Shift rod does not turn and is positioned properly in the shift rod lever below the crankcase.

**IMPORTANT:** New gearcase screws are treated with a thread-locking material. Apply *Triple-Guard* grease to threads to ensure that the correct clamping force is achieved when tightening—If a previously installed screw is re-used, use a wire brush to remove any old thread-locking material or corrosion and lubricate threads with *Triple-Guard* grease.

Install screws and washers and tighten to a torque of:

- **3/8 in.** screws – 26 to 28 ft. lbs. (35 to 38 N·m)
- **7/16 in.** screws – 45 to 50 ft. lbs. (61 to 68 N·m)

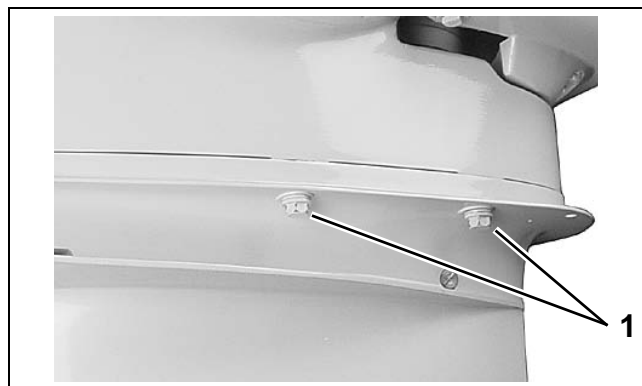

1. 3/8 in. screws

001990

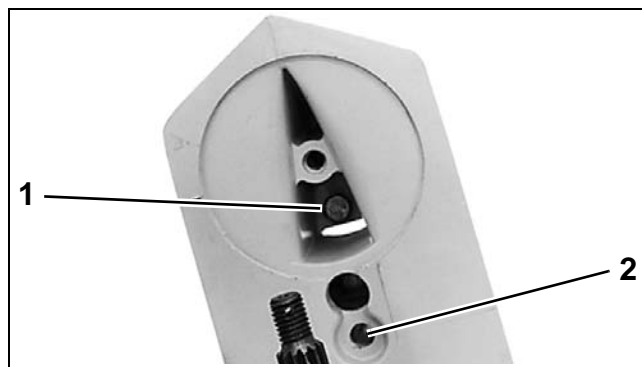

1. 3/8 in screw

2. 7/16 in. screw

COA3139

## GEARCASE SERVICE, 75 – 90 HP MODELS WATER PUMP SERVICE

Apply *Triple-Guard* grease to threads of the trim tab screw. Install and align the trim tab with the index marks noted prior to disassembly. Tighten the trim tab screw to a torque of 35 to 40 ft. lbs. (47 to 54 N-m). For adjustment, refer to **Trim Tab Adjustment** on p. 31.

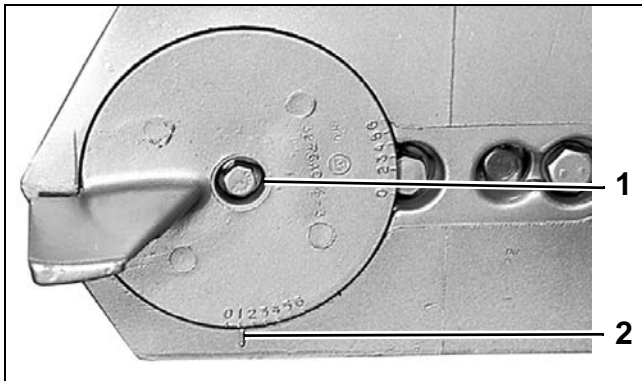

1. Trim tab screw
2. Index mark

COA3663

Place the shift rod in the shift rod lever. Install the retaining pin and washer. Tighten pin to a torque of 60 to 84 in. lbs. (7 to 9.5 N-m).



1. Shift rod screw

002013

### WARNING

To prevent loss of operator control, check for proper shifting operation and adjust, if necessary.

**IMPORTANT:** During break-in period of a reassembled gearcase, change the gearcase lubricant between 10 to 20 hours of operation.

## WATER PUMP SERVICE

### Disassembly

Rotate the driveshaft counterclockwise to unlock the impeller key. Remove the four impeller housing screws.

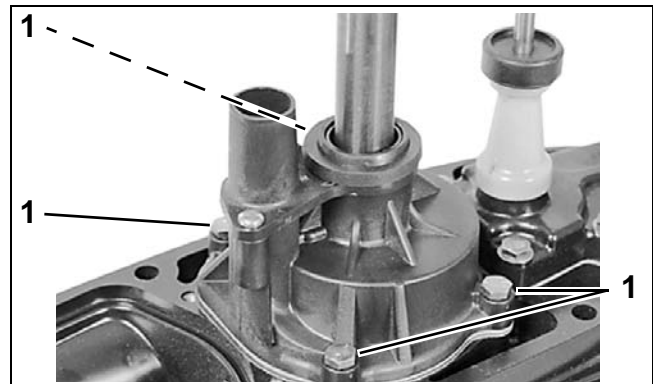

1. Screws

31998

Slide the water pump off the driveshaft. Remove the impeller key, O-ring, impeller plate, and gasket. Discard the gasket.

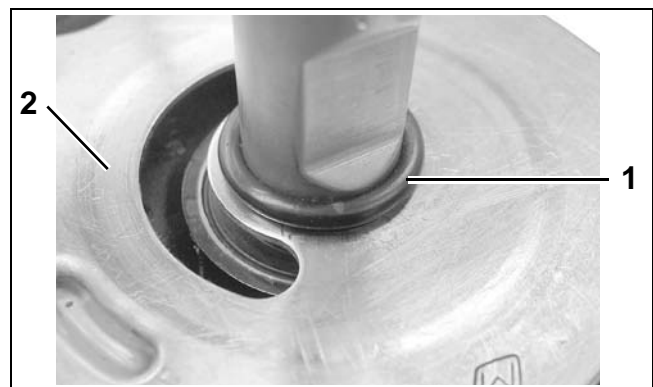

1. O-ring
2. Impeller plate

DSC02328

Remove all the parts from the housing.

### Inspection

Check impeller for overheating, hub separation, and other wear or damage.

Check liner and wear plate for scoring, distortion, and impeller material transfer.

Inspect the housing for cracks or melting.

Make sure gasket surface is clean and smooth.

## Assembly

Apply a drop of *Adhesive 847* in the seal ring groove at each of the four ribs.

**IMPORTANT:** Do not allow any sealer to get into the air bleed groove in the impeller housing. If this groove is blocked by adhesive, the pump will lose its prime and will not pump water.

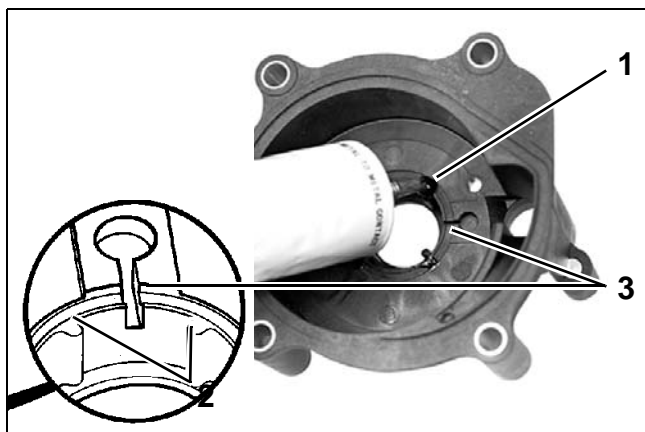

1. Seal ring groove
2. Ribs
3. Air bleed groove

2311  
DR1185

Install the O-ring in groove in the impeller housing.

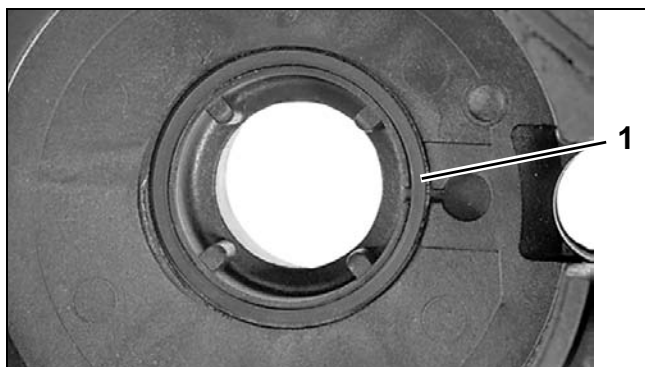

1. O-ring

34814

Lightly coat the exterior rim of the impeller cup with *Gasket Sealing Compound*. Install the cup in the impeller housing. The cup locks in place in the housing with a square index tab.

Make sure vent hole in impeller cup is open.

Install the water tube grommet with the inside taper facing up.

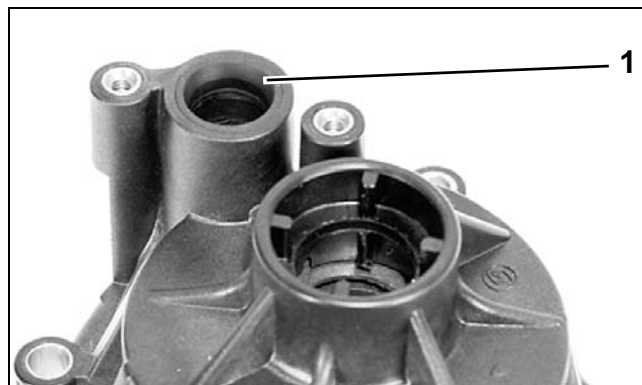

1. Water tube grommet

32000

Apply *Triple-Guard* grease to screw threads and install the impeller housing cover and tighten screws to a torque of 24 to 36 in. lbs. (3 to 4 N·m).

Apply *Adhesive 847* to flat side of the impeller housing grommet. Install the grommet, flat side down.

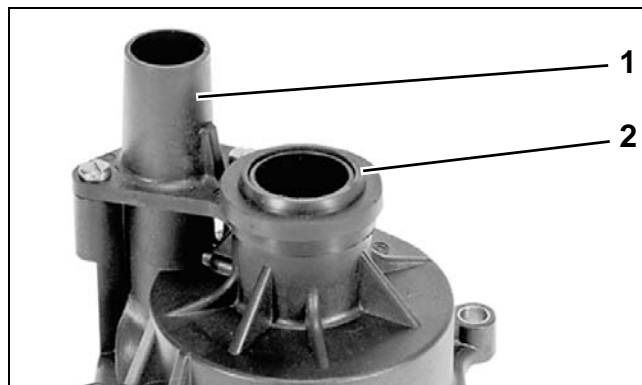

1. Impeller housing cover
2. Impeller housing grommet

32001

Lightly coat the inside of the liner with *Triple-Guard* grease. With a counterclockwise rotation, install the impeller into the liner with the slot for the impeller key facing out.

## GEARCASE SERVICE, 75 – 90 HP MODELS

### WATER PUMP SERVICE

Apply a thin bead of *Adhesive 847* in the seal groove, and install the special shaped O-ring seal.

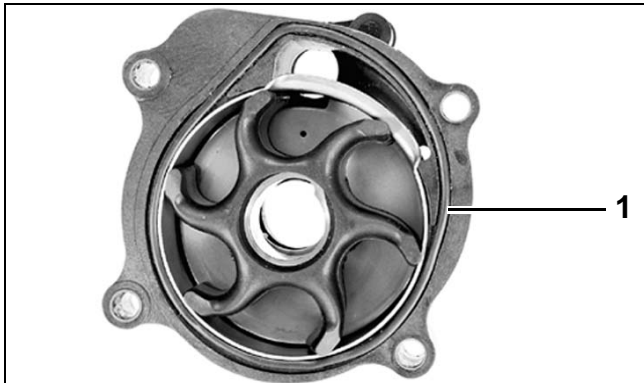

1. O-ring

34815

Apply *Gasket Sealing Compound* to both sides of a new impeller plate gasket. Install the gasket and impeller plate.

Apply *Triple-Guard* grease to a new impeller O-ring. Slide the O-ring down the driveshaft and half way over installed impeller key to temporarily hold key in place.

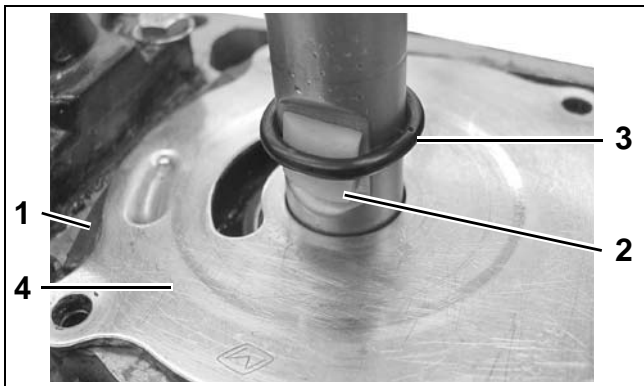

1. Impeller plate gasket  
2. Impeller plate  
3. O-ring  
4. Drive key

DSC02326

The sharp edge of the key is the leading edge in clockwise rotation.

Slide the water pump down the driveshaft. Align impeller slot with the impeller key. Rotate the driveshaft to engage the key with the impeller, and

slide water pump down over key. Be sure impeller key does not fall out of position.

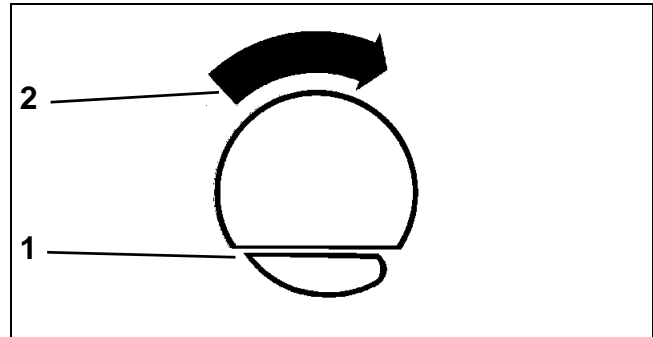

1. Sharp edge of drive key  
2. Direction of driveshaft rotation

CO2995

**NOTICE** Make sure the impeller engages the impeller key. Serious powerhead damage will result if impeller key is not in place.

Align the impeller housing with the gearcase. Apply *Gasket Sealing Compound* to threads of the four impeller housing screws. Install the screws and tighten to a torque of 60 to 84 in. lbs. (7 to 9.5 N·m).

On 25 in. models, place water tube spacer and grommet on the impeller housing cover.

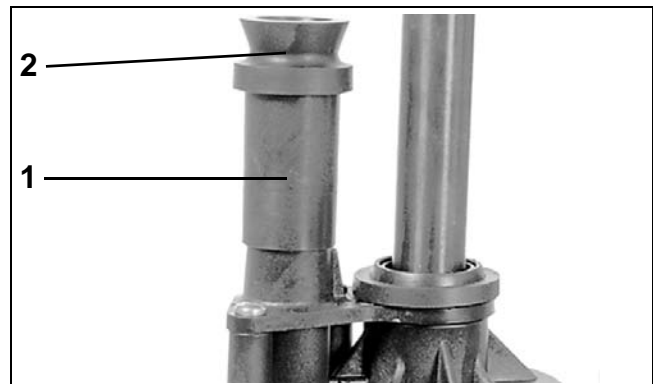

25 in. Model Water Tube Spacer

1. Spacer  
2. Grommet

32728

**NOTICE** Before installing gearcase, shift rod adjustment **MUST** be checked. Refer to **SHIFT ROD ADJUSTMENT** on p. 323.

## **SHIFT ROD ADJUSTMENT**

Check the shift rod height from the shift rod hole to the surface of the gearcase using Universal Shift Rod Height Gauge, P/N 389997.

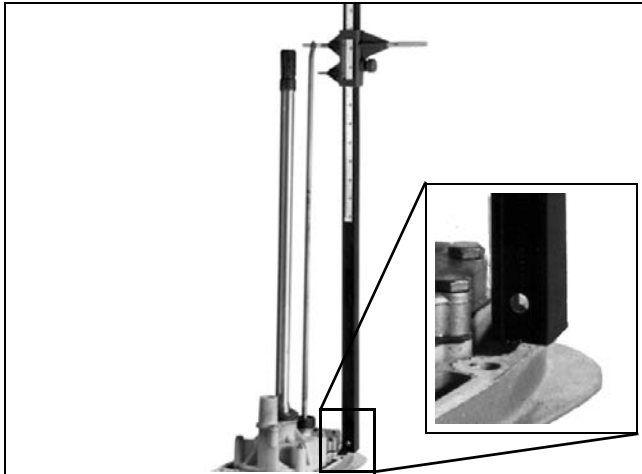

COA6166

With the gearcase in NEUTRAL, rotate the shift rod up or down as necessary for correct adjustment. Once correct height is achieved, rotate rod one half turn or less to direct offset forward.

**IMPORTANT:** The NEUTRAL detent is a two-step design. Make sure the NEUTRAL detent ball is in the center step before checking shift rod height.

### **Shift Rod Heights**

<b>Model</b>	<b>Type</b>	<b>Height</b>
20 in. (L)	"S"	21.25 in. ± One-Half Turn
25 in. (X)	"O"	26.25 in. ± One-Half Turn

# GEARCASE DISASSEMBLY

## Pre-Disassembly Inspection

**⚠ WARNING**

Wear safety glasses to avoid personal injury, and set compressed air pressure to less than 25 psi (172 kPa).

**IMPORTANT:** Clean and inspect all parts during disassembly. Replace any damaged parts, seals, O-rings, and gaskets.

Remove the propeller and mounting hardware.

Drain and inspect oil as described in **Gearcase Lubricant** on p. 39.

Remove gearcase. Refer to **GEARCASE REMOVAL AND INSTALLATION** on p. 318.

Remove water pump. Refer to **WATER PUMP SERVICE** on p. 320.

Before disassembling the gearcase, examine the following:

- **Gearcase Housing** — Check for visible damage to skag, strut, anti-ventilation plate, bullet, and mating surface. Check seal areas for visible signs of lubricant leakage.
- **Propeller Shaft** — Check for bent or damaged shaft. Check for twisted splines and damaged threads.
- **Shift Rod** — Check for misadjusted, bent, or binding rod. A misadjusted shift rod height can cause shift difficulty, loss of boat and outboard control, and gearcase damage.

- **Hydrostatic Seal Grooves** — Must be in good condition to help prevent propeller ventilation.



1. Hydrostatic seal grooves

4557

- **Gearcase Anodes** — If anodes have eroded to two-thirds their original size, they must be replaced.

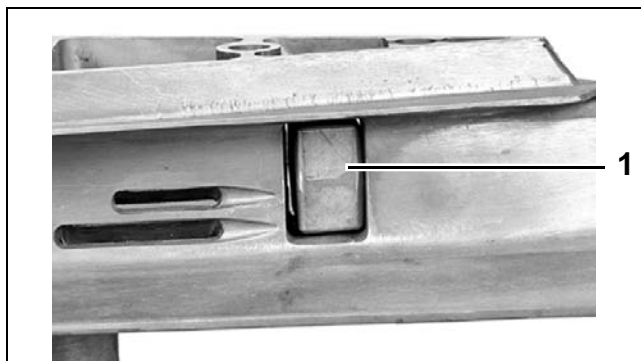

1. Gearcase anode

14161

- **Drive Shaft** — Check splines for visible damage, twisting and wear. Severe spline wear indicates the exhaust housing or gearcase has been distorted, possibly by impact damage.
- **Water Intake Screens** — Check for damage and blockage. If screens cannot be cleaned, they must be replaced. Different screens are available and should not be mixed. Refer to correct model parts manual for listing and description.



## Propeller Shaft Bearing Housing Removal

Remove the two screws, washers, and retainers holding the propeller shaft bearing housing.

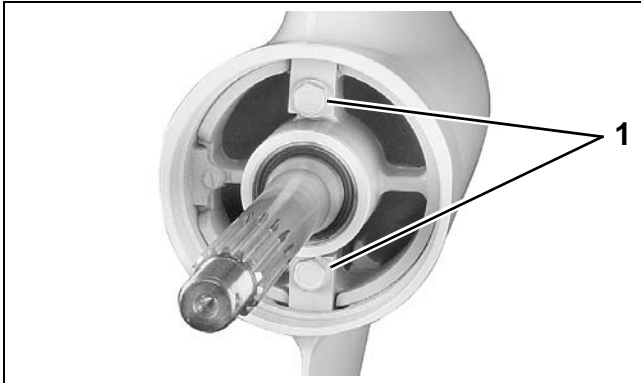

1. Retainer tab screws

001989

Remove wedge, screw, and washer (“O” Type).

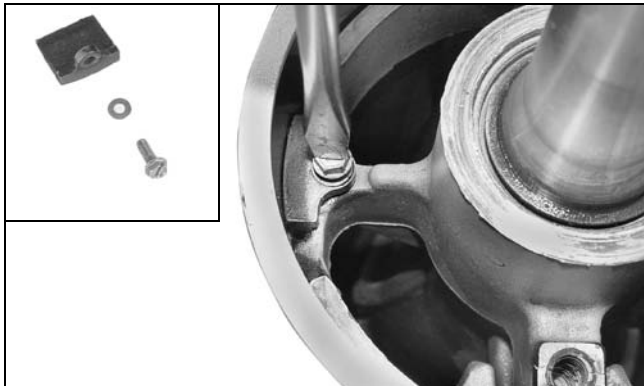

DSM02291  
 DSC02361

Remove the propeller shaft bearing housing from the gearcase using the following:

- Puller body, screw, and handle from Universal Puller Set, P/N 378103.
- Two 5/16-18 x 11 in. (279 mm) threaded rods, two large 5/16 in. I.D. flat washers, and two 5/16-18 nuts (obtain locally).

Assemble components and pull the bearing housing from the gearcase.

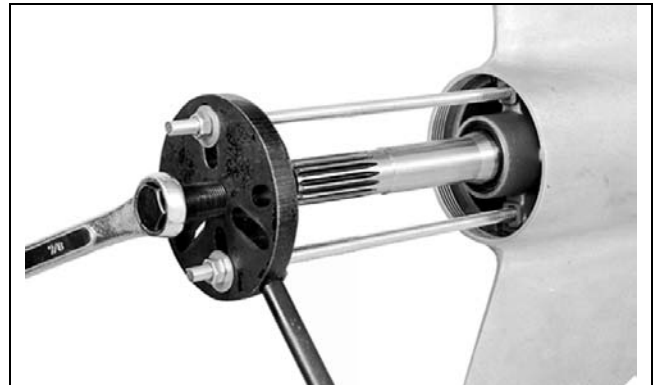

22775

Remove the thrust washer, thrust bearing, and reverse gear from gearcase.

## Pinion Gear and Driveshaft Removal

Adjust the shift rod to move the clutch dog as far forward as possible. This will help ease removal of the pinion nut.

Use Driveshaft Holding Socket, P/N 311875, Pinion Nut Holder, P/N 334455, and Wrench Retainer, P/N 341438 to loosen and remove the pinion nut from the bottom of the driveshaft. Pad handle of holder to prevent damage to gearcase.

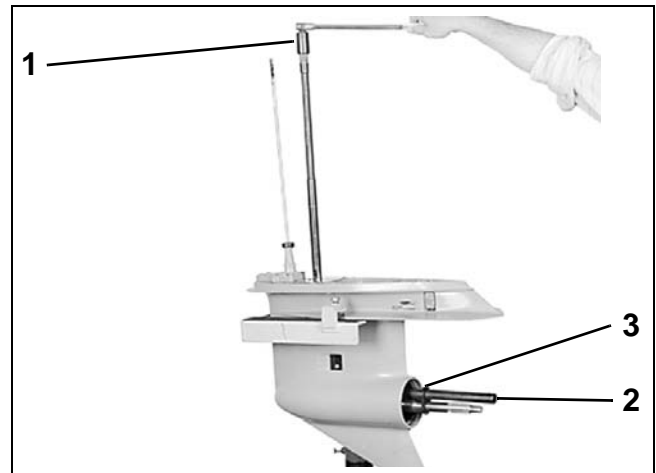

1. Holding socket
2. Pinion holder
3. Retainer

42229

## GEARCASE SERVICE, 75 – 90 HP MODELS

### GEARCASE DISASSEMBLY

Remove the four driveshaft bearing housing screws.

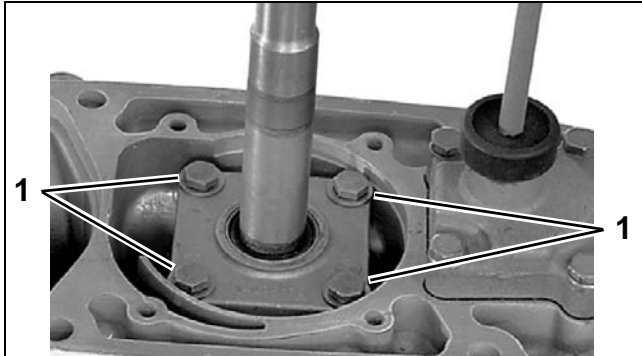

1. Driveshaft bearing housing screws COA3153

Remove the driveshaft from the gearcase. The bearing housing, shims, thrust bearing, and thrust washer will come out with the driveshaft.

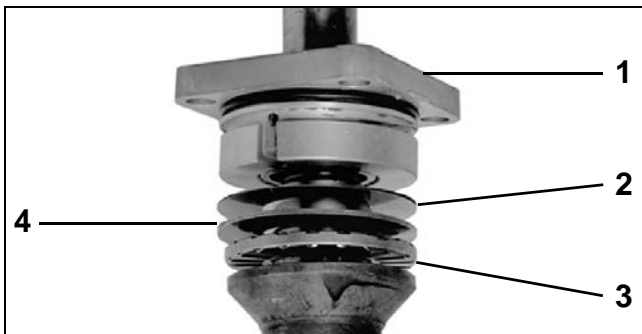

1. Bearing housing COA3558  
 2. Shims  
 3. Thrust bearing  
 4. Thrust washer

If driveshaft cannot be removed, refer to **Locked Driveshaft Removal** on p. 326.

Remove the pinion gear from the gearcase.



COA3159

### Locked Driveshaft Removal

The driveshaft to pinion taper is a locking taper. If necessary, use Driveshaft Puller, P/N 390706, and Backing Plate, P/N 325867, to break the lock. Install the tools as shown by clamping them around the driveshaft. Alternately tighten the two vertical screws against the backing plate inserted between the puller and the gearcase until the driveshaft pops loose from the pinion.

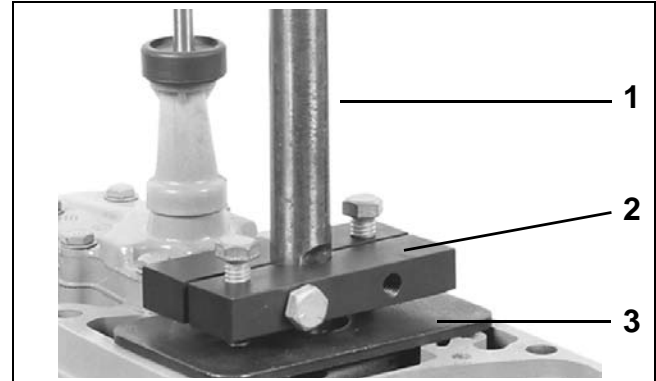

1. Drive shaft 41177  
 2. Puller  
 3. Backing plate

If upper driveshaft becomes separated from lower driveshaft, use Lower Driveshaft Puller, P/N 342681, to remove. Install puller into lower driveshaft and turn 90° to position hook under pin in driveshaft. Thread Slide Hammer, P/N 391008, into puller and remove driveshaft.

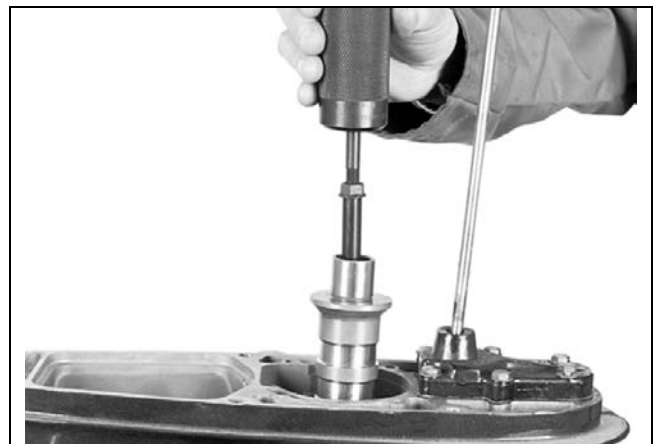

46905

## Driveshaft Service

To separate the upper driveshaft (if needed) from the lower driveshaft, remove the roll pin. Replace the damaged component.

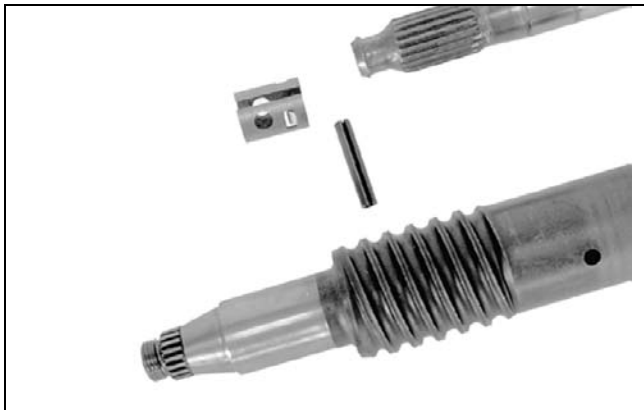

29337

To assemble the driveshaft, install **new** driveshaft retainer into the groove of the upper driveshaft.



29338

Install the upper driveshaft into the lower drive-shaft, aligning the holes in the driveshaft retainer and the lower driveshaft.



29330

## “S” Type Gearcases

Install the roll pin flush.

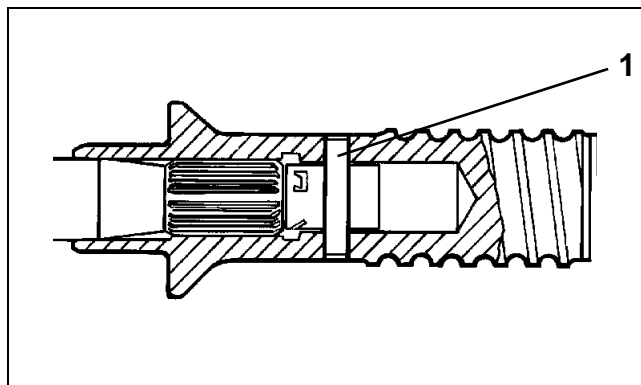

1. Roll pin

DR4596

## “O” Type Gearcases

Install the roll pin to the specified dimension.

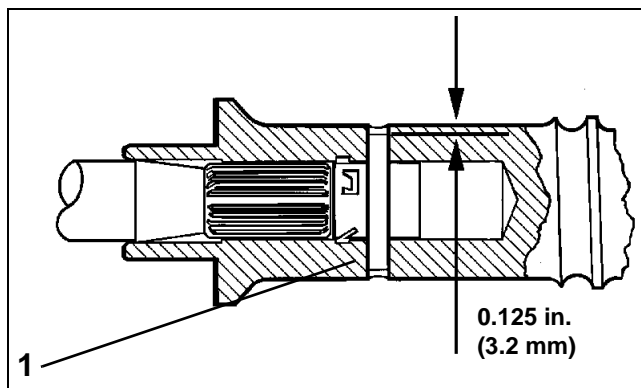

1. Roll pin

DR4610

## GEARCASE SERVICE, 75 – 90 HP MODELS

### GEARCASE HOUSING INSPECTION

#### Shift Housing, Gear and Propeller Shaft Removal

Push down on the shift rod. This will move the detent lever downward to clear the inside of the gearcase when the shaft assembly is pulled out. Unscrew the shift rod from the detent lever. Remove screws, cover, and shift rod from the gearcase.

Discard the cover gasket. Remove and discard the shift rod O-ring from inside of cover.



1. Cover gasket

COA3141

Remove propeller shaft assembly from gearcase.

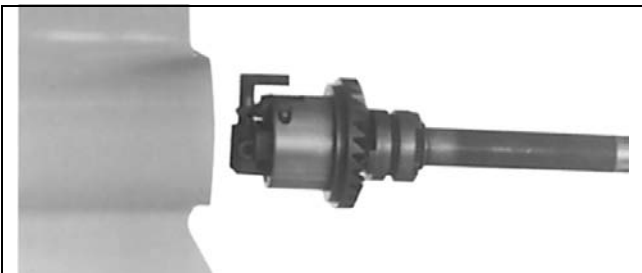

COA3149

#### Water Intake Screens

Remove and clean water intake screens. Replace if damaged.

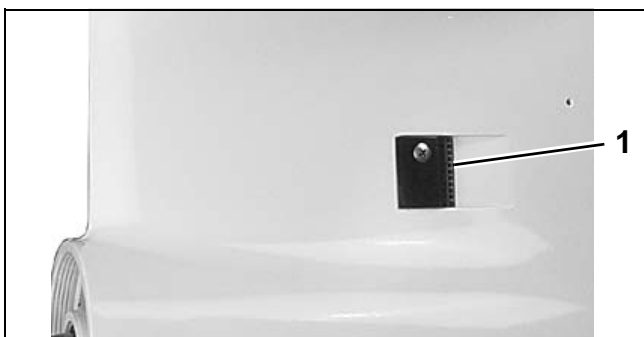

1. Water intake screen

001991

## GEARCASE HOUSING INSPECTION

Thoroughly clean gearcase housing to remove all dirt and debris prior to inspection. Inspect pinion bearing and forward thrust surface of gearcase housing.

Use Gearcase Alignment Gauge Kit, P/N 5006349 to check the condition of gearcase housing prior to reassembly. Refer to instructions provided with kit. Use additional Gauging Head as follows:

- P/N 352879, for "S" Type gearcases.

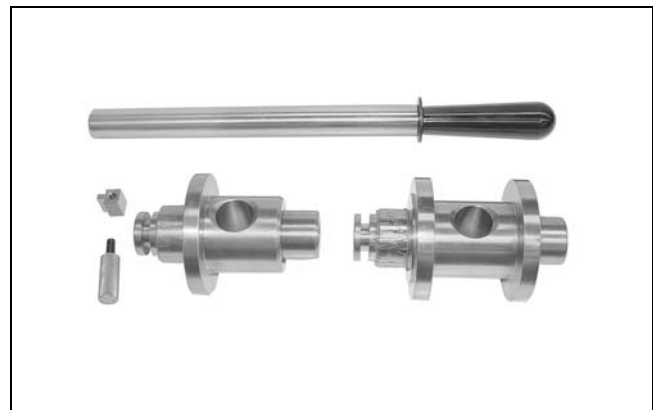

004315

**IMPORTANT:** DO NOT force gauging shaft into alignment hole. Shaft **MUST** slide easily into hole of gauging head. If shaft does not slide into hole, gearcase housing is damaged and **must** be replaced.



1. Gauging shaft

004347

# SHIFTER, BEARING AND SEAL SERVICE

## Pinion Bearing Removal

Remove pinion bearing retaining screw.

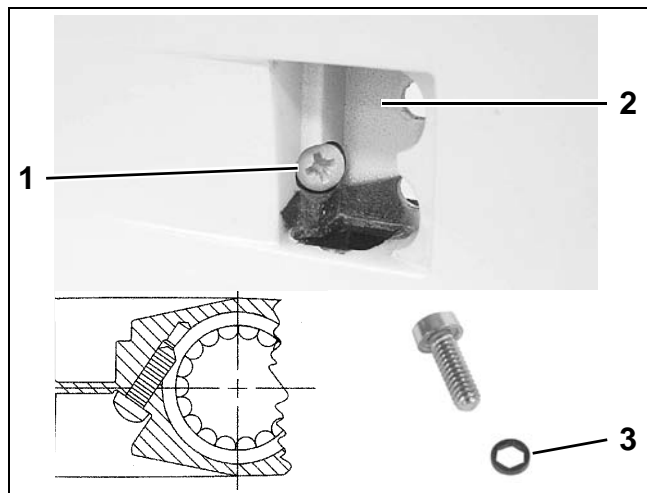

- |                                   |          |
|-----------------------------------|----------|
| 1. Pinion bearing retaining screw | DSC02370 |
| 2. Water screen pocket            | DRC7416  |
| 3. Seal                           | DSC02313 |

Assemble Pinion Bearing Remover/Installer, P/N 5005927, in the gearcase as follows:

### “S” Type Gearcases

Use a mallet to drive the bearing from the housing.

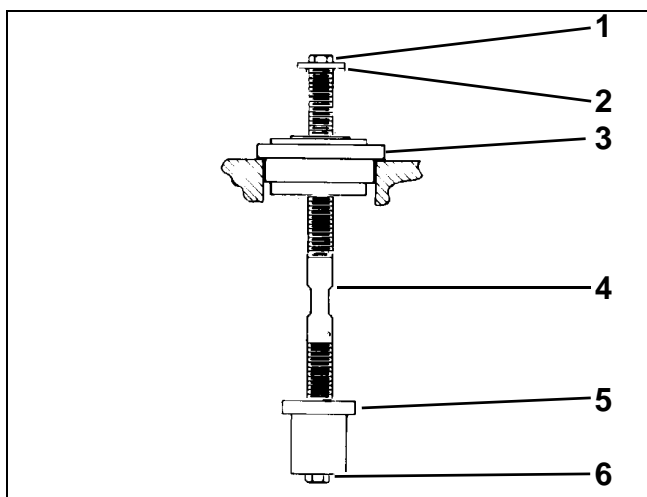

- |                                      |        |
|--------------------------------------|--------|
| 1. 1/4-20 x 1/2 in. Hex Head Screw   | 824163 |
| 2. 1 in. O.D. Flat Washer            |        |
| 3. Plate, P/N 391260                 |        |
| 4. Rod, P/N 326582                   |        |
| 5. Installer/Remover, P/N 326574     |        |
| 6. 1/4-20 x 1 1/4 in. Hex Head Screw |        |

### “O” Type Gearcases

Use a 7/8 in. wrench to hold the remover in place. Use a 3/4 in. wrench to turn flange nut clockwise. Draw the bearing up from the housing.

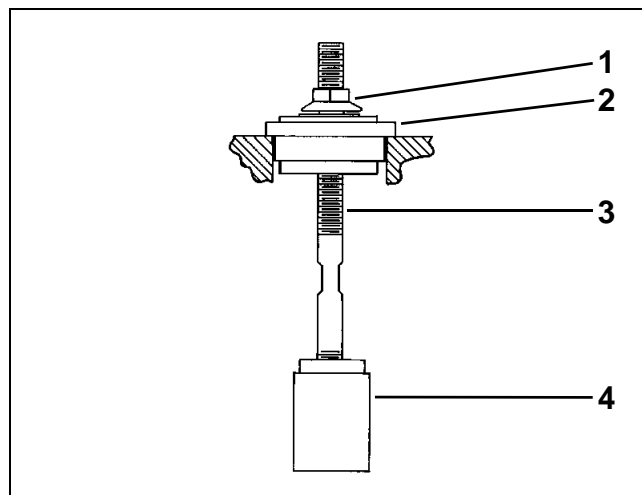

- |                           |        |
|---------------------------|--------|
| 1. Flange nut, P/N 326586 | DR3419 |
| 2. Plate, P/N 391260      |        |
| 3. Rod, P/N 326582        |        |
| 4. Remover, P/N 326579    |        |

## Pinion Bearing Installation

Assemble the following components of Pinion Bearing Remover and Installer, P/N 5005927, as shown:

### “S” Type Gearcases

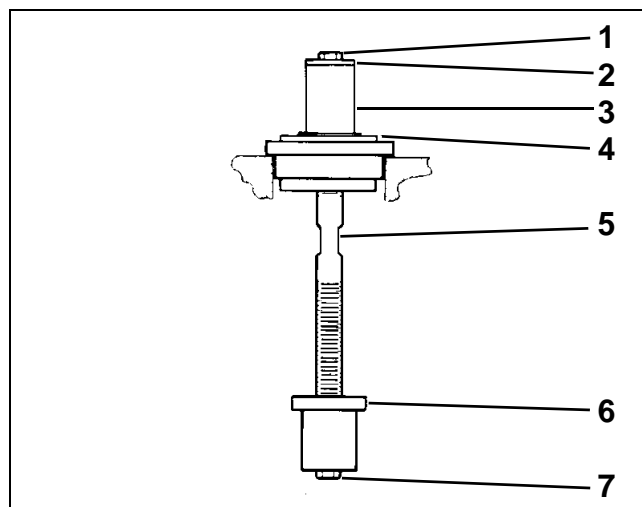

- |                                      |        |
|--------------------------------------|--------|
| 1. 1/4-20 X 1/2 in. Hex head screw   | 824182 |
| 2. 1 in. O.D. Flat washer            |        |
| 3. Spacer, P/N 341437                |        |
| 4. Plate, P/N 391260                 |        |
| 5. Rod, P/N 326582                   |        |
| 6. Installer/Remover, P/N 326574     |        |
| 7. 1/4-20 X 1 1/4 in. Hex head screw |        |

## GEARCASE SERVICE, 75 – 90 HP MODELS SHIFTER, BEARING AND SEAL SERVICE

### “O” Type Gearcases

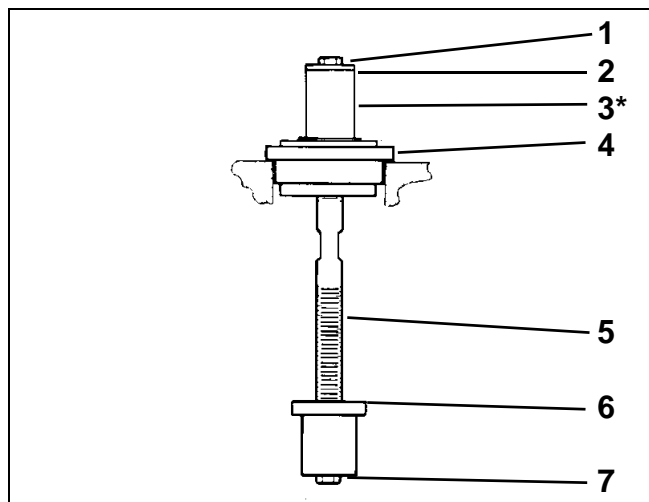

1. 1/4-20 X 1/2 in. Hex head screw
2. 1 in. O.D. Flat washer
3. Spacer, P/N 326584
4. Plate and Bearing P/N 391260
5. Rod P/N 326582
6. Installer/Remover, P/N 350958
7. 1/4-20 X 1 1/4 in. Hex head screw

824182

**IMPORTANT:** Spacers are different sizes and cannot be interchanged.

Apply *Needle Bearing* grease to the needle bearings and insert them into the bearing case (“O” Type gearcases).

Place the bearing on the installer tool with the **lettered side of the bearing facing the top** of the gearcase. Use *Needle Bearing* grease to hold the bearing on the tool.

**IMPORTANT:** The pinion bearing is tapered so that, when installed correctly, its shape compensates for stresses in the gearcase and allows full bearing contact. Whenever a gearcase is disassembled, the pinion bearing should be checked to ensure that it has been installed with the lettering facing up.

Insert the tool with the bearing into the gearcase. Drive the bearing into the gearcase until the washer on the tool contacts the spacer.

Remove the tool.

Place a new O-ring on the pinion bearing retaining screw. Apply *Gasket Sealing Compound* to O-ring. Apply *Nut Lock* to screw threads. Install the screw and tighten to a torque of 60 to 84 in. lbs. (7 to 9.5 N·m).

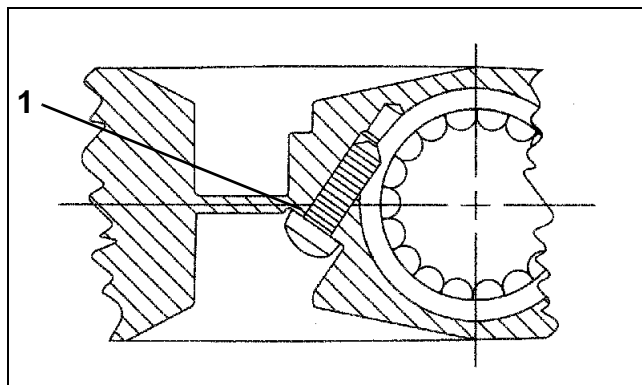

1. O-ring

DRC7416

### Shift Housing Disassembly

#### **WARNING**

**Wear safety glasses to avoid injury.**

**IMPORTANT:** The shift housing and bearing are serviced as an assembly. If either are worn or damaged, replace the complete assembly.

Insert a suitable tool under one end of the clutch dog spring and remove it from its groove by unwrapping it from around the clutch dog. **Discard the spring.**

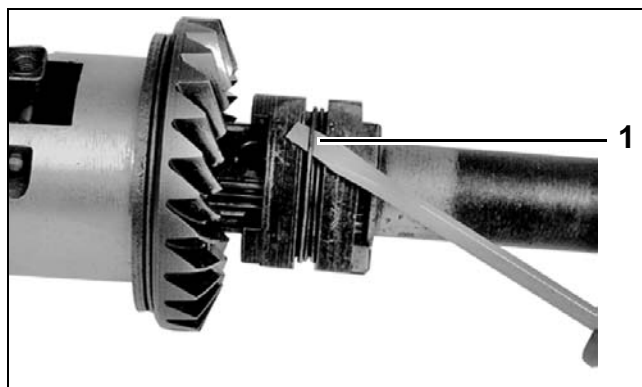

1. Clutch dog spring

COA3560

## GEARCASE SERVICE, 75 – 90 HP MODELS SHIFTER, BEARING AND SEAL SERVICE

Push the pin out of the clutch dog. Remove all parts.

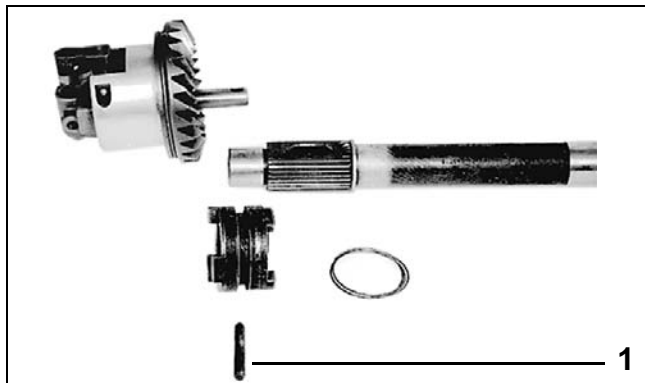

1. Pin

COA3561

Remove the gear, thrust bearing, and thrust washer from the shift housing.

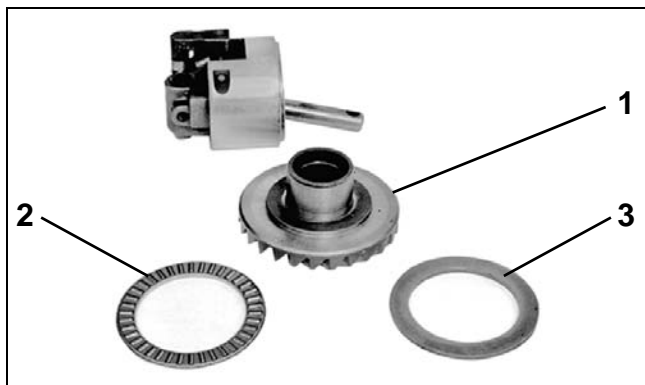

1. Gear
2. Thrust bearing
3. Thrust washer

COA3562

Remove the shift lever pin from the housing. Remove shift shaft, cradle and shift lever. Move

shifter detent as needed to help ease removal of parts.

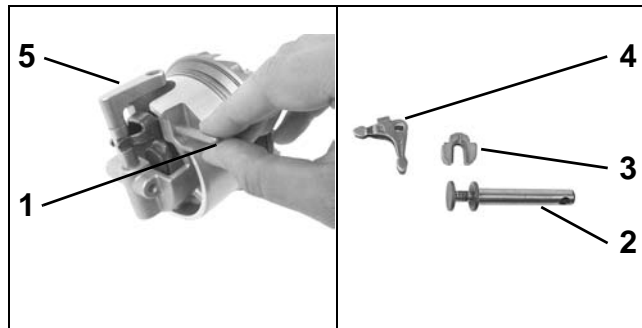

1. Shift lever pin
2. Shift shaft
3. Cradle
4. Shift lever
5. Shifter detent

DSC02449

DSC02489

### **⚠ WARNING**

**Wear safety glasses to avoid personal injury. The detent ball and spring and come out with great force.**

Wrap the housing with a shop cloth to catch ball and spring. Rotate the shifter detent 90° in either direction, then pull the detent out of the housing.

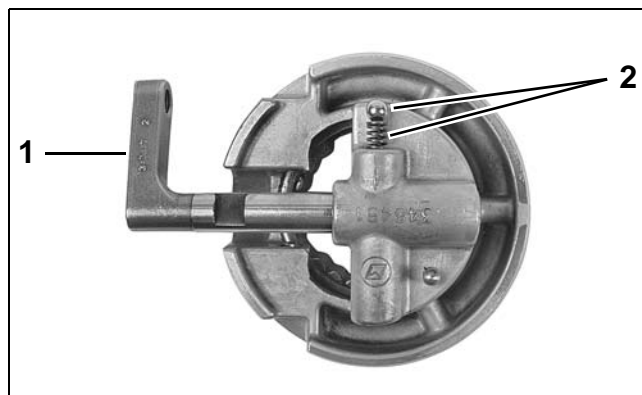

1. Shifter detent
2. Ball and spring

DSC02518

Remove the detent ball and spring.

Remove needle bearings from bearing housing for cleaning and inspection ("O" Type).

## Shift Housing Assembly

**IMPORTANT:** Clean and inspect all parts before beginning assembly procedures. Replace any damaged parts.

Lightly coat the detent ball and spring with *Needle Bearing* grease. Insert the spring in the housing, then the ball.



4518

Insert shifter detent at 90° angle into the housing as shown, while depressing the ball and spring with a suitable tool. Once the shifter detent is past the ball, remove the tool and position detent to engage NEUTRAL position.

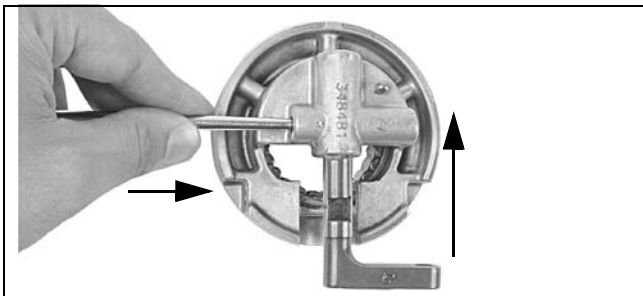

DSC02506

Thoroughly grease 25 needle bearings with *Needle Bearing* grease and place in the bearing case ("O" Type gearcases).



4520

With shifter detent in NEUTRAL, install arms of shift lever into detent slots. Align the pivot holes and insert the retaining pin. Push shifter detent down.

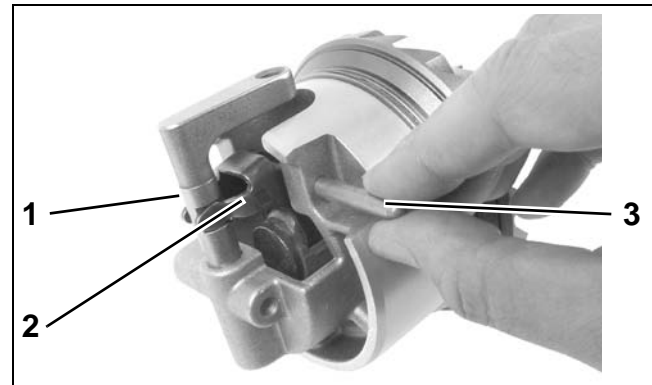

1. *Shifter detent*
2. *Shift lever*
3. *Pin, shift lever*

DSC02449

Rest the cradle on the shift shaft.

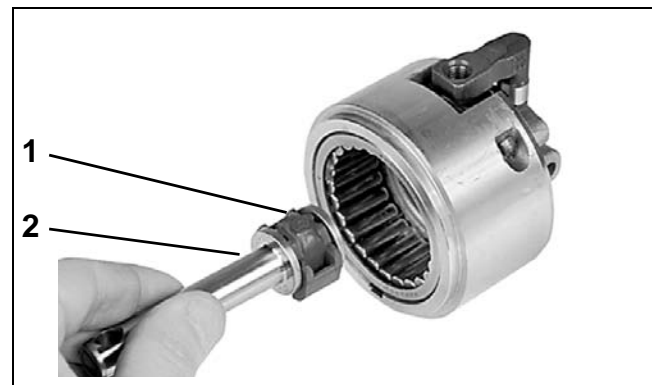

- TYPICAL**
1. *Cradle*
  2. *Shift shaft*

4512



## GEARCASE SERVICE, 75 – 90 HP MODELS SHIFTER, BEARING AND SEAL SERVICE

Place the shift lever arms into the recesses of the shift cradle. Pull shifter detent back up to NEUTRAL position to hold the cradle and shaft in place.



001219

Coat thrust bearing and thrust washer with *Needle Bearing* grease. Place the bearing on the back of the gear. Set the washer on top of the thrust bearing. Insert the gear, bearing, and washer into the bearing housing.

**NOTICE** Bearing and washer must be installed in the correct order.

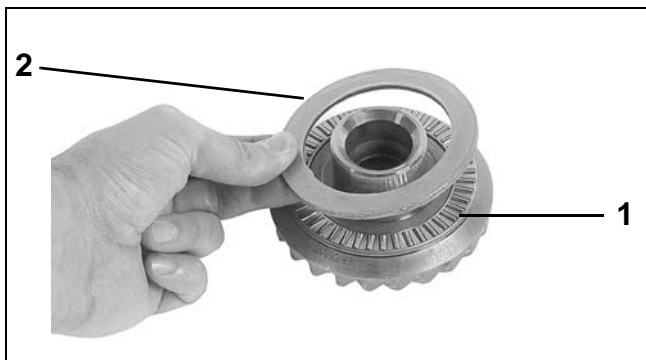

1. Thrust bearing
2. Thrust washer

DSC02297

Align holes in the clutch dog with slot in the propeller shaft. Install the clutch dog on the shaft with "PROP END" facing rear of the shaft.

**NOTICE** The clutch dog is not symmetrical. If installed backward, it will not fully engage and will immediately damage itself and the gears.



1. "PROP END"

COB7581

Slide the propeller shaft onto the shift shaft, align the hole in the shaft with the hole in the clutch dog, install the pin and then, a **new** clutch dog retaining spring. Place three coils over each end of the pin, MAKING SURE NONE OF THE COILS OVERLAP OR ARE LOOSE.

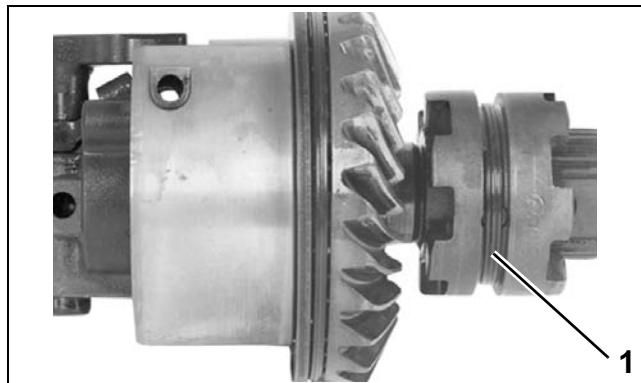

1. Retaining spring

COB3101

## Driveshaft Bearing Housing Service

The driveshaft bearing is not serviceable. Replace the bearing housing assembly if the bearing is worn or damaged. Also, inspect the driveshaft bearing surface if the bearing is damaged.

### Seal Removal

Remove the driveshaft bearing housing seals using Puller Bridge, P/N 432127, and Large Puller Jaws, P/N 432129. Discard the seals.



14155

Remove and discard the O-ring from the bearing housing.

Clean the bearing housing in solvent to remove sealer from the seal bore and the O-ring groove.

### Seal Installation

Lightly apply *Gasket Sealing Compound* to a new O-ring. Install the O-ring in top groove of the bearing housing. Do not allow sealant in oil passage.

**NOTICE** Do not install the O-ring in the bearing housing's bottom groove. The bottom groove is an oil passage. Gearcase damage could result.

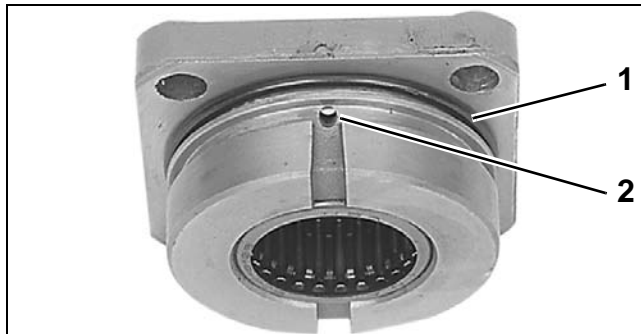

1. O-ring (top groove)
2. Oil passage

14156

Apply *Gasket Sealing Compound* to casings of new seals before installing.

Use Seal Installation Tool, P/N 330268 to install new seals back to back in bearing housing. Install inner seal with lip facing toward bearing housing, then the outer seal with lip facing away from bearing housing. Apply *Triple-Guard* grease to seal lips.

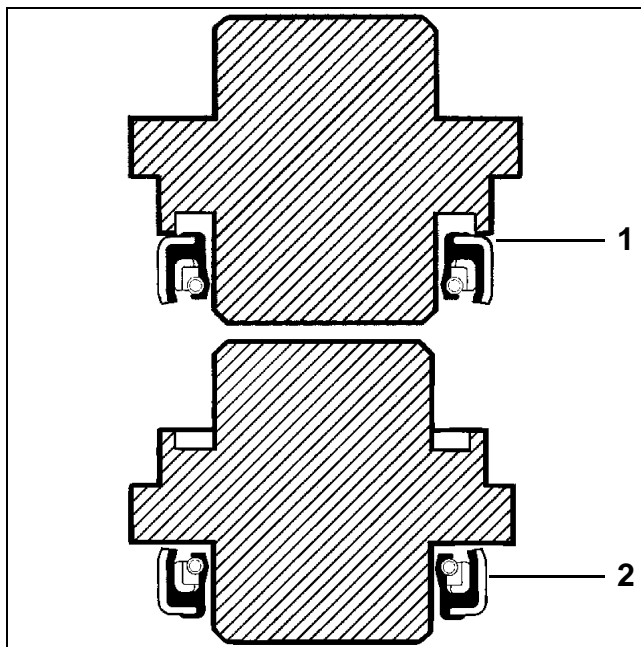

1. Inner seal
2. Outer seal

DR2061  
DR2062

## Propeller Shaft Bearing Housing Service

### Rear Seal Removal

Remove seals using Puller Bridge, P/N 432127, and Small Puller Jaws, P/N 432131. Place the plate on top of the housing to support the bridge, and tighten jaws securely behind the inner seal.



13520

### Bearing Removal

**IMPORTANT:** Inspect bearings in place. If a bearing is removed for any reason, it must be discarded.

Remove either bearing using Puller Bridge, P/N 432127, and Large Puller Jaws, P/N 432129. Place the puller plate on top of the housing to support the bridge, and tighten jaws securely behind the bearing.



13522

Inspect the bearing housing anode. Replace anode if it is reduced to two-thirds of original size. Tighten screws to a torque of 108 to 132 in. lbs. (12 to 15 N-m).

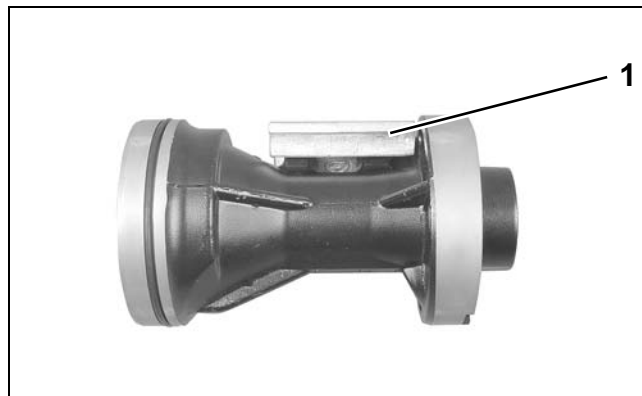

1. Anode

001220

Discard the bearing housing O-ring. Clean the housing and bearings in solvent and dry thoroughly. If bearings were not replaced, rotate the needles to check for freedom of movement.

Inspect O-ring groove. Sand off any sharp edges that might cut O-ring. Remove any nicks or burrs on front of bearing housing.



1. O-ring groove

DSC02291

# GEARCASE SERVICE, 75 – 90 HP MODELS

## SHIFTER, BEARING AND SEAL SERVICE

### Bearing Installation

Oil, then install new bearings in bearing housing.

Place the **lettered end** of the bearing case on the bearing installer, then press the bearing into the housing until the tool seats. When installed, the lettered end of the bearing should be visible.

Bearing installation tool:

- P/N 326562 – “S” Type gearcases
- P/N 339750 – “O” Type gearcases



**Forward Bearing**

1. Bearing installation tool

29967



**Rear Bearing**

1. Bearing installation tool

44237

### Rear Seal Installation

Apply *Gasket Sealing Compound* to metal casings of the seals before installing.

Use Seal Installation Tool to install new seals back to back in bearing housing.

Seal installation tool:

- P/N 326551 – “S” Type gearcases
- P/N 336311 – “O” Type gearcases

Install inner seal with lip facing toward the bearing housing, then outer seal with lip facing away from the bearing housing.

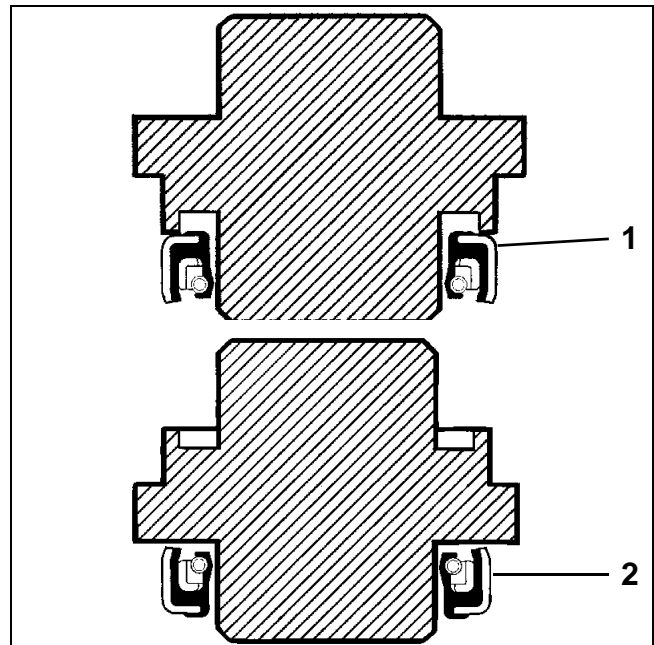

1. Inner seal  
2. Outer seal

DR2061  
DR2062

Apply *Triple-Guard* grease to seal lips.

## DRIVESHAFT SHIMMING

**NOTICE** If a new pinion gear is needed, replace gear set before shimming.

Pinion gear backlash is achieved by using shims between the driveshaft bearing housing and the thrust washer. When installing a new thrust bearing or washer, bearing housing, pinion, or driveshaft, it is necessary to properly shim the assembly to restore factory clearance.

Use Driveshaft Shimming Tool, P/N 5005925 (replaces P/N 393185).

Shim gauge bars are precision made and should be handled carefully. The length of each bar is stamped near the part number. This dimension is 0.020 in. (0.508 mm) shorter than the actual shimmed length of the driveshaft.

**IMPORTANT:** Clean pinion and driveshaft before assembly. Replace any damaged parts.

Assemble the driveshaft bearing housing, thrust washer, thrust bearing, and pinion onto the driveshaft. Use Driveshaft Seal Protector, P/N 318674, when installing or removing the bearing housing.

Lightly coat the threads of the pinion nut with out-board lubricant and tighten to a torque of 100 to 110 ft. lbs. (136 to 149 N·m).

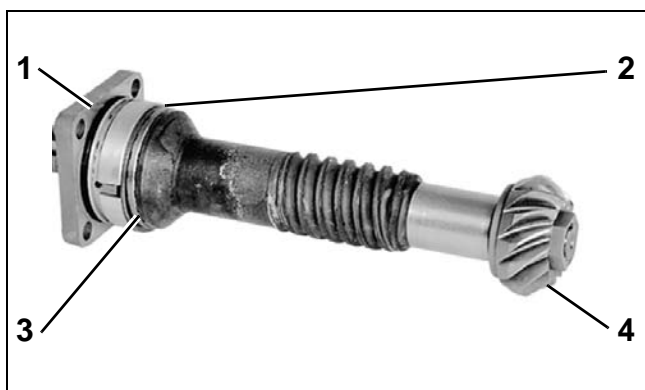

1. Driveshaft bearing housing COA3565  
2. Thrust washer  
3. Thrust bearing  
4. Pinion

**IMPORTANT:** The original pinion nut may be used for shimming, but must **NOT** be used in final assembly.

Select correct collar and shim gauge bar:

- Collar: P/N 341440
- Shim gauge bar: P/N 328367

Slide the collar onto the driveshaft with large end in contact with the bearing housing.

Insert the assembled driveshaft into the tool base and tighten preload screw against the driveshaft until groove on the spring-loaded plunger is flush with end of threads. Tighten locking ring on preload screw.

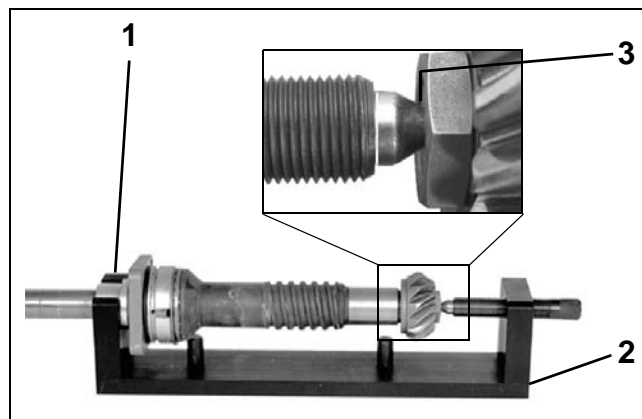

1. Collar  
2. Tool base  
3. Groove

COA3566  
DSC00326

Rotate the driveshaft several revolutions to seat bearings.

Lay the tool base on its side. Position the shim gauge bar against guide pins of the tool base.

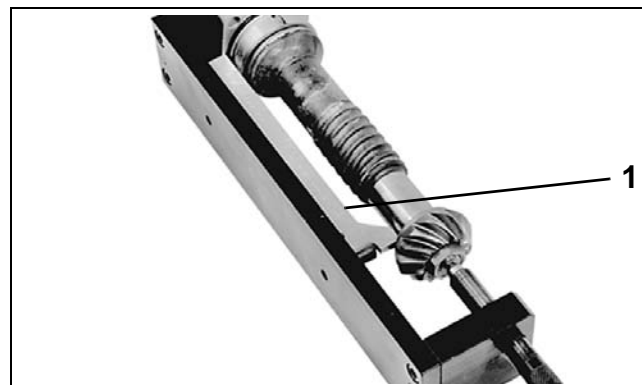

1. Shim gauge bar

COA3567

Check squareness of the bearing housing mounting surface by holding the shim gauge bar against the pinion while rotating **just the bearing housing**. Use a feeler gauge to measure clearance

## GEARCASE SERVICE, 75 – 90 HP MODELS

### GEARCASE ASSEMBLY

between the gauge bar and the bearing housing between each pair of screw holes. Replace the bearing housing and repeat check if variance is greater than 0.004 in. (0.101 mm).

Check squareness of the pinion to the driveshaft. Hold the shim gauge bar against the bearing housing (between the screw holes) while rotating **just the driveshaft and pinion assembly**. Measure clearance between the gauge bar and the pinion at several locations. If variance is greater than 0.002 in. (0.050 mm) replace the pinion or driveshaft, as necessary, and repeat check.

Subtract the average clearance measurement from 0.020 in. (0.508 mm) to determine the correct shim thickness required. Select the fewest number of shims to achieve the correct thickness.

Remove the driveshaft from the tool and add the required shims between the bearing housing and the thrust washer.

**IMPORTANT:** Use extreme care when removing bearing housing to avoid damaging the seals. Use Driveshaft Seal Protector, P/N 318674.

Check clearance again. The measurement between the gauge bar and pinion should be 0.020 in. (0.508 mm).

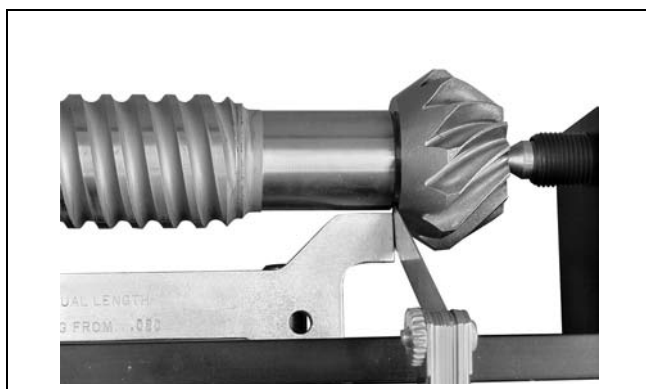

005417

Remove the nut and pinion from the driveshaft. Discard the nut.

## GEARCASE ASSEMBLY

### Water Intake Screens

Install water intake screens. Tighten screws to a torque of 60 to 84 in. lbs. (7 to 9.5 N·m).

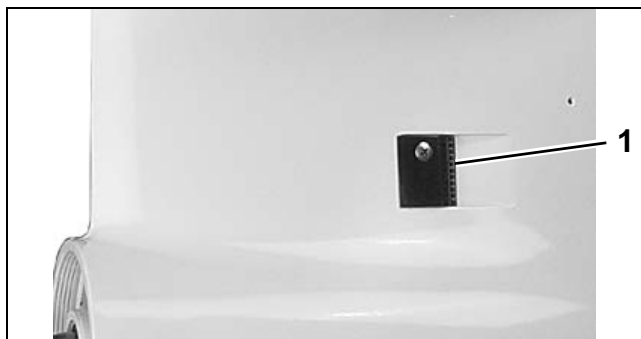

1. Water intake screen

001991

### Shift Housing, Gear, and Propeller Shaft Installation

Push shifter detent into farthest downward position. Tip the rear of the gearcase slightly downward to assist in the installation of the shaft assembly.

Be sure the thrust bearing and the thrust washer are in the proper position. Insert the shaft assembly fully into the gearcase while aligning shift housing pin with hole in forward end of gearcase housing.

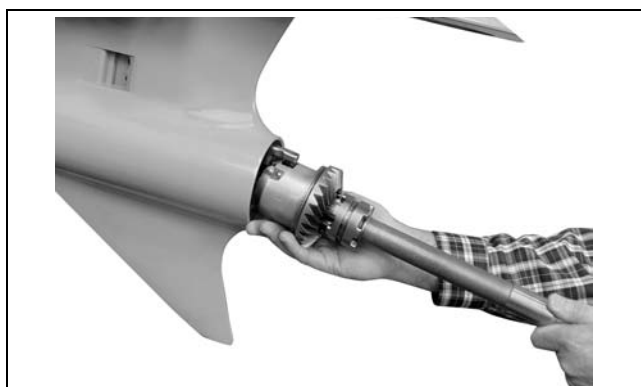

005427

## Shift Rod Housing Installation

Lubricate a new shift rod cover O-ring with *Triple-Guard* grease. Install the O-ring into the shift rod cover.

**IMPORTANT:** Make sure O-ring is fully seated in groove.

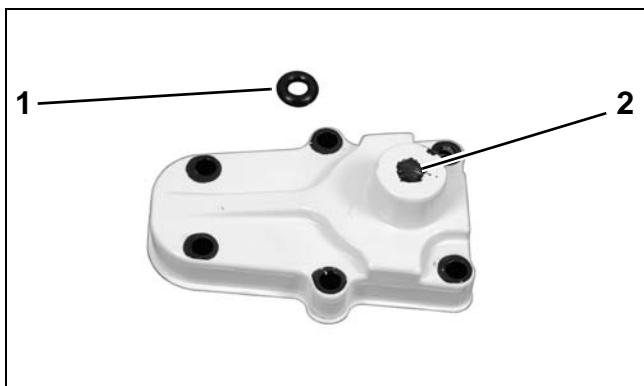

1. O-ring
2. Groove

006780

Place the shift rod grommet on the shift rod.

Install shift rod spacer under grommet on 25 in. models.

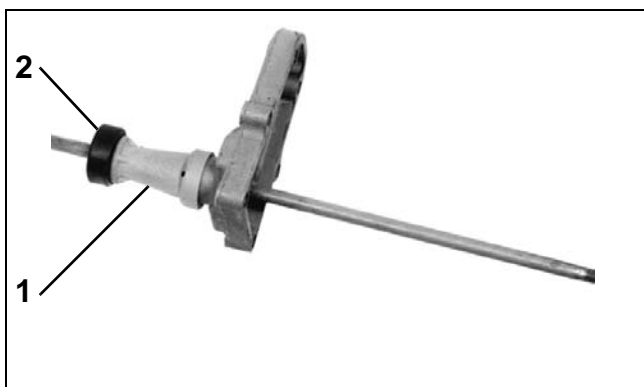

1. Grommet
2. Shift rod spacer

COA3568

Apply *Triple-Guard* grease to the threaded end of the shift rod and insert it through the cover. Turn the shift rod while pushing it through the cover to avoid damaging the O-ring.

Apply *Gasket Sealing Compound* to both sides of a new shift rod cover gasket. Place the gasket on the gearcase.

Thread the shift rod into the shifter detent about four turns.

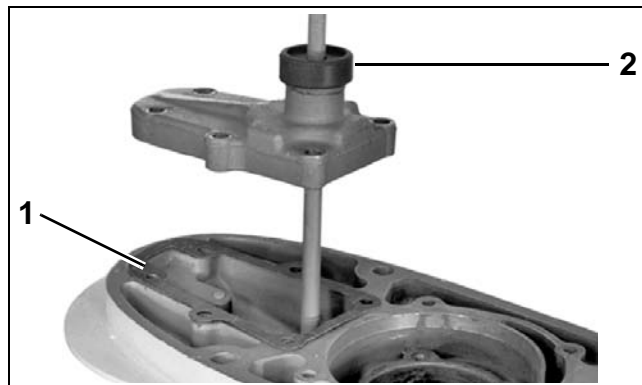

1. Cover gasket
2. Grommet

COA3141

Move shift rod from side to side while pushing on the propeller shaft to ensure proper alignment of the bearing housing locator pin into the pin hole in the gearcase.

Apply *Gasket Sealing Compound* to the threads of the shift rod cover screws. Tighten the screws to a torque of 60 to 84 in. lbs. (7 to 9.5 N·m).



COA3569

Refer to **SHIFT ROD ADJUSTMENT** on p. 323.

## Pinion Gear and Driveshaft Installation

Refer to **DRIVESHAFT SHIMMING** on p. 337 before proceeding.

Install new seals in driveshaft bearing housing. Refer to **Driveshaft Bearing Housing Service** on p. 334.

Place the driveshaft thrust bearing, thrust washer, and correct shim(s) on the driveshaft as shown.

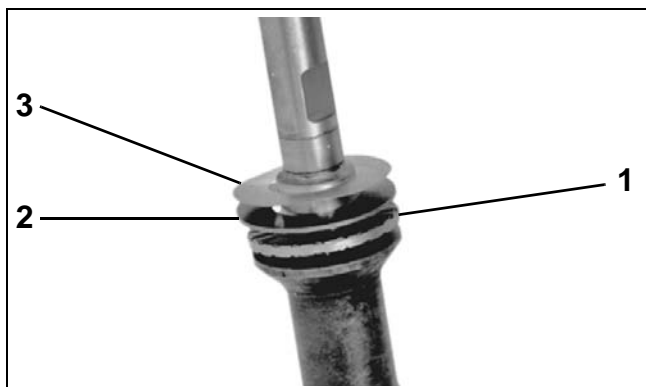

1. Thrust bearing  
2. Thrust washer  
3. Shim(s)  
COA3168

Using Driveshaft Seal Protector, P/N 318674, slide the driveshaft bearing housing onto the driveshaft and into position in the gearcase.

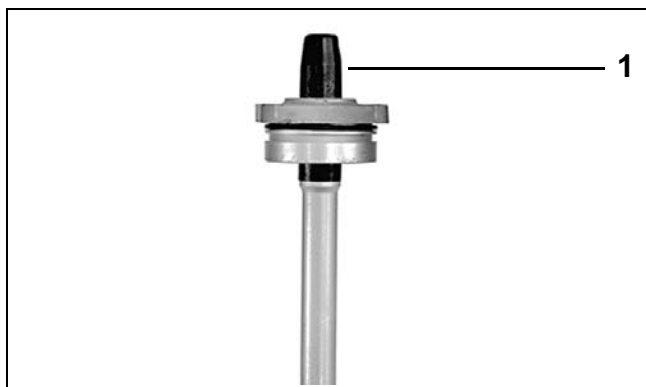

1. Seal protector  
COA3130

Adjust shift rod to move clutch dog as far forward as possible. Be sure excess grease is removed from the pinion bearing.

**IMPORTANT:** The inside taper of the pinion gear and the driveshaft taper **MUST** be completely free of grease. Clean the tapers with *Cleaning Solvent*. Use a shop towel free of grease and lint.

Place the pinion gear into the gearcase. Insert the driveshaft into the gearcase and through the pinion gear.

Lightly coat the threads of a **new** pinion nut with outboard lubricant. Use Pinion Nut Starting Tool, P/N 342216, to install nut on the driveshaft. Turn the driveshaft by hand to thread the nut on to shaft.

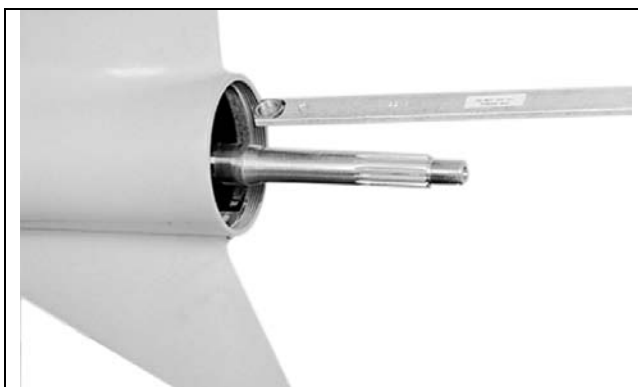

42230

Apply *Gasket Sealing Compound* to the threads of the driveshaft bearing housing screws. Tighten screws **in stages** to a torque of 120 to 144 in. lbs. (13.5 to 16.5 N·m).

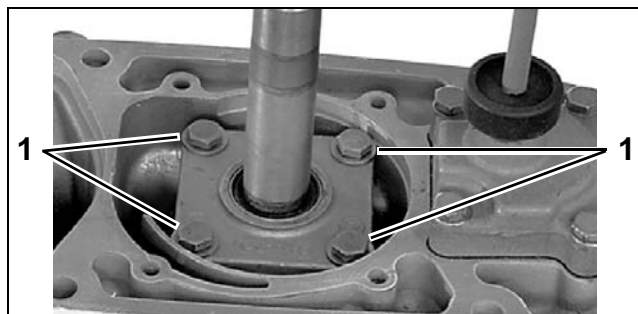

1. Driveshaft bearing housing screws  
COA3153



Use Driveshaft Holding Socket, P/N 311875, Pinion Nut Holder, P/N 334455, and Wrench Retainer, P/N 341438, to tighten the pinion nut to a torque of 100 to 110 ft. lbs. (136 to 149 N·m). Pad handle of holder to prevent damage to gearcase.



1. Holding socket  
 2. Pinion holder  
 3. Retainer  
 42229

## Propeller Shaft Bearing Housing and Gear Installation

Oil and install thrust bearing and thrust washer on hub of reverse gear. Slide the gear assembly onto the propeller shaft until it engages the pinion gear.

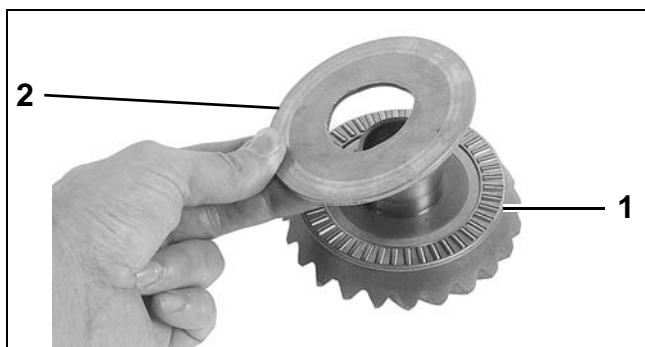

1. Thrust bearing  
 2. Thrust washer  
 DSC02295

Lightly apply *Gasket Sealing Compound* to a new bearing housing O-ring. Install O-ring in groove in the housing.

Install housing into gearcase. Align screw holes with retainer slots in gearcase.

Housing must be completely seated to install retainer tabs.

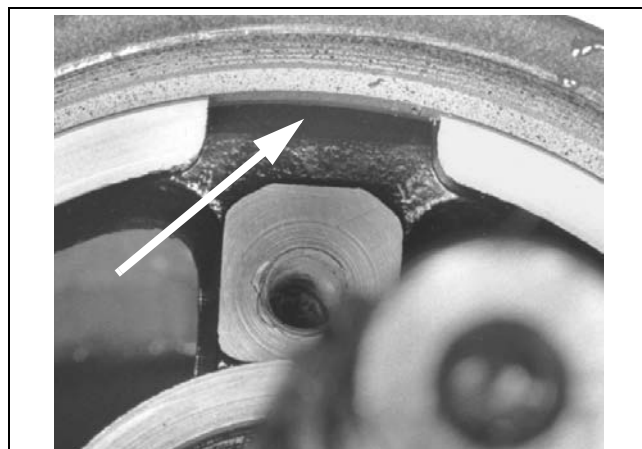

Retainer Tab Notch  
 50106a

Install two retainers, washers and screws. Apply *Ultra Lock* to threads and tighten screws to a torque of 18 to 20 ft. lbs. (24 to 27 N·m).

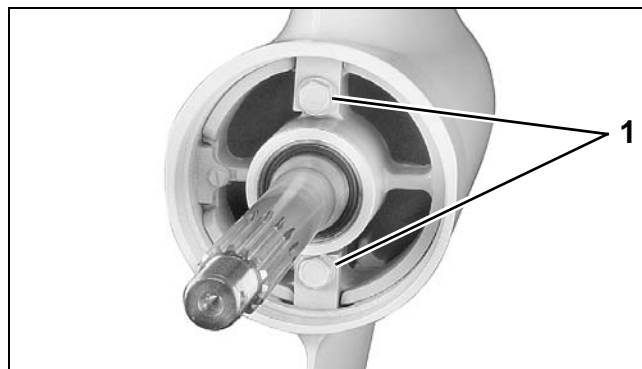

1. Retainer tab screws  
 001989

---

## GEARCASE SERVICE, 75 – 90 HP MODELS

### GEARCASE ASSEMBLY

---

#### “O” Type Gearcases

Loosen retainer screws 1/4 turn.

Install wedge, screw, and washer. Apply *Ultra Lock* to threads and tighten screw to a torque of 15 to 20 in. lbs. (1.7 to 2.3 N·m).

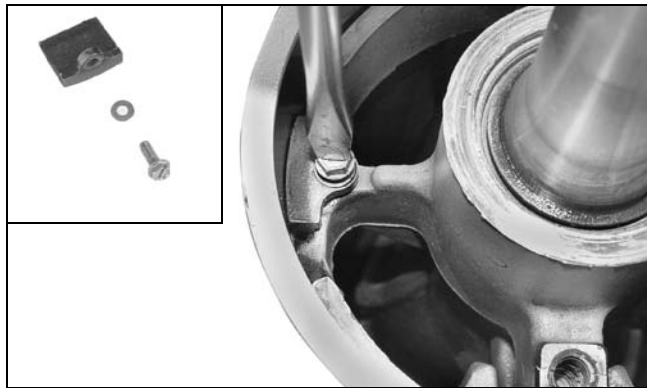

DSM02291  
DSC02361

Re-tighten two retainer screws to 18 to 20 ft. lbs. (24 to 27 N·m).

Confirm that torque on the wedge screw is 15 to 20 in. lbs. (1.7 to 2.3 N·m).

#### Final Assembly and Adjustment

To complete gearcase assembly, refer to:

- **GEARCASE LEAK TEST** on p. 295
- **WATER PUMP SERVICE** on p. 320
- **SHIFT ROD ADJUSTMENT** on p. 323
- **GEARCASE REMOVAL AND INSTALLATION** on p. 318
- **Gearcase Lubricant** on p. 39
- **Propeller Hardware Installation** on p. 294
- **Trim Tab Adjustment** on p. 31.

During break-in period of a reassembled gearcase, change the gearcase lubricant between 10 to 20 hours of operation.

# TRIM AND TILT

## TABLE OF CONTENTS

SERVICE CHART .....	344
SYSTEM DESCRIPTION .....	346
MANUAL ADJUSTMENT .....	346
TRAILERING BRACKET AND TILT SUPPORT .....	346
ROUTINE INSPECTIONS .....	348
GENERAL .....	348
RESERVOIR FLUID .....	348
MANUAL RELEASE VALVE .....	348
STERN BRACKETS .....	348
TROUBLESHOOTING .....	348
ELECTRICAL CIRCUIT TESTS .....	349
RELAY TESTING .....	349
TRIM AND TILT MOTOR CURRENT DRAW TESTS .....	349
TRIM AND TILT MOTOR NO LOAD TEST .....	350
TRIM GAUGE TEST .....	351
TRIM SENDER TEST .....	351
TRIM AND TILT REPLACEMENT .....	352
REMOVAL .....	352
INSTALLATION .....	354
TRIM AND TILT SERVICE .....	356
DISASSEMBLY .....	356
ASSEMBLY .....	358

# SERVICE CHART

40 - 60 HP MODELS

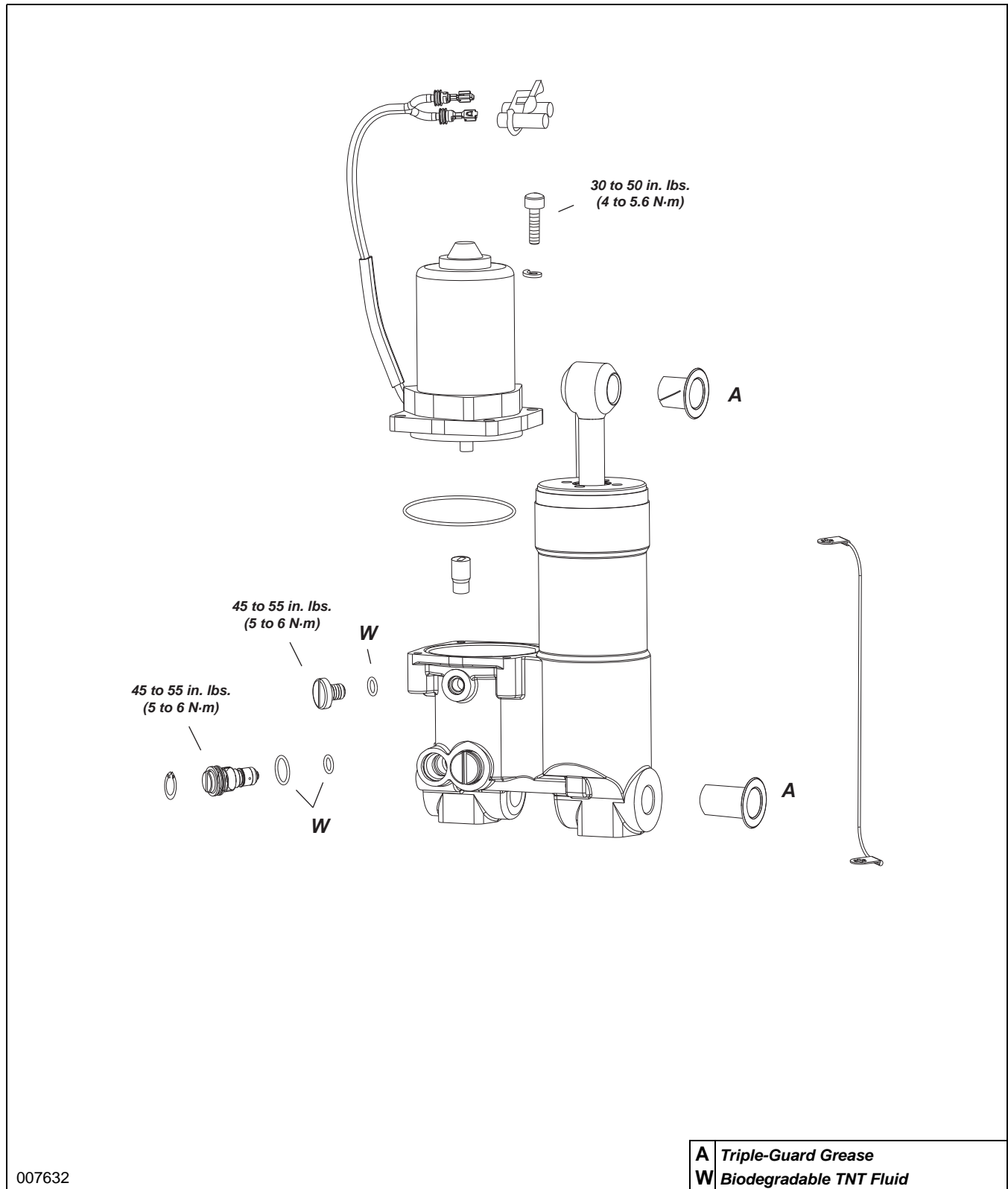

007632

75 - 90 HP MODELS

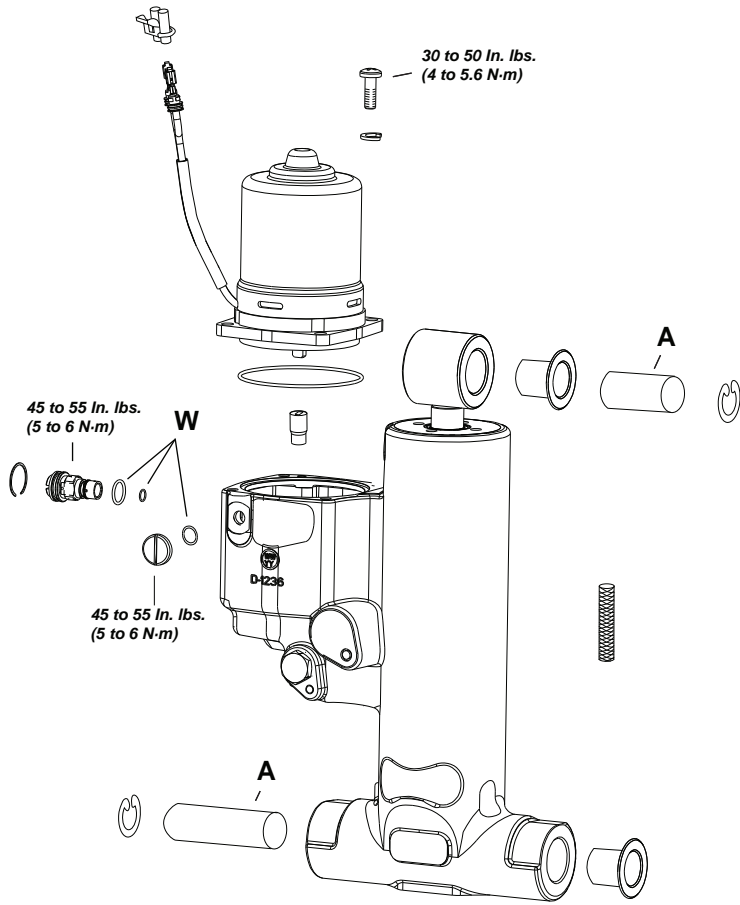

005002

<b>A</b>	Triple-Guard Grease
<b>W</b>	Biodegradable TNT Fluid

## TRIM AND TILT SYSTEM DESCRIPTION

# SYSTEM DESCRIPTION

The power trim/tilt hydraulic system is completely contained between the outboard's stern brackets.

The system consists of:

- Electric motor
- Oil reservoir
- Pump manifold assembly
- Cylinder body assembly

Optimal boat and outboard performance can be achieved by adjusting (trimming) the angle of outboard propeller thrust. The first 15° of outboard movement is considered trim range.

Outboard movement beyond the trim range is considered tilting. Tilting of the outboard may be desired for shallow water drive and for trailering/storage. The tilt cylinder moves the outboard through the tilt range.

**IMPORTANT:** When in tilt range, make sure water is available to gearcase water pickups.

## Manual Adjustment

The outboard can be manually raised or lowered through its entire trim and tilt range by opening the manual release valve a minimum of three turns. When this cycle is complete, the manual release valve must be closed and tightened to a torque of 45 to 55 in. lbs. (5 to 6 N·m) before normal operation can be resumed.

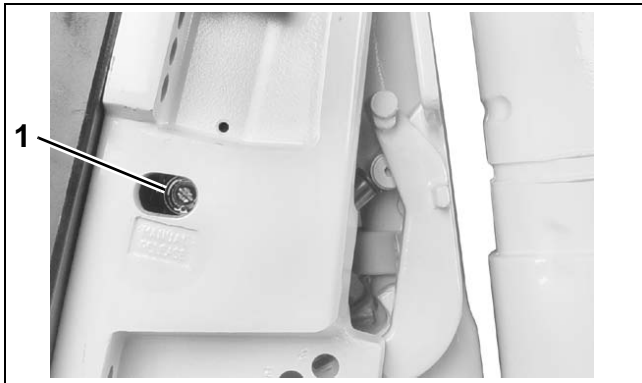

1. Manual release valve, 75-90 HP

001988

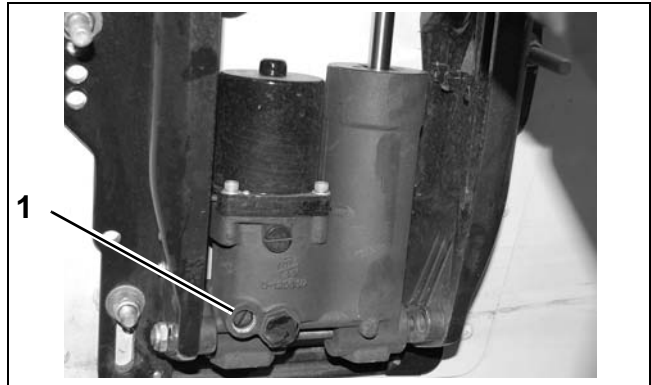

1. Manual release valve, 40-60 HP

008018

## Trailering Bracket And Tilt Support

### 40 – 60 HP MODELS

These outboards are equipped with combination tilt support/trailering brackets.

Tilt the outboard up fully, engage the bracket, then tilt the outboard down until the bracket is firmly in position.

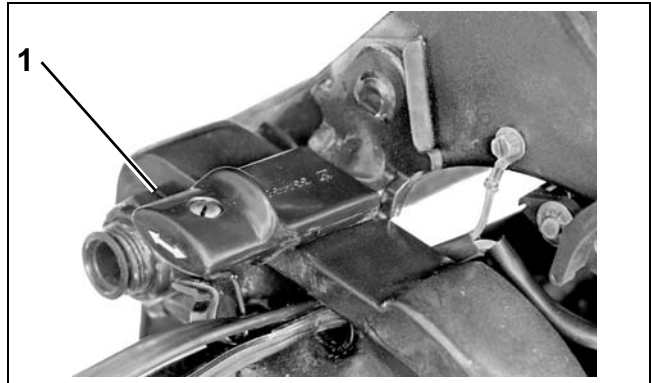

1. Tilt support bracket, 40-60 HP

18954

**75 – 90 HP MODELS**

Use the trawling bracket to support the outboard when trawling in the tilted position. This bracket protects the hydraulic system from damage.

Tilt the outboard up fully, engage the bracket, then tilt the outboard down until the bracket is firmly in position.

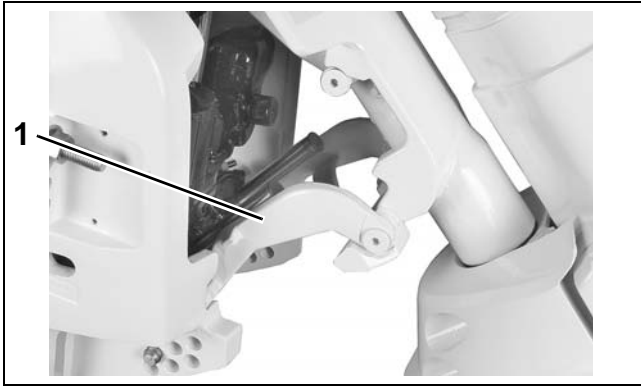

Trawling Bracket

001987

For mooring or storing the boat with the outboard tilted, a tilt support is provided to support the outboard.

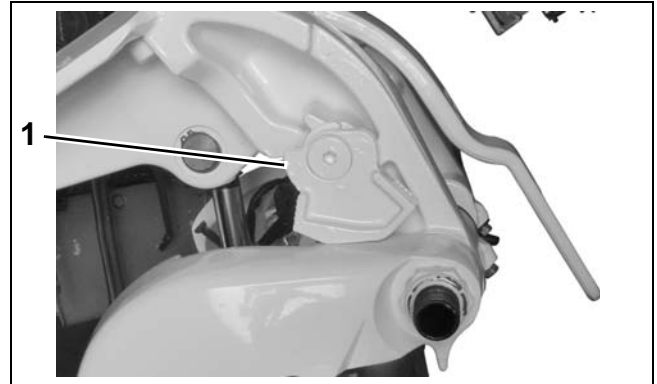

1. Tilt Support

002279

**IMPORTANT:** The tilt support must not be used to support the outboard while trawling.

## ROUTINE INSPECTIONS

### General

Check for external signs of fluid leakage. Correct causes as necessary.

Check the battery to be sure it is in good operating condition.

### Reservoir Fluid

Check reservoir fluid level at least every three years or 300 operating hours. System capacity is approximately:

- **40 - 60 HP:** 15.2 fl. oz. (450 ml)
- **75 - 90 HP:** 21 fl. oz. (620 ml)

**IMPORTANT:** Use only *Evinrude/Johnson* Biodegradable TNT Fluid to fill the hydraulic system.

Refer to **Trim and Tilt** on p. 41 for filling procedure.

### Manual Release Valve

Check the manual release valve with a torque wrench.

**IMPORTANT:** Tighten valve to a torque of 45 to 55 in. lbs. (5 to 6 N·m).

### Stern Brackets

Inspect the stern brackets for binding.

Tighten starboard tilt tube nut to a torque of 45 to 50 ft. lbs. (61 to 68 N·m).

## TROUBLESHOOTING

Use the following guidelines to check a single piston trim/tilt unit that is not working correctly.

### Cylinder Leakdown:

- Manual release valve seals
- External leaks

### No reverse lock:

- External leaks

### No operation, motor runs:

- Manual release valve open
- Fluid level low
- Pump coupler
- Hydraulic pump

### No tilt down:

- Manual release valve
- Fluid level

### Slow performance:

- Manual release valve
- Fluid level low
- Mechanical binding
- Electric motor
- Hydraulic pump

### Unit locked in tilt up:

- Mechanical binding
- Hydraulic pump



# ELECTRICAL CIRCUIT TESTS

## Relay Testing

When the trim-UP button is pressed, the UP relay is energized and connects the blue trim motor wire to the battery positive (+) terminal. The green trim motor wire remains grounded. When the button is released, the blue trim motor wire returns to a grounded position.

When the trim-DOWN button is pressed, the DOWN relay is energized and connects the green trim motor wire to the battery positive (+) terminal. The blue motor wire remains grounded. When the button is released, the green trim motor wire returns to a grounded position.

Refer to **TILT/TRIM RELAY TEST** on p. 106 for relay testing procedure.

## Trim and Tilt Motor Current Draw Tests

Careful analysis of the electric motor's current draw and trim/tilt unit operating speed aids evaluation of the electric motor and certain mechanical components.

Use a battery rated at 360 CCA (50 Ah) or higher that is in good condition and fully charged to perform this test.

**IMPORTANT:** Specifications are for static hydraulic tests. DO NOT attempt to perform the following tests while the boat is moving.

Connect a 0 to 100 A DC ammeter in series between the battery side of the starter solenoid and the red lead to the trim/tilt relay module.

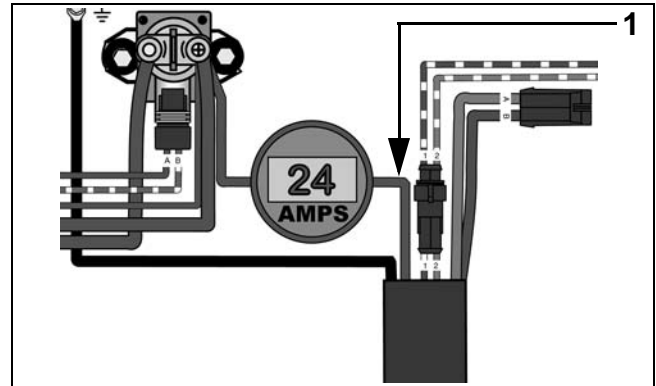

1. Red lead

005441

Observe ammeter and a stopwatch while running hydraulic unit through several complete cycles.

Compare test results to the values listed:

### 75 - 90 HP MODELS

Mode	Normal Current Draw	Time in Seconds
Full Range UP	<30 A	12-18
Full Range DOWN	<30 A	<18
Stall	<40 A	—

### 40 - 60 HP MODELS

Mode	Normal Current Draw	Time in Seconds
Stall UP	11 to 16 Amps	—
Stall DOWN	16 to 22 Amps	—
Full Range UP	—	13 to 19
Full Range DOWN	—	10 to 16

## TRIM AND TILT ELECTRICAL CIRCUIT TESTS

Test results include three basic possibilities:

### A. Low current draw – Check for:

- Valves leaking
- Pump damaged
- O-rings leaking
- Manual release valve damaged

### B. High current draw – Check for:

- Valves sticking
- Pump binding
- Motor binding
- Cylinder binding

### C. Normal current draw, slow operating speed – Check for:

- Manual release valve damaged

## Trim and Tilt Motor No Load Test

**IMPORTANT:** Securely fasten motor in a suitable fixture before proceeding with this test.

Use a battery rated at 360 CCA (50 Ah) or higher that is in good condition and fully charged to perform this test.

Connect a 0 to 25 A ammeter in series with the battery positive (+) terminal, ammeter red lead toward terminal.

Attach or hold a vibration or mechanical tachometer to the motor while performing this test.

Monitor motor RPM and current draw.



30957

The motor shaft must rotate clockwise, as viewed from the pump end, when positive (+) is applied to the blue lead, and negative (–) is connected to green lead.

The motor shaft must rotate counterclockwise, as viewed from the pump end, when positive (+) is applied to the green lead, and negative (–) is applied to the blue lead.

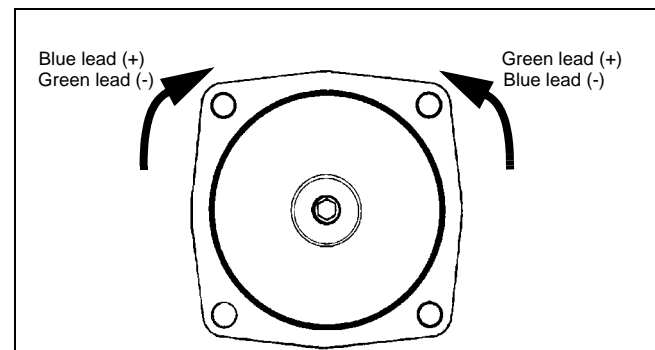

DR4238r

If test results vary, replace the motor.

## Trim Gauge Test

### STEP 1

Turn key switch ON. Using a voltmeter, check for voltage between the trim gauge “I” and “G” terminals.

- If no voltage, check condition of instrument harness, key switch, and engine 20 A fuse.
- If voltage is shown, go to **STEP 2**.

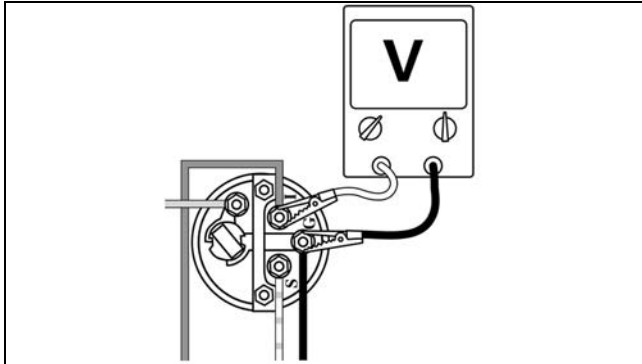

DRC6245

### STEP 2

Remove the white/tan lead from the trim gauge “S” terminal. With key switch ON, gauge should indicate full-trim DOWN position. Now connect a jumper wire between terminals “S” and “G.” Gauge should indicate full-trim UP position.

- If results are different, replace the trim gauge.
- If results agree, refer to **Trim Sender Test**.

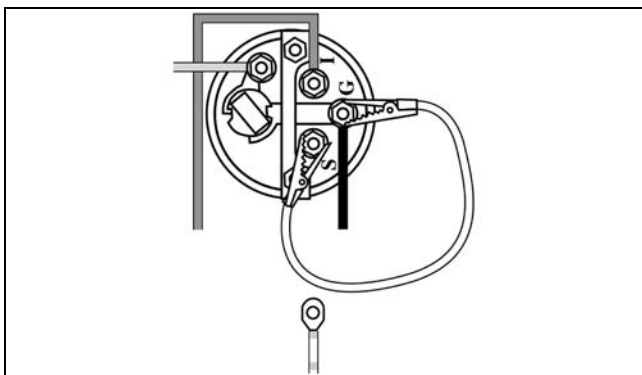

DRC6246A

## Trim Sender Test

**IMPORTANT:** To avoid immediate meter damage, never apply an ohmmeter to an electrical circuit where voltage is present.

Disconnect the 3-pin connector between the instrument harness and engine trim harness. Connect an ohmmeter between the white/tan wire, terminal “C,” of the engine harness and a clean engine ground.

With the outboard fully DOWN, meter must show a reading above 80 ohms.

With the outboard fully UP, meter must show a reading below 10 ohms.

- If results agree, refer to **Trim Gauge Test** on p. 351.
- If results are different, replace trim sender.

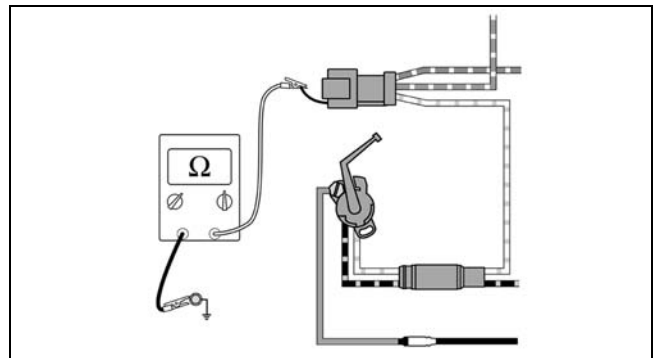

DRC6247

# TRIM AND TILT REPLACEMENT

## Removal

Raise the outboard and engage the tilt support.

Remove the rubber grommet from the blue/green trim/tilt cable connector.

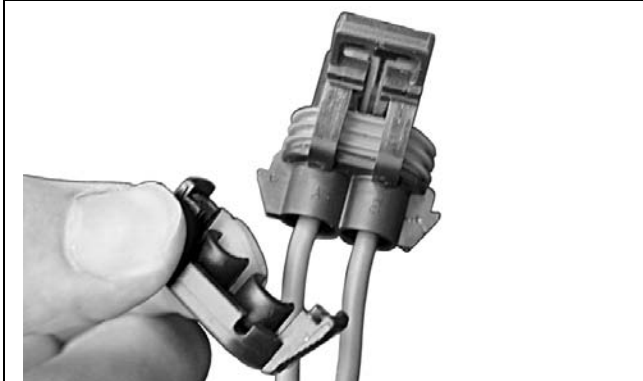

000686

Remove the terminals from the connector by using a suitable tool to depress the tab. While the tab is depressed, pull on the wire from the rear of the connector to release it from the connector.



000687

Separate the trim/tilt unit wires in the braided tube to permit removal through the hole in the stern bracket.

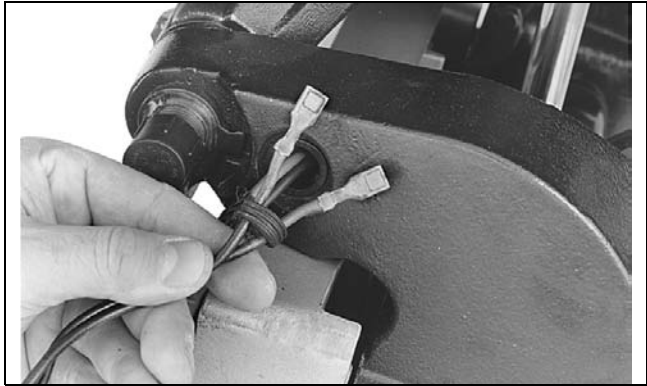

25078

## 40 – 60 HP MODELS

Remove the spring clip from the cylinder pin.



15493

Thread Adapter, P/N 340624, onto Slide Hammer, P/N 391008. Screw the adapter into the cylinder pin and remove the pin.

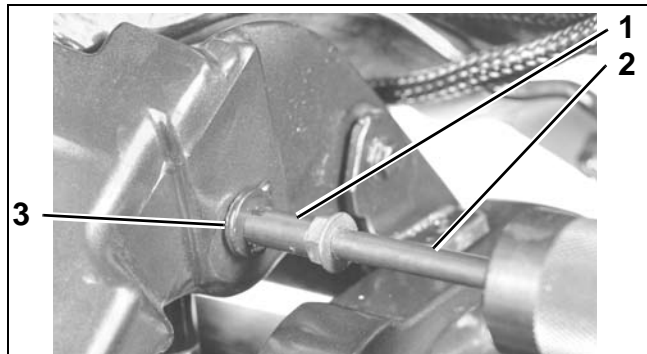

1. Thread adapter
2. Slide hammer
3. Cylinder pin

39434

## TRIM AND TILT TRIM AND TILT REPLACEMENT

Remove one of the locknuts from the angle adjustment rod. Remove the rod from the stern brackets.



18941

Remove the unit from the stern brackets far enough to remove the ground lead from the pump motor mounting screw.

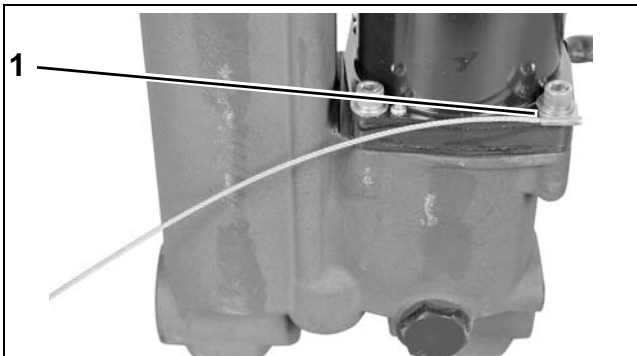

1. Ground lead

007640

### 75 – 90 HP MODELS

Remove the external snap rings from the upper pin.

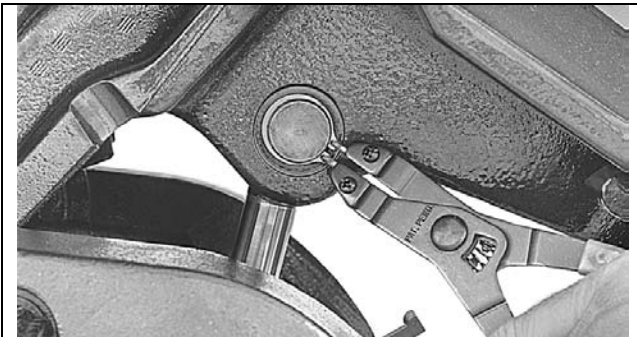

25064

Use a punch to remove the upper pin.



25065

Retract the tilt cylinder rod.

Remove the external snap rings from the lower pin.

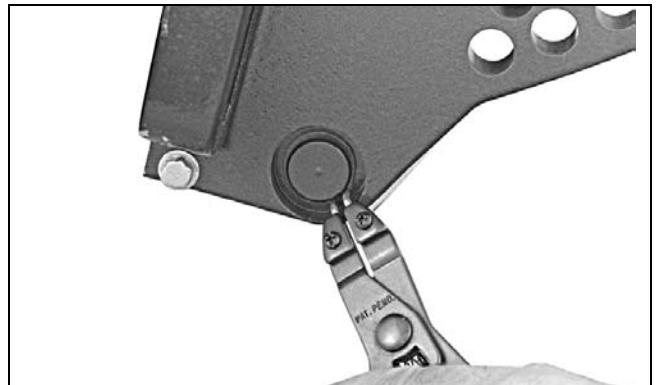

25077

Use a punch to remove the lower pin and remove the trim/tilt unit from the stern brackets.

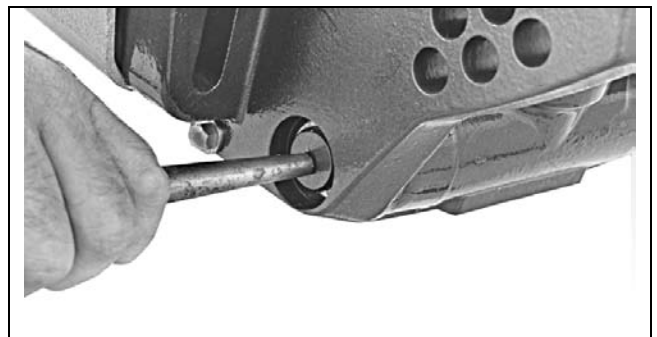

25076

## TRIM AND TILT

### TRIM AND TILT REPLACEMENT

Remove the unit from the stern brackets far enough to remove the ground lead from the pump motor mounting screw.

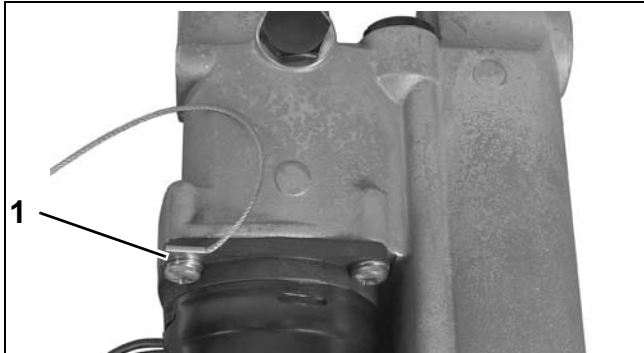

1. Ground lead

002527

Lubricate the angle adjustment rod with *Triple-Guard* grease. Install the rod. Tighten the locknuts to a torque of 20 to 25 ft. lbs. (27 to 34 N-m).



18941

## Installation

### 40 – 60 HP MODELS

Lubricate the cylinder and thrust rod bushings with *Triple-Guard* grease. Install the bushings.



15591

Install the ground lead.

Place trim/tilt unit into position.

Loosen the manual release valve if necessary and extend tilt cylinder rod to match with holes in swivel bracket.

Apply *Triple-Guard* grease to upper pin and install the pin.

Secure the cylinder pin with cotter clip.

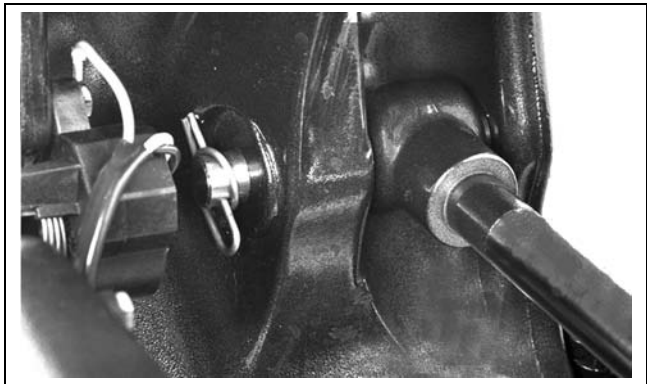

15493

**75 – 90 HP MODELS**

Install the ground lead.

Place trim/tilt unit into position. Apply *Triple-Guard* grease to the lower pin and install the pin.

Install external snap rings on lower pin with sharp edge of ring facing out.

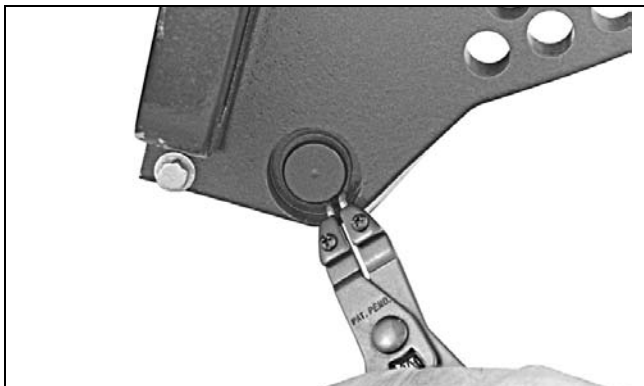

25077

Loosen the manual release valve if necessary and extend tilt cylinder rod to match with holes in swivel bracket.

Apply *Triple-Guard* grease to upper pin and install the pin.

Install external snap rings onto upper pin with sharp edge facing out.

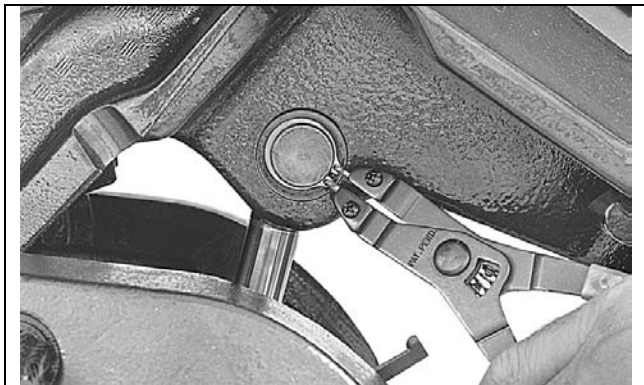

25064

**ALL MODELS**

Place trim/tilt wires in braided tube and install through hole in the stern bracket.

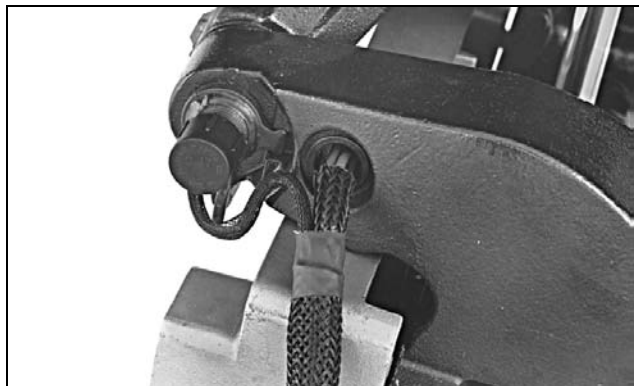

25079

Install connector on trim/tilt cable and reconnect trim connectors to engine wire harness.

Release the tilt support and lower the outboard. Tighten the manual release valve to a torque of 45 to 55 in. lbs. (5 to 6 N·m).

## TRIM AND TILT SERVICE

### Disassembly

Thoroughly clean the unit before disassembling. Scrub all outside surfaces with a stiff brush and hot, soapy water to prevent surface dirt from contaminating internal parts.

Always use a lint free shop cloth when handling power trim/tilt components.

If painting the unit is required, paint it after it is completely assembled. Painting of individual components may cause flakes of paint to enter the hydraulic passages during assembly. Tape the trim/tilt piston rods before painting.

**⚠ WARNING**

**There may be high pressure behind some power trim valves. To avoid injury when removing manual release valve, be sure to cover valve with a shop cloth until the pressure is released. Wear safety glasses.**

**IMPORTANT:** Before removing manual release valve, relieve pressure by fully extending cylinder.

Screw the manual release valve in. Remove the retaining ring using a small pick or screwdriver. Discard the retaining ring.

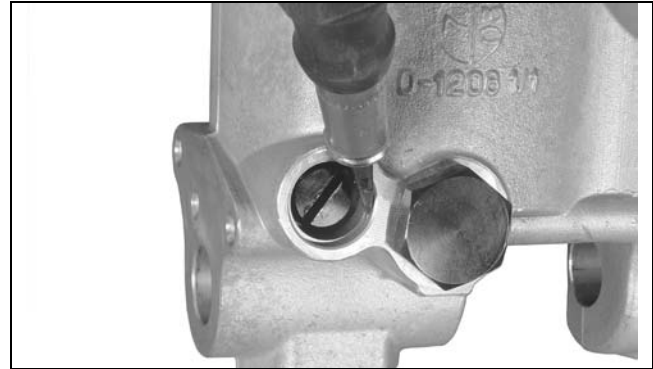

40 - 60 HP Models

002528

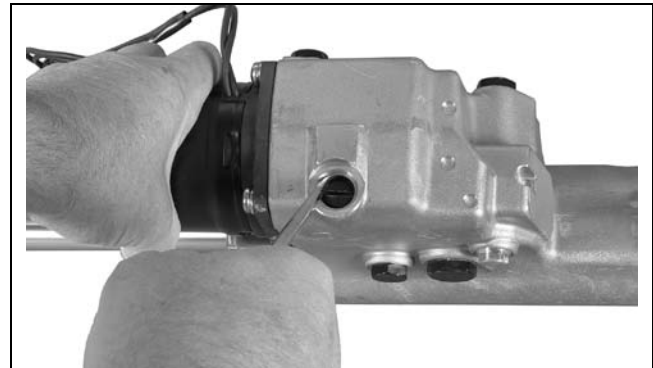

75 - 90 HP Models

004279



Slowly remove the manual release valve. There may be pressure behind the valve—wear safety glasses.

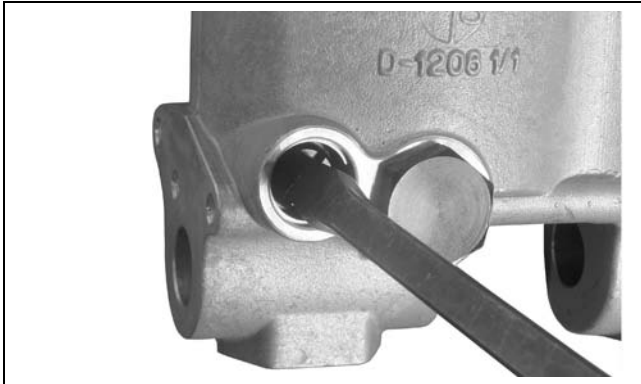

40 - 60 HP Models

002529

Remove the four large motor flange retaining screws. Remove the motor and discard O-ring, screws, and washers.

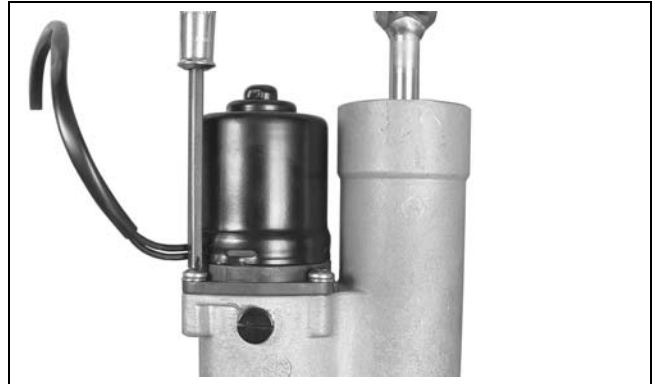

40 - 60 HP Models

002531

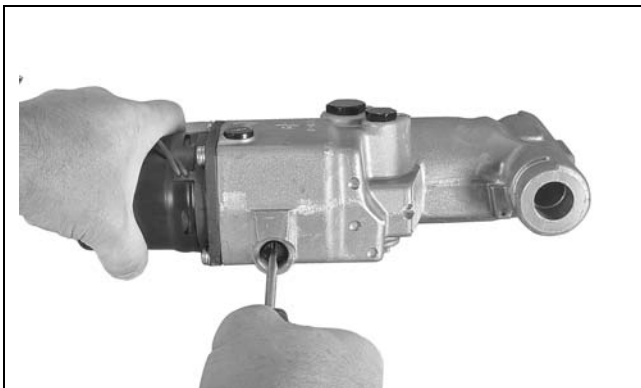

75 - 90 HP Models

004285



75 - 90 HP Models

004282

Inspect the manual release valve. Discard the O-rings on the housing.



007108

Remove drive coupler from either the motor or the pump assembly.



002532

# TRIM AND TILT

## TRIM AND TILT SERVICE

### Assembly

**IMPORTANT:** Use only *Evinrude/Johnson Bio-degradable TNT Fluid* to fill the hydraulic system.

Install drive coupler in pump assembly.

Install a new motor O-ring.



002533

Position the motor on the manifold and install four **new** screws and lock washers. Tighten the screws 35 to 50 in. lbs. (4 to 5.6 N-m).

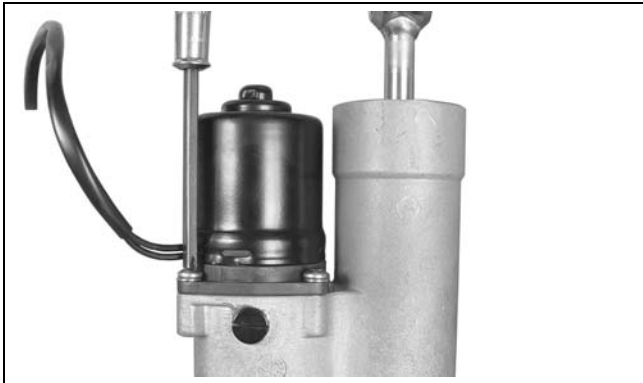

40 - 60 HP Models

002531



75 - 90 HP Models

004282

Oil O-rings and install them on the manual release valve. Oil and install the manual release valve. Tighten the valve to a torque of 45 to 55 in. lbs. (5 to 6 N-m).

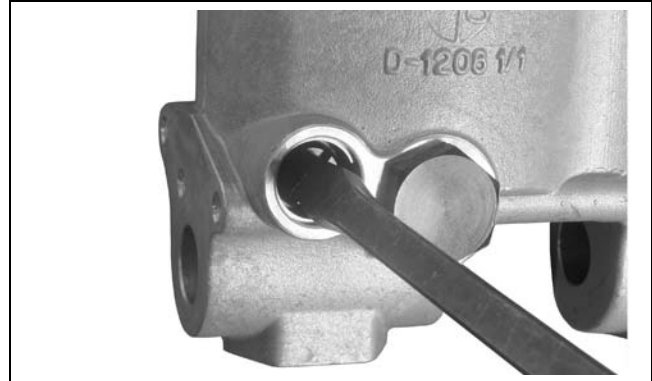

40 - 60 HP Models

002529

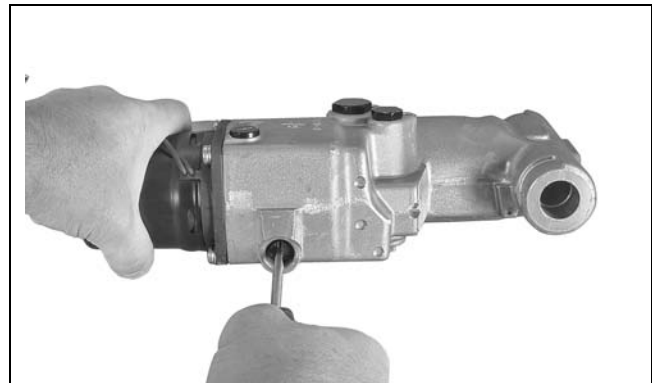

75 - 90 HP Models

004285

Install **new** retaining ring in groove.

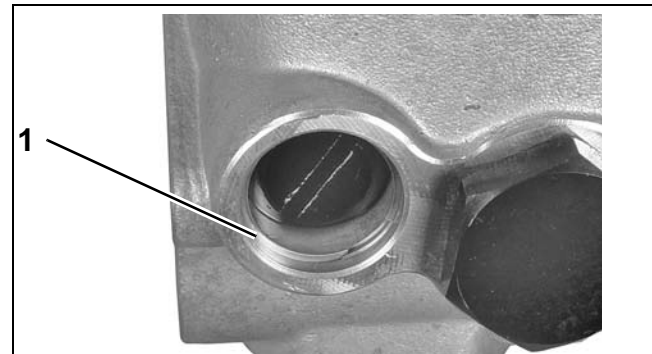

1. Retaining ring

002534

Fill the oil reservoir up to the fill plug with *Evinrude/Johnson* Biodegradable TNT Fluid. Install the fill plug.

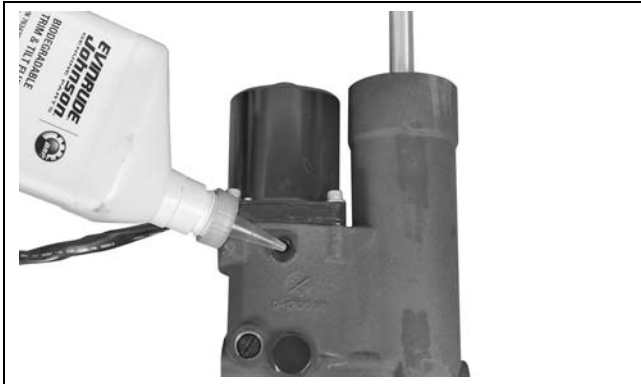

40 - 60 HP Models

007646

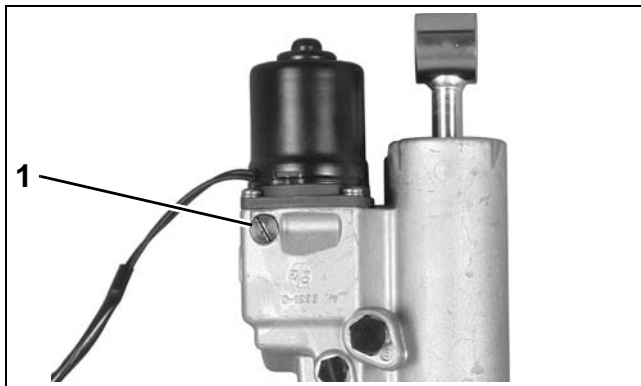

75 - 90 HP Models

004278

Run the motor, then recheck oil level. Cycle the unit several times and check the oil level when the cylinder is fully extended. Oil should be level with bottom of fill port. Install and tighten the fill plug to a torque of 45 to 55 in. lbs. (5 to 6 N·m).



# MANUAL STARTER

## TABLE OF CONTENTS

SERVICE CHART .....	362
RECOIL STARTER REMOVAL .....	363
RECOIL STARTER DISASSEMBLY .....	363
RECOIL STARTER CLEANING AND INSPECTION .....	365
RECOIL STARTER ASSEMBLY .....	365
RECOIL STARTER INSTALLATION .....	369

# SERVICE CHART

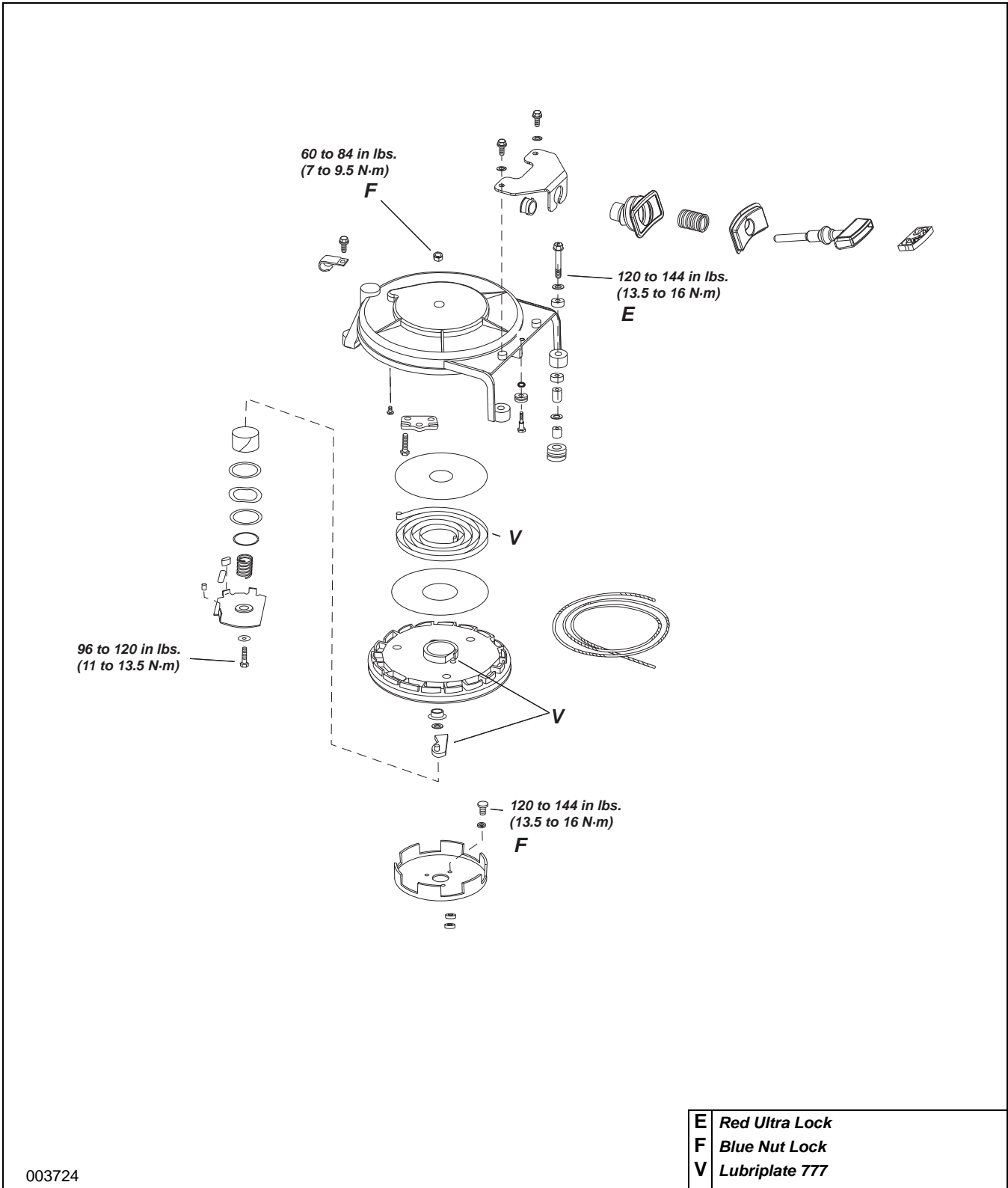

003724

## RECOIL STARTER REMOVAL

### WARNING

To prevent accidental starting while servicing, twist and remove all spark plug leads.

Remove the clamp holding the oiling system wiring harness.

Remove the three starter housing screws and washers.

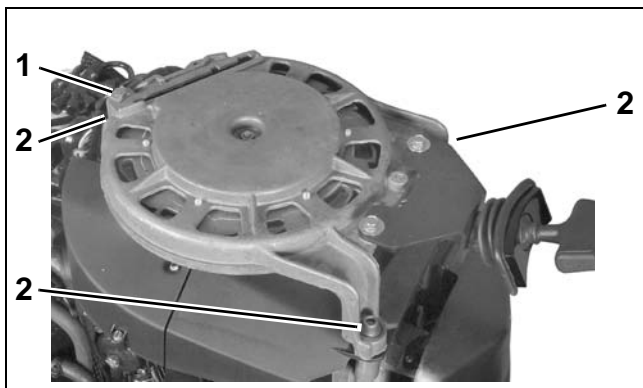

1. Clamp  
2. Starter housing screws (3) 002515

Lift starter housing from outboard.

Remove three screws and remove starter ratchet from flywheel.

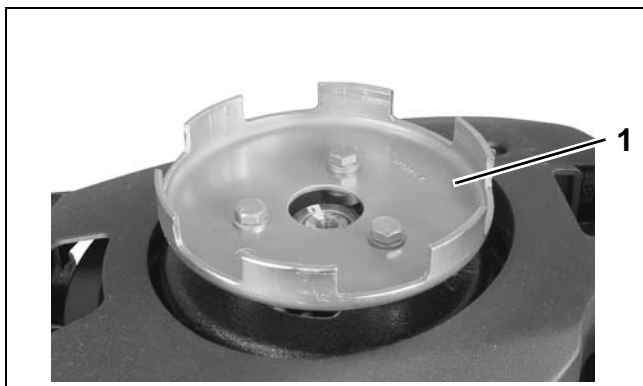

1. Ratchet 006483

## RECOIL STARTER DISASSEMBLY

### WARNING

Wear safety glasses while disassembling and assembling manual starters because of rewind spring tension.

Pull the starter rope out far enough to tie a slip knot in the rope. Remove the end of the starter rope from the handle anchor and remove the handle. Release the slip knot and ease the rope back in until the rewind spring is fully unwound. If necessary, remove the starter handle bracket from the starter housing.



1. Slip knot  
2. Rope anchor 007853

Remove the rope guide and pulley support from the starter housing.

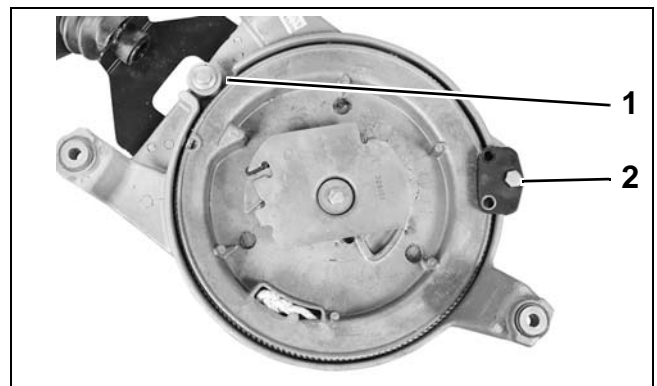

1. Rope guide  
2. Pulley support 007854

# MANUAL STARTER

## RECOIL STARTER DISASSEMBLY

Remove the nut from the starter pawl retaining screw.

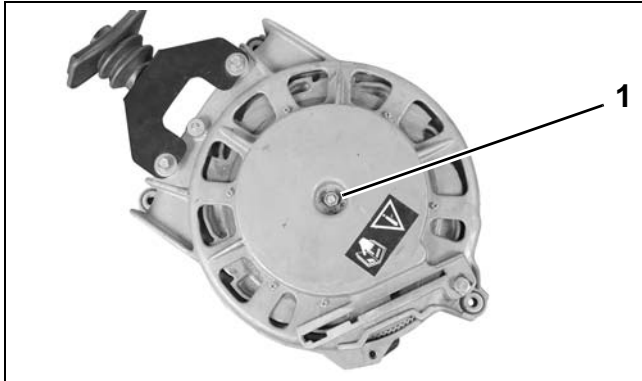

1. Nut 007855

Remove the starter pawl retaining screw, washer, and starter pawl plate with plate return spring from the starter assembly.

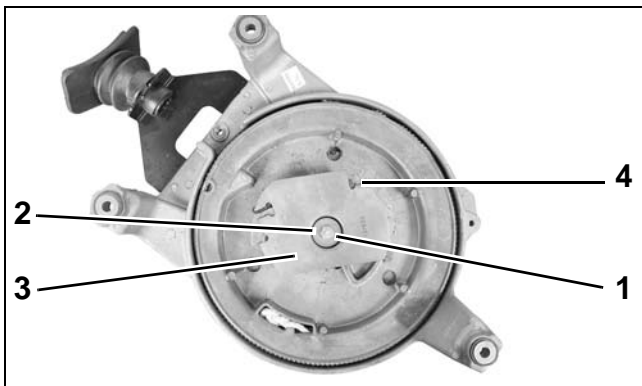

1. Screw  
2. Washer  
3. Plate  
4. Spring 007856

Remove starter housing spring and starter pawl with spring washer from the starter assembly.

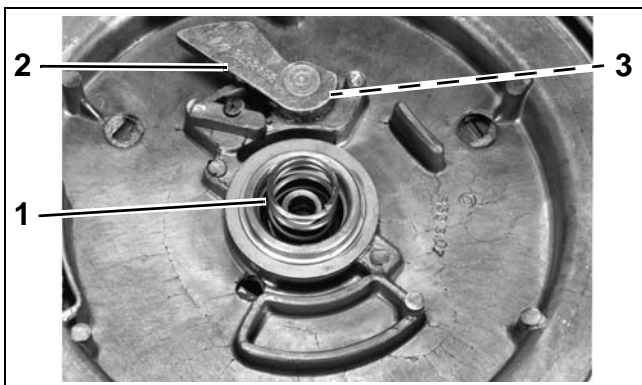

1. Spring  
2. Starter pawl  
3. Spring washer (under starter pawl) 34855

Use a screwdriver to pry open the pulley lock ring, and remove ring from the starter.

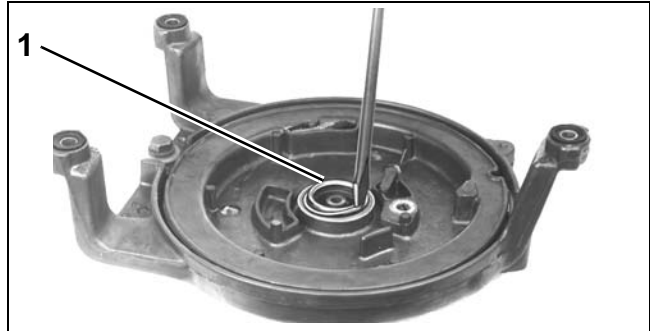

1. Lock ring COA1368

Remove the friction plates and friction plate spring washer.

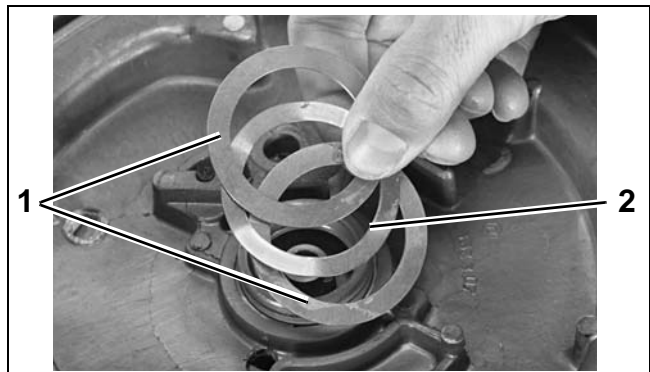

1. Friction plates  
2. Friction plate spring washer 34854

Hold the pulley in the starter housing while turning the starter over, legs down. Hold fingers clear of the pulley and jar the starter housing against a bench to dislodge the rewind spring and pulley. Remove the pulley bushing from the pulley.



007857



## RECOIL STARTER CLEANING AND INSPECTION

Wash metal components in solvent and dry with compressed air.

Inspect the rewind spring for broken end loops and weak tension.

Examine the starter pawl for wear.

Inspect the starter components for wear. Replace as necessary.

Inspect starter rope. Replace rope if frayed. Cut new rope 96.5 in. (245 cm) in length. Fuse ends of rope to a length of 1/2 in. (12 mm).

Examine the pulley and the starter housing. Look for sharp edges and rough surfaces that could fray the starter rope. File and polish to remove.

Examine the starter and starter lockout parts. Replace any worn or damaged parts.

## RECOIL STARTER ASSEMBLY

### WARNING

**Wear safety glasses while disassembling and assembling manual starters because of rewind spring tension.**

Place starter spring shield and pulley bushing into the starter housing.



1. Shield

COA1360

Clamp base of Starter Spring Winder and Installer, P/N 392093, in a vise. Insert release plate into spring winder base.

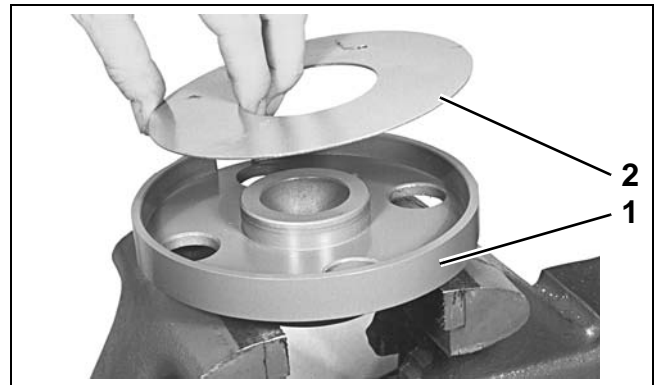

1. Base  
2. Plate

CO3593

## MANUAL STARTER RECOIL STARTER ASSEMBLY

Apply *Triple-Guard* grease or *Lubriplate 777* to the rewind spring. Install the rewind spring into the spring winder base with open loop of spring facing inward. Insert the pin of the crank and pin assembly into the loop of the rewind spring. Secure the crank and pin assembly to the starter winder base with the crank retainer screw.

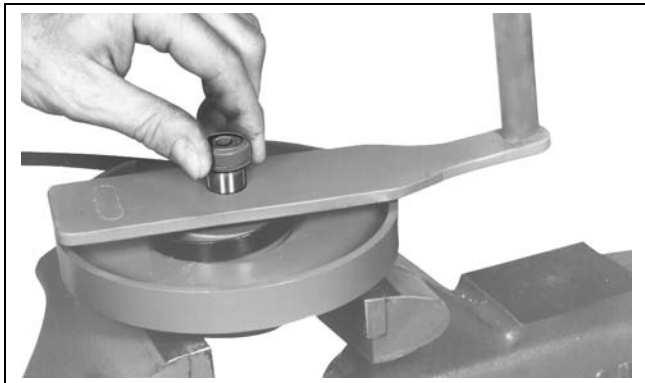

CO3591

Rotate the crank and pin assembly in the direction shown on the tool. Wind the spring into the starter winder base until end of spring contacts the starter winder base.

Remove the crank retainer screw and the crank and pin assembly from the starter winder base. Remove the starter winder base from the vise.



CO3589

Install the rewind spring into the starter housing. Locate the outer loop of the rewind spring on the pin in the starter housing. Press down through the holes in the spring winder base to transfer the rewind spring into the starter housing.

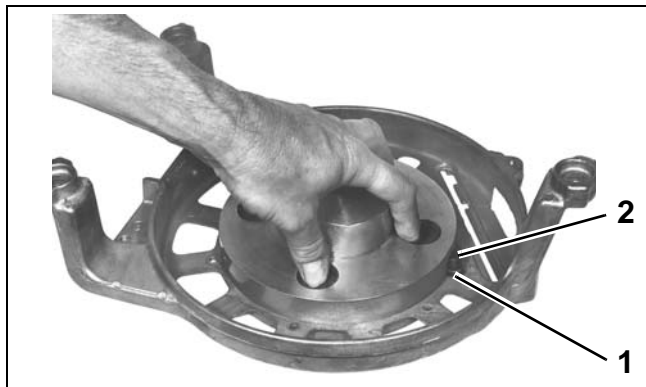

1. Outer loop
2. Pin

CO3584

Apply *Triple-Guard* grease or *Lubriplate 777* to the pulley bushing. Install the pulley bushing in the pulley. Place the pulley shim on the pulley.

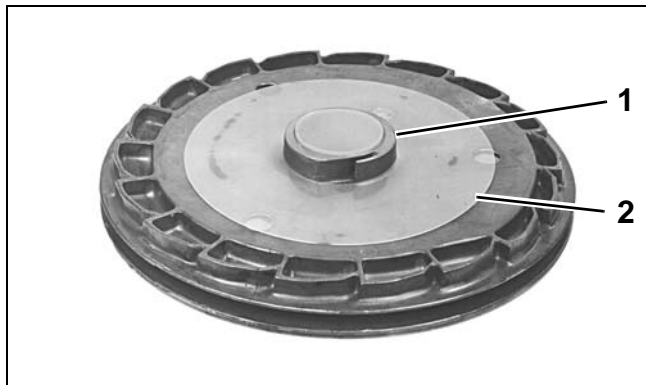

1. Bushing
2. Shim

COA1364

Bend the inside loop of the rewind spring in toward the center of the starter housing. Place the

## MANUAL STARTER RECOIL STARTER ASSEMBLY

inner loop of the spring in the slot of the pulley, and install the pulley in the starter housing.

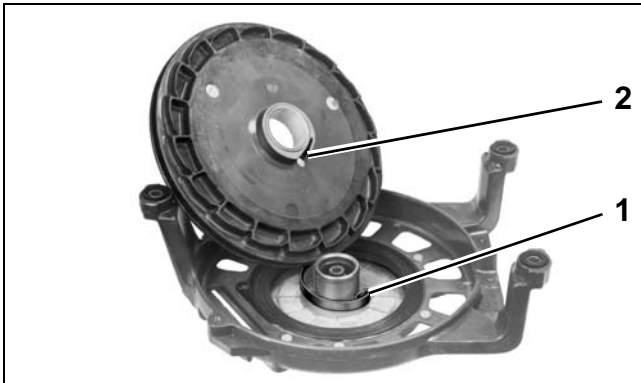

1. Inside loop
2. Slot

COA1365

Place the starter housing spring in the starter housing.

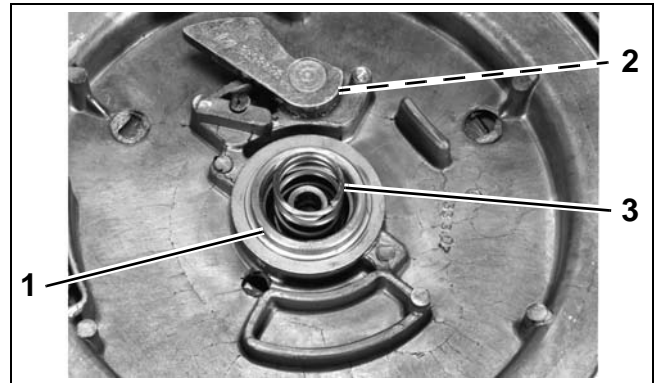

1. Lock ring
2. Spring washer (under starter pawl)
3. Spring

COA1361

Place the friction plate spring washer between the two friction plates on the pulley hub. Secure the friction plate and friction plate spring washer with the pulley lock ring.

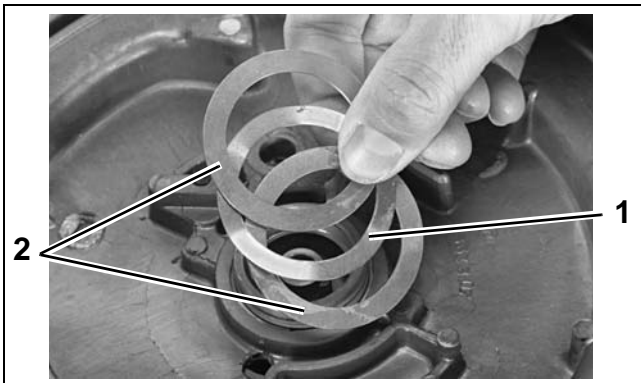

1. Friction plate spring washer
2. Friction plates

34854

Install the starter pawl plate return spring on the starter pawl plate. Press the other end of spring on the boss of the pulley. Position the starter pawl plate on the pulley.

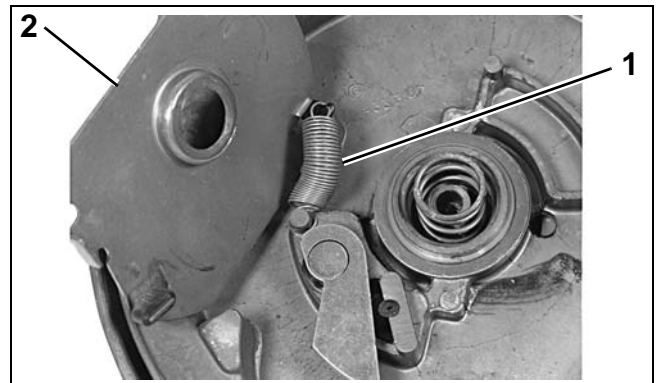

1. Spring
2. Plate

46767

Make sure the starter pawl bushing is installed in the pulley. Apply *Triple-Guard* grease or *Lubriplate 777* to boss of the starter pawl. Place spring washer on the boss of the starter pawl. Place the starter pawl in the pulley.

Clean threads of the starter pawl plate retaining screw and nut to remove adhesive.

## MANUAL STARTER RECOIL STARTER ASSEMBLY

Install the starter pawl plate retaining screw and washer into the starter housing. Tighten screw to a torque of 96 to 120 in. lbs. (11 to 13.5 N·m).

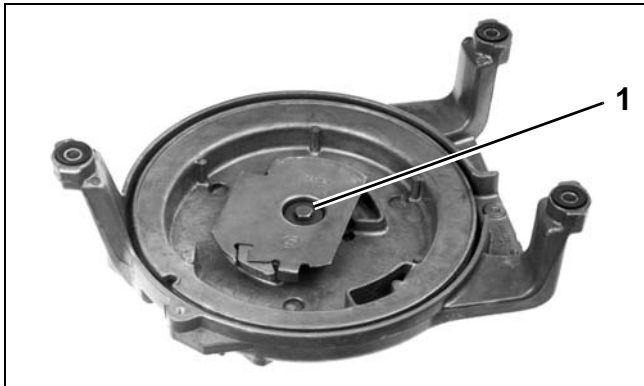

1. Screw

COA1375

Spray threads of starter pawl plate retaining screw and nut with *Locquic Primer*. Apply *Nut Lock* to the threads of the nut. Install and tighten the nut securely.

Install the rope guide and pulley support to the starter housing. Tighten the screws securely.

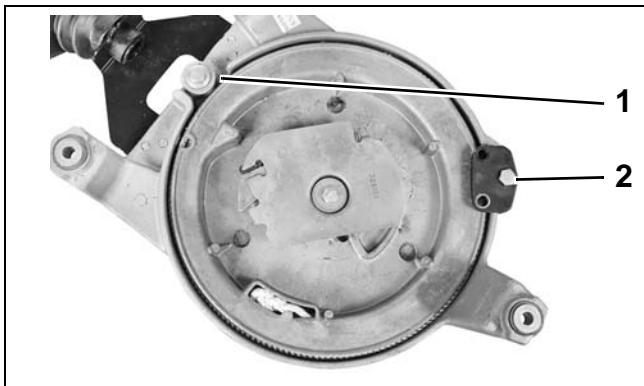

1. Rope guide  
2. Pulley support

007854

If removed, install the starter handle bracket to the starter housing. Tighten screws securely.

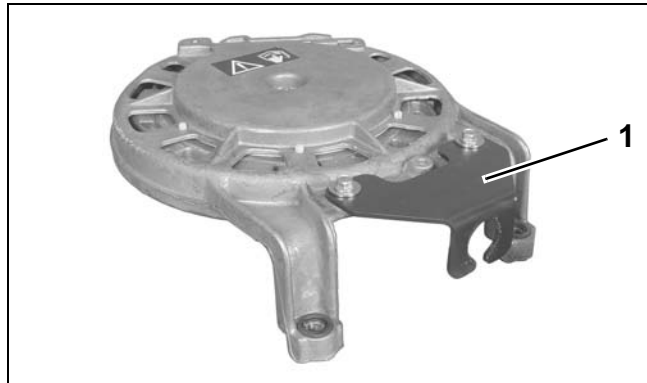

1. Starter handle bracket

002517

Tie a knot in one end of the starter rope. With the starter housing upside down on a bench, wind the pulley counterclockwise until the rewind spring is tight.

Back off the rewind spring until the rope cavity of the pulley is aligned with the rope guide. Thread the starter rope through the pulley, rope guide, and outlet in the starter handle bracket.

Seat the knotted end of the starter rope in the pulley. Tie a slip knot in the starter rope to hold rope in position.

Apply *Triple-Guard* grease or *Lubriplate 777* to the handle end of the starter rope. Using Starter Rope Threading Tool, P/N 378774, thread the starter rope through the handle.

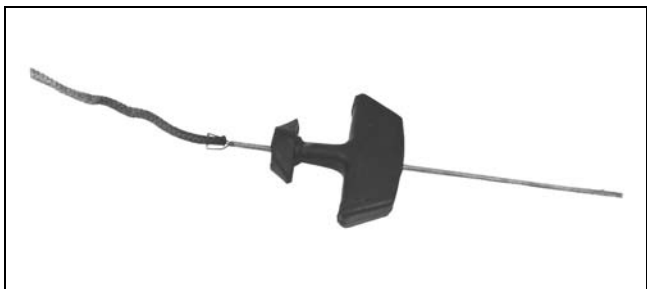

COA1373

Press the starter rope into the channel of the rope anchor, with end of starter rope firmly against end of channel. Press the anchor into the handle.

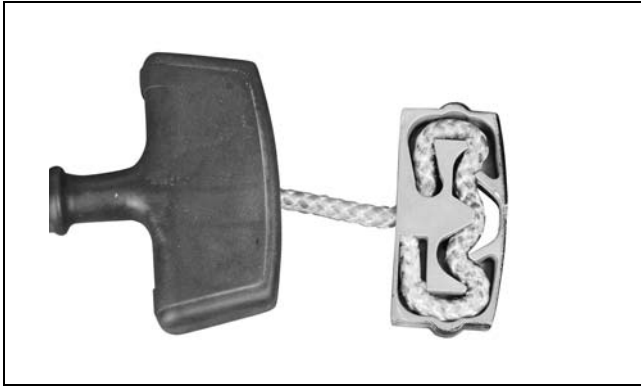

007858

Check operation of the starter pawl when the starter rope is pulled out. The starter pawl should extend when the starter rope is pulled and retract when the starter rope recoils.

## RECOIL STARTER INSTALLATION

Apply *Nut Lock* to the threads of starter ratchet screws. Install washers and ratchet on flywheel. Tighten screws to a torque of 120 to 144 in. lbs. (13.5 to 16 N-m).

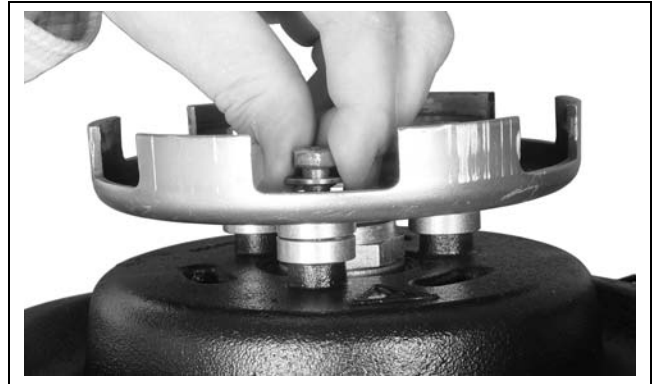

006654

Place the starter assembly onto the outboard. Install the starter housing retaining screws, washers, and lock washers. Be sure to place washers between the starter housing and the flywheel cover. Apply *Ultra Lock* to threads and tighten the three starter housing screws to a torque of 120 to 144 in. lbs. (14 to 16 N-m).

Install clamp for oiling system wiring harness.

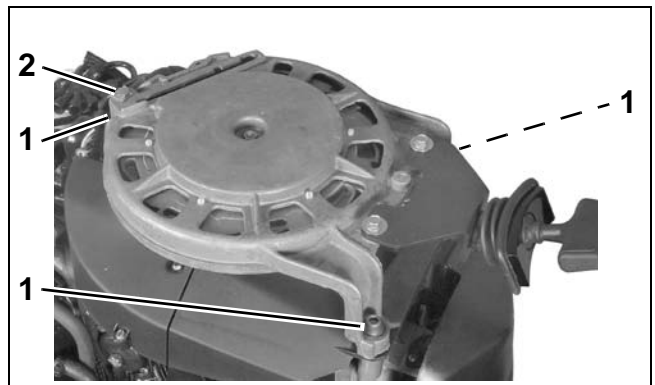

1. Starter housing screws (3)
2. Clamp

002515



# SAFETY

## TABLE OF CONTENTS

<b>MARINE PRODUCTS AND THE SAFETY OF PEOPLE WHO USE THEM</b> .....	<b>S-3</b>
OUTBOARD SHIFT SYSTEMS AND SAFETY .....	<b>S-4</b>
OUTBOARD SPEED CONTROL SYSTEM AND SAFETY .....	<b>S-5</b>
OUTBOARD STEERING CONTROL SYSTEM AND SAFETY .....	<b>S-6</b>
OUTBOARD FUEL, ELECTRICAL SYSTEM, AND SAFETY .....	<b>S-8</b>
OUTBOARD MOUNTING SYSTEM AND SAFETY .....	<b>S-11</b>
OUTBOARD HYDRAULIC TILT/TRIM SHOCK ABSORPTION SYSTEM AND SAFETY .....	<b>S-13</b>
OUTBOARD EMERGENCY STOP SYSTEM AND SAFETY .....	<b>S-14</b>
SUMMING UP .....	<b>S-16</b>
<b>MARINE PRODUCTS AND THE SAFETY OF PEOPLE WHO FIX THEM</b> .....	<b>S-17</b>
HANDLING OUTBOARDS .....	<b>S-17</b>
HANDLING LEAD/ACID BATTERIES .....	<b>S-21</b>
GASOLINE – HANDLE WITH CARE .....	<b>S-22</b>
HAZARDOUS PRODUCTS .....	<b>S-23</b>
SAFETY AWARENESS TEST .....	<b>S-24</b>





# MARINE PRODUCTS AND THE SAFETY OF PEOPLE WHO USE THEM

## WARNING

This Safety section contains information relevant to the safety of boaters and people that service boats. Please read this section carefully and share it with all shop technicians. Always follow common shop safety practices. If you have not had training related to common shop safety practices, you should do so not only to protect yourself, but also to protect the people around you.

It is impossible for this manual to cover every potentially hazardous situation you may encounter. However, your understanding and adherence to the recommendations contained in this manual and use of good judgment when servicing outboards will help promote safety. Always be alert and careful: a good foundation for safety.

Enjoyable boating is the goal of people who design and build marine products. To reach this goal, manufacturers are careful to make sure:

- Product user is informed; and
- Products are safe and reliable.

It is up to you, the people who...

- Rig boats;
- Fix machinery; and
- Maintain equipment

...to keep the products safe **and** reliable.

This section talks about safe boating and how you can help make it safe. Some of these safety issues you will know, others you may not.

### First!

A word about parts... Plain parts; special parts; all parts!

### DO NOT SUBSTITUTE PARTS

“They look the same, but are they the same?”

- Same size?
- Same strength?
- Same material?
- Same type?

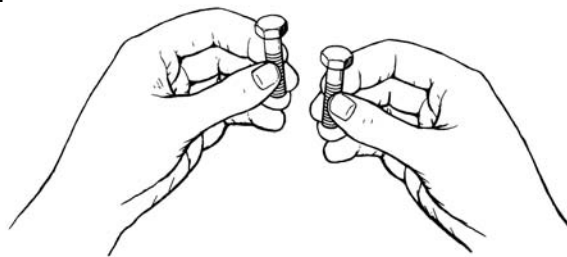

Don't substitute unless **you know** they are the **same** in **all** characteristics.

### Second!

- Special locking bolts and nuts are often used to hold steering, shift, and throttle remote control cables to the outboard.
- When you take any outboard off a boat, keep track of special nuts and bolts. Do not mix with other parts. Store them on the outboard, then they are there when you need them.
- When the outboard is returned to the boat, use only the special nuts and bolts to hold remote steering, shift, and throttle cables to the outboard.

## Outboard Shift Systems and Safety

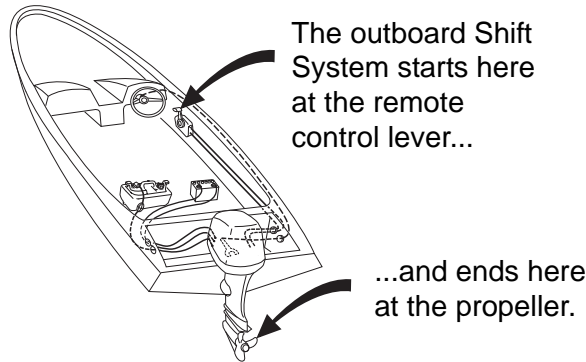

### What is most important?

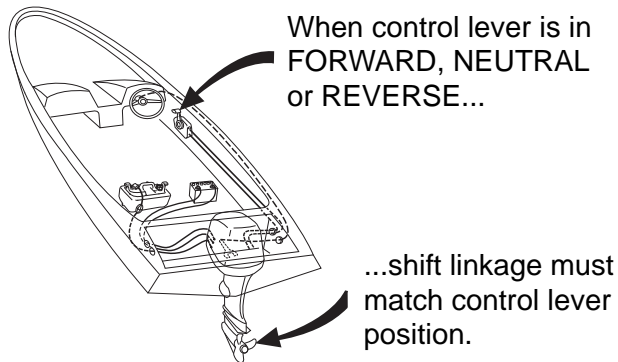

### What could happen?

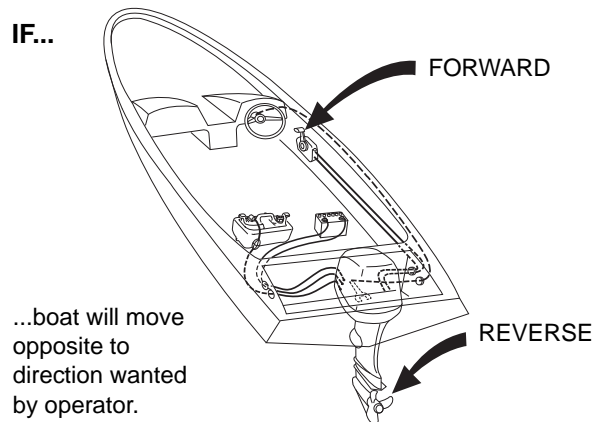
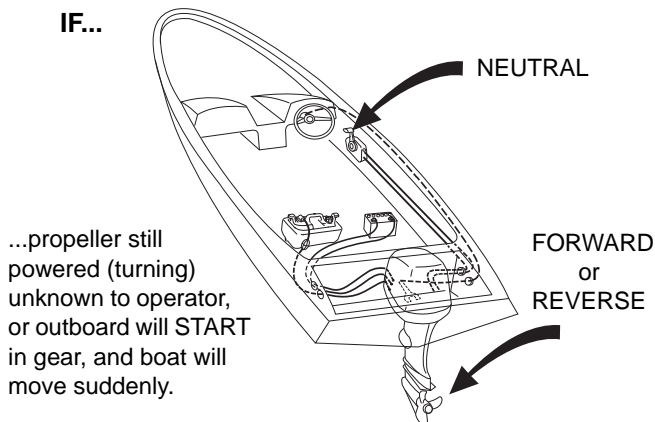

### How can loss of shift control be minimized?

**When rigging or after servicing**

**Read, understand, and follow manufacturer's instructions**

- Follow warnings marked "⚠" closely.
- Assemble parts carefully.
- Make adjustments carefully.
- Test your work. Do not guess. Make sure propeller does just what the operator wants and nothing else.
- Do not shift gears on a stopped outboard. Adjustments can be lost and parts weakened.

## Outboard Speed Control System and Safety

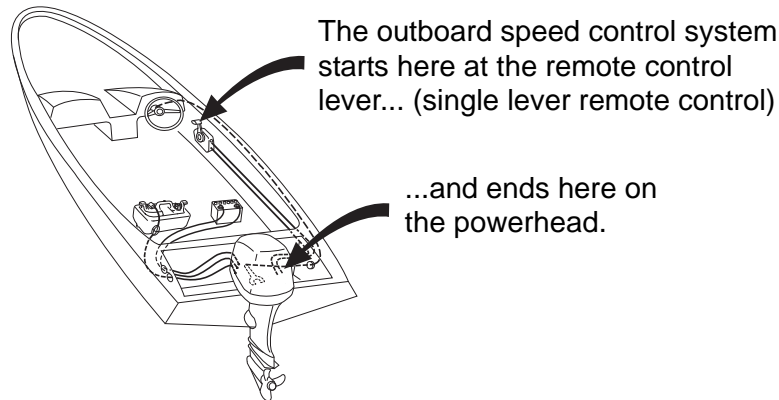

### What is most important?

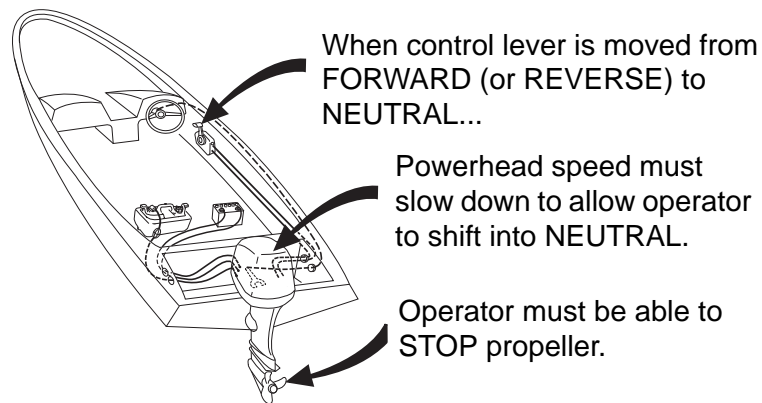

### What could happen?

If Operator cannot slow down the outboard or shift into NEUTRAL gear (stop propeller), Operator could panic and lose control of boat.

### How can loss of speed control be minimized?

#### When rigging or after servicing

#### Read, understand, and follow manufacturer's instructions

- Follow warnings marked "⚠" closely.
- Assemble parts carefully.
- Make adjustments carefully.
- Test your work. Do not guess. Make sure speed control system does just what the operator wants and nothing else.
- Make sure full throttle can be obtained so Operator will not overload parts.

## Outboard Steering Control System and Safety

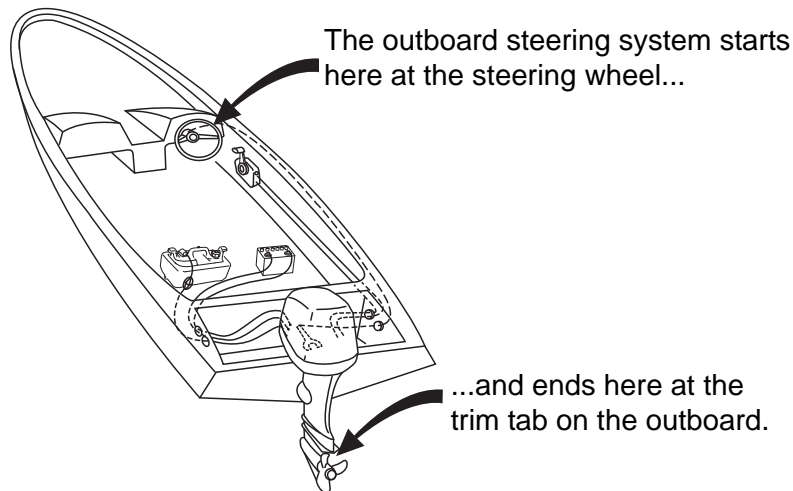

### What is most important?

The steering system:

- Must not come apart;
- Must not jam; and
- Must not be sloppy or loose.

### What could happen?

- If steering system comes apart, boat might turn suddenly and circle. Persons thrown into the water could be hit.

- If steering jams, operator may not be able to avoid obstacles. Operator could panic.
- If steering is loose, boat may weave while operator tries to steer a straight course. With some rigs (at high speed), loose steering could lead to loss of boat control.

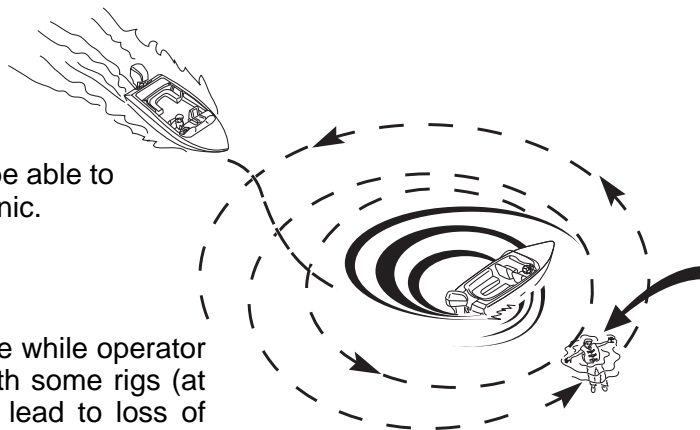

### How can loss of steering control be minimized?

#### When rigging or after servicing

- Use a steering system recommended by the outboard manufacturer which meets Marine Industry Safety Standards (ABYC).
- **Read, understand, and follow** manufacturer's **instructions**
- Follow warnings marked "⚠" closely.
- Assemble parts carefully.
- Make adjustments carefully.
- Keep parts moving freely. Lubricate parts as shown in manual.
- Use the bolts, nuts and washers supplied with steering attachment kits—they are a special locking type that will not loosen, rust, or weaken.

### Transom Mounted Steering Systems – Check to Uncover Possible Trouble!

Tilt outboard into boat, then turn it.

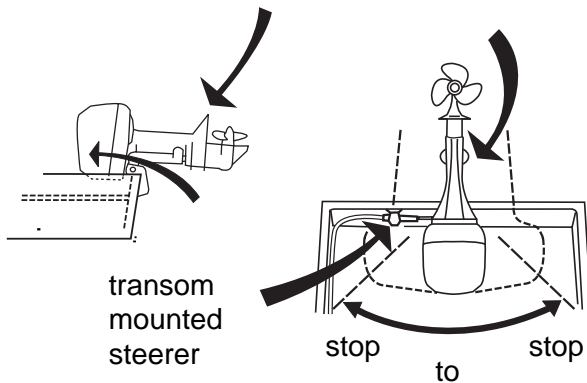

During this procedure, steering parts:

- Must not bind; and
- Must not touch other boat, outboard, or accessory parts in transom area.

**Why?** A hard blow to the outboard's gearcase can result in damage to steering parts.

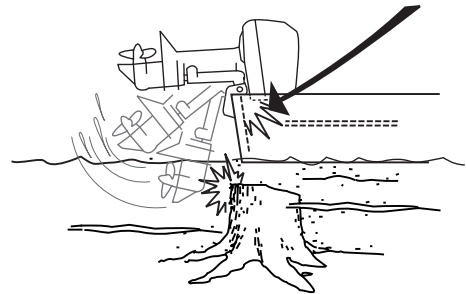

Be aware that raising or lowering outboard on transom can change a set-up which was OK earlier. If moved up or down even one-half inch, run test again to make sure steering parts are free and clear.

Check for damaged parts. Blows to the outboard like this

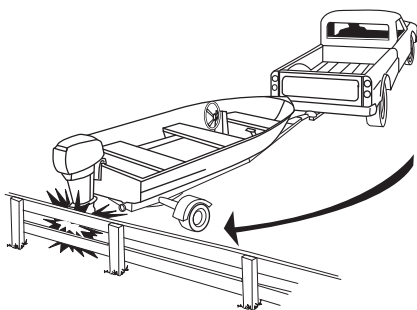

or this can put heavy loads on steering parts. Look for:

- Cracked parts, including steering parts, swivel brackets, and transom brackets;
- Bent parts; and
- Loose nuts and bolts.

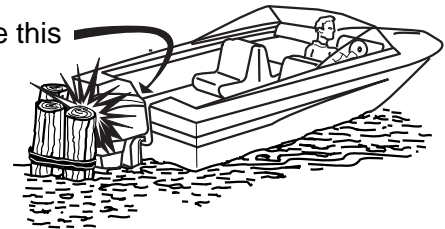

**Replace damaged parts. If weakened, parts could fail later on the water when least expected.**

## Outboard Fuel, Electrical System, and Safety

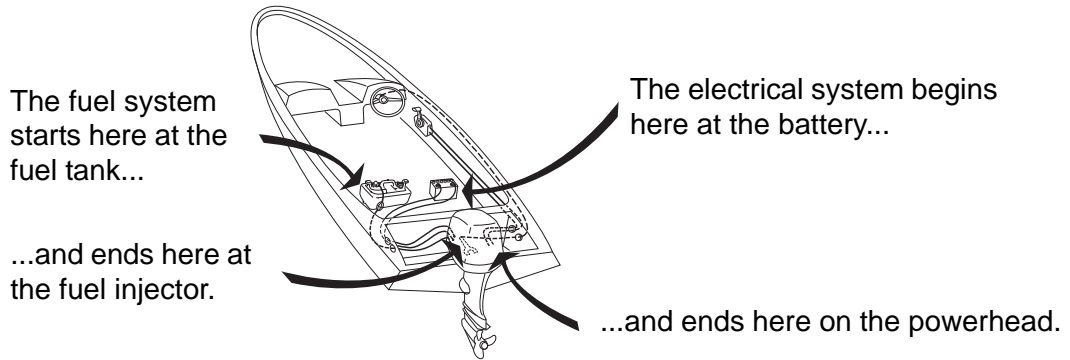

### What is most important?

- Fuel leakage must be eliminated.
- Stray electric sparks must be avoided.

### What could happen?

- **When not boating**, fuel leaking in car trunk or van, or place where portable tank is stored (basement or cottage), could be ignited by any open flame or spark (furnace pilot light, etc.).
- **When boating**, fuel leaking under the engine cover could be ignited by a damaged or deteriorated electrical part or loose wire connection making stray sparks.

### How Can Fire and Explosion Be Minimized?

- **Read, understand, and follow** manufacturer's instructions
- Follow warnings marked "⚠" closely.
- **Do not** substitute fuel or electrical systems parts with other parts which may look the same. Some electrical parts, like starter motors, are of special design to prevent stray sparks outside their cases.
- Replace wires, sleeves, and boots which are cracked or torn or look in poor condition.

When mixing and refueling, always mix gas and oil outside...

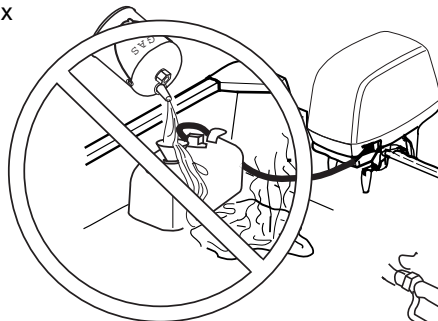
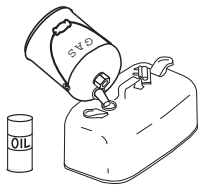

Always fill the tank outside the boat

Fumes are hard to control. They collect and hide in the bottom of the boat.

Remember:

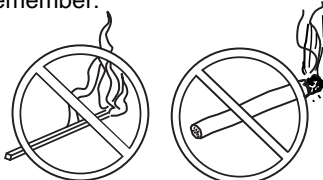

Do not use electrical devices such as cellular phones in the vicinity of a fuel leak or while fueling.



If you use a funnel, it has to be metal to ground the spout to the tank.

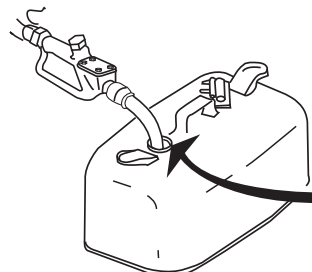

To avoid those static electric sparks, ground (touch) the spout against the tank.

If electrical parts are replaced or even removed from the outboard, check the following:

### Wire and high voltage lead routing

- As shown in service manual
- Away from moving parts which could cut wires or wire insulation
- Away from engine cover latches which can catch and cut insulation from high voltage spark plug leads

### Sleeves, boots, shields

- In position (to avoid shock hazard)
- Not torn or cracked

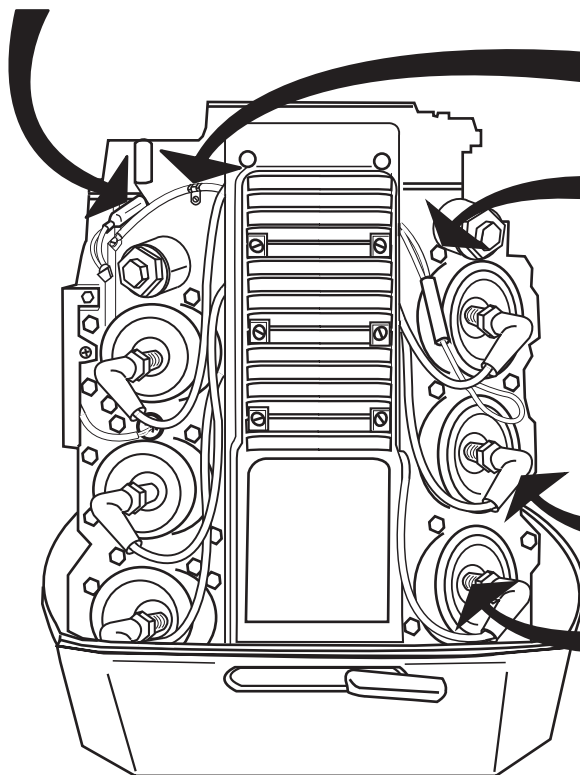

### Metal Clamps – Tie Straps

- Position as shown in manual

### Screws, Nuts, Washers

- Tighten firmly—these keep clamps in position and ends of wires from sparking
- Where lock washers are called for, use them

### Spark Plug Boots

- Not torn or cracked
- Fully pushed onto spark plug

### Spark Plugs

- Avoid rough handling that could crack ceramic part of plug. (Sparks may jump across outside of plug.)

In transom area:

### All Connections

- Clean
  - Tight
- (Prevents sparks)

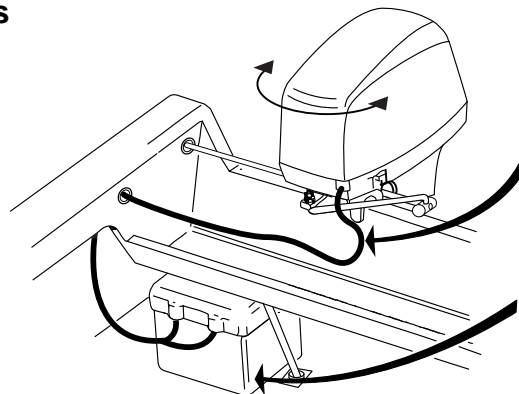

### Electric Cable

- Not rubbing on sharp objects
- Enough slack to allow full turning without pull loads on cable (prevents sparks)

### Batteries

- Secure in approved battery box or battery tray
- Battery terminals insulated
- No strain on cables

## SAFETY

After repair on any part of the fuel system, pressure test engine portion of fuel system as shown:

### When Storing:

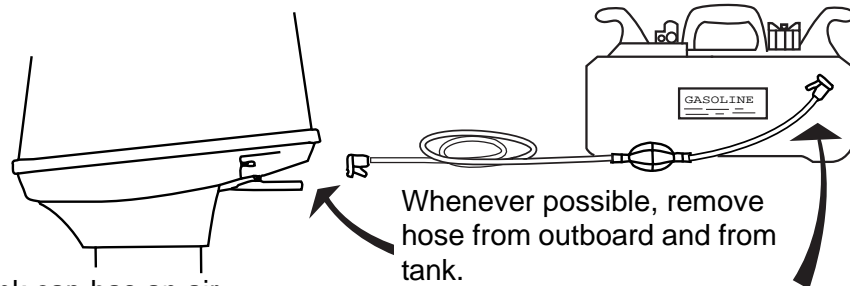
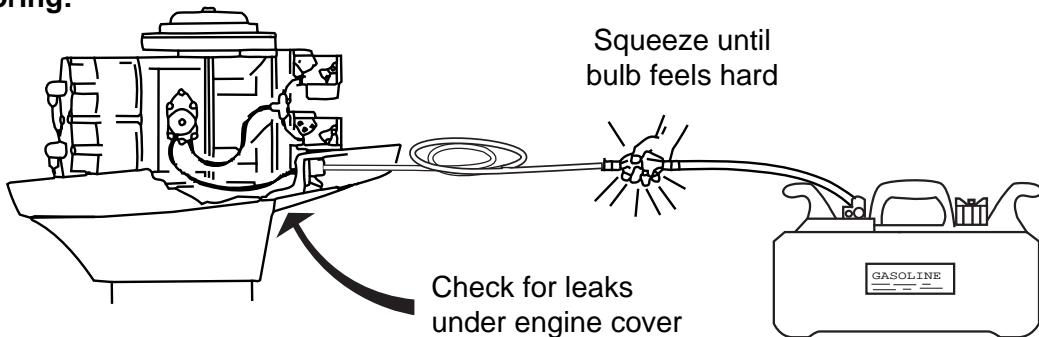

If tank cap has an air vent valve, make sure it is closed.

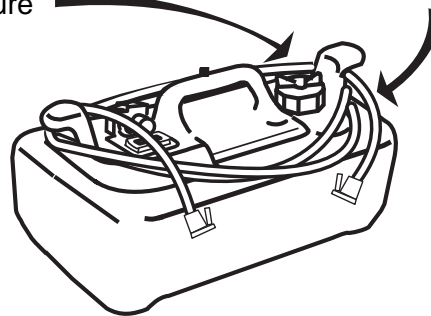

If gasoline tank is stored indoors, do not put it in a room having an appliance with a pilot light or where electrical appliances or switches (which may spark) will be used.

### When Running:

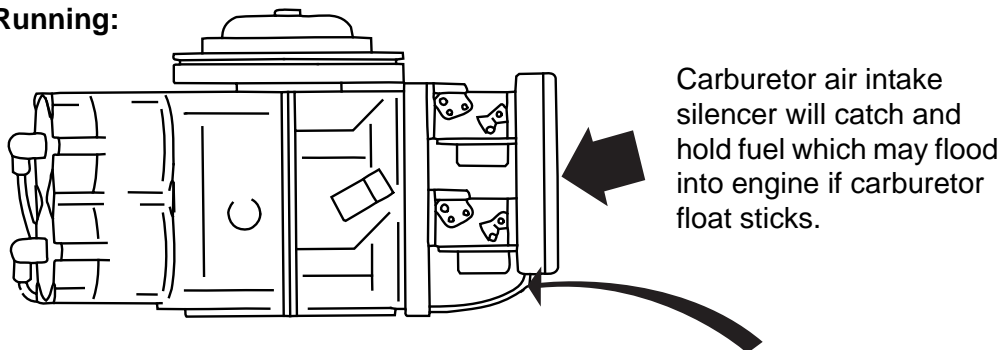

- Make sure silencer and its gaskets are on engine and drain hose is in place.
- Air silencer mounting screws are special lock screws. Use only the special screws.



## Outboard Mounting System and Safety

The mounting system includes:

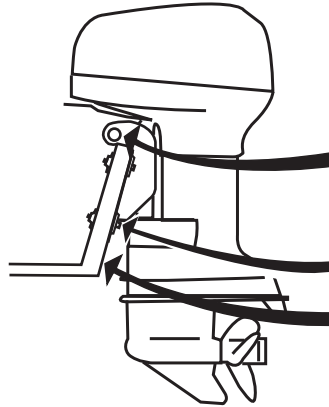

- outboard parts
- bolts, nuts, and washers
- boat's transom

### What is most important?

- Outboard must **stay** in position on boat's transom.

### What could happen?

Outboard may

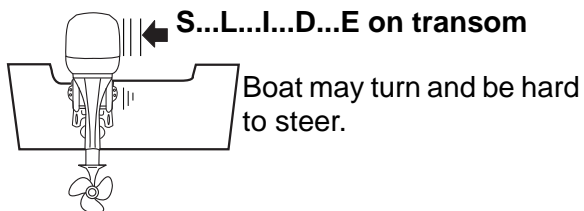

Outboard may

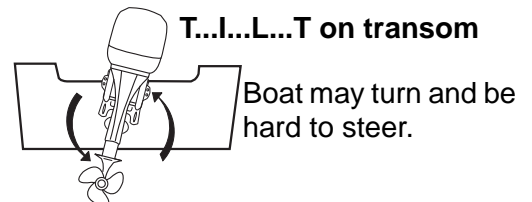

- If outboard hits something solid and does not stay on the transom, boat occupants may be injured from the outboard or its parts entering the boat.

Boat's transom could break away.

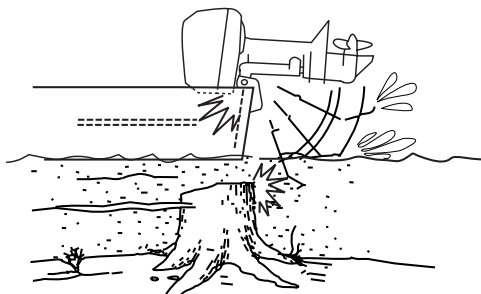

Outboard may be lost overboard.  
Boat may **SINK**.

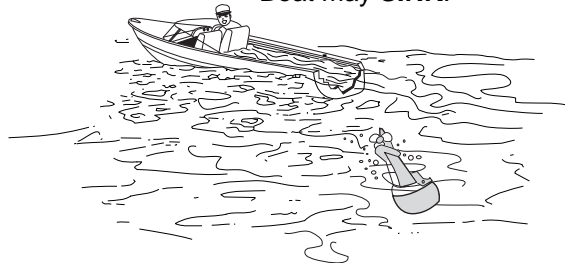

### How Can Loss of Mounting Be Minimized?

- **Read, understand, and follow** manufacturer's **instructions**.
- Follow warnings marked "⚠" closely.

# SAFETY

## If weakened, parts could fail later on the water, when not expected

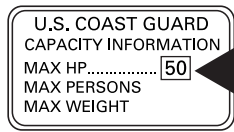

If boat plate shows...

Use only  
or smaller



When rigging or fixing any boat, if transom looks weak, tell the owner.

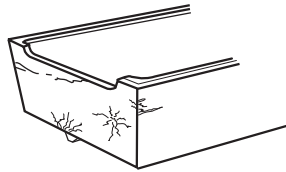

If transom is curved, outboard may come loose.

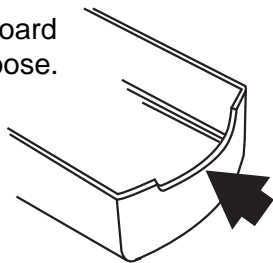

Mount on flat surface only.  
Use shims to make surface flat.

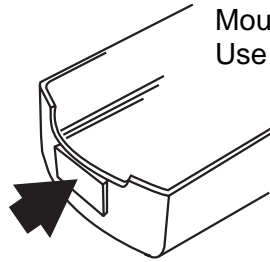

Use bolts, nuts, and washers supplied with outboard. They are usually special, and will not rust or weaken.



If owner tells you "I hit something really hard..."

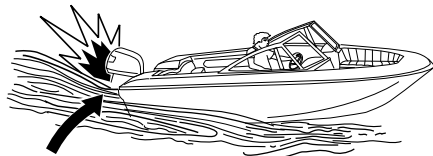

Check for a high speed blow to the lower unit.

OR...

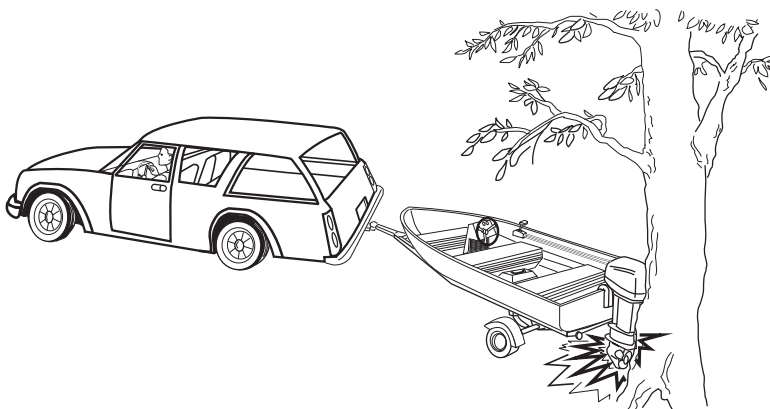

"I was backing up and I think the outboard may have hit a tree or something."

Check for a slow, heavy squash to the outboard.

- Look for damaged parts and loosened nuts and bolts in both the steering and mounting systems. Replace damaged parts.

## Outboard Hydraulic Tilt/Trim Shock Absorption System and Safety

### What is most important?

- Shock absorption system must always be ready to absorb some blows to the lower parts of the outboard.
- Outboard must not trim in too far suddenly.

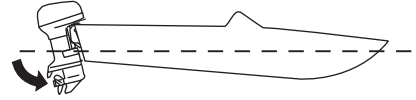

### What can happen?

Without shock protection, a blow like this could cause serious damage to the outboard and injury to boat occupants from the outboard or its parts entering the boat. Transom could break away and outboard may be lost overboard.

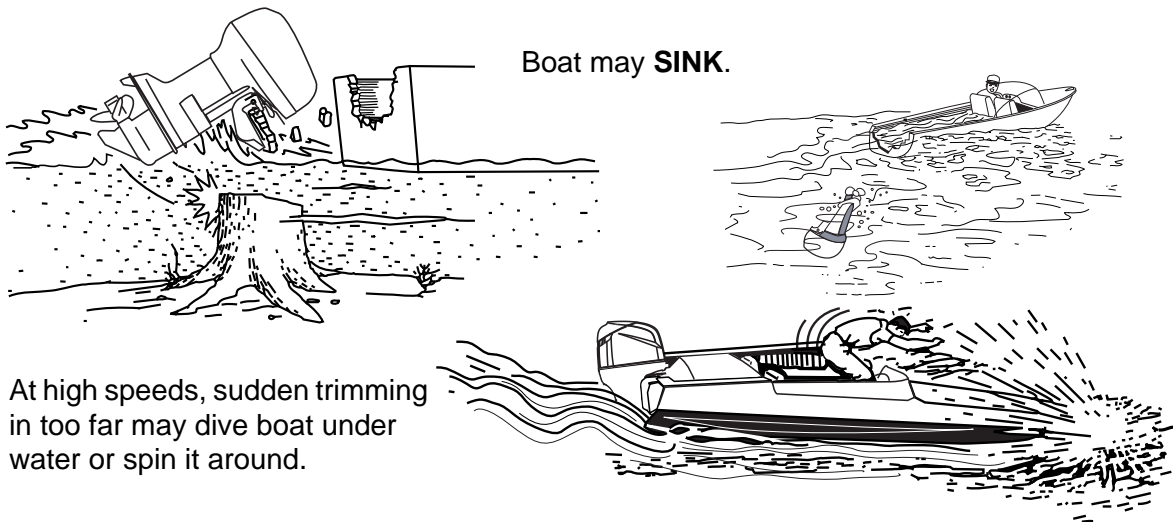

Boat may **SINK**.

At high speeds, sudden trimming in too far may dive boat under water or spin it around.

### How can possible conditions be minimized?

- **Read, understand, and follow** manufacturer's **instructions**.
- Follow warnings marked "⚠" closely.
- Test your work whenever possible.
- If oil leaks are seen in service areas, determine source. Keep reservoir filled.
- If outboard is hydraulic tilt/trim model, always return rod to hole position determined by boat operator and make sure angle adjusting rod retain is in locked position.

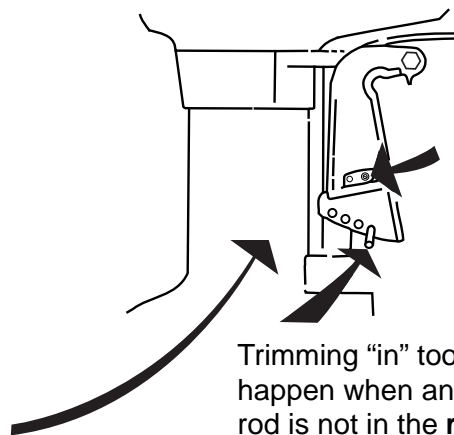

Make sure manual release valve is closed tight. Torque to 45 to 55 in. lbs. (5.1 to 6.2 N-m).

If left open, outboard has no shock protection.

Trimming "in" too far can happen when angle adjusting rod is not in the **right** hole or is not in **any** hole (lost).

## Outboard Emergency Stop System and Safety

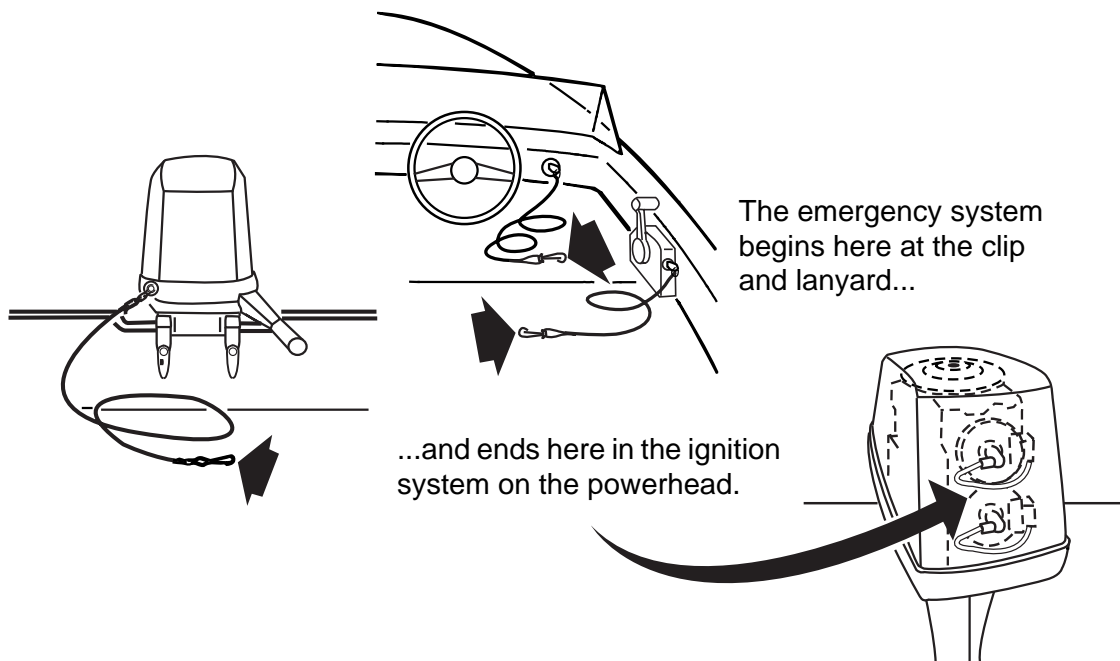

### What is most important?

- The emergency stop system must **STOP** the engine when the clip is removed or the lanyard pulled from the emergency stop / key switch.

### What could happen?

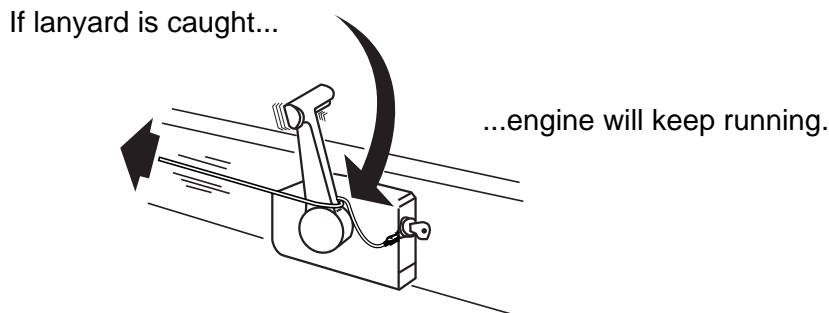
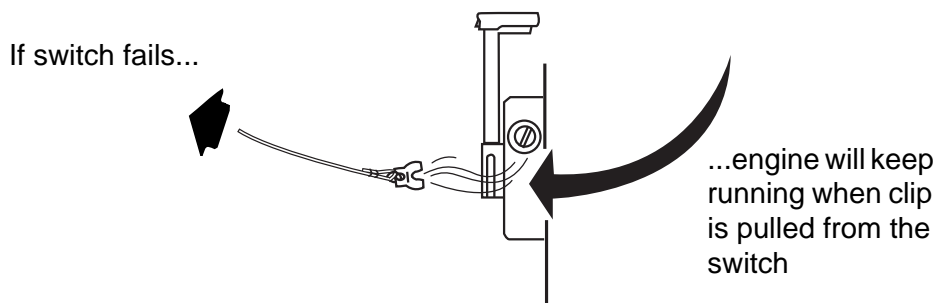

## What could happen?

If lanyard is cut or frayed...

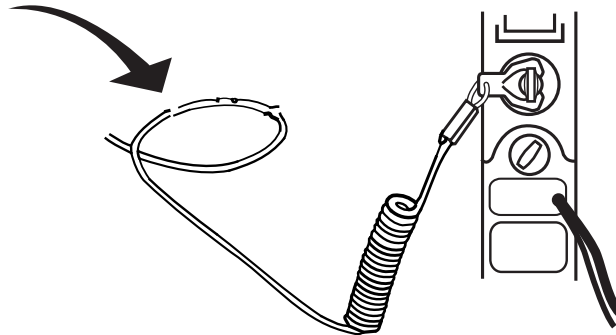

...lanyard or clip may break when pulled...

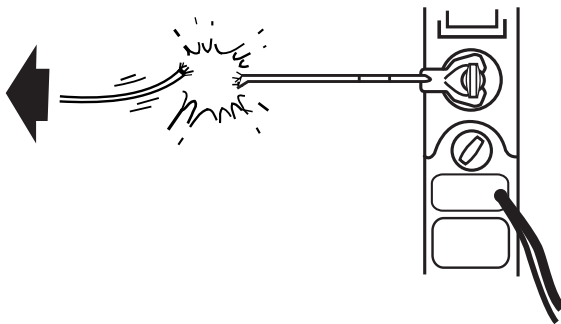

If engine does **NOT** stop when lanyard is pulled, an operator thrown from the boat could be hit as boat circles area. Or, boat may not turn but leave area as a runaway. Operator may drown and boat **WILL** run into something.

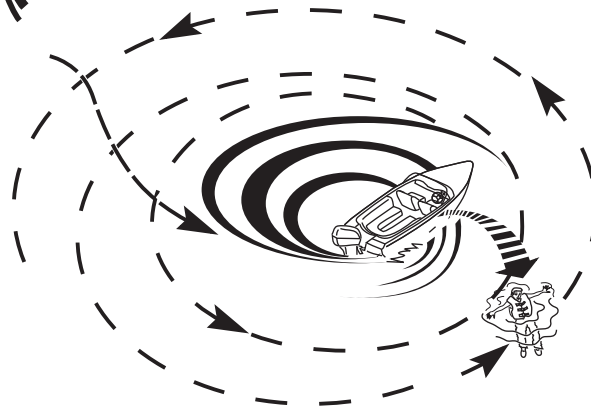

### How can failure of the emergency stop system be minimized?

- **Read, understand, and follow** manufacturer's instructions
  - Follow warnings marked "⚠" closely.
  - Assemble parts carefully.
  - Inspect lanyard for cuts or fraying; clip for wear. Replace with original parts. Do not substitute.
  - Locate control box and other items in area to keep lanyard from being caught.
  - **ALWAYS TEST EMERGENCY STOP SYSTEM. PULL LANYARD. ENGINE MUST STOP. IF IT DOES NOT, REPAIR BEFORE NEXT USE.**
- When rigging or after servicing**

## Summing up

Now you know some things that can take the joy out of boating.

### **No doubt about it—proper safety takes time!**

- Reading and understanding instructions
- Re-reading warnings marked “⚠”
- Putting parts together correctly
- Making correct adjustments
- Testing your work

### **And making sure**

- Worn or damaged parts are replaced
- Replaced parts are like originals in every way
- Customer is told of things which need attention

**But, do you really want the alternative?**

# MARINE PRODUCTS AND THE SAFETY OF PEOPLE WHO FIX THEM

The first part of this Safety section talked about safe boating and how you, the technician, can help keep it safe for the boater. But what about you? Technicians can be hurt while:

- Rigging boats
- Troubleshooting problems
- Fixing components
- Testing their work

Some of these safety issues you will know, others you may not.

## Handling Outboards

### When lifting outboards

Some outboards have a fixed lift bracket bolted to the powerhead. Because outboard will want to hang like this when off the floor...

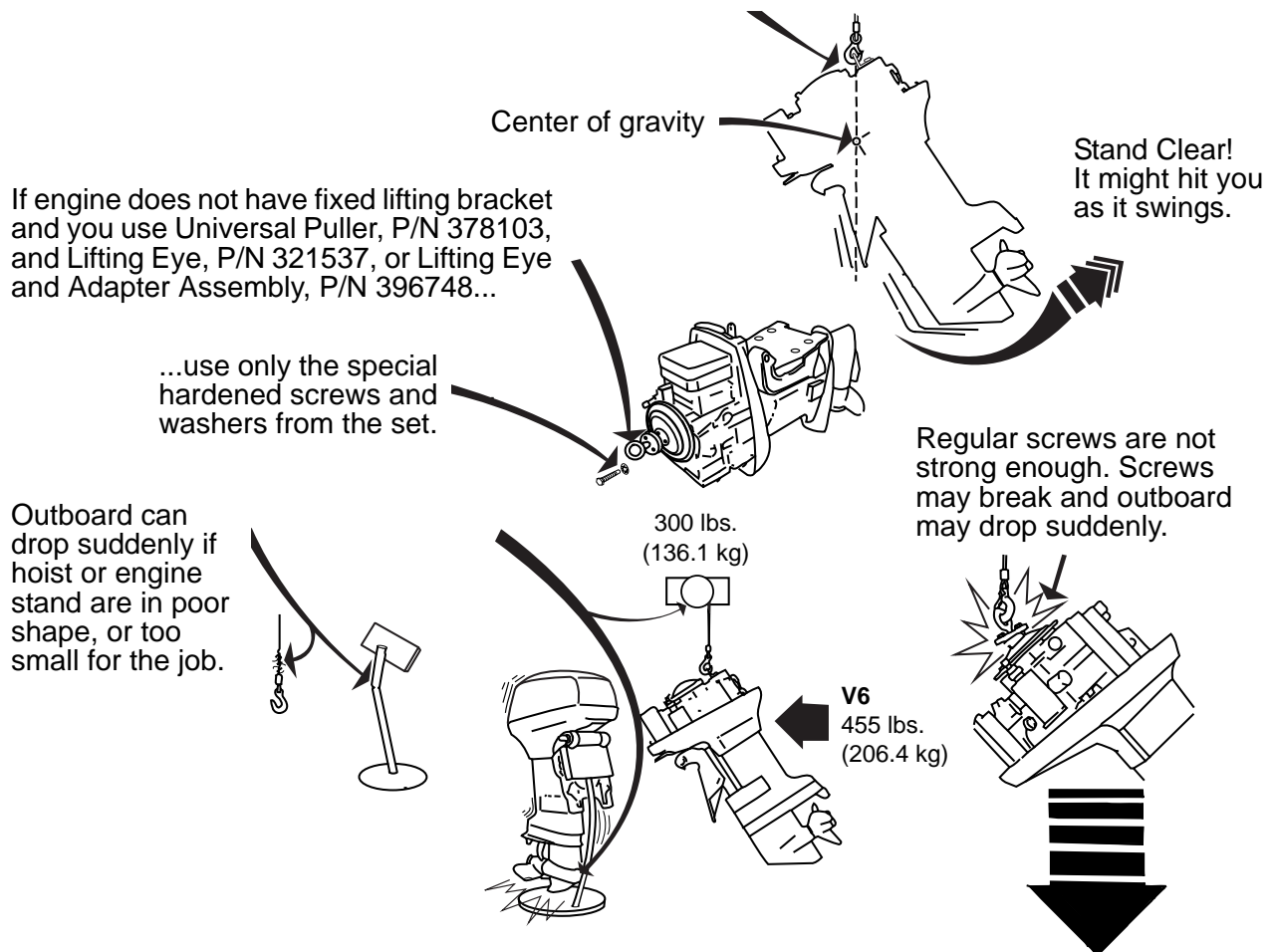

- Make sure shop aids have extra capacity, and keep them in good repair.

---

## SAFETY

---

### Running outboard with engine cover removed

Engine cover is a guard. When you remove cover/guard to work on the outboard, remember: loose clothing (open shirt sleeves, neckties), hair, jewelry (rings, watches, bracelets), hands and arms can be caught by the spinning flywheel.

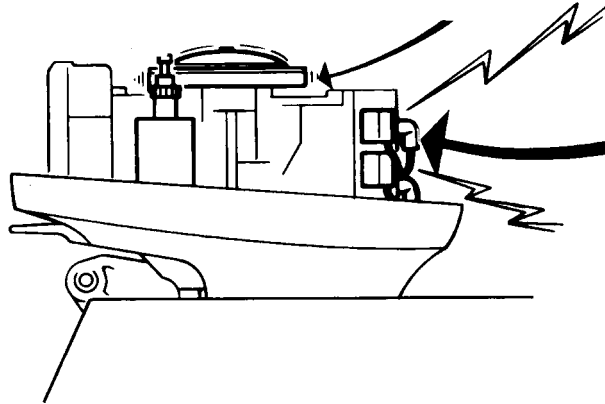

Handling high voltage parts like spark plugs and coils can shock you and may cause you to recoil into the rotating flywheel.

- Two people working together on a live outboard must look out for each other. Never, ever, use the key to start the outboard before signaling your partner. He may be leaning over the outboard with hands on the flywheel, handling a “hot” electrical part, or near the propeller.

### Outboard starting at the wrong time

When you do things that turn the flywheel like:

- Off-season storage fogging (oiling) of outboard;
- Removing propeller with a powered tool;
- Electrical system checks;
- Servicing the flywheel; or
- Any other actions **ALWAYS...**

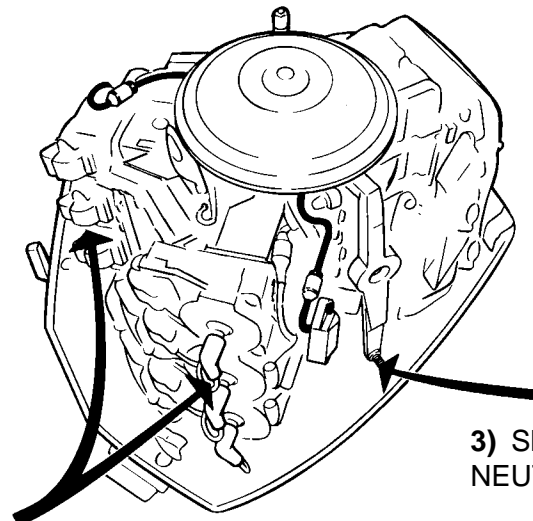

1) Turn key switch OFF

2) Twist and remove ALL spark plug leads

3) Shift to NEUTRAL

Check prop shaft. Is outboard really in NEUTRAL?

NO SPARK



NO START



NO SURPRISES



## Running outboard too fast (Overspeeding)

- “Too fast” means running faster than outboard normally runs on boat.

Running too fast can happen when:

### 1) Using a flushing device...

Turn on water before starting outboard. Keep engine speed below 2000 RPM. With no load, outboard will run too fast very easily. Wear eye protectors.

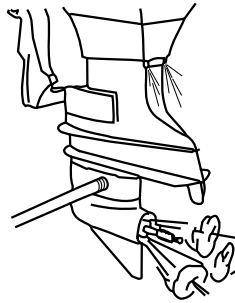

### 2) Running with the wrong test wheel...

This may happen if outboard runs too fast.

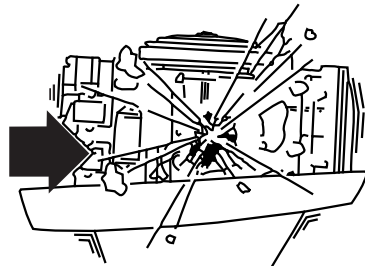

Use the right test wheel.

## Running outboards: Exhaust fumes

### DANGER

**DO NOT run the engine indoors or without adequate ventilation or permit exhaust fumes to accumulate in confined areas. Engine exhaust contains carbon monoxide which, if inhaled, can cause serious brain damage or death.**

- Whenever running the engine, assure there is proper ventilation to avoid the accumulation of carbon monoxide (CO), which is odorless, colorless, and tasteless, and can lead to unconsciousness, brain damage, or death if inhaled in sufficient concentrations. CO accumulation can occur while docked, anchored, or underway, and in many confined areas such as the boat cabin, cockpit, swim platform, and heads. It can be worsened or caused by weather, mooring and operating conditions, and other boats. Avoid exhaust fumes from the engine or other boats, provide proper ventilation, shut off the engine when not needed, and be aware of the risk of backdrafting and conditions that create CO accumulation. In high concentrations, CO can be fatal within minutes. Lower concentrations are just as lethal over long periods of time.

# SAFETY

## Running outboards: Propellers



### DANGER

Contact with a rotating propeller is likely to result in serious injury or death. Assure the engine and prop area is clear of people and objects before starting engine or operating boat. Do not allow anyone near a propeller, even when the engine is off. Blades can be sharp and the propeller can continue to turn even after the engine is off. Always shut off the engine when near people in the water.

### Eye protection

Eyes need protection when:

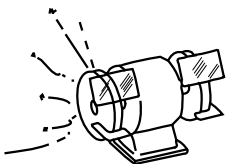
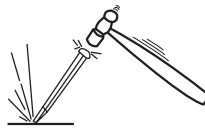
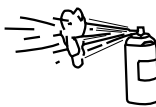
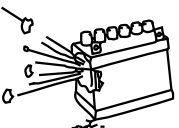

- Grinding 
- Chiseling   
Tip: When steel on steel, use plastic- or brass-type hammers. They don't chip off as easily as steel hammers.
- Spraying cleaners and paints 
- Acid 
- Ends of cables 

**Wear Safety Glasses** 

## Handling Lead/Acid Batteries

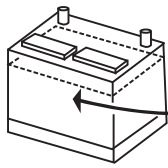

Strong acid solution  
(sulfuric acid)

If solution gets into eyes, wash  
and contact a doctor immediately.

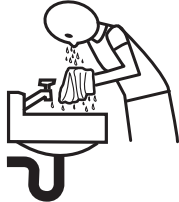

If spilled or  
splashed on any  
part of body...



Wash with  
lots of water.

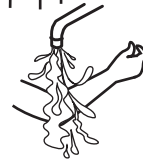

### Charging lead acid batteries

- 1) Attach and remove these cables with charger **UNPLUGGED** from 110 V wall socket. (This prevents shocks if charger is defective.)
- 2) Observe correct polarity when connecting these larger leads.
- 3) Always charge in a well ventilated area. Charging causes acid solution to give off hydrogen gas through the vents in the caps. **Make sure vents are open.** If clogged, pressure inside may build. Battery may **EXPLODE**.

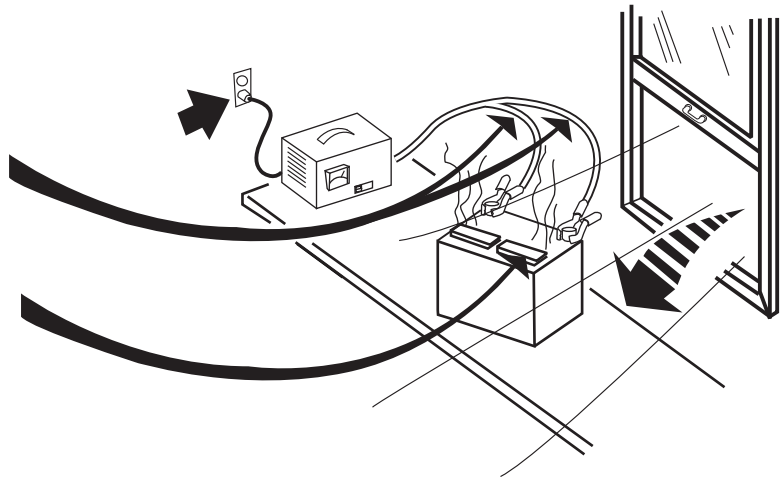

### Battery gas is explosive!

**While charging or discharging, remember:**

- No smoking
- No flames
- No sparks



Never remove charger cables from battery posts. It is a sure way to make a lot of sparks in an area surrounded by battery gas.

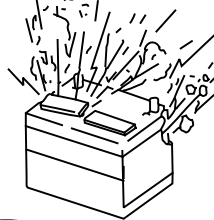

DO NOT check battery charge by placing metal objects across posts. You will make sparks and serious burns are possible.



**After charging:**

- Shut off charger
- Pull charger plug out of 110 V outlet
- Take charger cables off battery posts

## SAFETY

### Gasoline – Handle With Care!

Gasoline vapor and air mixtures explode easily and violently when mixed as shown...

When you smell ANY odor of gasoline, explosion is possible.

Gasoline fumes are heavy and will sink to the lowest point in the boat or room and will STAY there, WAITING...

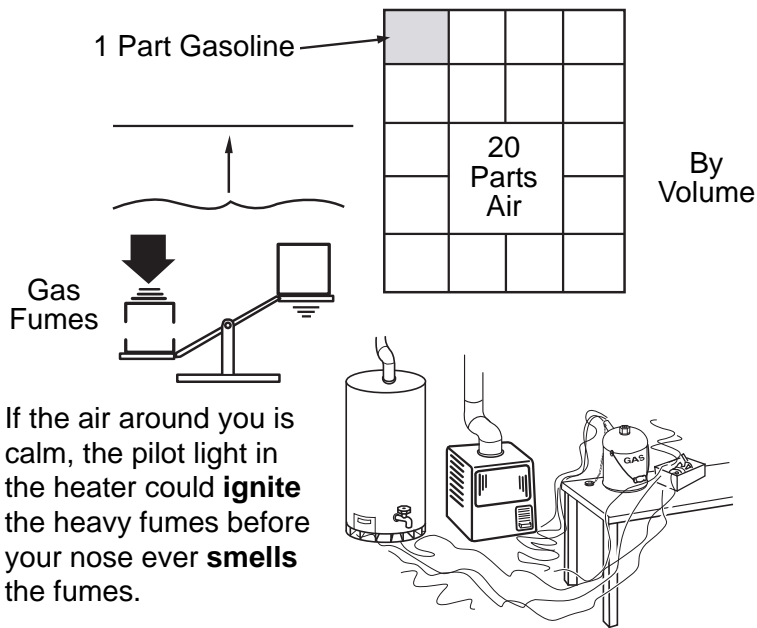

### What can you do?



Store gasoline in sturdy, approved, sealed gas can and keep outside.

- Always store gasoline outside in a safe can (flame arrester and pressure relief valve in pour spout).
- Fill portable tanks outside of boat. Spillage will collect in bottom of boat.
- Use fuel as fuel **ONLY**, **not** for a cleaner or degreaser.
- If fumes are smelled in shop, basement, or garage, **immediately**:
  - Put out open flames, cigarettes, sparking devices;
  - Wipe up spill or leak;
  - Get towels and rags outside fast;
  - Open doors and windows; and
  - Check **lowest** area for fumes.

Be aware of items in and around repair area which can ignite fumes. Control them if fumes are smelled.

- Matches, cigarettes, blow torches, welders
- Electric motors (with unsealed cases)
- Electric generators (with unsealed cases)
- Light switches
- Appliance pilot lights or electric ignitors (furnace, dryer, water heaters)
- Loose wires on running outboards
- Other variables which may ignite fumes

**How many of these are in your repair area?**

## Hazardous Products

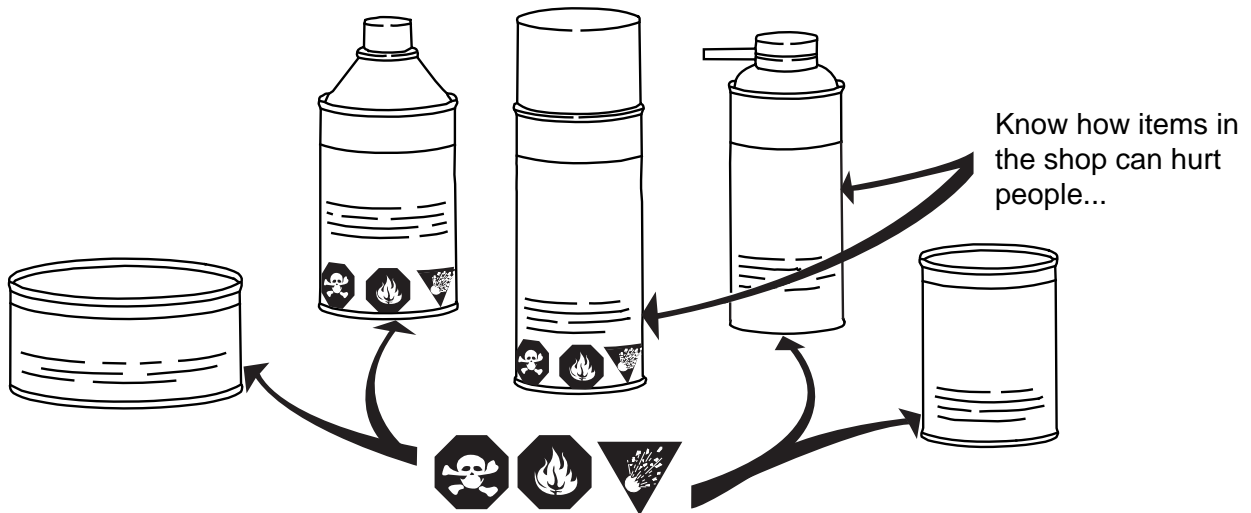

### READ

- “How and where to use”
- “How to give First Aid.” Have recommended First Aid materials on hand should an emergency arise
- “How to dispose of can”

It’s all on the **back of the can or bottle label**.

**And remember:** Little children are very curious and will try to taste everything so **keep containers away from children!**



## **Safety Awareness Test**

The Technician's Safety Awareness Test....

- 1) Did you read this Safety section from page S-1 to page S-24?
- 2) Are you ready to take responsibility for the safe maintenance practices and procedures of your repair shop, co-workers, and technicians?
- 3) Do you understand all the safety precautions and instructions contained in this entire service manual?
- 4) Will you follow all safety warnings, precautions, instructions and recommendations outlined in this service manual?
- 5) Do you understand that the service manual as a whole and this Safety section, in particular, contain essential information to help prevent personal injury and damage to equipment and your customers?
- 6) Have you received training related to common shop safety practices to protect yourself and others around you?
- 7) When replacement parts are required, will you use *Evinrude®/Johnson® Genuine Parts* or parts with equivalent characteristics, including type, strength and material?
- 8) Are you ready to follow the recommendations in this service manual before you service any boat or outboard?
- 9) Do you understand that safety-related accidents can be caused by carelessness, fatigue, overload, preoccupation, unfamiliarity of operator with the product, drugs and alcohol, just to name a few?

# INDEX

## A

### Abbreviations 6

### Accessories

- Battery Cable, P/N 584348 64
- XD100* Outboard Oil Decal, P/N 352369  
164

### Adjustments

- Control Cable 19, 276, 286
- Shift Linkage 220
- Shift Rod 11, 13, 300, 323
- Steering Friction 27
- Throttle Friction 27
- Tilt Limit Switch 28
- Timing Pointer 113
- TPS Calibration 114
- Trim Sending Unit 29, 30
- Trim Tab 31

### Air Silencer 43

### Air Temperature Sensor

- Connections 92
- Description 57
- Resistance Test 96

### Alternator Circuit Test 99

### AMP Connector Servicing 117

### Anodes

- Anti-Corrosion 44
- Continuity Check 44
- Gearcase 301, 324
- Propeller Shaft Bearing Housing 310, 335
- Stern Bracket 252, 254, 257

## B

### Batteries

- Charging System Tests 98
- Connections 24
- Maintenance 24
- Requirements 11, 13
- Storage 46

### Bearing

- Connecting Rod 209
- Crankshaft 198, 199, 203, 204
- Driveshaft 309, 334

Pinion Gear 305, 329

Propeller Shaft 310, 335, 336

Wrist Pin 197, 205

### Break-In

- EMM* Programming 165, 220
- Gearcase 298, 317, 320, 342
- Oiling 165
- Procedure 67

## C

### Capacitor Test 83

### Clamp Screw 258

### Connecting Rods

- Installation on Crankshaft 209
- Installation on Piston 205
- Orientation 205, 209
- Removal from Crankshaft 196
- Removal from Piston 197
- Tightening 209

### Control Cable

- Adjustments 19
- Installation 19

### Cooling System

- Adapter Housing 177
- Components 176
- Cylinder Block Venting 178
- EMM* and Vapor Separator Cooling 179
- Engine Temperature Check 180
- Exhaust Housing 176
- Flushing 35
- Hose Routing and Water Flow 174
- Operating Temperatures 11, 13, 34
- Operation 179
- Pressure Relief Valve 177, 183
- Running on a hose 36
- Thermostat 11, 13, 177
- Thermostats 177, 182
- Vapor Separator 133
- Water Intake Screens 34, 305, 328, 338
- Water Pump 176, 298, 320
- Water Supply Tube 176, 248, 249

### Corrosion

---

## INDEX

---

- Anodes 44, 252, 254, 257, 301, 310, 324, 335
- Cylinder walls 200
- Long Term Storage 45
- Metal components 44
- Steering Cable 37
- Cover Service** 50
- Crankcase**
  - Assembly 211
  - Disassembly 195
- Crankshaft**
  - Assembly 203, 208
  - Disassembly 197
  - Inspection 201
- Crankshaft Position Sensor**
  - Description 59
  - Operation Test 80
  - Resistance Test 95
- Cylinder Bore**
  - Honing 200
  - Inspection 201
- Cylinder Head**
  - Inspection 201
  - Installation 207
  - Removal 196
- D**
- Deutsch Connector Servicing** 116
- Diagnostic Procedures**
  - Dynamic Tests 76
  - Fuel Delivery Tests 84
  - Ignition Tests 79
  - LED Indicators 77
  - Strategy 74
- Diagnostic Software**
  - Break-In Programming 165
  - Communication With Outboard 63
  - Crankshaft Position Sensor 80
  - Cylinder Drop Tests 76
  - Diagnostic Procedures Overview 74
  - Fuel Injector Programming 68, 146
  - Fuel Injector Tests 84
  - Fuel Pump Test 84
  - I-Command* settings 23
  - Idle Speed Control 68
  - Oil Injector Test 167
  - Oil Priming 170
  - Oiling Rate 66, 164
  - Reports 69
  - Sensor Monitoring 95
  - Service Codes 65
  - Static Ignition Test 81
  - Timing Verification 67, 114
  - TPS Calibration 68, 114
- Driveshaft**
  - Installation 314, 340
  - Removal 303, 325
  - Service 327
  - Shimming 312, 337
- Driveshaft Bearing Housing** 309, 334
- Dual-Outboard**
  - Alignment 32
  - I-Command* settings 23
- E**
- Electrical Circuits**
  - EMM* Pin Locations 92
  - Fuse 94
  - Ground Circuits 94
  - Key Switch 102
  - Start Circuit 100
  - SystemCheck* 107
- Electrical Connectors**
  - AMP* Connectors 117
  - Deutsch* Connectors 116
  - Packard* Connectors 119
- Electrical Harness**
  - Connections 20, 21
- Emergency Stop Switch**
  - Operation Check 33
  - Test 105
- Emissions Information** 7
- EMM***
  - 12 V Circuit Sensor 56
  - Connections 54, 55, 92
  - Diagnostics 63, 74
  - Functions 54, 60
  - LED Indicators 77
  - Sensors 56, 57
  - Service Codes 65
  - Servicing 70
  - Software Replacement 69
  - Timing Verification 114



- TPS Calibration 114
- Transfer 70
- Engine Monitor**
  - Description 61
  - Low Oil Warning 58, 162, 168
  - No Oil Warning 162
  - Operation Check 33
- Engine Temperature Check** 180
- Engine Temperature Sensor**
  - Description 57
  - Resistance Test 96
- Exhaust Housing**
  - Assembly 249
  - Cleaning and Inspection 249
  - Installation 245, 247
  - Removal 243, 246
- Exhaust Water Valve**
  - Service 244
  - Tests 86, 106
- Exterior Finish Protection** 44
- F**
- Flushing, Cooling System** 35
- Flywheel**
  - Installation 111
  - Removal 110
- Fuel Injectors**
  - Crush Ring Replacement 146
  - Electrical Circuits 128
  - EMM* Programming 146, 147
  - Installation 147
  - Removal 146
  - Tests 138, 139
- Fuel System**
  - Additives 10, 12, 131
  - Components 132
  - Filter 132, 143
  - Fuel Circulation Pump 84, 134, 139
  - Fuel Filter 43
  - Fuel Lift Pump 132, 139, 141, 143
  - Fuel Manifolds 145
  - Fuel Requirements 131
  - Hose Routing 126
  - Injector Servicing 68
  - Intake Manifold 149
  - Minimum Octane 10, 12, 131
  - Pressure Tests 137
  - Priming 136
  - Relieving Pressure 142
  - Requirements 130
  - Troubleshooting 76, 84, 137
  - Vapor Separator 132, 144
- Fuse** 94
- G**
- Gearcase**
  - Assembly 313, 338
  - Disassembly 301, 324
  - Inspection 301, 324
  - Installation 297, 319
  - Leak Test 295
  - Lubricant 11, 13, 39
  - Removal 296, 318
- Grommet** 18, 19
- H**
- Honing** 200
- Hoses**
  - Grommet 18
  - Inspection 43
  - Oil Distribution 169
  - Oil Recirculation System 163
  - Routing, Cooling System 174
  - Routing, Fuel System 126
- I**
- I-Command**
  - Outboard connections 21
  - System settings 23
  - Water Pressure Gauge 23
- Idle Speed** 10, 60, 68
- Ignition**
  - Control Circuit Tests 83
  - Electrical Circuits 90, 91
  - Ignition Coil Servicing 112
  - Ignition Coil Tests 83
  - Required Systems 79
  - Running Tests 82
  - Static Ignition Test 81
  - Timing 67
- Information Display Systems**
  - Tachometer Setting 33

---

## INDEX

---

### **Intake Manifold**

- Assembly 150
- Disassembly 150
- Inspection 150
- Installation 151
- Removal 149

## **K**

### **Key Switch**

- Operation Check 33
- Start Circuit 102

## **L**

### **LED Indicators 77**

### **Lower Cover**

- Installation 51
- Removal 50

### **Lubrication**

- Engine Oil 10, 12, 160
- Gearcase 11, 13, 39
- Power Trim 11, 13
- Propeller Shaft 39
- Swivel Bracket 38
- Throttle and Shift Linkage 38
- Tiller handle 37
- Tilt Tube 38
- Trailing Bracket 38
- Trim and Tilt 41

## **M**

### **Maintenance Schedule 16**

### **Manual Starter**

- Assembly 365
- Installation 369
- Rope Replacement 368

### **Manual Tilt**

- Assembly 268
- Disassembly 265

### **Models**

- Included Models 9
- Model Designation 8
- Serial Number Location 8

### **Motor Mounts**

- Lower Mount Servicing 243, 245, 246, 247
- Upper Mount Servicing 215, 243, 245, 251, 253, 258

### **Muffler**

- Installation 219
- Removal 192
- Servicing 244

## **N**

### **New Engines**

- Outboard Rigging Procedure 17

## **O**

### **Oetiker Clamp Servicing 25**

### **Oil Injector**

- Electrical Circuit (55 V) 161
- Electrical Tests 166
- Functional Test 168

### **Oiling Rate 66, 164**

### **Oiling System**

- Components 160
- Electrical Circuits 159
- Engine Lubricant 10, 12, 160
- Low Oil Switch 58
- New Engine Set-Up 160
- Oil Distribution 156
- Oil Distribution Hoses 156, 169
- Oil Filters 43
- Oil Recirculation 163
- Oil Tank 160, 169
- Oiling Rate 66, 164
- Priming 165
- Servicing 169
- Tests 166

### **Outboard Excessive Smoking T-5**

### **Outboard Hard to Start T-3**

### **Outboard Starts and Stalls T-4**

### **Outboard Starts, Low Maximum RPM T-5**

### **Outboard Surges, Runs Rough T-6**

### **Outboard Will Not Start T-1**

### **Outboard Won't Shut Off T-4**

## **P**

### **Packard Connector Servicing 119**

### **Pinion Gear**

- Bearing Installation 305, 329
- Bearing Removal 305, 329
- Installation 314, 340
- Removal 303, 325

**Piston Rings**

- End Gap 202, 206
- Installation 206
- Removal 197

**Pistons**

- Assembly 205
- Inspection 202
- Installation 206
- Removal 196

**Powerhead**

- Assembly 203
- Cleaning 200
- Cylinder Compression Testing 190
- Disassembly 193
- Inspection 201
- Installation 216
- Removal 190

**Predelivery Checks** 33**Pre-Season Service** 46**Pressure Relief Valve**

- Assembly 184
- Disassembly 183
- Inspection 184

**Priming**

- Fuel System 136

**Propeller**

- Inspection 293
- Installation 294
- Selection 293

**Propeller Shaft**

- Installation 313, 338
- Lubrication 39
- Removal 304, 328

**Propeller Shaft Bearing Housing**

- Disassembly 310, 335
- Installation 316, 341
- Removal 302, 325

**R****Relays**

- Trim and Tilt 106, 349

**Remote Controls**

- Cable Adjustment 19

**Rigging**

- Outboard 17

**Rope Replacement** 368**RPM Limit** 11, 13, 59, 60**S****S.A.F.E.**

- Description 62
- Low Oil 58
- No Oil 162
- Temperature 56, 57

**Safety** 1**Sensor Tests** 95**Sensors**

- Air Temperature Sensor 57, 96
- Barometric Pressure Sensor 57
- Crankshaft Position Sensor 59, 80, 95
- EMM 56
- Engine Temperature Sensor 57, 96, 182
- Throttle Position Sensor 59, 95

**Service Charts**

- Electrical and Ignition 88
- Fuel System 122
- Gearcase 290
- Manual Starter 362
- Midsection 234
- Oiling System 154

**Shift Cable Adjustment, Tiller** 286**Shift Housing**

- Assembly 307, 332
- Installation 313, 338
- Removal 304, 328

**Shift Linkage**

- Adjustment 220
- Installation 212
- Lubrication 38
- Removal 194

**Shift Rod**

- Housing Installation 339

**Shift Rod Adjustment** 11, 13, 300, 323**Shimming, Driveshaft** 312, 337**Shutdown** 62

- No Oil 162

**Spark Plugs**

- Gap 11, 42
- Indexing 42
- Maintenance Schedule 16
- Recommendation 11, 13, 42
- Removal 42

---

## INDEX

---

- Replacement 42
  - Service 42
  - Specifications** 10
  - Starter**
    - Assembly 365
    - Circuit Description 100
    - Current Draw Test 103
    - Installation 115, 369
    - Removal 115
    - Rope Replacement 368
    - Solenoid Test 102
    - Voltage Drop Test 103
  - Start-In-Gear Protection** 33
  - Stator**
    - Resistance Test 97
    - Service 111
    - Voltage Output Test 97
  - Steering Handle**
    - Assembly 273, 281
    - Disassembly 272, 278
    - Inspection 273, 281
    - Installation 275, 285
    - Removal 271, 277
  - Steering System**
    - Lubrication 37
    - Steering Arm and Shaft 251, 253, 257, 259
    - Steering Friction 27, 259
    - Steering Torque 31
  - Stern Bracket**
    - Assembly 252, 256, 261
    - Disassembly 251, 253, 258
    - Manual Tilt 265
    - Removal 252, 260
  - Stop Circuit** 105
  - Storage** 45
  - Submerged Engines** 47
  - Swivel Bracket**
    - Installation 257
    - Lubrication 38
    - Manual Tilt 265
    - Removal 254
  - SystemCheck**
    - Circuits 107
    - LOW OIL Warning Signal 162
    - NO OIL Warning Signal 162
    - Outboard connections 20
  - Tests 107, 108, 109
  - Winterization Procedure 45
- ## T
- Tachometer**
    - Pulse Setting 33
  - Technical Data** 10
  - Temperature**
    - Operating 34, 180
    - Operation below freezing 160
    - Sensors 57
  - Temperature Sender**
    - Service 182
  - Thermostat**
    - Assembly 183
    - Description 177
    - Disassembly 182
    - Inspection 183
    - Temperature 11, 13
  - Throttle Cable Adjustment, Tiller** 276, 287
  - Throttle Linkage**
    - Installation 213
    - Lubrication 38
    - Removal 194
  - Throttle Position Sensor**
    - Description 59
    - Resistance Test 95
  - Tiller Adjustments**
    - Steering Friction Adjustment 27
  - Tiller handle**
    - Lubrication 37
  - Tilt Limit Switch**
    - Adjustment 30
    - Cam Installation 241, 242
  - Tilt Support** 346
  - Tilt Tube**
    - Installation 242, 253
    - Lubrication 38
    - Removal 241, 252
  - Timing Adjustments**
    - Timing Verification 114
    - TPS Calibration 114
  - Timing Pointer Adjustment** 113
  - Tools**
    - Accessory Power Cable Kit, P/N 5008092

- Backing Plate, P/N 325867 304, 326  
Ball Socket Installer tool, P/N 342225 276,  
287  
Ball Socket Remover tool, P/N 342226 149,  
271, 277  
Battery Cable, P/N 584348 64  
Bearing Installation Tool, P/N 326562 311,  
336  
Bearing Installation Tool, P/N 339750 336  
Bearing Puller, P/N 432130 310  
Bootstrap Tool, P/N 586551 69  
Collar, P/N 328363 312  
Collar, P/N 341440 337  
Connector Service Tool, P/N 342667 116  
Crankshaft Bearing/Sleeve Installer, P/N  
338647 203  
Crimp Tool, AMP 117  
Crimping Pliers, P/N 322696 116  
Diagnostic Interface Cable, P/N 437955 63  
Diagnostic Power Supply, P/N 587005 63,  
80  
Driveshaft Holding Socket, P/N 311875  
325, 341  
Driveshaft Holding Socket, P/N 334995  
303, 316  
Driveshaft Puller, P/N 390706 326  
Driveshaft Seal Protector, P/N 312403 312,  
313, 315  
Driveshaft Seal Protector, P/N 318674 337,  
338, 340  
Driveshaft Shimming Tool, P/N 5005925  
312, 337  
Electrical Test Probe Kit, P/N 342677 99  
Flywheel Holder, P/N 771311 111  
Fuel Pressure Gauge, P/N 5006397 139  
Fuel Pressure Gauge, P/N 5007100 137,  
142  
Gauging Head, P/N 352879 328  
Gearcase Alignment Gauge Kit, P/N  
5006349 328  
Gearcase Filler, P/N 501882 40  
Gearcase Pressure Tester, P/N 507977  
295  
Gearcase Vacuum Tester, P/N 507982 295  
Guide Pins, P/N 383175 317  
Injector Test Fitting Kit, P/N 5005844 138  
Key Switch Assembly, P/N 176408 64  
Large Puller Jaws, P/N 432129 199, 309,  
310, 334, 335  
Lifting Fixture, P/N 396748 191, 192, 216,  
218  
Lower Driveshaft Puller, P/N 342681 326  
Oetiker Pincers, P/N 787145 26  
Peak Reading Voltmeter, P/N 507972 98  
Pinion Bearing Remover and Installer, P/N  
5005927 305  
Pinion Bearing Remover/Installer, P/N  
5005927 305, 329  
Pinion Nut Holder, P/N 334455 325, 341  
Pinion Nut Starting Tool, P/N 320675 315  
Pinion Nut Starting Tool, P/N 342216 340  
Piston Stop Tool, P/N 342679 113  
Primary Lock Tool, P/N 777077 117  
Puller Bridge, P/N 432127 309, 310, 334,  
335  
Puller, P/N 387206 304  
Retaining Ring Pliers, P/N 331045 302, 316  
Rod Cap Alignment Fixture, P/N 396749  
209  
Seal Installation Tool, P/N 326551 311, 336  
Seal Installation Tool, P/N 330268 334  
Seal Installation Tool, P/N 336311 336  
Seal Installer, P/N 342665 309  
Secondary Lock Installer, P/N 777079 117  
Secondary Lock Tool, P/N 777078 117  
Shim Gauge Bar, P/N 328366 312  
Shim Gauge Bar, P/N 328367 337  
Slide Hammer Adapter, P/N 340624 352  
Slide Hammer Adaptor Kit, P/N 390898 146  
Slide Hammer, P/N 391008 146, 203, 326,  
352  
Slide Hammer, P/N 432128 199, 242  
Small Puller Jaws, P/N 432131 335  
Starter Rope Threading Tool, P/N 378774  
368  
Starter Winder/Installer Kit, P/N 392093  
365  
Stator Test Adaptor, P/N 5005799 97, 98  
Syringe, P/N 346936 168  
Temperature Gun, P/N 772018 180, 181  
Terminal Release Tool, P/N 351413 118  
Thermal Joint Compound, P/N 322170 181

---

## INDEX

---

Tilt Tube Service Kit, P/N 434523 241  
Torquing Socket, P/N 331638 196, 210  
*Twist-Grip* Remover, P/N 390767 272, 279  
Universal Puller Set, P/N 378103 111, 302, 325  
Universal Shift Rod Height Gauge, P/N 389997 300, 323  
Wrench Retainer, P/N 341438 325, 341  
Wrist Pin Bearing Tool, P/N 336660 205  
Wrist Pin Cone, P/N 318600, 206  
Wrist Pin Pressing Tool, P/N 326356 197  
Wrist Pin Retaining Ring Driver, P/N 318599 206

### **Torque Charts**

see Service Charts

### **TPS Calibration** 114

### **Trailing Bracket** 346

Lubrication 38

### **Trim and Tilt**

Assembly 358

Disassembly 356

Electrical Circuit Tests 106

Inspection 348

Installation 354

Lubrication 41

Removal 352

Reservoir Fluid 11, 348

Troubleshooting 348, 349

### **Trim Gauge Test** 351

### **Trim Sender**

Adjustment 29, 30

Test 351

### **Trim Tab**

Adjustment 31

Installation 297

Removal 296, 318

### **Troubleshooting**

Charging System Tests 98

Cylinder Drop Tests 76

Diagnostic Procedures 74

Fuel Control Adjustment 76

Fuel System 84, 137

Ignition 79, 82

Oiling System 166

Sensors 95

Stator Resistance Test 97

Strategy 75

Trim and Tilt 348, 349

## **U**

### **Upper Mount Servicing** 215

## **V**

### **Vapor Separator**

Description 132

Installation 144

Removal 144

### **Voltage Drop Test** 103

## **W**

### **Water Intake Screens** 34, 305, 328, 338

Inspection 34

### **Water Pressure Gauge** 23

### **Water Pump**

Assembly 299, 321

Description 176

Disassembly 298, 320

Inspection 298, 320

### **Water Tube** 248, 249

### **Winterizing** 45

### **Wrist Pin**

Bearing 197

Installation 205

Removal 197

# TROUBLE CHECK CHART

## OUTBOARD WILL NOT START

OBSERVATION	POSSIBLE CAUSE	PROCEDURE
Outboard does not turn over	Battery switch not ON	Check battery switch operation
	Discharged battery	Check battery, recharge or replace
	Battery cables and connections	Clean and tighten connections. Check for voltage drop in starter circuit.
	Faulty connection or ground, damaged electrical harness	Check all grounds, connections and wiring
	Fuse (10 A)	Check wiring, then replace faulty fuse
	Wiring harness	Check for 12 V at terminal "B" of key switch
	Key switch	Check key switch operation
	Starter solenoid	Check wiring and test solenoid
	Starter or bendix/drive gears	Check starter, inspect bendix/drive gears
	Seized powerhead or gearcase	Check and repair as needed
Outboard turns slowly	Discharged battery	Check battery, recharge or replace
	Battery cables and connections	Clean and tighten connections. Check voltage drop in starter circuit.
	Powerhead hydro-locked	Check cylinders for water
	Partially seized powerhead or gearcase	Check and repair as needed
	Starter or bendix/drive gears	Check starter, inspect bendix/drive gears

**TROUBLE CHECK CHART**  
**OUTBOARD WILL NOT START**

**OUTBOARD WILL NOT START**

OBSERVATION	POSSIBLE CAUSE	PROCEDURE
Outboard turns over	Stop circuit grounded	Check wiring and emergency stop switch. Check the safety lanyard is installed and stop circuit is not grounded.
	In gear—Tiller models	Make sure outboard is in neutral
	No Fuel	Check for fuel in fuel tank
	Water in fuel	Check fuel filter, sample fuel from fuel return manifold.
	Contaminated or poor fuel quality	Check or replace fuel supply
	Fuel supply restricted	Check primer, anti-siphon valve, and fuel pick-up. Use primer to fill vapor separator with fuel.
	Air in fuel system	Check for air in fuel supply manifold, refer to <b>FUEL SYSTEM</b> (vapor separator venting and fuel supply)
	Low or no fuel pressure to injectors	Check fuel manifold pressure, refer to <b>FUEL SYSTEM</b>
	Incorrect, fouled, or worn spark plugs	Replace spark plugs
	Fuel injectors not working	Check voltage at injectors
	Excessive fuel or oil, engine flooded	Check for leaking injectors, leaking fuel or oil lift pump, or leaking vapor separator vent, refer to <b>FUEL SYSTEM</b>
	Low or no 55 V alternator output	Check voltage on 55 V circuit, refer to <b>SYSTEM ANALYSIS</b> and <b>ELECTRICAL AND IGNITION</b>
	Capacitor or 55 V circuit wiring	Check capacitor and 55 V circuits, refer to <b>SYSTEM ANALYSIS</b> and <b>ELECTRICAL AND IGNITION</b>
	Ignition	Check ignition, refer to <b>SYSTEM ANALYSIS</b> and <b>ELECTRICAL AND IGNITION</b>
	CPS input to <i>EMM</i> , no sync	Check RPM reading while cranking
	No ignition system control signal from <i>EMM</i> to ignition coils	Check cranking RPM (300 minimum), refer to <b>SYSTEM ANALYSIS</b>
	Low or no compression	Check compression
	Water in engine	Check condition of spark plugs and cylinders
	Internal powerhead damage	Check and repair as needed
	Leaking cylinder/crankcase, intake manifold, or reed valves	Check and repair as needed
<i>EMM</i> program, timing, or operation	Check <i>EMM</i> program and timing; check injector information (by location and serial number)	
Neutral switch, tiller models	Check neutral switch operation	



## OUTBOARD HARD TO START

OBSERVATION	POSSIBLE CAUSE	PROCEDURE
Outboard eventually starts, may or may not run properly once started	Weak battery	Check battery, recharge or replace
	Battery cables and connections	Clean and tighten connections, check voltage drop on high amperage circuit
	Starter or bendix/drive gears	Check starter, inspect bendix/drive gears
	Water in fuel system	Check water separator/fuel filter, sample fuel from fuel return manifold test port
	Contaminated or poor fuel quality	Check or replace fuel supply
	Air in fuel system	Check for air in fuel supply manifold, refer to <b>FUEL SYSTEM</b> (vapor separator venting and fuel supply)
	Incorrect, fouled, or worn spark plugs	Replace spark plugs
	Low fuel pressure	Check pressure, refer to <b>FUEL SYSTEM</b>
	Fuel supply restricted	Check primer bulb, anti-siphon valve, and fuel pick-up, check for fuel system air leaks
	Low or no alternator output (55 V)	Check voltage on 55 V circuit, refer to <b>SYSTEM ANALYSIS</b> and <b>ELECTRICAL AND IGNITION</b>
	Capacitor or 55 V circuit wiring	Check capacitor and 55 V circuit (white/red), refer to <b>SYSTEM ANALYSIS</b> and <b>ELECTRICAL AND IGNITION</b>
	Restricted or leaking fuel injector(s)	Check injectors, refer to <b>FUEL SYSTEM</b>
	Weak or erratic ignition operation	Check ignition, refer to <b>SYSTEM ANALYSIS</b> and <b>ELECTRICAL AND IGNITION</b>
	Crankshaft Position Sensor (CPS)	Check CPS air gap and <i>EMM</i> LED indicators
	Excessive fuel or oil, engine flooding	Check for leaking injectors, leaking fuel or oil lift pump, or leaking vapor separator vent. Refer to <b>SYSTEM ANALYSIS</b> .
	<i>EMM</i> program, timing, or operation	Check <i>EMM</i> program and timing; check injector coefficients; and monitor injector circuits and ignition primary outputs
Internal powerhead damage	Check and repair as needed	
Leaking cylinder/crankcase, intake manifold, or reed valves	Check and repair as needed	

**TROUBLE CHECK CHART**  
**OUTBOARD WILL NOT SHUT OFF**

**OUTBOARD WILL NOT SHUT OFF**

OBSERVATION	POSSIBLE CAUSE	PROCEDURE
Outboard starts and runs, normal performance while running	Key switch or wire harness ground	Check key switch and ground to key switch, refer to <b>SYSTEM ANALYSIS</b> and <b>ELECTRICAL AND IGNITION</b>
	Stop circuit wiring	Check <i>EMM</i> LED indicators. Check wire harness (black/yellow) and key/stop switch(s).
	<i>EMM</i> failure	Check <i>EMM</i> LED indicators and eliminate stop circuit as possible cause. Stop wire (black/yellow) has 4.0 VDC from <i>EMM</i> with key on or outboard running.

**OUTBOARD STARTS AND STALLS**

OBSERVATION	POSSIBLE CAUSE	PROCEDURE
Outboard may not run for more than a few seconds	Faulty wiring, connections, or grounds	Check all grounds, connections, and wiring
	Incorrect, fouled, or worn spark plugs	Replace spark plugs
	Low or no alternator output (55 V)	Check voltage on 55 V circuits, refer to <b>SYSTEM ANALYSIS</b> and <b>ELECTRICAL AND IGNITION</b>
	Capacitor or 55 V circuit wiring	Check capacitor and 55 V circuit, refer to <b>SYSTEM ANALYSIS</b> and <b>ELECTRICAL AND IGNITION</b>
	Contaminated or poor fuel quality	Check or replace fuel supply
	Low fuel pressure	Check pressure, refer to <b>FUEL SYSTEM</b>
	Air in fuel system	Check for air in fuel supply manifold, refer to <b>FUEL SYSTEM</b> (vapor separator venting and fuel supply)
	Fuel supply restricted	Check primer bulb, anti-siphon valve, and fuel pick-up, check for fuel system air leaks
	Injector electrical circuit or control function	Check voltage at injectors, refer to <b>SYSTEM ANALYSIS</b>
	Restricted or leaking fuel injector(s)	Check injectors, refer to <b>FUEL SYSTEM</b>
	<i>EMM</i> program, timing, or operation	Check <i>EMM</i> program and timing; check injector coefficients; and monitor injector control wires and ignition primary outputs
	Weak or erratic ignition output	Check ignition, refer to <b>SYSTEM ANALYSIS</b> and <b>ELECTRICAL AND IGNITION</b>
	Internal powerhead damage	Check and repair as needed

## OUTBOARD STARTS, LOW MAXIMUM RPM

OBSERVATION	POSSIBLE CAUSE	PROCEDURE
<i>SystemCheck</i> light	Outboard is in <i>S.A.F.E.</i>	Check Service Codes and <i>SystemCheck</i> warning
Setup or rigging change	Incorrect propeller	Refer to specifications, check recommended WOT RPM; water test and install correct pitch propeller
	Incorrect outboard mounting height	Refer to installation guidelines
Performance of outboard at lower speeds appears normal	Incorrect, fouled, or worn spark plugs	Replace spark plugs
	Contaminated or poor quality fuel	Check or replace fuel supply
	Fuel supply restricted	Check primer bulb, anti-siphon valve, and fuel pick-up, check for fuel system air leaks
	Low alternator output (55 V)	Check voltage on 55 V circuits, refer to <b>SYSTEM ANALYSIS</b> and <b>ELECTRICAL AND IGNITION</b>
	Weak or erratic ignition operation	Check ignition, refer to <b>SYSTEM ANALYSIS</b> and <b>ELECTRICAL AND IGNITION</b>
	Fuel injector electrical circuit or control function	Check voltage at injectors, refer to <b>SYSTEM ANALYSIS</b>
	Restricted or leaking fuel injectors	Check injectors, refer to <b>FUEL SYSTEM</b>
	Low fuel pressure	Check circulation pump operation, refer to <b>FUEL SYSTEM</b>
	<i>EMM</i> programming, timing, or operation	Check <i>EMM</i> program and timing; check injector coefficients; and monitor injector circuits and ignition primary outputs
Restricted engine exhaust	Check and repair as needed	

## EXCESSIVE SMOKING

OBSERVATION	POSSIBLE CAUSE	PROCEDURE
May coincide with increased oil consumption (normal if occurs after winterization)	Contaminated or poor fuel quality	Check or replace fuel supply
	Excessive fuel or oil consumption	Check fuel system for fuel supply air leaks or leaking fuel injectors
	Outboard in break-in mode	Use diagnostics program to check
	Outboard mounted too low	Check installation height of outboard
	Vapor separator vent	Check vapor separator assembly for proper venting/float valve operation
	Faulty/leaking fuel injector(s)	Check injectors, refer to <b>FUEL SYSTEM</b>
	Damaged fuel lift pump	Check for internal leaks

**TROUBLE CHECK CHART**  
**OUTBOARD SURGES, RUNS ROUGH**

**OUTBOARD SURGES, RUNS ROUGH**

OBSERVATION	POSSIBLE CAUSE	PROCEDURE
1200 RPM and above	<i>S.A.F.E.</i>	Access <i>EMM</i> fault codes
May be erratic or inconsistent	Incorrect, fouled, or worn spark plugs	Replace spark plugs
	Water in fuel system	Check water separator/fuel filter, sample fuel from fuel return manifold test port
	Contaminated or poor fuel quality	Check and replace fuel supply
	Low or erratic fuel pressure	Check pressure, refer to <b>FUEL SYSTEM</b>
	Air in fuel system	Check for air in fuel supply manifold, refer to <b>FUEL SYSTEM</b> (vapor separator venting and fuel supply)
	Fuel supply restricted	Check primer bulb, anti-siphon valve, and fuel pick-up, check for fuel system air leaks
	Restricted or leaking fuel injector(s)	Check injectors, refer to <b>FUEL SYSTEM</b>
	Faulty wiring, connections, grounds, or CPS air gap	Check all grounds, connections, and wiring. Check CPS air gap.
	Low alternator output (55 V)	Check voltage on 55 V circuit, refer to <b>SYSTEM ANALYSIS</b> and <b>ELECTRICAL AND IGNITION</b>
	<i>EMM</i> program, timing, or operation	Check <i>EMM</i> program and timing; check injector coefficients; and monitor injector circuits and ignition primary outputs
	Weak or erratic ignition operation	Check ignition, refer to <b>SYSTEM ANALYSIS</b> and <b>ELECTRICAL AND IGNITION</b>
	Capacitor or 55 V circuit wiring	Check capacitor and 55 V circuit (white/red), refer to <b>SYSTEM ANALYSIS</b> and <b>ELECTRICAL AND IGNITION</b>
Audible noise	Restricted engine exhaust	Check and repair as needed
	Internal powerhead damage	Check and repair as needed
	Damaged gearcase	Inspect gearcase and lubricate

# Hose Routing and Water Flow Diagram

## 40 – 65 E-TEC Inline 2 Cylinder

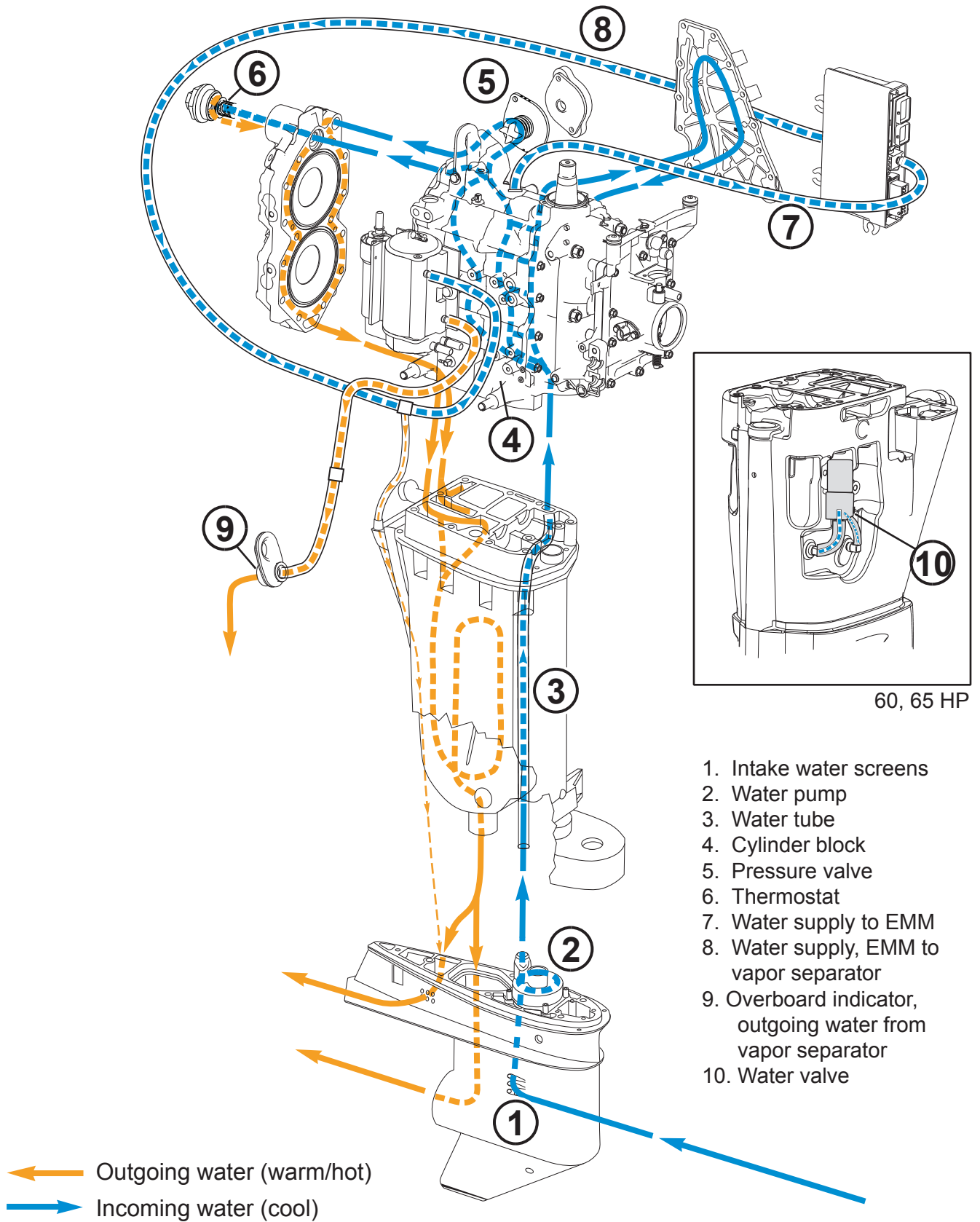

# Hose Routing and Water Flow Diagram 75-90 HP EVINRUDE ETEC

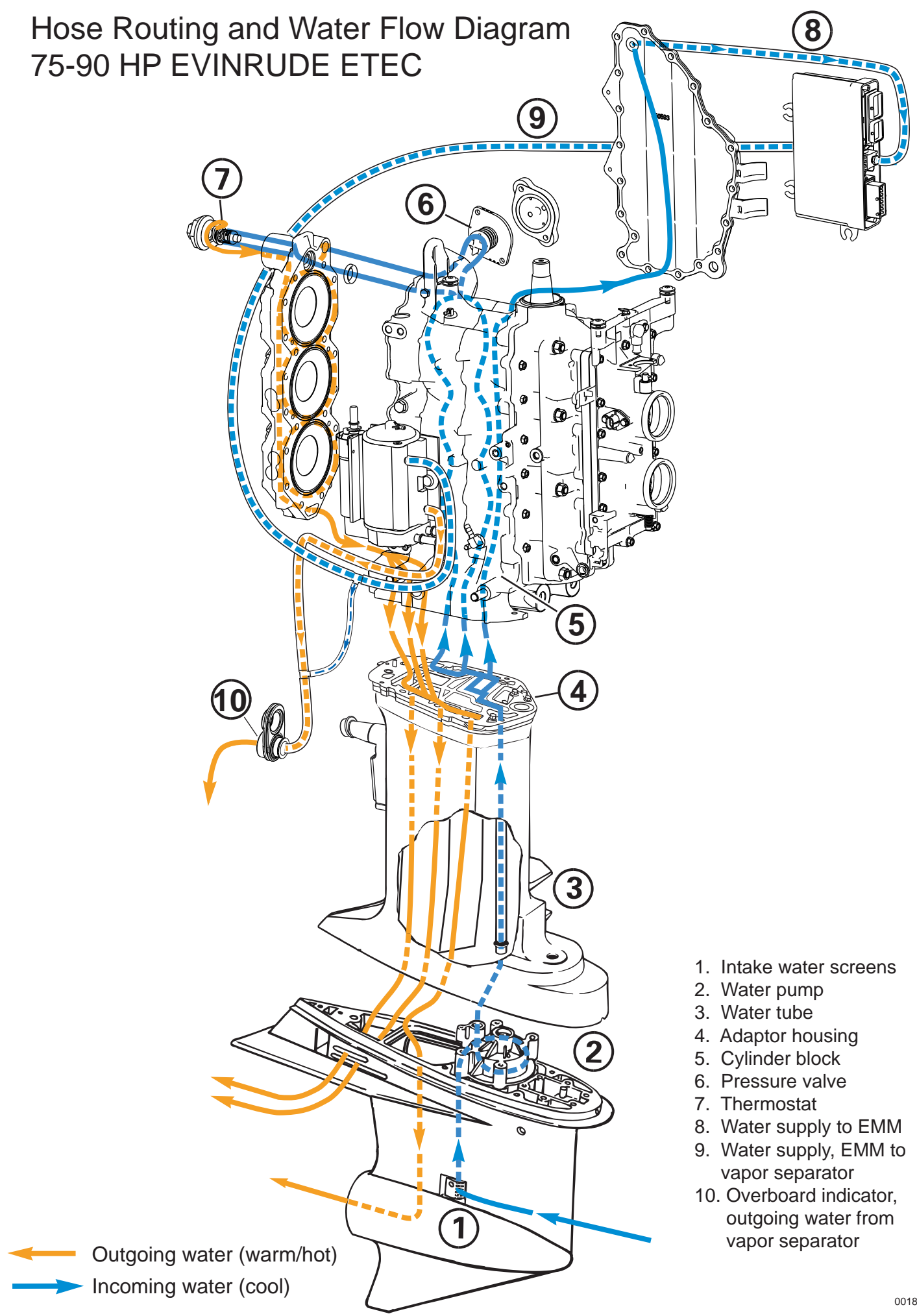

- 1. Intake water screens
- 2. Water pump
- 3. Water tube
- 4. Adaptor housing
- 5. Cylinder block
- 6. Pressure valve
- 7. Thermostat
- 8. Water supply to EMM
- 9. Water supply, EMM to vapor separator
- 10. Overboard indicator, outgoing water from vapor separator

← Outgoing water (warm/hot)  
→ Incoming water (cool)



# I-Command Keyswitch/TNT Wiring Harness

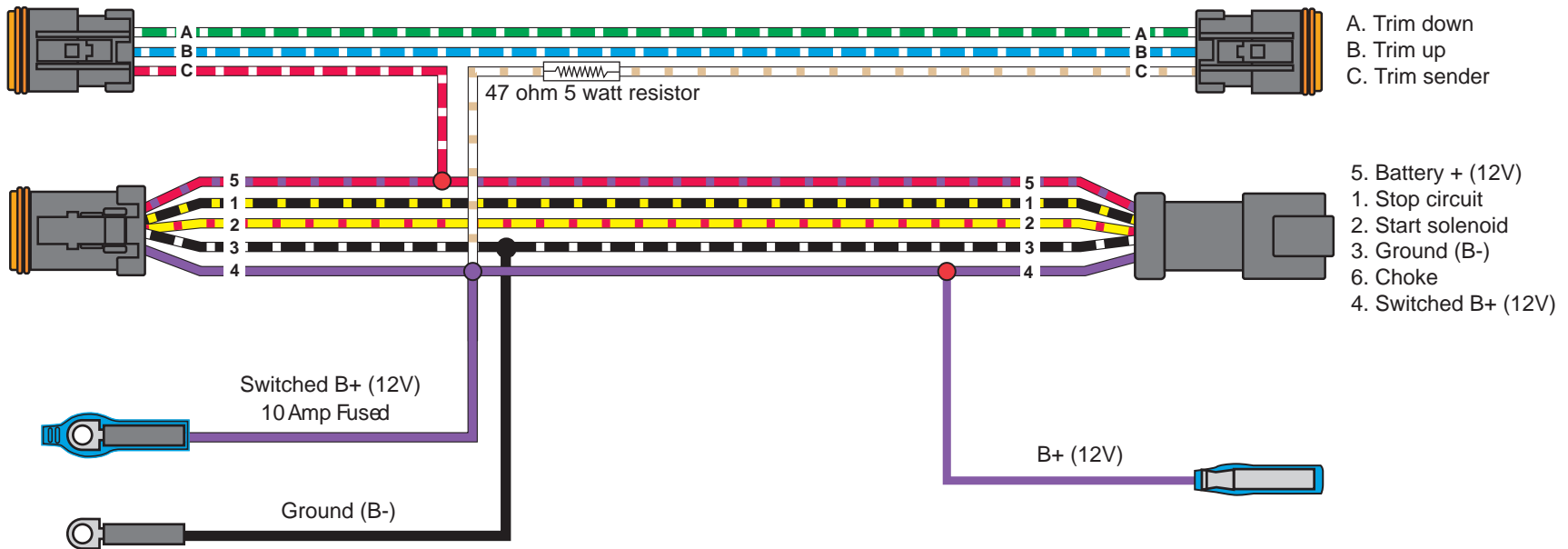



# MWS Key Switch and Neutral Safety Switch

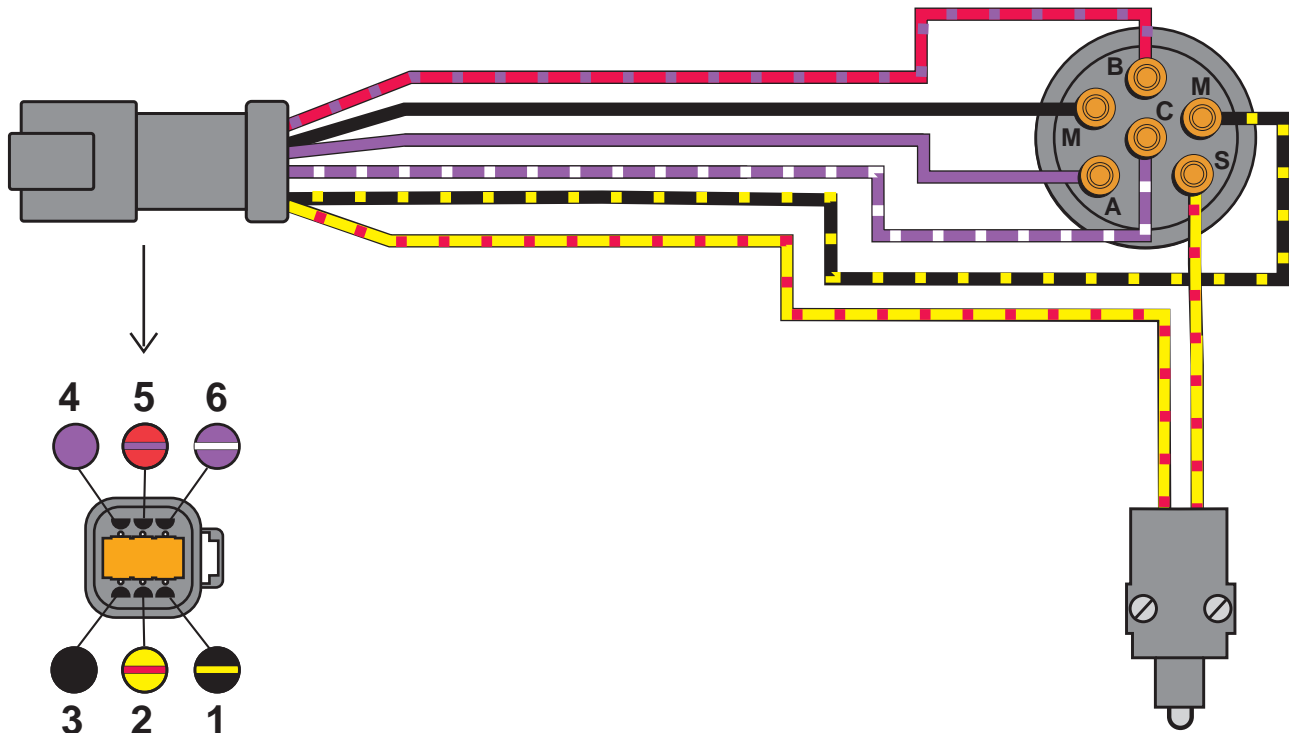
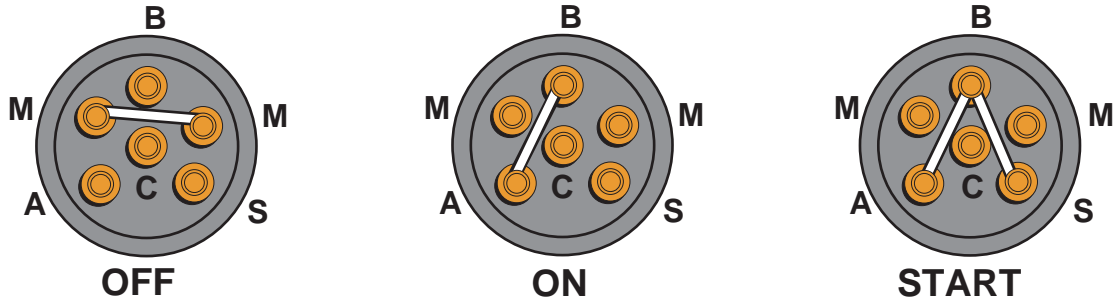

# MWS DASHBOARD

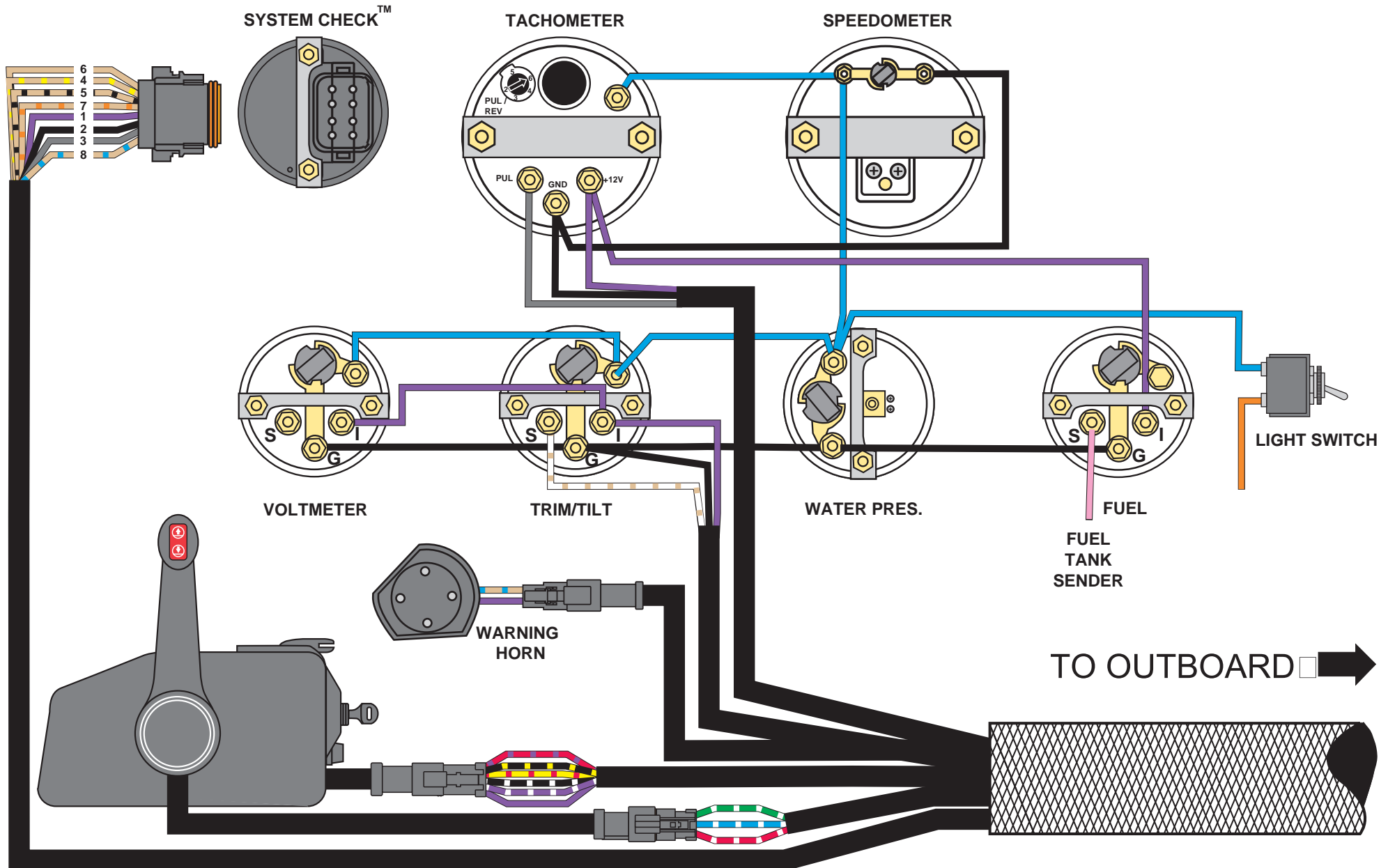

# Evinrude E-TEC

## EMM LED Diagnostic Indicators

### In-line Models

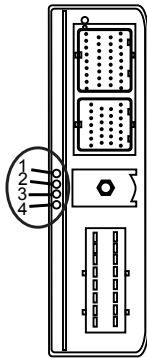

- |   |   |                                   |   |   |
|---|---|-----------------------------------|---|---|
| 1 | ⊗ | Charging / 55V Circuit            | ⊗ | 1 |
| 2 | ⊗ | CPS OK - Injection/Ignition/Fault | ⊗ | 2 |
| 3 | ⊗ | Sensors / 5V Circuits             | ⊗ | 3 |
| 4 | ⊗ | Stop Circuit - No Oil/Overheat    | ⊗ | 4 |

### V Models

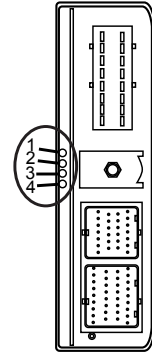

For more information, refer to **SYSTEM ANALYSIS** in the Service Manual.

### KEY ON : LED's illuminate to indicate circuit function

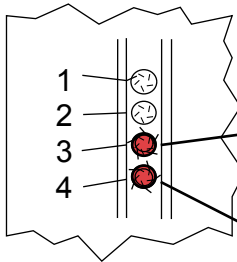

- Start assist circuit (SAC) OK (V models only) ————
- Sensors / 5V Circuits OK ————
- FLASHING LED – URGENT condition – Code 57  
Engine will not start – Correct problem and clear codes
- Stop circuit OK ————
- FLASHING LED – URGENT overheat or no oil condition  
Engine will not start – Correct problem and clear codes

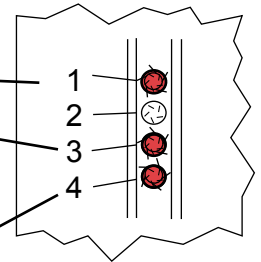

**Note:** No LED's ON indicates EMM not receiving battery voltage or Recoil Start model.

### STARTING : LED's illuminate to indicate circuit function

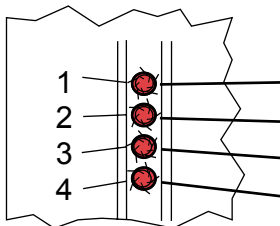

- Indicates 30V (or higher) on 55V circuit
- Indicates CPS working and EMM SYNC
- Sensor circuits working
- Stop circuit OK

### RUNNING : LED's illuminate to indicate circuit fault

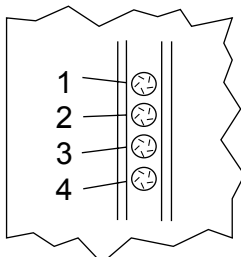

Exception: ALL LED's ON / FLASHING indicates Winterization Mode



# 40 – 65 HP E-TEC

1. Air Temperature Sensor
2. Throttle Position Sensor
3. Neutral Switch
4. Stator
5. Crankshaft Position Sensor
6. Trim/Tilt Connector
7. SystemCheck Connector
8. Key Switch Connector
9. High Pressure Fuel Pump
10. CANbus Connector
11. Diagnostic Connector
12. Temperature Sensor
13. Ignition Coil
14. Fuel Injector
15. Fuse (10 Amp)
16. Starter Solenoid
17. Main Harness Ground
18. Electric Starter
19. EMM
20. Oil Injector
21. Low Oil Switch
22. Trim/Tilt Relay Module
23. Capacitor
24. Trim/Tilt Motor
25. Water Valve Connector
26. Trim Sending Unit
27. Trim/Tilt Switch

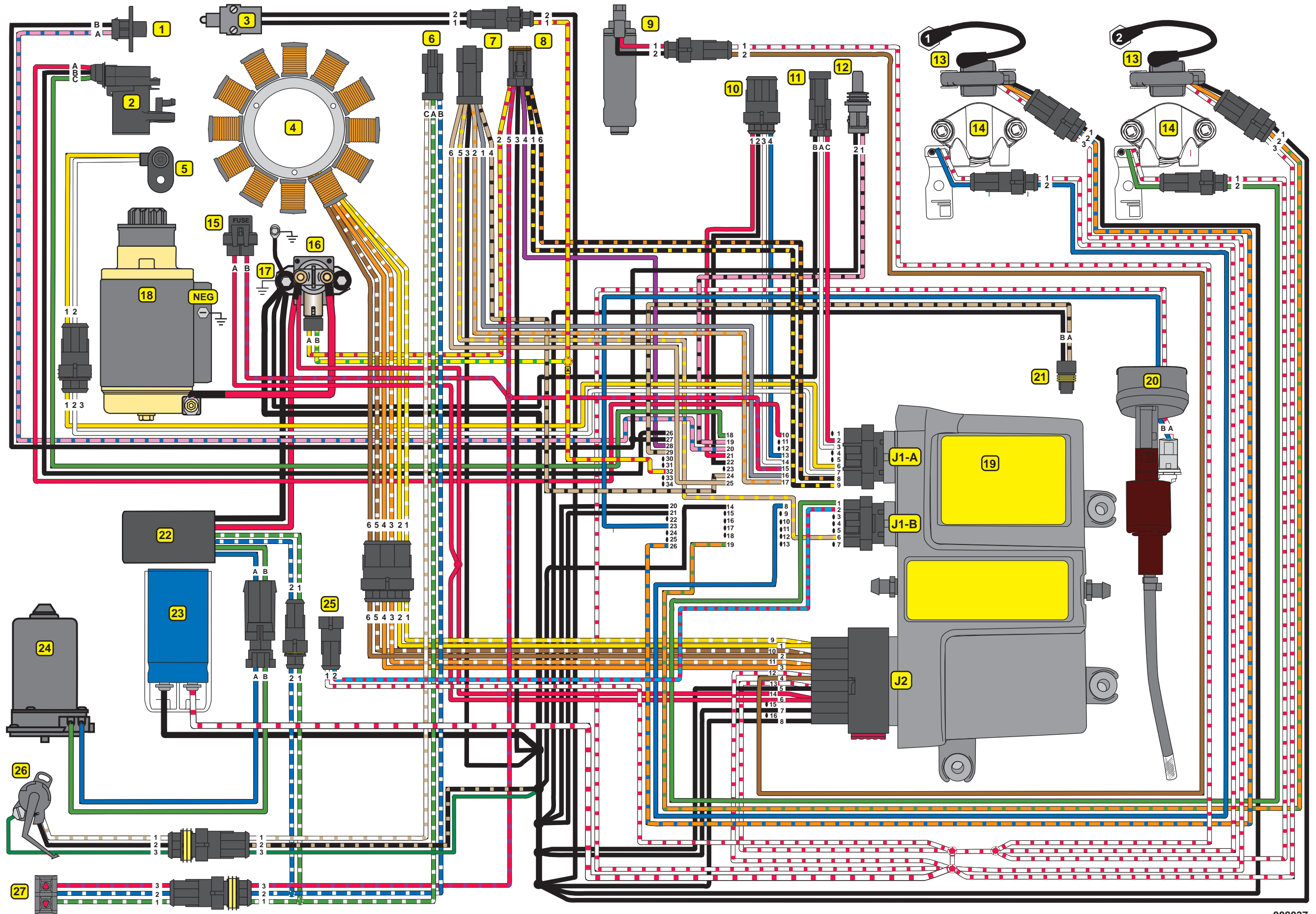



# 75 – 90 HP E-TEC

1. Air Temperature Sensor
2. Throttle Position Sensor
3. Neutral Switch
4. Stator
5. Crankshaft Position Sensor
6. Trim/Tilt Connector
7. SystemCheck Connector
8. Key Switch Connector
9. High Pressure Fuel Pump
10. CANbus Connector
11. Diagnostic Connector
12. Temperature Sensor
13. Ignition Coil
14. Fuel Injector
15. Fuse (10 Amp)
16. Starter Solenoid
17. Main Harness Ground
18. Electric Starter
19. EMM
20. Oil Injector
21. Low Oil Switch
22. Tilt Limit Switch
23. Trim/Tilt Relay Module
24. Capacitor
25. Trim/Tilt Motor
26. Trim Sending Unit
27. Trim/Tilt Switch

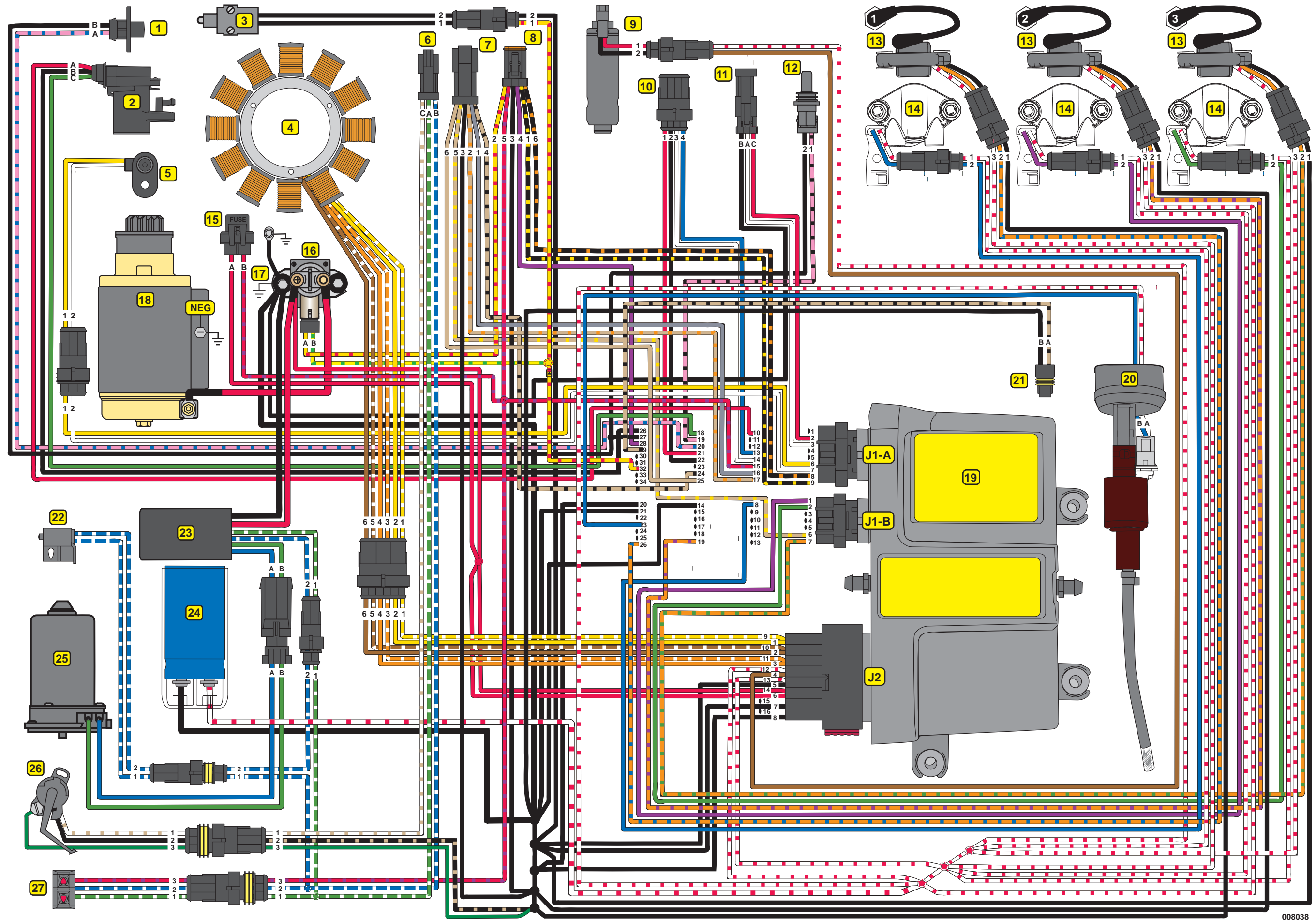





## EVINRUDE 40 – 90 HP EMM SERVICE CODE CHART

CODE	EMM CIRCUIT/SENSOR	INTERNAL SENSOR	S.A.F.E	SHUT DOWN	EMM LED DISPLAY	DASHBOARD GAUGE WARNING DISPLAY	TIME TO ACTIVATE	SENSOR: CIRCUIT VOLTAGE / RESISTANCE (Ω) / INFORMATION
11	Throttle Position Sensor (TPS) out of idle range				-	-	2 seconds	TPS Voltage > 0.78 V with key ON (or cranking). Becomes stored fault when outboard starts. When both hard and stored faults are present, check for improperly adjusted throttle cable.
12	Throttle Position Sensor (TPS) circuit fault				LED 3: OFF (Cranking) / ON (Running)	CHECK ENGINE	0.8 seconds	TPS Voltage: < 0.14 V, or > 4.92 V. Engine limited to idle speed. Check sensor resistance—3000 to 7000 Ω (between pins A and B) & 4000 to 8000 Ω (between pins A and C)
13	TPS below range				LED 3: OFF (Cranking) / ON (Running)	CHECK ENGINE	8 seconds	TPS Voltage < 0.2 V. Check linkage and IDLE stop.
14	TPS above range				LED 3: OFF (Cranking) / ON (Running)	CHECK ENGINE	8 seconds	TPS Voltage > 4.85 V. Check linkage and WOT stop.
15	ROM (EMM program)	✓			-	-	-	ROM "CHECKSUM" failure. Check software program number in EMM. Reload or replace with proper program.
16	Crankshaft Position Sensor (CPS) Intermittent loss of SYNC				LED 2: OFF (Cranking) LED 3: ON (Running)	-	10 instances	EMM counts losses of synchronization with crankshaft sensor. Check CPS mounting and resistance. Air gap range: 00.036 to 0.110 in. (1 to 2.8 mm), nominal 0.073 in. (1.85 mm) Resistance: 560 Ω ± 10% @ 77°F (25°C)
17	55 V circuit BELOW range	✓	✓		LED 1: ON (Running)	CHECK ENGINE	1 minute	System Voltage < 45 V. Engine limited to 1200 RPM. Perform stator/charging tests.
18	55 V circuit ABOVE range	✓	✓		LED 1: ON (Running)	CHECK ENGINE	1 minute	System Voltage > 57 V. Engine limited to 1200 RPM. Perform stator/charging tests. Check for loose connections in 55 V circuit. Check capacitor.
19	Start-in-gear				LED 3: OFF (Cranking)	CHECK ENGINE	-	Attempted engine start while in gear. Engine will not start.
21	Winterization activated				All LEDs FLASHING	All Lights FLASHING	-	Engine is speed limited, and stops after 360 oil pulses. Refer to Maintenance or Operator's Guide.
23	EMM Temperature Sensor circuit fault	✓			LED 3: OFF (Cranking) / ON (Running)	-	8 seconds	EMM Temperature < -71° F (-57.4° C), or > 313° F (156° C).
24	EMM Temperature BELOW range	✓			LED 3: OFF (Cranking) / ON (Running)	-	8 seconds	EMM Temperature < -22° F (-30° C).
25	EMM Temperature ABOVE range	✓	✓		LED 4: ON (Running)	WATER TEMP/HOT	8 seconds	EMM Temperature > 176°F (80°C). Engine limited to 1200 RPM. See Code 29.
26	12 V circuit BELOW range	✓			LED 1: ON (Running)	LOW BATTERY	5 minutes	Battery voltage < 12.5 V. Perform stator/charging tests.
27	12 V circuit ABOVE range	✓			LED 1: ON (Running)	LOW BATTERY	5 minutes	Battery voltage > 15.5 V. Check battery connections and wiring.
29	EMM Temperature OVER range	✓		✓	LED 4: FLASHING	WATER TEMP/HOT (FLASHING)	4 seconds	EMM Temperature > 212° F (100° C). Engine SHUTDOWN. Will NOT restart until EMM temperature returns to operating range. Check outboard and EMM cooling systems.
31	Engine temperature OVER range			✓	LED 4: FLASHING	WATER TEMP/HOT (FLASHING)	8 seconds	2-Cylinder models: Engine Temperature > 248° F (120° C) 3-Cylinder models: Engine Temperature > 212° F (100° C) above 3500 RPM, or 3-Cylinder models: Engine Temperature > 230° F (110° C) below 3500 RPM Engine SHUTDOWN. Check cooling system. Check temperature sensor resistance—9000 to 11000 Ω @ 77°F (25°C).
33	Critical NO OIL detected	✓		✓	LED 4: FLASHING	NO OIL (FLASHING)	3 hours	Outboard has run three hours with code 34 or 117. Engine SHUTDOWN. Will restart and run for 1 minute intervals.
34	Oil injection pump circuit OPEN		✓		LED 4: ON (Running)	NO OIL	4 seconds	Engine limited to 1200 RPM. Check oil injection pump circuit resistance—22 Ω.
40	Engine Temperature ABOVE range—Low speed		✓		LED 4: ON (Running)	WATER TEMP/HOT	8 seconds	3-Cylinder models only. Engine Temperature > 212° F (100° C) below 3500 RPM.
41	Engine Temperature Sensor circuit fault				LED 3: OFF (Cranking) / ON (Running)	-	8 seconds	Engine Temperature < -15° F (-26.2° C), or > 332° F (166.5° C). Check 5 V circuit and ground (NEG), and sensor resistance—9000 to 11000 Ω @ 77°F (25°C).
42	Engine Temperature BELOW range				LED 3: OFF (Cranking) / ON (Running)	-	8 seconds	Engine Temperature < -4° F (-20° C). Check engine temperature and sensor resistance.
43	Engine Temperature ABOVE range		✓		LED 4: ON (Running)	WATER TEMP/HOT	8 seconds	2-Cylinder models: Engine Temperature > 212° F (100° C). 3-Cylinder models: Engine Temperature > 194° F (90° C) above 3500 RPM Engine limited to 1200 RPM. Check cooling system.
44	Barometric Pressure (BP) Sensor circuit fault	✓			-	-	8 seconds	Pressure < 3.9 in. Hg (13.3 kPa), or > 35.1 in. Hg (119.0 kPa). Make sure EMM BP sensor tube is NOT plugged. Check atmospheric condition for comparison. Clear code and retest.
45	BP Sensor BELOW range	✓			-	-	8 seconds	Pressure < 20.7 in. Hg (70 kPa).
46	BP Sensor ABOVE range	✓			-	-	8 seconds	Pressure > 31 in. Hg (105 kPa).

CODE	EMM CIRCUIT/SENSOR	INTERNAL SENSOR	S.A.F.E	SHUT DOWN	EMM LED DISPLAY	DASHBOARD GAUGE WARNING DISPLAY	TIME TO ACTIVATE	SENSOR: CIRCUIT VOLTAGE / RESISTANCE (Ω) / INFORMATION
47	Air Temperature (AT) circuit fault				LED 3: OFF (Cranking) / ON (Running)	CHECK ENGINE	8 seconds	Air temperature < -58° F (-49.9° C), or > 218° F (103.2° C). Check 5 V circuit and ground (NEG), and sensor resistance—9000 to 11000 Ω @ 77°F (25°C).
48	Air Temperature BELOW range				LED 3: OFF (Cranking) / ON (Running)	-	8 seconds	Air temperature < -22° F (-30° C).
49	Air Temperature ABOVE range				LED 3: OFF (Cranking) / ON (Running)	-	8 seconds	Air temperature > 158° F (70° C).
51	Fuel injector circuit #1 OPEN				LED 2: ON (Running)	-	2 seconds	Check injector/circuit resistance—2 to 3 Ω @ 72°F (22°C).
52	Fuel injector circuit #2 OPEN				LED 2: ON (Running)	-	2 seconds	
53	Fuel injector circuit #3 OPEN				LED 2: ON (Running)	-	2 seconds	
57	High RPM with low TPS setting	✓		✓	LED 3: FLASHING	CHECK ENGINE (FLASHING)	10 seconds	TPS < 5% and RPM > 3000. Engine SHUTDOWN. Will NOT restart until code has been cleared. The problem could be caused by uncontrolled fuel entering the engine. DO NOT attempt to start the outboard until the problem has been found and repaired.
58	Operating temperature not reached				LED 3: OFF (Cranking) / ON (Running)	-	10 minutes	Engine temperature < 104° F (40° C) with engine speed < 2300 RPM. Check thermostat and pressure relief valve.
61	Fuel injector circuit #1 SHORTED				LED 2: ON (Running)	-	8 seconds	Check injector/circuit resistance—2 to 3 Ω @ 72°F (22°C).
62	Fuel injector circuit #2 SHORTED				LED 2: ON (Running)	-	8 seconds	
63	Fuel injector circuit #3 SHORTED				LED 2: ON (Running)	-	8 seconds	
78	Sensor supply voltage fault	✓			LED 3: OFF (Cranking) / ON (Running)	-	10 seconds	Sensor voltage < 4.75 V. Check sensors and related wiring. Check for pinched or chafed wiring.
81	Ignition timing circuit #1 OPEN				LED 2: ON (Running)	-	10 instances	EMM counts failed ignition events. Check wiring. Test with known good ignition coil.
82	Ignition timing circuit #2 OPEN				LED 2: ON (Running)	-	10 instances	
83	Ignition timing circuit #3 OPEN				LED 2: ON (Running)	-	10 instances	
90	Water injection solenoid SHORTED				LED 2: ON (Running)	-	8 seconds	Check circuit resistance—295 Ω ± 20 @ 77°F (25°C).
91	Fuel pump circuit OPEN				LED 2: ON (Running)	-	8 seconds	Check pump/circuit resistance—2 to 3 Ω @ 77°F (25°C).
93	Water injection solenoid OPEN				LED 2: ON (Running)	-	8 seconds	Check circuit resistance—295 Ω ± 20 @ 77°F (25°C).
94	Fuel pump circuit SHORTED				LED 2: ON (Running)	-	2 seconds	Check pump/circuit resistance—2 to 3 Ω @ 77°F (25°C).
101	Ignition timing circuit #1 SHORTED				LED 2: ON (Running)	-	20 instances	EMM counts failed ignition events. Check wiring. Test with known good ignition coil.
102	Ignition timing circuit #2 SHORTED				LED 2: ON (Running)	-	20 instances	
103	Ignition timing circuit #3 SHORTED				LED 2: ON (Running)	-	20 instances	
117	Critical LOW OIL detected	✓	✓		LED 4: ON (Running)	NO OIL	4800 Pulses (2-Cyl) 6000 Pulses (3-Cyl)	EMM counts oil pump pulses after LOW OIL switch closes. Engine limited to 1200 RPM. Stop outboard and add oil to tank. Warning resets after three oil pump pulses.

NOTE: Always note service codes before clearing codes. Clear stored codes using diagnostic software. Clearing some codes requires turning EMM "OFF" and then "ON" again.



