

**EVINRUDE**<sup>®</sup>  
E-TEC<sup>®</sup>



## 2011 Service Manual

**15, 25, 30 HP**



---

BRP US Inc.  
Technical Publications  
250 Sea Horse Drive  
Waukegan, Illinois 60085 United States



- † AMP, Superseal 1.5, Super Seal, Power Timer, and Pro-Crimper II are registered trademarks of Tyco International, Ltd.
- † Amphenol is a registered trademark of The Amphenol Corporation.
- † BEP is a registered trademark of Actuant Corporation.
- † Champion is a registered trademark of Federal-Mogul Corporation.
- † Deutsch is a registered trademark of The Deutsch Company.
- † Dexron is a registered trademark of The General Motors Corporation.
- † Fluke is a registered trademark of The Fluke Corporation
- † GE is a registered trademark of The General Electric Company.
- † GM is a registered trademark of The General Motors Corporation.
- † Loctite and Loctite are registered trademarks of The Henkel Group.
- † Lubriplate is a registered trademark of Fiske Brothers Refining Company.
- † NMEA is a registered trademark of the National Marine Electronics Association.
- † Oetiker is a registered trademark of Hans Oetiker AG Maschinen.
- † Packard is a registered trademark of Delphi Automotive Systems.
- † Permatex is a registered trademark of Permatex.
- † STP is a registered trademark of STP Products Company.
- † Snap-on is a registered trademark of Snap-on Technologies, Inc.

**The following trademarks are the property of BRP US Inc. or its affiliates:**

<i>Evinrude</i> ®	<i>Twist Grip</i> ™
<i>Johnson</i> ®	<i>Nut Lock</i> ™
<i>Evinrude</i> ® <i>E-TEC</i> ®	<i>Screw Lock</i> ™
<i>FasTrak</i> ™	<i>Ultra Lock</i> ™
<i>S.A.F.E.</i> ™	<i>Moly Lube</i> ™
<i>SystemCheck</i> ™	<i>Triple-Guard</i> ® Grease
<i>I-Command</i> ™	<i>DPL</i> ™ Lubricant
<i>Evinrude</i> ® <i>ICON</i> ™	<i>2+4</i> ® Fuel Conditioner
<i>Evinrude</i> ® / <i>Johnson</i> ® <i>XD30</i> ™ Outboard Oil	<i>Carbon Guard</i> ™
<i>Evinrude</i> ® / <i>Johnson</i> ® <i>XD50</i> ™ Outboard Oil	<i>HPF XR</i> ™ Gearcase Lubricant
<i>Evinrude</i> ® / <i>Johnson</i> ® <i>XD100</i> ™ Outboard Oil	<i>HPF PRO</i> ™ Gearcase Lubricant
<i>Gel-Seal II</i> ™	

---

---

# SERVICE MANUAL CONTENTS

SECTION .....	PAGE
1 REFERENCE INFORMATION .....	3
2 ROUTINE SERVICE .....	13
3 ENGINE COVER SERVICE .....	43
4 ENGINE MANAGEMENT MODULE (EMM) .....	49
5 SYSTEM ANALYSIS .....	67
6 ELECTRICAL AND IGNITION .....	81
7 FUEL SYSTEM .....	115
8 OILING SYSTEM .....	141
9 COOLING SYSTEM .....	157
10 POWERHEAD .....	167
11 MIDSECTION .....	197
12 GEARCASE .....	243
13 TRIM AND TILT .....	267
14 MANUAL STARTER .....	279
SAFETY .....	S-1
INDEX .....	I-1
TROUBLE CHECK CHART .....	T-1
DIAGRAMS	

**IMPORTANT:** For complete outboard rigging and control installation information, refer to the **Predelivery and Installation Guide** included with the service manual set.

All special tools referenced in this manual can be found in the **Special Tools Guide**, P/N 5008526.



# REFERENCE INFORMATION

## TABLE OF CONTENTS

**SAFETY NOTICE** .....4  
**ABBREVIATIONS USED IN THIS MANUAL** .....6  
    **UNITS OF MEASUREMENT** .....6  
    **LIST OF ABBREVIATIONS** .....6  
**EMISSION-RELATED INSTALLATION INSTRUCTIONS** .....7  
    **MANUFACTURER’S RESPONSIBILITY** .....7  
    **DEALER’S RESPONSIBILITY** .....7  
    **OWNER’S RESPONSIBILITY** .....7  
    **EPA EMISSION REGULATIONS** .....7  
**MODEL DESIGNATION** .....8  
**MODELS COVERED IN THIS MANUAL** .....9  
**SERVICE SPECIFICATIONS** .....10  
**STANDARD TORQUE SPECIFICATIONS** .....12  
**PRODUCT REFERENCE AND ILLUSTRATIONS** .....12

---

---

# SAFETY NOTICE

Before working on any part of the outboard, read the **SAFETY** section at the end of this manual.

This publication is written for qualified, factory-trained technicians who are already familiar with the use of *Evinrude/Johnson* Special Tools. The included information is not a substitute for work experience. It is an organized guide for reference, repair, and/or maintenance.

The following symbols and/or signal words may be used in this document:

 **DANGER**

Indicates a hazardous situation which, if not avoided, will result in death or serious injury.

 **WARNING**

Indicates a hazardous situation which, if not avoided, could result in death or serious injury

 **CAUTION**

Indicates a hazardous situation which, if not avoided, could result in minor or moderate personal injury.

**NOTICE** Indicates an instruction which, if not followed, could severely damage engine components or other property.

These safety alert signal words mean:

ATTENTION!  
BECOME ALERT!  
YOUR SAFETY IS INVOLVED!

**IMPORTANT:** Identifies information that controls correct assembly and operation of the product.

DO NOT perform any work until you have read and understood these instructions completely.

Torque wrench tightening specifications must strictly be adhered to.

Should removal of any locking fastener (lock tabs, locknuts, or patch screws) be required, always replace with a new one.

When replacement parts are required, use *Evinrude/Johnson Genuine Parts* or parts with equivalent characteristics, including type, strength and material. Use of substandard parts could result in injury or product malfunction.

Always wear EYE PROTECTION AND APPROPRIATE GLOVES when using power tools.

Unless otherwise specified, engine must be OFF when performing this work.

Always be aware of parts that can move, such as flywheels, propellers, etc.

Some components may be HOT. Always wait for engine to cool down before performing work.

If you use procedures or service tools that are not recommended in this manual, YOU ALONE must decide if your actions might injure people or damage the outboard.

This document may be translated into other languages. In the event of any discrepancy, the English version shall prevail.

**DANGER**

Contact with a rotating propeller is likely to result in serious injury or death. Assure the engine and prop area is clear of people and objects before starting engine or operating boat. Do not allow anyone near a propeller, even when the engine is off. Blades can be sharp and the propeller can continue to turn even after the engine is off. Remove propeller before servicing and when running the outboard on a flushing device.

**DO NOT** run the engine indoors or without adequate ventilation or permit exhaust fumes to accumulate in confined areas. Engine exhaust contains carbon monoxide which, if inhaled, can cause serious brain damage or death.

**WARNING**

Wear safety glasses to avoid personal injury, and set compressed air to less than 25 psi (172 kPa).

The motor cover and flywheel cover are machinery guards. Use caution when conducting tests on running outboards. **DO NOT** wear jewelry or loose clothing. Keep hair, hands, and clothing away from rotating parts.

During service, the outboard may drop unexpectedly. Avoid personal injury; always support the outboard's weight with a suitable hoist or the tilt support bracket during service.

To prevent accidental starting while servicing, disconnect the battery cables at the battery. Twist and remove all spark plug leads.

The electrical system presents a serious shock hazard. **DO NOT** handle primary or secondary ignition components while outboard is running or flywheel is turning.

Gasoline is extremely flammable and highly explosive under certain conditions. Use caution when working on any part of the fuel system.

Protect against hazardous fuel spray. Before starting any fuel system service, carefully relieve fuel system pressure.

Do not smoke, or allow open flames or sparks, or use electrical devices such as cellular phones in the vicinity of a fuel leak or while fueling.

Keep all electrical connections clean, tight, and insulated to prevent shorting or arcing and causing an explosion.

Always work in a well ventilated area.

Replace any locking fastener (locknut or patch screw) if its locking feature becomes weak. Definite resistance to tightening must be felt when reusing a locking fastener. If replacement is indicated, use only authorized replacement or equivalent.

# ABBREVIATIONS USED IN THIS MANUAL

## Units of Measurement

A	Amperes
amp-hr	Ampere hour
fl. oz.	fluid ounce
ft. lbs.	foot pounds
HP	horsepower
in.	inch
in. Hg	inches of mercury
in. lbs.	inch pounds
kPa	kilopascals
ml	milliliter
mm	millimeter
N·m	Newton meter
P/N	part number
psi	pounds per square inch
RPM	revolutions per minute
°C	degrees Celsius
°F	degrees Fahrenheit
ms	milliseconds
µs	microseconds
Ω	Ohms
V	Volts
VAC	Volts Alternating Current
VDC	Volts Direct Current

## List of Abbreviations

ABYC	American Boat & Yacht Council
ATDC	after top dead center
AT	air temperature sensor
BPS	barometric pressure sensor
BTDC	before top dead center
CCA	cold cranking amps
CFR	Code of Federal Regulations
CPS	crankshaft position sensor
<i>EMM</i>	Engine Management Module
EPA	Environmental Protection Agency
ICOMIA	International Council of Marine Industry Associations
ID	Inside dimension
MCA	marine cranking amps
MWS	modular wiring system
NMEA	National Marine Electronics Assoc.
ROM	read only memory
S.A.F.E.	speed adjusting failsafe electronics
SAC	start assist circuit
SAE	Society of Automotive Engineers
SYNC	synchronization
TDC	top dead center
TPS	throttle position sensor
USCG	United States Coast Guard
WOT	wide open throttle
WTS	water temperature sensor



# EMISSION-RELATED INSTALLATION INSTRUCTIONS

**Failing to follow these instructions when installing a certified engine in a vessel violates federal law (40 CFR 1068.105 (b)), subject to fines or other penalties as described in the Clean Air Act.**

Maintenance, replacement, or repair of the emission control devices and systems may be performed by any marine SI (spark ignition) engine repair establishment or individual.

## Manufacturer's Responsibility

Beginning with 1999 model year outboards, manufacturers of marine outboards must determine the exhaust emission levels for each outboard horsepower family and certify these outboards with the United States of America Environmental Protection Agency (EPA). An emissions control information label, showing emission levels and outboard specifications, must be placed on each outboard at the time of manufacture.

## Dealer's Responsibility

When performing service on all 1999 and more recent *Evinrude/Johnson* outboards that carry an emissions control information label, adjustments must be kept within published factory specifications.

Replacement or repair of any emission related component must be executed in a manner that maintains emission levels within the prescribed certification standards.

Dealers are not to modify the outboard in any manner that would alter the horsepower or allow emission levels to exceed their predetermined factory specifications.

Exceptions include manufacturer's prescribed changes, such as altitude adjustments, for example.

## Owner's Responsibility

The owner/operator is required to have outboard maintenance performed to maintain emission levels within prescribed certification standards.

The owner/operator is not to, and should not allow anyone to, modify the outboard in any manner that would alter the horsepower or allow emissions levels to exceed their predetermined factory specifications.

Tampering with the fuel system to change horsepower or modify emission levels beyond factory settings or specifications will void the product warranty.

## EPA Emission Regulations

All new 1999 and more recent *Evinrude/Johnson* outboards are certified to the EPA as conforming to the requirements of the regulations for the control of air pollution from new watercraft marine spark ignition outboards. This certification is contingent on certain adjustments being set to factory standards. For this reason, the factory procedure for servicing the product must be strictly followed and, whenever practical, returned to the original intent of the design. The responsibilities listed above are general and in no way a complete listing of the rules and regulations pertaining to the EPA requirements on exhaust emissions for marine products. For more detailed information on this subject, you may contact the following locations:

### VIA U.S. POSTAL SERVICE:

Office of Mobile Sources  
Engine Programs and Compliance Division  
Engine Compliance Programs Group (6403J)  
401 M St. NW  
Washington, DC 20460

### VIA EXPRESS or COURIER MAIL:

Office of Mobile Sources  
Engine Programs and Compliance Division  
Engine Compliance Programs Group (6403J)  
501 3rd St. NW  
Washington, DC 20001

### EPA INTERNET WEB SITE:

[www.epa.gov](http://www.epa.gov)

**REFERENCE INFORMATION**  
**MODEL DESIGNATION**

**MODEL DESIGNATION**

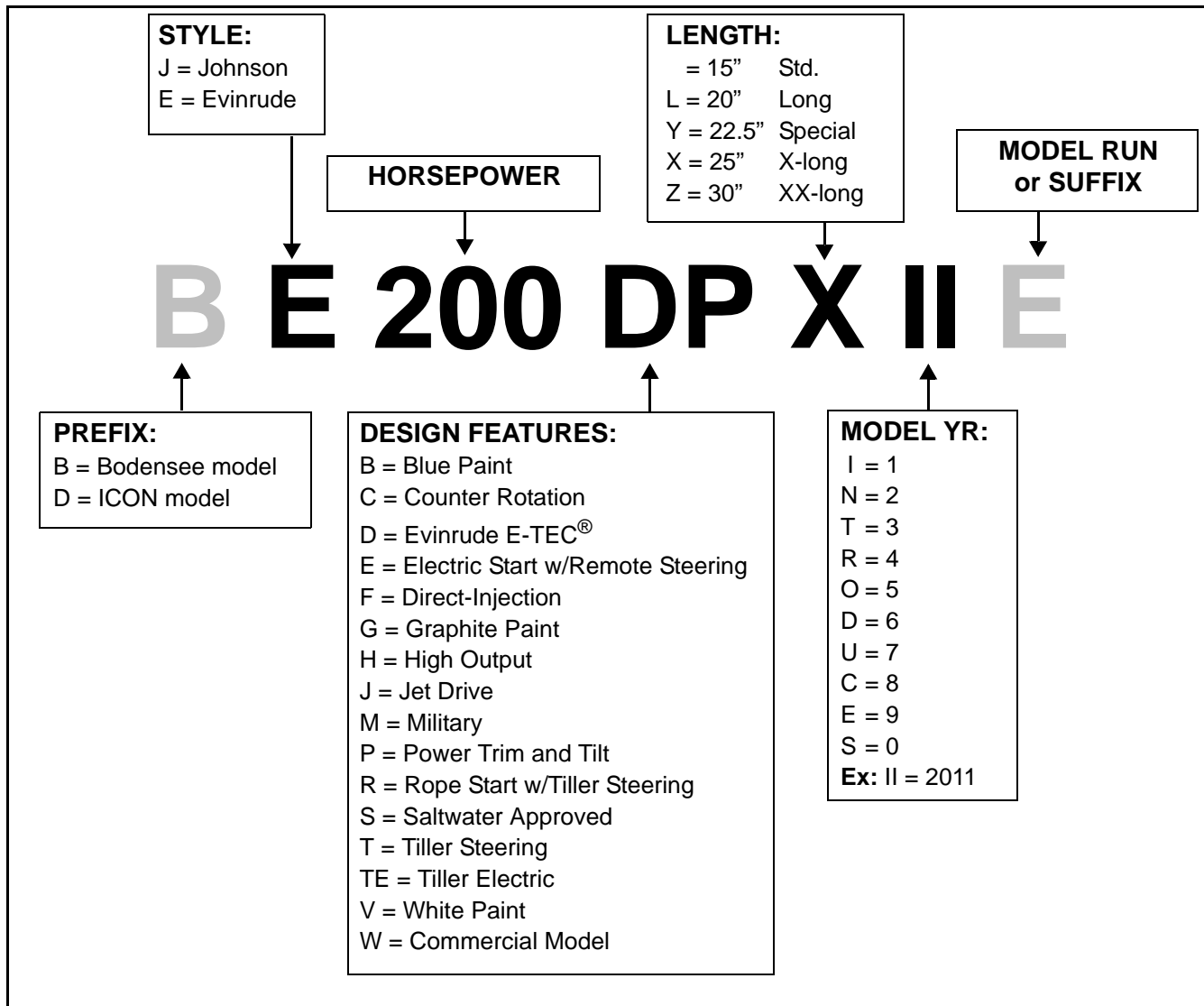

Model and serial numbers are located on the swivel bracket and on the powerhead.



1. Model and serial number

007445



1. Serial number

007446

## MODELS COVERED IN THIS MANUAL

This manual covers service information on all 35.1 cubic inch (.57 L), 2-Cylinder *Evinrude E-TEC* models.

<i>Model</i>	<i>Displacement</i>	<i>Gearcase</i>	<i>Height</i>	<i>Color</i>	<i>Description</i>
E15DHPLII_	.57 L, 35.1 ci	13:28 / 0.46 H	20"	Blue	Power Tilt, Remote Steering, Electric Start
E15HPSLII_	.57 L, 35.1 ci	13:28 / 0.46 H	20"	White	Power Tilt, Remote Steering, Electric Start
E15DHTLII_	.57 L, 35.1 ci	13:28 / 0.46 H	20"	Blue	Power Tilt, Tiller Steering, Electric Start, Touch Troll
E15HTSLII_	.57 L, 35.1 ci	13:28 / 0.46 H	20"	White	Power Tilt, Tiller Steering, Electric Start, Touch Troll
E15HPSXII_	.57 L, 35.1 ci	13:28 / 0.46 H	25"	White	Power Tilt, Remote Steering, Electric Start
E15HTSXII_	.57 L, 35.1 ci	13:28 / 0.46 H	25"	White	Power Tilt, Tiller Steering, Electric Start, Touch Troll
E25DRII_	.57 L, 35.1 ci	13:28 / 0.46 H	15"	Blue	Manual Tilt, Tiller Steering, Rope Start, Touch Troll
E25DRSII_	.57 L, 35.1 ci	13:28 / 0.46 H	15"	White	Manual Tilt, Tiller Steering, Rope Start, Touch Troll
E25DTEII_	.57 L, 35.1 ci	13:28 / 0.46 H	15"	Blue	Manual Tilt, Tiller Steering, Electric Start, Touch Troll
E25DRLII_	.57 L, 35.1 ci	13:28 / 0.46 H	20"	Blue	Manual Tilt, Tiller Steering, Rope Start, Touch Troll
E25DRSLII_	.57 L, 35.1 ci	13:28 / 0.46 H	20"	White	Manual Tilt, Tiller Steering, Rope Start, Touch Troll
E25DTLII_	.57 L, 35.1 ci	13:28 / 0.46 H	20"	Blue	Manual Tilt, Tiller Steering, Electric Start, Touch Troll
E25TESLII_	.57 L, 35.1 ci	13:28 / 0.46 H	20"	White	Manual Tilt, Tiller Steering, Electric Start, Touch Troll
E25DELII_	.57 L, 35.1 ci	13:28 / 0.46 H	20"	Blue	Manual Tilt, Remote Steering, Electric Start
E25DPLII_	.57 L, 35.1 ci	13:28 / 0.46 H	20"	Blue	Power Tilt, Remote Steering, Electric Start
E25DPSLII_	.57 L, 35.1 ci	13:28 / 0.46 H	20"	White	Power Tilt, Remote Steering, Electric Start
E25DTLII_	.57 L, 35.1 ci	13:28 / 0.46 H	20"	Blue	Power Tilt, Tiller Steering, Electric Start, Touch Troll
E25DTSLII_	.57 L, 35.1 ci	13:28 / 0.46 H	20"	White	Power Tilt, Tiller Steering, Electric Start, Touch Troll
E30DRII_	.57 L, 35.1 ci	13:28 / 0.46 H	15"	Blue	Manual Tilt, Tiller Steering, Rope Start, Touch Troll
E30DRSII_	.57 L, 35.1 ci	13:28 / 0.46 H	15"	White	Manual Tilt, Tiller Steering, Rope Start, Touch Troll
E30DPLII_	.57 L, 35.1 ci	13:28 / 0.46 H	20"	Blue	Power Tilt, Remote Steering, Electric Start
E30DPSLII_	.57 L, 35.1 ci	13:28 / 0.46 H	20"	White	Power Tilt, Remote Steering, Electric Start
E30DELII_	.57 L, 35.1 ci	13:28 / 0.46 H	20"	Blue	Manual Tilt, Remote Steering, Electric Start
E30DRLII_	.57 L, 35.1 ci	13:28 / 0.46 H	20"	Blue	Manual Tilt, Tiller Steering, Rope Start, Touch Troll
E30DRSLII_	.57 L, 35.1 ci	13:28 / 0.46 H	20"	White	Manual Tilt, Tiller Steering, Rope Start, Touch Troll
E30DTLII_	.57 L, 35.1 ci	13:28 / 0.46 H	20"	Blue	Power Tilt, Tiller Steering, Electric Start, Touch Troll
E30DTSLII_	.57 L, 35.1 ci	13:28 / 0.46 H	20"	White	Power Tilt, Tiller Steering, Electric Start, Touch Troll
E30DTLII_	.57 L, 35.1 ci	13:28 / 0.46 H	20"	Blue	Manual Tilt, Tiller Steering, Electric Start, Touch Troll
E30TESLII_	.57 L, 35.1 ci	13:28 / 0.46 H	20"	White	Manual Tilt, Tiller Steering, Electric Start, Touch Troll

**REFERENCE INFORMATION**  
**SERVICE SPECIFICATIONS**

**SERVICE SPECIFICATIONS**

		<b>15 HO Models</b>	<b>25 – 30 HP Models</b>
<b>ENGINE</b>	Full Throttle Operating Range RPM	15 HP – 5500 to 6100 RPM	25 HP – 5500 to 6100 RPM 30 HP – 5500 to 6100 RPM
	Power	15 HP (11.2 kw) @ 5800 RPM	25 HP (30 kw) @ 5800 RPM 30 HP (37 kw) @ 5800 RPM
	Idle RPM in Gear	750 ± 50 <i>EMM</i> Controlled	
	Idle RPM in Neutral	700 ± 50 <i>EMM</i> Controlled	
	Weight (may vary depending on model)	<b>(DHPL) Models:</b> 181 lbs. (82 Kg) <b>(DHTL) Models:</b> 187 lbs. (85 Kg)	<b>(R) Models:</b> 152 lbs. (69 kg) <b>(RL) Models:</b> 156 lbs. (71 kg) <b>(TE) Models:</b> 166 lbs. (105 kg) <b>(TEL) Models:</b> 170 lbs. (75 kg) <b>(DTL) Models:</b> 191 lbs. (86 kg) <b>(DEL) Models:</b> 164 lbs. (74 kg) <b>(PL) Models:</b> 185 lbs. (84 kg)
	Lubrication	<i>Evinrude/Johnson XD100, XD50, XD30; or</i> NMMA TC-W3 certified	
	Engine Type	In-line, 2 Cylinder, Two-Cycle	
	Displacement	35.1 cu. in. (575 cc)	
	Bore	2.992 in (76 mm)	
	Stroke	2.500 in. (63.50 mm)	
	Standard Bore	2.9916 to 2.9931 in. (75.989 to 76.026 mm) To bore oversize, add piston oversize dimension to standard bore	
	Top Crankshaft Journal	1.6235 to 1.6245 in. (41.237 to 41.262 mm)	
	Center Crankshaft Journal	1.7461 to 1.7470 in. (44.350 to 44.375 mm)	
	Bottom Crankshaft Journal	2.0450 to 2.0459 in. (51.942 to 51.967 mm)	
	Rod Crankpin	1.1815 to 1.1817 in. (30.011 to 30.016 mm)	
	Piston Ring End Gap, Both	0.011 to 0.019 in. (0.30 to 0.50 mm)	
<b>FUEL</b>	Fuel/Oil Control	<i>EMM</i> Controlled	
	Starting Enrichment	<i>EMM</i> Controlled	
	Minimum (High) Fuel Pressure	28 to 32 psi (193 to 220 kPa)	
	Minimum Fuel Lift Pump Pressure	2 psi (14 kPa)	
	Maximum Fuel Inlet Vacuum	4 in. Hg.	
	Minimum Octane	87 AKI (R+M)/2 or 90 RON	
	Additives	2+4 <sup>®</sup> <i>Fuel Conditioner, Fuel System Cleaner</i> Use of other additives may result in engine damage. See <b>FUEL SYSTEM REQUIREMENTS</b> on p. 120 for additional information	



**REFERENCE INFORMATION**  
**SERVICE SPECIFICATIONS**

1

		15 HO Models	25 – 30 HP Models
<b>ELECTRICAL</b>	Minimum Battery Requirements	640 CCA (800 MCA) <b>or</b> 800 CCA (1000 MCA) below 32° F (0° C)	
	Alternator	15-Amp fully regulated Refer to <b>Predelivery and Installation Guide</b> for multiple battery applications.	
	Tachometer Setting	6 pulse (12 pole)	
	Engine Fuse	P/N 967545 – 10 A	
<b>COOLING</b>	Thermostat	143°F (62°C)	
	Maximum Temperature	212°F (100°C)	
<b>IGNITION</b>	Type	IDI Inductive Ignition	
	Firing Order	1-2	
	Ignition Timing	<i>EMM</i> Controlled	
	RPM Limit in Gear	6250	
	RPM Limit in Neutral	1100	
	Crankshaft Position Sensor Air Gap	Fixed	
	Spark Plug	Refer to Emission Control Information Label <i>Champion</i> <sup>†</sup> QC10WEP @ 0.028 ± 0.003 in. (0.71 mm)	
<b>GEARCASE</b>	Gear Ratio	13:28 (.465)	
	Lubricant	<i>HPF XR Gearcase Lube</i> <i>HPF Pro</i> in high performance or commercial applications	
	Capacity	11 fl. oz. (325 ml)	
	Shift Rod Height	fixed	
	Shift Cable Stroke	1.125 to 1.330 in. (28.6 to 33.8 mm) measured between NEUTRAL and FORWARD	
<b>POWER TRIM/TILT</b>	Lubrication	<i>Evinrude/Johnson</i> Biodegradable TNT Fluid	
	Fluid Capacity	11.7 fl. oz. (346 ml)	
	Trim Range	0° to 15°	
	Tilt Range	16° to 65°	

**REFERENCE INFORMATION**  
**STANDARD TORQUE SPECIFICATIONS**

**STANDARD TORQUE SPECIFICATIONS**

Size	In. Lbs.	Ft. Lbs.	N·m
No. 6	7–10	0.58–0.83	0.8–1.1
No. 8	15–22	1.25–1.83	1.7–2.5
No. 10	24–36	2–3	2.7–4.0
No. 12	36–48	3–4	4.0–5.4
1/4 in.	60–84	5–7	7–9.5
5/16 in.	120–144	10–12	13.5–16.5
3/8 in.	216–240	18–20	24.5–27
7/16 in.	336–384	28–32	38–43.5
M3	15–22	1.25–1.83	1.7–2.5
M4	24–35	2–2.9	2.7–4.0
M5	35–60	2.9–5	4.0–6.8
M6	84–106	7–8.8	9.5–12
M8	177–204	14.7–17	20–23
M10	310–336	25.8–28	35–38

**IMPORTANT:** These values apply only when a specific torque for a specific fastener is not listed in the appropriate section. When tightening two or more screws on the same part, **DO NOT** tighten screws completely, one at a time.

**⚠ WARNING**

Torque wrench tightening specifications must be strictly adhered to. Replace any locking fastener (locknut or patch screw) if its locking feature becomes weak. Definite resistance to turning must be felt when reusing a locking fastener.

If replacement is specified or required because the locking fastener has become weak, use only authorized *Evinrude/Johnson Genuine Parts*.

**PRODUCT REFERENCE AND ILLUSTRATIONS**

*BRP US Inc.* reserves the right to make changes at any time, without notice, in specifications and models and also to discontinue models. The right is also reserved to change any specifications or parts, at any time, without incurring any obligation to equip same on models manufactured prior to date of such change. Specifications used are based on the latest product information available at the time of publication.

The continuing accuracy of this manual cannot be guaranteed.

All photographs and illustrations used in this manual may not depict actual models or equipment, but are intended as representative views for reference only.

Certain features or systems discussed in this manual might not be found on all models in all marketing areas.

All service technicians must be familiar with nautical orientation. This manual often identifies parts and procedures using these terms.

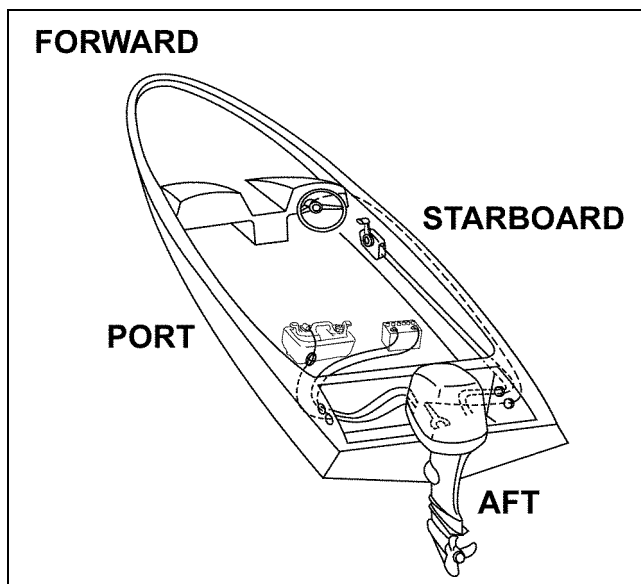

Nautical Orientation

006411

# ROUTINE SERVICE

## TABLE OF CONTENTS

INSPECTION AND MAINTENANCE SCHEDULE .....	14
LIFTING THE OUTBOARD .....	15
OUTBOARD RIGGING CONNECTIONS .....	17
CONTROL CABLE INSTALLATION .....	18
SYSTEMCHECK HARNESS CONNECTIONS .....	20
BATTERY AND BATTERY CONNECTIONS .....	21
<i>OETIKER</i> CLAMP SERVICING .....	22
ADJUSTMENTS .....	24
STEERING FRICTION ADJUSTMENT .....	24
THROTTLE FRICTION ADJUSTMENT .....	24
TILLER HEIGHT ADJUSTMENT .....	25
TILLER HANDLE RATCHET .....	25
TILLER HANDLE FRICTION .....	25
NEUTRAL SWITCH ADJUSTMENT .....	25
TRIM SENDING UNIT ADJUSTMENT .....	26
TRIM TAB ADJUSTMENT .....	27
OPERATIONAL CHECKS .....	28
COOLING SYSTEM .....	29
WATER INTAKE SCREENS .....	29
ENGINE FLUSHING .....	30
RUNNING THE OUTBOARD USING A HOSE AND FLUSHING ADAPTER .....	31
LUBRICATION .....	32
STEERING SYSTEM .....	32
TILLER HANDLE .....	32
SWIVEL BRACKET AND TRAILERING BRACKET .....	32
TILT TUBE .....	32
THROTTLE AND SHIFT LINKAGE .....	33
PROPELLER SHAFT .....	33
GEARCASE LUBRICANT .....	34
TRIM AND TILT .....	35
SPARK PLUGS .....	36
INDEXING .....	36
FUEL AND OIL SYSTEMS .....	37
FUEL FILTER .....	37
OIL FILTERS AND OIL RESERVOIR .....	37
AIR SILENCER .....	37
HOSES AND CONNECTIONS .....	37
ANTI-CORROSION PROTECTION .....	38
STORAGE .....	39
FUEL SYSTEM TREATMENT .....	39
INTERNAL ENGINE TREATMENT .....	39
ADDITIONAL RECOMMENDATIONS .....	40
PRE-SEASON SERVICE .....	40
SUBMERGED ENGINES .....	41

**ROUTINE SERVICE**  
INSPECTION AND MAINTENANCE SCHEDULE

# INSPECTION AND MAINTENANCE SCHEDULE

Routine inspection and maintenance is necessary to prolong outboard life. The following chart provides guidelines for inspection and maintenance to be performed by an authorized Dealer.

**IMPORTANT:** Outboards used in rental, commercial, or other high hour applications require more frequent inspections and maintenance. Adjust schedule for operating and environmental conditions.

Description	Engine Care Product	Routine Inspection	Every 300 hours or every three years <sup>(1)</sup>
Emergency stop circuit and lanyard, check operation		✓	
Controls, steering and tilting; check operation		✓	
Engine mounting hardware, re-tighten		✓	
Fasteners, tighten any loosened components		✓	
Water intake screens, check condition		✓	
Cooling system; check water pump indicator		✓	
Anticorrosion anodes, check condition		✓	
Gearcase, check condition		✓	
Propeller, check condition		✓	
Fuel and oil systems, inspect and repair leaks <sup>(2)</sup>		✓	
Check battery connections and condition		✓	
Access <i>EMM</i> information, resolve any service codes			✓
Electrical and ignition wires, inspect for wear or chafing			✓
Fuel filter, replace			✓
Gearcase lubricant, replace	A		✓
Spark plugs, inspect or replace <sup>(2)</sup>			✓
Thermostats, inspect and check operation <sup>(2)</sup>			✓
Grease fittings, lubricate <sup>(3)</sup>	C		✓
Power trim/tilt and fluid level, inspect	B		✓
Propeller shaft splines, inspect and lubricate <sup>(3)</sup>	C		✓
Starter pinion shaft, inspect and lubricate <sup>(3)</sup>	D		✓
Control cables, inspect and adjust			✓
Steering cable, inspect and lubricate	C		✓
Water pump, inspect / replace (more often if water pressure loss or overheating occurs)			✓

(1) Average recreational use. Commercial use, heavy use, or use in salt or polluted water requires more frequent inspection and maintenance.

(2) Emission-related component

(3) Annually in salt water applications

- A *HPF Pro* Gearcase Lubricant
- B Biodegradable TNT Fluid (Single ram hydraulic systems)
- C *Triple-Guard* Grease
- D Starter Bendix Lube Only



# LIFTING THE OUTBOARD

**⚠ WARNING**

To avoid personal injury, make sure the lifting capacity of the hoist is at least twice the weight of the outboard.

**DO NOT** allow the lift hook or chain from the hoist to come in contact with any part of the engine during lifting.

Remove shipping carton.

Use correct Lifting Fixture to lift outboard:

Model	Lifting Fixture
15–30 HP	P/N 354717

Install Lifting Tool, P/N 354717, on both sides of the tilt tube.

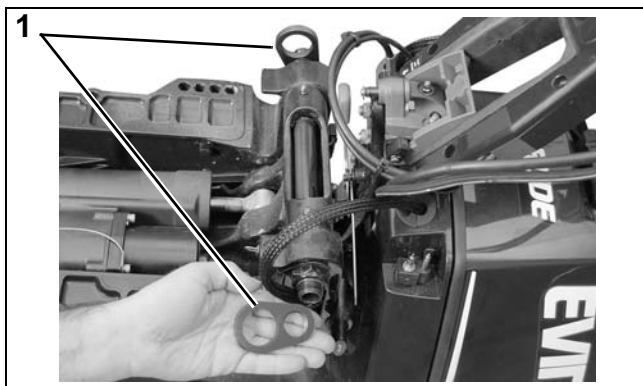

1. Lifting tool, P/N 354717

007122

**⚠ WARNING**

To avoid personal injury or outboard damage, be sure the lifting tool is fully threaded on both sides of the tilt tube.

Use an appropriate chain, at least 36 inches (91 mm) long with two snap hooks, each capable of lifting 500 lbs. (227 kg).

Attach hooks to lifting device and attach chain to hoist.

**⚠ WARNING**

Use this tool for horizontal lifting of 30 HP and smaller *Evinrude E-TEC* models **ONLY**.

**DO NOT** use this tool to lift outboards larger than 30 HP *Evinrude E-TEC* models.

To avoid personal injury and boat or outboard damage, **DO NOT** use this tool to install or remove outboard from transom as outboard can unexpectedly tip.

Lift the engine out of the carton.

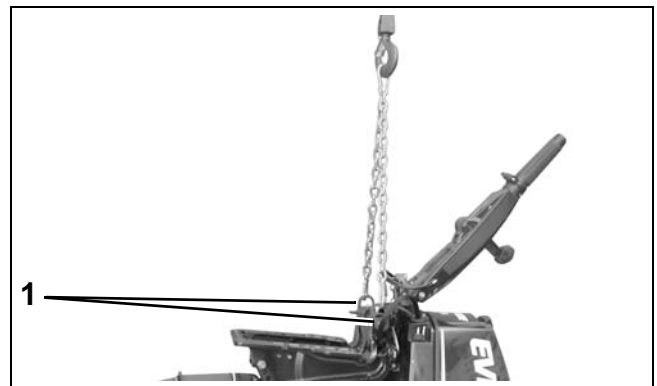

1. Lifting tool, P/N 354717

007123

Remove upper motor cover.

Place clean pad or cardboard on the floor.

## ROUTINE SERVICE

### LIFTING THE OUTBOARD

Lower outboard onto the pad. Use hoist to carefully roll the outboard onto its port side.

#### **⚠ CAUTION**

To avoid damage to the outboard, **DO NOT** allow the outboard to fall unrestrained.

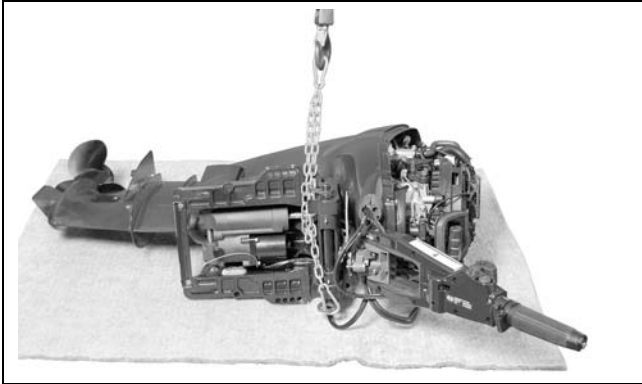

007211

Remove chain from lifting tool.

Remove lifting tool from outboard.

Attach chain to lift eye on back of engine block.

#### **⚠ WARNING**

If the chain snap hooks are too large, the cast in lift eye could break causing the outboard to drop suddenly causing personal injury and damaging the outboard.

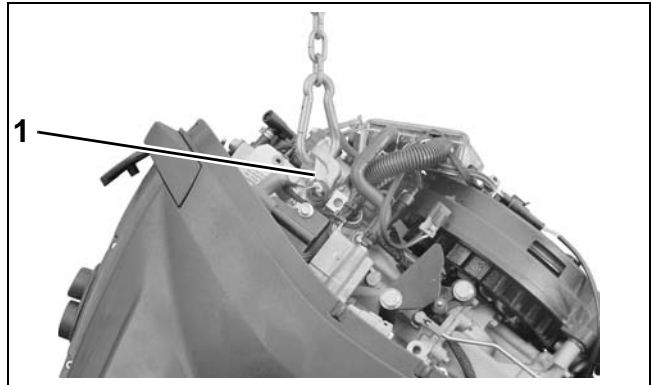

1. Lift eye

007212

Carefully lift engine with hoist.

**NOTICE** To avoid damage to the outboard, lift the outboard in one smooth motion. **DO NOT** allow the outboard to bounce.

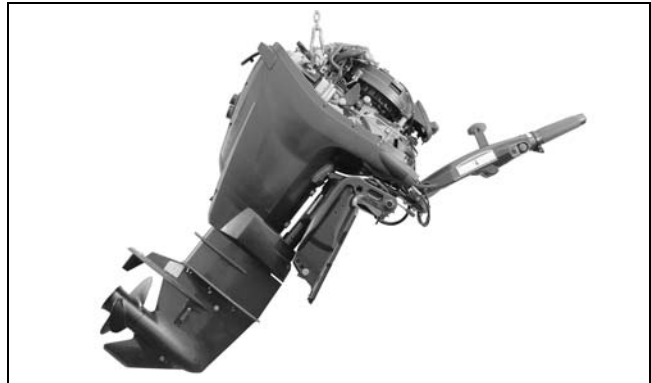

007213

# OUTBOARD RIGGING CONNECTIONS

**IMPORTANT:** For complete outboard rigging and remote control installation information, refer to the **Predelivery and Installation Guide** included with the service manual set.

## Common Practices – All Models

### Control Cable Identification

**IMPORTANT:** Control cable function must be identified before rigging outboard.

Identify each control cable:

- Put the control handle into NEUTRAL position. The throttle cable casing guide will retract completely and the shift cable casing guide will go to the midpoint of its travel.

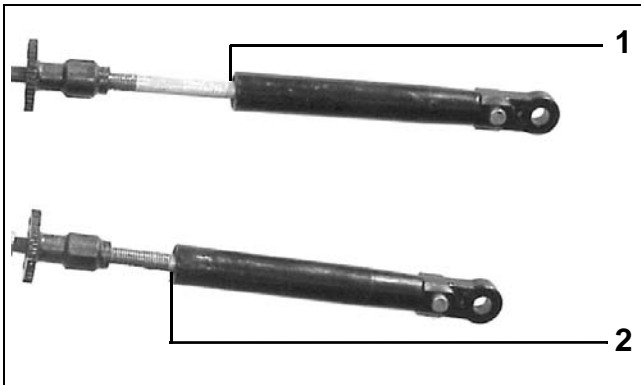

1. Shift cable casing guide extended to midpoint DP0811  
2. Throttle cable casing guide retracted

Extend the control cables and lubricate them with *Triple-Guard* grease.



30501

### Cable Retainer Clip Installation

When installing retainer clips on control arm linkage pins, clips should be locked and **must not** be bent or deformed.

For proper installation, review the following steps:

- Place washer on pin.
- Position retainer clip with straight section on the bottom and angled section on the top.
- Use long nose pliers to insert straight section of clip into linkage pin hole.

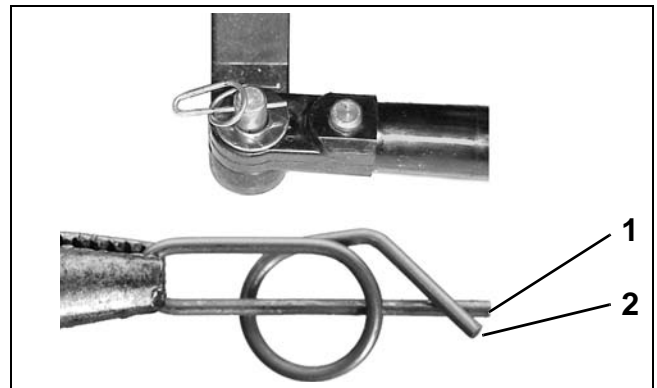

1. Straight section  
2. Angled section

DP0818  
DSC\_4670

- Push the clip towards the hole while lifting on the curved end with the pliers.
- Be sure retainer clip fully engages the pin.
- Lock the retainer by moving the angled section **behind** the straight section.



**Locked Retainer Clip**

1. Angled section behind straight section

DP0817a

## ROUTINE SERVICE

### OUTBOARD RIGGING CONNECTIONS

## Cable, Hose, and Wire Routing

### ⚠ CAUTION

To prevent accidental starting while servicing, disconnect the battery cables at the battery. Twist and remove all spark plug leads.

Refer to **Control Cable Identification** on p. 17.

Remove cable entry grommet cover and grommet.

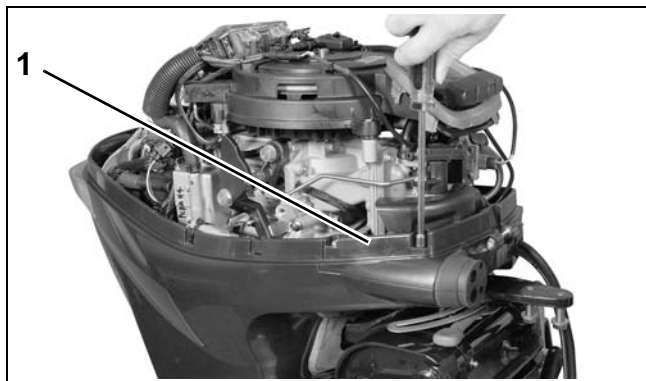

1. Cable entry grommet cover

007120

Remove rubber membrane from grommet holes as needed.

Install cables and wiring harness(es) through grommet as shown:

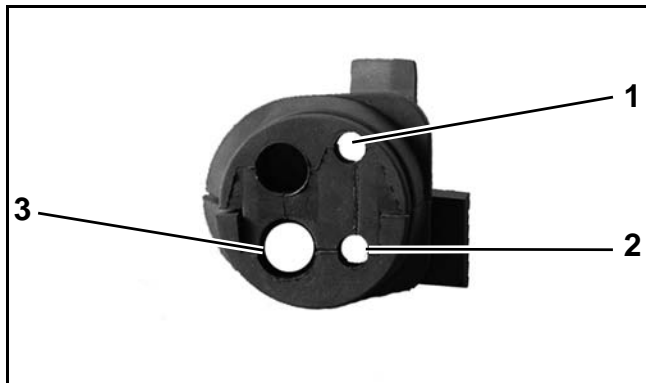

1. Throttle cable  
2. Shift cable  
3. Tiller wiring harness

007129

When grommet is in place and all cables have been installed, tighten a tie strap around the outside of the grommet to form a watertight seal around the cables.

Place blank sealing decal on lip of lower motor cover at each harness connector tie strap to prevent water intrusion.

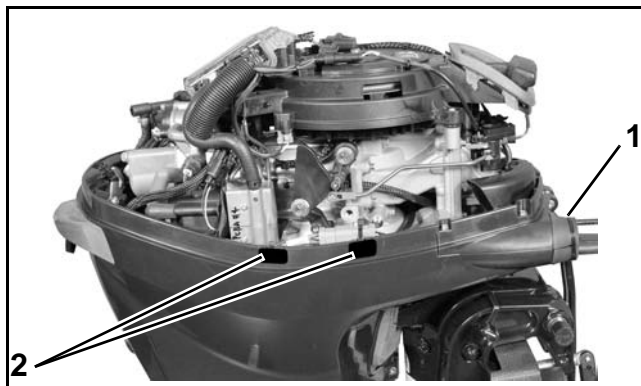

1. Tie strap  
1. Blank sealing decal

007127

**NOTICE** After installation, make sure there is enough clearance for all cables to avoid binding or chafing through all engine steering and tilting angles.

## Control Cable Installation

Refer to **Control Cable Identification** on p. 17.

Make sure the remote control is in NEUTRAL, and throttle is in the IDLE position.

Removal of lower motor covers is NOT required. Some images show lower covers removed for clear illustration.

Place the shift cable on the shift lever pin.

Hold the shift linkage in NEUTRAL.

Push and pull on the shift cable and observe the cable slack. Hold the casing guide in the center of the slack.

## ROUTINE SERVICE OUTBOARD RIGGING CONNECTIONS

2

Adjust the shift cable trunnion to align with the center of the trunnion block.

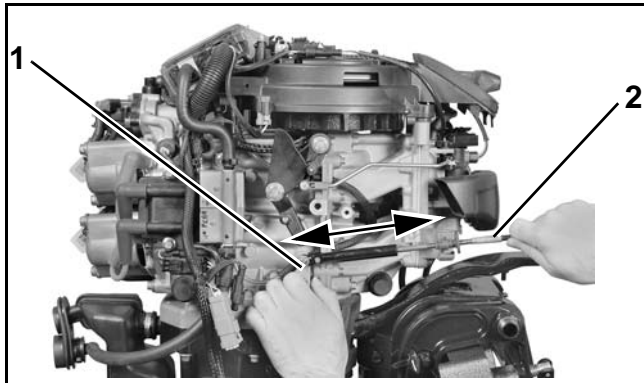

1. Shift linkage 007215  
2. Shift cable

adjust the trunnion nut so the casing fits onto the throttle lever pin.

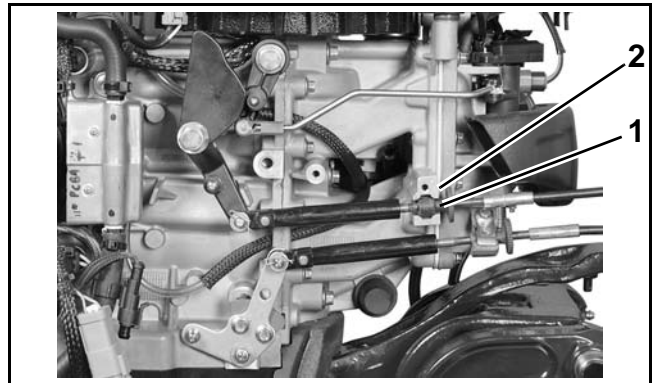

1. Throttle cable trunnion 007217  
2. Trunnion block

Install cable retainer and screw. Tighten screw to a torque of 60 to 84 in. lbs. (7 to 9.5 N·m).

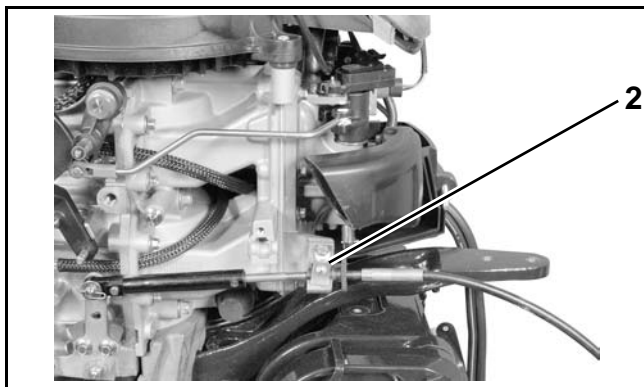

1. Cable retainer 007121

With remote control lever in NEUTRAL, pull firmly on throttle cable casing to remove slack.

With engine throttle lever against stop, place the cable trunnion into the upper anchor pocket and

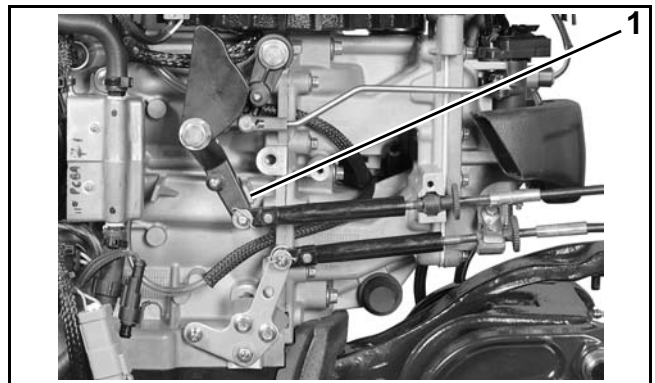

1. Idle stop 007216

**IMPORTANT:** Move control handle to FORWARD and pull back slowly to NEUTRAL. Make sure the engine throttle lever is against the stop. If not, remove slack by adjusting cable trunnion.

Install cable retainer and screw. Tighten screw to a torque of 60 to 84 in. lbs. (7 to 9.5 N·m).

Install washers and retainer clips on shift lever and throttle pins. Refer to **Cable Retainer Clip Installation** on p. 17.

**ROUTINE SERVICE**  
**OUTBOARD RIGGING CONNECTIONS**

**SystemCheck Harness Connections**

Before installing electrical connectors, check that the seal is in place. Clean off any dirt from connectors. Apply a light coat of *Electrical Grease* to the seal only. **DO NOT** fill connectors with *Electrical Grease*.

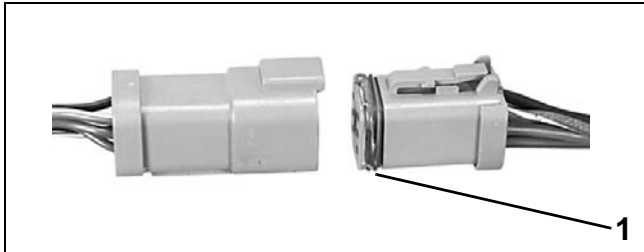

1. Seal 42079A

Route electrical harness along the edge of the lower engine cover.

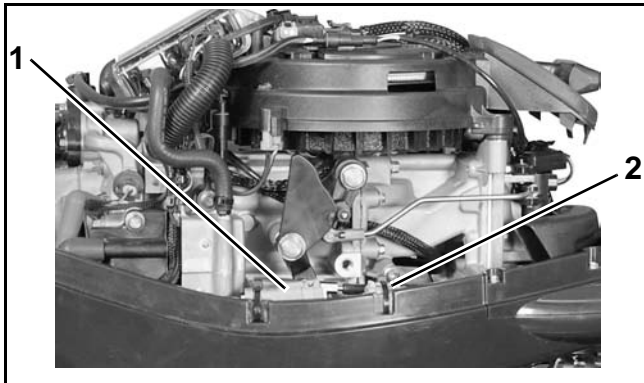

1. Key switch connector 007263  
 2. Tachometer connector

Secure connectors to lower motor cover with two tie straps as shown.

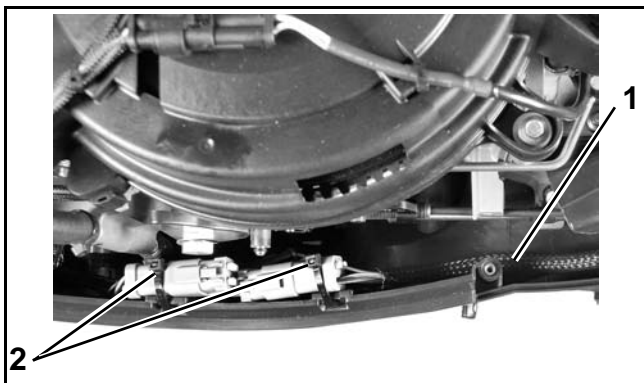

1. Wire routing 007125  
 2. Secure with two tie straps

Route trim and tilt connector under air silencer. Use tie strap to secure connector as shown.



1. Trim and tilt connector 007264

Install battery cables and secure with tie strap.

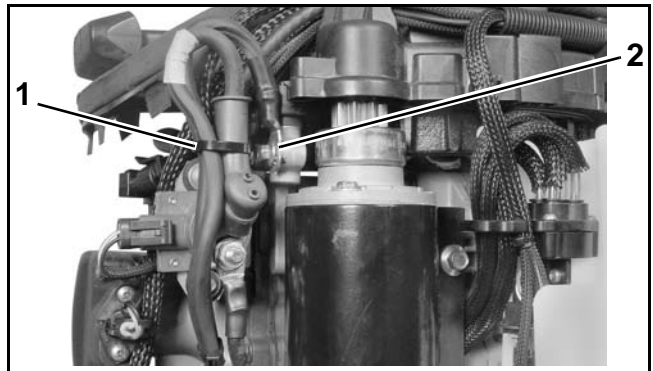

1. Tie strap 007240  
 2. Battery cable ground

Route battery cable through grommet of port lower motor cover.

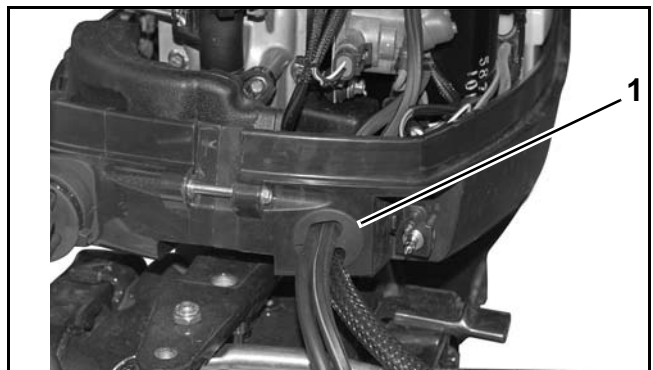

1. Battery cable grommet 008009

**NOTICE** BE SURE all harnesses and wires are not pinched, cannot contact flywheel, and do not interfere with moving throttle or shift linkages.

## BATTERY AND BATTERY CONNECTIONS

### WARNING

Keep the battery connections clean, tight, and insulated to prevent their shorting or arcing and causing an explosion. If the battery mounting system does not cover the connections, install protective covers. Check often to see that connections stay clean and tight.

Check battery connections frequently. Periodically remove battery to clean and service connections.

- Confirm that battery meets the minimum engine requirements.
- Connections must be clean and tight.
- Observe all wiring connections prior to disassembly.

Disconnect battery negative (–) cable **first** and the battery positive (+) cable last.

Clean all terminals, battery posts, and connectors with a solution of baking soda and water. Use a wire brush or battery terminal tool to remove corrosion buildup. Rinse and clean all surfaces.

**IMPORTANT:** Connect the battery positive (+) cable to the battery positive (+) post **FIRST**. Connect the battery negative (–) cable to the battery negative (–) post **LAST**.

Install a starwasher on the threaded battery post. Stack cables from the outboard, then cables from accessories. Finish this connection with a hex nut.

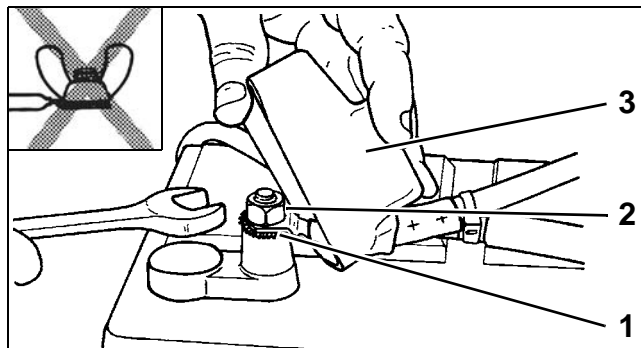

Marine Style Battery Post

DR5103

1. Starwasher
2. Hex nut
3. Terminal Insulator

**NOTICE** Do not use wing nuts to fasten ANY battery cables. Wing nuts can loosen and cause electrical system damage not covered under warranty.

Tighten all connections securely. Apply *Triple-Guard* grease to prevent corrosion.

### WARNING

Battery electrolyte is acidic—handle with care. If electrolyte contacts any part of the body, immediately flush with water and seek medical attention.

# OETIKER CLAMP SERVICING

## Clamp Identification

Use *Oetiker* clamps for making hose connections. These clamps provide corrosion resistance, minimize the potential for abrasion of rigging components, and provide solid, permanent connections.

The selection and installation of an *Oetiker* clamp is essential in the proper sealing of hose connections. The clamp identification numbers appear on the side of the clamp, near the top of the ear. Refer to **Clamp Selection** chart for dimensions.

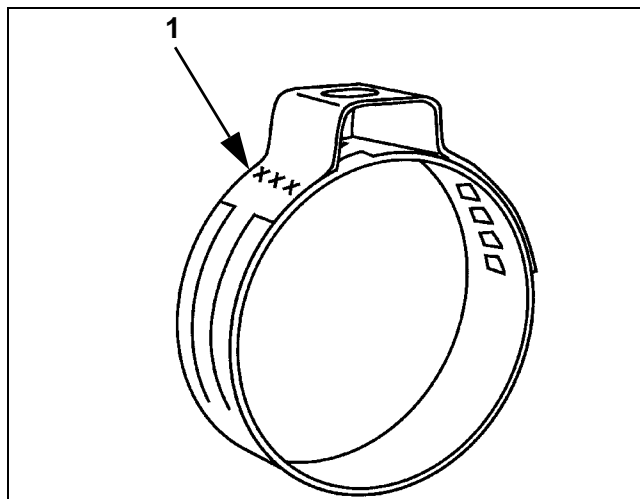

1. Clamp identification numbers

000093

**⚠ WARNING**  
**DO NOT re-use Oetiker clamps. Fuel leakage could contribute to a fire or explosion.**

## Clamp Selection

To select the correct size *Oetiker* clamp, measure the outside diameter of the hose when installed on the fitting.

Chose a clamp so that the outside diameter of the hose is approximately in the middle of the clamping range of the clamp.

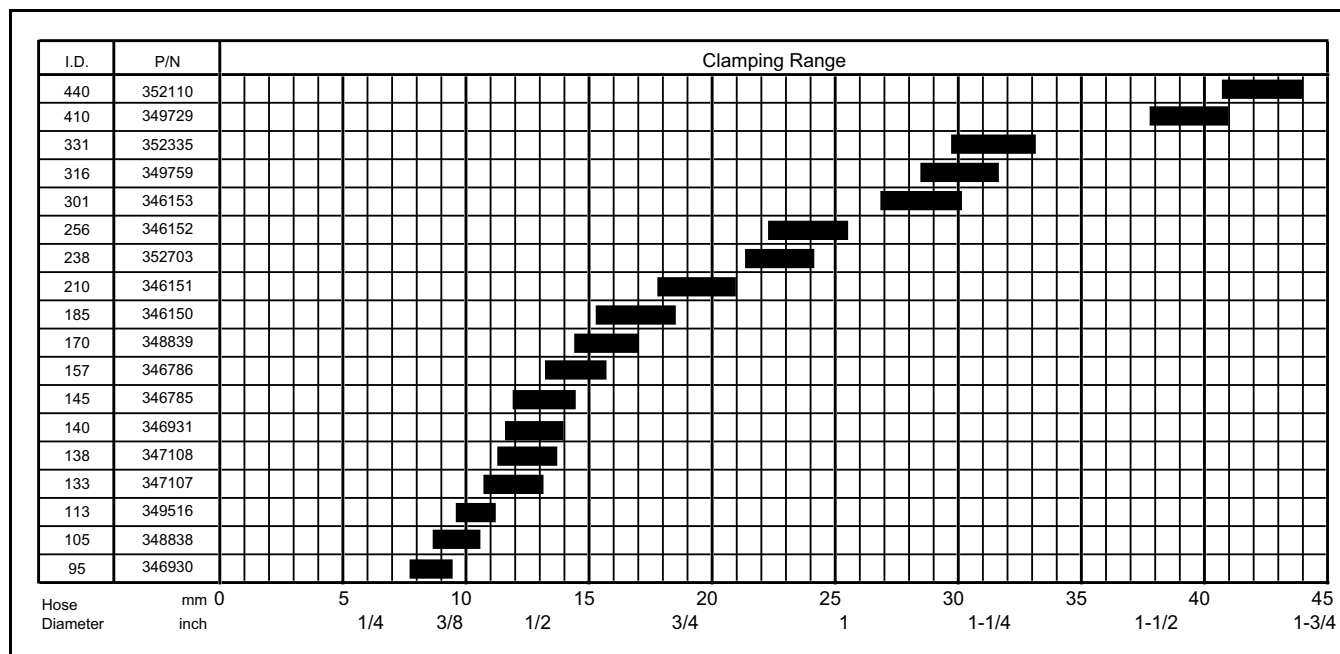

008458



## Clamp Installation

A constant stress should be applied to close the ear clamps. This method ensures a positive stress on the hose and does not result in excessive compression or expansion of the band material.

**IMPORTANT:** Use only *Oetiker* recommended tools to close *Oetiker* stepless clamps.

*Oetiker* pincers are available in the *Evinrude/Johnson Genuine Parts and Accessories Catalog*.



DP0886

- Position correct size clamp over hose.
- Install hose on fitting.
- Close clamp ear fully with *Oetiker* pincers (pliers).

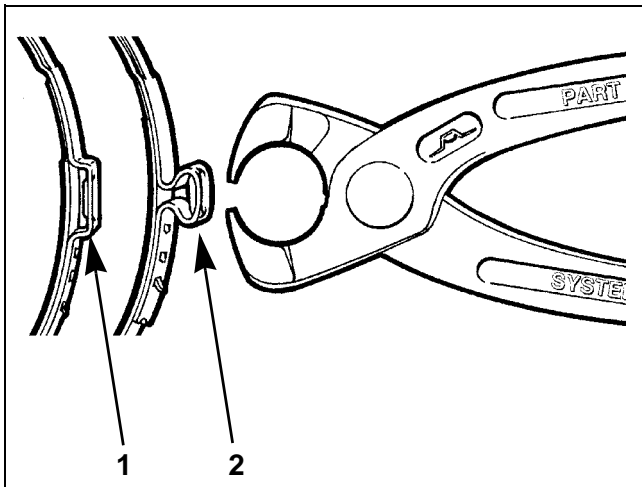

1. Open clamp
2. Closed clamp

000092

## Clamp Removal

**Method 1:** Position *Oetiker* pincers across clamp ear and cut clamp.

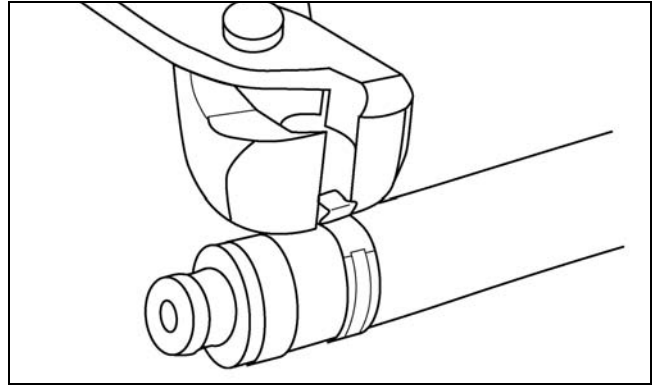

000108

**Method 2:** Lift end of stepless clamp with screwdriver.

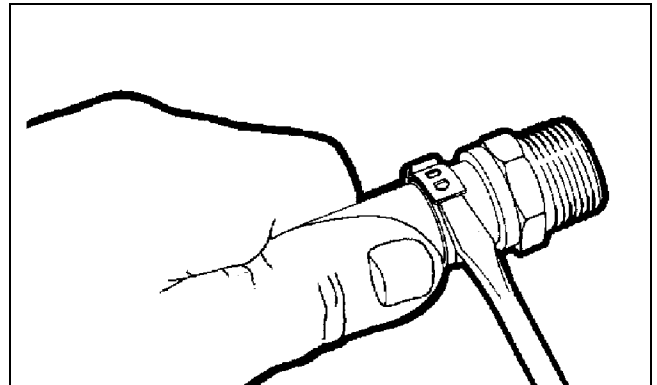

000090

**Method 3:** Use *Oetiker* pincers (pliers) to grip clamp. Pull clamp off of connection and discard.

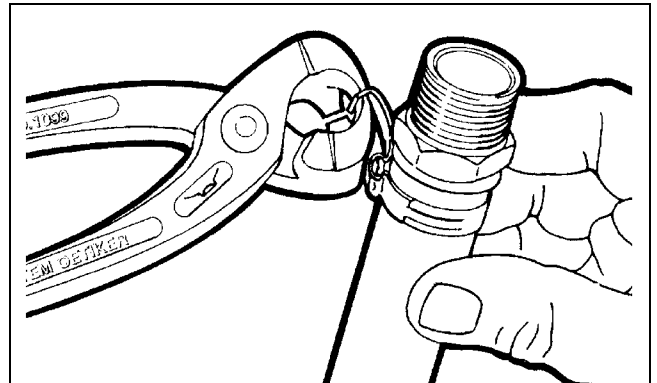

000091

# ADJUSTMENTS

## Steering Friction Adjustment

**⚠ WARNING**

Steering friction device is not intended to hold boat on a set course.

**DO NOT** overtighten steering friction for “hands-off” steering. Reduced steering control of the boat could result in loss of control by the operator, creating a risk of personal injury or property damage.

### Initial Adjustment

Perform this adjustment after installing steering friction device, or if steering friction device no longer provides enough steering friction.

Position steering friction lever as shown. Tighten locking nut so that a slight drag is felt when steering.

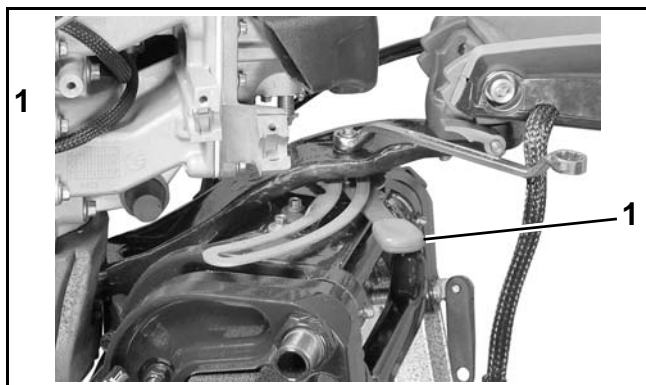

3. Steering friction lever 007463

### Operational Adjustment

A slight drag should be felt when turning the outboard with the steering handle. If adjustment is necessary, move the throttle friction lever:

- To PORT to increase friction; or

- To STARBOARD decrease friction.

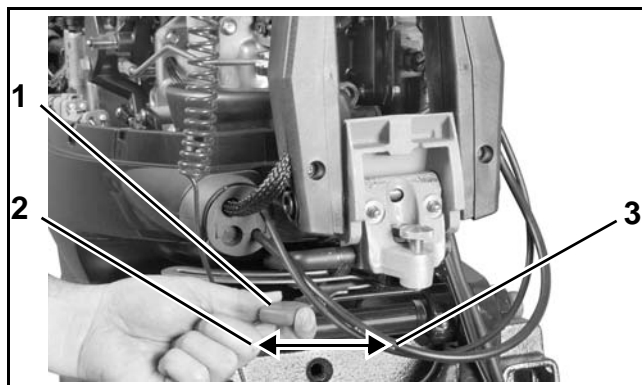

1. Steering friction lever  
2. Decrease friction  
3. Increase friction

007454

## Throttle Friction Adjustment

Tiller models are equipped with a throttle friction adjustment knob located on the steering handle. Tighten the knob to reduce the effort required to hold a throttle setting.

Turn the knob:

- clockwise to increase friction
- counterclockwise to decrease friction

**⚠ WARNING**

**Tighten knob only enough to hold throttle at a constant engine speed. Overtightening will prevent quick throttle change in case of emergency.**

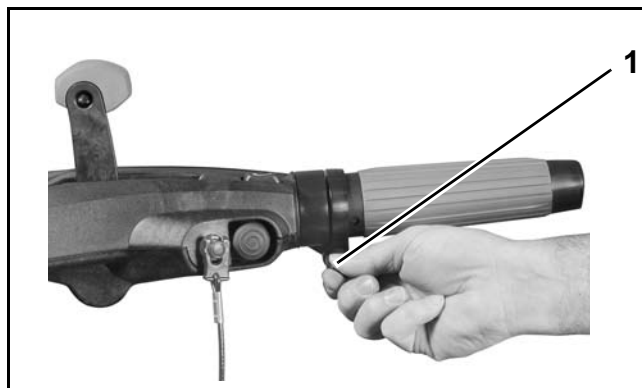

1. Throttle friction knob

007452

## Tiller Height Adjustment

The angle of the tiller handle can be raised or lowered by adjusting a thumbscrew under the handle.

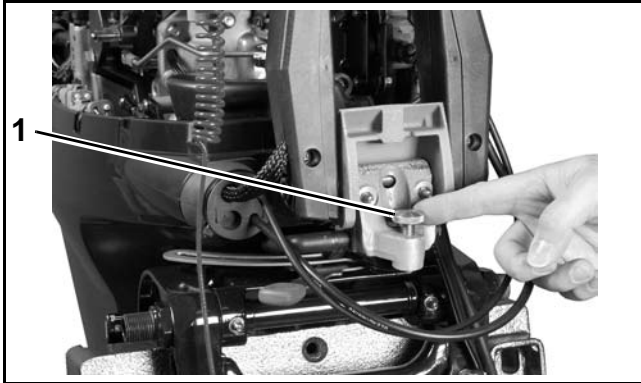

1. Height adjustment screw

007453

## Tiller Handle Friction

The tiller handle screw may be tightened to adjust the amount of friction when tilting the tiller handle.

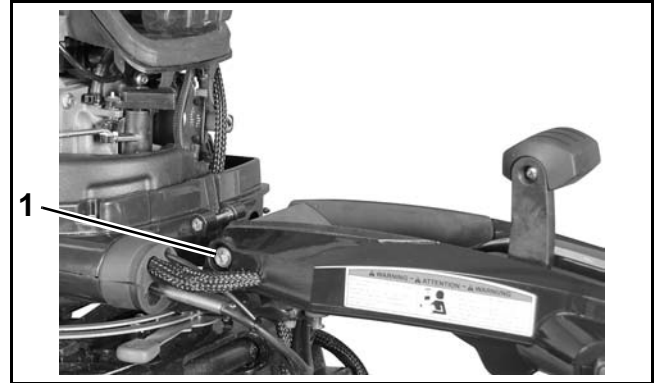

1. Screw

007484

## Tiller Handle Ratchet

Tiller models feature a ratchet which holds the tiller arm at approximately 30° or 90° positions. To release the tiller arm, press up on the release lever.

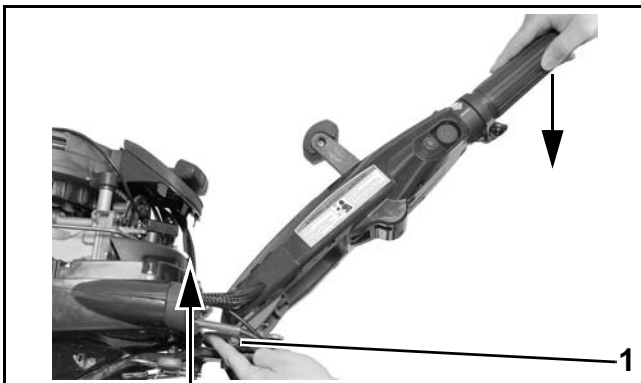

1. Release lever

007483

## Neutral Switch Adjustment

Adjust neutral switch as follows:

Make sure neutral switch is centered on shift lever detent.

- Loosen two neutral switch bracket screws.
- Center the neutral switch on lobe of the shift lever detent.
- Hold neutral switch bracket in position and tighten screws to a torque of 35 to 60 in. lbs. (4 to 6.8 N·m).

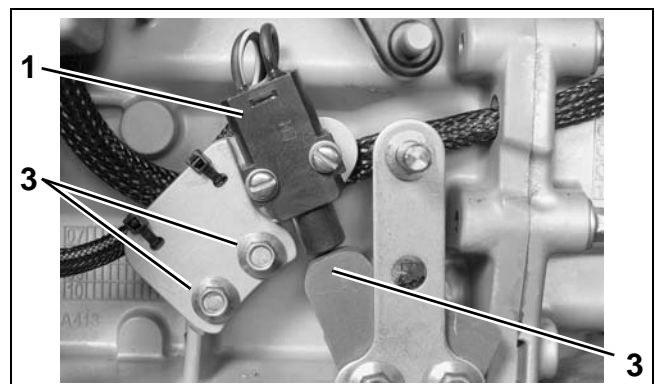

1. Neutral switch  
2. Lobe of shift lever detent  
3. Neutral switch bracket screws

008462

## Check Neutral Switch Operation

Use *Evinrude Diagnostics* software "Monitor" screen to confirm neutral switch operation.

## ROUTINE SERVICE ADJUSTMENTS

Shift the engine from NEUTRAL to FORWARD gear. The Neutral/In Gear indicator must indicate "In Gear."

Shift the engine from FORWARD gear to NEUTRAL. The Neutral/In Gear indicator must indicate "Neutral."

Shift the engine from NEUTRAL to REVERSE gear. The Neutral/In Gear indicator must indicate "In Gear."

Shift the engine from REVERSE gear to NEUTRAL. The Neutral/In Gear indicator must indicate "Neutral."

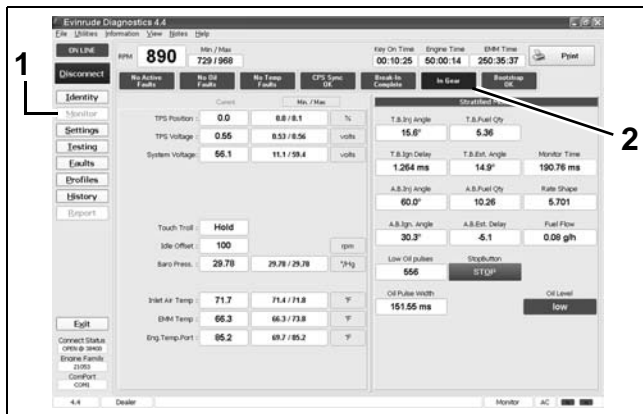

1. Monitor screen
2. Neutral/In Gear indicator

008137

Readjust the neutral switch and confirm neutral switch operation if the Neutral/In Gear indicator does not match engine shift position.

### Trim Sending Unit Adjustment

The sending unit eccentric cam must be adjusted so that the gauge needle is aligned with the lowest

gauge mark with the outboard trimmed all the way DOWN.

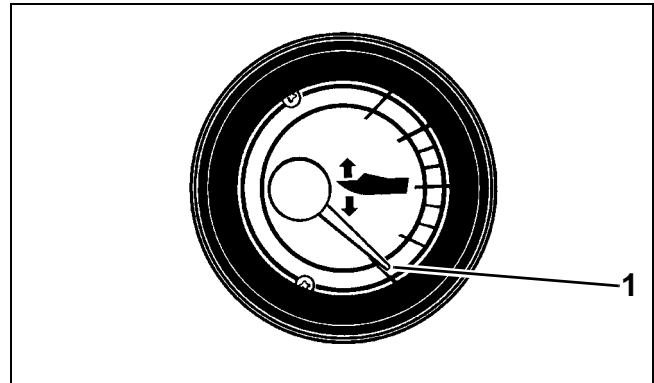

1. Lowest gauge mark

DR2827

Check if the gauge needle is above or below the lowest gauge mark. Tilt engine UP and engage trailering lock.

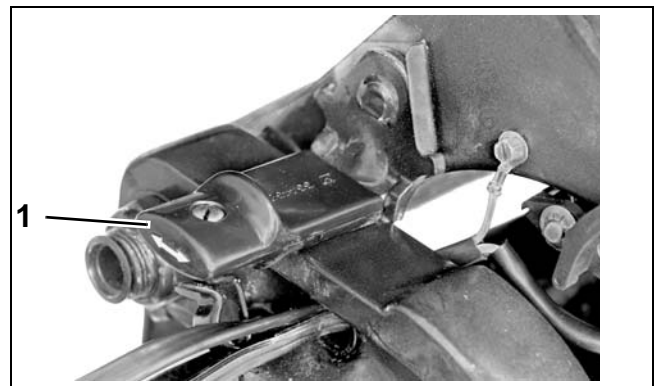

1. Trailering lock

18954

### **⚠ WARNING**

**To avoid personal injury, do not adjust the sending unit eccentric cam while the engine is being tilted.**

When the outboard is trimmed all the way DOWN, the sending unit lever touches the eccentric cam just forward of the top of the cam at the contact point.

Loosen cam screw and rotate eccentric cam to adjust full down gauge position:

- If the needle was above the lowest mark, move the thick part of the cam TOWARD the contact point. Tighten the screw, and recheck the gauge reading.

- If the needle was below the lowest mark, move the thick part of the cam AWAY from the contact point. Tighten the screw, and recheck the gauge reading.

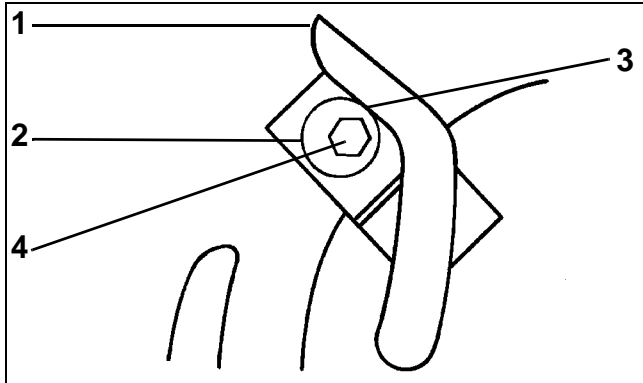

1. Lever
2. Eccentric cam
3. Contact point
4. Cam screw

DR5090

Tighten eccentric cam retaining screw and check needle position at full trim DOWN.

## Trim Tab Adjustment

### **⚠ WARNING**

**Improper trim tab adjustment can cause difficult steering and loss of control.**

A propeller will generate steering torque when the propeller shaft is not running parallel to the water's surface. The trim tab is adjustable to compensate for this steering torque.

**IMPORTANT:** A single trim tab adjustment will relieve steering effort under only one set of speed, outboard angle and load conditions. No single adjustment can relieve steering effort under all conditions.

If the boat pulls to the left or right when its load is evenly distributed, adjust the trim tab as follows:

- With the remote control in NEUTRAL and the engine OFF, loosen the trim tab screw.
- If the boat pulled to the right, move rear of the trim tab slightly to the right.
- If the boat pulled to the left, move rear of the trim tab slightly to the left.

Tighten the trim tab screw as follows:

- **15 – 30 HP:** 60 to 80 in. lbs. (7 to 9 N·m).

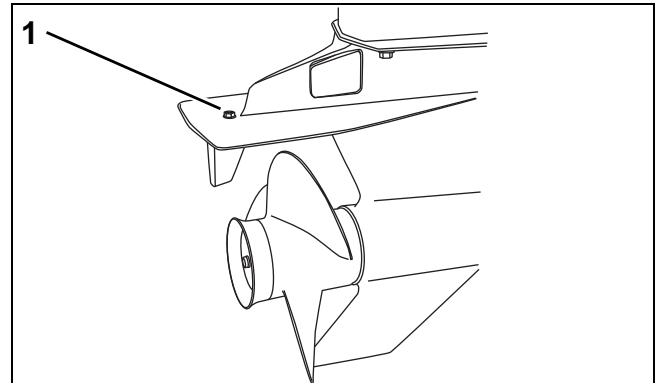

1. Trim tab screw

007044

Test the boat and, if needed, repeat the procedure until steering effort is as equal as possible.

## Outboards with High Transom Heights

The trim tab may be above the surface of the water when the outboard is trimmed out. Steering effort might increase. Lower the trim setting to submerge the trim tab and to reduce steering effort.

## OPERATIONAL CHECKS

### **DANGER**

**DO NOT** run the engine indoors or without adequate ventilation or permit exhaust fumes to accumulate in confined areas. Engine exhaust contains carbon monoxide which, if inhaled, can cause serious brain damage or death.

### **WARNING**

Contact with a rotating propeller is likely to result in serious injury or death. Assure the engine and prop area is clear of people and objects before starting engine or operating boat. Do not allow anyone near a propeller, even when the engine is off. Blades can be sharp and the propeller can continue to turn even after the engine is off.

### **CAUTION**

**DO NOT** run outboard without a water supply to the outboard's cooling system. Cooling system and/or powerhead damage could occur.

## Engine Monitoring System

Attach emergency stop lanyard.

Turn key switch to ON. Warning horn should sound for 1/2 second.

All *SystemCheck* warning lights should turn on at the same time, then turn off one at a time.

## Fuel System

Perform running checks of the fuel system by following these steps:

- Squeeze fuel primer bulb until hard or activate electric primer. Observe all fuel hoses and connections. Repair any leaks.
- Start outboard. Inspect all hoses and connections. Repair any leaks or misrouted hoses immediately.

## Emergency Stop / Key Switch

Check emergency stop function. With outboard running at IDLE, pull safety lanyard from emergency stop switch. Outboard must stop immediately.

## Remote Control Operation

Make sure that control can be easily moved into all gear and throttle settings. Do not shift remote control when outboard is not running.

## Start-In-Gear Prevention

### **WARNING**

**Make certain that the starter will not operate when the outboard is in gear. The start-in-gear prevention feature is required by the United States Coast Guard to help prevent personal injuries.**

Start outboard and shift to FORWARD.

Turn outboard OFF while control is in FORWARD.

Try to restart the outboard. Outboard should not start.

Shift back to NEUTRAL and restart outboard.

Shift to REVERSE. Turn outboard OFF while control is in REVERSE.

Try to restart the outboard. Outboard should not start.

## Tachometer Pulse Setting (*SystemCheck*)

Confirm accuracy of tachometer reading.

- Adjust dial on back of tachometer to required setting (the outboard should not be running).

Outboard Model	Tachometer Setting
15–30 HP	6 Pulse or 12 Pole

## Water Pump Overboard Indicator

A steady stream of water should flow from the overboard indicator.

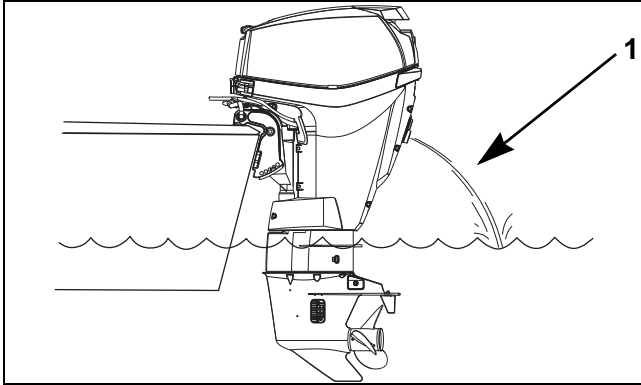

1. Water pump overboard indicator

007031

## Operating Temperature

An outboard run at idle speed should achieve a temperature based on the engine's thermostatic control. In general, the powerhead temperature should reach at least 104°F (40°C) after five minutes of idling. Check that the powerhead reaches idle temperature. Refer to **SERVICE SPECIFICATIONS** on p. 10.

## Idle Speed

Make sure the outboard idles within the specified idle RPM range. If the outboard is run on a flushing device, the idle speed and quality may not be representative of actual in water use.

## COOLING SYSTEM

Check the condition of cooling system components regularly:

- water intake screens
- water pump
- all internal water passages
- thermostats
- all external water hoses and fittings
- vapor separator cooling passages and fittings
- *EMM* cooling passages and fittings
- overboard water pressure indicator.

## Water Intake Screens

Inspect condition of water intake screens. Clean or replace as needed.

Confirm function of overboard water pressure indicator.

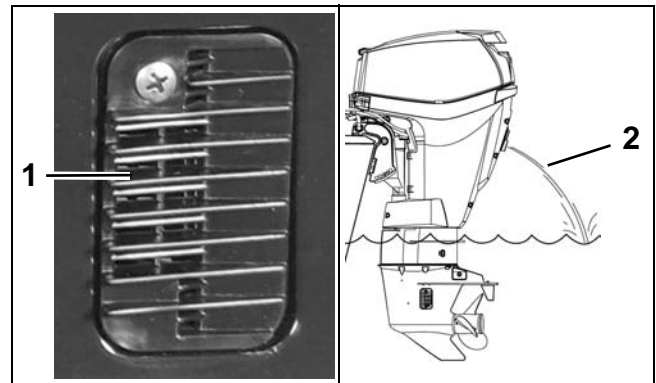

1. Water intake screen  
2. Overboard indicator

007271  
007016s

---

## ROUTINE SERVICE

### COOLING SYSTEM

---

## Engine Flushing

Flush the outboard with fresh water following each use in brackish, salt, or polluted water to minimize the accumulation of scale and silt deposits in cooling system passages.

The outboard can be flushed on the trailer or at dockside; running or not running.

**IMPORTANT:** The outboard must be located in a well ventilated area with appropriate ground drainage during the flushing procedures.

Keep water inlet pressure between 20 to 40 psi (140 to 275 kPa).

### Flushing — Outboard Running

**⚠ WARNING**

**To prevent injury from contact with rotating propeller, remove the propeller before flushing.**

Place outboard in VERTICAL (DOWN) position in a well ventilated area.

Thread garden hose into flushing port.

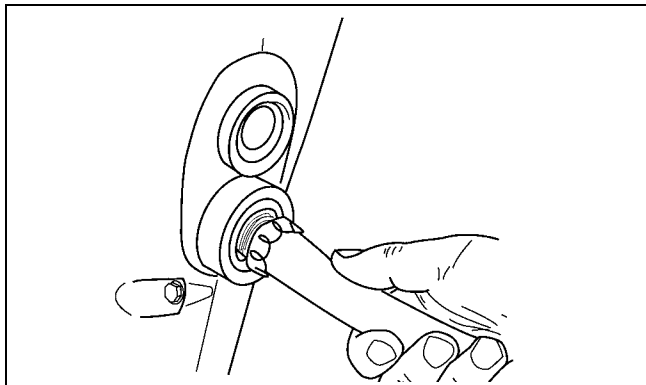

002024

Turn water supply on.

Run outboard at IDLE only until full operating temperature is reached.

Leave the outboard in VERTICAL (DOWN) position long enough for the powerhead to drain completely.

Reinstall propeller.

### Flushing — Outboard Not Running

Outboard can be in VERTICAL (DOWN) or TILTED (UP) position.

Thread garden hose into flushing port.

Turn water supply ON.

Flush outboard for at least five minutes.

Turn off water supply and remove garden hose.

Position outboard in VERTICAL position (DOWN) long enough to allow the powerhead to drain completely.



## Running the Outboard Using a Hose and Flushing Adapter

### WARNING

To prevent injury from contact with rotating propeller, remove the propeller before running engine with a flushing adapter.

A flushing adapter may be used to provide cooling water when running the outboard to:

- Flush the engine
- Run for an extended period of time, such as when performing diagnostic work
- Run the engine on a dynamometer
- Prepare the outboard for storage.

**IMPORTANT:** The outboard must be located in a well ventilated area with appropriate ground drainage.

Keep water inlet pressure between 20 to 40 psi (140 to 275 kPa).

Be sure water supply is sufficient to run the engine above idle speed.

### Water Supply Requirements

Model	Water Flow @ WOT
15–30 HP	1.5 to 3 GPM <sup>1</sup> (5 to 11 LPM <sup>2</sup> )

1. GPM: Gallons per minute

2. LPM: Liters per minute

Install flushing adapter onto gearcase water inlet screens.

**NOTICE** Temporarily cover the two small holes on each side of the gearcase with waterproof tape to make sure enough water travels

to the powerhead. Water can drain from auxiliary inlets, resulting in engine overheat.

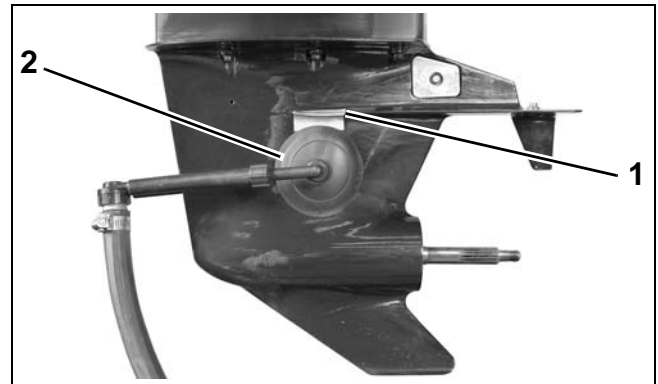

1. Water-proof tape  
2. Flushing adapter

008355

A steady stream of water should flow from the overboard indicator while the engine is running.

Monitor engine water pressure gauge when:

- Engine speed is above 3000 RPM
- Running engine on a dynamometer.

**NOTICE** Engine will overheat if normal water pressure is not maintained. Temporarily install an engine water pressure gauge if not equipped with one.

Be sure to remove waterproof tape from auxiliary water inlets.

**NOTICE** Engine will overheat if auxiliary water inlets are restricted when outboard is back in service.

# LUBRICATION

## Steering System

**⚠ WARNING**

Failure to regrease as recommended could result in steering system corrosion. Corrosion can affect steering effort, making operator control difficult.

Grease the stainless steel output end of the steering cable with *Triple-Guard* grease.

Use an appropriate cleaning solvent to remove corrosion and dirt from output end of cable before coating it with grease. Make sure wiper nut is installed and not damaged.

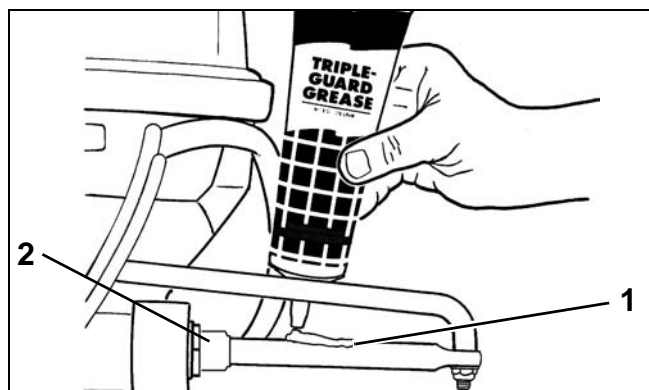

- 1. Steering cable
- 2. Wiper nut

DR29546

## Tiller Handle

Lubricate the tiller handle grease fittings with *Triple-Guard* grease.

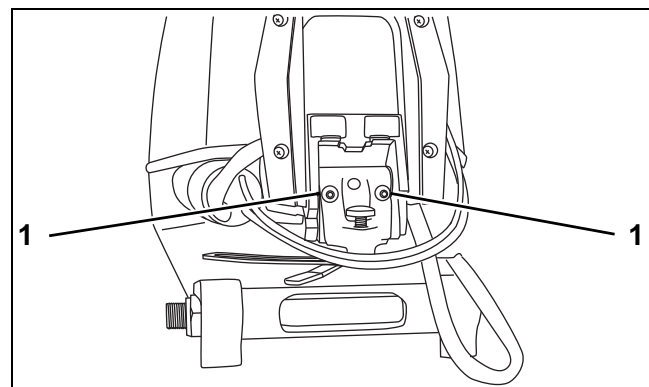

- 1. Tiller handle fittings

007020A

## Swivel Bracket and Trailing Bracket

Lubricate the swivel bracket with *Triple-Guard* grease.

Apply grease until the grease begins to flow from the upper or lower swivel bracket areas.

Coat the pivot points of the trailing bracket with *Triple-Guard* grease.

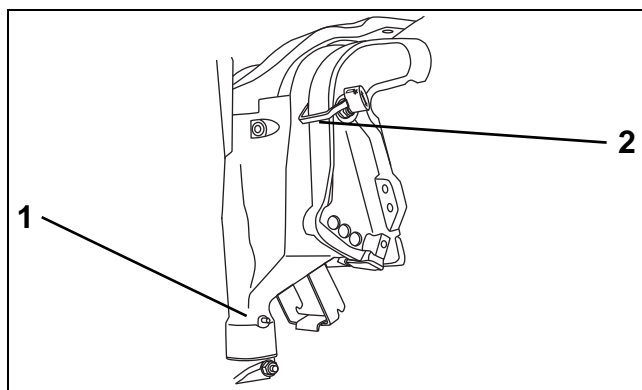

- 1. Grease fitting
- 2. Tilt support

007032

## Tilt Tube

Lubricate the tilt tube grease fittings with *Triple-Guard* grease.

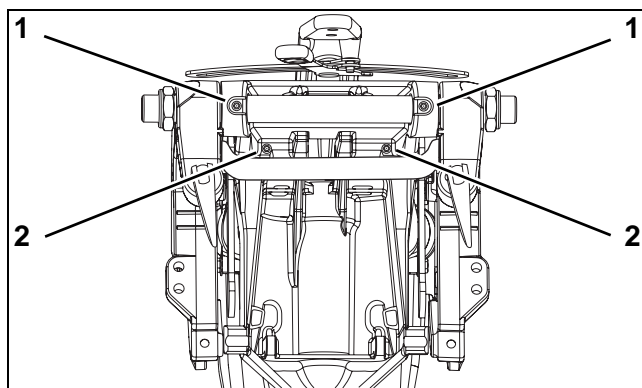

- 1. Tilt tube fittings
- 2. Swivel bracket fittings

007033

## Throttle and Shift Linkage

Disconnect the battery cables at the battery.

Remove clips and washers from throttle and shift lever pins. Carefully, remove casing guides from pins.

**IMPORTANT:** DO NOT disturb cable trunnion adjustments.

Shift remote control into FULL THROTTLE/REVERSE position to fully extend the plastic casing guides.

Apply *Triple-Guard* grease to:

- Cable attachment pins of both the throttle and shift levers
- Inner casings of both the throttle and shift cables.

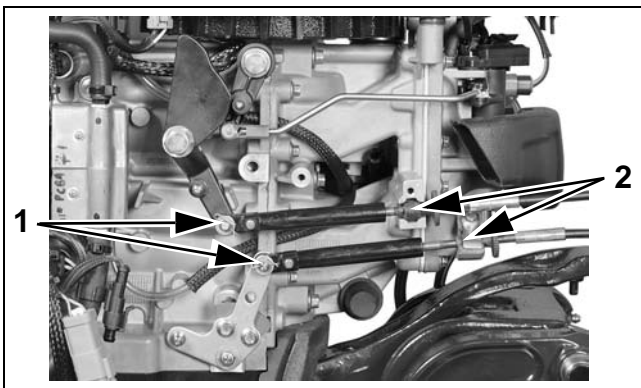

1. Attachment pins, throttle and shift cables 007217  
2. Inner casings, throttle and shift cables

Shift the remote control to the NEUTRAL/IDLE position.

Install control cables.

Check proper throttle and shift function.

## Propeller Shaft

Debris from the water can become lodged around propeller shaft. Frequent inspection can minimize potential gearcase damage.

### WARNING

**When servicing the propeller, always shift the outboard to NEUTRAL, turn the key switch OFF, and disconnect the battery cables at the battery.**

Remove propeller. Refer to **Propeller Hardware Installation** on p. 246.

Inspect bushing and blade surfaces. Replace damaged or worn propellers.

Clean propeller shaft. Inspect propeller shaft seals. Replace damaged or worn seals.

Apply *Triple-Guard* grease to entire length of propeller shaft prior to installing propeller.

Reinstall propeller hardware and propeller.

## ROUTINE SERVICE LUBRICATION

### Gearcase Lubricant

#### Draining

#### WARNING

Gearcase lubricant may be under pressure and/or hot. If plug is removed from a recently operated outboard, take precautions to avoid injury.

**IMPORTANT:** Always check the fill level of the gearcase lubricant at the upper plug before removing the lower, drain/fill plug. A tie strap can be used to check lubricant level.

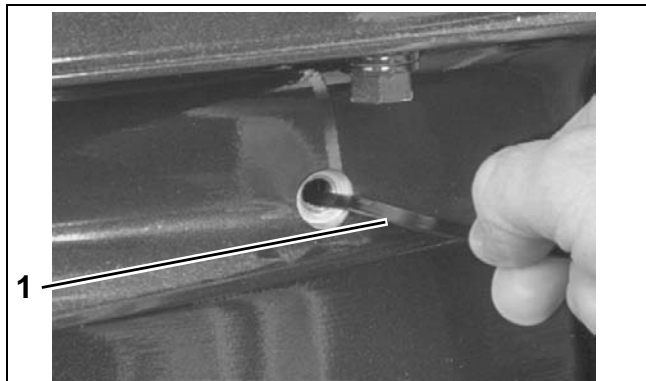

1. Tie strap

000072

If lubricant level is low, refer to **GEARCASE LEAK TEST** on p. 247.

Remove the lubricant level plug, then the lubricant drain/fill plug, and drain the lube from the gearcase into a container.

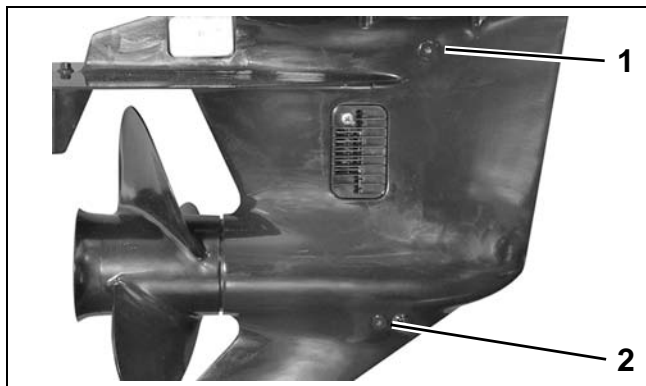

1. Lubricant level plug

2. Lubricant drain/fill plug

007272

#### Inspection

Inspect the lube and the magnets on the plugs for metal chips. The presence of metal **fuzz** can indicate normal wear of the gears, bearings, or shafts within the gearcase. Metal **chips** can indicate extensive internal damage.

Inspect the lubricant for water contamination. Water can make the lubricant milky in appearance. However, normal aeration can also cause the same appearance.

To check for water contamination, put lubricant into a glass container. Allow the oil to settle for a minimum of one hour to determine if there is an abnormal amount of water in the oil.

If water is present, refer to **GEARCASE LEAK TEST** on p. 247.

Overheated lubricant will have a black color and burned odor.

Internal gearcase inspection is recommended when lubricant is contaminated or shows signs of failure.

#### Filling

Refer to the **INSPECTION AND MAINTENANCE SCHEDULE** on p. 14 for service frequency and recommended lubricants.

Secure the gearcase in a vertical position.

Remove the lubricant level plug and the lubricant drain/fill plug.

Use Gearcase Filler, P/N 501882, to slowly fill the gearcase with *HPF PRO* lubricant through the drain/fill hole until it appears at the oil level hole.

**IMPORTANT:** Filling the gearcase too quickly can cause air pockets and the gearcase may not fill completely.

Clean plug seal area and install the lubricant level plug and **new** seal, then the lubricant drain/fill plug

and **new** seal. Tighten plugs to a torque of 60 to 84 in. lbs. (7 to 9.5 N·m).



1. Lubricant level plug  
2. Lubricant drain/fill plug

007270

**IMPORTANT:** The recommended gear lubricants are formulated for marine applications. Do not use automotive gear lubricants, engine oils, or any other oil or grease.

## Trim and Tilt

### **CAUTION**

**Correct fluid level must be maintained to ensure operation of the impact protection built into the unit.**

Check reservoir fluid level at least every three years or 300 operating hours.

- System capacity is approximately 15.2 fl. oz. (450 ml).
- Tilt the outboard and engage the tilt support.



1. Tilt support bracket

007636

- Remove filler cap and check fluid level.
- **Single Ram System**—Add *Evinrude/Johnson* Biodegradable TNT Fluid, as needed, to bring level to the bottom of the fill plug threads.

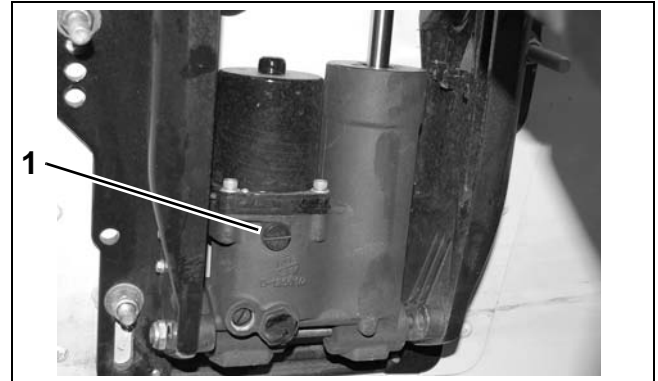

**Single Ram System**  
1. Filler cap

008018

Install the filler cap and tighten to a torque of 45 to 55 in. lbs. (5 to 6 N·m).

- Disengage tilt support.
- Cycle the unit at least five complete cycles to purge all air from the system. When cycling the unit, hold the trim switch ON an additional 5 to 10 seconds after the unit reaches the end of its travel before activating the switch in the opposite direction.

## ROUTINE SERVICE

### SPARK PLUGS

# SPARK PLUGS

Spark plugs should be removed and examined periodically. Replace worn, fouled or damaged spark plugs.

Use only recommended spark plugs with the correct gap setting.

<b>Spark Plug, <i>Champion</i></b>
------------------------------------

QC10WEP @ 0.028 ± 0.003 in. (0.71 mm)
---------------------------------------

- Remove spark plugs and inspect condition.
- Set spark plug gap on new, replacement spark plugs.
- Mark spark plugs for ground electrode orientation.
- Apply *Electrical Grease* to the ribbed portion of the spark plug ceramic and to the opening of the spark plug cover to prevent corrosion.
- Install spark plugs using "indexing" procedure.

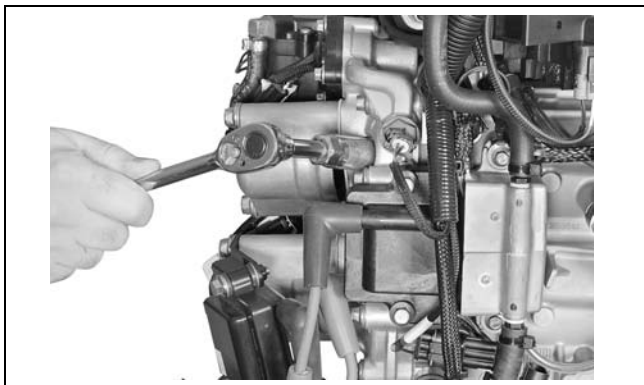

007275

## Indexing

Spark plug indexing positions the ground electrode of the spark plug opposite the fuel injector nozzle.

Put an ink mark on the ceramic of the spark plug in line with the OPEN side of the ground electrode. This mark will be used to orient the spark

plug with the OPEN side of the ground electrode facing the fuel injector.



1. Ink mark
2. Open side

000758

Apply *Triple-Guard* grease to the gasket surface of the spark plug. Install spark plug and tighten to a torque of 15 ft. lbs. (20 N·m).

If the mark is in unshaded area do not tighten anymore.

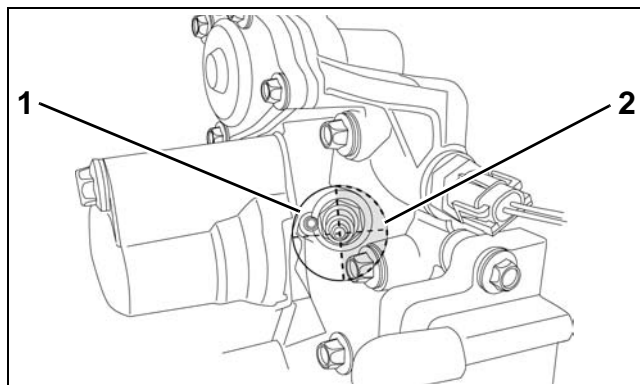

**Spark Plug Indexing Diagram**

1. Unshaded area
2. Shaded area

007437

If the mark is in the shaded area, reset torque wrench to 30 ft. lbs. (41 N·m) and continue to turn until the mark is in the unshaded area.

If the mark does not reach the unshaded area before the torque of 30 ft. lbs. (41 N·m) is reached, the spark plug cannot be indexed for that cylinder. Try another spark plug and repeat the steps above.

## FUEL AND OIL SYSTEMS

Routine replacement of filters reduces the possibility of foreign material restricting the incoming fuel or oil supplies.

Replacement filter elements are available through *Evinrude/Johnson Genuine Parts*.

### Fuel Filter

*Evinrude E-TEC* 15–30 HP outboards are equipped with an in-line fuel filter. Refer to **FUEL COMPONENT SERVICING** on p. 130.

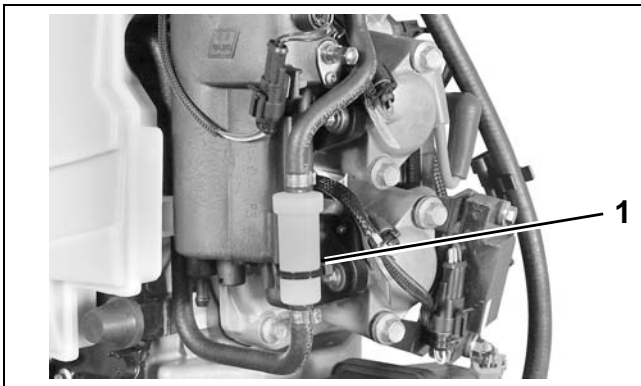

1. *In-line fuel filter*

007273

### Oil Filters and Oil Reservoir

Perform visual inspections to identify oiling system leaks. Make certain the oil tank is filled and oil supply is not contaminated.

### Air Silencer

The air silencer maximizes air flow while minimizing noise.



007274

Routine cleaning of the air silencer is recommended to remove any accumulation of debris.

### Hoses and Connections

Check condition of all hoses and connections in both the fuel and oil systems:

- Visually inspect all components.
- Observe all clamps, hoses, and connections while outboard is running.
- Replace all damaged components.
- Repair all leaks.

#### **WARNING**

**Failure to check for fuel leakage could allow a leak to go undetected, resulting in fire or explosion.**

# ANTI-CORROSION PROTECTION

## Sacrificial Anodes

Galvanic corrosion occurs in fresh or salt water. Salt, brackish, and polluted water can accelerate corrosion. "Sacrificial" anodes are intended to protect the underwater metal components of the outboard from galvanic corrosion.

Manual tilt outboards are equipped with one sacrificial anode. Power tilt outboards are equipped with two sacrificial anodes.

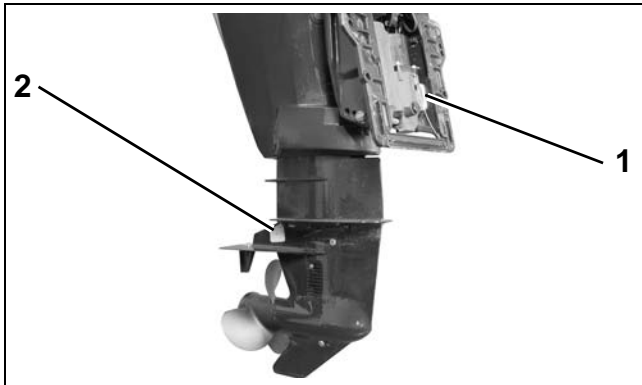

1. Stern bracket anode (Power tilt models only) 007436  
2. Gearcase housing anode

Visually inspect anodes and metal components below water level. Erosion of anodes is normal and indicates the anodes are functioning properly.

**IMPORTANT:** Anodes that are not eroding may not be properly grounded. Anodes and the mounting screws must be clean and tight for effective corrosion protection.

For best anode performance:

- Replace all anodes that have eroded or disintegrated to two-thirds of their original size
- Do not paint or apply protective coatings to anodes or anode fasteners
- Avoid using metal-based antifouling paint on the boat or outboard.

## Testing Procedure – Continuity

Connect ohmmeter leads between engine ground and anode surface.

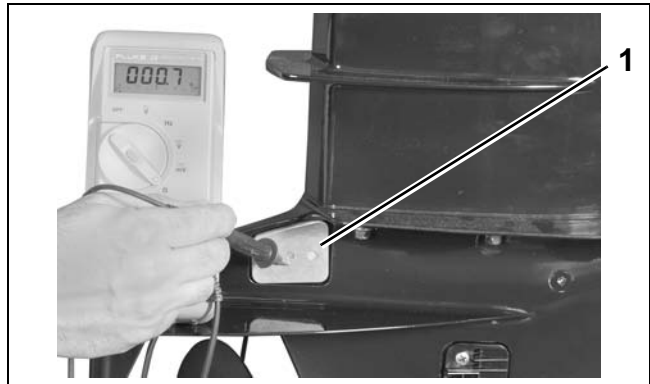

1. Meter lead to anode

007268

The meter should show little or no resistance. If resistance is high, check the following:

- Remove the anode and clean the area where the anode is installed
- Clean the mounting screws
- Install the anode and test again.

## Metallic Component Protection

Protect metal components on outboards from corrosion. Use the following products to minimize corrosion:

- *Anti-Corrosion Spray* provides a heavy, waxy coating to protect components
- *"6 in 1" Multi-Purpose Lubricant* provides a thin film of anti-corrosion protection.

## Exterior Finishes

Maintain the outboard's exterior finish to prevent corrosion and reduce oxidation:

- Use automotive wax to protect the outboard's exterior finish from oxidation.
- Clean regularly using clean water and mild detergent soap.
- Touch-up damage to painted surfaces promptly.



# STORAGE

**IMPORTANT:** DO NOT start outboard without a water supply to the outboard's cooling system. Cooling system and/or powerhead damage could occur.

## Fuel System Treatment

Stabilize the boat's fuel supply with *Evinrude/Johnson 2+4 Fuel Conditioner* following the instructions on the container.

## Internal Engine Treatment

Remove the propeller, attach garden hose to flushing port and turn on water.

*Evinrude E-TEC* models are designed to be self-winterizing using either of the following methods:

**IMPORTANT:** Engine MUST be in NEUTRAL throughout these procedures.

### Throttle Control Method

- Advance throttle control to 1/2 throttle (50%) position and then start the outboard. The outboard will run at idle speed.
- After approximately 15 seconds, move throttle to IDLE position.
- Wait another 15 seconds. At this point, advance throttle to FULL (in neutral). *EMM* LEDs will flash, indicating that outboard is in winterize mode.
- Outboard will automatically go to fast idle and fog itself. Allow outboard to run until it shuts itself off (about one minute).

**IMPORTANT:** If *EMM* LEDs do not flash, or outboard runs above fast idle, immediately turn off outboard and start the procedure again.

### Software Control Method

Winterization can also be run using *Evinrude Diagnostics* software. With the outboard running, start the process at the *Settings/Adjustments* screen and follow the instructions.



1. Winterization start button

008077

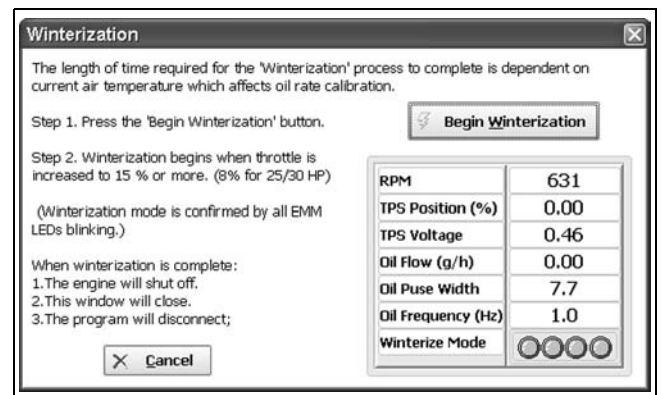

008119

After the outboard shuts itself off, turn key switch OFF, then detach garden hose.

**IMPORTANT:** When finished, leave the outboard in vertical position long enough to completely drain the powerhead.

---

## ROUTINE SERVICE

### PRE-SEASON SERVICE

---

### Additional Recommendations

- Fill oil reservoir.
- Inspect the fuel filter. If there is debris in the fuel filter, it must be replaced.
- Replace gearcase lubricant.
- Remove and inspect propeller.
- Clean and grease propeller shaft.
- Blow water from gearcase speedometer pickup system (gearcase speedometer models only).
- Lubricate all grease fittings and linkages.
- Inspect outboard, steering system, and controls. Replace all damaged and worn components. Refer to manufacturer's and lubrication recommendations.
- Touch up painted surfaces as needed. Coat outer painted surfaces with automotive wax.
- Remove battery(s) from boat. Store in a cool, dry location. Periodically charge battery(s) while stored. Refer to manufacturer's maintenance recommendations when servicing batteries.
- Store outboard in upright (vertical) position.
- Check for fuel leakage.

#### **WARNING**

Failure to check for fuel leakage could allow a leak to go undetected, resulting in fire or explosion.

## PRE-SEASON SERVICE

If the outboard was removed from the boat for storage, make sure it is reinstalled with factory specified hardware. Refer to the **Predelivery and Installation Guide**.

### Outboard Mounting Bolts

- Check and re-tighten outboard mounting bolts to a torque of 40 ft. lbs. (54 N·m).

### Gearcase Lubricant

- Check the lubricant level.
- Inspect gearcase for leaks. If leak is apparent, pressure and vacuum test gearcase.
- Repair gearcase as needed.

### Battery(s)

- Replace batteries that cannot be charged.

### Power Trim and Tilt

- Remove filler cap and check fluid level.
- Inspect the power trim and tilt unit for leaks. Repair as needed.

### Operational Checks

- Refer to **OPERATIONAL CHECKS** on p. 28
- Steering system
- Remote controls
- All other accessories and instrumentation

### Check Oil Injection Tank

- Inspect the oil tank for leaks.

### Check Fuel System

- Inspect entire fuel system for leaks before starting outboard.
- Repair all leaks.

### Water Pump

- Make sure a steady stream of water flows from overboard indicator.

#### **WARNING**

Failure to check for fuel leakage could allow a leak to go undetected, resulting in fire or explosion.

## SUBMERGED ENGINES

Once an outboard has been submerged in fresh or salt water, it must be serviced within three (3) hours of recovery. Immediate service can minimize the corrosive affect that air has on the polished surfaces of the crankshaft, connecting rods, and internal powerhead bearings.

**IMPORTANT:** If outboard cannot be started or serviced immediately, it should be resubmerged in fresh water to avoid exposure to the atmosphere.

### Engine Dropped Overboard (Not Running)

Disconnect the battery cables at the battery.

Rinse powerhead with clean water.

Remove spark plug leads and spark plugs.

Place outboard in horizontal position (cylinder heads down). Slowly rotate flywheel in a clockwise rotation to work all water out of powerhead.

**IMPORTANT:** If sand or silt may have entered the outboard, DO NOT attempt to start it. Disassemble and clean.

Disassemble all electrical connectors. Clean connectors and terminals, and treat with water displacing electrical spray. Apply *Electrical Grease* to terminals prior to reassembly. Coat all exposed solenoid terminals and engine grounds with *Black Neoprene Dip*.

Clean and inspect all electrical components. Replace damaged or corroded components prior to returning the outboard to service. Electric starters should be disassembled, cleaned, flushed with clean water, and treated with water displacing electrical spray prior to reassembly.

Disconnect fuel supply hose from outboard. Drain and clean all fuel hoses, filters, and fuel tanks.

Disconnect oil supply hose and oil return hose from outboard. Drain and clean all oil hoses, filters, and oil tank assemblies.

Refill fuel tank with fresh fuel and oil tank with recommended oil.

Prime oil system and fuel system. Refer to **FUEL SYSTEM PRIMING** on p. 125 and **Oil Supply Priming** on p. 150. Make sure all oil injection hoses are clean and filled with oil.

Make sure high pressure fuel system does not contain water. Flush as needed.

Inject a small amount of outboard lubricant into spark plug holes and install new spark plugs. Refer to **Spark Plug Indexing** on p. 36.

Reinstall all removed or disconnected parts.

Use *Evinrude Diagnostics* software to:

- Initiate Break-in
- Check fuel pump operation
- Check injector operation (fuel and oil)
- Check timing (once outboard is running at full operating temperature)

Run outboard below 1500 RPM for one-half hour.

### Engine Dropped Overboard (Running)

Follow the same procedures as **Engine Dropped Overboard (Not Running)**. However, if there is any binding when the flywheel is rotated, it may indicate a bent connecting rod and no attempt should be made to start the outboard. Powerhead must be disassembled and serviced immediately.

### Engine Dropped Overboard (In Salt Water)

Follow the same procedures used for **Engine Dropped Overboard (Not Running)** and **Engine Dropped Overboard (Running)**. Disassemble and clean outboards that have been submerged in salt water for prolonged periods of time. Clean or replace electrical components as necessary.

### Prolonged Submersion (Fresh or Salt Water)

Outboards that have been dropped overboard and not recovered immediately, must be serviced within three hours of recovery. Follow the same procedures used for **Engine Dropped Overboard (Not Running)** and **Engine Dropped Overboard (Running)**.



# ENGINE COVER SERVICE

## TABLE OF CONTENTS

UPPER COVER SERVICE .....	44
LATCH HOOK INSTALLATION .....	44
LOWER COVER SERVICE .....	45
LOWER COVER REMOVAL .....	45
LOWER COVER INSTALLATION .....	45
LATCH HANDLE INSTALLATION .....	47

# UPPER COVER SERVICE

## Latch Hook Installation

### Rear

Insert threaded bracket into pocket.



1. Bracket

007304

Apply *Ultra-Lock* to screw threads. Place latch into position with roller toward the front. Tighten screws securely.



1. Screws

007305

### Front

Insert bracket into pocket.



1. Bracket

007306

Apply *Ultra-Lock* to screw threads. Place hook into position with opening toward the back. Tighten screws securely.



1. Screws

007307

## LOWER COVER SERVICE

### Lower Cover Removal

Remove cable entry cover screws, cover and cable entry grommets.

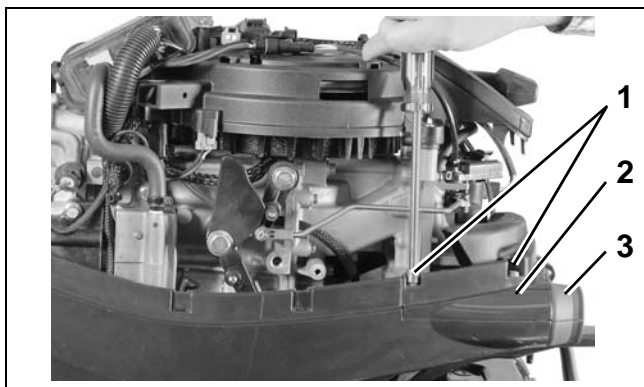

1. Cable entry cover screws
2. Cable entry cover
3. Cable entry grommets

007308

Remove lower engine cover screws.



1. Lower cover screws

007309

### Lower Cover Installation

Installation of lower motor covers will be easier if the following steps are performed in order:

- Install air silencer on throttle body.
- Install fuel hose on fuel connector fitting. Secure with new *Oetiker* clamp. Place port cover on outboard. If equipped, route battery and trim cables through grommet opening.
- Place starboard side cover into position on outboard.

**3**



1. Grommet opening
2. Battery cable

007310

Start the screw below the exhaust relief grommet first. Tighten just enough to hold the grommet in place.



1. Start this screw first
2. Exhaust relief grommet

007311

## ENGINE COVER SERVICE

### LOWER COVER SERVICE

Start the bottom front screw next to draw cover halves together.



1. Start this screw second

007312

Install the front latch sleeve and start the top front screw next to draw cover halves together.

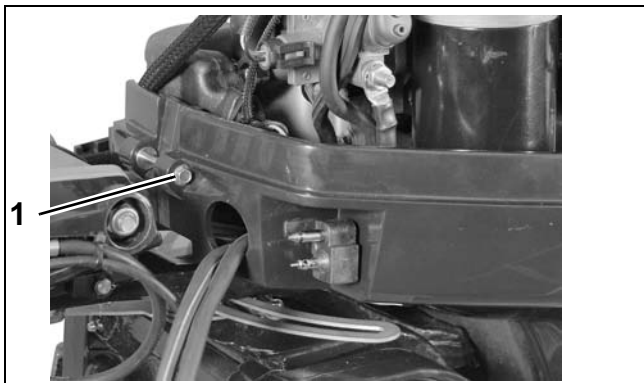

1. Start this screw third

007310

Install remaining cover screws and tighten all screws to 24 to 36 in. lbs. (3 to 4 N·m).



1. Lower cover screws

007309

Install cable entry cover grommets, cable entry cover and cable entry cover screws. Tighten screws to 24 to 36 in. lbs. (3 to 4 N·m).

Install trim and battery cable grommet on port cover.



1. Grommet
2. Trim cable (if equipped)
3. Battery cable

007313



### Latch Handle Installation

Apply a light coat of *Triple-Guard* grease to latch handle shaft. Insert handle into lower cover.

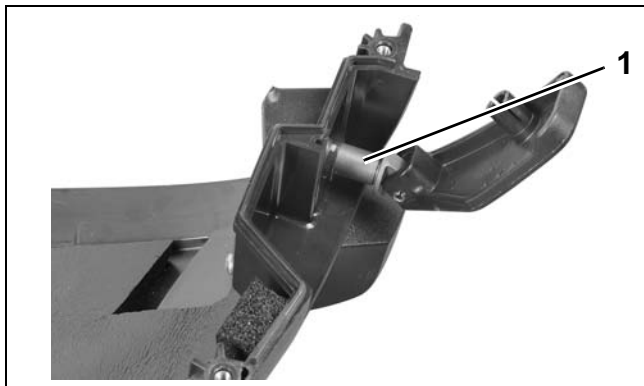

1. Triple-Guard grease

007314

Apply *Ultra-Lock* to screw threads. Place spring washer and hook into position and tighten screw to a torque of 180 in. lbs. (20 N·m).

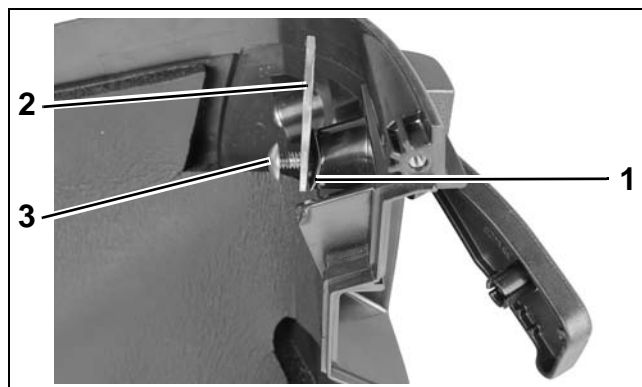

1. Spring washer  
2. Hook  
3. Screw

007315

**3**

**NOTES**

**Technician's Notes**

---

---

---

---

---

---

---

---

---

---

---

---

---

---

---

---

---

---

---

---

---

---

---

---

---

---

**Related Documents**

<b>Bulletins</b>	
<b>Instruction Sheets</b>	
<b>Other</b>	

# ENGINE MANAGEMENT MODULE (*EMM*)

## TABLE OF CONTENTS

DESCRIPTION .....	50
<i>EMM</i> FUNCTIONS .....	50
<i>EMM</i> CONNECTIONS .....	50
LED INDICATORS .....	50
<b><i>EMM</i> INPUTS AND OUTPUTS DIAGRAM .....</b>	<b>51</b>
<b>INTERNAL SENSORS .....</b>	<b>52</b>
<i>EMM</i> TEMPERATURE SENSOR .....	52
55 V CIRCUIT SENSOR .....	52
12 V CIRCUIT SENSOR .....	52
5 V CIRCUIT SENSOR .....	53
BAROMETRIC PRESSURE SENSOR .....	53
<b>EXTERNAL SENSORS .....</b>	<b>53</b>
AIR TEMPERATURE SENSOR .....	53
ENGINE TEMPERATURE SENSOR .....	54
LOW OIL SWITCH .....	54
THROTTLE POSITION SENSOR .....	55
CRANKSHAFT POSITION SENSOR .....	55
NEUTRAL SWITCH .....	55
<b>INTERNAL EMM FUNCTIONS .....</b>	<b>56</b>
<b>ENGINE MONITOR SYSTEM .....</b>	<b>56</b>
<b>S.A.F.E. WARNING SYSTEM .....</b>	<b>57</b>
<b>SHUTDOWN MODE .....</b>	<b>58</b>
<b>DIAGNOSTIC SOFTWARE FUNCTIONS .....</b>	<b>58</b>
COMMUNICATION .....	58
STATIC INFORMATION .....	59
DYNAMIC INFORMATION .....	60
STORED SERVICE CODES (FAULTS) .....	60
HARD FAULTS .....	60
PERSISTENT FAULTS .....	60
STATIC TESTS .....	60
DYNAMIC TESTS .....	61
OIL CONTROL SETTINGS .....	62
TILLER/REMOTE PROGRAMMING .....	62
IGNITION TIMING .....	63
TPS CALIBRATION .....	63
FUEL INJECTOR SERVICING .....	64
REPORTS .....	64
SOFTWARE REPLACEMENT .....	65
<i>EMM</i> TRANSFER .....	65
<b><i>EMM</i> SERVICING .....</b>	<b>66</b>
REMOVAL .....	66
INSTALLATION .....	66

## ENGINE MANAGEMENT MODULE (EMM) DESCRIPTION

### DESCRIPTION

The Engine Management Module (*EMM*) is a water-cooled engine controller. It controls many outboard systems including alternator output for the 55 V circuits. Operating voltage is supplied to the *EMM* by the stator.

This section discusses the functions of the *EMM* and its various internal and external sensors. It also describes using *Evinrude Diagnostics* software to retrieve and adjust service information stored in the *EMM*.

### EMM Functions

The *EMM* controls the following processes and functions:

- Alternator output; 55 V
- Fuel and ignition timing and duration
- Fuel injector activation
- Oil injector pump activation
- Electric fuel pump control
- Idle speed control
- RPM limiter
- Electrical circuit monitoring
- Service code creation and storage
- Warning system activation
- ROM verification, self-test
- Choke-less cold starting
- Output of diagnostic data
- Tachometer signal
- RPM profile and engine hours
- Oiling ratios

### EMM Connections

**IMPORTANT:** *EMM* connections and wiring must be clean and tight. Improper electrical connections can damage the *EMM*. DO NOT run the outboard with loose or disconnected wiring.

Make sure *EMM* connections are clean and tight.

- Engine wire harness to *EMM* connector; J1-A
- Stator to *EMM* connection; one 4-pin AMP connector.

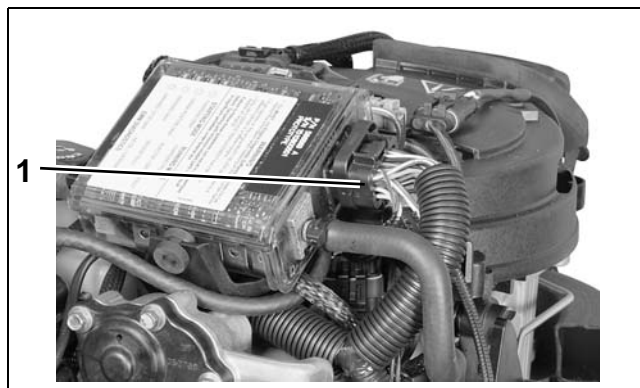

1. J1-A connector

007353

### LED Indicators

The *EMM* has four LED indicators located on top of the circuit board that provide useful information about the status of the system.

**IMPORTANT:** LED 1 is toward the center of the outboard (closest to *EMM* J1-A connector).

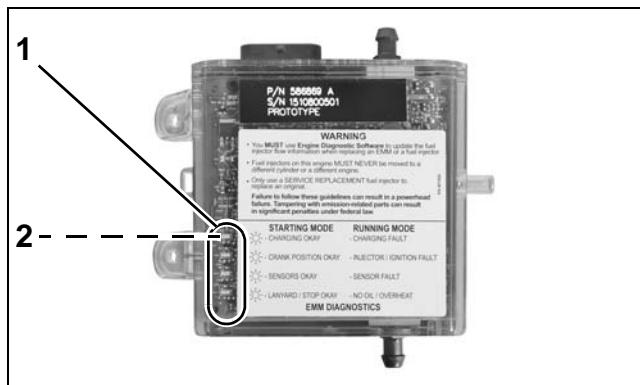

1. LED indicators  
2. LED 1

007382

When the ignition key is turned ON, LEDs 3 and 4 should light, indicating that sensor circuits and the stop circuit are working.

As the outboard is being started, all four LEDs should light and then go off in sequence. If any of the LEDs does NOT light during starting, refer to **EMM LED INDICATORS** on p. 71.

When the outboard is running, all LEDs should be off. If any LED is lighted while the outboard is running, refer to **EMM LED INDICATORS** on p. 71.

# EMM INPUTS AND OUTPUTS DIAGRAM

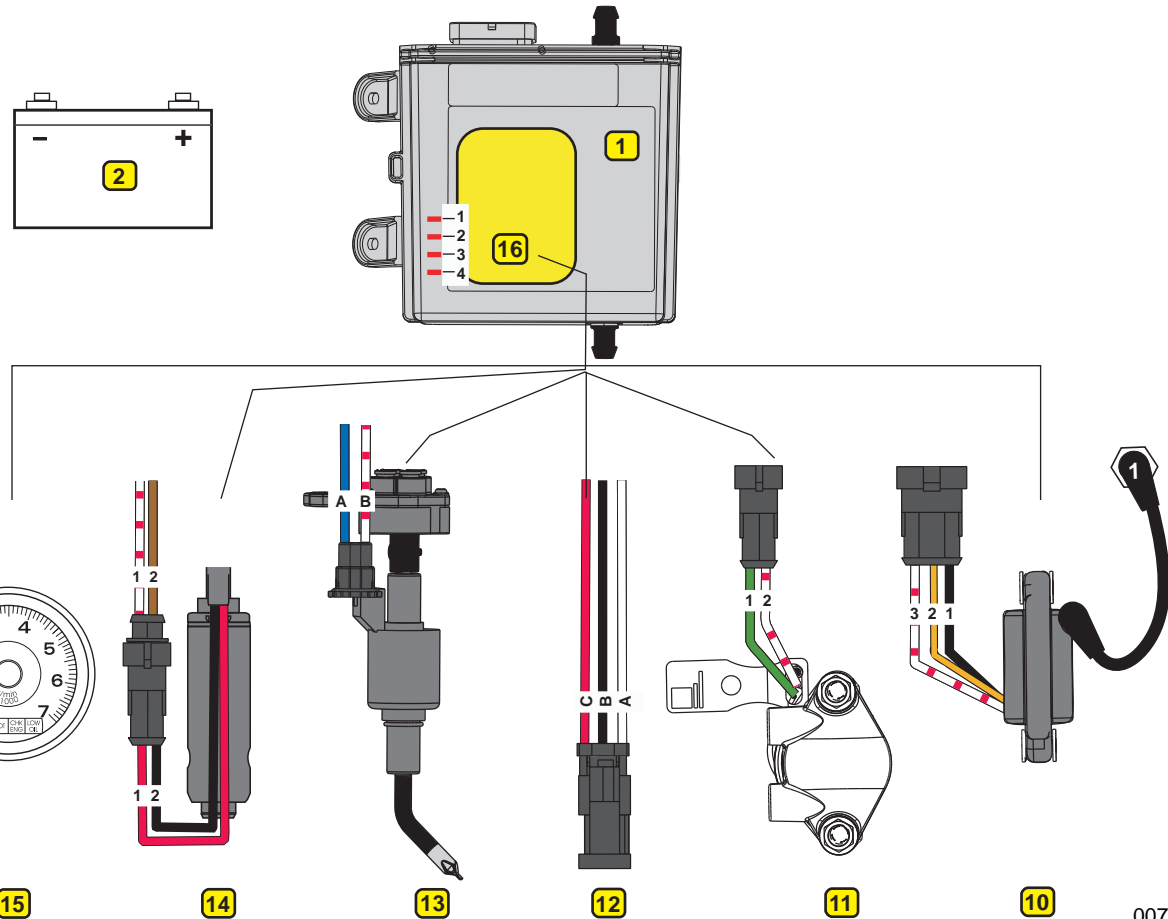
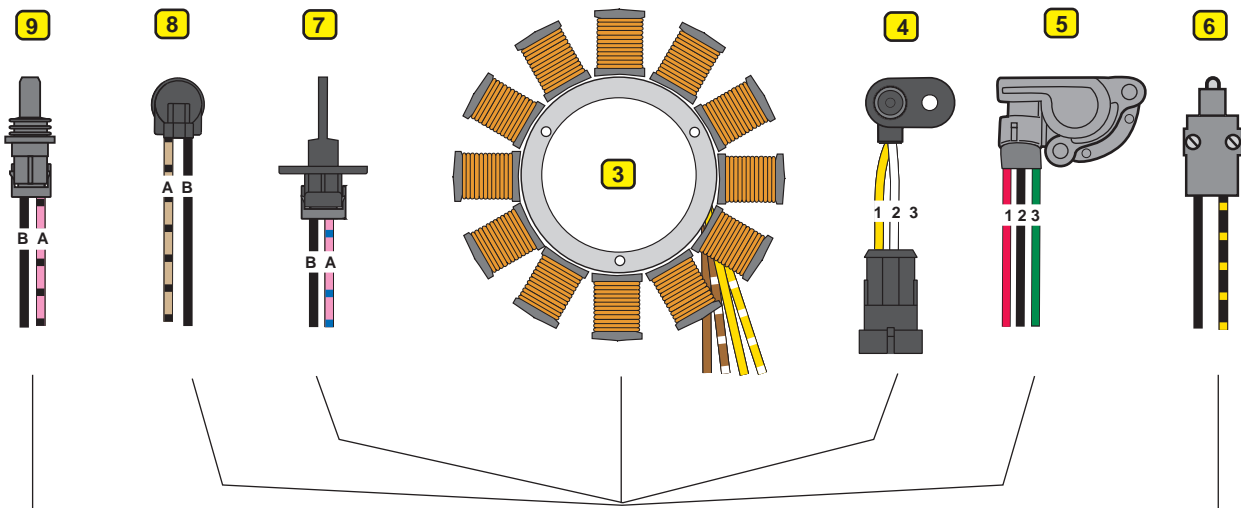

- 1. Engine Management Module (EMM)
- 2. Battery (12 volt)
- 3. Stator
- 4. Crankshaft Position Sensor (CPS)
- 5. Throttle Position Sensor (TPS)
- 6. Neutral Switch

- 7. Air Temperature Sensor (AT)
- 8. Oil Level Switch
- 9. Engine Temperature Sensor
- 10. Ignition Coil
- 11. Fuel Injector
- 12. Diagnostic Connector

- 13. Oil Injection Pump and Manifold
- 14. Fuel Pump (high pressure)
- 15. Tachometer
- 16. LED Indicators

007383

## ENGINE MANAGEMENT MODULE (EMM)

### INTERNAL SENSORS

## INTERNAL SENSORS

Sensor inputs and internal *EMM* controllers are used to control outboard operation. Use *Evinrude Diagnostics* software to troubleshoot the sensors. Refer to the **EMM Service Code Chart** at the back of this manual for a complete list of all engine fault codes.

Internal sensors are NOT serviceable. Reprogramming or replacement may be required to resolve internal *EMM* issues.

### EMM Temperature Sensor

Monitors the temperature of the fuel injector driver circuits.

If the *EMM* temperature exceeds 194°F (90°C) or the circuit fails, the *EMM*:

Activates <i>S.A.F.E.</i>
Stores service code 25
<i>EMM</i> LED 4: ON (Running)

If *EMM* temperature exceeds 212°F (100°C) or the circuit fails, the *EMM*:

Activates SHUTDOWN
Stores service code 29
<i>EMM</i> LED 4: FLASHING

**IMPORTANT:** The outboard will not restart until the engine cools below 212°F (100°C) and the *EMM* temperature returns to normal. Refer to **SHUTDOWN MODE** on p. 58.

If *EMM* temperature is less than -22°F (-30°C) or the circuit fails, the *EMM*:

Stores service code 24
<i>EMM</i> LED 3: OFF (Cranking)
<i>EMM</i> LED 3: ON (Running)

If sensor reads less than -71°F (-57.4°C) or greater than 313°F (156°C), a sensor circuit fault is detected and the *EMM*:

Stores service code 23
<i>EMM</i> LED 3: OFF (Cranking)
<i>EMM</i> LED 3: ON (Running)

### 55 V Circuit Sensor

Monitors the *EMM*'s 55 V alternator circuit.

If system voltage exceeds 57 volts, the *EMM*:

Activates <i>S.A.F.E.</i>
Stores service code 18
<i>EMM</i> LED 1: ON (Running)

If system voltage is less than 45 V, the *EMM*:

Activates <i>S.A.F.E.</i>
Stores service code 17
<i>EMM</i> LED 1: ON (Running)

### 12 V Circuit Sensor

Monitors the *EMM*'s 12 V alternator circuit.

If battery voltage exceeds 15.5 volts, the *EMM*:

Stores service code 27
<i>EMM</i> LED 1: ON (Running)

If battery voltage is less than 12.5 V, the *EMM*:

Stores service code 26
<i>EMM</i> LED 1: ON (Running)

## 5 V Circuit Sensor

Monitors the *EMM*'s 5 V sensor circuit.

If sensor voltage is less than 4.75 volts, the *EMM*:

Stores service code 78
<i>EMM</i> LED 3: OFF (Cranking)
<i>EMM</i> LED 3: ON (Running)

## Barometric Pressure Sensor

Supplies the *EMM* with barometric pressure reading to compensate for changes in altitude and air density.

If the BP sensor reads less than 13 KPa or greater than 119.0 KPa, or the sensor or circuit fails, the *EMM*:

Stores service code 44
------------------------

If the BP sensor reads less than 70 KPa, the *EMM*:

Stores a service code 45
--------------------------

If the BP sensor reads greater than 105 KPa, the *EMM*:

Stores service code 46
------------------------

## EXTERNAL SENSORS

Sensor inputs and internal *EMM* controllers are used to control outboard operation. Use *Evinrude Diagnostics* software to troubleshoot the sensors. Refer to the ***EMM* Service Code Chart** at the back of this manual for a complete list of all engine fault codes.

The *EMM* provides a 5 V DC signal for sensor circuits. It monitors all sensor voltage inputs and compares them to predetermined acceptable ranges. Inputs that fall outside of the acceptable range create service codes.

### Air Temperature Sensor

The air temperature sensor monitors the air temperature at the throttle body.

If the AT sensor voltage is out of the expected range, or the sensor or circuit fails, the *EMM*:

Stores service code 47, 48, or 49
<i>EMM</i> LED 3: OFF (Cranking)
<i>EMM</i> LED 3: ON (Running)

## ENGINE MANAGEMENT MODULE (EMM)

### EXTERNAL SENSORS

#### Engine Temperature Sensor

Monitors cylinder head temperature.

If cylinder head temperature exceeds 212° F (100° C) below 3500 RPM, the *EMM*:

Activates <i>S.A.F.E.</i>
Stores service code 40
<i>EMM</i> LED 4: ON (Running)

If cylinder head temperature exceeds 194° F (90° C) above 3500 RPM, the *EMM*:

Activates <i>S.A.F.E.</i>
Stores service code 43
<i>EMM</i> LED 4: ON (Running)

If cylinder head temperature exceeds 248°F (120°C), the *EMM*:

Activates SHUTDOWN
Stores service code 31
<i>EMM</i> LED 4: FLASHING

The outboard will not restart after a temperature related SHUTDOWN until the engine temperature returns to normal. Refer to **SHUTDOWN MODE** on p. 58.

If sensor values are less than -15°F (-26.1°C) or greater than 332°F (166.5°C), the *EMM*:

Stores service code 41
<i>EMM</i> LED 3: OFF (Cranking)
<i>EMM</i> LED 3: ON (Running)

If sensor values are below -4°F (-20°C), the *EMM*:

Stores service code 42
<i>EMM</i> LED 3: OFF (Cranking)
<i>EMM</i> LED 3: ON (Running)

If cylinder head does not reach operating temperature (104°F / 40°C below 2300 RPM) in 10 minutes, the *EMM*:

Stores service code 58
<i>EMM</i> LED 3: OFF (Cranking)
<i>EMM</i> LED 3: ON (Running)

#### Low Oil Switch

The low oil switch monitors the oil level in the oil tank.

If the oil level falls below one-quarter capacity, the *EMM* begins counting oil pump pulse cycles. When it reaches 1000 pulses, the *EMM* signals:

Engine Monitor LOW OIL display: ON
------------------------------------

After LOW OIL is displayed, the *EMM* counts oil pump pulse cycles again. When it reaches 6700 pulses, the *EMM*:

Activates <i>S.A.F.E.</i>
Stores service code 117
<i>EMM</i> LED 4: ON (Running)
Engine Monitor LOW OIL display: ON

To recover from *S.A.F.E.* mode:

- Oil level must be above one-quarter
- The warning resets after three oil pump pulse cycles when the outboard has been stopped and restarted.

If outboard has been run for more than 3 hours with NO OIL faults (codes 34 & 117), the *EMM*

Activates SHUTDOWN
Stores service code 33
<i>EMM</i> LED 4: FLASHING
Engine Monitor LOW OIL display: FLASHING

If the *EMM* detects the low oil sensor circuit is open, the *EMM*:

Activates <i>S.A.F.E.</i>
Stores service code 120
<i>EMM</i> LED 4: ON (Running)



## Throttle Position Sensor

The throttle position sensor receives a voltage signal from the *EMM*. As the throttle lever is rotated, the *EMM* receives a return voltage signal through a second wire. This signal increases as the TPS lever is advanced. A third wire provides a ground circuit back to the *EMM*.

If TPS voltage is greater than 1.71 volts when the key is turned to ON, or the recoil starter is pulled, the *EMM*:

Creates service code 11
-------------------------

If the outboard starts, the code is stored.

If code 11 is present as both a Hard Fault and a Stored Fault, refer to **Control Cable Installation** on p. 18.

For tiller models, refer to **Control Cable Installation** on p. 240.

If the TPS or TPS circuit fails (below 0.14 volts or above 4.92 volts), the *EMM*:

Stores service code 12
Limits engine RPM to IDLE
<i>EMM</i> LED 3: OFF (Cranking)
<i>EMM</i> LED 3: ON (Running)

**IMPORTANT:** When a TPS circuit fault has been detected, the outboard will not accelerate above idle speed. To reset, stop the outboard and correct the fault.

If the TPS circuit reads below 0.2 volts, the *EMM*:

Stores service code 13
<i>EMM</i> LED 3: OFF (Cranking)
<i>EMM</i> LED 3: ON (Running)

If the TPS circuit reads above 4.85 volts, the *EMM*:

Stores service code 14
<i>EMM</i> LED 3: OFF (Cranking)
<i>EMM</i> LED 3: ON (Running)

## Crankshaft Position Sensor

Ribs spaced on the flywheel mark crankshaft position. As the ribs pass the magnetic field of the CPS, an AC voltage signal is generated. The *EMM* uses this signal to identify crankshaft position and speed, generate a tachometer signal, and control fuel and ignition timing.

If the sensor is damaged or the signal is intermittent (10 occurrences), the *EMM*:

Stores service code 16
<i>EMM</i> LED 2: OFF (Cranking)
<i>EMM</i> LED 3: ON (Running)

Approximate air gap between CPS and flywheel encoder ribs is .073 (1.85 mm).

Use the *Evinrude Diagnostics* software *Monitor* screen to check CPS operation. The software should show an RPM reading while the outboard is cranking. If the CPS or its circuit fails, no RPM reading will appear and the outboard cannot run.

## Neutral Switch

The powerhead mounted neutral switch controls a ground signal from the *EMM* to indicate shift linkage position. This allows the *EMM* to control idle speed variations and start in gear protection. Fuel and ignition functions are turned off if the neutral switch is not closed.

If the starter is cranked while the outboard is in gear, or if the switch fails, the *EMM*:

Stores service code 19
<i>EMM</i> LED 3: OFF (Cranking)

The *Monitor* screen of the diagnostics software displays switch position, NEUTRAL or IN GEAR. Make sure switch is operating properly.

## INTERNAL *EMM* FUNCTIONS

### ROM Verification

The *EMM* performs a self-test of programming every time it is turned ON. Service code 15 indicates a programming (software) issue. Reprogram the *EMM* with the correct software program to correct the problem.

### Idle Controller

The idle controller reacts to engine operating conditions. Fuel and ignition timings are altered to maintain a specific RPM when engine is cold or warm. The controller is inactive when TPS is advanced from idle position.

### RPM Limiter

This feature of *EMM* programming prevents engine damage due to excessive RPM. At 6250 RPM, fuel and ignition to the cylinders is shut off. Normal operation resumes when engine RPM returns to the specified range.

### Neutral RPM Limiter

This feature prevents engine damage due to excessive RPM if accelerated in NEUTRAL. Neutral engine speed is limited to 1100 RPM.

### Engine Monitor and Warning Systems

Refer to **ENGINE MONITOR SYSTEM** on p. 56.

Refer to **S.A.F.E. WARNING SYSTEM** on p. 57.

Refer to **SHUTDOWN MODE** on p. 58.

### Fault Code Creation and Storage

Refer to the *EMM Service Code Chart* at the back of this manual for a complete list of all engine fault codes.

## ENGINE MONITOR SYSTEM

An optional engine monitoring system warns the operator of conditions that could damage the outboard. The system includes a LOW OIL switch on the oil tank, a warning horn, a dash-mounted display, and related wiring.

The outboard's *EMM* sends information about monitored functions to:

- A *SystemCheck* gauge
- *EMM* LED indicators

**IMPORTANT:** *Evinrude E-TEC* 15–30 HP models provide LOW OIL warning ONLY.

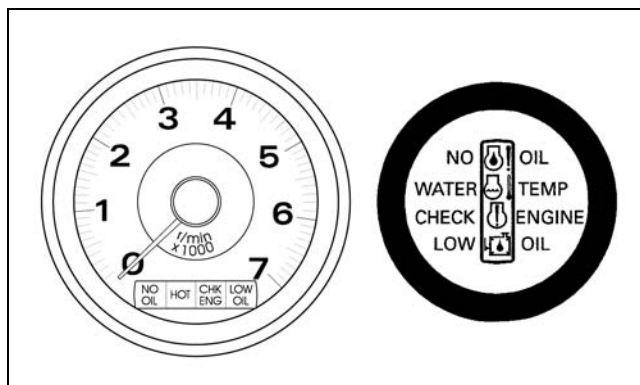

Typical *SystemCheck* gauges

007384

The *EMM* activates the warning horn and gauge displays as follows:

- LOW OIL means that oil in the tank is at reserve level (about 1/4 full).

For all other warnings, refer to **EMM LED INDICATORS** on p. 71.

Refer to the *EMM Service Code Chart* at the back of this manual for a complete list of all fault codes.

## System Self-Test

During engine start-up, pause with the key switch in the ON position. The horn self-tests by sounding a half-second beep. *SystemCheck* gauges self-test by turning the indicator lights on simultaneously, then off in sequence.

## Service Mode

*SystemCheck* goes into a service mode if the key is left ON after self-test (engine NOT running). All light circuits and sensors are active, but the horn is not. Grounding the appropriate light circuit wire will turn the light on, but the horn will not sound. Refer to **SystemCheck CIRCUIT TESTS** on p. 101.

## Engine Running

All warning circuits are active when the engine is running. The horn circuit is active when engine speed exceeds 500 RPM.

Engine monitor warnings activate the horn for 10 seconds and the appropriate gauge light for a minimum of 30 seconds. If the failure is momentary (for example, oil moving in the tank), the light will remain ON for the full 30 seconds before going out. If the fault continues, the light remains ON until the key is turned OFF or the failure is corrected. The warning will reoccur at the next start-up if the problem is not corrected.

# S.A.F.E. WARNING SYSTEM

The *S.A.F.E.* (*Speed Adjusting Failsafe Electronics*) warning system alerts the operator and protects against engine damage from the following abnormal conditions:

Code 17	Alternator 55 V below expected range
Code 18	Alternator 55 V above expected range
Code 25	<i>EMM</i> temperature above expected range
Code 34	Oil injector open circuit
Code 40	Engine overheat low speed
Code 43	Cylinder head temperature above expected range
Code 117	Critical LOW OIL Detected
Code 120	LOW OIL switch open circuit detected

## Activation

When one of these conditions occurs, the *EMM* interrupts fuel injector and ignition operation, reducing engine speed to 1200 RPM. The warning horn sounds and an Engine Monitor message displays. When *S.A.F.E.* is active, the engine will run normally below 1200 RPM. Above 1200 RPM, the engine will shake excessively.

## Recovery

The engine will operate in *S.A.F.E.* as long as the fault condition exists. To recover normal operation, two conditions must be met:

- Sensor or switch readings must be back within limits
- The *EMM* must be reset—stop and restart

## ENGINE MANAGEMENT MODULE (EMM) SHUTDOWN MODE

### SHUTDOWN MODE

Outboard “shutdown” will occur if specific faults are detected by the *EMM*:

Code 29	Excessive <i>EMM</i> temperature
Code 31	Excessive engine temperature
Code 33	Excessive NO OIL condition
Code 57	High RPM with low TPS setting

Code 57 occurs when the *EMM* detects abnormally high RPM relative to the TPS position. This condition could be caused by uncontrolled fuel entering the combustion cycle. Before removing the code and STARTING the outboard, find and repair the cause.

- Perform **Fuel System Pressure Test** on p. 126. Check for external fuel leakage that could allow fuel and/or vapor to enter the engine through the air intake.
- Check for internal fuel leakage from a leaking injector or vapor separator vent hose.

#### WARNING

If the engine shuts OFF and the “CHECK ENGINE” light or *EMM* SENSOR FAULT LED is flashing, the engine cannot be restarted. A hazardous fuel condition may exist which could result in a fire or explosion.

### Recovery

To recover from shutdown mode, the *EMM* must NOT detect the related fault at start-up. The outboard will not restart until the cause of the stored service code is resolved (code 29 and 31) and the code is cleared using diagnostics software (code 33 and 57). Then, the *EMM* must be turned OFF and ON again.

**IMPORTANT:** Shutdown related to code 57 or 33 requires the removal of the stored service code. Use *Evinrude Diagnostics* software to clear a code 57 or 33.

### DIAGNOSTIC SOFTWARE FUNCTIONS

The *EMM* stores valuable information about the outboard and its running history. This information can be used for troubleshooting, for checking parts information, and for making adjustments to the system.

Use *Evinrude Diagnostics* software, version 4.5 or higher, and a laptop computer to access program information.

**IMPORTANT:** For software help, refer to the “Help” menu in the software.

### Communication

Locate the diagnostic connector on the engine. Remove the cover and install the Diagnostic Interface Cable, P/N 437955.

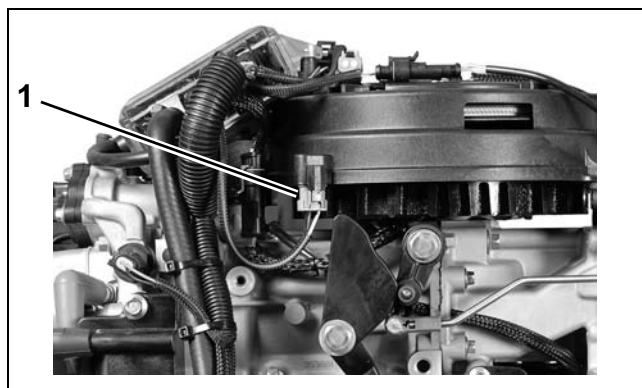

1. Diagnostic connector

007405

Connect the 9-pin connector of the interface cable directly to the computer’s serial port.

The *EMM* must turn ON before it will communicate with the computer.

#### **ELECTRIC START MODELS**

Power is normally supplied to the *EMM* when the key switch is ON. Switched B+ (12 V) enters the *EMM* at pin 3 (purple) of the *EMM* J1-A connector.

The *EMM* is also turned ON when it begins to receive AC voltage from the stator while the outboard is being cranked.

## ROPE START MODELS

Diagnostic communications on non-running rope start models requires that power is supplied to the *EMM*.

Use Diagnostic Power Supply Tool, P/N 587005, to supply power to the *EMM*. The power supply uses internal 9-volt batteries.

Connect Power Supply Tool to the engine harness key/stop switch connector. Turn toggle switch to the ON position to power the *EMM*.

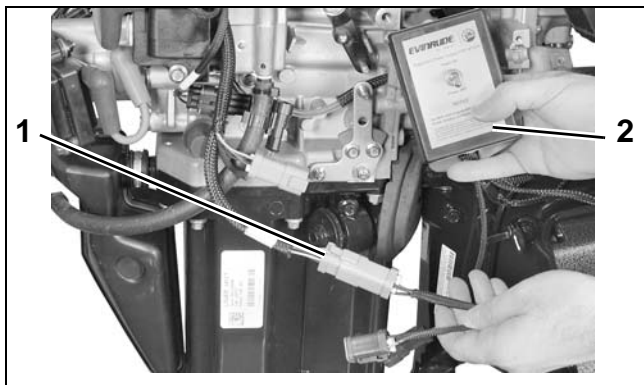

1. Engine harness key switch connector 007385  
2. Power supply tool

**IMPORTANT:** Static tests require more power than the internal batteries of the tool can provide. Static tests performed using only the internal power supply batteries will produce false results.

Use Accessory Power Cable Kit, P/N 5008092, to connect an external 12 volt battery to the Power Supply Tool when performing these static tests:

- Fuel pump
- Fuel injector
- Ignition coil
- Oil injector



Accessory power cables 007386

## Static Information

Static information is viewed when the outboard is NOT running. This includes manufacturing information.

The outboard model and serial numbers displayed on the *Identity* screen must match the identification label on the outboard swivel bracket.

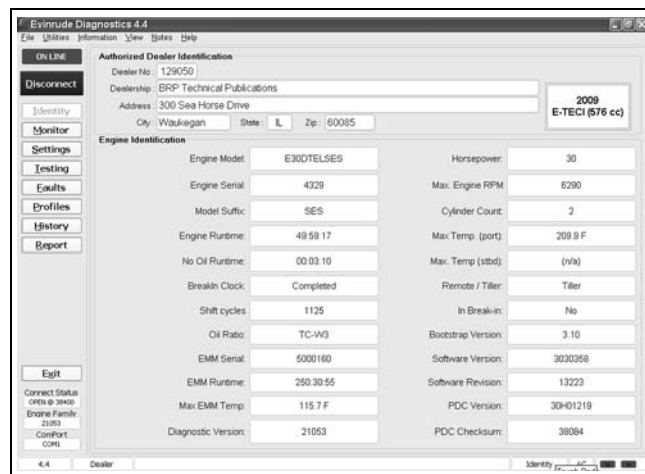

Identity Screen 008136

The serial number and cylinder location displayed on the *Injector Coefficients* screen must match the actual cylinder placement for each injector.

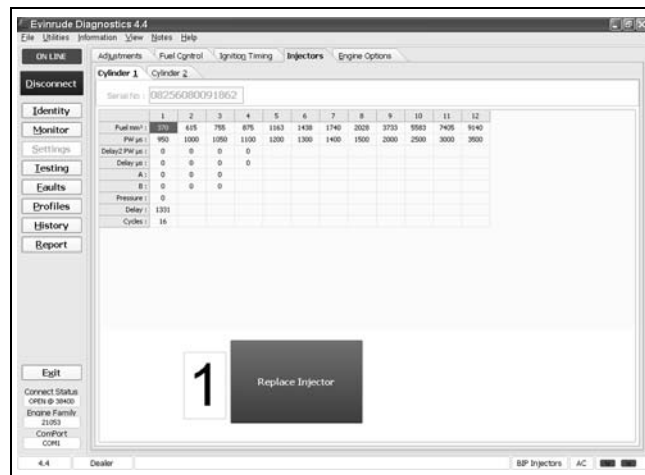

Injector Coefficients Screen 008137

4

# ENGINE MANAGEMENT MODULE (EMM) DIAGNOSTIC SOFTWARE FUNCTIONS

## Dynamic Information

Dynamic information is viewed while the outboard is running. Changes in data, such as voltages or temperatures, are shown as they happen.



Monitor Screen 008137

## Hard Faults

A hard fault is a service code that currently exists. Hard faults become stored faults only if the outboard is running.

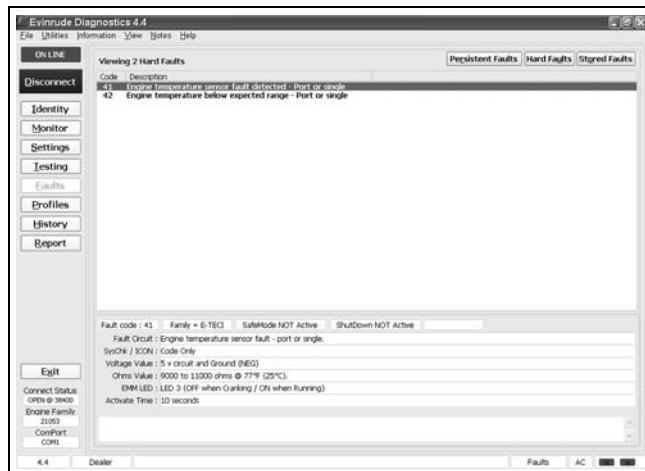

Hard Faults Review Screen 008138

## Stored Service Codes (Faults)

Service codes are stored if an abnormal condition occurs while the outboard is running.

The *Stored Faults* screen of the diagnostics software shows the code number, the number of times the event occurred, and operating hours of first and last occurrences.

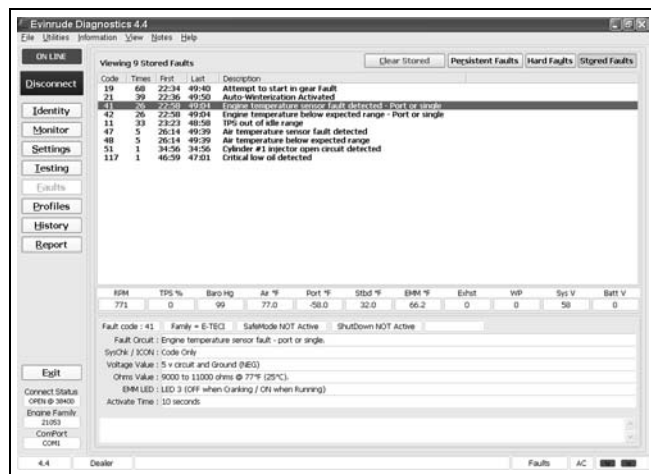

Stored Faults Review Screen 008139

## Persistent Faults

The *Persistent Faults* screen keeps a history of all previously stored codes, including code number, the number of times the event occurred, and operating hours of the last occurrence.

Persistent faults cannot be erased.

## Static Tests

Static Tests allow diagnostic testing of system components while the outboard is NOT running.

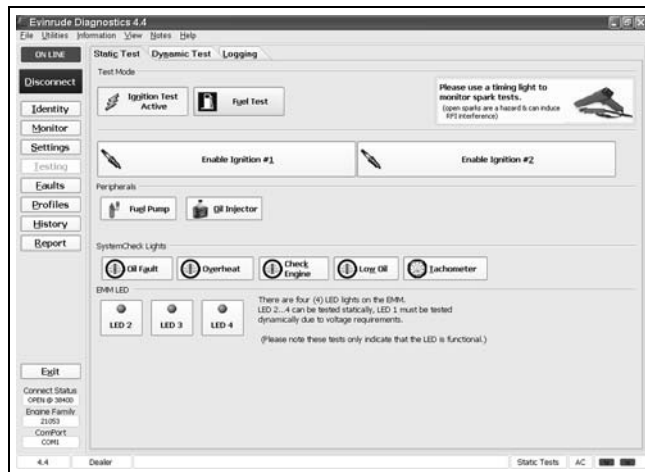

Static Tests Screen 008140

## Ignition Test

Use the diagnostics software to test each ignition circuit. Refer to **Static Ignition Test** on p. 75.

## Fuel Test

Use the diagnostics software to test each fuel injector circuit. Refer to **Fuel Injector Static Test** on p. 78.

## Oil Injector

Use the diagnostics software to test the oil injection pump circuit. Refer to **OILING SYSTEM TESTS** on p. 151.

## Fuel Pump

Use the diagnostics software to test the fuel pump circuit. Refer to **Fuel Pump Static Test** on p. 78.

## Tachometer

This test is used to check operation of the tachometer circuit.

## Dynamic Tests

Dynamic tests are performed with the outboard running.



Dynamic Tests Screen

008141

4

## Ignition Test

This test momentarily disables the ignition and fuel injection circuits to one cylinder. By dropping one cylinder, RPM and running quality changes can be observed. Refer to **DYNAMIC TESTS** on p. 70.

## Fuel Test

This test momentarily disables one fuel injector circuit. By dropping one cylinder, RPM and running quality changes can be observed. Refer to **DYNAMIC TESTS** on p. 70.

## Prime Oil

This test is used to cycle the oil injection pump for priming the oiling system. Perform this test with outboard running to activate oil injection pump.

# ENGINE MANAGEMENT MODULE (EMM) DIAGNOSTIC SOFTWARE FUNCTIONS

## Oil Control Settings

### Set Oil Type

The TC-W3 oil type setting is the standard setting for all outboards. Set TC-W3 for:

- Operation with all TC-W3 outboard oils including *XD30*, *XD50*, or *XD100*
- Applications requiring maximum lubrication
- Extreme applications (racing or harsh conditions).

The *XD100* setting provides an option to run the outboard at a reduced oil injection rate. This setting **REQUIRES** the use of *Evinrude XD100* outboard lubricant and is not recommended for all applications.

Use the *XD100* setting for:

- Conventional use (runabouts, cruisers)
- Moderate applications.



1. Oil control setting 008142

**⚠ CAUTION**

Running an *Evinrude E-TEC* outboard on other grades of oil while set to the *XD100* oil ratio will result in increased engine wear and shortened outboard life.

## Powerhead Break-In

Use the diagnostics software to start break-in oiling after a powerhead rebuild. The break-in oiling program runs for two hours of outboard operation, above 2000 RPM.



1. Break-in oil setting 008142

## Tiller/Remote Programming

This feature controls the start in gear protection function of the neutral switch. Tiller operated models, including remote models with an installed tiller conversion kit, **MUST** be set to TILLER.

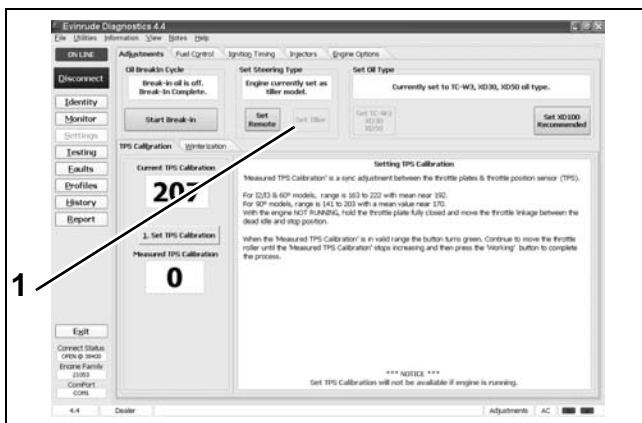

1. Starter mode setting 008142



## Ignition Timing

Use the *Ignition Timing* screen to check and adjust *EMM* timing. *EMM* timing must be synchronized to crankshaft position.

Refer to **TIMING ADJUSTMENTS** on p. 106.

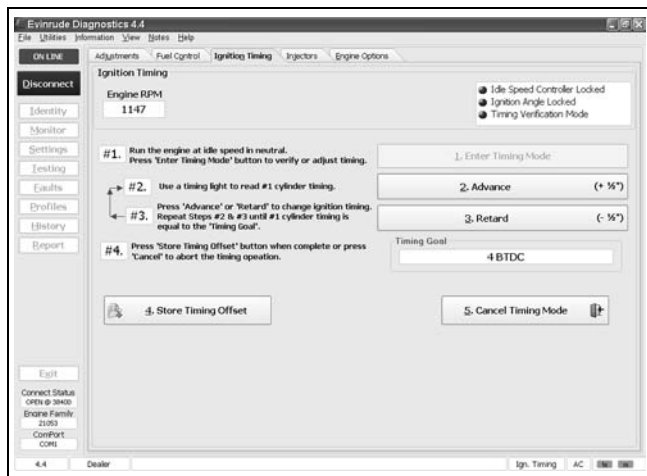

008143

Check timing after any of the following procedures:

- Powerhead replacement
- Crankshaft replacement
- Flywheel removal or replacement
- CPS replacement
- *EMM* replacement
- *EMM* software replacement

**IMPORTANT:** Make sure the outboard reaches operating temperature before making adjustments.

## TPS Calibration

TPS Calibration synchronizes throttle plate opening with throttle position sensor voltage.

Refer to **TPS Calibration** on p. 106.

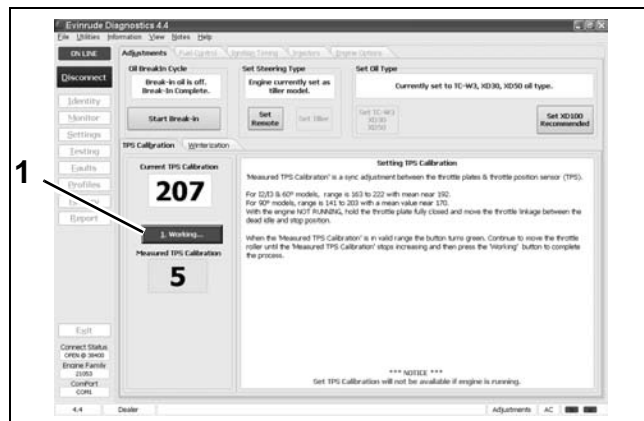

1. TPS Calibration button

008144

Perform TPS Calibration after replacing or adjusting any throttle body or throttle linkage parts.

**4**

# ENGINE MANAGEMENT MODULE (EMM) DIAGNOSTIC SOFTWARE FUNCTIONS

## Fuel Injector Servicing

All *E-TEC* fuel injectors use software programming to compensate for variations in fuel flow. Each injector and its location on the outboard is identified by the *EMM*. DO NOT install an injector without updating the compensation software.

To install a service injector, click the “Replace” button on the *Injector Coefficients* screen and select the file for the replacement injector. Refer to **Vapor Separator and Fuel Injector Service** on p. 132.

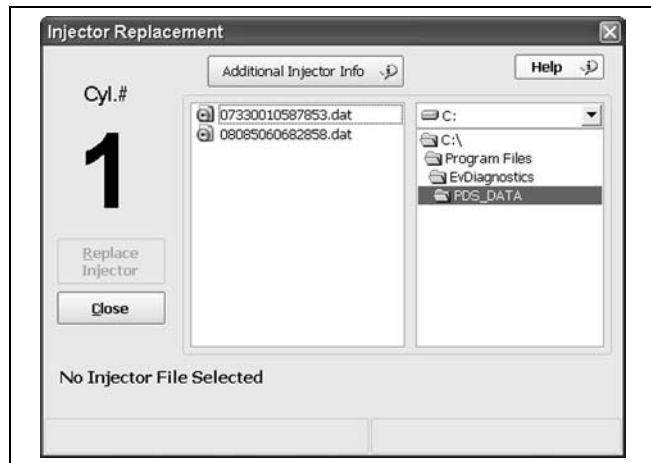

008101

## Reports

Engine reports provide service records and can be used to document the running history of an outboard. Reviewing this information can help identify or resolve some service issues.

Click the print button in a window of the diagnostics software to print engine data, or to export the information to a computer file.

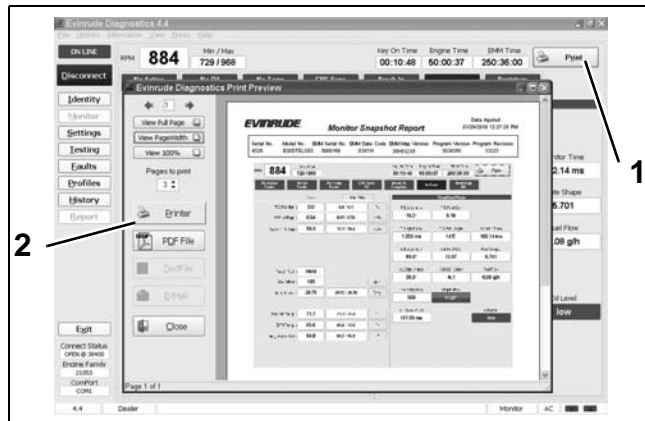

1. Print button
2. Print/Export options

008145

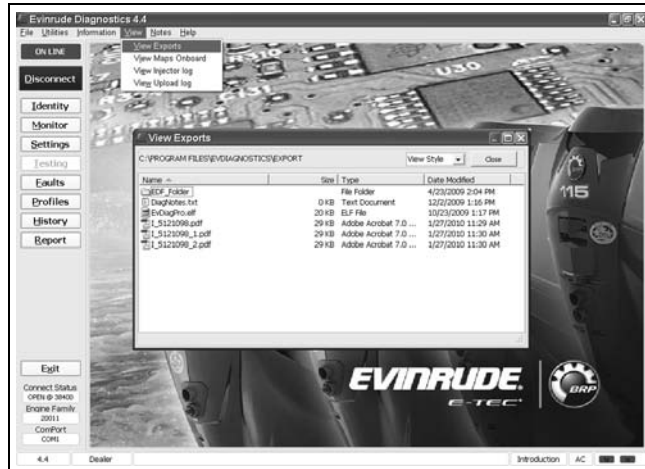

Engine Report data files

008096

## Software Replacement

Engine Management Software programs are loaded into the *EMM* at the factory. Periodically, a new program may be available to enhance the operation of an outboard. Select *Engine Software Update* from the *Utilities* menu and refer to the instructions provided with the program.



008095

**IMPORTANT:** Software replacement requires a Bootstrap Tool, P/N 586551.

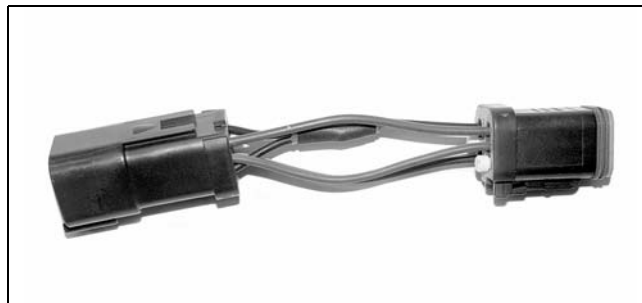

002383

4

## EMM Transfer

*EMM Transfer* is used to save engine history data when the *EMM* must be replaced. Select *EMM Data Transfer* from the *Utilities* menu. Select the Collect *EMM* data to FILE option and follow the instructions provided with the program.

**IMPORTANT:** Whenever the *EMM* is replaced, *EMM* timing must be synchronized to crankshaft position. Refer to **TIMING ADJUSTMENTS** on p. 106.

## **EMM SERVICING**

**IMPORTANT:** If a new *EMM* is being installed, refer to **EMM Transfer** on p. 65.

### **Removal**

Disconnect cooling hoses from *EMM*.

Disconnect J1-A connector.

Remove two *EMM* retaining screws. Remove *EMM*.

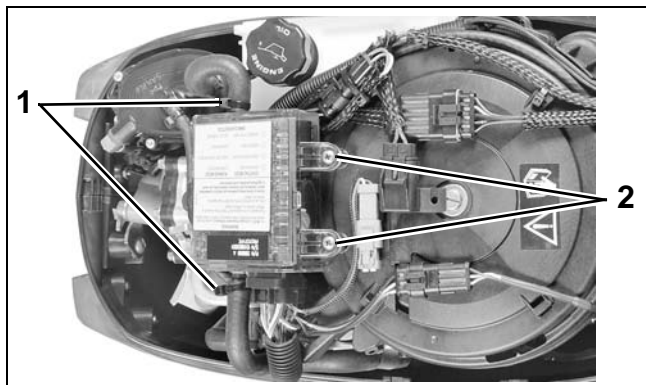

1. Cooling hose connections
2. EMM mounting screws

007396

### **Installation**

Installation is the reverse of removal. Pay close attention when performing the following tasks.

Make sure isolator mount is in place on recoil starter housing. Slide pin at rear *EMM* into position on isolator mount.

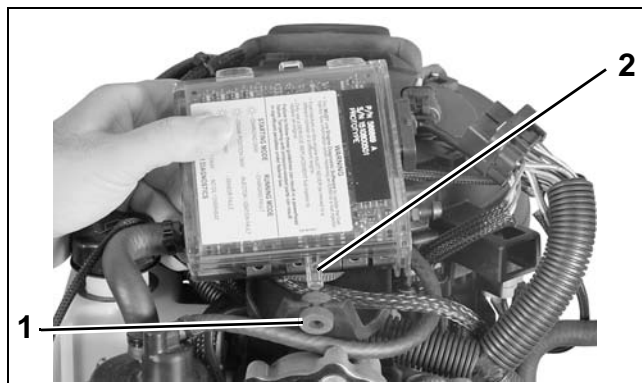

1. Isolator mount
2. Pin

007397

**IMPORTANT:** Turn self-tapping screws counter clock-wise to start the threads and clockwise to tighten. Failure to follow this procedure can damage the threads of the housing.

Tighten screws securely.

Install harness connector and cooling hoses. Secure hoses with tie straps.

# SYSTEM ANALYSIS

## TABLE OF CONTENTS

<b>DIAGNOSTIC PROCEDURES</b> .....	68
<b>VISUAL INSPECTIONS</b> .....	68
<b>OPERATIONAL INSPECTIONS</b> .....	68
<b>TROUBLESHOOTING</b> .....	69
<b>DYNAMIC TESTS</b> .....	70
<b>CYLINDER DROP TESTS</b> .....	70
<b>FUEL CONTROL ADJUSTMENT</b> .....	70
<b>INDUCTIVE AMP METER TEST</b> .....	70
<b>EMM LED INDICATORS</b> .....	71
<b>KEY ON</b> .....	71
<b>STARTING</b> .....	71
<b>RUNNING</b> .....	72
<b>IGNITION OUTPUT TESTS</b> .....	73
<b>REQUIRED IGNITION SYSTEMS</b> .....	73
<b>WIRING INSPECTION</b> .....	73
<b>CRANKSHAFT POSITION SENSOR (CPS) TEST</b> .....	74
<b>SYSTEM VOLTAGE TEST</b> .....	74
<b>STATIC IGNITION TEST</b> .....	75
<b>RUNNING IGNITION TESTS</b> .....	76
<b>IGNITION CONTROL CIRCUIT TESTS</b> .....	77
<b>IGNITION COIL TESTS</b> .....	77
<b>FUEL DELIVERY TESTS</b> .....	78
<b>FUEL PUMP STATIC TEST</b> .....	78
<b>FUEL INJECTOR STATIC TEST</b> .....	78
<b>RUNNING FUEL SYSTEM TESTS</b> .....	79



# DIAGNOSTIC PROCEDURES

## Visual Inspections

Inspect wiring and electrical connections. Disassemble and clean all corroded connections. Replace damaged wiring, connectors, or terminals. Repair any shorted electrical circuits.

- Refer to **ELECTRICAL HARNESS CONNECTIONS** on p. 85.
- Refer to **WIRING DIAGRAM** at the back of this manual.
- Refer to **CONNECTOR SERVICING** on p. 111.

Make sure all ground connections are clean and tight. Refer to **GROUND CIRCUITS** on p. 86.

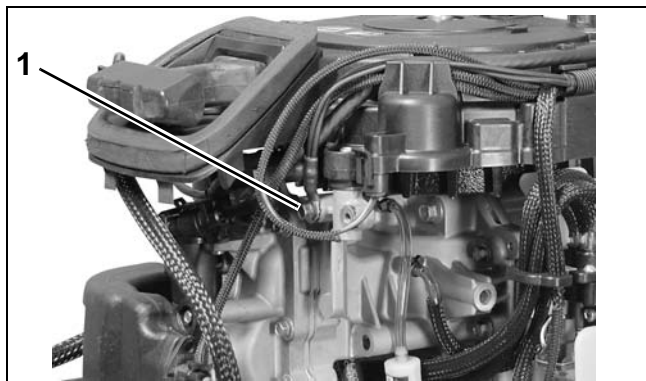

1. Main engine harness ground 007343

Inspect spark plugs for wear, oil fouling, or damage. A rich or lean running condition or evidence of internal engine damage could be identified by the appearance of the spark plugs.

Check the fuse and the emergency stop switch lanyard.

## Operational Inspections

Run the outboard to confirm actual symptoms before performing any unnecessary procedures. Inspection should include the following:

- Make sure the outboard can be cranked easily, with no mechanical binding.
- Check the *EMM* LED Indicators for system status information. Refer to **EMM LED INDICATORS** on p. 71.
- Check the *Evinrude Diagnostics* software *Hard Faults* and *Stored Faults* screens for current service codes. Correct any problems and clear the codes before further troubleshooting. Refer to **Stored Service Codes (Faults)** on p. 60.

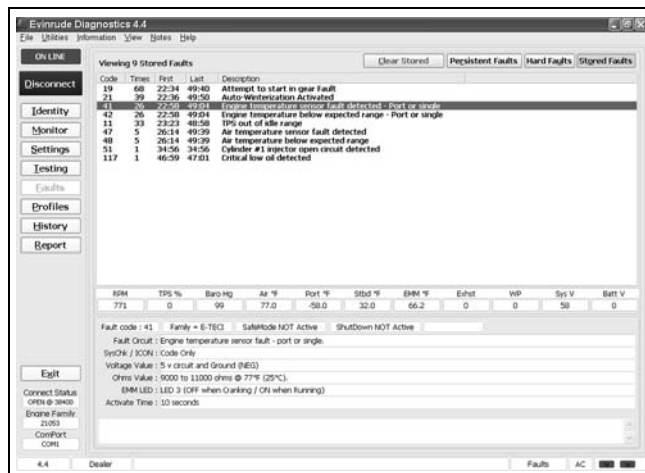

Stored Faults Review Screen 008139

Check the diagnostics software *Profiles*, *History*, and *Persistent Faults* screens for evidence of abnormal operation.

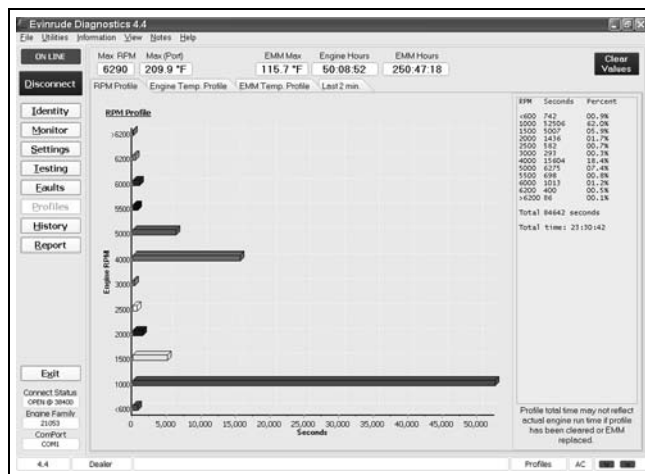

Profiles Screen 008146

## Troubleshooting

### Outboard will not crank, starter does not operate:

- Check condition of battery and cables (main battery switch and cables). Make sure battery cables are not reversed.
- Confirm that switched B+ is present at “A” terminal (yellow/red wire) of starter solenoid with key switch in the START position.
- Check ground at “B” terminal harness connection.
- Refer to **ELECTRIC START TESTS** on p. 96. Repair starter or start circuit as needed.

### Outboard cranks, will not start:

- Check emergency stop switch and lanyard
- Check powerhead mounted neutral switch
- Check the *EMM* LED Indicators for system status information. Refer to **EMM LED INDICATORS** on p. 71.
- Use the *Evinrude Diagnostics* software *Stored Faults* screen to check for current service codes. If there are multiple stored sensor codes, inspect all 5 V sensor circuits for broken or grounded wiring.
- Perform a Static Ignition test using *Evinrude Diagnostics* software and an inductive timing light. Refer to **Static Ignition Test** on p. 75.
- If ignition test indicates steady spark, refer to **FUEL DELIVERY TESTS** on p. 78.

### Outboard runs, low on power, misfires:

- Check the *EMM* LED Indicators for system status information. Refer to **EMM LED INDICATORS** on p. 71.
- Use the *Evinrude Diagnostics* software *Monitor* screen to check system (55 V) and TPS voltages. System voltage should be steady, and TPS voltage should be between 0.2 and 4.85 V.

**IMPORTANT:** Use a digital multimeter to check voltage on external circuits only when necessary. All *EMM* output currents are DC current.

- Use the diagnostics software *Dynamic Tests* to isolate a faulty cylinder. See **DYNAMIC TESTS** on p. 70.
- Use an inductive timing light to check ignition and fuel injector circuits. Refer to **Running Ignition Tests** on p. 76 and **Running Fuel System Tests** on p. 79.
- Use the diagnostics software *Fuel Control Adjustment* test to help identify a cylinder that may be too rich or too lean. Refer to **Fuel Control Adjustment** on p. 70.
- Use an inductive amp meter to monitor injector circuit current. Compare readings of all circuits to identify possible failure.
- Check fuel quality and that fuel is present at injectors.
- Use the diagnostics software *Logging* function to record engine data as a problem is occurring.

The screenshot shows the 'Logging' screen in Evinrude Diagnostics 4.4. It features a table with columns for 'Rec'd', 'Time (ms)', 'RPM', 'TPS (V)', 'Springs', 'Springs', 'Springs', 'Charging Eng (amp/100%)', 'Eng (amp/100%)', 'Water Pressure (psi)', 'Fuel Flow (gph)', and 'Bank Pressure (psi)'. The table contains 36 rows of data. Below the table, there are controls for 'Records: 36', 'Elapsed Sec: 11', and 'Remaining Sec: 88'. The interface also includes navigation buttons like 'Exit', 'Connect Status', and 'Engine Family'.

Logging Screen

008147

- AFTER all the above inspections, if the cause of a running quality problem still cannot be identified, perform a compression test to check for internal powerhead damage.

**IMPORTANT:** Remove a cylinder head or disassemble the engine only as a last resort.



## DYNAMIC TESTS

### Cylinder Drop Tests

Use the *Evinrude Diagnostics* software *Dynamic Tests* to momentarily disable one cylinder while the outboard is running.

- The Dynamic Ignition test disables the ignition and fuel injection circuits to a cylinder.
- The Dynamic Fuel test momentarily disables one fuel injector circuit.

By dropping one cylinder, RPM and running quality changes can be compared for each cylinder.

**IMPORTANT:** Test the outboard at the RPM where the problem is occurring. Use the test procedures to identify inconsistencies in voltages and cylinder performance. Once a circuit has been identified as malfunctioning, inspect all related wiring and connections. Check all voltage inputs and grounds; and perform resistance tests for all circuits before replacing any suspect components.

*Dynamic Tests* can be used with:

- A timing light to determine how other cylinders are affected by one cylinder being “dropped”; or
- A digital multimeter to check voltage changes on electrical circuits.

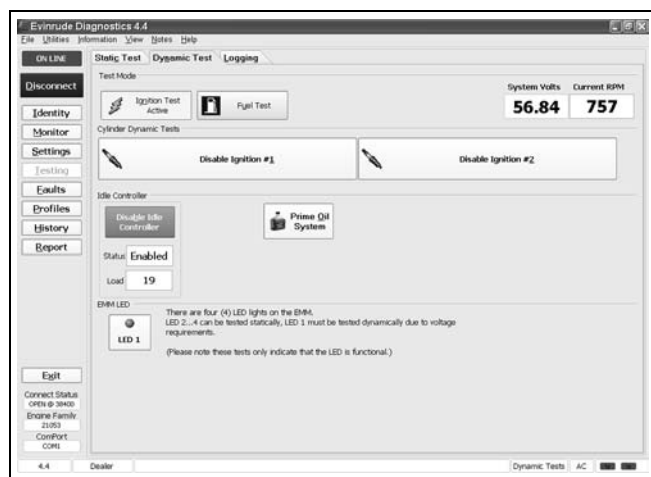

Dynamic Test Screen

008141

**IMPORTANT:** DO NOT misinterpret tests run at IDLE. The idle speed controller in the *EMM* compensates to maintain a constant IDLE speed. The *Dynamic Tests* screen includes a function to temporarily disable the idle controller.

### Fuel Control Adjustment

Use this test is to help identify a cylinder that may be too rich or too lean. This feature should not be used by itself to identify a faulty injector.

*Evinrude Diagnostics* software allows temporary adjustments to the fuel flow characteristics of the injectors. Factory fuel flow settings are restored when power to the *EMM* is returned to OFF.

Test the outboard at the RPM where the problem is occurring.

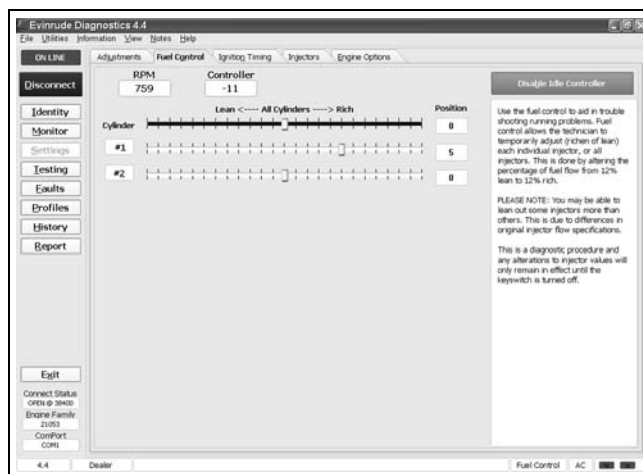

008148

If the outboard run quality improves with a fuel control adjustment, eliminate other possibilities before replacing an injector:

- Refer to **Fuel System Pressure Test** on p. 126.
- Refer to **Running Fuel System Tests** on p. 79.

**IMPORTANT:** DO NOT misinterpret tests run at IDLE. The idle speed controller in the *EMM* compensates to maintain a constant IDLE speed.

### Inductive Amp Meter Test

Use an inductive amp meter to monitor battery charging and current flow. Identifying erratic amperage in a circuit can be used to isolate a problem component.



## EMM LED INDICATORS

The *EMM* LED indicators provide a quick reference to the status of several outboard systems. Checking the LEDs **FIRST** when diagnosing an engine problem can save time.

For detailed code information, refer to the **EMM Service Code Chart** at the back of this manual.

**IMPORTANT:** LED 1 is closest to the center of the *EMM* (closest to *EMM* J1-A connector).

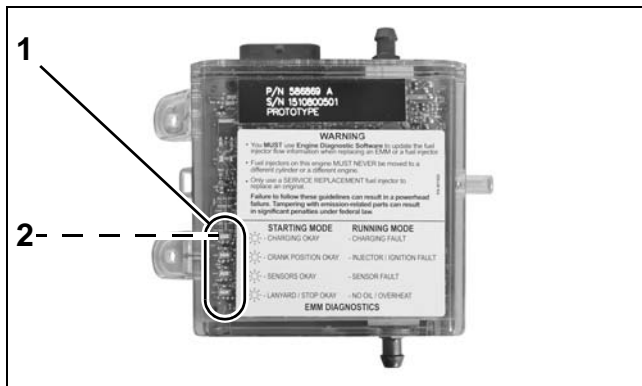

1. LED indicators
2. LED 1

007382

## Key ON

**IMPORTANT:** Diagnostic communications on non-running rope start models requires that power is supplied to the *EMM*. Refer to **Communication** on p. 58.

When the *EMM* is ON (engine not running), the following LEDs should light:

**LED 3** – Sensor Circuits working. FLASHING LIGHT indicates Code 57 – engine will not start.

**LED 4** – Stop Circuit not grounded—okay to start. FLASHING LIGHT indicates severe overheat or no oil – engine in SHUTDOWN mode.

## Starting

Starting mode occurs from the time the flywheel begins to turn until the outboard is running for 2 seconds. During starting, all four LEDs should light and then go off in sequence.

**LED 1** – CHARGING OKAY – Stator signal 30 V or higher.

**LED 2** – CRANK POSITION OKAY – input from CPS, *EMM* powered ON. For NO LIGHT, check for:

- Code 16 – CPS, intermittent loss of sync

**LED 3** – SENSORS OKAY (5 V). For NO LIGHT, check for:

- Code 12 – TPS circuit fault
- Code 13 – TPS below expected range
- Code 14 – TPS above expected range
- Code 19 – In Gear (tiller models)
- Code 23 – *EMM* temp. sensor circuit fault
- Code 24 – *EMM* temp. below expected range
- Code 41 – temp. sensor circuit fault
- Code 42 – temp. below expected range
- Code 47 – AT sensor circuit fault
- Code 48 – AT sensor below expected range
- Code 49 – AT sensor above expected range
- Code 58 – Operating temperature not reached
- Code 78 – Sensor supply voltage fault

For FLASHING LIGHT, check for Code 57.

**LED 4** – LANYARD/STOP OKAY. For NO LIGHT, check for:

- Grounded stop circuit.

For FLASHING LIGHT, check for:

- Code 29 – *EMM* temp. OVER range (flashing)
- Code 31 – Engine temp. OVER range (flashing)
- Code 33 – Engine shutdown, excessive no oil condition

---

## SYSTEM ANALYSIS

### EMM LED INDICATORS

---

#### Running

When the outboard is running, all of the LEDs should be off. If a light is on, check for:

##### LED 1 – CHARGING FAULT:

- Code 17 – system voltage (55 V) below range
- Code 18 – system voltage (55 V) above range
- Code 26 – low battery (12 V) voltage
- Code 27 – high battery (12 V) voltage

##### LED 2 – INJECTOR/IGNITION FAULT:

- Code 51 – cylinder no. 1 injector circuit open
- Code 52 – cylinder no. 2 injector circuit open
- Code 61 – cylinder no. 1 injector circuit short
- Code 62 – cylinder no. 2 injector circuit short
- Code 81 – no. 1 ignition primary circuit open
- Code 82 – no. 2 ignition primary circuit open
- Code 91 – fuel pump open circuit
- Code 94 – fuel pump circuit short
- Code 101 – cylinder no. 1 ignition circuit short
- Code 102 – cylinder no. 2 ignition circuit short

**LED 3** – Sensor circuits (5 V), SENSOR FAULT. For LIGHT ON, check for possible fault codes:

- Code 12 – TPS circuit fault
- Code 13 – TPS below expected range
- Code 14 – TPS above expected range
- Code 16 – CPS, intermittent loss of sync
- Code 23 – *EMM* temp. sensor circuit fault
- Code 24 – *EMM* temp. below expected range
- Code 41 – temp. sensor circuit fault
- Code 42 – temp. below expected range
- Code 47 – AT sensor circuit fault
- Code 48 – AT sensor below expected range
- Code 49 – AT sensor above expected range
- Code 57 – high RPM with low TPS setting
- Code 58 – operating temp. not reached
- Code 78 – Sensor supply voltage fault

**LED 4** – Engine overheat, *EMM* temperature or sensor, oil injection pump or sensor, NO OIL / OVERHEAT. For LIGHT ON, check for possible fault codes:

- Code 25 – *EMM* overheat
- Code 29 – *EMM* overheat, critical (flashing)
- Code 31 – engine overheat, critical (flashing)
- Code 33 – excessive NO OIL faults
- Code 34 – oil injection pump circuit open
- Code 40 – engine temp over range, low speed
- Code 43 – temp. above expected range
- Code 117 – Critical NO OIL detected
- Code 120 – Low Oil Switch circuit OPEN

# IGNITION OUTPUT TESTS

**⚠ DANGER**

The electrical system presents a serious shock hazard. Allow outboard to sit for two minutes after running before handling DO NOT handle primary or secondary ignition components while outboard is running or flywheel is turning.

Use the *Evinrude Diagnostics* software *Stored Faults* screen to check for current service codes before troubleshooting. Correct any problems and clear the codes FIRST.

## Required Ignition Systems

Following is a complete list of circuits required for ignition output:

### Stop Circuit

- Black/yellow wire NOT grounded (emergency stop switch lanyard in place).

### Neutral Switch

- Powerhead mounted neutral switch provides a switched ground circuit to *EMM*. The circuit enables specialized control functions such as neutral start protection and RPM limiting in NEUTRAL.

### Stator Output Voltage

- Provides A/C voltage to *EMM* J1A connector: Outboard cranking, typical range is 20-40 VAC (AC output voltage is related to cranking RPM); Outboard running, approximately 55 VAC.

### *EMM*

- Controls ignition grounds, injector grounds, and engine timing.

### Crankshaft Position Sensor

- Provides *EMM* with input.
- Outboard cranking speed exceeds 300 RPM and a steady CPS signal is generated.

### Alternator Output/System Voltage

- System voltage from *EMM* (white/red) provides 55 VDC to the high pressure fuel pump, the oil injection pump, the fuel injectors, and the ignition coils.

### Ignition Coil

- Primary circuits are powered by system (55 V) voltage
- *EMM* provides control signal to ignition coil
- Output from ignition coil secondary winding and high tension spark plug wire.

## Wiring Inspection

Visually inspect all wiring, connections, and grounds.

Use a digital ohmmeter to test resistance on all ground circuits and connections. Ohmmeter readings should be approximately 0.0 W.

Check that all engine wire harness grounds have continuity to the cylinder/crankcase.

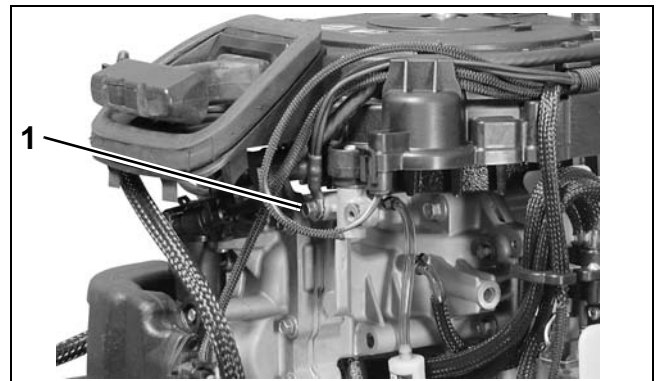

1. Main engine harness ground

007343

Clean or repair all ground circuits, wiring, and connections as needed.

## SYSTEM ANALYSIS

### IGNITION OUTPUT TESTS

## Crankshaft Position Sensor (CPS) Test

When the CPS is working properly, *EMM* LED 2 turns on while the outboard is being started.

Use the *Evinrude Diagnostics* software CPS Sync and engine RPM displays to confirm a valid CPS signal while the outboard is cranking or running. An RPM display higher than zero indicates a CPS signal to the *EMM*.



Engine RPM and CPS Sync displays

008137

If the *Monitor* screen says “Check CPS Sync,” refer to **Crankshaft Position Sensor (CPS) Test** on p. 87.

## System Voltage Test

The ignition system is powered by the 55 V system.

Use the *Evinrude Diagnostics* software *Monitor* screen to check system voltage.



Monitor Screen, System voltage

008137

### Results:

- *EMM* ON (not running) - approximately 1 V less than battery voltage, system voltage is GOOD.
- *EMM* ON (not running) - no voltage, check 12 V power to *EMM*. Repair connection or wiring.
- RUNNING - 55 V  $\pm$  2, system voltage is GOOD.
- RUNNING - less than 55 V  $\pm$  2, check stator output to *EMM*. Repair connection or wiring. Possible faulty stator or *EMM*. Refer to **STATOR TESTS** on p. 89.

**IMPORTANT:** The *EMM* must be ON for voltage to be present on the system voltage (55 V) circuit. Power is normally supplied to the *EMM* when the key switch is turned ON. The *EMM* is also turned ON when it begins to receive AC voltage from the stator while the outboard is being cranked. On a non-running rope start engine, power is supplied to the *EMM* by Diagnostic Power Supply Tool, P/N 587005.

## Static Ignition Test

Perform the static ignition test using *Evinrude Diagnostics* software and an inductive timing light.

**IMPORTANT:** Do NOT perform static tests using Diagnostic Power Supply Tool, P/N 587005, with internal 9 volt batteries only. This will produce false results. Refer to **Communication** on p. 58.

**IMPORTANT:** DO NOT use a spark checker tool. Radio Frequency Interference (RFI) generated by the arcing current can cause erratic *EMM* operation.

The outboard must NOT be running and the emergency stop switch lanyard must be installed.

**IMPORTANT:** This test is operating the ignition coil with 12 V battery power on the system voltage (55 V) circuit. An inductive probe with low sensitivity may not be able to detect the signal.

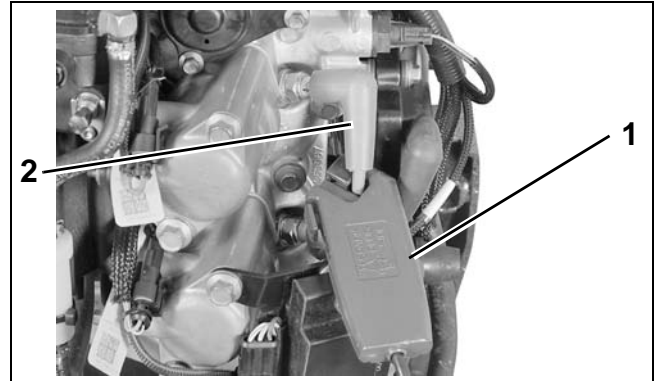

1. Timing light pick-up
2. Spark plug lead

007398

5

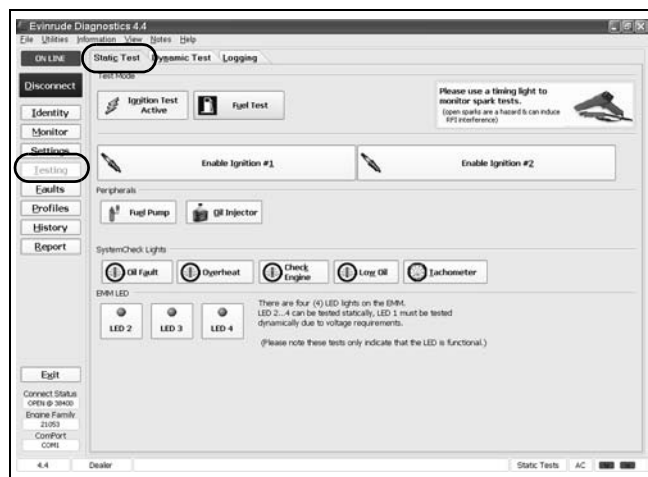

Static Tests Screen

008140

Connect timing light pickup to the secondary circuit (spark plug lead) of the cylinder being tested. Activate test and observe timing light strobe for consistent flash.

### Results:

No spark on one or more cylinders:

- Inspect or replace spark plugs
- Refer to **Ignition Control Circuit Tests** on p. 77
- Refer to **Ignition Coil Tests** on p. 77

Steady spark on all cylinders:

- Refer to **Running Ignition Tests** on p. 76 and **DYNAMIC TESTS** on p. 70.

---

## SYSTEM ANALYSIS

### IGNITION OUTPUT TESTS

---

#### Running Ignition Tests

Use *Evinrude Diagnostics* Software to monitor system voltage (55 V).

- Voltage readings at a specific speed (RPM) should be steady.
- Refer to **System Voltage Test** on p. 74.

Use an inductive timing light to monitor the spark signal through each of the secondary circuit (spark plug lead) wires.

Start outboard and observe timing light strobe. Look for a consistent flash and only one flash per revolution. The strobe of the timing light should be the same for each cylinder.

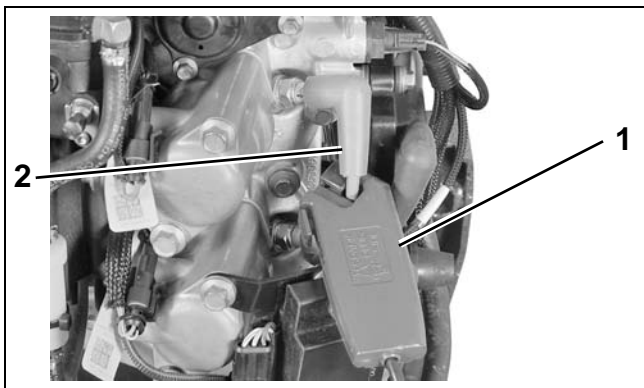

1. Timing light pick-up
2. Spark plug lead

007398

#### Results:

Steady voltage and strobe, engine misfires:

- Inspect or replace spark plugs
- Refer to **FUEL DELIVERY TESTS** on p. 78
- Inspect for internal engine damage.

Steady voltage, erratic strobe, engine misfires:

- Inspect or replace spark plugs
- Check CPS air gap and resistance.
- Refer to **Ignition Control Circuit Tests** on p. 77
- Refer to **Ignition Coil Tests** on p. 77.

Voltages fluctuate, engine misfires:

- Inspect battery and connections
- Test capacitor and all ground connections.
- Refer to **System Voltage Test** on p. 74
- Refer to **Ignition Control Circuit Tests** on p. 77
- Refer to **Ignition Coil Tests** on p. 77.

**IMPORTANT:** If a running problem occurs at about 1200 RPM, the outboard may be in *S.A.F.E.* Refer to **S.A.F.E. WARNING SYSTEM** on p. 57.

## Ignition Control Circuit Tests

Use a digital multimeter to test the following:

- System voltage supply to ignition coil.
- Ignition control signal from *EMM*.
- Engine harness resistance.

Disconnect ignition coil connector.

### Supply voltage test:

Use an appropriate adapter to connect the red meter lead to pin 3 (white/red) of the engine harness connector and the black lead to ground. With *EMM* ON, voltage should be approximately 1 V less than battery voltage.

### Control signal test:

Set meter to the Hz scale to check ignition control signal.

Use an appropriate adapter to connect the red meter lead to pin 2 (orange) of the engine harness connector and the black lead to ground. Activate diagnostics software *Static Ignition* test and observe meter for consistent reading (approximately 2 Hz).

If control signal is present, connect black meter lead to pin 1 and repeat test to confirm harness ground.

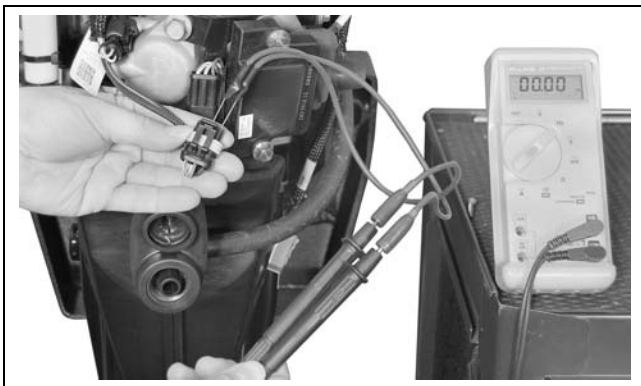

007399

### Harness resistance test:

If control signal is NOT present, calibrate multimeter to low ohms scale. Use appropriate adapters on meter leads to avoid damaging harness connectors.

With *EMM* OFF, remove the *EMM* J1-A connector and test the continuity of each ignition control circuit (orange). Check resistance between J1-A connector and ignition coil connector. Refer to engine wiring diagram.

If circuits test good, replace *EMM*.

## Ignition Coil Tests

There are no simple ignition coil tests available. Before replacing an ignition coil, be sure:

- 55 V is supplied to the white/red wire of the ignition coil connector
- A control signal is present on the orange wire of the ignition coil connector. Refer to **Ignition Control Circuit Tests** on p. 77.
- The black wire of the ignition coil connector provides continuity to ground.
- The secondary spark plug lead provides continuity.

If all of the above tests are good, and a cylinder does not have spark, replace the ignition coil with a known good coil.

# FUEL DELIVERY TESTS

## **⚠ WARNING**

**Protect against hazardous fuel spray. Before starting any fuel system service, carefully relieve fuel system pressure.**

Refer to **Relieving Fuel System Pressure** on p. 130.

Check the *Evinrude Diagnostics* software *Stored Faults* screen for current service codes before troubleshooting. Correct any problems and clear the codes FIRST.

Inspect all fuel hoses, filters, and connections. Check quality of fuel supply.

## Fuel Pump Static Test

Use the *Evinrude Diagnostics* software Fuel Pump test to activate the electric fuel pump. If the pump runs, the *EMM* and fuel pump circuit are not at fault.

**IMPORTANT:** Do NOT perform static tests using Diagnostic Power Supply Tool, P/N 587005, with internal 9 volt batteries only. This will produce false results. Refer to **Communication** on p. 58.

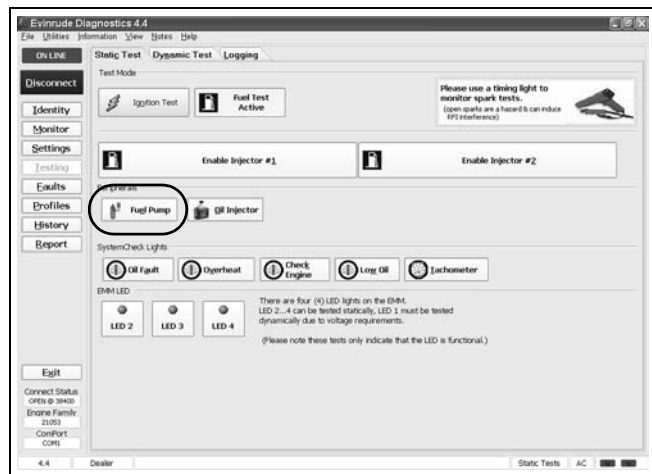

Static Tests Screen

008149

If the pump does not run:

- Check voltage at pin 1 of fuel pump connector. Voltage should be slightly less than 12 V with KEY ON, or when fuel pump test is activated.

Voltage should be 55 V when the outboard is cranking or running.

- The *EMM* controls the fuel pump ground (brown wire). Use an ohmmeter to check continuity between pin 2 of fuel pump connector and ground. Use the fuel pump static test to activate the control function of the *EMM*. Resistance should drop as *EMM* connects the control circuit to ground.
- Refer to **Circulation Pump Resistance Test** on p. 128.

If the pump runs:

- Refer to **Fuel System Pressure Test** on p. 126.
- Refer to **Running Fuel System Tests** on p. 79.

## Fuel Injector Static Test

Use the *Evinrude Diagnostics* software Fuel Injector Static Test to activate each fuel injector. Listen for an audible click from each injector when it is actuated. If the injector activates, the *EMM* and injector circuits are not at fault.

**IMPORTANT:** Do NOT perform static tests using Diagnostic Power Supply Tool, P/N 587005, with internal 9 volt batteries only. This will produce false results. Refer to **Communication** on p. 58.

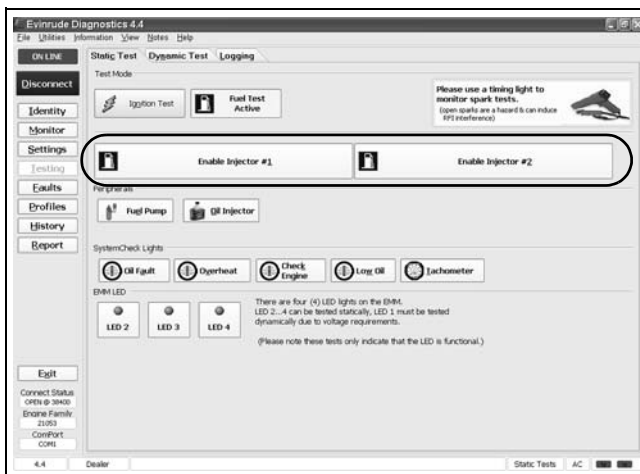

Static Tests Screen

008149

**IMPORTANT:** This test is operating the injectors with 12 V battery power on the system voltage (55 V) circuit. Battery must be fully charged and connections must be clean and tight. Injector activation should be carefully confirmed.



**Results:**

No injectors actuate:

- Use the *Monitor* screen of the diagnostics software to make sure voltage is present on the system voltage circuit.
- Refer to **Running Fuel System Tests** on p. 79.

Some injectors actuate; some do not:

- For non-working injectors, test the resistance of injector circuit between the injector connector and injector control wire at the *EMM*.
- See **Fuel Injector Resistance Test** on p. 127.

All injectors actuate:

- Refer to **Running Fuel System Tests** on p. 79.

## Running Fuel System Tests

Run or crank the outboard.

Use the *Evinrude Diagnostics* software *Monitor* screen to check system voltage. If voltage is low, or drops as RPM increases, refer to **Stator Voltage Output Test** on p. 89.

Use an inductive timing light to monitor the injector control wire (connector pin 2) for each injector. Make sure the pickup is attached to only one wire. Flashes on the timing light indicate current in the circuit is being switched by the *EMM*. The *Dynamic Tests* screen allows the control signal to be turned off to a particular injector.

**IMPORTANT:** Some timing lights may not flash consistently at cranking speeds. Always check the orientation of the timing light pickup and the operation of the timing light.

**Results:**

No light activation on any injector wires (outboard cranks and starter turns flywheel):

- Check stator input to *EMM*, CPS operation, and all grounds and wiring connections.
- Eliminate all other possibilities to isolate a faulty *EMM*.

Irregular or no light activation on some injector wires:

- Test the resistance of individual injector circuits between the injector connector and injector control wire at the *EMM*.
- Check battery cable connections.
- Make sure all grounds are clean and tight.
- See **Fuel Injector Resistance Test** on p. 127.

Steady light activation on all injector wires and consistent voltage readings, *EMM* injector control function is good:

- Use the diagnostics software *Dynamic Fuel Test* to isolate a faulty cylinder. See **DYNAMIC TESTS** on p. 70.



Dynamic Tests Screen

008150

- Refer to **Fuel Injector Pressure Test** on p. 127.
- Refer to **Fuel System Pressure Test** on p. 126.



# ELECTRICAL AND IGNITION

## TABLE OF CONTENTS

SERVICE CHART .....	82
IGNITION SYSTEM CIRCUIT DIAGRAM .....	84
ELECTRICAL HARNESS CONNECTIONS .....	85
GROUND CIRCUITS .....	86
FUSE .....	86
SENSOR TESTS .....	87
CRANKSHAFT POSITION SENSOR (CPS) TEST .....	87
THROTTLE POSITION SENSOR (TPS) TEST .....	87
ENGINE TEMPERATURE SENSOR TEST .....	88
AIR TEMPERATURE SENSOR (AT) TEST .....	88
STATOR TESTS .....	89
CHARGING SYSTEM TESTS .....	91
ELECTRIC START CIRCUIT .....	94
ELECTRIC START TESTS .....	96
REMOTE CONTROL SWITCH TESTS .....	98
KEY SWITCH TEST .....	98
NEUTRAL START CIRCUIT TEST .....	98
NEUTRAL START SWITCH TEST .....	99
EMERGENCY STOP SWITCH TEST .....	99
TILT/TRIM RELAY TEST .....	100
SYSTEMCHECK CIRCUIT TESTS .....	101
TACHOMETER CIRCUIT TESTS .....	103
FLYWHEEL AND STATOR SERVICING .....	103
FLYWHEEL REMOVAL .....	103
STATOR SERVICE .....	104
FLYWHEEL INSTALLATION .....	104
IGNITION COIL SERVICING .....	105
IGNITION COIL REMOVAL .....	105
IGNITION COIL INSTALLATION .....	105
TIMING ADJUSTMENTS .....	106
TIMING POINTER .....	106
TIMING VERIFICATION .....	106
TPS CALIBRATION .....	106
ELECTRIC STARTER SERVICING .....	107
STARTER REMOVAL .....	107
STARTER DISASSEMBLY .....	107
STARTER CLEANING AND INSPECTION .....	108
STARTER ASSEMBLY .....	109
STARTER INSTALLATION .....	111
CONNECTOR SERVICING .....	111

**ELECTRICAL AND IGNITION  
SERVICE CHART**

**SERVICE CHART**

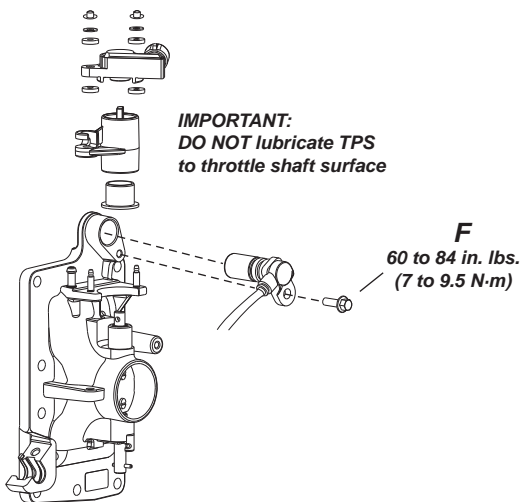
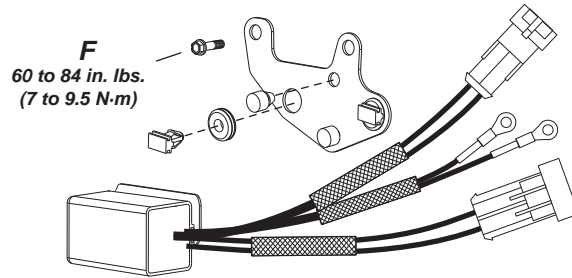
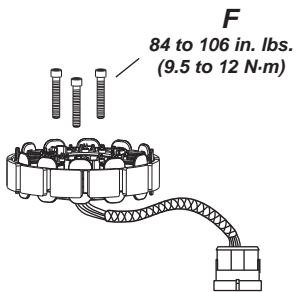
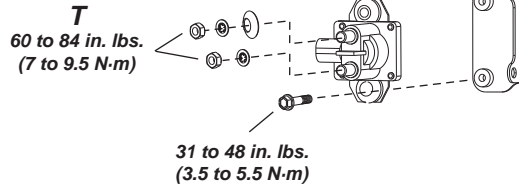
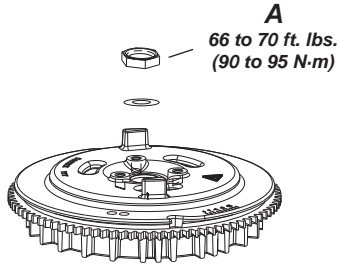

<b>A</b>	Triple-Guard Grease
<b>B</b>	Gasket Sealing Compound
<b>C</b>	Adhesive 847
<b>D</b>	Moly Lube
<b>E</b>	Red Ultra Lock
<b>F</b>	Blue Nut Lock
<b>N</b>	Starter Bendix Lube
<b>T</b>	Liquid Neoprene

007340

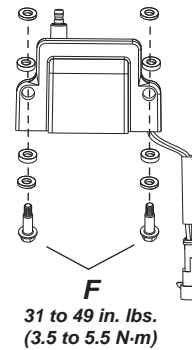
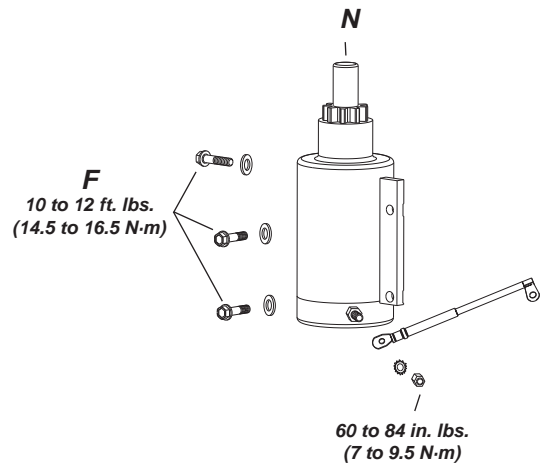
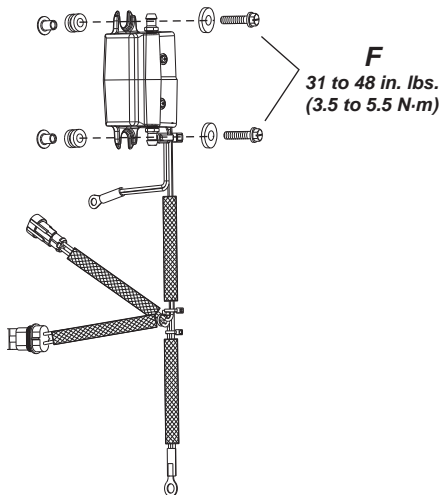
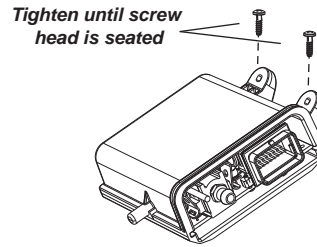
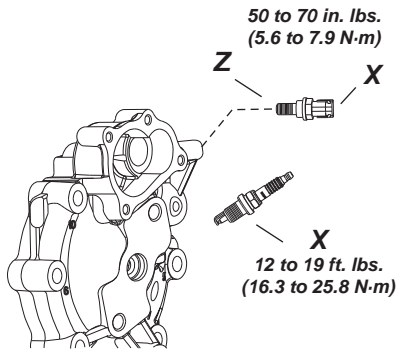

- A** Triple-Guard Grease
- B** Gasket Sealing Compound
- C** Adhesive 847
- D** Moly Lube
- E** Red Ultra Lock
- F** Blue Nut Lock
- T** Liquid Neoprene
- X** See Service Manual Text
- Z** Thermal Joint Compound

007341

# IGNITION SYSTEM CIRCUIT DIAGRAM

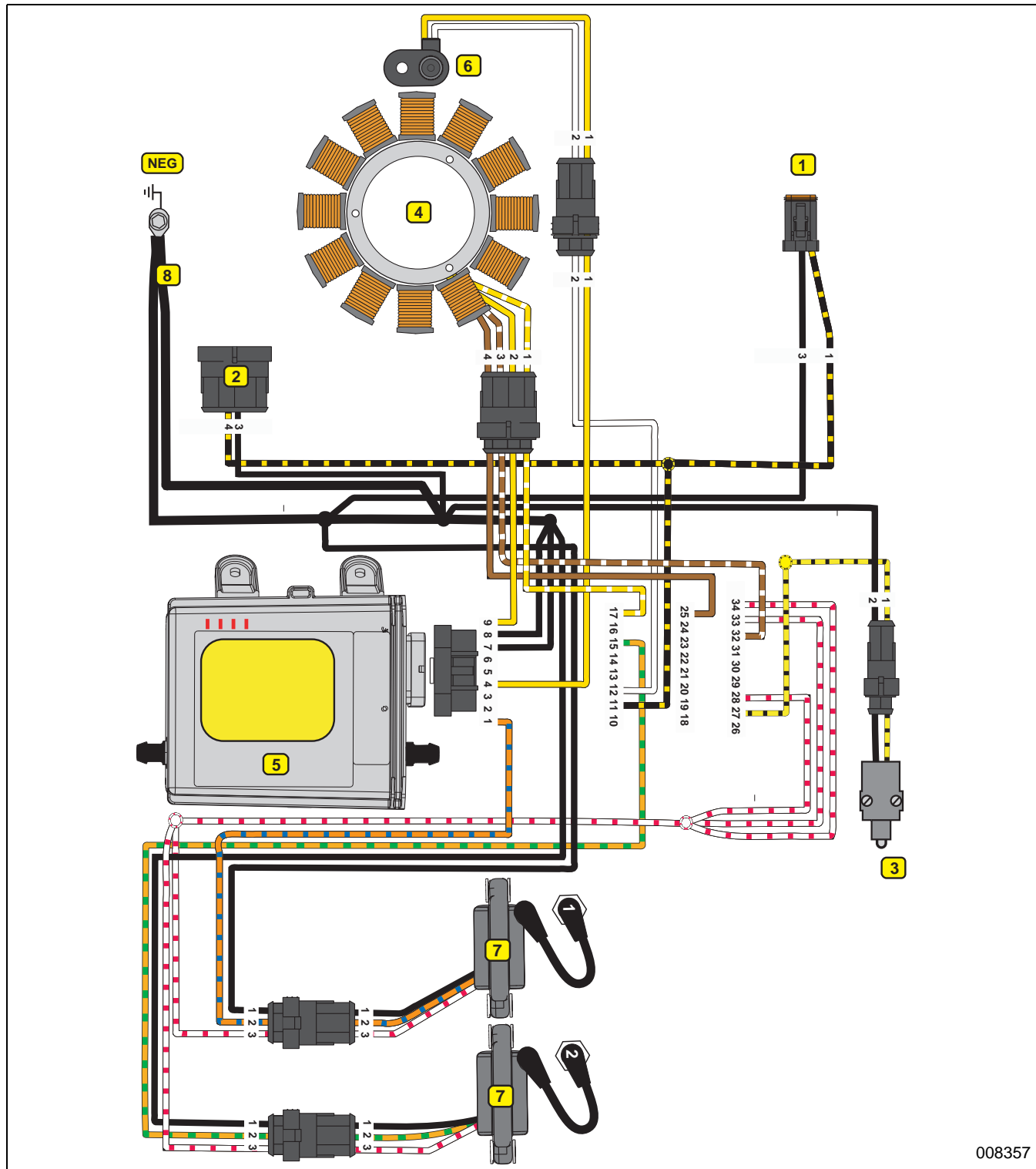

008357

- |                              |                               |                        |
|------------------------------|-------------------------------|------------------------|
| 1. Key switch (stop circuit) | 4. Stator                     | 7. Ignition coil       |
| 2. Tiller handle stop switch | 5. <i>EMM</i>                 | 8. Main harness ground |
| 3. Powerhead neutral switch  | 6. Crankshaft position sensor |                        |

# ELECTRICAL HARNESS CONNECTIONS

Inspect wiring and electrical connections. Disassemble and clean all corroded connections. Replace damaged wiring, connectors, or terminals. Repair any shorted electrical circuits. Refer to wiring diagrams and reference charts for specific wiring details.

Refer to **CONNECTOR SERVICING** on p. 111.

## Engine Harness to Stator Connector

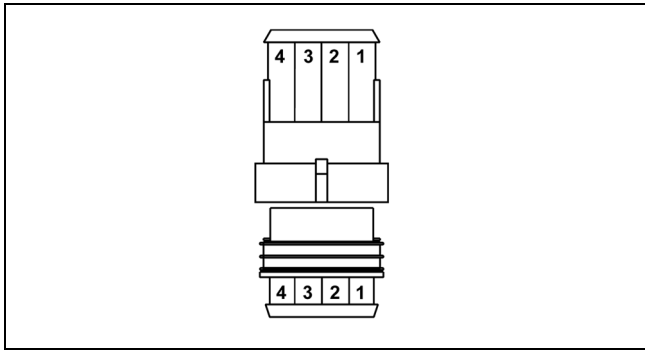

007444

Pin No.	Description of Circuit	Wire Color
1	Stator winding (yellow)	Yellow/White
2	Stator winding (yellow)	Yellow
3	Stator winding (brown)	Brown/White
4	Stator winding (brown)	Brown

## EMM J1-A Connector

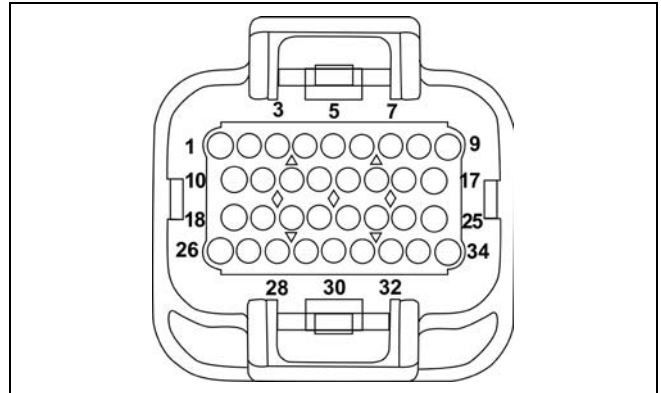

001875

Pin No.	Description of Circuit	Wire Color
1	Ignition, cylinder 1	Orange/Blue
2	Oil solenoid	Blue
3	Switched B+ to <i>EMM</i>	Purple
4	Crankshaft position sensor (CPS)	Yellow
5	Injector, cylinder 2	Green
6	Injector, cylinder 1	Blue
7	System Ground	Black
8	System Ground	Black
9	Stator winding, 1S	Yellow
10	CANbus, NET-H	White
11	Stop circuit	Blk/Yellow
12	Ground, CPS (digital)	White
13	Touch Troll	Pink
14	Bootstrap connector (programming)	Blk/Orange
15	Ignition, cylinder 2	Orange/Green
16	LOW OIL signal, <i>SystemCheck</i>	Tan/Black
17	Stator winding, 1F	Yellow/White
18	CANbus, NET-L	Blue
19	Air temperature sensor	Pink/Blue
20	Engine temperature sensor	Pink/Black
21	TPS	Green
22	Diagnostic connector	Red
23	Diagnostic connector	White
24	Tachometer	Gray
25	Stator winding, 2S	Brown
26	Fuel pump control	Brown
27	Neutral switch	Yellow/Black
28	+55 V, out	White/Red
29	System ground	Black
30	+5 V, out	Red
31	Low oil switch	Tan/Black
32	Stator winding, 2F	Brown/White
33	+55 V, out	White/Red
34	+55 V, out	White/Red

## GROUND CIRCUITS

All ground circuits are essential to reliable out-board performance. Make sure all ground connections are clean and tight. Refer to wiring diagrams for specific wiring details.

### **EMM Ground Tests**

Disconnect the battery cables at the battery.

Use an ohmmeter to check continuity of ground circuits. Calibrate the ohmmeter on the high ohms scale. Resistance readings for all ground circuits should be 0 W.

- System/power supply grounds: Check continuity between terminal pins 7, and 8 of *EMM* connector and the main harness ground.
- Injector circuit grounds: Check continuity between terminal pins 7 and 8 of the *EMM* connector and the main harness ground.
- Sensor circuit grounds: Check continuity between terminal pin 29 of the *EMM* connector and the appropriate sensor ground connections. Refer to wiring diagrams.

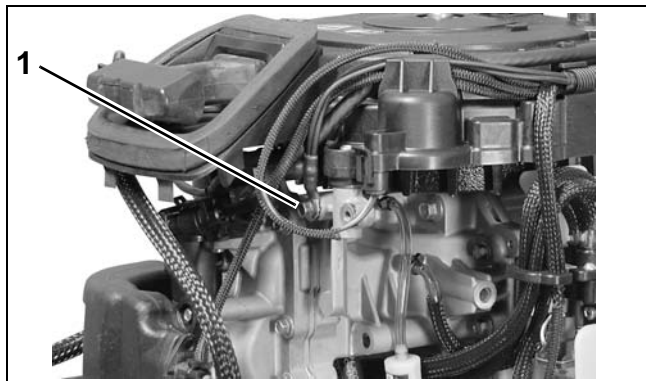

1. Main harness ground

007343

### **Additional Ground Tests**

Check connections and continuity at the following locations:

- Starter solenoid terminal B and main harness ground.
- Trim and Tilt module ground at main harness ground.

## FUSE

The engine harness 12 V (B+) circuit is protected by one automotive style 10 amp minifuse.

The fuse is located on the top of the recoil starter housing.

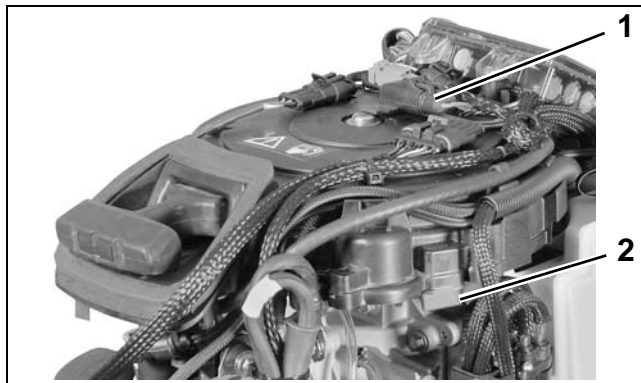

1. Fuse  
2. Spare fuse

007344

**IMPORTANT:** Repeat failures of fuse could be the result of faulty connections or accessories. The 12 V accessory circuit (purple wire from terminal "A" of key switch) is often used to power accessories.



## SENSOR TESTS

All sensor circuits are dependent on wiring and connections, *EMM* supplied current (5 V), and sensor resistance. The supplied current flows through the wiring circuit and sensor before returning to the *EMM*.

**IMPORTANT:** Use *Evinrude Diagnostics* software to monitor sensor circuit voltages or values.

### Crankshaft Position Sensor (CPS) Test

Use the *Evinrude Diagnostics* software CPS Sync and engine RPM displays to confirm a valid CPS signal while the outboard is cranking or running. An RPM display higher than zero indicates a CPS signal to the *EMM*.

Remove the electrical connector from its retainer on the recoil starter housing. Disconnect the crankshaft position sensor.

Use a digital multimeter to measure sensor resistance between the yellow and white wires. The complete circuit can be tested by measuring between pins 4 and 12 of the *EMM* connector.

Sensor Resistance
560 $\Omega$ $\pm$ 10% @ 77°F (25°C)

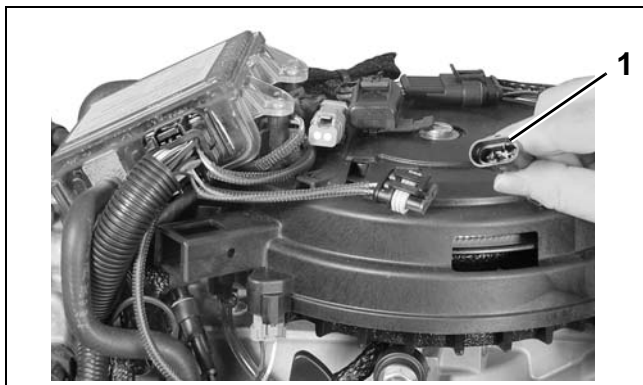

1. CPS Connector

007345

The CPS is mounted to throttle body housing and requires no adjustment. Air gap or clearance to flywheel is fixed at approximately 0.054 in.

(1.37 mm). The acceptable clearance is 0.018 to 0.091 in. (0.45 to 2.38 mm).

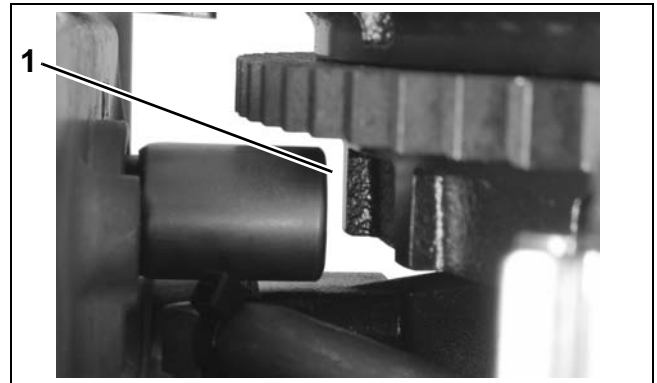

1. CPS gap

006527

### Throttle Position Sensor (TPS) Test

Use *Evinrude Diagnostics* software to monitor TPS voltage while the outboard is running. Voltage should change evenly as sensor lever is moved.

Remove the electrical connector from the throttle position sensor.

Use a digital multimeter to measure sensor resistance.

Sensor Resistance between "A" and "B"
3000 to 7000 $\Omega$ @ 77°F (25°C)

Sensor Resistance between "A" and "C"
4000 to 8000 $\Omega$ @ 77°F (25°C)

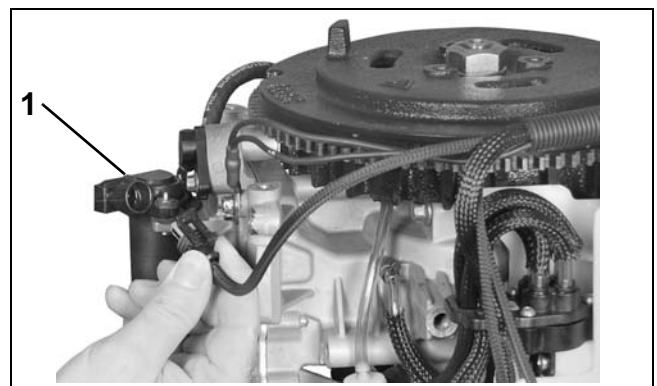

1. TPS

007346

## ELECTRICAL AND IGNITION

### SENSOR TESTS

Connect red meter lead to terminal “A” and black meter lead to terminal “C.” Rotate the sensor lever through its range of travel. Resistance reading must change evenly as the sensor lever is moved.

Connect red meter lead on terminal “B” and black meter lead to terminal “C.” Rotate the sensor lever. Resistance reading must change evenly as the sensor lever is moved.

### Engine Temperature Sensor Test

Remove the electrical connector from the engine temperature sensor.

Use a digital multimeter to measure sensor resistance.

Engine Temperature Sensor Resistance
680 $\Omega$ $\pm$ 5% @ 212°F (100°C)
10000 $\Omega$ $\pm$ 1% @ 77°F (25°C)
32654 $\Omega$ $\pm$ 2.5% @ 32°F (0°C)

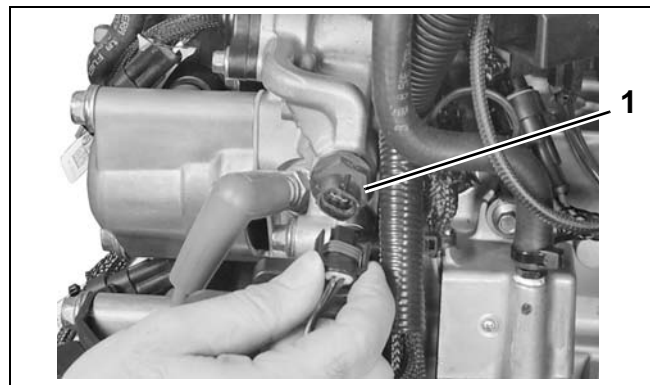

1. Engine temperature sensor

007347

### Air Temperature Sensor (AT) Test

Remove the electrical connector from the air temperature sensor.

Use a digital multimeter to measure sensor resistance.

AT Sensor Resistance
680 $\Omega$ $\pm$ 5.25% @ 212°F (100°C)
10000 $\Omega$ $\pm$ 1.5% @ 77°F (25°C)
32654 $\Omega$ $\pm$ 3.0% @ 32°F (0°C)

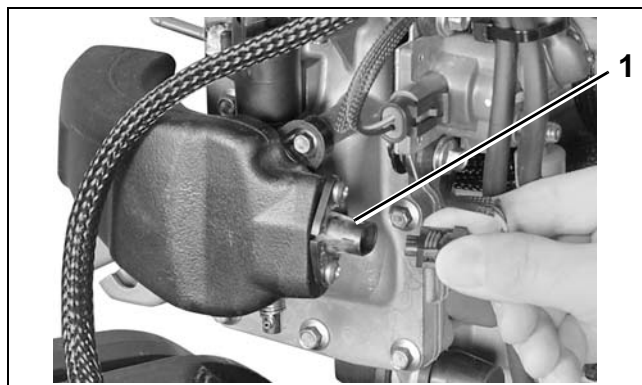

1. AT sensor

007348

## STATOR TESTS

The stator consists of 2 windings (6 poles each) on a 5 inch diameter core and generates an output voltage of 55 VAC (700 watts maximum). This voltage is converted by the Battery Charge Module to provide 12 VDC for battery charging (approximately 8 A at 500 RPM and 15 A from 3000 RPM to WOT) and 55 VDC for fuel injector, and fuel and oil pump operation.

### Stator Resistance Tests

Use a digital multimeter to check resistance of stator windings.

Disconnect stator (4-pin) connector from the engine harness (4-pin) connector.

#### Stator Winding Resistance Specification

Yellow & Yellow / white  
 $1.0 \pm 0.020 \Omega @ 73^\circ\text{F} (23^\circ\text{C})$

Brown & Brown / white  
 $1.0 \pm 0.020 \Omega @ 73^\circ\text{F} (23^\circ\text{C})$

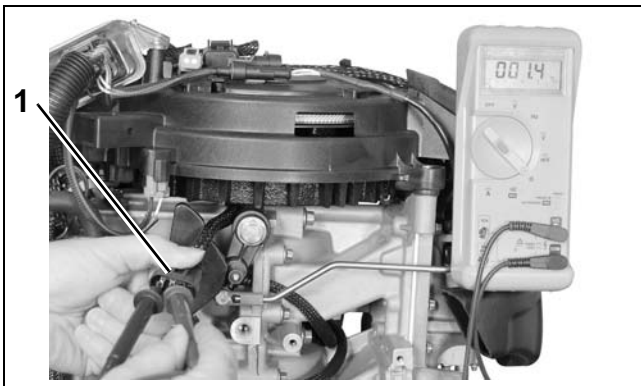

1. Stator connector

007349

Connect meter leads to the following pins:

- Yellow/white and yellow (pins 1 and 2)
- Brown/white and brown (pins 3 and 4)

**IMPORTANT:** A reading of less than 2 ohms is acceptable. Make sure meter is calibrated to read 1 ohm or less.

To check for a grounded winding, connect one meter lead to ground and alternately connect the other meter lead to each stator wire. Meter should read no continuity. If meter reads continuity, replace stator.

### Stator Voltage Output Test

#### ELECTRIC START MODELS

Use a digital multimeter to check stator output voltage. Set meter to read 110 VAC output.

#### ⚠ WARNING

To prevent accidental starting of outboard, disconnect crankshaft position sensor (CPS).

Disconnect CPS.

Disconnect stator (4-pin) connector from the engine harness (4-pin) connector.

Connect Stator Test Adaptor tool, P/N 354719, to stator connector.

Connect meter leads to terminals of adaptor tool.

With a fully charged battery, crank outboard (300 RPM minimum) and observe meter reading:

- 55 VAC above 500 RPM

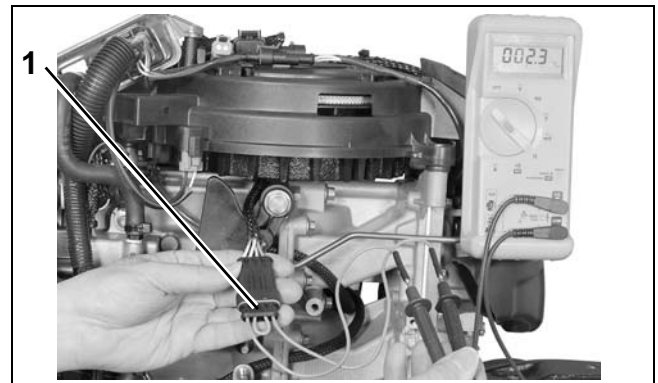

1. Stator Test Adaptor

007350

## ELECTRICAL AND IGNITION

### STATOR TESTS

#### **ROPE START MODELS**

Use a Peak Reading Voltmeter, P/N 507972, to check stator output voltage. Set meter to the 50 VAC scale.

#### **⚠ WARNING**

**To prevent accidental starting of outboard, disconnect crankshaft position sensor (CPS).**

Disconnect CPS. Remove spark plugs. Make sure outboard is in NEUTRAL. Refer to **SPARK PLUGS** on p. 36.

Disconnect stator (6-pin) connector from the engine harness (6-pin) connector.

Connect Stator Test Adaptor tool, P/N 354719, to stator connector.

Connect meter leads to terminals of adaptor tool.

Rotate the flywheel with the starter rope, using a long, steady pull.

Stator output voltage should be approximately 30 VAC.

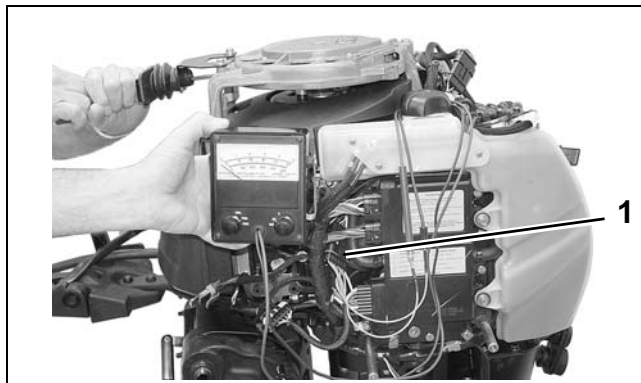

1. Stator Test Adaptor

006750

**IMPORTANT:** Index all spark plugs. Refer to Spark Plug **Indexing** on p. 36.

# CHARGING SYSTEM TESTS

## Charging System Circuit Diagram

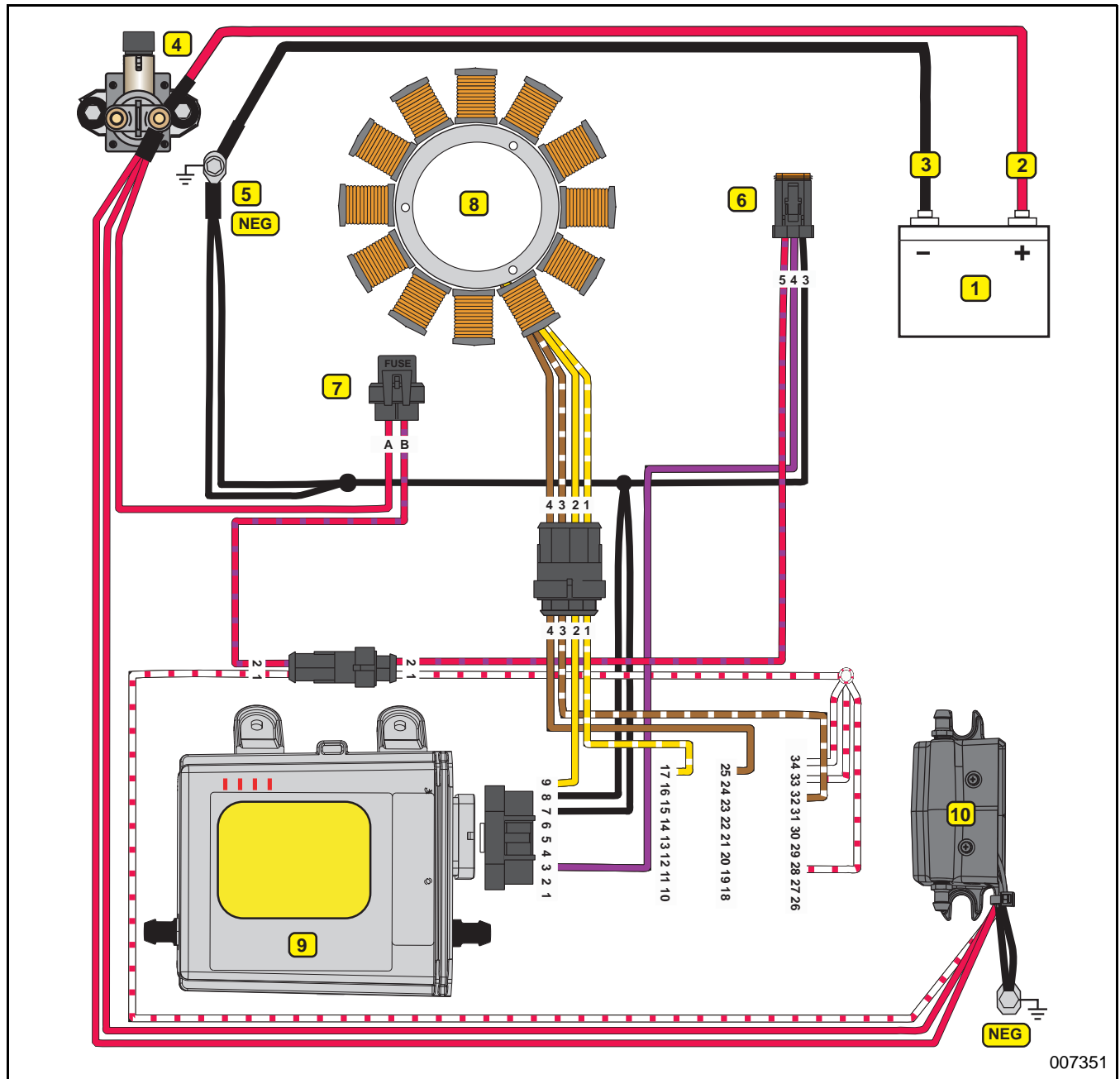

1. Marine battery
2. RED wire (POS)
3. BLACK wire (NEG)
4. Starter solenoid
5. Main harness ground

6. Key switch connector
7. Fuse (10 amp)
8. Stator
9. EMM
10. Battery charge module

## ELECTRICAL AND IGNITION CHARGING SYSTEM TESTS

### 12 V Charging Circuit

To test the operation of the regulator in the battery charge module, you must be able to run the out-board continuously at approximately 5000 RPM, such as in a test tank or on a marine dynamometer.

The test consists of monitoring the system's response to a partially discharged battery. Use a variable load tester to discharge the battery.

Disconnect the battery cables at the battery.

Use an inductive amp meter or connect a 0 to 50 A ammeter in series between the red wire of engine wire harness (alternator output from Battery Charge Module) and the positive (B+) battery cable terminal of starter solenoid.

*Fluke*<sup>†</sup> model 334 or 336, *Snap-On*<sup>†</sup> model MT110 or EETA501, and various other amp meters should be available through local tool suppliers.

Reconnect the battery cables.

Following the manufacturer's directions, connect the variable load tester (carbon pile) across the battery terminals. *Stevens* model LB-85 and *Snap-On* model MT540D are examples of testers available.

#### ⚠ WARNING

**Excessive battery discharge rates might overheat battery causing electrolyte gassing. This might create an explosive atmosphere. Always work in a well ventilated area.**

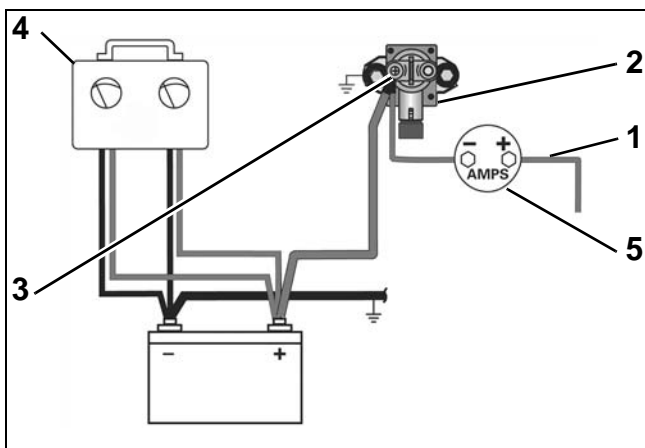

**Variable Load Test Diagram**

002077

1. Red wire (alternator output from EMM)
2. Starter solenoid
3. Battery cable terminal (B+)
4. Variable load tester
5. Ammeter

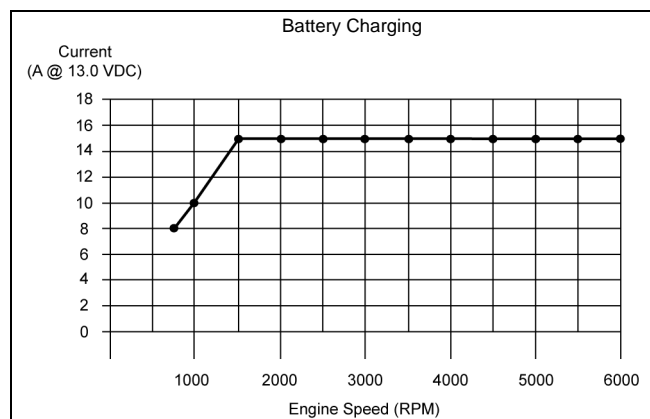

**Battery Charging Graph**

007352

Start and run the outboard at approximately 5000 RPM. Use the variable load tester to draw the battery down at a rate equivalent to the stator's full output.

- The ammeter should indicate nearly full output, approximately 15 A @ 5000 RPM.

**Note:** When the battery charge module is at full load, it is normal for the 55 V circuit to experience a voltage drop of up to 2 VDC.

Decrease the battery load toward 0 A.

- Ammeter should show a reduced output. As the current draw decreases, the battery voltage should stabilize at approximately 14.5 V.
- If results vary, check stator and alternator circuit **BEFORE** replacing the battery charge module. Refer to **STATOR TESTS** on p. 89 and **55 V Alternator Circuit** on p. 93.

## 55 V Alternator Circuit

Check battery ground cable for continuity.

With the key switch ON, check battery voltage at battery (12 V).

Then, use Electrical Test Probe Kit, P/N 342677, and a digital multimeter set to read 55 VDC to check voltage on white/red wires at the *EMM* connector. Voltage at *EMM* connector should be 0.5 to 1 V less than battery.

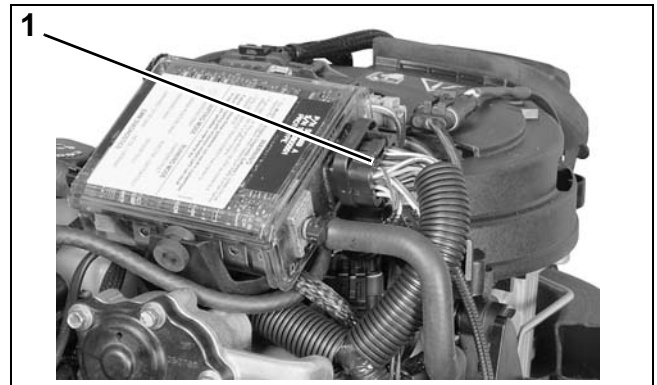

1. *EMM* connector

007353

With outboard running at 1000 RPM, voltage on white/red wires should be 55 V. Voltage readings at a specific speed (RPM) should be steady.

If there is any other reading, refer to **STATOR TESTS** on p. 89. Inspect the stator wiring and connections. Repair the wiring or replace a faulty stator, or *EMM*.

# ELECTRIC START CIRCUIT

## Start Circuit Diagram

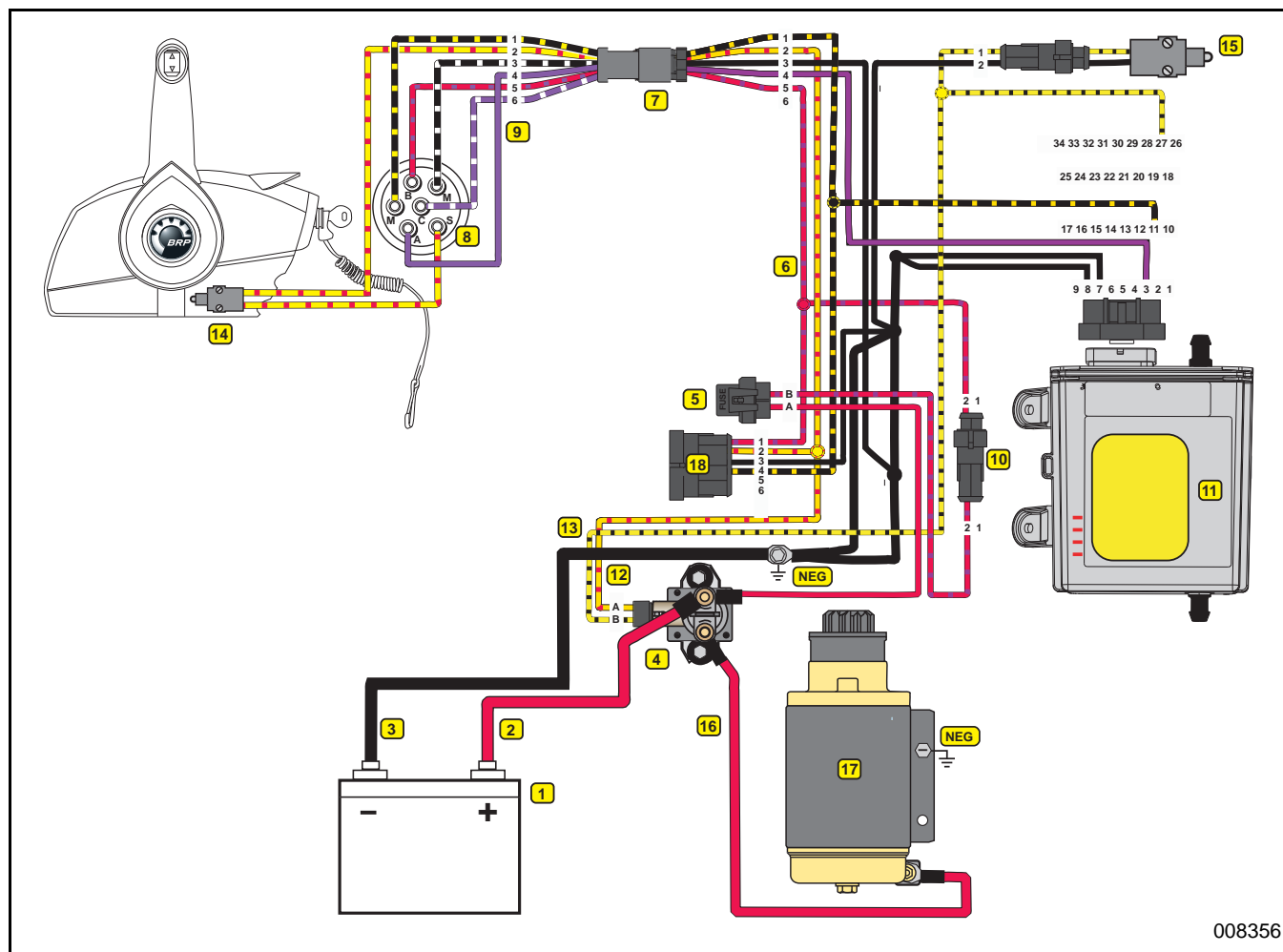

- |  |  |
|--|--|
| <ol style="list-style-type: none"> <li>1. Marine battery</li> <li>2. RED wire (POS)</li> <li>3. BLACK wire (NEG)</li> <li>4. Starter solenoid</li> <li>5. Fuse (10 amp)</li> <li>6. RED/PURPLE wire</li> <li>7. Key switch connectors</li> <li>8. Ignition switch</li> <li>9. PURPLE wire (switched B+)</li> </ol> | <ol style="list-style-type: none"> <li>10. Battery charge module connector</li> <li>11. Engine Management Module (EMM)</li> <li>12. YELLOW/RED wire, start</li> <li>13. YELLOW/BLACK wire, start signal ground</li> <li>14. Neutral Safety Switch (remote control)</li> <li>15. Neutral Safety Switch (engine)</li> <li>16. RED starter motor cable</li> <li>17. Electric starter motor</li> <li>18. Tiller harness connector</li> </ol> |
|--|--|

008356



## Start Circuit Operation

The starter must engage and turn the flywheel. The outboard must crank a minimum of 300 RPM to start.

Starter performance depends on the following:

- Proper battery and cable capacity.
- Clean, tight cable connections.
- Solenoid activation through the key switch and neutral safety switch.

Refer to **Predelivery and Installation Guide** for battery, terminal, and cable requirements.

## Solenoid Wiring

The positive (B+) battery cable connects to a large terminal of the starter solenoid. This terminal also provides the 12 V power supply to the engine harness (red wire) and the 10 A fuse. The red/purple wire from the fuse holder (10 A) provides 12 V to terminal “B” of key switch.

The negative (B-) battery cable connects to the main ground stud on the starter housing.

## Engine Wire Harness

Contains the following circuits:

- Red/purple output wire from fuse provides 12 V to instrument harness.
- Purple wire provides switched 12 V to *EMM*.
- Yellow/red wire provides switched 12 V to solenoid (terminal “A”).
- Yellow/black wire provides ground (NEG) to starter solenoid (terminal “B”).

## Instrument Wire Harness

Contains the following circuits:

- Red/purple wire provides 12 V to key switch terminal “B”.
- Purple wire provides switched 12 V to engine wire harness.
- Yellow/red wire from terminal “S” of key switch provides switched 12 V to solenoid (terminal “A”) (key switch in START position).

## Key Switch, ON position

12 V is applied to the accessory circuit. Key switch ON:

- Switches 12 V to terminal “A” of key switch and to the purple wires of the wire harnesses.
- Provides 12 V input to terminal 3 of *EMM* J1-A connector. *EMM* turns ON.

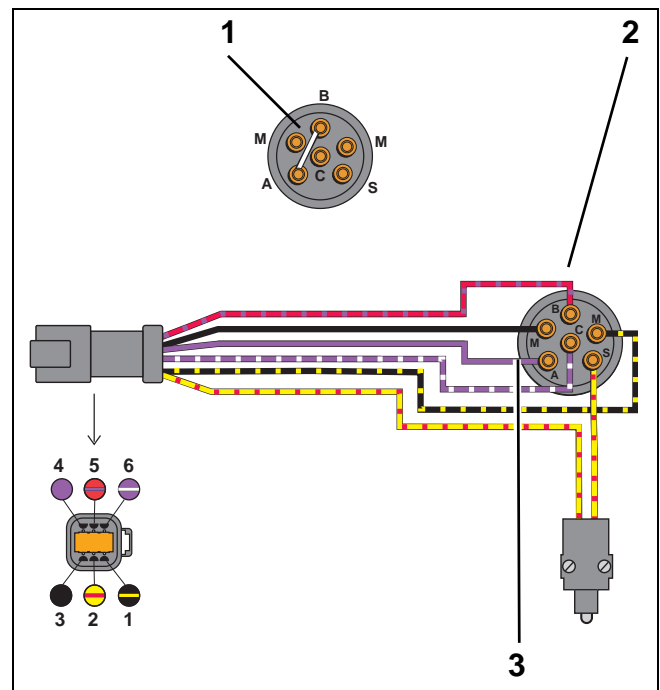

1. Key switch, ON position – Continuity between terminals “B” and “A”
2. Terminal “B”, 12 V (Red/purple)
3. Terminal “A”, 12 V (Purple)

## ELECTRICAL AND IGNITION

### ELECTRIC START TESTS

#### Key Switch, START Position

Key switch START:

- Switches 12 V to terminal “S” of key switch and to the neutral safety switch (in remote control).
- A closed neutral safety switch provides 12 V to the engine wire harness yellow/red wire and solenoid (terminal “A”).

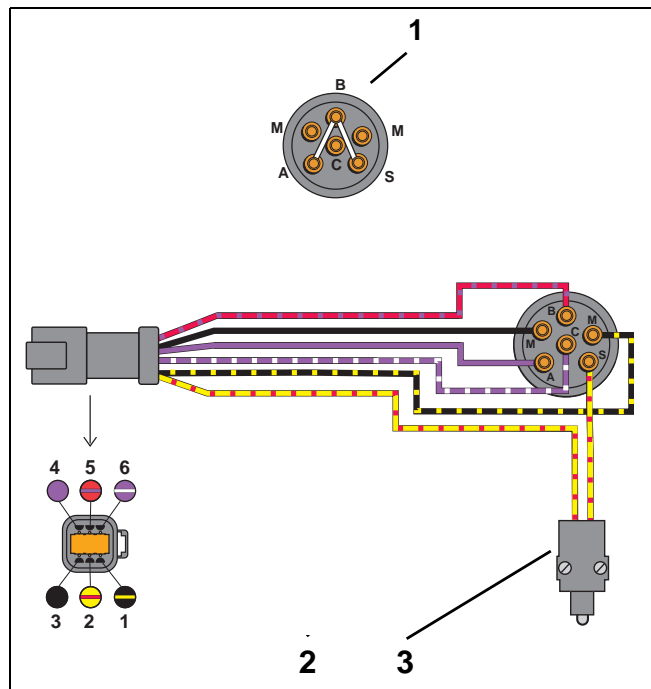

1. Ignition switch, START position – Continuity between terminals “B” and “A”; “B” and “S”
2. Terminal “S”, 12 V
3. Neutral safety switch

000691R

## ELECTRIC START TESTS

### Starter Solenoid Test

Disconnect the B+ (POS) battery cable at the battery.

**IMPORTANT:** Disconnect all wiring from solenoid terminals before proceeding with this test.

Use a digital multimeter to measure resistance.

Put one meter lead on the starter positive (+) cable terminal and the other lead on the battery positive (+) cable terminal:

- Meter must not show continuity (high reading).
- If meter shows continuity (low reading), replace the solenoid.

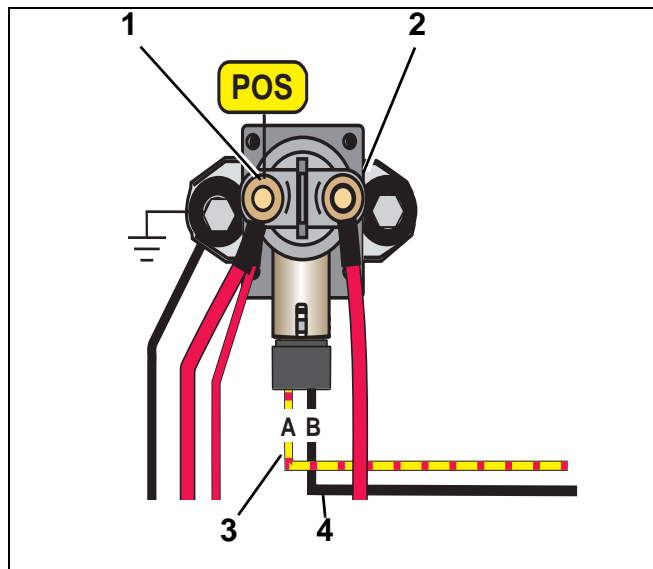

1. Battery positive cable (B+) terminal
2. Starter positive (+) cable terminal
3. “A” terminal (yellow/red)
4. “B” terminal (black)

002073

Apply B+ to terminal “A” of solenoid and ground (NEG) to terminal “B” of solenoid. Measure resistance between the starter positive (+) cable terminal and the positive battery (+) cable terminal.

- The solenoid must close with an audible click.
- Meter must show continuity (low reading).
- If meter shows no continuity (high reading), replace the solenoid.

After re-installing the solenoid, coat all wires and terminals with *Black Neoprene Dip*.

## Starter Voltage Drop Test

### ⚠ WARNING

To prevent accidental starting of outboard, disconnect crankshaft position sensor (CPS).

Use a digital voltmeter to measure the voltage drop on each section of the start circuit.

If any voltage reading is greater than 0.5 VDC check that connections are clean, tight and free of corrosion. Clean or replace any corroded or damaged cables or connections.

**STEP 1:** Connect voltmeter positive (+) lead to the terminal for the negative (-) battery cable at powerhead. Connect voltmeter negative (-) lead to negative (-) battery post.

- Activate starter motor and observe voltage reading.

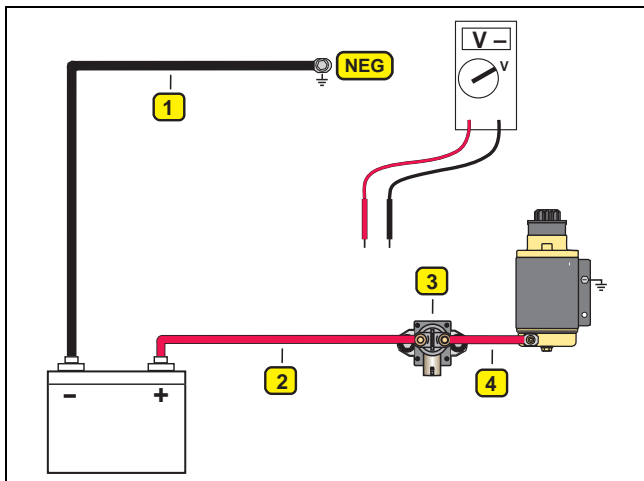

1. Negative battery cable
2. Positive battery cable
3. Solenoid
4. Starter cable

008464

**STEP 2:** Connect positive (+) lead to battery positive (+) terminal. Connect negative (-) lead to starter solenoid terminal.

- Activate starter motor and observe voltage reading.

**STEP 3:** First, activate starter motor. Connect positive (+) lead to starter solenoid terminal. Connect negative (-) lead to opposite starter solenoid terminal.

- Observe voltage reading.

**STEP 4:** Connect positive (+) lead to starter cable of solenoid terminal. Connect negative (-) lead to starter motor terminal.

- Activate starter motor and observe voltage reading.

## No Load Current Draw Test

Securely fasten starter in a vise or suitable fixture before proceeding with this check.

Use a battery rated at 500 CCA (60 amp-hr) or higher that is in good condition and fully charged.

Use an inductive ammeter or connect a 0 to 100 amp ammeter in series with a heavy jumper between the battery positive (+) terminal and the starter positive (+) terminal.

Fluke model 334 or 336, Snap-On model MT110 or EETA501, and various other ammeters should be available through local tool suppliers.

Attach or hold a vibration tachometer, such as a *Frahm*<sup>†</sup> Reed tachometer, to the starter.

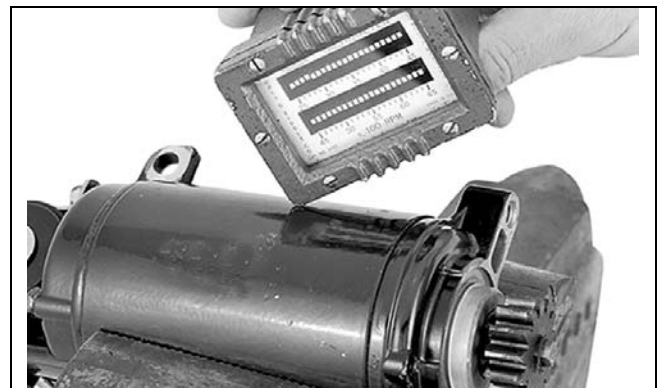

24083

Complete the circuit with a heavy jumper between the battery negative (-) terminal and the starter frame.

Monitor the starter RPM and current draw.

- At 10,500 RPM the ammeter should show a maximum of 30 A.

# REMOTE CONTROL SWITCH TESTS

## Key Switch Test

Refer to **Wiring Diagrams** at back of manual.

Use an ohmmeter or a continuity light to test key switch operation. Replace switch if results are incorrect with any of the following tests.

**IMPORTANT:** Disconnect battery and key switch wiring before proceeding with the following tests.

**Stop/Ground Terminals (M)** – Connect meter between the two “M” terminals. Meter must indicate NO continuity at START or ON.

Turn key switch OFF. Meter must indicate continuity.

**Accessory Terminal (A)** – Make sure the key switch is OFF. Connect the ohmmeter or continuity light between terminals “B” (battery) and “A” (accessory) of key switch. Meter must indicate NO continuity.

Turn switch ON. Meter must indicate continuity.

Turn key switch to START. Meter must continue to indicate continuity.

**Starter Terminal (S)** – Hold key switch at START. Connect meter between terminal “B” and terminal “S.” Meter should indicate continuity.

**IMPORTANT:** The choke function or terminal “C” of the key switch is NOT used.

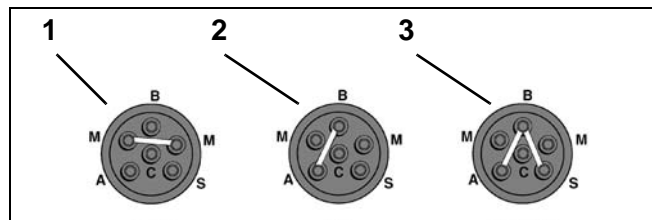

1. OFF  
 2. ON  
 3. START  
 000443R

## Neutral Start Circuit Test

Use an ohmmeter or continuity light to test the continuity of the circuit while positioning the remote control in NEUTRAL, FORWARD, and REVERSE.

**IMPORTANT:** Turn propeller shaft or disconnect shift cable to allow proper remote control shift action while outboard is not running. Disconnect the instrument harness connector from the key switch harness connector.

Make sure the remote control handle is in NEUTRAL. Connect meter between terminal 5 (red/purple wire) and terminal 2 (yellow/red wire). Turn the key switch to START. Meter must indicate continuity.

Move the remote control handle to FORWARD and turn the key switch to START. Meter must NOT indicate continuity.

Move the remote control handle to REVERSE and turn the key switch to START. Meter must NOT indicate continuity.

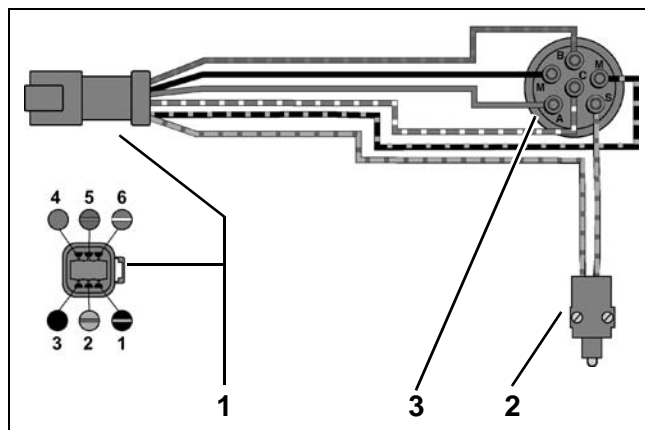

1. Key switch harness connector  
 2. Neutral start switch  
 3. Key switch

000443

**IMPORTANT:** Reconnect shift cable and instrument harness connector to key switch harness connector.

## Neutral Start Switch Test

Use an ohmmeter or a continuity light to test neutral start switch operation.

**IMPORTANT:** All wiring must be disconnected from the switch before proceeding with this test.

Disassemble the remote control and remove the neutral start switch.

Connect one meter lead to each terminal of the switch.

- Meter must indicate continuity when the plunger is depressed
- Meter must indicate no continuity when the plunger is released.

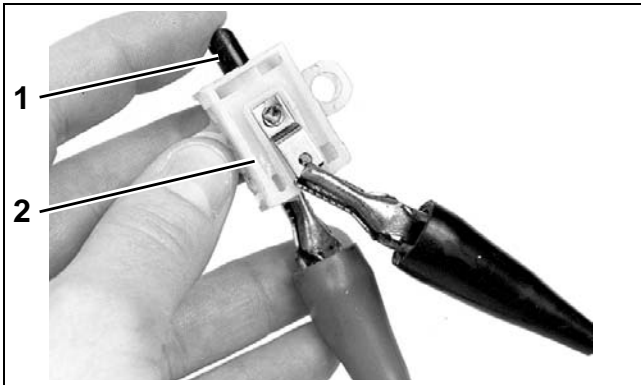

**TYPICAL**  
1. Plunger  
2. Neutral start switch

3224

Replace switch if results are incorrect.

## Emergency Stop Switch Test

This switch can be part of the key switch or installed as a separate switch. Either style connects the "M" terminals of the key switch.

The emergency stop switch function grounds the stop circuit wire (black/yellow) when the lanyard clip is removed. One "M" terminal is the ground wire (black) and one "M" terminal is the stop circuit wire (black/yellow).

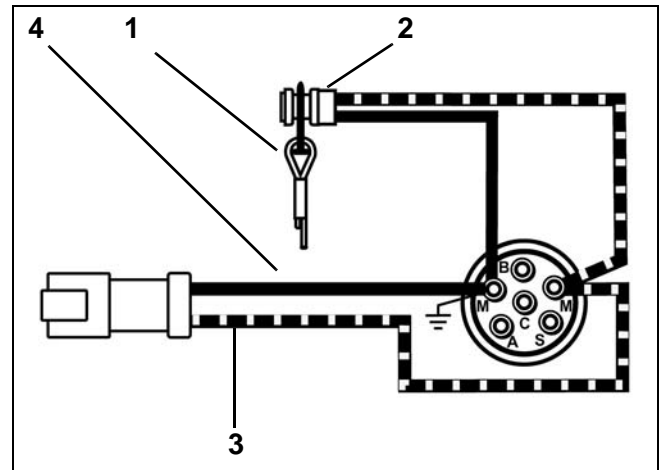

1. Lanyard and clip assembly  
2. Emergency stop switch, separate from key switch  
3. Stop circuit wire (black/yellow)  
4. Ground wire (black)

000444

Install the clip on the emergency stop switch or key switch. Start the outboard. Pull the clip from the switch. The outboard must stop running.

## TILT/TRIM RELAY TEST

The tilt and trim (TNT) module contains the circuitry and relays required for power trim and tilt operation.

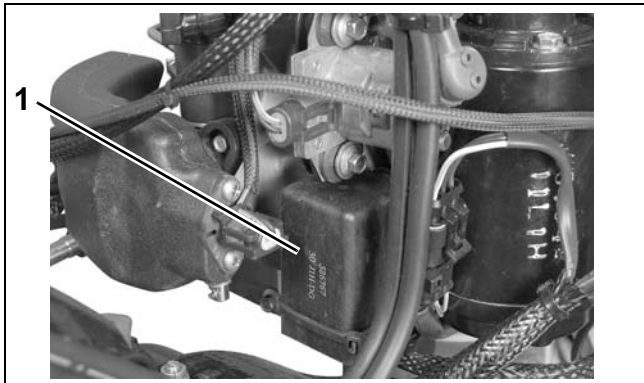

1. Tilt and trim module

007356

The tilt and trim switch provides B+ input to green/white or blue/white wire of the TNT module.

### Operation

The relay activates when B+ input from the switch is supplied to terminal 86 of the internal relays.

Terminal 87a connects to ground (B-).

Terminal 87 connects to B+.

Terminal 30 connects TNT motor.

Terminals 87a and 30 are connected when relay is not activated. This supplies ground (B-) connection to TNT motor.

Terminals 87 and 30 are normally open. B+ is applied to terminal 30 when relay is activated. This supplies ground B+ connection to TNT motor.

Refer to **Tilt and Trim Module Diagram**.

### Test Procedure

Make sure red and black wires are connected to 12 V battery power supply.

Set voltmeter to 12 VDC scale. Connect test leads to terminals “A” and “B” of TNT motor connector.

Use a wire jumper to alternately connect B+ to terminals “1” and “2” of tilt and trim switch connector.

The meter must indicate battery voltage (12 V) with B+ connected to either terminal.

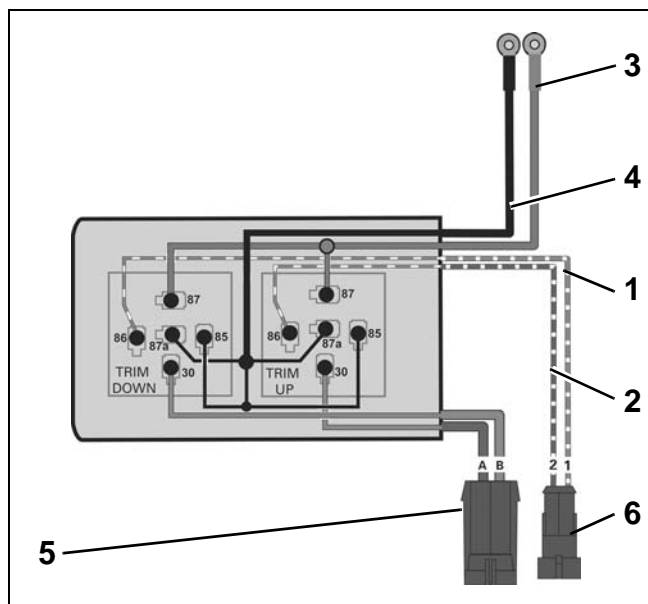

**Tilt and Trim Module Diagram**

002063

1. Green/white wire
2. Blue/white wire
3. B+, red wire
4. B-, black wire
5. TNT motor connector
6. TNT switch connector

## SystemCheck CIRCUIT TESTS

*Evinrude E-TEC* 15–30 hp models only provide warning for a “LOW OIL” condition.

Check the condition of the warning system and associated wiring and connections. Test the engine monitor regularly and anytime you suspect an alert situation has been missed.

The instrument harness must be connected to the outboard before performing the following tests. Refer to the **Engine Wiring** diagram and the **MWS Instrument Wiring** diagram in the back of this manual.

**IMPORTANT:** Use jumper wires made with the appropriate terminals to test the warning circuits.

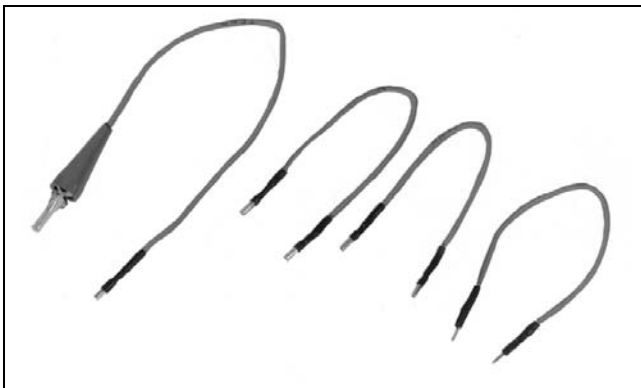

42811

### Gauge Self-Test Check

Turn the key switch to ON with the outboard NOT running. The gauge warning lights for NO OIL, WATER TEMP, CHECK ENGINE, and LOW OIL must all light at once, then turn off in sequence, and the warning horn must sound for one-half second.

If the gauge lights do not turn on, turn the key switch OFF. Disconnect the gauge 8-pin connector from the back of the gauge and turn the key switch ON. Test for battery voltage between

instrument harness terminal 1 (purple wire) and terminal 2 (black wire).

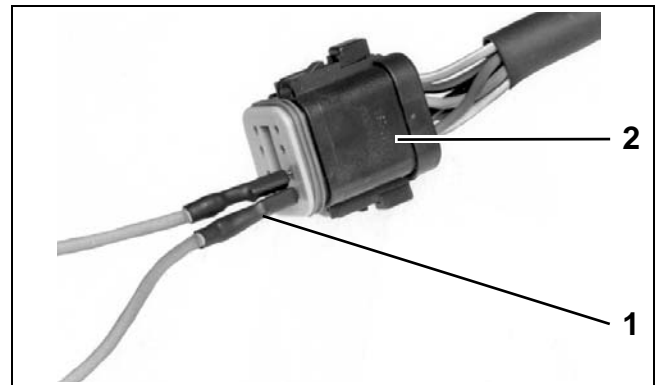

1. Test adapter(s)  
2. Connector, SystemCheck gauge

42761

- If battery voltage is present, replace the gauge.
- If there is no battery voltage, check that 12 V is present at terminal “B” of the key switch. Check condition of the instrument harness, key switch, and connections.

If the lights worked, but the warning horn did not sound for one-half second, turn the key switch OFF. Disconnect the warning horn 2-pin connector. Substitute a known good warning horn. Turn the key switch ON.

- If the substitute horn beeps, the original horn is defective and must be replaced.
- If the substitute horn does not beep, check for battery voltage between instrument harness 2-pin connector, terminal 2 (purple wire) and ground with the key switch ON. Also, check the tan/blue wire for continuity between pin 8 of the 8-pin connector and pin 1 of the 2-pin connector.
- If battery voltage is present at the purple wire and the tan/blue wire has continuity between

## ELECTRICAL AND IGNITION

### SystemCheck CIRCUIT TESTS

the two connectors, replace *SystemCheck* gauge.

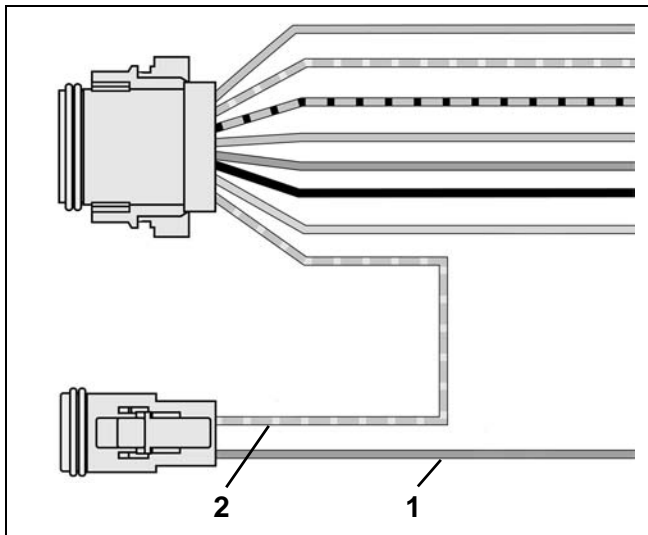

1. Purple wire
2. Tan/blue wire

DRC6280

Turn the key switch OFF and reconnect all disconnected circuits.

## LOW OIL Circuit Test

Turn the key switch ON. Using a jumper wire, connect tan/black wire (pin 4) of the engine harness connector to a clean engine ground. The LOW OIL light should turn on after 40 seconds.

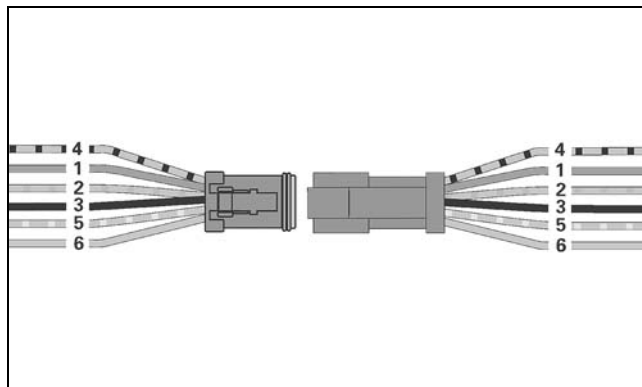

002079

If the LOW OIL light does not turn on after connecting the terminal to ground, test circuit for continuity.

Turn the key switch OFF and reconnect all disconnected circuits.



## TACHOMETER CIRCUIT TESTS

Check voltage at the battery. Use this reading as a reference for battery voltage.

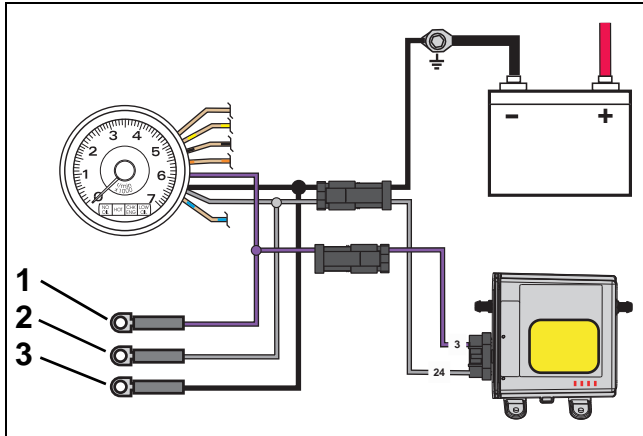

1. Purple lead
2. Gray lead
3. Black lead

007357

Connect the red meter lead to the tachometer purple wire and the black meter lead to the tachometer black wire (key ON, outboard NOT running).

- If meter shows battery voltage, go to next step.
- If meter shows less than battery voltage, check the purple, red/purple, and black wiring circuits; fuse, key switch, and battery connections.

Disconnect gray and black wires at tachometer. Set *Fluke 29 Series II* meter, or equivalent, to Hz scale. Connect meter between gray wire and black wire. With outboard running at 1000 RPM, meter should indicate 90 to 105 Hz.

- If meter reads 90 to 105 Hz, replace tachometer.
- If meter reads low or no signal, confirm output on gray wire at pin 24 of *EMM J1-A* connector.
  - Reading OK – Check condition of tachometer circuit (gray wire). Repair as needed.
  - Reading not OK – Check connection at *EMM*; replace faulty *EMM*.

## FLYWHEEL AND STATOR SERVICING

**IMPORTANT:** Weak flywheel magnets can cause low alternator output and affect outboard performance. Weak flywheel magnets can also cause low readings on ignition test equipment, such as a peak-reading voltmeter, which might cause unnecessary parts replacement.

An accurate test of alternator output can help determine the flywheel's condition. Refer to **CHARGING SYSTEM TESTS** on p. 91.

### Flywheel Removal

#### **⚠ WARNING**

To prevent accidental starting while servicing, disconnect the battery cables at battery.

Remove the recoil starter assembly. Refer to **RECOIL STARTER REMOVAL** on p. 281.

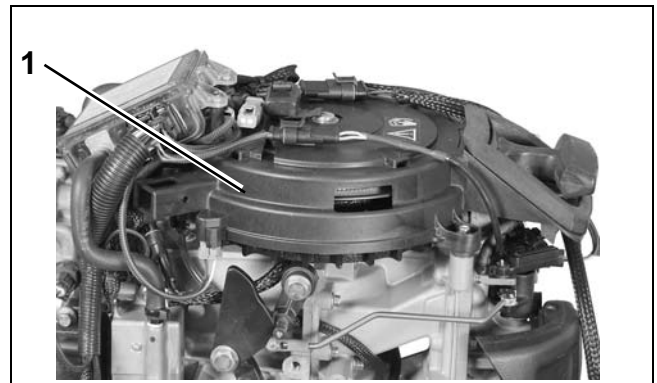

1. Recoil Starter

007358

## ELECTRICAL AND IGNITION

### FLYWHEEL AND STATOR SERVICING

Use Flywheel Holder, P/N 771311, or equivalent, and a 28 mm socket to remove flywheel nut.

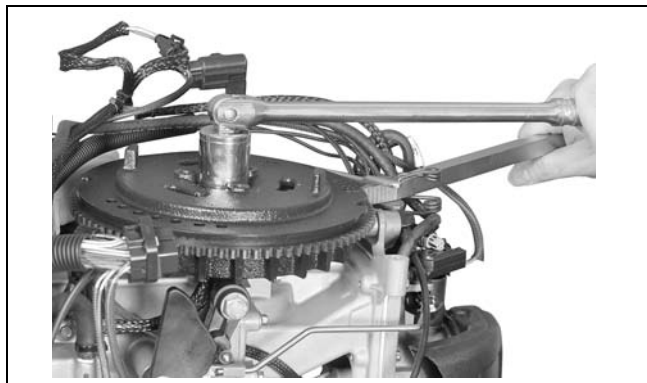

007359

Apply *Moly Lube* grease to the threads of the puller pressing screw, P/N 307637, and the center hole of the crankshaft.

Assemble the following components from Universal Puller Set, P/N 378103:

- Body, P/N 307636
- Screw, P/N 307637
- Handle, P/N 307638
- Three screws P/N 309492
- Three washers, P/N 307640

Put the puller on flywheel with body flat side up. Attach the puller body with the three shoulder screws and washers. Hold puller body with handle, and tighten pressing screw until flywheel releases. Turn the center screw and lift the flywheel off of the crankshaft.

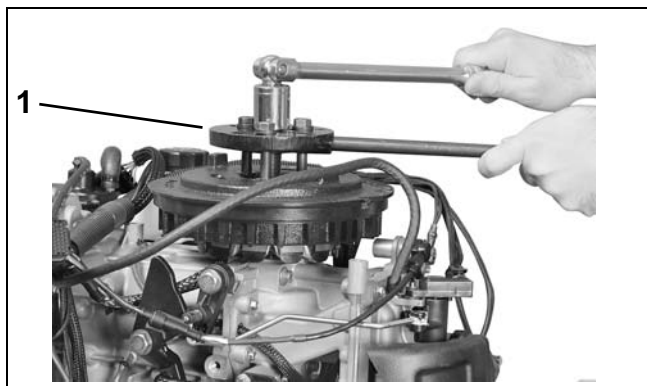

1. Universal puller

007360

## Stator Service

Disconnect stator harness connector.

Remove three allen head screws to remove stator.

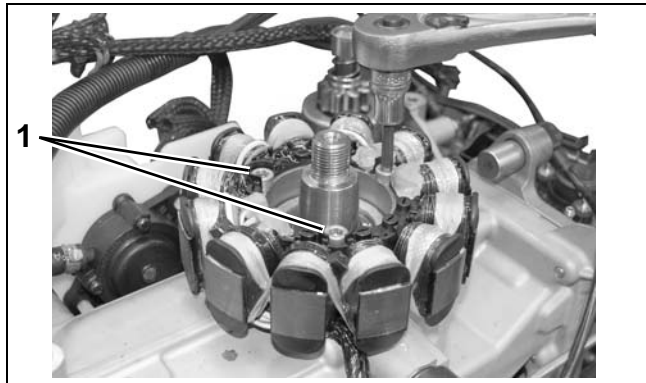

1. Stator screws

007443

To install stator, position stator on cylinder block. Apply *Nut Lock* to screw threads. Install screws and tighten in crossing pattern to a torque of 84 to 106 in. lbs. (9.5 to 12 N-m).

## Flywheel Installation

### CAUTION

To avoid injury, keep hands and fingers clear from underside of flywheel. Flywheel can snap toward stator with great magnetic force.

Install the outer edge of flywheel key parallel with centerline of crankshaft.

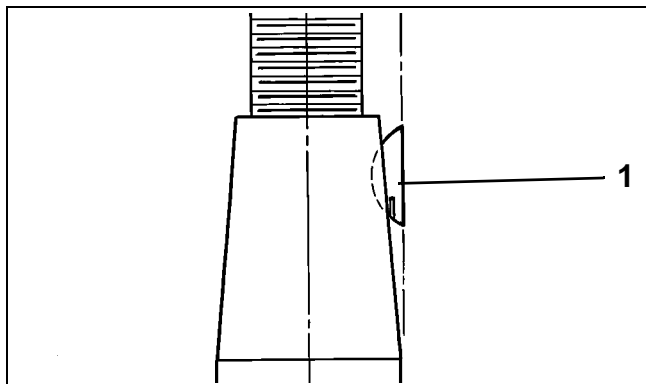

1. Flywheel key

DRC2116

Thoroughly clean the crankshaft and flywheel tapers with *Cleaning Solvent™* and let dry.

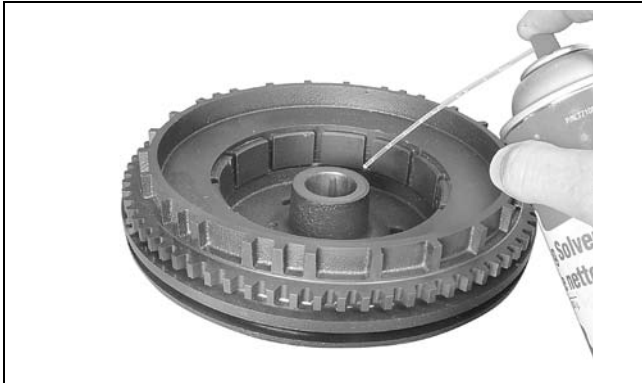

002093

Align the flywheel keyway and install flywheel.

Coat the threads of the flywheel nut with *Triple-Guard* grease.

Install the washer and nut and tighten to a torque of 66 to 70 ft. lbs. (90 to 95 N-m).

**NOTICE** To prevent damage to crankcase or cylinder block, DO NOT allow Flywheel Holder to rest against recoil starter mounting boss.

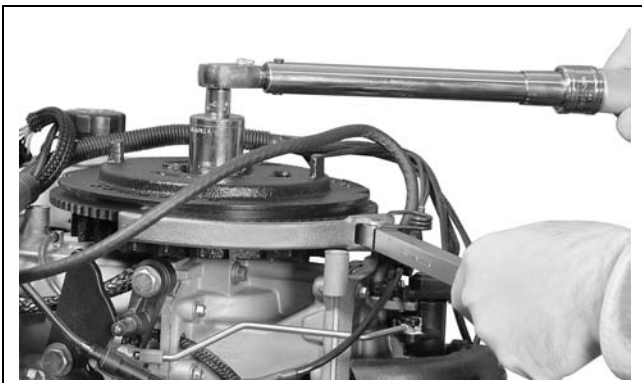

007361

Replace recoil starter.

**IMPORTANT:** Check ignition timing after flywheel removal or replacement. Refer to **TIMING ADJUSTMENTS** on p. 106.

## IGNITION COIL SERVICING

### Ignition Coil Removal

Remove spark plug lead from ignition coil and disconnect ignition coil electrical connector.

Remove two ignition coil retaining screws.

Do not lose the rubber washers between coil and bracket.

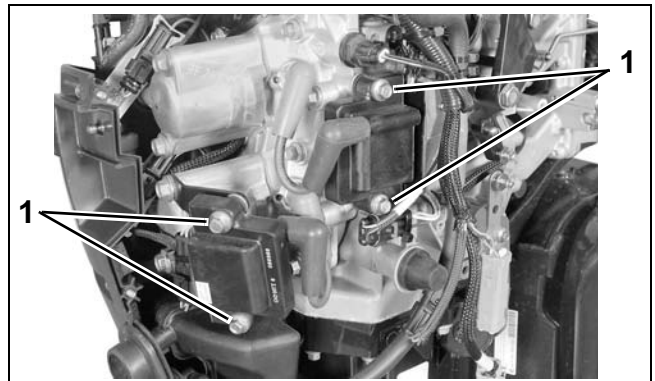

1. Screws

008193

6

### Ignition Coil Installation

Install one rubber washer on each screw and install screw through ignition coil.

Install remaining rubber washers on screws between coil and bracket.



1. Rubber washers

008188

Install coil on bracket. Tighten screws to a torque of 31 to 49 in. lb. (3.5 to 5.5 N-m).

Install spark plug lead on ignition coil and connect ignition coil electrical connector.

## TIMING ADJUSTMENTS

### Timing Pointer

The timing pointer on *Evinrude E-TEC 15 – 30 HP* models is not adjustable.

### Timing Verification

Use *Evinrude Diagnostics* software to synchronize the mechanical timing of the outboard with the electronic timing of the *EMM*.

Start the outboard.

Use the *Settings/Ignition Timing* screen of the diagnostics software and follow the on-screen instructions.

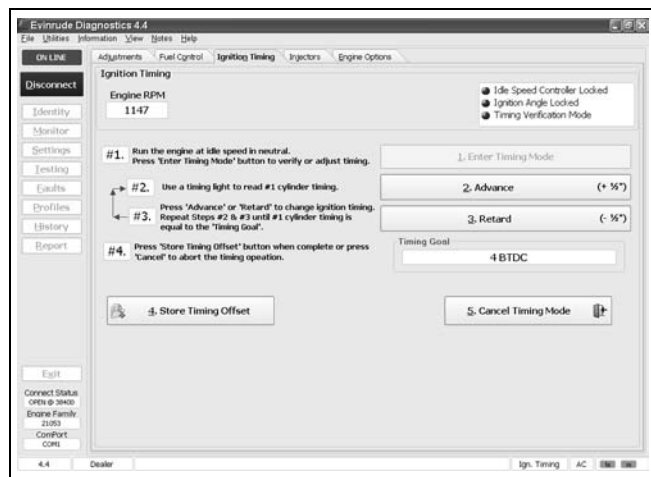

Ignition Timing Screen

008143

Check ignition timing after any of the following procedures:

- Powerhead replacement
- Crankshaft replacement
- Flywheel removal or replacement
- CPS replacement
- *EMM* replacement
- *EMM* software replacement (reprogramming)

**IMPORTANT:** Make sure the timing pointer is set and the outboard reaches operating temperature before making any timing adjustments.

### TPS Calibration

Use *Evinrude Diagnostics* software to tell the *EMM* what throttle position sensor voltage is when the throttle plates begin to open.

Set TPS Calibration after replacing or adjusting any throttle body or throttle linkage parts.

Remove the air silencer.

Do NOT start the outboard.

On the *Settings/Adjustments* screen of the diagnostics software, click the “Set TPS Calibration” button.



1. TPS Calibration button

008144

While holding the throttle plates closed, advance the throttle linkage until it stops. The *Measured TPS Calibration* field on the screen will increase.

Click the *Working* button in the software to calibrate the TPS.

Install the air silencer.

# ELECTRIC STARTER SERVICING

## Starter Removal

**IMPORTANT:** Do not clean the starter drive while the starter motor and drive are installed on the powerhead. The cleaning agent could drain into the starter motor, washing dirt from the drive into the starter bearings and commutator.

Disconnect the battery cables at the battery.

Remove lower motor covers. Refer to **Lower Cover Removal** on p. 45.

Remove the starter positive (+) cable from post on starter.

Remove three starter mounting screws. Remove the starter.

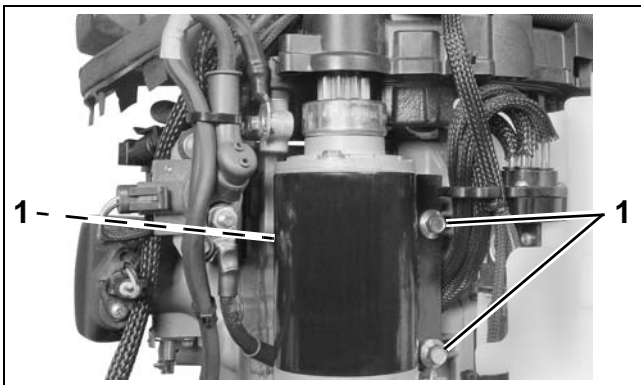

1. Screws

007253

## Starter Disassembly

Remove the retaining nut, spacers, spring and starter pinion from pinion shaft.



007438

007439

Mark the end cap and brush holder cap orientation. Remove the two thru-bolts.



002296

Remove the end cap and thrust washer.



002298

## ELECTRICAL AND IGNITION

### ELECTRIC STARTER SERVICING

Remove brush holder cap from armature and frame assembly. Do not lose the brush springs.



002299

Slowly, remove the armature from frame.



38288

### Starter Cleaning and Inspection

Inspect the brushes for wear and damage. Replace brushes if damaged or worn. Replace weak brush springs.



002301

Clean the commutator with 300-grade emery cloth. If commutator surface is unevenly worn or pitted, turn it on a lathe. Remove any trace of oil or metal dust from commutator.

Check the armature on a growler for shorted turns using a test light or meter. Inspect armature insulation for indications of overheating or damaged windings. Clean off any carbon deposits or foreign matter which could contribute to failure of windings.

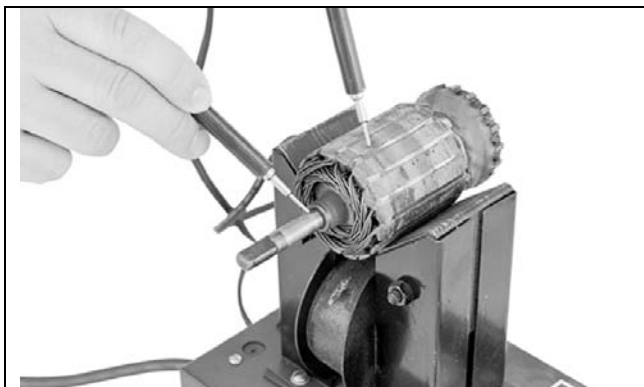

TYPICAL

24058

Check permanent magnets and make sure they strongly attract any steel or iron object held inside frame. Weak magnetism could cause excessive RPM on **No Load Current Draw Test** on p. 97.



TYPICAL

24057

After disassembling the drive, clean each part with *Cleaning Solvent* and inspect for wear and distortion.

If the pinion does not properly engage the flywheel, the pinion and screw shaft assembly could be worn, distorted, or dirty. Locate the cause of binding and correct it before completing the assembly.

Inspect and replace end cap thrust washer if distorted or worn excessively.

## Starter Assembly

**IMPORTANT:** If removed, apply *Locquic Primer* and *Screw Lock™* to the brush card screws before installing.

Place armature in frame.

Apply *Moly Lube* to the armature bushing.

Route the brush leads and install the springs and brushes.

**IMPORTANT:** Incorrect orientation of the brushes could damage the starter or cause reverse rotation.

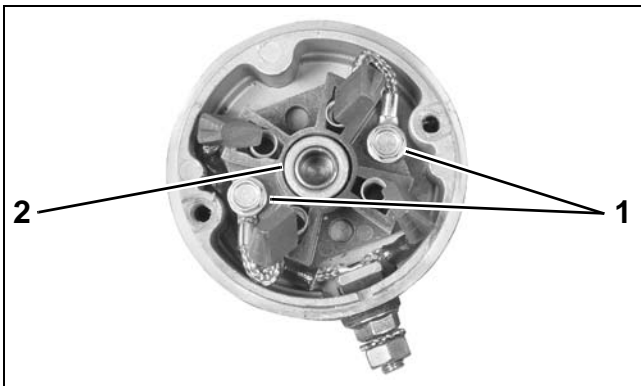

1. Brush card screws
2. Armature bushing

002300

Compress the brushes and springs with a modified putty knife.

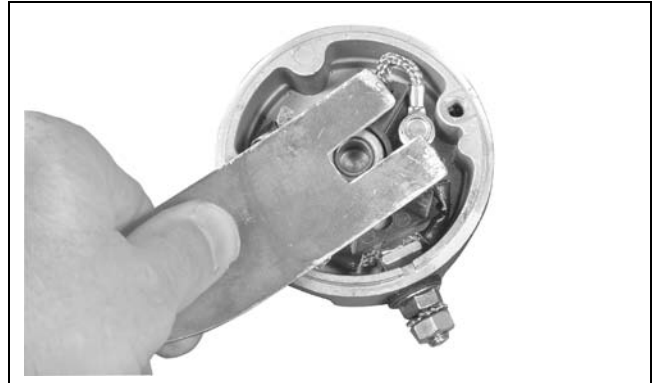

002309

Align and place brush holder cap firmly on armature and slide putty knife out, making sure the brushes are retained properly.



002310

Install thrust washer. Align and place end cap onto armature shaft.



002308

## ELECTRICAL AND IGNITION

### ELECTRIC STARTER SERVICING

Apply *Locquic Primer* and *Screw Lock* to the threaded portion, and install the two thru-bolts. Tighten bolts to a torque of 100 to 110 in. lbs. (11 to 12.5 N·m).



002306

Lubricate the splines (helix) of starter pinion shaft with *Starter Bendix Lube*. DO NOT use liquid or aerosol spray lubricants.



002307

Install pinion, spacer and spring.



007440

Install spacer and retaining nut. Tighten nut to a torque of 20 to 24 ft. lbs. (27 to 33 N·m).

Be sure spacer is not caught between shaft and retaining nut and that spacer is free to move.

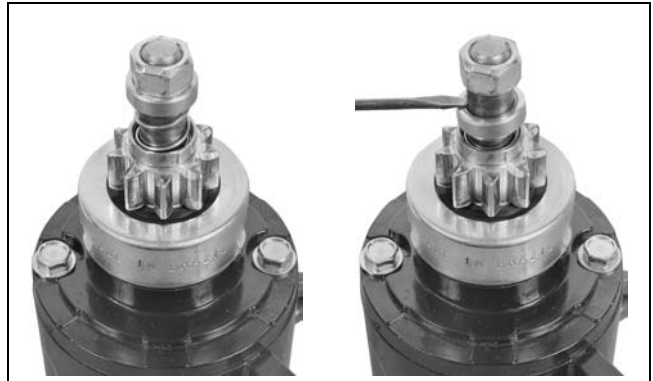

007441

007442

To test the assembly and operation of the starter, refer to **No Load Current Draw Test** on p. 97.



## Starter Installation

Apply *Triple-Guard* grease to the threads of the three starter screws and also to the washers.

Position the starter and install the screws and washers. Tighten screws to a torque of 168 to 192 in. lbs. (19 to 21 N·m).

Attach starter positive (+) cable to post with lock washer and nut; tighten securely.

Coat connections with *Black Neoprene Dip*.



007355

# CONNECTOR SERVICING

## DEUTSCH Connectors

**IMPORTANT:** *Electrical Grease* is recommended. Incorrect grease application can cause electrical or warning system problems.

To disconnect the connector, press the latch and pull the connectors apart.

To connect the connector, confirm that the seal is in place. Clean off any old grease and dirt from connectors. Apply a light coat of *Electrical Grease* to seal only. Push connectors together until latched.

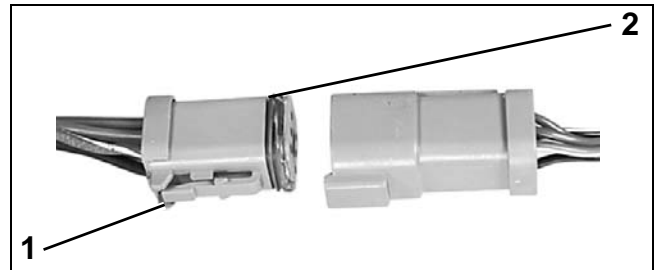

1. Latch
2. Seal

42079A

6

## Terminal Removal

Use hook-end of Connector Service Tool, P/N 342667, to pull out wedge from receptacle, or use other end of tool to pry out wedge from plug. Use needle-nose pliers to remove wedge from 3-pin receptacle.

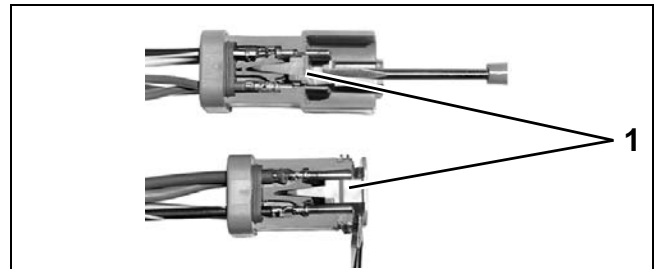

1. Wedge

42327

## ELECTRICAL AND IGNITION CONNECTOR SERVICING

Release terminal latch and gently pull on wire.

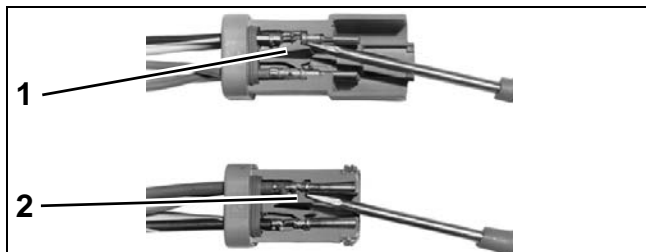

1. Terminal latch (plug)
2. Terminal latch (receptacle)

42329

### Terminal Installation

Push terminal through seal until it locks into place. Fill connector with *Electrical Grease* to 1/32 in. (0.8 mm) below ledge or end of plug.

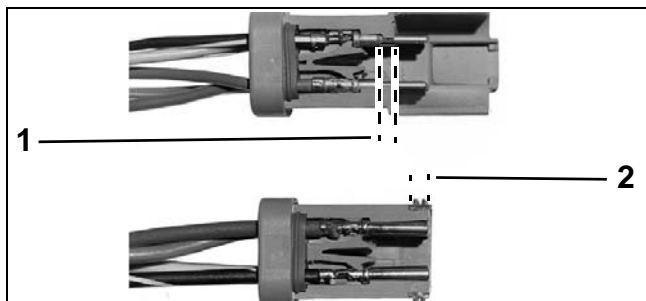

1. Ledge of plug
2. End of plug

42330

Push wedge in until latched. Wedge in 2-pin receptacle is not symmetrical; position latch shoulders next to terminals.

### Crimping Terminals

Strip insulation back 3/16 in. (5 mm). Place terminal in 18-gauge notch of Crimping Pliers, P/N 322696. Position end of wire strands in terminal past wire crimp area, and position end of insulation past insulation crimp area. Capture all wire strands in crimp; leave no loose strands. Crimp wire securely. Do not solder. Crimp insulation in 14/16-gauge notch of crimping pliers.

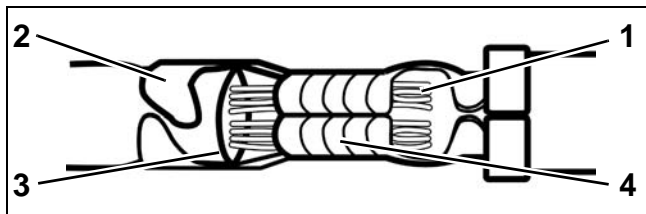

1. End of wire strands
2. Insulation crimp area
3. End of insulation
4. Wire crimp area

DRC6205

## AMP Connectors

**IMPORTANT:** Always use the appropriate meter test probes and adapters when testing components fitted with these terminals. Electrical grease is NOT used on AMP connectors.

### SUPERSEAL 1.5

#### Disconnect

Lift latch. Pull connectors apart.

#### Connect

Confirm the seal is in place. Push connectors together until latched.

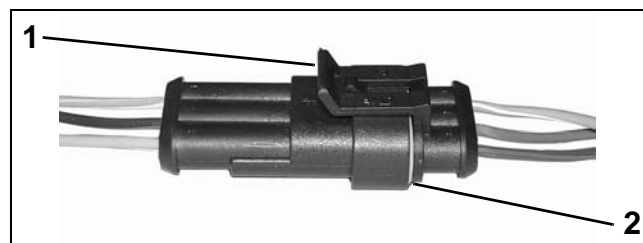

1. Latch
2. Seal

002448

### Terminal Removal

Use Secondary Lock Tool, P/N 777078, to release anti-backout device of connector housing. Next, use Primary Lock Tool, P/N 777077, to release locking tab of connector housing. Release locking tab and pull on wire to remove from connector housing.

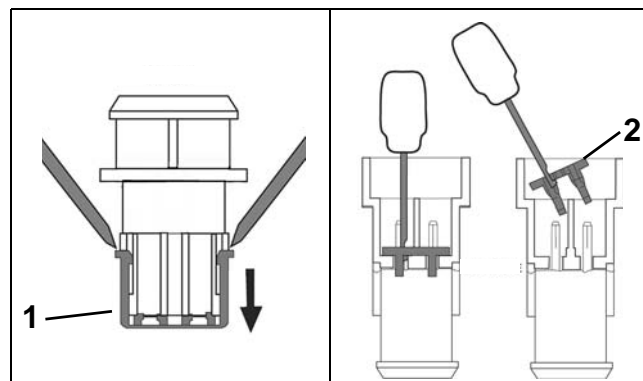

1. Anti backout device, plug
2. Anti backout device, receptacle

002449

002450

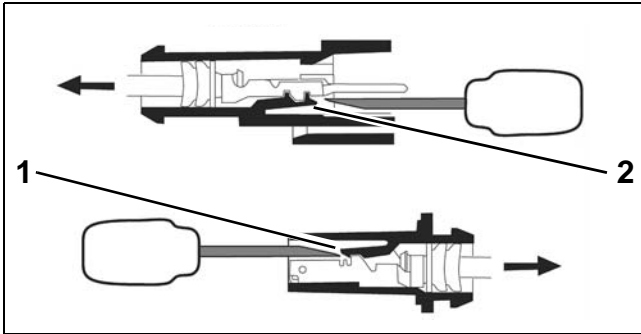

1. Locking tab, plug  
2. Locking tab, receptacle

002447

### Terminal Installation

Align terminal with connector housing. Push connector and seal into housing until seated.

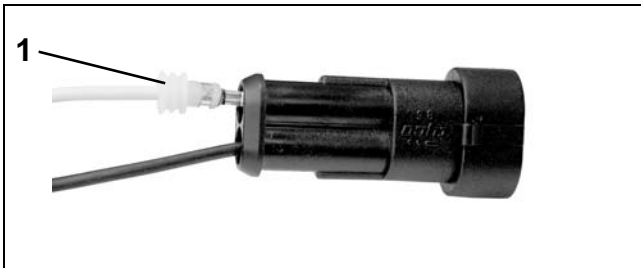

1. Terminal and seal

002451

Align anti-backout device with connector housing and terminals. Use Secondary Lock Installer, P/N 777079, to seat device in connector.

### Crimping Terminals

Crimping *Superseal 1.5* terminals requires *AMP Crimp Tool* with dies, P/N 777281.

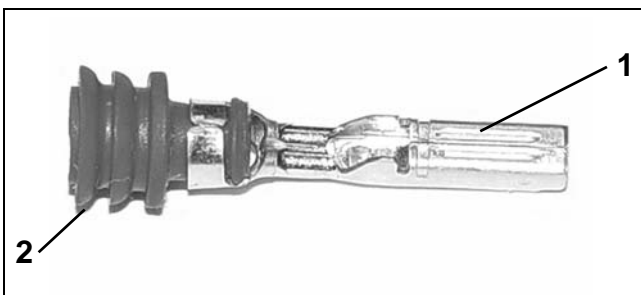

1. Terminal  
2. Seal

002452

### SUPER SEAL

The J1-A connector of the *EMM* is an *AMP Super Seal* connectors.

### Disconnect

Depress BOTH latches and pull connector from plug.

### Connect

Push connector into plug until latches engage.



1. Latch

007353

### Terminal Removal

Open lock mechanism and remove terminal from connector housing.

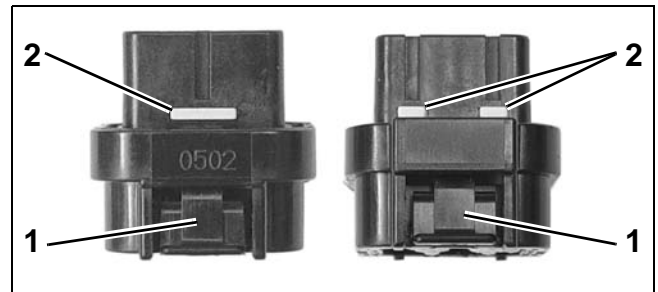

1. Latch  
2. Lock mechanism

002453

### Terminal Installation

Push terminal through seal until it is seated in connector housing. Close lock mechanism.

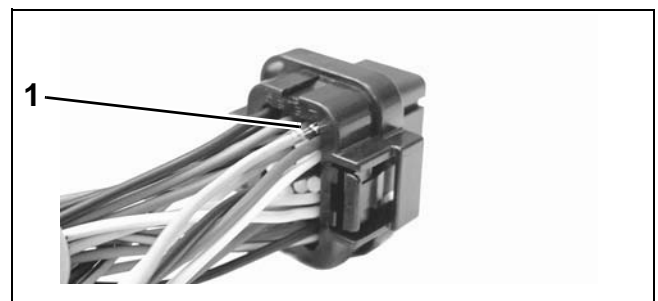

1. Terminal

002454

## ELECTRICAL AND IGNITION CONNECTOR SERVICING

### Packard Connectors

**IMPORTANT:** Always use the appropriate meter test probes and adapters when testing components fitted with these terminals.

#### Disconnect

Lift latch(s). Remove connector.

#### Connect

Confirm the seal is in place. Push connector onto housing until latched.

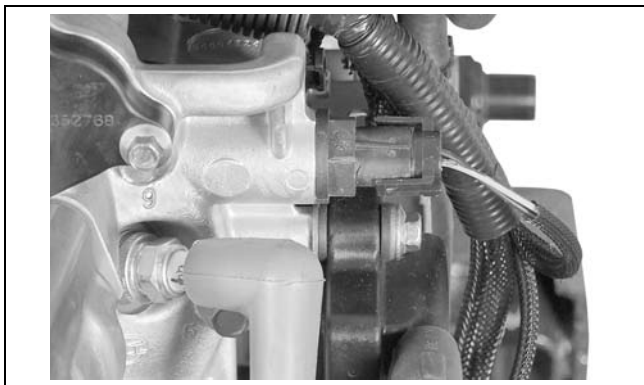

007364

#### Terminal Removal

A tab on the back side of the terminal engages a shoulder in the connector housing to hold the terminal in place. The terminal is removed by releasing the tab and then pushing the terminal and wire through connector housing.

Insert a thin tool into the connector above the terminal to release tab.

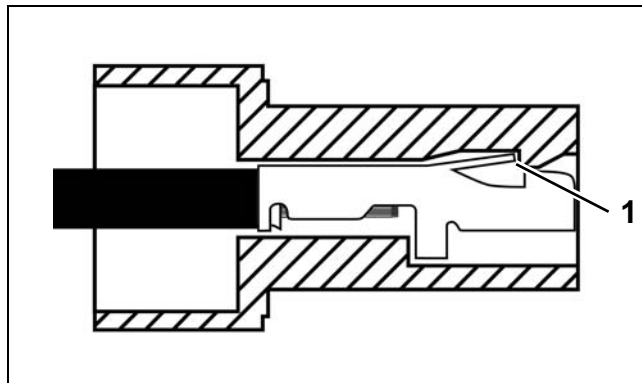

1. Tab

DRC5940a

#### Terminal Installation

Install wire gasket on wires and feed wires through the correct terminal position of the connector housing. Terminal is crimped onto wire and then pulled back into connector housing until locking tab engages and terminal is seated.



002304

#### Crimping Terminals

Strip insulation back 3/16 in. (5 mm). Position end of wire strands in terminal past the wire crimp area and the end of insulation in the insulation crimp area of the terminal.

Capture all wire strands in crimp; leave no loose strands. Crimp wire and insulation securely using crimping pliers.

# FUEL SYSTEM

## TABLE OF CONTENTS

SERVICE CHART .....	116
FUEL SYSTEM HOSE ROUTING .....	118
FUEL SYSTEM CIRCUIT DIAGRAM .....	119
FUEL SYSTEM REQUIREMENTS .....	120
REGULATIONS AND GUIDELINES .....	120
PORTABLE FUEL TANKS .....	120
FUEL FLOW REQUIREMENTS .....	120
FUEL REQUIREMENTS .....	121
COMPONENTS .....	122
FUEL LIFT PUMP .....	122
FUEL FILTER .....	122
VAPOR SEPARATOR .....	122
FUEL CIRCULATION PUMP .....	123
FUEL MANIFOLD .....	124
FUEL INJECTORS .....	124
FUEL SYSTEM PRIMING .....	125
VENT LINE CLAMP .....	125
PRIMING THE FUEL SYSTEM .....	125
FUEL SYSTEM TESTS .....	126
FUEL SYSTEM PRESSURE TEST .....	126
VAPOR SEPARATOR VENT CHECK .....	127
FUEL INJECTOR PRESSURE TEST .....	127
FUEL INJECTOR RESISTANCE TEST .....	127
CIRCULATION PUMP RESISTANCE TEST .....	128
LIFT PUMP PRESSURE TEST .....	128
LIFT PUMP VACUUM TEST .....	129
LIFT PUMP DIAPHRAGM TEST .....	129
ANTI-SIPHON VALVE TEST .....	130
FUEL COMPONENT SERVICING .....	130
RELIEVING FUEL SYSTEM PRESSURE .....	130
FUEL FILTER SERVICE .....	131
FUEL LIFT PUMP SERVICE .....	132
VAPOR SEPARATOR AND FUEL INJECTOR SERVICE .....	132
INTAKE MANIFOLD SERVICE .....	138



# SERVICE CHART

## INJECTORS, VAPOR SEPARATOR, FUEL PUMP

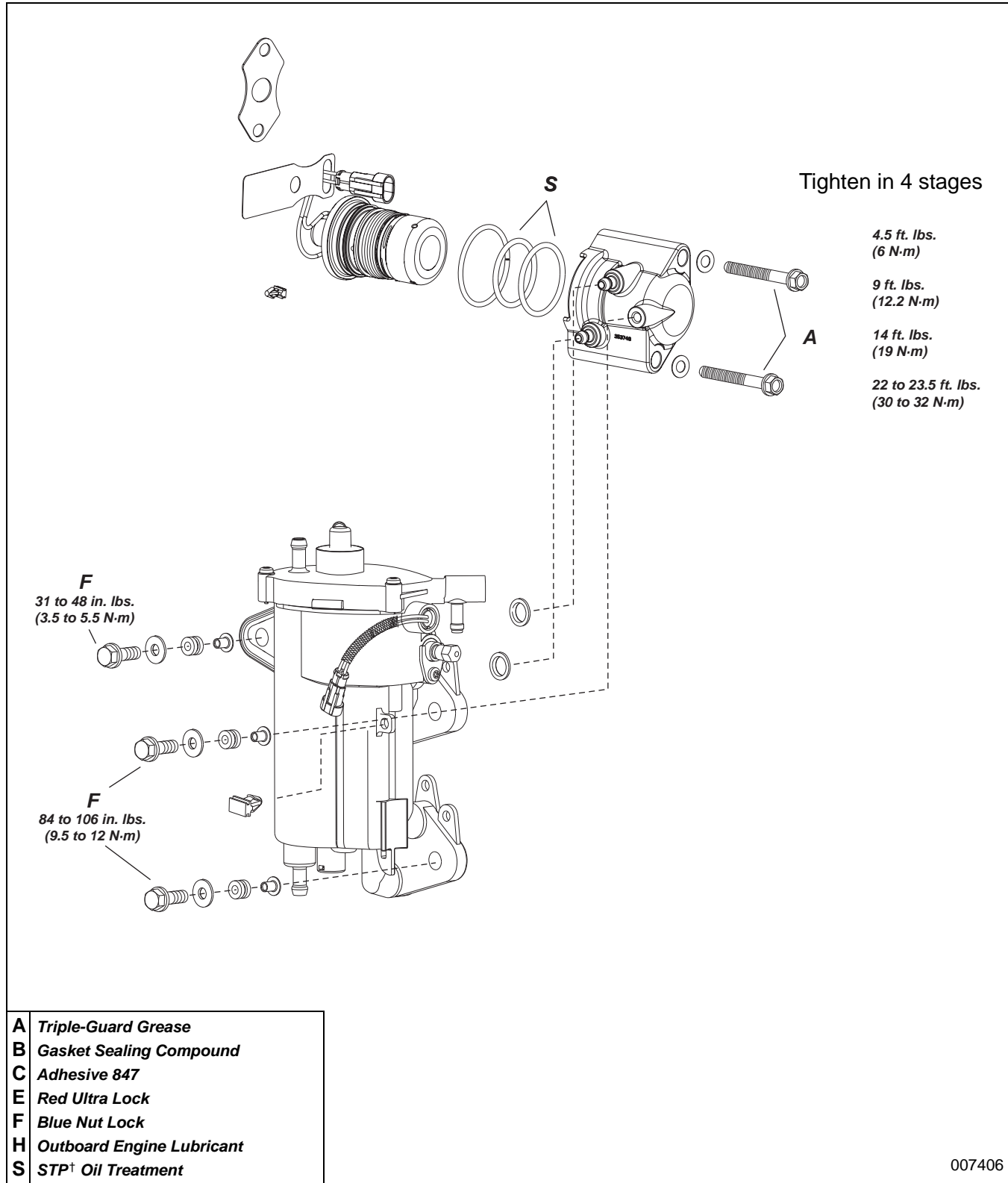

007406

**REED PLATE ASSEMBLY AND THROTTLE BODY**

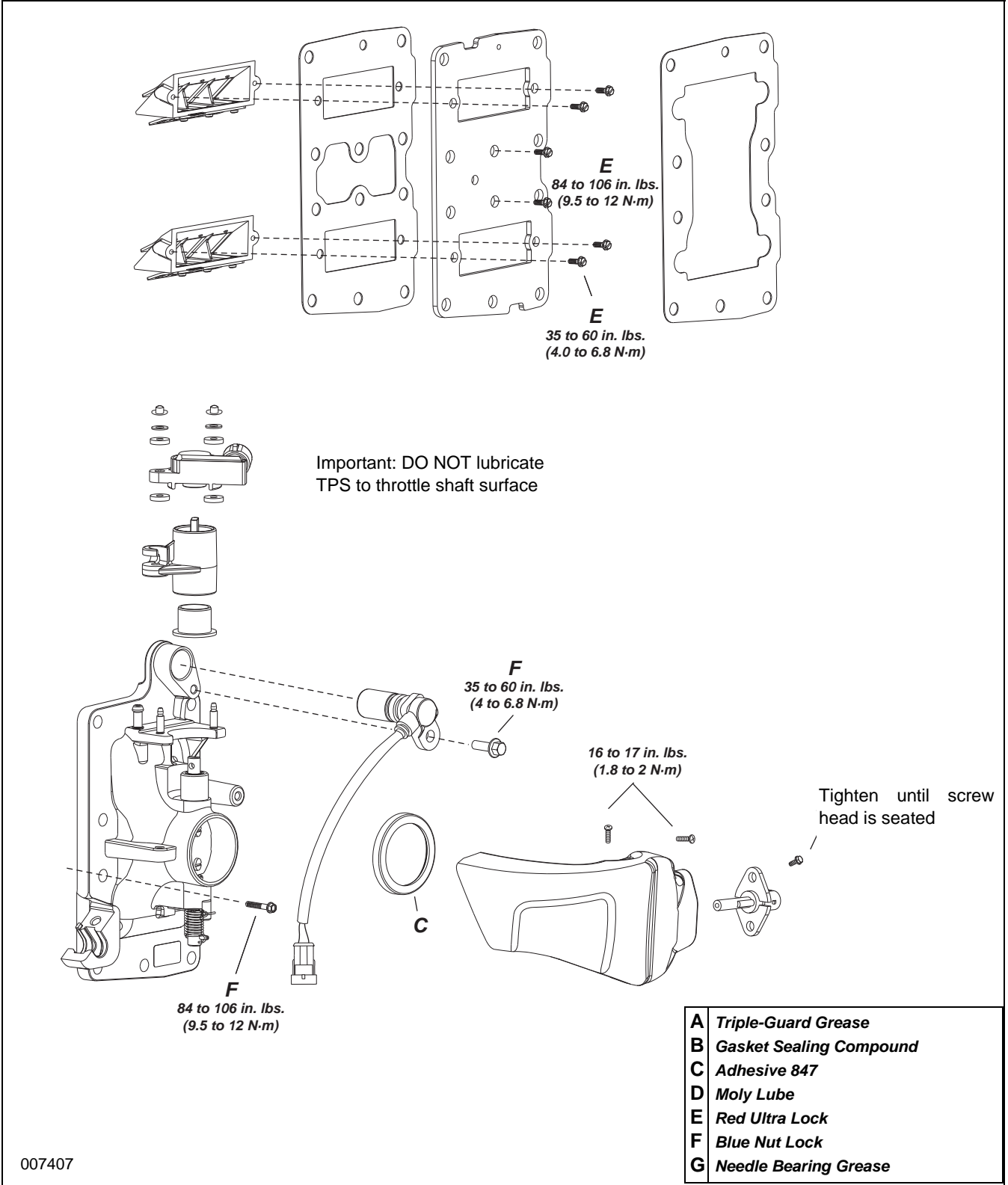

007407

## FUEL SYSTEM HOSE ROUTING

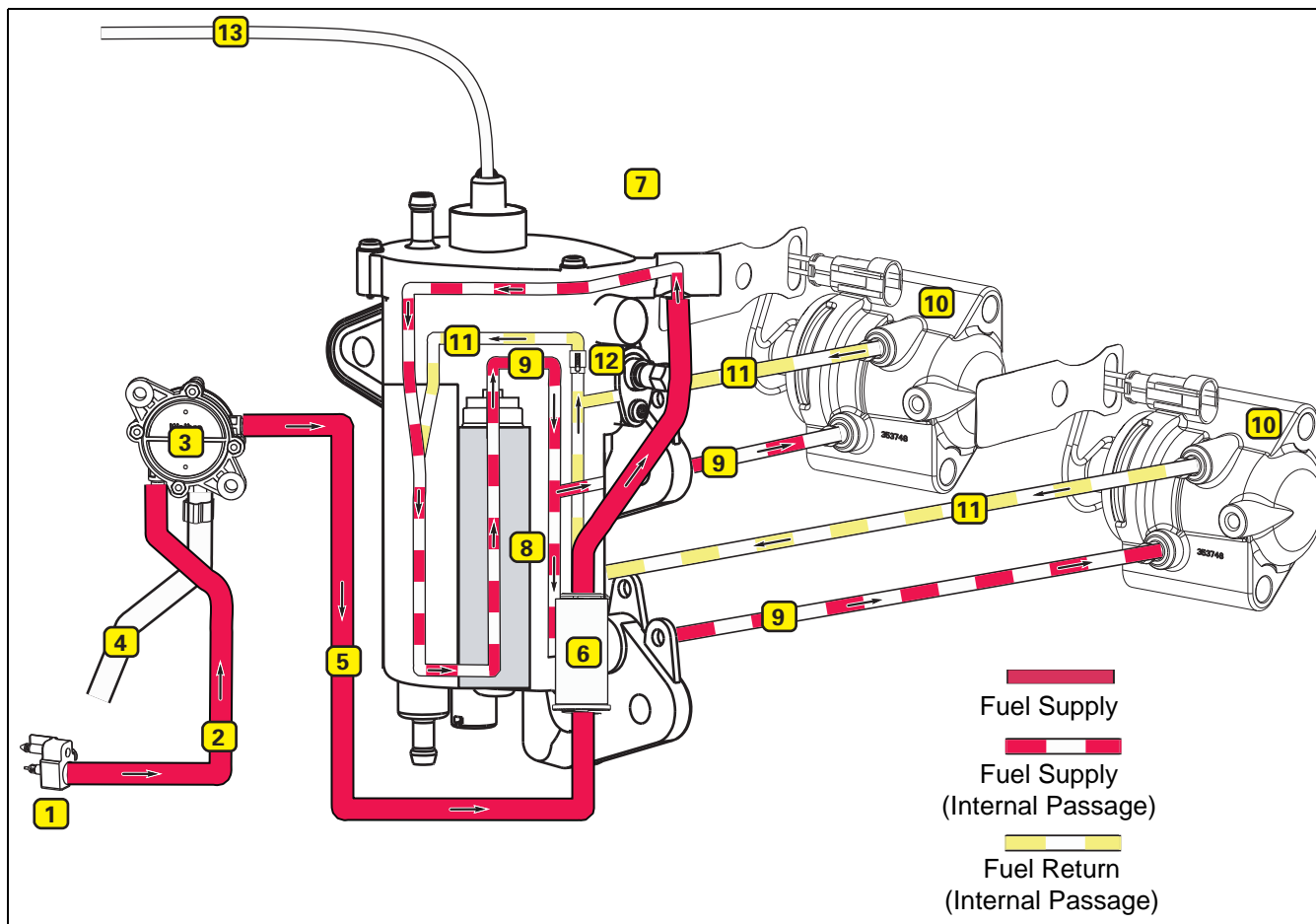

007408

1. Fuel fitting on outboard
2. Fuel supply from boat fuel system
3. Fuel lift pump (2 to 8 psi)
4. Pulse hose from cylinder/crankcase
5. Fuel supply to vapor separator
6. Fuel filter
7. Vapor separator
8. Electric fuel circulation pump (20 to 30 psi)
9. Fuel supply to injectors (internal passage)
10. Fuel injector(s)
11. Fuel return to vapor separator (internal passage)
12. Pressure regulator (high pressure)
13. Vent hose to intake manifold



# FUEL SYSTEM CIRCUIT DIAGRAM

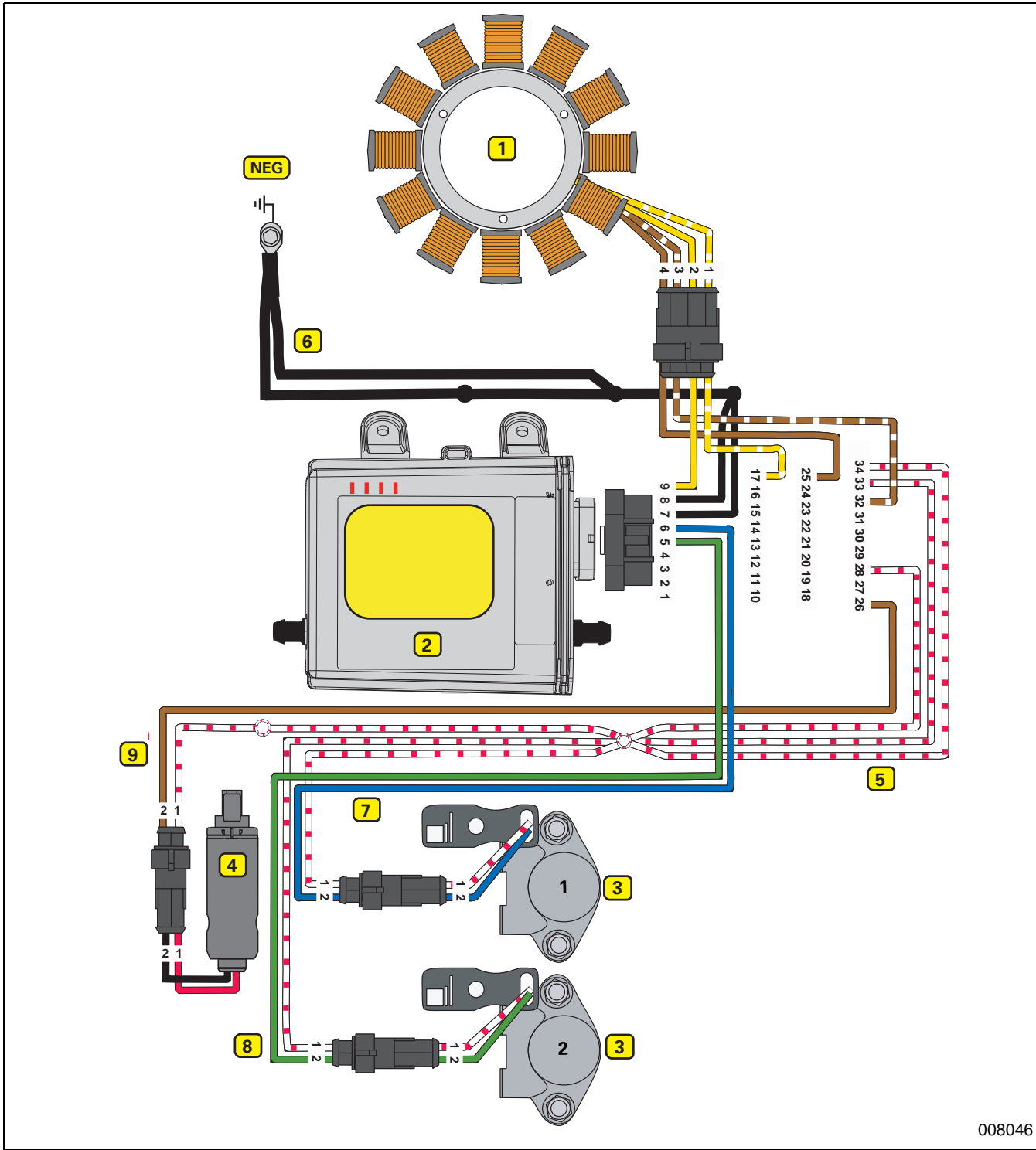

008046

- 1. Stator
- 2. EMM
- 3. Fuel injector

- 4. Fuel circulation pump
- 5. WHITE/RED (55 V)
- 6. BLACK ground wires

- 7. BLUE
- 8. GREEN
- 9. BROWN

# FUEL SYSTEM REQUIREMENTS

## Regulations and Guidelines

Vessel manufacturer, and/or installer of an EPA certified outboard, must meet minimum specifications for boat fuel systems established by:

- U.S. Environmental Protection Agency (EPA)
  - 40 CFR 1045.112
  - 40 CFR 1060
- U.S. Coast Guard (USCG)
  - 33 CFR 183
- American Boat & Yacht Council (ABYC)
  - Standard H-24
  - Standard H-25.

## Portable Fuel Tanks

**⚠ WARNING**

If engine is equipped with a quick-disconnect fuel hose, you **MUST** disconnect the fuel hose from the engine and the fuel tank to prevent fuel leaks:

- Whenever the engine is **NOT** being used
- Whenever the engine is being trailered
- Whenever the engine is in storage.

**NOTE:** A small amount of fuel may be released when the fuel connector is disconnected.

Store portable fuel tanks in well-ventilated areas, away from heat sources and open flames. Close the vent screw of the fuel tank cap, if equipped, to prevent escape of fuel or fuel vapors which could accidentally ignite. Do not allow disconnected fuel hoses to leak fuel.

**NOTICE** Do not use portable fuel tanks for outboards larger than 115 HP. Inadequate fuel flow to high horsepower outboards can result in serious powerhead damage.

## Fuel Flow Requirements

	15 – 30 HP	40 – 90 HP	115 – 300 HP
Fuel tank pickup tube	1/4 in. (6.4 mm) min. ID	5/16 in. (7.9 mm) min. ID	3/8 in. (9.5 mm) min. ID
Fuel fittings	5/32 in. (4.1 mm) min. ID	1/4 in. (6.4 mm) min. ID	9/32 in. (7.1 mm) min. ID
Fuel supply hoses	1/4 in. (6.4 mm) min. ID	3/8 in. (9.5 mm) min. ID	3/8 in. (9.5 mm) min. ID
<b>ALL MODELS</b>			
Fuel tank pickup screen	100 mesh, 304 grade stainless steel wire, 0.0045 in. wire diameter, 1 in. (25 mm) long		
Antisiphon valve	2.5 in. (63.5 mm) Hg maximum pressure drop at 20 gph (76 l/hr) flow		
Remote fuel filter	0.4 in. Hg maximum pressure drop at 20 gph (76 l/hr) flow, 150 in. <sup>2</sup> (1290 cm <sup>2</sup> ) of filter area		
Maximum fuel pump lift height	Fuel pump should not be located more than 30 in. (76.2 cm) above bottom of fuel tank		

## Fuel Requirements

### WARNING

**Gasoline is extremely flammable and highly explosive under certain conditions. Improper handling of fuel could result in property damage, serious injury or death.**

**Always turn off the outboard before fueling.**

**Never permit anyone other than an adult to refill the fuel tank.**

**Do not fill the fuel tank all the way to the top or fuel may overflow when it expands due to heating by the sun.**

**Remove portable fuel tanks from the boat before fueling.**

**Always wipe off any fuel spillage.**

**Do not smoke, allow open flames or sparks, or use electrical devices such as cellular phones in the vicinity of a fuel leak or while fueling.**

### Minimum Octane

*Evinrude/Johnson* outboards are certified to operate on unleaded automotive gasoline with an octane rating equal to or higher than:

- 87 (R+M)/2 AKI, or
- 90 RON

Use unleaded gasoline that contains methyl tertiary butyl ether (MTBE) **ONLY** if the MTBE content does not exceed 15% by volume.

Use alcohol-extended fuels **ONLY** if the alcohol content does not exceed:

- 10% ethanol by volume
- 5% methanol with 5% cosolvents by volume

When using alcohol-extended fuels, be aware of the following:

- The boat's fuel system may have different requirements regarding the use of alcohol fuels. Refer to the boat's owner guide.
- Alcohol attracts and holds moisture that can cause corrosion of metallic parts in the fuel system.
- Alcohol blended fuel can cause engine performance problems.
- All parts of the fuel system should be inspected frequently and replaced if signs of deterioration or fuel leakage are found. Inspect at least annually.

**IMPORTANT:** Always use fresh gasoline. Gasoline will oxidize, resulting in loss of octane and volatile compounds, as well as the production of gum and varnish deposits which can damage the outboard.

### Additives

**IMPORTANT:** The only fuel additives approved for use in *Evinrude* outboards are 2+4<sup>®</sup> fuel conditioner and *Evinrude/Johnson* Fuel System Cleaner. **Use of other fuel additives can result in poor performance or engine damage.**

***Evinrude/Johnson* 2+4 Fuel Conditioner** will help prevent gum and varnish deposits from forming in fuel system components and will remove moisture from the fuel system. It can be used continuously and should be used during any period when the outboard is not being operated on a regular basis. Its use will reduce spark plug fouling, fuel system icing, and fuel system component deterioration.

***Evinrude/Johnson* Fuel System Cleaner** will help keep fuel injectors in optimal operating condition.

## FUEL SYSTEM COMPONENTS

# COMPONENTS

The fuel system includes the following components:

- Fuel Lift Pump
- Fuel Filter
- Vapor Separator
- Fuel Circulation Pump
- Fuel Injectors

## Fuel Lift Pump

The fuel lift pump is a mechanical, pressure-pulse pump. The diaphragm of the pump is driven by a pulse hose that connects to the cylinder/crankcase assembly.

Fuel lift pump pulse hose location:

- Number 2 cylinder

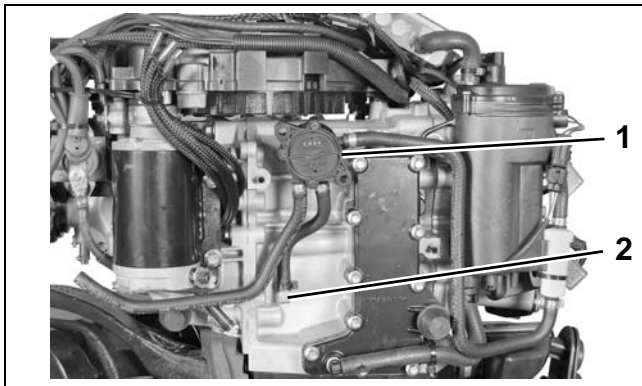

1. Fuel lift pump  
2. Pulse hose fitting

007410

Vacuum from the fuel lift pump pulls fuel from the fuel tank. Once fuel reaches the pump, internal pump pressure forces the fuel from the pump through the fuel filter and into the vapor separator.

## Fuel Filter

The fuel filter protects the vapor separator and the high-pressure components of the fuel system from contaminants. Refer to **INSPECTION AND MAINTENANCE SCHEDULE** on p. 14 for service frequency.

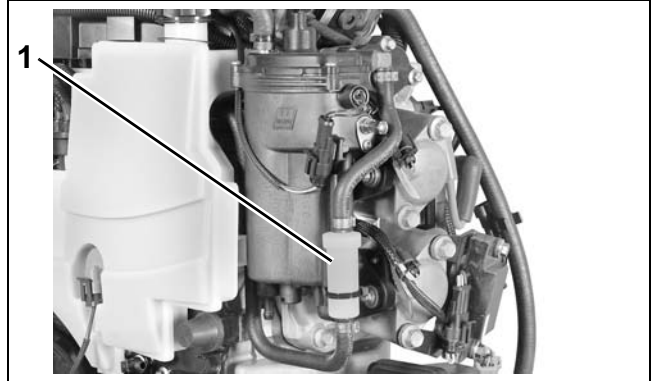

1. Filter

007273

## Vapor Separator

The vapor separator:

- Serves as a water-cooled fuel reservoir to accumulate incoming fuel from the fuel lift pump and from the fuel return.
- Contains a float controlling the venting of fuel vapors.
- Contains a fuel pressure regulator for the high pressure fuel system.

The vapor separator is serviced as an assembly and includes the fuel circulation pump.

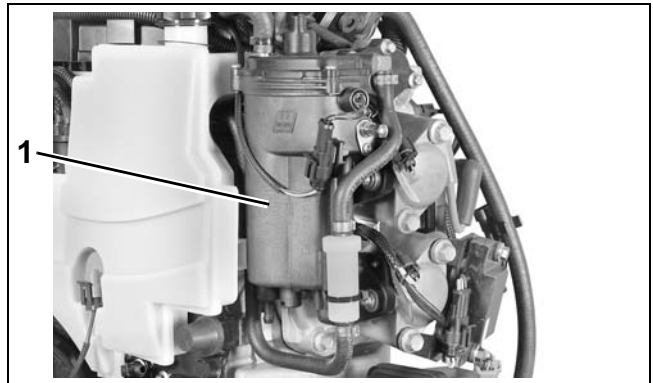

1. Vapor separator assembly

007273

**Fuel Reservoir**

The vapor separator accumulates fuel in an internal fuel reservoir and supplies fuel to the electric circulation pump. It is water-cooled to enhance vapor separating capabilities.

**Cooling**

Water is used to cool the fuel as it flows through the vapor separator. The cooling passage of the separator self-drains when the outboard is stored vertically. Refer to **HOSE ROUTING AND WATER FLOW DIAGRAMS** on p. 158.

**Venting**

The fuel vapor vent regulates fuel vapor pressure in the reservoir.



1. Vent

007411

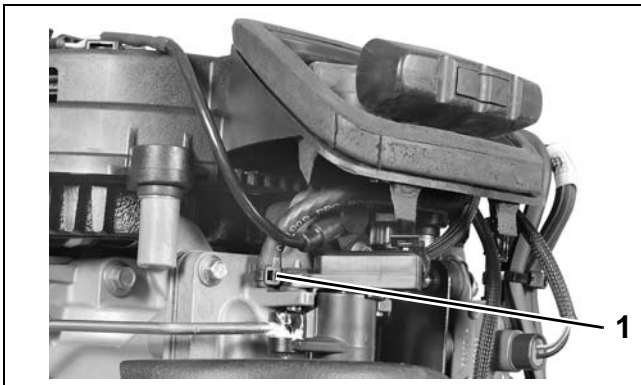

1. Vent hose connection to intake

007412

The vapor separator vent is opened and closed by a float valve. The float valve moves with the fuel level in the fuel chamber. Hot fuel causes an increase in vapor pressure. This results in a lower fuel level in the vapor separator. The float valve drops and the vent opens. This allows fuel vapor

to flow to the intake manifold through the vent hose.

As the vapor pressure in the vapor separator decreases, the fuel level begins to increase. An increase in the fuel level raises the float valve and the vent closes.

**Pressure Regulator**

The fuel pressure regulator helps maintain consistent fuel pressure in the fuel system.

Fuel returning from the injectors enters the fuel chamber of the vapor separator through a pressure regulator. The pressure regulator maintains approximately 28 to 32 psi (193 to 220 kPa) of fuel pressure in the high pressure side of the fuel system.

**Fuel Circulation Pump**

The fuel circulation pump is an electric high pressure fuel pump.

**Fuel Supply**

The pump is mounted in the vapor separator and draws fuel from the fuel chamber. It pumps pressurized fuel through an internal fuel supply passage connected to the fuel injectors.

**Electrical Circuit**

The circulation pump is controlled by the *EMM* and operates on the 55 V circuit. The outboard must be cranking or running (*CPS* input to *EMM*) for the circulation pump to be activated. The *EMM* controls pump operation by rapidly connecting and disconnecting the pump's internal coil to ground.

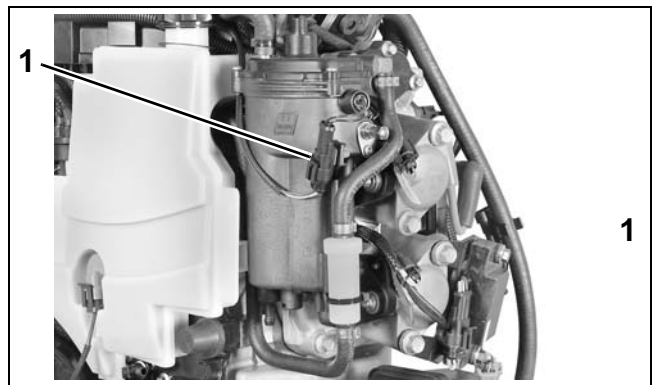

1. Fuel pump electrical connector

007273

---

## FUEL SYSTEM COMPONENTS

---

### Fuel Manifold

The vapor separator uses molded internal passages to route fuel directly to and from the injectors. Refer to **FUEL SYSTEM HOSE ROUTING** on p. 118.

### Fuel Injectors

Fuel injectors are fuel metering, electric solenoids (55 V) bolted directly to the cylinder head. The *EMM* controls the activation of each injector by rapidly connecting and disconnecting the injector's internal coil to ground.

### Fuel Flow Compensation

The flow rate of each injector is measured as part of the manufacturing process. This information is recorded and assigned to the injector by serial number.

The *EMM* is programmed to compensate for variations in fuel flow. Each injector and its location on the outboard is identified by the *EMM*. **DO NOT** install an injector without updating the compensation software.

Each service injector includes its fuel flow information on a 3.5 in. floppy disk. This software allows the *EMM* to be reprogrammed for this injector's unique fuel flow characteristics.

**NOTICE** Fuel injectors **MUST NOT** be moved from one cylinder to another. *EMM* programming is associated with the cylinder location of each injector. Installing an injector on the wrong cylinder can result in powerhead failure.

### Injector Fuel Supply

Fuel is supplied to the injectors by the fuel circulation pump and the fuel supply manifold.

Each injector has internal fuel passages. These passages are designed to:

- Provide fuel to the injector's injection chamber
- Route fuel through the injector housing to cool the injector coil and armature

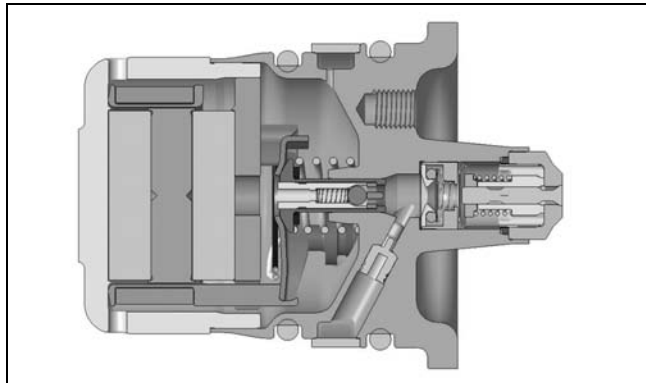

006619

## FUEL SYSTEM PRIMING

### Vent Line Clamp

Federal Regulations require that all outboards with a fuel vapor separator must be shipped with a vent line clamp installed. This clamp must be removed before priming the fuel system or starting the outboard for the first time.



007131

**IMPORTANT:** Failure to remove the clamp may cause fuel starvation and poor running qualities.

### Priming the Fuel System

#### **⚠ WARNING**

**Fuel vapors are highly flammable. Perform the following procedure in a well ventilated area. Extinguish all smoking materials and make certain no ignition sources are present.**

Connect the fuel hose connector to the quick connect fitting on the outboard.

Use the primer to fill the vapor separator.

The high-pressure fuel circuits and injectors will prime as the outboard is cranked with the starter.

Observe all fuel lines, both in the boat and on the outboard. Repair any fuel leaks.

#### **⚠ WARNING**

**Failure to check for fuel leaks could allow a leak to go undetected, resulting in fire or explosion and may cause personal injury or property damage.**

## FUEL SYSTEM TESTS

### ⚠ WARNING

Use caution when working on any pressurized fuel system. Wear safety glasses and work in a well ventilated area. Extinguish all smoking materials and make certain no open flames or ignition sources exist. Before starting any fuel system service, carefully relieve fuel system pressure. Failure to properly relieve fuel system pressure can result in spraying fuel and/or excessive fuel spillage during servicing. Fuel is flammable and can be explosive under certain conditions.

### Fuel System Pressure Test

Relieve fuel system pressure. Refer to **Relieving Fuel System Pressure** on p. 130.

### ⚠ WARNING

Protect against hazardous fuel spray. Before starting any fuel system service, carefully relieve fuel system pressure.

After relieving fuel system pressure, install a 0 to 60 psi (0 to 415 kPa) Fuel Pressure Gauge, P/N 5007100 or equivalent, to the fuel pressure test fitting.

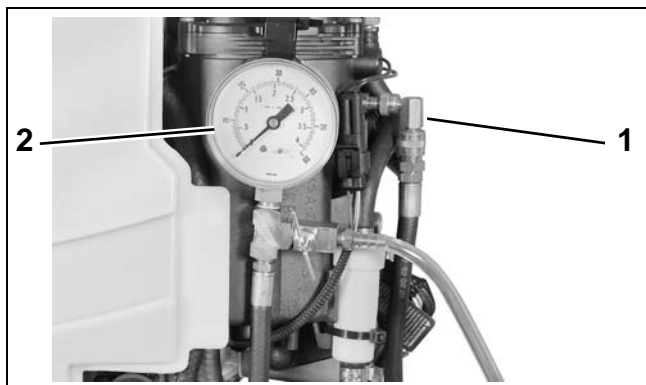

1. Test fitting  
2. Fuel pressure gauge

007413

START outboard and check pressure. System pressure should be 28 to 32 psi (193 to 220 kPa).

Shut OFF outboard. Monitor pressure gauge. Pressure should not drop below 15 psi (103 kPa).

**IMPORTANT:** If outboard does not run, prime fuel system and crank outboard; check circulation pump operation; check fuel system pressure.

#### Results:

Normal pressure:

- Observe pressure reading after outboard is shut OFF
- Refer to **Lift Pump Pressure Test** on p. 128

Pressure drops after outboard is shut OFF:

- Check for leaking fuel injector.
- Check for leaking pressure regulator.
- Check for external fuel system leak.

High pressure:

- Replace vapor separator.

Low pressure:

- Check fuel supply to fuel lift pump. Refer to **Lift Pump Vacuum Test** on p. 129. Higher vacuum readings indicate restrictions in the fuel supply. Repair or replace as needed.
- Restricted fuel filter/water separator assembly.
- Lift pump not supplying enough fuel to vapor separator. Refer to **Lift Pump Pressure Test** on p. 128.
- If the above tests are good and vapor separator remains full of fuel, check for damaged circulation pump. Replace vapor separator assembly.

No pressure:

- Check electrical circuit and ground connections for circulation pump.
- If voltage is present and pump does not run, repair connection or replace vapor separator assembly.

Relieve fuel system pressure before removing fuel pressure gauge. Refer to **Relieving Fuel System Pressure** on p. 130.



## Vapor Separator Vent Check

Monitor the vapor separator vent hose. No fuel or a trace of fuel is acceptable. Excessive fuel discharge indicates a vapor separator vent malfunction. Monitor vent for presence of fuel during testing. Temporarily install clear tubing for monitoring. Replace vapor separator if the venting of fuel is continuous.

## Fuel Injector Pressure Test

Disconnect the battery cables at the battery.

Remove vapor separator assembly. Refer to **Vapor Separator Removal** on p. 132.

**IMPORTANT:** Perform test with injector mounted to cylinder head.

Seal injector outlet fitting with a cap, such as Plug, P/N 315391, and a tie strap.

Connect a 0 to 30 psi (0 to 207 kPa) pressure tester to the inlet fitting. Secure with tie strap.

Pressurize the injector to 30 psi (207 kPa). Pressure must hold for at least five minutes.

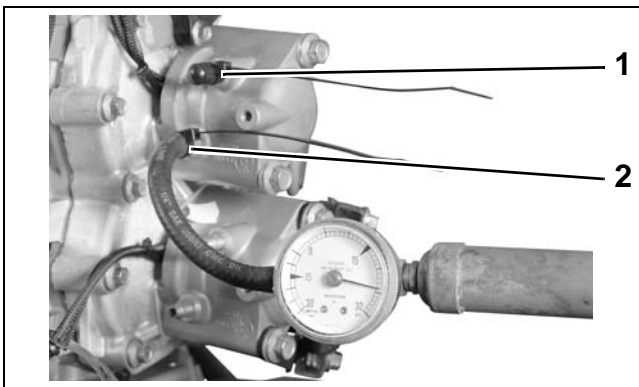

1. Outlet fitting
2. Inlet fitting

007414

Refer to **FUEL DELIVERY TESTS** on p. 78 for additional test procedures.

## Fuel Injector Resistance Test

Disconnect the battery cables at the battery.

Use a digital multimeter to measure the injector coil resistance.

Fuel Injector Coil Resistance
2 to 3 $\Omega$ @ 72°F (22°C)

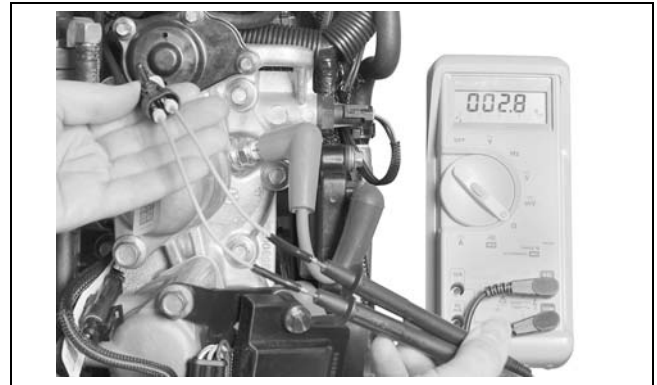

007415

Use a digital multimeter with appropriate adapter leads to measure resistance of the complete injector circuit, including injector and associated wiring.

Measure resistance between pin 1 (white/red) of injector connector (connected) and the appropriate pin location of *EMM* J1-B connector (disconnected). Refer to engine wiring diagram for specific *EMM* J1-B connector pin location for the injector circuit being tested (blue or green).

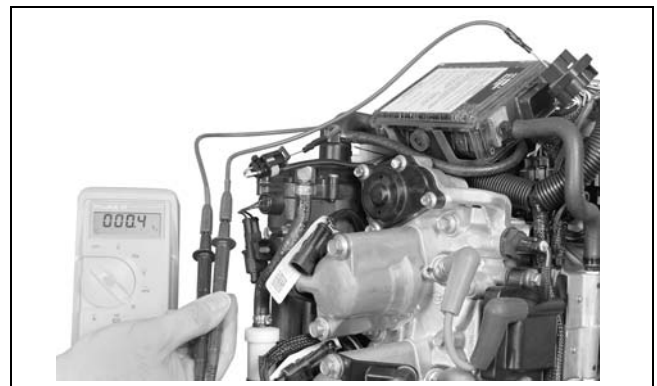

007416

Resistance should be the same as, or slightly higher than, the injector alone.

## FUEL SYSTEM

### FUEL SYSTEM TESTS

#### Circulation Pump Resistance Test

Disconnect the battery cables at the battery.

Use a digital multimeter with appropriate adapter leads to measure the fuel pump circuit and coil resistance.

<b>Fuel Pump Resistance</b>
2 to 8 $\Omega$ @ 77°F (25°C)

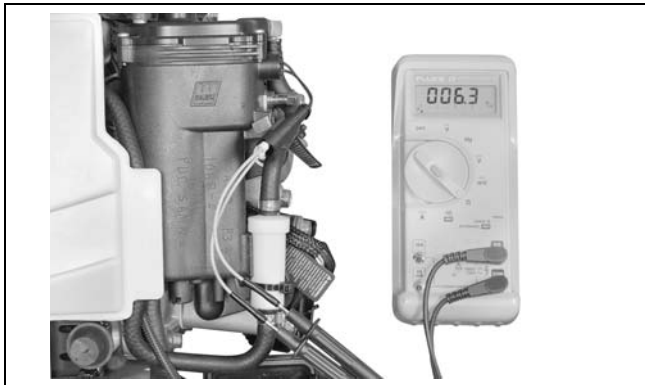

007417

#### Lift Pump Pressure Test

Install a 0 to 15 psi (0 to 103 kPa) Fuel Pressure Gauge. Tee into the fuel supply line before the fuel filter.

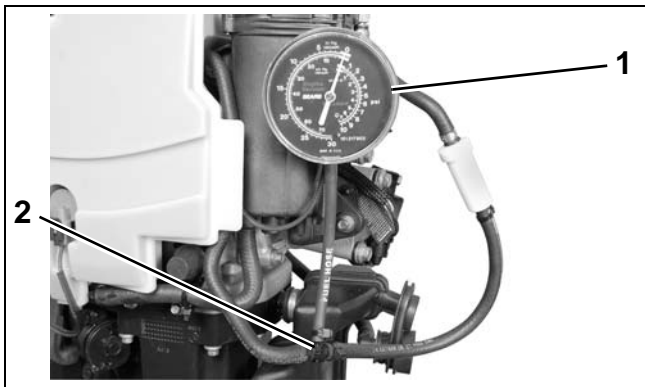

1. Fuel pressure gauge
2. Tee fitting

007418

Prime the fuel system and check for leaks. START outboard and run at idle speed. Hold gauge level with inlet fitting and monitor gauge for pressure reading.

Pressure should stabilize at a reading greater than 2 psi (14 kPa).

#### Results:

Normal pressure:

- Perform the **Lift Pump Vacuum Test** on p. 129. Make sure no air leaks or restrictions exist in the fuel supply hose or boat fuel system.

Low pressure:

- Check pulse hoses and fittings for restrictions.
- Perform the **Lift Pump Vacuum Test** on p. 129. Make sure no air leaks or restrictions exist in the fuel supply hose or boat fuel system.
- Check fuel flow through fuel lift pump. Use fuel primer bulb to force fuel through pump.

No pressure:

- Check pulse hoses and fittings restrictions.
- Check fuel flow through fuel lift pump. Use fuel primer or primer bulb to force fuel through pump.
- Momentarily prime or squeeze primer bulb to check gauge operation.
- Check pulse hose and fittings for restrictions.

## Lift Pump Vacuum Test

Confirm fuel supply to the fuel lift pump.

Temporarily install a vacuum gauge, T-fitting, and 8 in. (20.3 cm) of clear vinyl hose between the fuel supply hose and fuel lift pump (inlet). Secure connections with tie straps to prevent fuel or air leaks.

**NOTICE** Do not use fuel primer bulb, manual fuel primer, or electric fuel pump primer to restart outboard. A positive pressure in the fuel supply could damage some vacuum gauges.



007419

START outboard and run at FULL THROTTLE for at least two minutes. Monitor clear vinyl hose for the presence of air. Air bubbles indicate a faulty hose, connection, or fuel tank pick-up. Repair, if necessary, before proceeding.

There should be no air or vapor bubbles visible in the clear hose. The maximum inlet fuel vacuum should not exceed 4 in. Hg. (13.5 kPa) at the inlet to the fuel lift pump under any operating conditions (IDLE to WOT).

A higher vacuum indicates an excessive restriction in the fuel supply. Repair as needed. Refer to **FUEL SYSTEM REQUIREMENTS** on p. 120 for fuel supply component requirements.

## Lift Pump Diaphragm Test

Perform this test only if a damaged pump is suspected. This test does not confirm the performance of the internal fuel pump check valves.

Remove the fuel inlet and outlet hoses from the fuel pump housing.

Attach gearcase pressure tester to the fuel outlet. Apply 3 psi (20 kPa). Replace lift pump if pump fails to hold pressure.

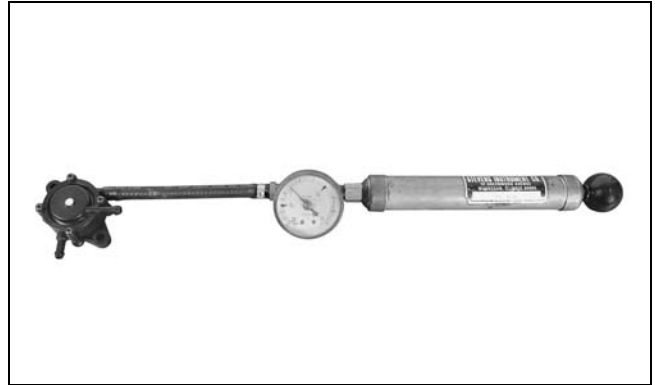

007420

Attach gearcase vacuum tester to the fuel inlet. Apply 3 in. Hg. (-10 kPa). Replace lift pump if pump fails to hold vacuum.

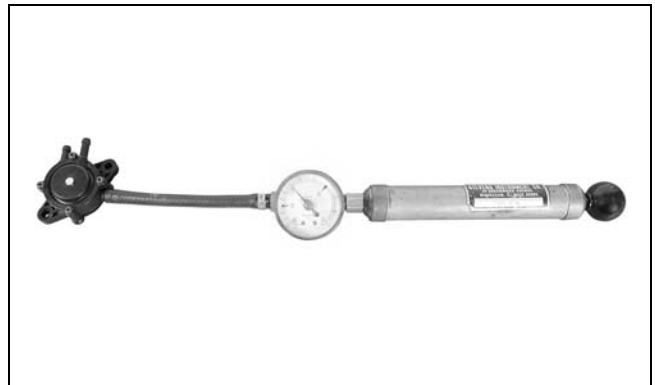

007421

## Anti-Siphon Valve Test

Remove anti-siphon valve from fuel tank. Install adapter fittings and a 36 in. (91.4 cm) length of clear hose to the inlet side (tank end) of valve.

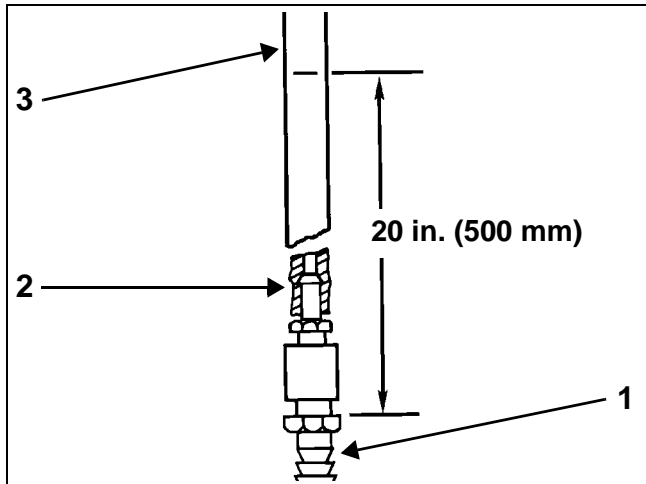

1. Anti-siphon valve
2. Adapter fitting
3. Clear hose

DR2277

Fill clear hose with water to a height of 20 in. (500 mm). Water must NOT flow through valve. An occasional drip is acceptable. Replace valve if water drips continuously.

Increase height of water to 25 in. (630 mm). Water should flow through valve as water level reaches 25 in. (630 mm). Replace the anti-siphon valve if test results are different.

## FUEL COMPONENT SERVICING

### **⚠ WARNING**

Gasoline is extremely flammable and highly explosive under certain conditions. Use caution when working on any part of the fuel system.

Protect against hazardous fuel spray. Before starting any fuel system service, carefully relieve fuel system pressure. Refer to Relieving Fuel System Pressure.

Always disconnect the battery cables at the battery before servicing the fuel system unless instructed to do otherwise.

Always work in a well ventilated area and wipe off any fuel spillage.

**DO NOT** smoke and make certain no open flames or ignition sources exist.

After servicing the fuel system check for leaks. Failure to check for fuel leakage could allow a leak to go undetected, resulting in fire or explosion.

## Relieving Fuel System Pressure

**IMPORTANT:** Minimize fuel system pressure before disassembly. Disconnect the fuel supply hose from outboard. Remove propeller and disconnect circulation fuel pump electrical connector. If outboard runs, start and run at IDLE for 5 seconds and STOP outboard. If outboard does NOT run, crank for 10 seconds.

Disconnect the battery cables at the battery.

Wrap a shop towel completely around the pressure test valve while connecting fitting from Fuel Pressure Gauge, P/N 5007100, to test fitting of fuel pump/vapor separator assembly.

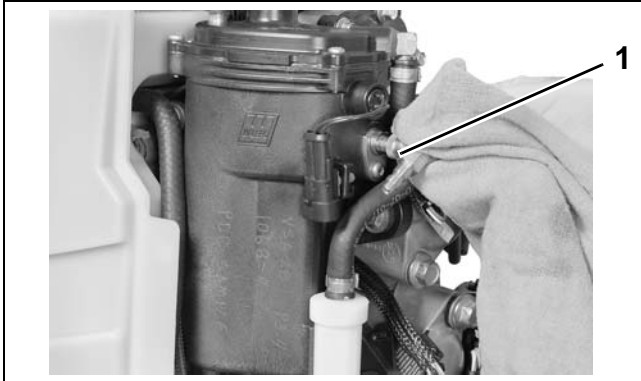

1. Test fitting

007096

Insert venting hose of gauge into a suitable container.

Slowly open gauge's venting valve.

Clean up any spilled fuel with shop towels.

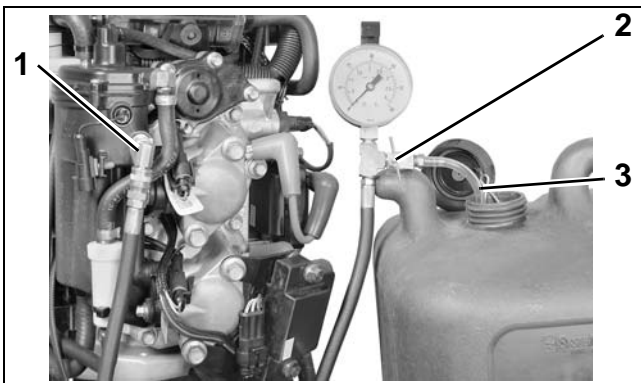

1. Test fitting
2. Venting valve
3. Venting hose

007097

## Fuel Filter Service

### Removal

Disconnect the battery cables at the battery.

Remove filter carefully to prevent spilling contents.

Inspect contents for any presence of water. If water is present, identify the source and correct the problem. Take additional fuel samples and drain fuel tank(s) if necessary.

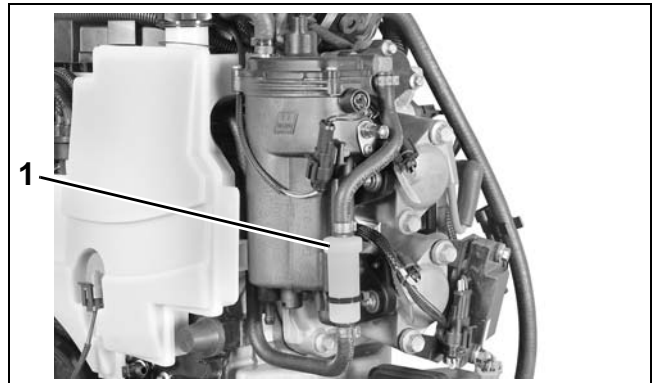

1. Fuel filter flange

007273

### Installation

Install filter in fuel supply hoses. Flanged part of filter is up. Secure filter with appropriate clamps.

Squeeze primer bulb to prime fuel system. Hold pressure on bulb and check for fuel leaks.

Connect battery cables.

Run outboard and check for fuel leaks.

## FUEL SYSTEM

### FUEL COMPONENT SERVICING

#### Fuel Lift Pump Service

The fuel lift pump is serviceable as a complete assembly. Refer to parts catalog for service parts.

#### Removal

Disconnect the battery cables at the battery.

Remove port lower motor cover. Refer to **Lower Cover Removal**.

Remove the oil tank. Refer to **Oil Tank Assembly** on p. 155.

Use an appropriate tool to remove the push nuts that retain fuel pump to oil tank.

Remove the fuel hoses from the fuel pump housing.

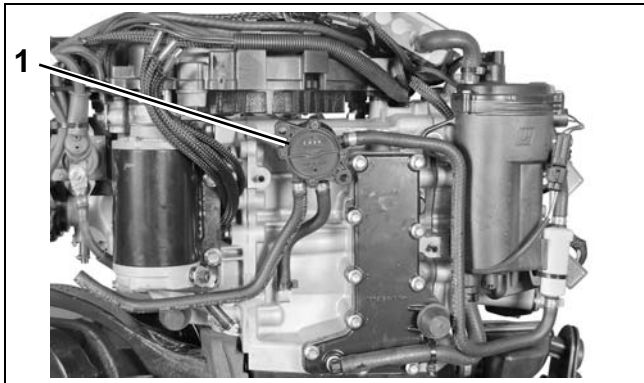

1. Fuel pump housing

007410

Remove the fuel lift pump.

#### Installation

Connect the fuel hoses to the fuel pump. Secure with *Oetiker* clamps.

Place fuel pump in position on the oil tank. Secure the fuel pump with new pushnuts, P/N 354365.

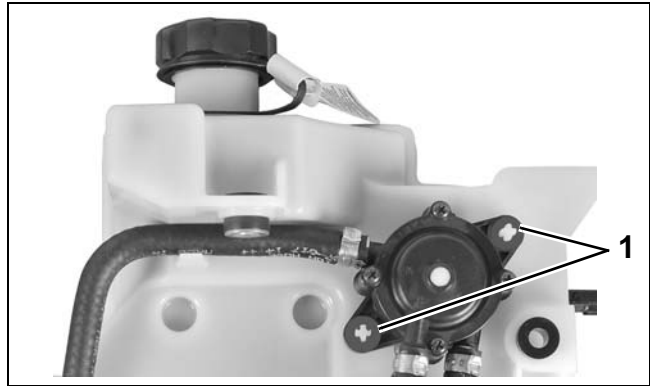

1. Push nuts

007422

Be sure fuel hoses are routed in channels on oil tank. Install the oil tank. Refer to **Oil Tank Assembly** on p. 155.

Squeeze primer bulb to prime fuel system. Hold pressure on bulb and check for fuel leaks.

Connect battery cables.

Run outboard and check for fuel leaks.

#### Vapor Separator and Fuel Injector Service

##### Vapor Separator Removal

Relieve fuel system pressure. Refer to **Relieving Fuel System Pressure** on p. 130.

Disconnect the battery cables at the battery.

Remove oil tank. Refer to **Oil Tank Assembly** on p. 155.

Disconnect vapor separator and fuel injector electrical connectors. Remove connectors from retainers.

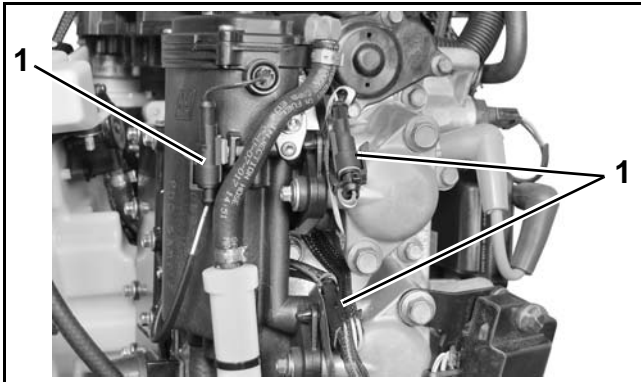

1. Electrical connectors

007423

Remove clamps and fuel supply hose, vapor separator vent hose and cooling water hoses.

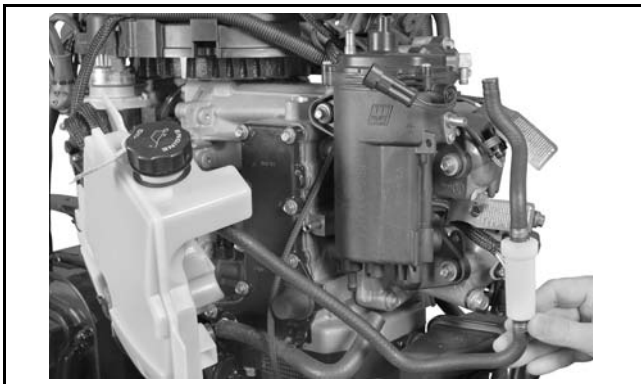

007285

Loosen four injector screws.

Remove three vapor separator retaining screws.

Remove vapor separator.

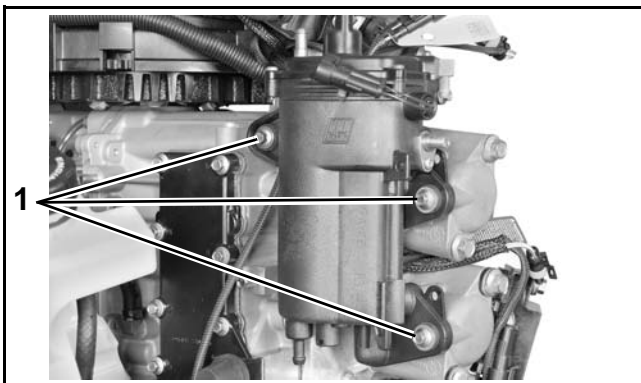

1. Retaining screws

007098

## Fuel Injector Removal

Mark fuel injectors to show cylinder locations.

**NOTICE** Fuel injectors must be installed in the correct cylinder locations. Use *Evinrude Diagnostics Software* to make sure that *EMM* programming matches injector positioning. The *Injector Coefficients* screen displays injector serial numbers for each cylinder.

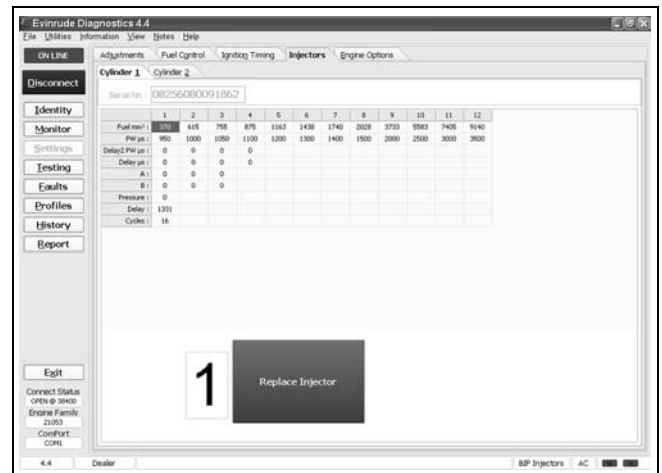

Injector Coefficients Screen

008137

Use caution when handling fuel injectors. Prevent dirt and debris from entering fuel inlet and outlet ports of injectors. Cover the injector nozzle port in cylinder head to prevent contamination of combustion chamber.

Remove injector screws.

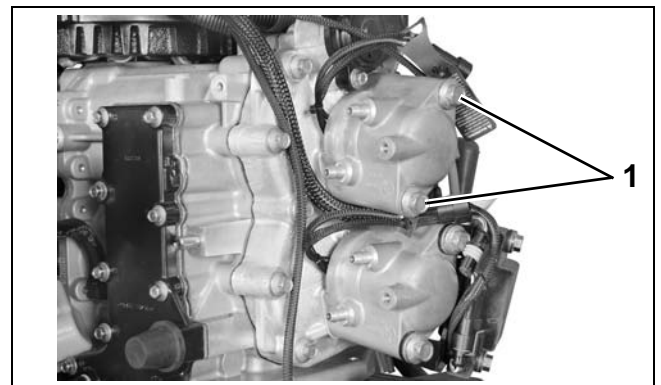

1. Injector screws

007100

Remove fuel injector and insulator.

# FUEL SYSTEM

## FUEL COMPONENT SERVICING

### Crush Ring Replacement

**NOTICE** Injector crush rings must be replaced if injector is installed in a different head or cylinder location.

Use Slide Hammer assembly, P/N 391008, with Slide Hammer Adaptor kit, P/N 390898, to remove injector from mounting cup.

Thread adaptor and stud into face of injector. Hold mounting cup securely. Use slide hammer to separate injector from mount housing.



002345

Remove adaptor from injector. Remove crush ring and O-rings from injector. Inspect and clean injector filter. Install new crush ring and O-rings. Lubricate O-rings with *STP<sup>+</sup> Oil Treatment*.



1. Adaptor

007424

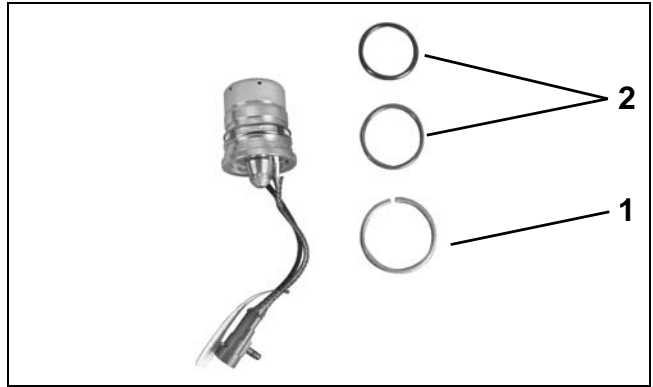

1. Crush ring  
2. O-rings

002317

Install injector into mount housing. Press on injector face until injector seats in mount housing.

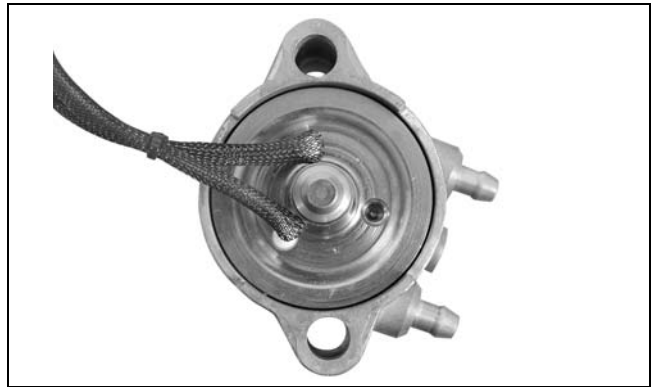

007425



## Fuel Injector Installation

**NOTICE** All injectors must be installed in the correct cylinder by serial number. Improper injector installation can result in powerhead failure.

Installation of a replacement injector requires that coefficient data for the new injector is uploaded to the *EMM*.

Coefficient data for some replacement injectors is supplied on a computer disk shipped with the injector. If a disk is not included with the injector, coefficient data can be downloaded from the *Evinrude/Johnson* dealer website. Refer to the instructions provided with the injector kit.

### Upload Coefficient Files to *EMM*

Use the *Evinrude Diagnostics* software *Settings* screen to upload the coefficient file to the *EMM*.

Select the *Injectors* tab.

Select the cylinder tab for injector being replaced.

Select the *Replace Injector* button.

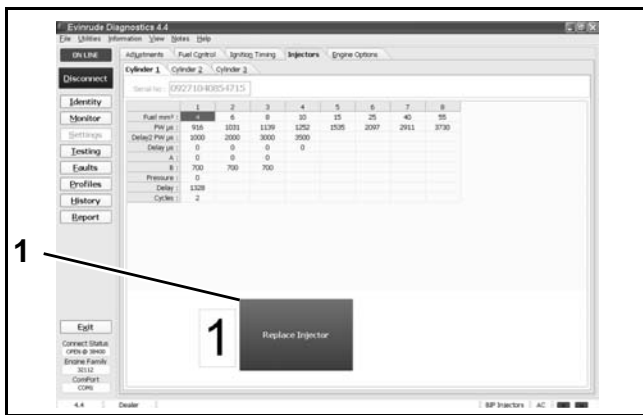

1. "Replace Injector" button

008079

Use the drop down menu to navigate to the saved coefficient file location.

The coefficient file name must match the serial number of the injector.

Select the correct file for the injector.

Select the *Replace Injector* button.

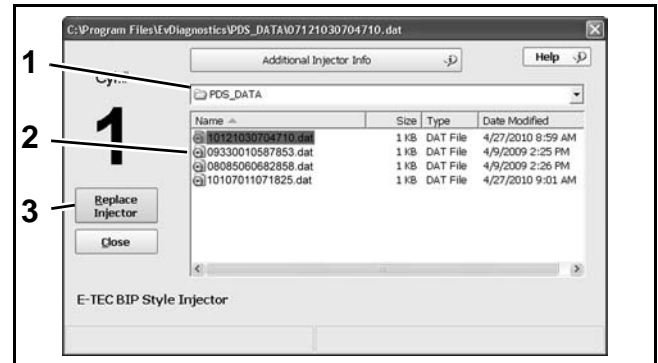

1. Navigation menu
2. Injector coefficient file
3. "Replace Injector" button

008335

After the upload is complete, the program will return to the *Cylinder* tab.

Make sure the serial number displayed on the screen matches the serial number printed on the serial number label of the replacement injector.

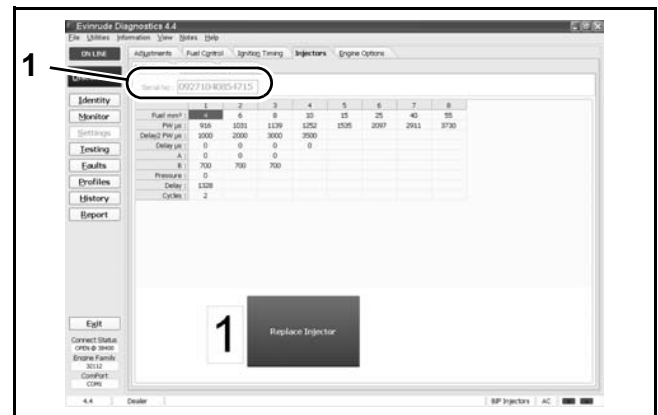

1. Serial number

008079



## FUEL SYSTEM

### FUEL COMPONENT SERVICING

#### Install Injector

The following items and their mating surfaces must be cleaned prior to reassembly:

- Injector
- Cylinder head
- Adapter
- Screws
- Threaded areas.

#### CAUTION

All injector components must be clean to ensure correct torque tightening specifications. To prevent fuel leakage, carefully follow these installation instructions.

Lubricate mounting screw threads and under the head of the screw with a light coat of *Triple-Guard* grease. Install washers (one per screw) on injector retaining screws.

Install screws and washers through mounting flange of injector. Lower cylinder screws go through the coil mounting bracket.

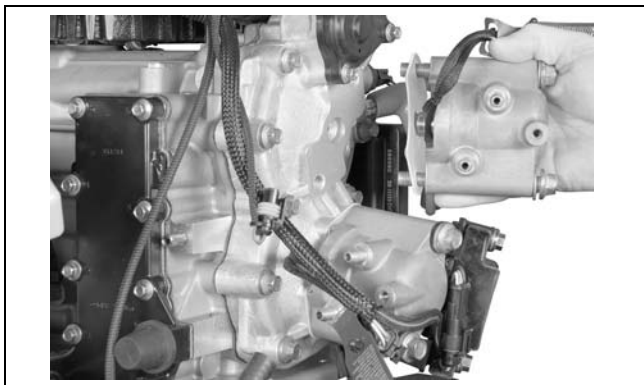

007286

**IMPORTANT:** Be careful not to pinch any wiring during assembly.

Place injector and insulator in the proper cylinder location.

Temporarily install injector screws finger tight.

Position fuel injector wiring, vapor separator wiring and electrical connectors as shown.

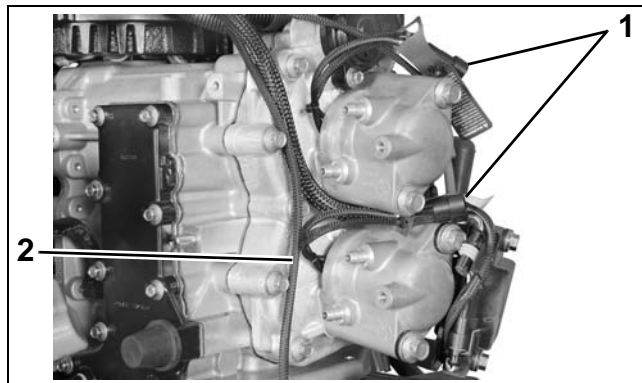

1. Fuel injector wiring and connectors
2. Vapor separator wiring

007100

**IMPORTANT:** Fuel injectors MUST be able to rotate slightly during installation of vapor separator.

#### Vapor Separator Installation

Install new injector seals in vapor separator.

Lightly lubricate seals with a drop of outboard lubricant.

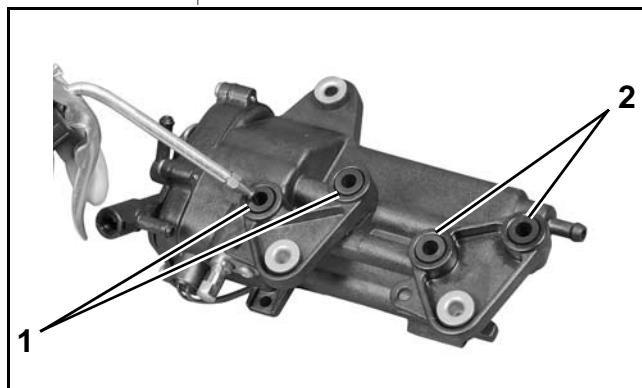

1. Injector seals

007099

Install vapor separator assembly onto the four fuel injector fittings.

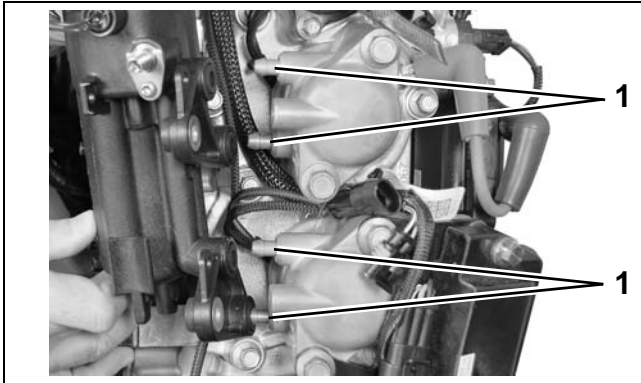

1. Fuel injector fittings

007101

Install three vapor separator retaining screws.

Tighten two vapor separator to fuel injector mounting screws to a torque of 29 to 48 in. lbs. (3.3 to 5.5 N·m).

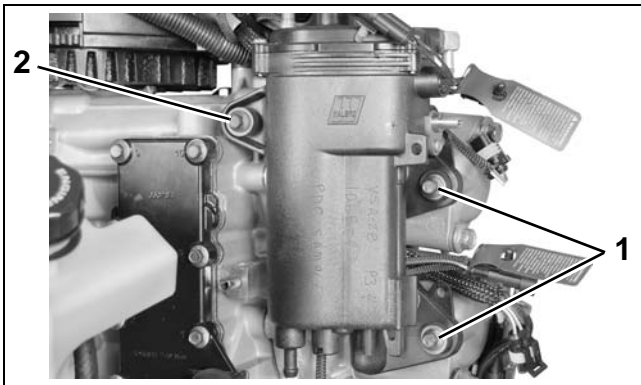

1. Vapor separator to fuel injector mounting screws  
 2. Vapor separator to powerhead mounting screw –  
 Leave LOOSE at this time

007102

**IMPORTANT:** Fuel injector screws must be tightened before vapor separator to powerhead mounting screw.

Tighten injector screws in stages, starting with the lower screw.

- First torque is 4.5 ft. lbs. (6 N·m).
- Second torque is 9 ft. lbs. (12.2 N·m).
- Third torque is 14 ft. lbs. (19 N·m).

- Final torque is 22 to 23.5 ft. lbs. (30 to 32 N·m).

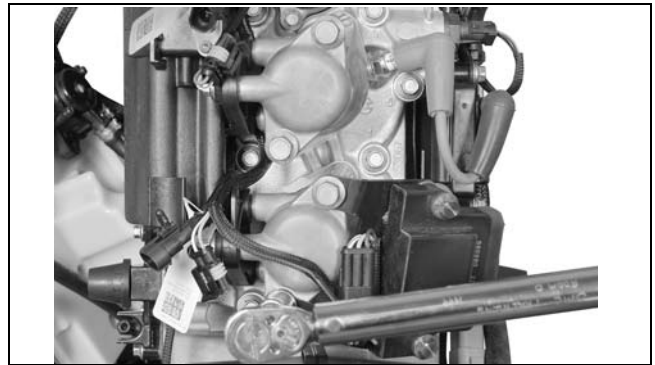

Tighten Screws in Stages

007103

Tighten vapor separator to powerhead mounting screw to 29 to 48 in. lbs (3.3 to 5.5 N·m).

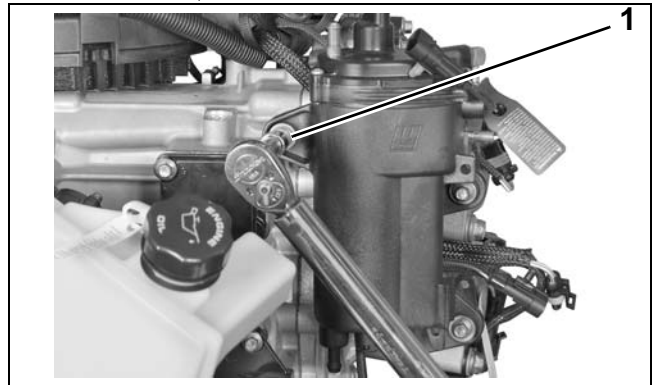

1. Vapor separator to powerhead mounting screw

007104

Install fuel supply hose. Secure with *Oetiker* clamps. Reinstall vapor separator vent hose and cooling water hoses. Secure with tie straps. Attach fuel filter to vapor separator with tie strap.



007287

Reinstall protective cap on the pressure test fitting. Reconnect fuel injector electrical connectors.

## FUEL SYSTEM

### FUEL COMPONENT SERVICING

Reconnect circulation fuel pump electrical connector.

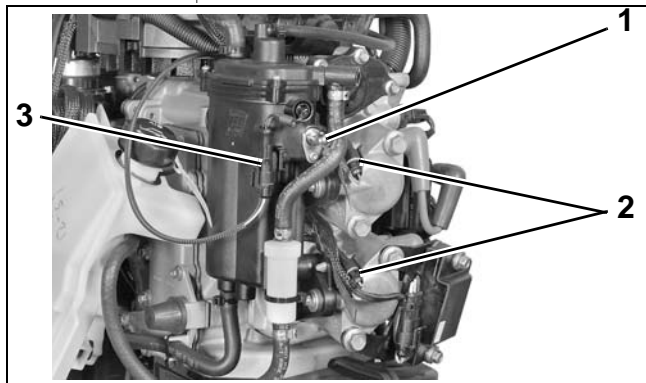

1. Protective cap
2. Fuel injector electrical connectors
3. Circulation fuel pump electrical connector

007105

Reinstall the oil tank. Refer to **Oil Tank Assembly** on p. 155.

Reconnect the battery cables at the battery.

Reconnect fuel hose connector to outboard.

**IMPORTANT:** Install injector service data (3.5 in. floppy disk) by using the Injector Replacement Utility of *Evinrude Diagnostics* software. Check the *Injector Coefficients* screen to make sure that all injectors are positioned properly.

Squeeze primer bulb to prime fuel system. Hold pressure on bulb and observe for fuel leaks.

Use static test screen of *Evinrude Diagnostics* software to run fuel pump. Observe for fuel leaks.

Run outboard and check for fuel leaks.

**IMPORTANT:** Pay close attention to fuel vapor separator / fuel injector connection for leaks.

Repair any leaks before returning outboard to service.

## Intake Manifold Service

### Removal

Disconnect vapor separator vent hose, main bearing vent hose, air temperature sensor, crankshaft position sensor, and throttle position sensor.

Use Ball Socket Remover Tool, P/N 342226, to remove throttle link arm.

Remove throttle body screws and throttle body assembly.

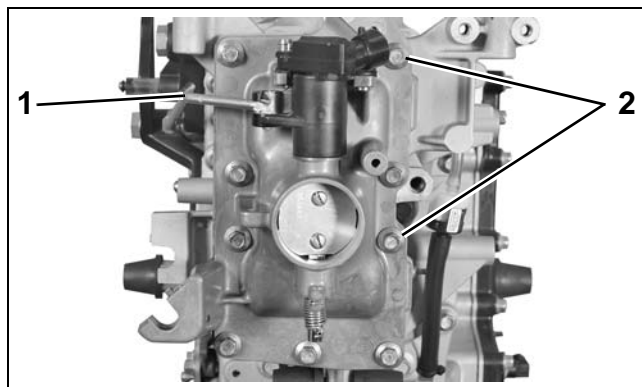

1. Link arm
2. Throttle body screws

007426

Remove gasket from throttle body.

Remove screws and reed plate assembly from the crankcase.

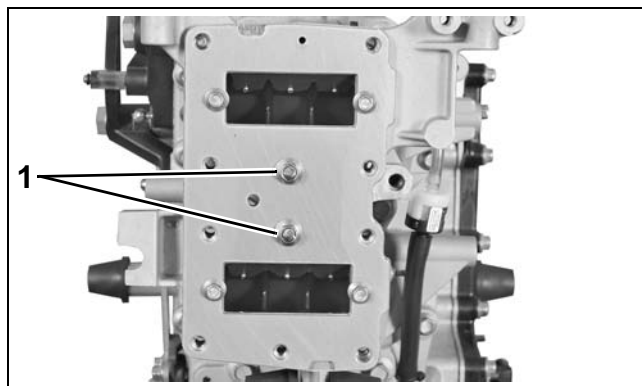

1. Screws

007427

### Disassembly

All reed plate assembly and reed valve assemblies must be cleaned prior to reassembly. **DO NOT** use strong carburetor cleaner or the hot soaking tank method for cleaning.

Remove the reed valve retainer screws and remove the assembly.

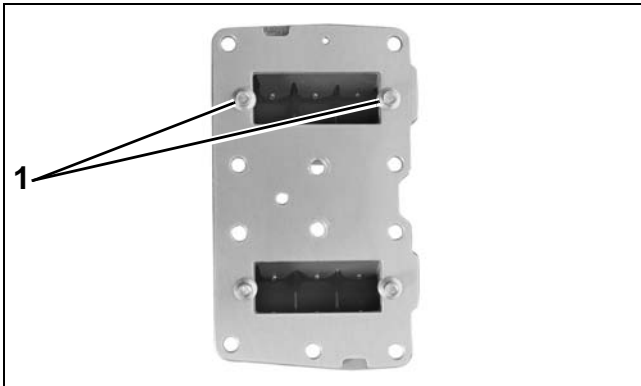

1. Screws

007428

Use caution to prevent damaging reed valve assemblies.



007429

**NOTICE** **DO NOT** disassemble reed valve assemblies. Damaged reed plates are not serviceable and are replaced as an assembly.

### Inspection

Inspect the leaf plate assemblies for damage or contamination:

- Leaf plates must not be distorted.
- Leaf valve must not be cracked or chipped.
- Leaf plate stops must not be distorted or loose.
- Leaf plate assemblies must be clean.

Inspect the intake manifold. All gasket surfaces must be cleaned, smooth, and free of nicks. Use a machinist's straight-edge and a feeler gauge to check flatness in all directions. Surface must be flat,  $\pm 0.004$  in. (0.10 mm).

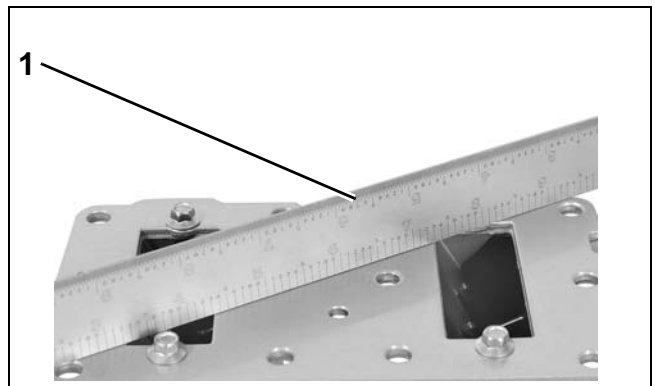

1. Straight-edge

007430

### Assembly

Remove old adhesive from reed valve retaining screws.

Install gasket on reed plate assembly. **DO NOT** use sealer on the gasket.



007431

## FUEL SYSTEM

### FUEL COMPONENT SERVICING

Prime screw threads with *Locquic Primer* and let dry. Apply *Ultra Lock* to threads. Position reed valve on reed plate and install screws. Tighten screws to a torque of 35 to 60 in. lbs. (4.0 to 6.8 N·m).



007432

#### Installation

Place reed plate assembly on cylinder/crankcase.

Apply *Nut Lock* to reed plate screws. Install and tighten screws to a torque of 84 to 106 in. lbs. (9.5 to 12 N·m).

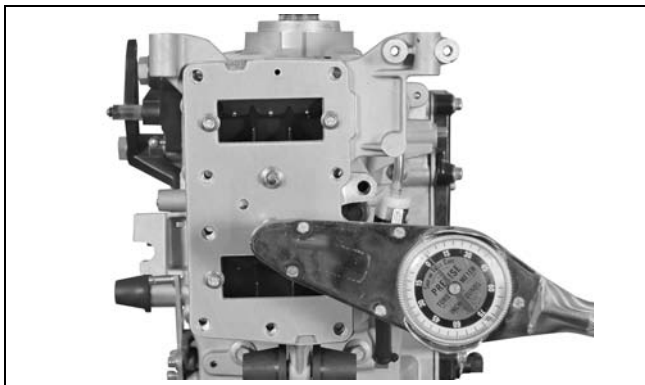

007433

Place gasket on throttle body. Install throttle body on reed plate and install **new** screws.

**IMPORTANT:** If old screws must be re-used, make sure all previous thread locking material is removed and apply *Nut Lock* to threads.

Tighten the center screws first and expand outward. Tighten in stages to a final torque of 84 to 106 in. lbs. (9.5 to 12 N·m).

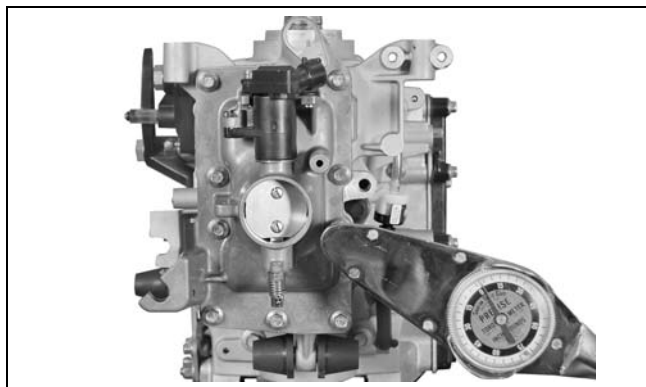

007434

Install vapor separator vent hose and main bearing vent hose. Secure with tie straps.

Install crankshaft position sensor, and throttle position sensor electrical connectors.

Connect throttle linkage.

**IMPORTANT:** DO NOT lubricate throttle linkages.

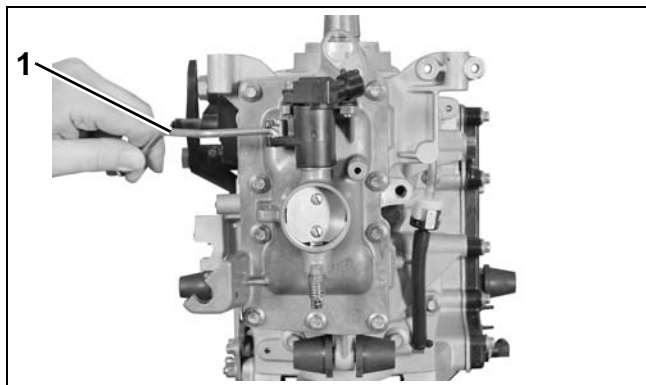

1. Throttle linkage

007435

Refer to **TPS Calibration** on p. 106.

# OILING SYSTEM

## TABLE OF CONTENTS

SERVICE CHART .....	142
OIL SUPPLY DIAGRAMS .....	143
OIL RECIRCULATION DIAGRAM .....	144
OILING SYSTEM CIRCUIT DIAGRAM .....	145
OIL SYSTEM REQUIREMENTS .....	146
RECOMMENDED LUBRICANTS .....	146
COMPONENTS .....	146
OIL TANK ASSEMBLY .....	146
OIL INJECTION PUMP .....	146
ELECTRICAL CIRCUIT (55 V) .....	147
LOW OIL WARNING .....	147
NO OIL WARNING .....	147
CYLINDER AND CRANKCASE .....	148
OIL RECIRCULATION SYSTEM .....	148
OIL CONTROL SETTINGS .....	149
OIL INJECTION RATE .....	149
BREAK-IN OILING .....	150
OIL SUPPLY PRIMING .....	150
OILING SYSTEM TESTS .....	151
OIL INJECTION PUMP VOLTAGE TEST .....	151
OIL INJECTION PUMP RESISTANCE TEST .....	152
OIL INJECTION PUMP FUNCTION TEST .....	153
OIL INJECTION FITTINGS FLOW TEST .....	153
LOW OIL SENDING UNIT TEST .....	153
OIL COMPONENT SERVICING .....	154
OIL DISTRIBUTION HOSES .....	154
OIL TANK ASSEMBLY .....	155
OIL INJECTION PUMP .....	156

**SERVICE CHART**

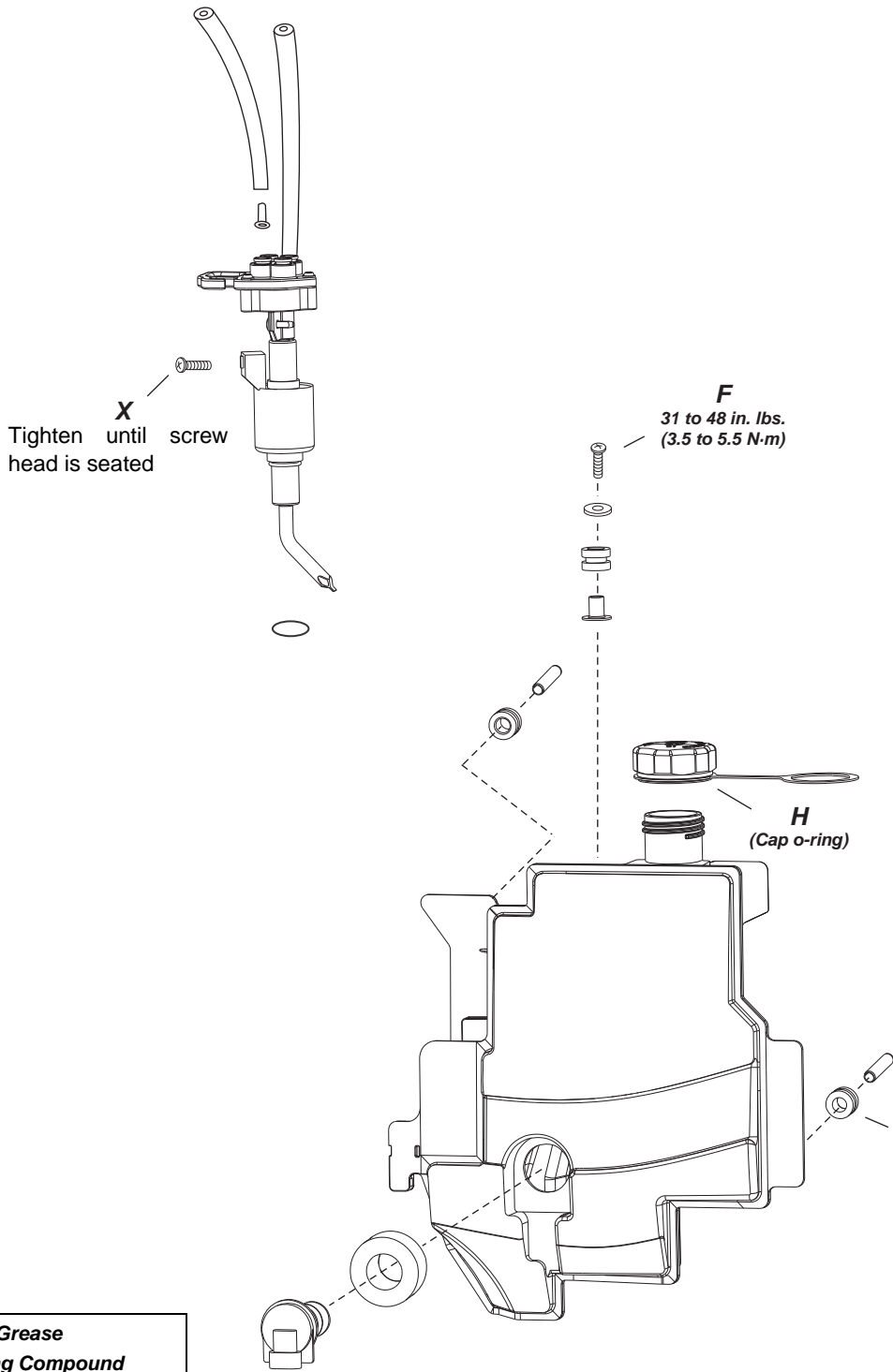

- A** Triple-Guard Grease
- B** Gasket Sealing Compound
- C** Adhesive 847
- E** Red Ultra Lock
- F** Blue Nut Lock
- H** Outboard Engine Lubricant
- X** See Service Manual instructions



# OIL SUPPLY DIAGRAMS

**IMPORTANT:** Note routing of oil supply hoses through hose retainer to oil manifold.

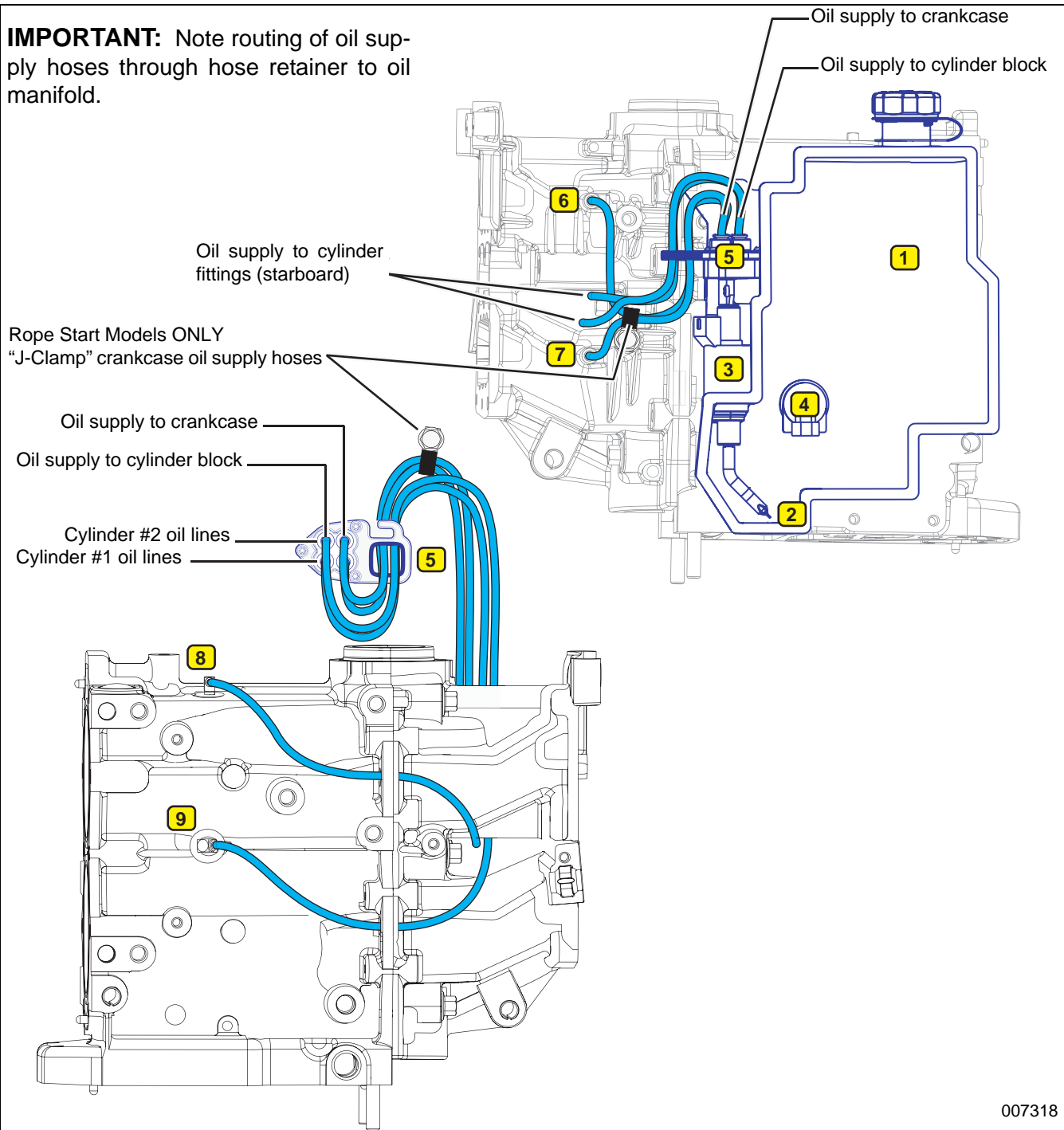

Rope Start Models ONLY

"J-Clamp" crankcase oil supply hoses

Oil supply to crankcase

Oil supply to cylinder block

Cylinder #2 oil lines

Cylinder #1 oil lines

Oil supply to crankcase

Oil supply to cylinder block

Oil supply to cylinder fittings (starboard)

007318

- |                              |   |
|------------------------------|---|
| 1. Oil tank                  | 6. #1 Cylinder crankcase oil inlet (port) |
| 2. Oil pick-up/filter        | 7. #2 Cylinder crankcase oil inlet (port) |
| 3. Oil injection pump        | 8. #1 Cylinder oil inlet (starboard)      |
| 4. Low oil level switch      | 9. #2 Cylinder oil inlet (starboard)      |
| 5. Oil distribution manifold |   |

# OIL RECIRCULATION DIAGRAM

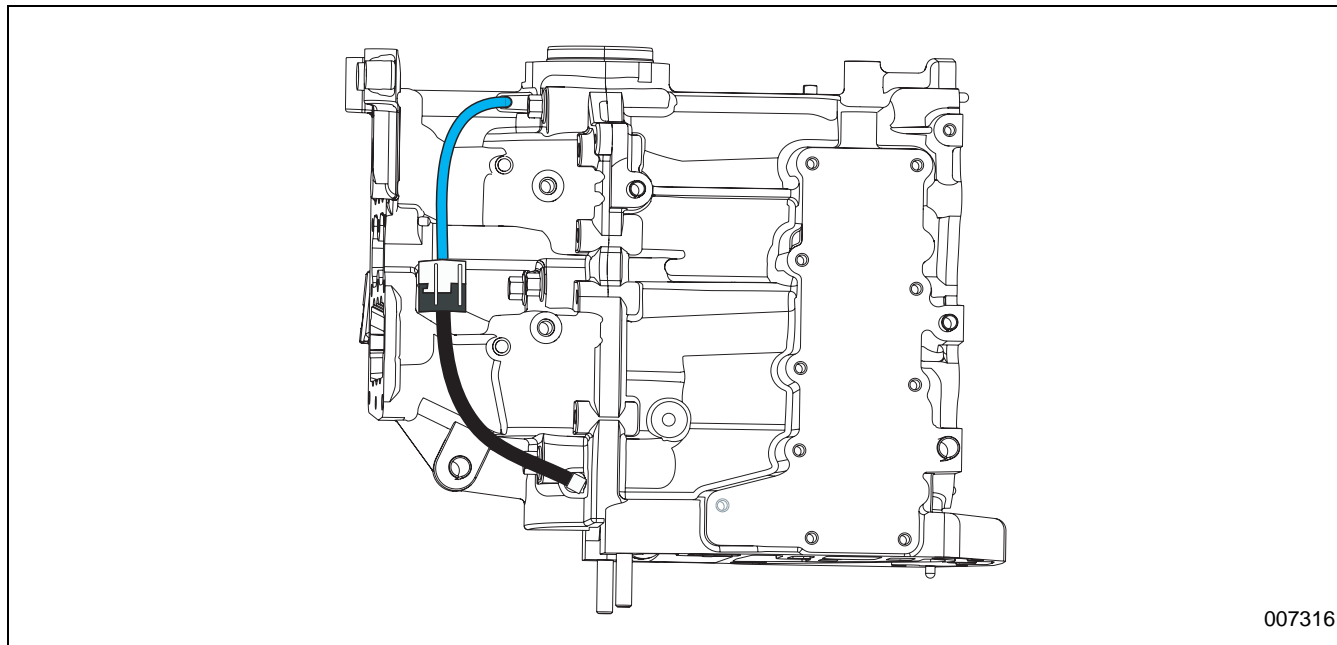

007316



## OIL SYSTEM REQUIREMENTS

### Recommended Lubricants

*Evinrude/Johnson XD100, XD50, or XD30* outboard oils are recommended for use in *Evinrude E-TEC* outboards. If these oils are not available, you must use a TC-W3 certified oil.

*Evinrude/Johnson XD100* outboard oil is highly recommended for all conditions and applications.

### Engine Lubricant Below 32°F (0°C)

If the outboard will be operated in temperatures below freezing (32°F, 0°C), use *Evinrude/Johnson XD100*.

**IMPORTANT:** For new outboards, test low oil warning before filling oil tank.

Turn key switch to ON. The engine monitor warning display should show “LOW OIL.”

Add enough oil to raise level to at least one-quarter capacity.

The “LOW OIL” warning should not display.

**NOTICE** Failure to follow these recommendations could void the outboard warranty if a lubrication-related failure occurs.

## COMPONENTS

The oiling system includes the following components:

- Oil tank
- Oil injection pump and manifold assembly
- Electrical circuit
- LOW OIL and NO OIL warning systems
- Cylinder and crankcase
- Oil recirculation system.

### Oil Tank Assembly

The oil tank is mounted on the powerhead under the engine cover. Oil level must be monitored.

Oil Tank Components:

- Tank, 1.5 quarts. (1.4 liter) capacity
- Oil pickup and filter assembly
- Oil injection pump and manifold assembly
- LOW OIL switch
- Oil distribution hoses

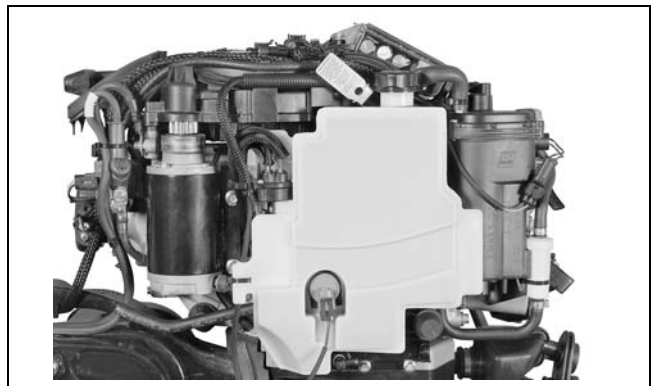

007320

### Oil Injection Pump

The oil injection pump is an electric (55 V) actuator style pump. It draws oil from the oil tank and supplies pressurized oil to the oil manifold. The *EMM* supplies 55 V and controls activation of the pump.

The oil manifold distributes the oil supplied by the pump.

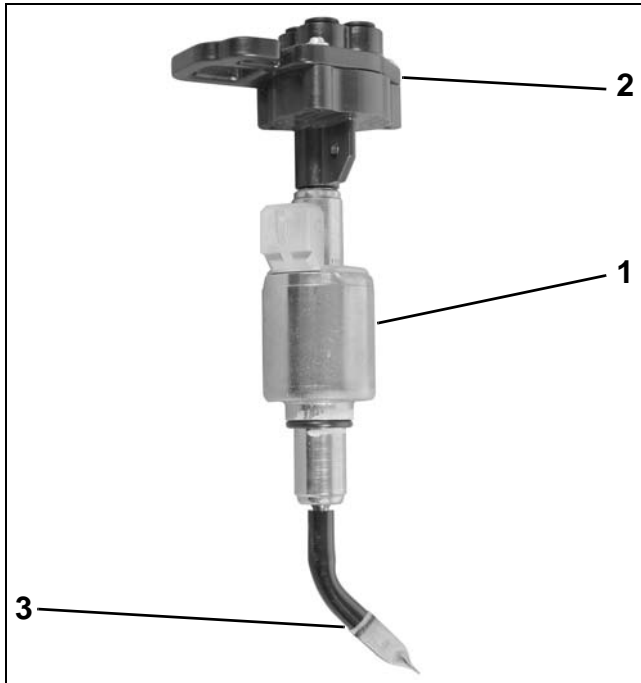

1. Oil injector pump  
2. Oil distribution manifold  
3. Pickup tube and filter

007321

### Electrical Circuit (55 V)

The oil injector is powered by the 55 V electrical circuit. The *EMM* controls pump operation by rapidly connecting and disconnecting the pump's internal coil to ground.

The *EMM* monitors the oil injection pump electrical circuit. If circuit voltage is beyond the specified range, or the circuit is open, the *EMM*:

Activates <i>S.A.F.E.</i>
Stores a service code 34
<i>EMM</i> LED 4: ON (Running)
Engine Monitor LOW OIL display: ON

### LOW OIL Warning

A switch in the oil tank assembly monitors the oil level in the oil tank.

If the oil level falls below one-quarter capacity, the *EMM* begins counting oil pump pulse cycles. When it reaches 1000 pulses, the *EMM* signals:

Engine Monitor LOW OIL display: ON
------------------------------------

Approximate oil reserve at Low Oil activation:

- 0.375 qt. (0.35 l).

### NO OIL Warning

After LOW OIL is displayed, the *EMM* counts oil pump pulse cycles again. When it reaches 6700 pulses, the *EMM*:

Activates <i>S.A.F.E.</i>
Stores service code 117
<i>EMM</i> LED 4: ON (Running)
Engine Monitor LOW OIL display: ON

To recover from *S.A.F.E.* mode:

- Oil level must be above one-quarter
- The warning resets after three oil pump pulse cycles when the outboard has been stopped and restarted.

If outboard has been run for more than 3 hours with NO OIL faults (codes 34 & 117), the *EMM*

Activates SHUTDOWN
Stores service code 33
<i>EMM</i> LED 4: FLASHING
Engine Monitor LOW OIL display: FLASHING

# OILING SYSTEM

## COMPONENTS

### Cylinder and Crankcase

The oil distribution manifold provides crankcase lubrication through oil distribution hoses and pressed-in fittings on the crankcase and cylinder block.

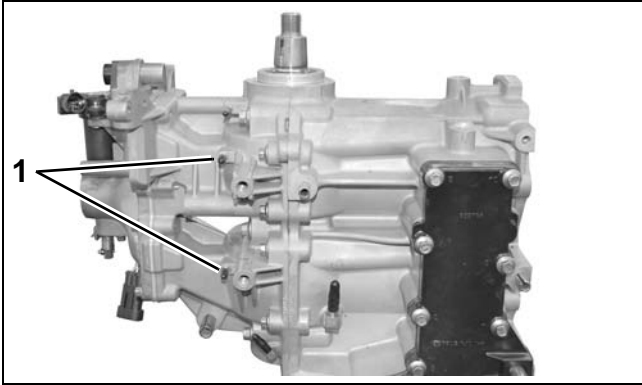

1. Crankcase oil fittings

007322

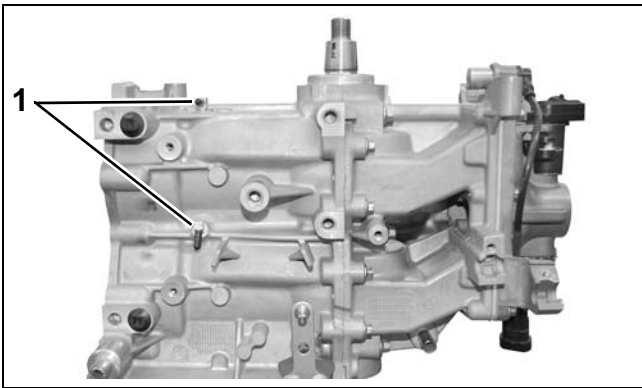

1. Cylinder block oil fittings

007323

### Oil Recirculation System

External hoses and fittings, and intake manifold passages are used to recirculate any accumulation of oil from various locations in the powerhead. The movement of oil is controlled by check valves.

#### Crankcase / Main Bearing Recirculation

The movement of oil through the main bearings is controlled by internal passages, external fittings and hoses, and check valves.

##### Lower to upper main bearing oil flow:

- Lower main bearing cavity to internal crankcase passage to external fitting, external hoses with in-line check valve to external fitting at upper main bearing, and into upper main bearing through internal crankcase passage.

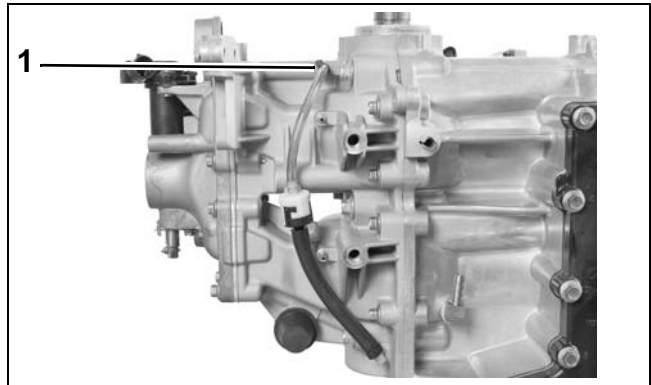

1. Upper main bearing vent

007324

Refer to the **OIL RECIRCULATION DIAGRAM** on p. 144.

# OIL CONTROL SETTINGS

## Oil Injection Rate

EMM programming controls the rate of oil injection based on engine RPM. This rate can be adjusted for the type of oil being used, and also for powerhead break-in. Use *Evinrude Diagnostics* software to access these features.

The *Set Oil Type* option controls the injection rate for the oil being used and typical operating conditions.

The TC-W3 oil type setting is the standard setting for all outboards. Set TC-W3 for:

- Operation with all TC-W3 outboard oils including *XD30*, *XD50*, or *XD100*.
- Applications requiring maximum lubrication.
- Extreme applications (commercial or harsh conditions, racing or other high performance operation).
- Use this setting with *XD100* outboard oil in extreme applications

The *XD100* setting provides an option to run the outboard at a reduced oil injection rate. This setting **REQUIRES** the use of *Evinrude XD100* outboard lubricant and is not recommended for all applications.

**IMPORTANT:** The *XD100* setting is not available on all models.

Use the *XD100* setting for:

- Conventional use (runabouts, cruisers)
- Moderate applications

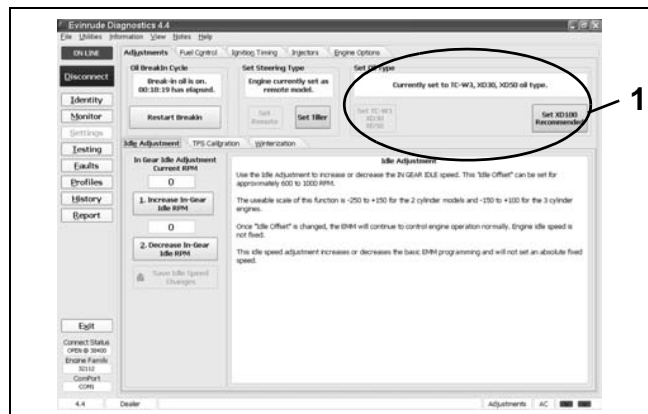

1. Oil control setting

008084

### ⚠ CAUTION

Running an *Evinrude E-TEC* outboard on other grades of oil while set to the *XD100* oil ratio will result in increased engine wear and shortened outboard life.

Powerhead oil programming labels are provided to identify *EMM* oil programming. Install the correct label to alert user to specific oil requirements.

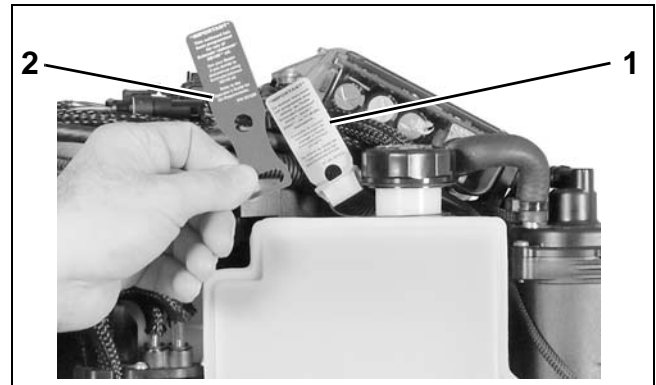

1. Evinrude/Johnson *XD30* outboard lubricant (TC-W3) 007265 **YELLOW label**
2. Evinrude/Johnson *XD100* outboard lubricant (Premium) **BLUE label (Installed)**

An *XD100* Outboard Oil Decal, P/N 352369, is available to label boats equipped with outboards that have been programmed for the reduced oil injection ratio.

8

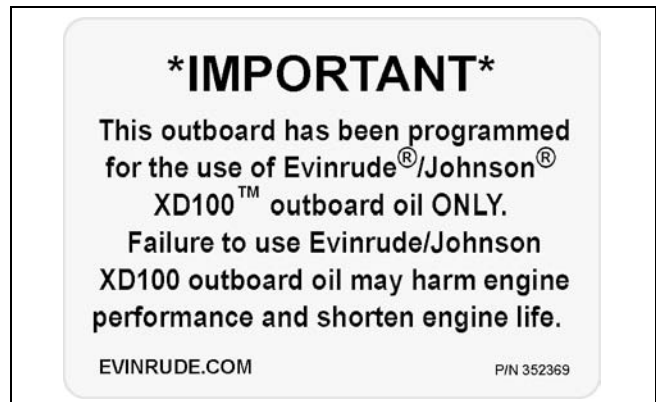

*XD100* Outboard Oil Decal

004522

## OILING SYSTEM

### OIL CONTROL SETTINGS

Install decals in a highly visible location, such as one of the following:

- Dashboard/deck of boat, next to key switch
- Deck of boat, next to the remote oil fill
- Deck of boat, next to oil tank assembly
- Oil tank cover
- Cover of oil tank compartment
- Attach to oil tank or oil fill cap.

**IMPORTANT:** Make sure the engine label and boat decals match *EMM* programming.

### Break-In Oiling

**IMPORTANT:** DO NOT add oil in the fuel tank on *Evinrude E-TEC* models.

The *EMM* automatically supplies extra oil to the engine as follows:

- 15 – 30 HP: First two hours above 2000 RPM

Follow these steps for outboard set-up:

- Use *Evinrude Diagnostics* software to make sure the break-in program has been started on a new outboard.
- Use the diagnostics software to start break-in oiling after a powerhead rebuild.



1. Break-in oil setting

008084

**NOTICE** The operator must monitor the oil tank level to confirm oil consumption. This may require several hours of operation above idle.

## Oil Supply Priming

### WARNING

Always use caution while working around machinery with moving parts. The following set-up procedures require running tests that are performed with the outboard's motor cover removed.

Start the outboard. Use the oil priming function in the software to make sure the system is completely primed.

Use the *Prime Oil System* button of the *Dynamic Test* screen to prime the oil pump.

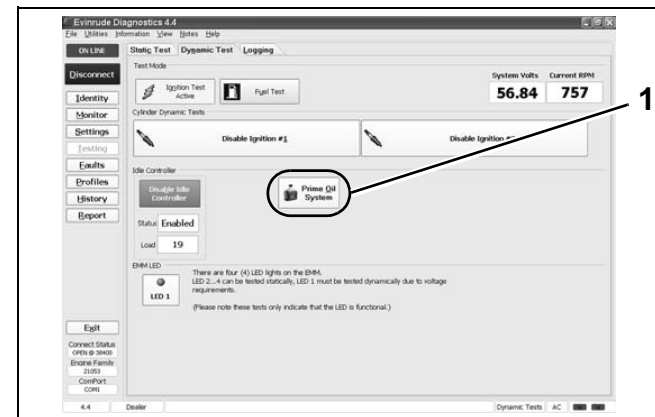

Dynamic Test Screen

1. Prime Oil System button

008135



Observe oil flow through all oil distribution hoses. Air must be purged during the priming procedure.

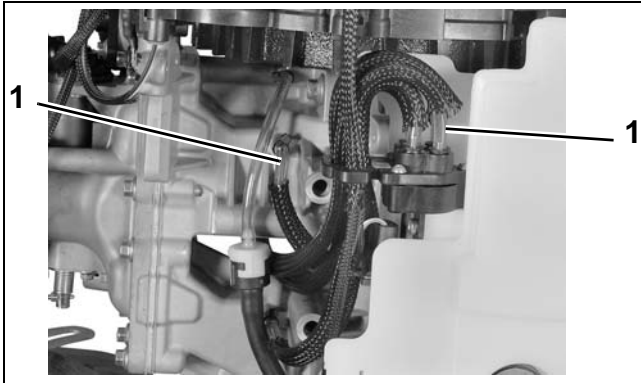

1. Oil distribution hoses 007130

Small bubbles are acceptable. Large bubbles must be eliminated through continued priming.

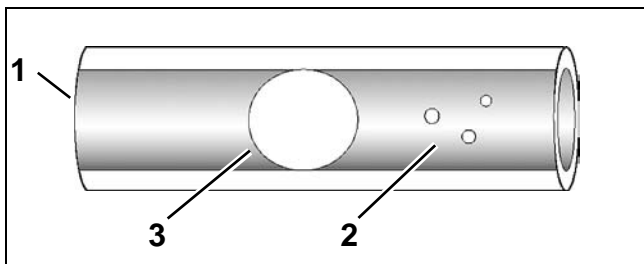

1. Oil distribution hose  
2. Small bubbles  
3. Large bubbles 004398

Repair any fuel or oil leaks.

The oiling system on these models can also be primed using the Self-Winterizing feature if diagnostics software is not available. Refer to **STORAGE** on p. 39.

## OILING SYSTEM TESTS

**IMPORTANT:** Always perform visual inspections to identify oiling system leaks. Make sure the oil tank is filled and oil supply is not contaminated.

### Oil Injection Pump Voltage Test

**IMPORTANT:** Do NOT perform static tests using Diagnostic Power Supply Tool, P/N 587005, with internal 9 volt batteries only. This will produce false results. Refer to **Communication** on p. 58.

The *EMM* controls the pump by providing ground through pin 2 (blue wire) of the J1-A connector and pin A (blue wire) of the oil pump connector.

Acceptable Oil Injection Pump Test Readings	
Key switch ON	approximately 12 VDC
Control signal	approximately 1.2 Hz
Engine running	approximately 55 VDC

Use a digital multimeter calibrated to a scale that reads 12 V (DC) to measure voltage between the oil pump electrical connector and engine ground.

Connect negative meter lead to ground.

Use an appropriate test probe to connect positive meter lead to pin A (blue wire) of oil injection pump electrical connector.

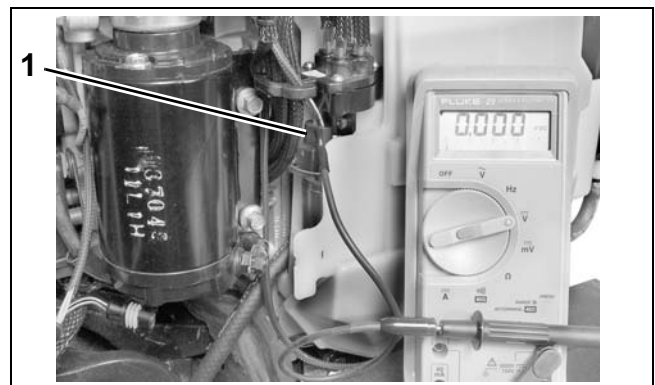

1. Oil injection pump electrical connector 008425

Turn the key switch to the ON position. Observe voltage at pin A.

- Voltage at pin A should be approximately 12 V.

# OILING SYSTEM

## OILING SYSTEM TESTS

Use the *Oil Injector* test of *Evinrude Diagnostic* software *Static Test* screen to activate the oil pump.

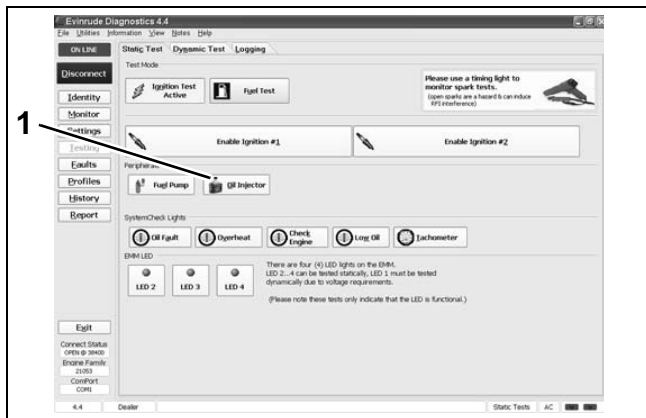

**Static Tests Screen** 008140  
1. *Oil injector test button*

**IMPORTANT:** This test is operating the pump with 12 V battery power on the system voltage (55 V) circuit. The oil injection pump will not pump oil when operating on 12 V.

Observe voltage at pin A.

- Voltage at pin A should drop as the oil pump cycles.

Check the control signal while the *Oil Injector* test is running. Set the digital multimeter to the Hertz (Hz) scale.

- Meter should read approximately 1.2 Hz.

Results:

- If voltage and control signal readings at pin A are within range, the *EMM* and wiring are not at fault.
- If voltage at pin A is not within range, check voltage at pin B (white/red wire) of oil pump electrical connector.

Connect positive meter lead to pin B (white/red wire) of oil injection pump electrical connector. Observe voltage at pin B.

- Voltage at pin B should be approximately 12 V.

Set digital multimeter to a scale that reads 55 V (DC).

Start the engine. Observe voltage at pin B.

- Voltage at pin B should be approximately 55 V.
- If voltage at pin B is within range, refer to **Oil Injection Pump Resistance Test** on p. 152.
- No voltage reading at pin A, refer to **System Voltage Test** on p. 74.

## Oil Injection Pump Resistance Test

Disconnect the battery cables at the battery.

Disconnect the electrical connector from the oil injection pump.

Use a digital multimeter to measure the resistance between the pins of the oil injection pump connector. Calibrate the meter to the LOW OHMS scale.

Oil Injection Pump Resistance
22 Ω



1. *Oil injection pump connector* 008426

Results:

- An infinite reading ( $\infty$ ) indicates an open circuit of the injection pump winding. Replace faulty pump.

## Oil Injection Pump Function Test

Remove oil distribution hose from fitting at oil distribution manifold. Do not lose the brass hose support.



1. Oil distribution hose

007330

Temporarily install a length of oil hose.

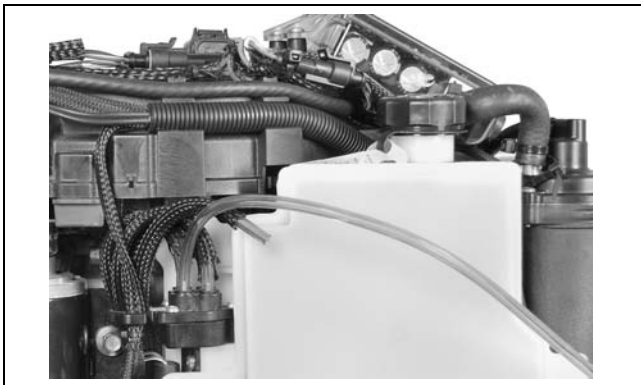

007331

Start the outboard and observe oil flow:

- Oil flows from hose, compare to oil flow at other distribution fittings
- If one or more fittings fail to flow oil, replace the oil injection pump assembly.

Reinstall hose into manifold.

**IMPORTANT:** Make sure hose support is in hose and hose is fully inserted into manifold. Refer to **Oil Distribution Hoses** on p. 154.

## Oil Injection Fittings Flow Test

Make sure the oil injection fittings of the cylinder and crankcase assembly allow fluid to move.

Remove oil distribution hose from oil distribution manifold.

Use a Syringe, P/N 346936, filled with isopropyl alcohol to force fluid through hose and fitting.

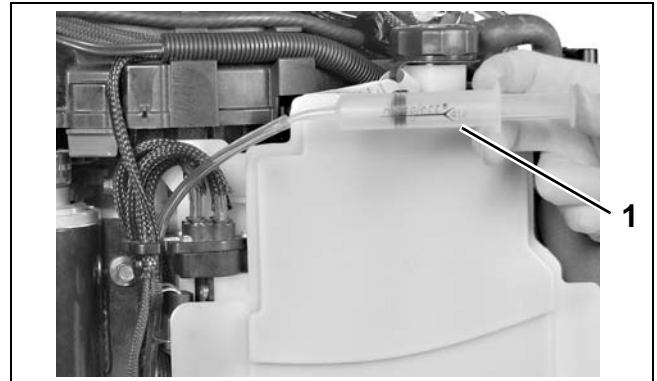

1. Syringe

007332

## LOW OIL Sending Unit Test

Remove oil from the oil tank.

Turn the key switch ON. The dash mounted Engine Monitor system should show a LOW OIL warning.

Once the warning has been confirmed, refill the oil tank and start the outboard. The LOW OIL warning should stop after the oil pump cycles 3 times.

# OIL COMPONENT SERVICING

**⚠ WARNING**

To prevent accidental starting while servicing, twist and remove spark plug leads.

## Oil Distribution Hoses

Oil distribution hoses are different lengths. DO NOT alter the length of any hoses.

Oil Distribution Hose Length:

- Cylinder – 20 in. (508 mm)
- Crankcase – 10.5 in. (267 mm)

## Removal

Release the hose by depressing the outer ring of the hose retaining mechanism.

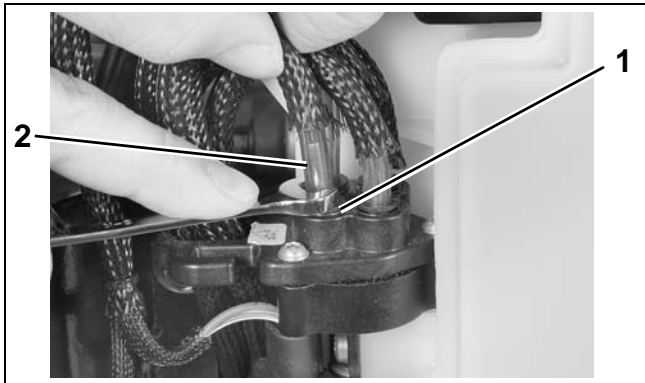

1. Retainer mechanism  
2. Hose support  
007330

Once hose is removed from the manifold, make sure hose support is in the end of the hose.

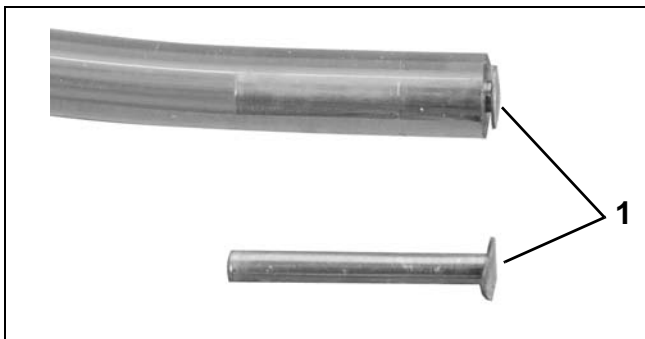

1. Hose support  
007333

## Installation

Cut Replacement Oil Hose, P/N 778708, to the correct length. Insert hose support in manifold end of hose.

**IMPORTANT:** DO NOT insert distribution hoses into manifold without a hose support.

Be sure the hose is fully inserted into manifold. Insertion depth is 5/8 in. (16 mm). Visually inspect for hose supports.

Oil distribution hoses have specific locations and routing. DO NOT alter the location of any hoses.

The oil distribution manifold includes a built-in hose retainer. Route oil distribution hoses up through the retainer.

Install crankcase oil distribution hoses to the forward oil manifold ports.

Install cylinder #1 oil hose to the inner (closest to powerhead) oil manifold port.

Install cylinder #2 oil hose to the outer (furthest from powerhead) oil manifold port.

Loop the cylinder block oil distribution hose over the crankcase oil distribution hose and install to the rear oil manifold port.

Install cylinder #1 oil distribution hose to the inboard (closest to powerhead) oil manifold port.

Install cylinder #2 oil distribution hose to the out-board (furthest from powerhead) oil manifold port.

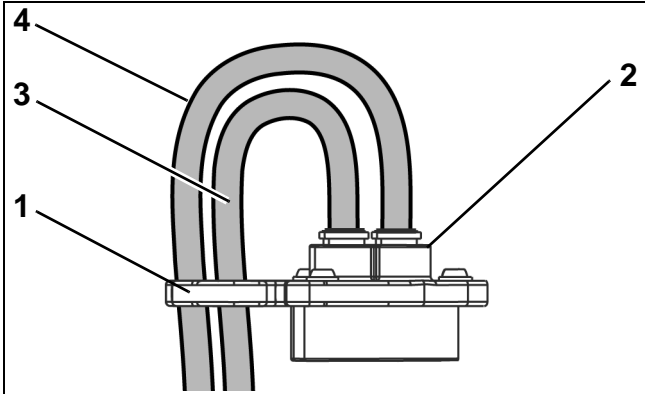

- 1. Hose retainer
  - 2. Oil distribution manifold
  - 3. Crankcase oil supply hose
  - 4. Cylinder block oil supply hose
- 007334

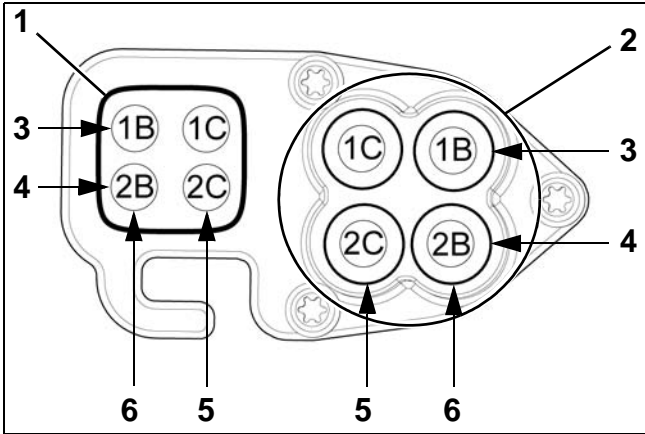

- 1. Hose retainer
  - 2. Oil distribution manifold
  - 3. #1 Cylinder
  - 4. #2 Cylinder
  - 5. Crankcase
  - 6. Cylinder block
- 007335

Refer to **OIL SUPPLY DIAGRAMS** on p. 143.

### Oil Tank Assembly

#### Removal

Disconnect the battery cables at the battery.

Disconnect the electrical connector to the oil injection pump.

Disconnect the electrical connector to the low oil switch.

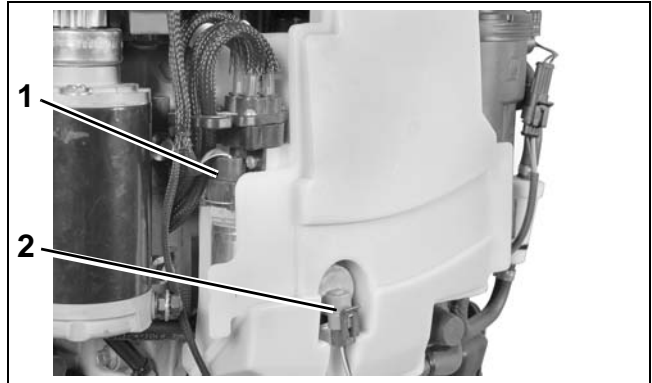

- 1. Oil pump connector
  - 2. Low oil switch
- 007336

**IMPORTANT:** Note oil distribution hose routings before proceeding with disassembly.

Remove oil distribution hoses from the manifold.

Remove oil tank retaining screw.



- 1. Screw
- 007288

## OILING SYSTEM

### OIL COMPONENT SERVICING

#### Installation

Align grommets with pins on powerhead. Install oil tank assembly on powerhead. Clean mounting screw and apply *Nut Lock* to threads. Install screws and tighten to a torque of 30 to 42 in. lbs. (3.5 to 5 N·m).

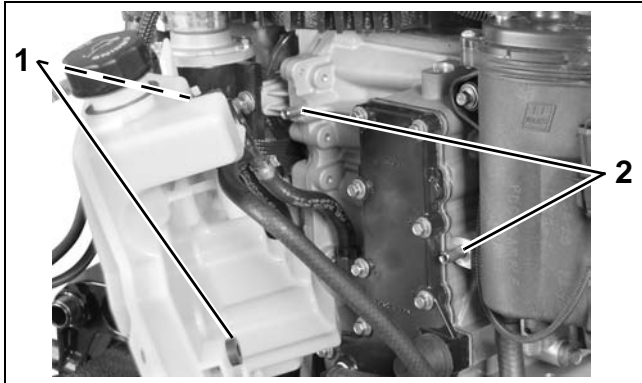

1. Grommets  
2. Pins  
007107

Install protective sleeves and route oil distribution hoses from the oil distribution manifold to the crankcase and cylinder block oil delivery fittings. Refer to **OIL SUPPLY DIAGRAMS** on p. 143. Secure oil hoses to crankcase and cylinder block fittings with tie straps. On rope start models, install J-clamp to retain two crankcase oil supply hoses.

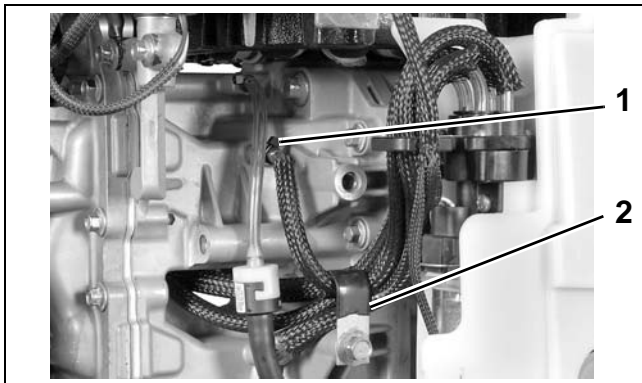

1. Tie strap  
2. Clamp  
007337

Run outboard and check for leaks. Use *Evinrude Diagnostics* software to activate "Oil Prime." Check oil flow through oil distribution hoses. Check oil system operation and routing of oil system hoses.

Repair any oil leaks and kinked or misrouted hoses. Install engine covers.

#### Oil Injection Pump

##### Removal

Remove oil distribution hoses from oil manifold. Refer to **Oil Distribution Hoses** on p. 154.

Remove oil from oil tank.

Remove oil tank. Refer to **Oil Tank Assembly** on p. 155. Remove retaining screw from oil pump assembly. Twist and pull up on oil pump to remove from tank.

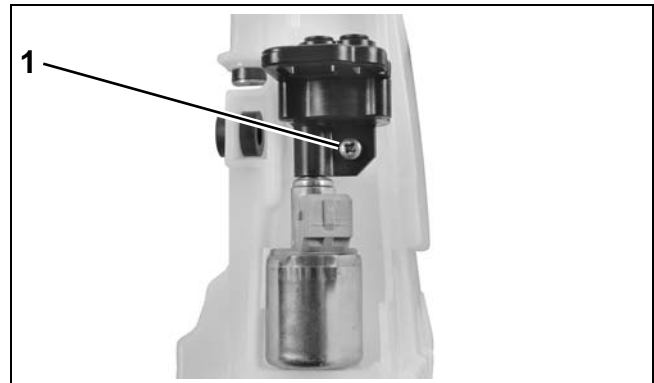

1. Screw  
007338

##### Installation

Apply a drop of outboard lubricant to a new oil pump o-ring. Install o-ring on oil pump flange.

Installation is the reverse of removal.

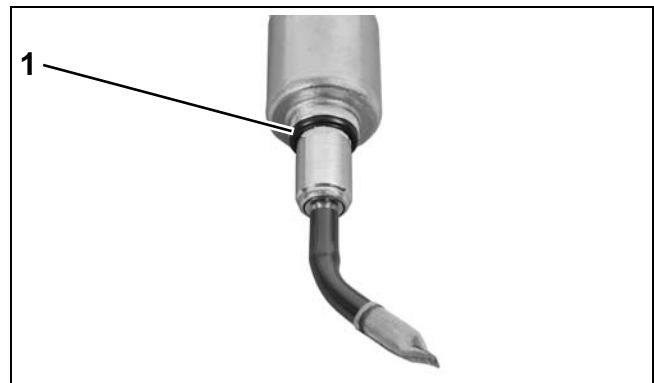

1. O-ring  
007339

Install oil pump retainer screw. Tighten securely.

**IMPORTANT:** Turn self-tapping screws counter clock-wise to start the threads and clockwise to tighten. Failure to follow this procedure can damage the threads of the oil tank.

# COOLING SYSTEM

## TABLE OF CONTENTS

- HOSE ROUTING AND WATER FLOW DIAGRAMS .....158
- COMPONENTS .....159
  - WATER PUMP AND INTAKES .....159
  - EXHAUST HOUSING .....159
  - PRESSURE RELIEF VALVE .....160
  - THERMOSTAT .....160
- OPERATION .....161
  - CYLINDER BLOCK / CYLINDER HEAD COOLING .....161
  - VAPOR SEPARATOR, *EMM* AND BATTERY CHARGE MODULE COOLING .....161
- ENGINE TEMPERATURE CHECK .....162
  - SOFTWARE METHOD .....162
  - PYROMETER METHOD .....162
  - IDLE OPERATING TEMPERATURE TROUBLESHOOTING (BELOW RANGE) .....163
- TEMPERATURE SENDER SERVICING .....164
  - REMOVAL .....164
  - INSTALLATION .....164
- THERMOSTAT AND PRESSURE RELIEF VALVE SERVICING .....164
  - DISASSEMBLY .....164
  - INSPECTION .....165
  - ASSEMBLY .....165

# HOSE ROUTING AND WATER FLOW DIAGRAMS

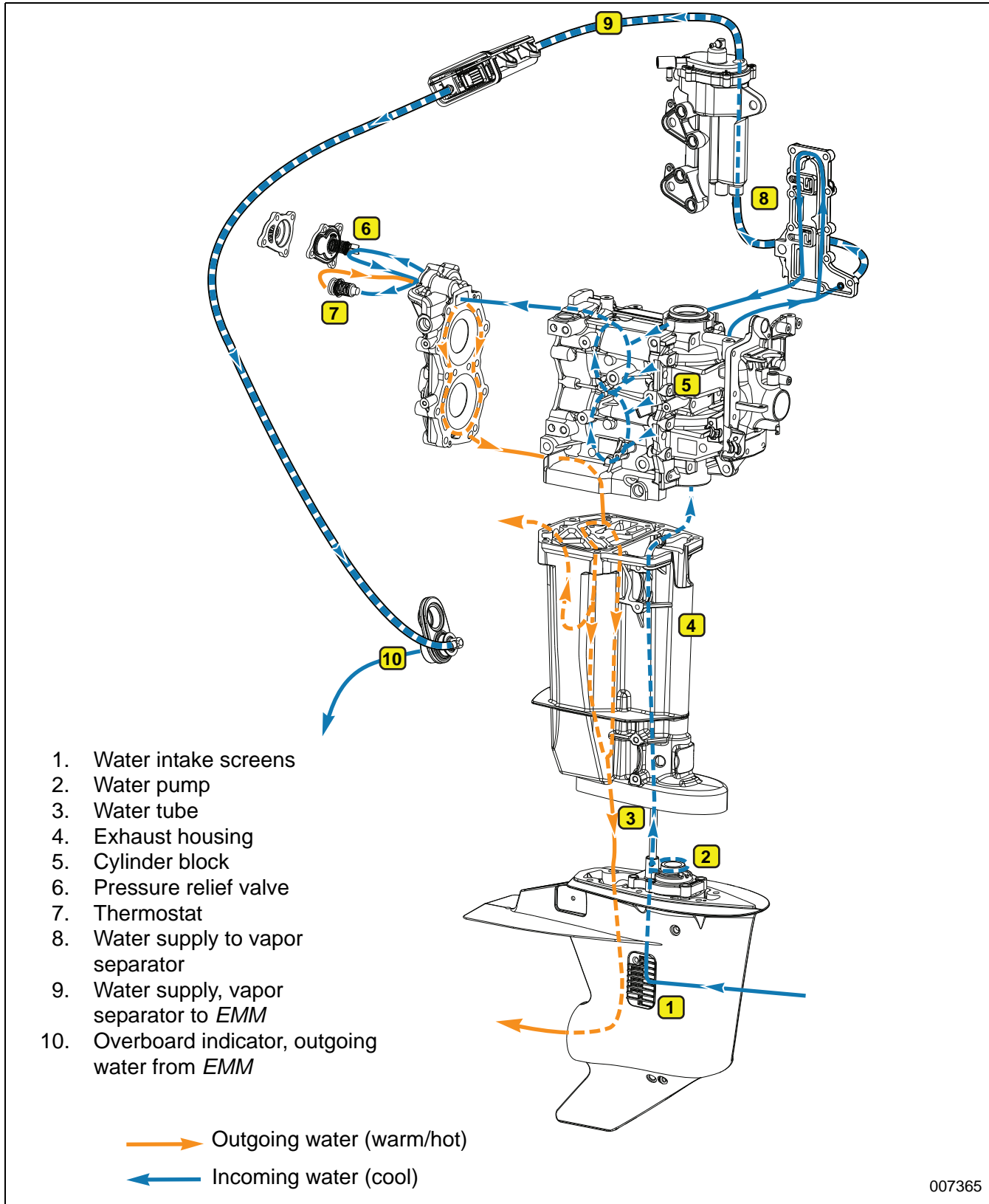

007365



# COMPONENTS

## Water Pump and Intakes

External water intakes mounted in the gearcase housing collect water and must supply the inlet side of the water pump with an unrestricted and unaerated water supply. Water is drawn into the water pump through a hole in the lower plate of the water pump assembly. All cooling water to the powerhead is provided by the water pump.

- A nylon wedge (impeller key) is used to engage the impeller bushing and driveshaft.
- The nylon impeller housing with liner must seal against a separate water pump plate.
- The bottom plate **MUST** seal to gearcase.

Refer to **WATER PUMP SERVICE** on p. 250 for servicing.

**IMPORTANT:** The water pump housing includes a small vent hole to the side of the water outlet. Be sure to use the correct parts when replacing the water pump.

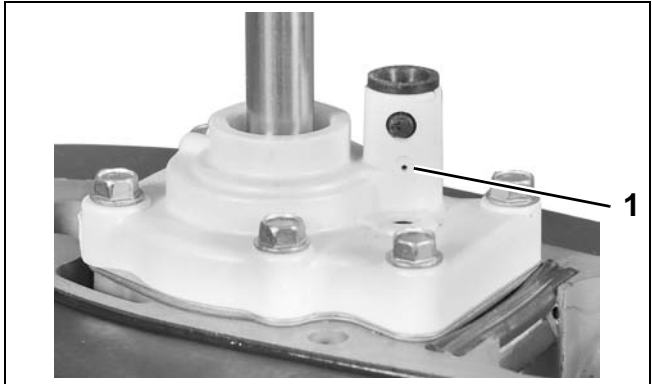

1. Hole

007368

## Exhaust Housing

The water pump outlet connects with a water tube and passages located in the outboard's midsection. Grommets seal the water pump housing to the water tube and the water tube to the exhaust housing.

Water supplied to the exhaust housing provides all cooling water to the cylinder block.

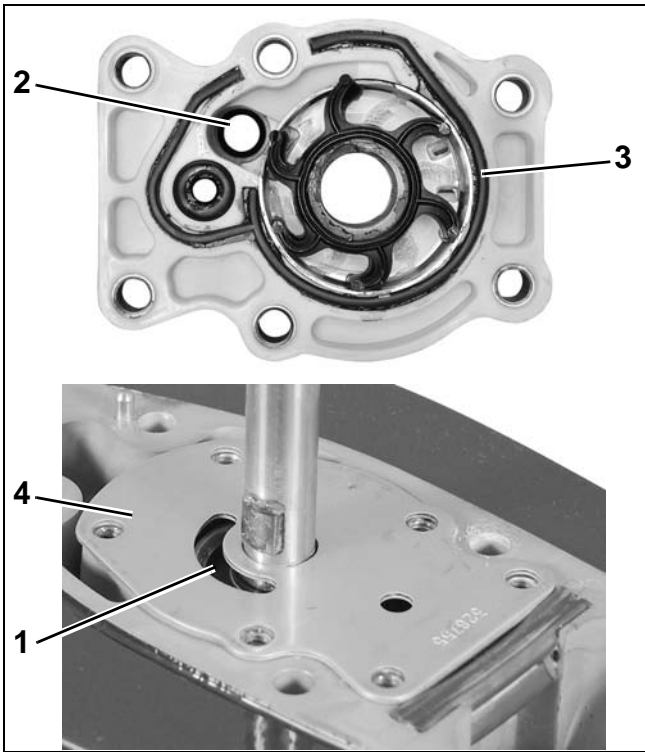

- 1. Water inlet
- 2. Water outlet
- 3. Seal
- 4. Plate

007366

007367

## COOLING SYSTEM COMPONENTS

### Pressure Relief Valve

A pressure relief valve is used to control water flow and operating temperature at higher speeds (above approximately 2800 RPM). The pressure relief valve opens as water pressure increases. Spring tension sets the opening pressure.

**Overheating:** A restricted or faulty valve typically results in HIGH SPEED overheating.

**Overcooling:** Debris may prevent the valve from closing completely.

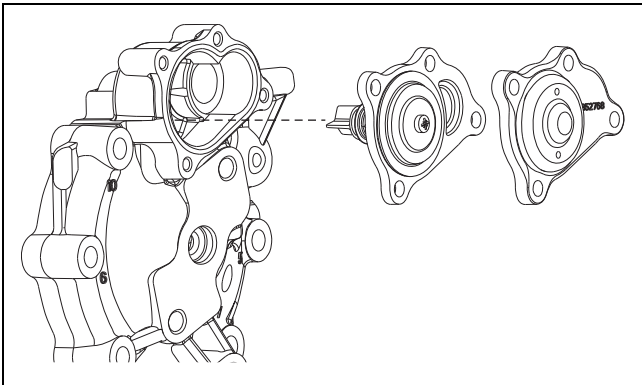

Pressure relief valve components

007369

### Thermostat

The thermostat controls water flow and operating temperature at lower speeds (below 1800 RPM).

**Overheating:** A restricted or faulty thermostat typically results in LOW SPEED overheating.

**Overcooling:** Debris may prevent the thermostat from closing completely.

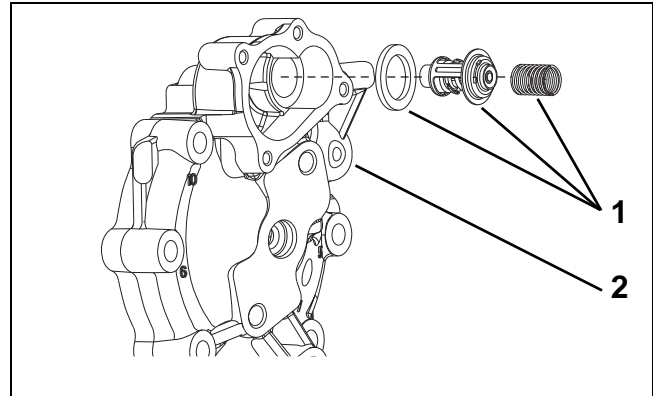

1. Spring, thermostat and gasket
2. Cylinder head

007370

## OPERATION

All models use a two-stage cooling system design. The cooling system is dependent on water pump pressure and controlled by thermostat and pressure valve operation.

**NOTICE** Restricted or inadequate water flow through the outboard reduces cooling system performance and may lead to severe power-head damage.

### Cylinder Block / Cylinder Head Cooling

The flow of water through the cylinder block and cylinder head is controlled by a thermostat and a pressure relief valve. The thermostat and pressure valve are located in the top of the cylinder-head.

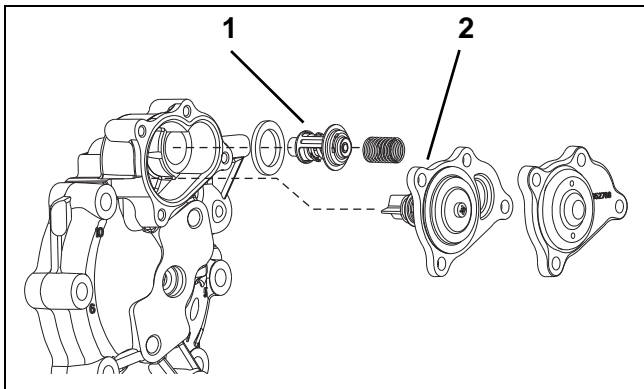

1. Thermostat  
2. Pressure valve assembly

007371

The thermostat and pressure valve control the flow of water entering the vertical water passages of the cylinder head.

**At low speed**, the pressure valve is against the seat and the thermostat is closed. Warm water from the cylinder block gradually migrates to the thermostat pocket at the top of the cylinder head.

The thermostat opens when the water temperature reaches approximately 143°F (62°C).

When the thermostat opens, water flows down through the cylinder head to a passage in the cylinder block. Water flows through the block to the exhaust housing and then out of the outboard.

**At higher speeds**, water pressure opens the pressure relief valve at approximately 2800 RPM. Water flows through the valve to the cylinder head and bypasses the thermostat. All water flows through the cylinder head to the outlet passage of the block and then exits through the exhaust housing.

### Vapor Separator, *EMM* and Battery Charge Module Cooling

Cooling water is routed from the exhaust cover to the inlet fitting of vapor separator water cavity. Cooling the vapor separator fuel chamber minimizes fuel vaporization.

Cooling water from the vapor separator is routed to the water inlet fitting of the *EMM* water cavity. Cooling of the *EMM* helps to stabilize the temperatures of internal components.

**IMPORTANT:** Improper *EMM* cooling will activate service codes 25 and 29 and the Engine Monitor warning system. Refer to the ***EMM* Service Code Chart** at the back of this manual for specific service code information.

On rope start models, cooling water from the *EMM* is routed to the overboard indicator.

On electric start models, cooling water from the *EMM* is routed to the water inlet fitting of the battery charge module water cavity. Cooling water from the battery charge module is routed to the overboard indicator.

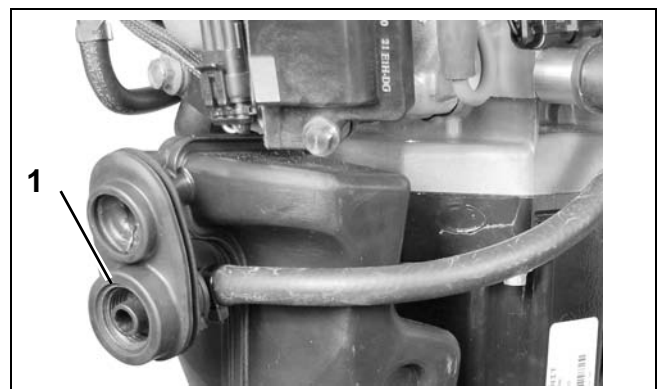

1. Overboard indicator

007372

## COOLING SYSTEM ENGINE TEMPERATURE CHECK

# ENGINE TEMPERATURE CHECK

**IMPORTANT:** The engine temperatures listed below are based on an intake water temperature of  $70^{\circ} \pm 10^{\circ}\text{F}$  ( $21^{\circ} \pm 3^{\circ}\text{C}$ ).

Install correct propeller and place outboard in a test tank or in the water. Start outboard and run at 3000 RPM in FORWARD gear for at least five minutes. Remember, running outboards at high speeds in test tanks may disrupt water flow to gearcase water intakes. Make sure the outboard has adequate water flow.

### CAUTION

**When servicing the propeller, always shift the outboard to NEUTRAL, turn the key switch OFF, and twist and remove all spark plug leads so the engine cannot be started accidentally.**

Reduce speed to IDLE for five minutes. Check IDLE operating temperature.

Increase speed to 5000 RPM and check temperature.

If engine temperatures are not within range, troubleshoot cooling system.

## Software Method

Use *Evinrude Diagnostics* software to read temperature displays.

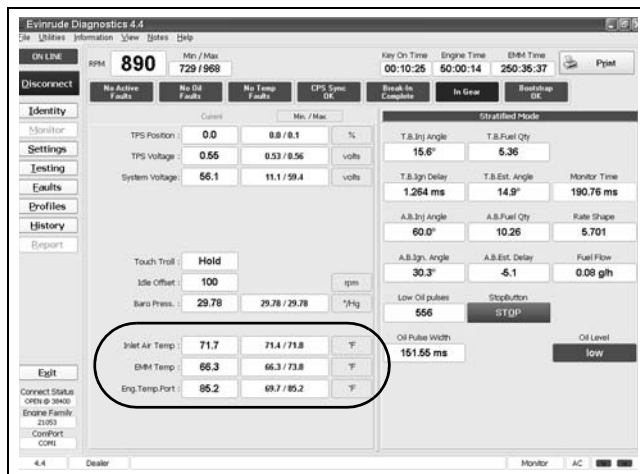

Monitor Screen

008137

Typical temperature sensor readings at IDLE speed should be  $167^{\circ}\text{F} \pm 5^{\circ}\text{F}$  ( $73^{\circ}\text{C} \pm 3^{\circ}\text{C}$ ).

Typical temperature sensor readings at WOT speed should be  $122^{\circ}\text{F} \pm 10^{\circ}\text{F}$  ( $50^{\circ}\text{C} \pm 5^{\circ}\text{C}$ ).

Operating temperature must not exceed  $212^{\circ}\text{F}$  ( $100^{\circ}\text{C}$ ).

## Pyrometer Method

Use a Temperature Gun, P/N 772018, or a digital pyrometer to measure the outboard's operating temperatures.

Measure temperature of the thermostat housing at the top of cylinder head.

Typical pyrometer readings at IDLE speed should be  $135^{\circ}\text{F} \pm 10^{\circ}\text{F}$  ( $57^{\circ}\text{C} \pm 5^{\circ}\text{C}$ ).

Typical pyrometer readings at WOT speed should be  $110^{\circ}\text{F} \pm 10^{\circ}\text{F}$  ( $43^{\circ}\text{C} \pm 5^{\circ}\text{C}$ ).

**IMPORTANT:** If you get low or inaccurate readings with a digital pyrometer, coat the probe location with *Thermal Joint Compound*, P/N 322170.

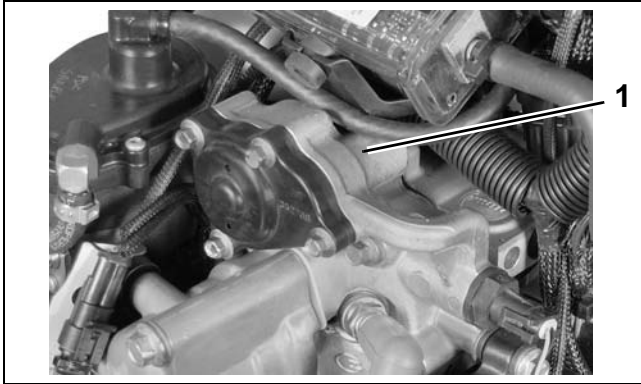

Thermostat housing

007374

**IMPORTANT:** Digital pyrometer or temperature gun measurements may be slightly lower than software temperature readings.

### Idle Operating Temperature Troubleshooting (Below Range)

If engine IDLE temperature is below operating range, 167°F ± 5°F (73°C ± 3°C), check thermostat and pressure relief valve operation.

#### Thermostat Inspection

Check position of thermostat seal and how thermostat seals against cylinder head. Seal must be properly fitted to flange of thermostat.

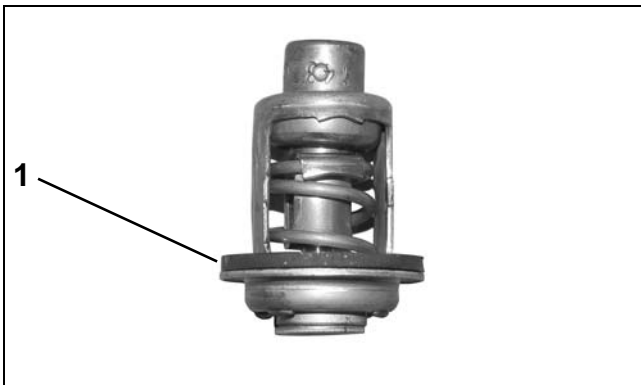

1. Thermostat seal

006401

Check thermostat for cracks, heat damage, or signs of corrosion. Check for proper operation. Thermostat opens at 143°F (62°C).

Refer to **THERMOSTAT AND PRESSURE RELIEF VALVE SERVICING** on p. 164.

#### Pressure Relief Valve Inspection

The pressure relief valve should be closed at IDLE speed. Water should not flow past the plunger and seal.

Start the outboard and check IDLE operating temperature.

If IDLE temperature is too low, check pressure relief valve plunger and seal for damage or debris that could prevent the valve from closing completely.

If IDLE temperature is still below operating range, replace pressure relief valve assembly and plunger seal.

To test pressure relief valve operation, monitor temperature at the thermostat housing with Temperature Gun, P/N 772018, or digital pyrometer.

Confirm normal IDLE operating temperature.

Slowly increase engine speed from IDLE, up through 3500 RPM.

Engine temperature should decrease from normal IDLE temperatures as pressure relief valve opens. Valve should open between 2800-3200 RPM.

If temperature decreases at a lower RPM, replace pressure relief valve assembly.

Refer to **THERMOSTAT AND PRESSURE RELIEF VALVE SERVICING** on p. 164.

## TEMPERATURE SENDER SERVICING

### Removal

Loosen sensor and remove by hand. Use care to avoid breaking threads.

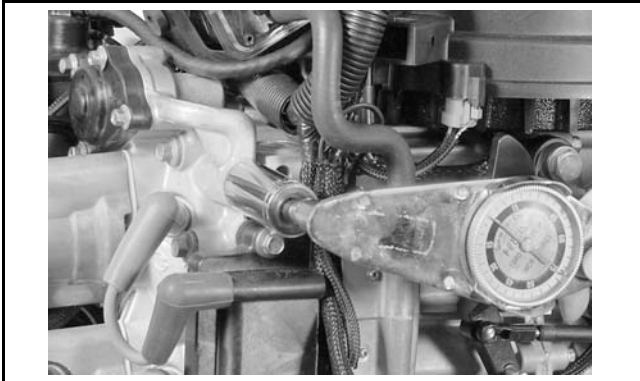

007375

Clean sensor threads, sensor, and sensor cavity.

### Installation

Fill bottom of sensor cavity with 0.7 cc of *Thermal Joint Compound*, P/N 322170. Sensor cavity should be filled to 1 inch (25 mm) below the top edge of the cavity.

Install sensor. DO NOT use gasket sealing compound. SLOWLY tighten temperature sensor to a torque of 50 to 70 in. lbs. (5.6 to 8.0 N·m).

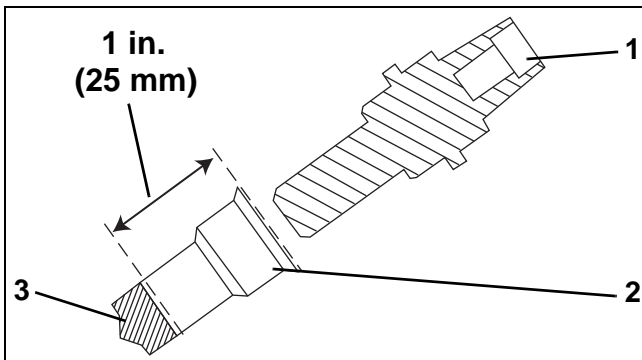

007049

1. Temperature sensor
2. Sensor cavity
3. Thermal joint compound

Wait 10 minutes for trapped air to bleed from cavity. Thermal compound may seep past threads. Retighten sensor.

## THERMOSTAT AND PRESSURE RELIEF VALVE SERVICING

The thermostat and pressure relief valve should be serviced at the same time.

### Disassembly

Remove four screws.

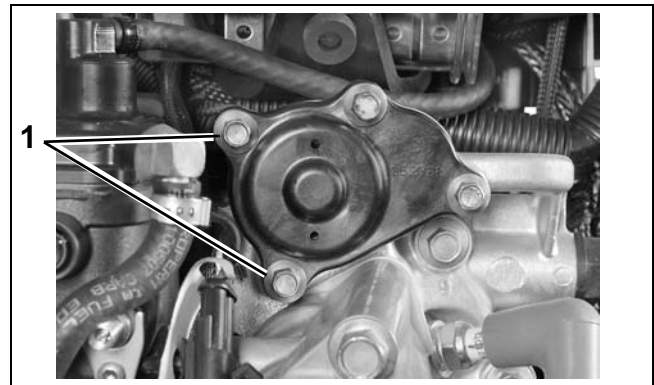

1. Screws

007376

Remove thermostat and pressure valve cover from cylinder head.

Remove pressure valve assembly.

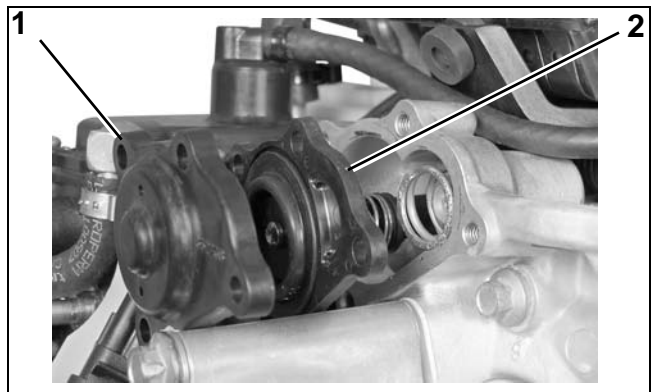

1. Thermostat and pressure valve cover
2. Pressure valve assembly

007377

Remove spring, thermostat, and gasket.

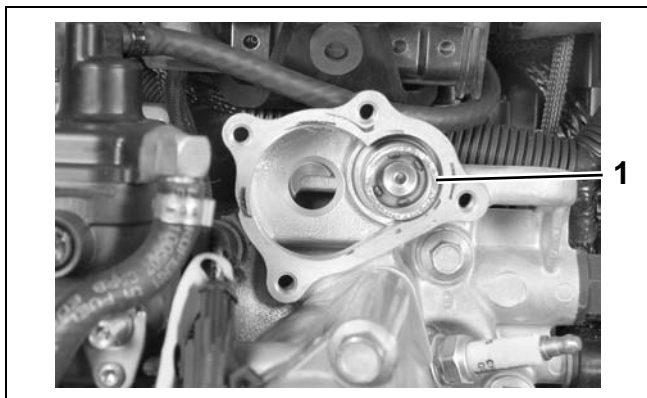

1. Spring, thermostat and gasket 007378

### Inspection

Inspect all parts for cracks, heat damage, or signs of corrosion. Replace damaged parts. Clean debris from housing and parts.

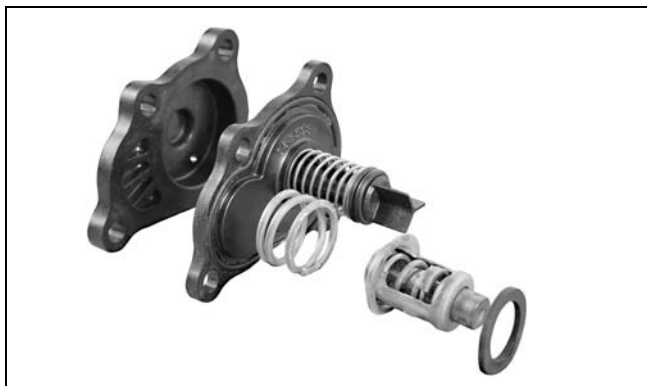

007379

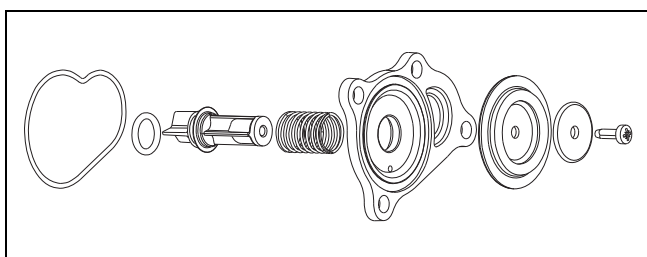

Pressure Relief Valve Assembly Components 007380

### Assembly

Assembly is the reverse of disassembly. Pay close attention when performing the following **additional** tasks.

Install a **new** plunger seal on plunger.

Apply a light coat of *Gasket Sealing Compound* to a **new** o-ring and place in groove in plate.

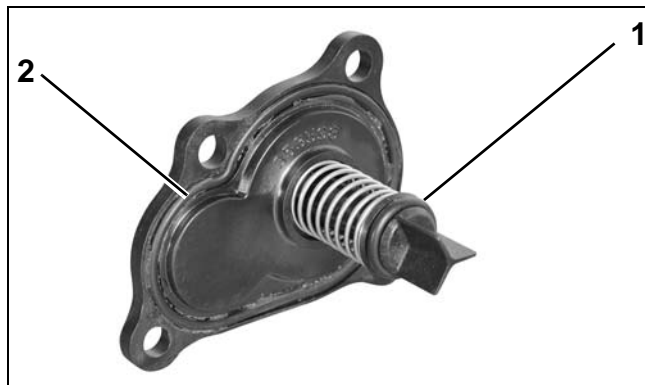

1. Plunger seal 007381  
2. Plate o-ring

Install thermostat gasket, thermostat and spring into thermostat housing.

Install pressure valve assembly into housing.

Apply *Nut Lock* to screw threads. Tighten screws to a torque of 84 to 106 in. lbs. (9.5 to 12 N·m).







# POWERHEAD

## TABLE OF CONTENTS

SERVICE CHART .....	168
COMPRESSION TESTING .....	170
POWERHEAD REMOVAL .....	170
POWERHEAD DISASSEMBLY .....	172
SYSTEMS REMOVAL .....	172
THROTTLE LINKAGE REMOVAL .....	173
SHIFT LINKAGE REMOVAL .....	173
CYLINDER HEAD REMOVAL .....	173
CRANKCASE DISASSEMBLY .....	173
CRANKSHAFT ASSEMBLY REMOVAL .....	174
CONNECTING RODS AND PISTONS .....	174
CRANKSHAFT SERVICE .....	175
CYLINDER BLOCK CLEANING .....	177
POWERHEAD INSPECTION .....	178
CYLINDER HEAD .....	178
BEARINGS .....	178
CYLINDER BORE .....	178
PISTONS .....	179
PISTON RINGS .....	179
POWERHEAD ASSEMBLY .....	179
CRANKSHAFT ASSEMBLY .....	179
PISTONS AND CONNECTING RODS .....	181
CRANKSHAFT ASSEMBLY INSTALLATION .....	182
CRANKCASE ASSEMBLY .....	183
CYLINDER HEAD INSTALLATION .....	184
MEGAPHONE AND INNER EXHAUST HOUSING INSTALLATION .....	185
SHIFT LINKAGE INSTALLATION .....	186
THROTTLE LINKAGE INSTALLATION .....	187
FINAL POWERHEAD ASSEMBLY .....	187
POWERHEAD INSTALLATION .....	188
POWERHEAD MOUNTING .....	188
SHIFT LINKAGE ADJUSTMENT .....	189
FINAL ADJUSTMENTS .....	190
POWERHEAD VIEWS .....	191
PORT ELECTRIC START MODELS .....	191
STARBOARD ELECTRIC START MODELS .....	191
PORT ROPE START MODELS .....	192
STARBOARD ROPE START MODELS .....	192
FRONT .....	193
REAR .....	194
TOP .....	195

**POWERHEAD  
SERVICE CHART**

**SERVICE CHART**

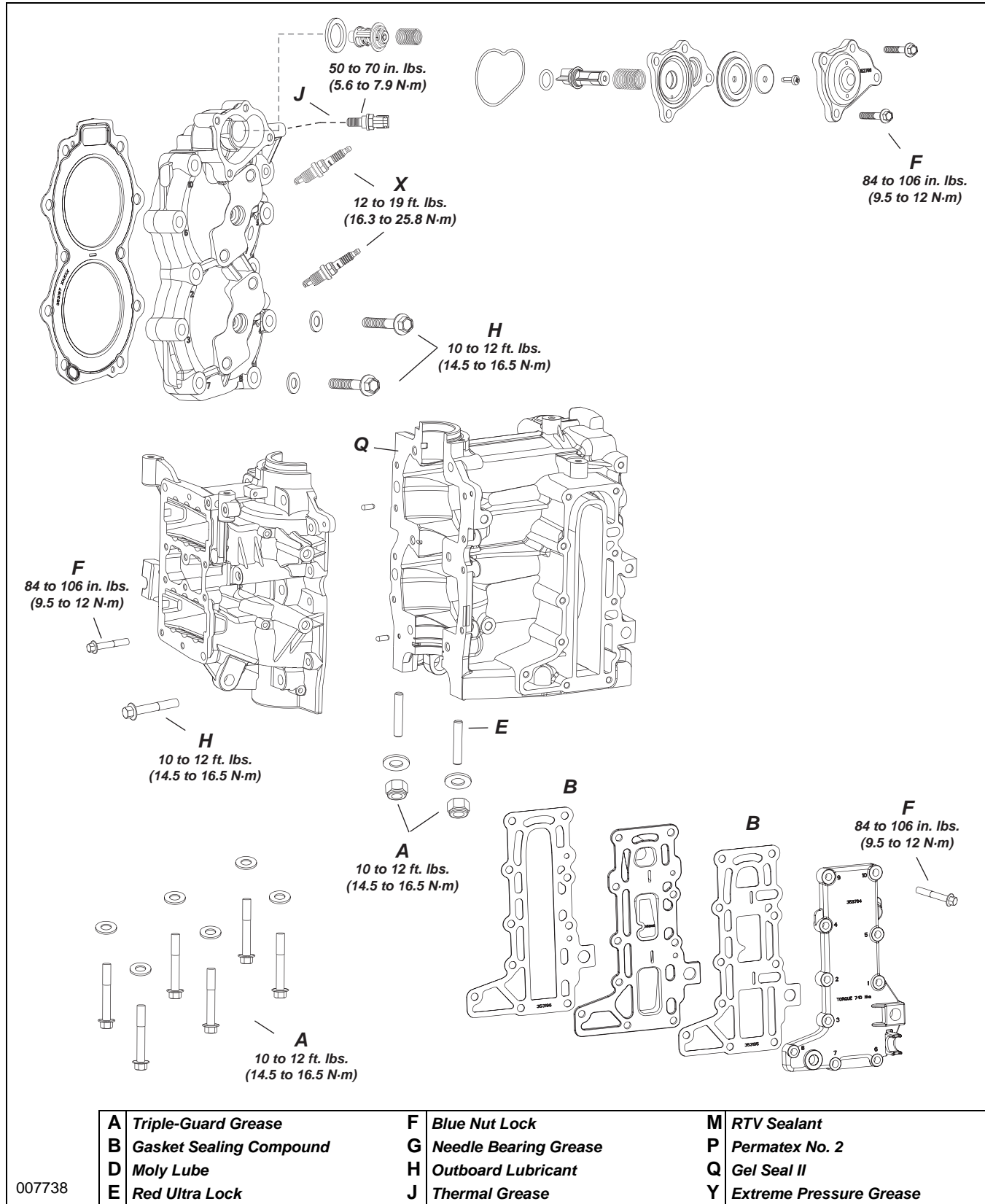

007738

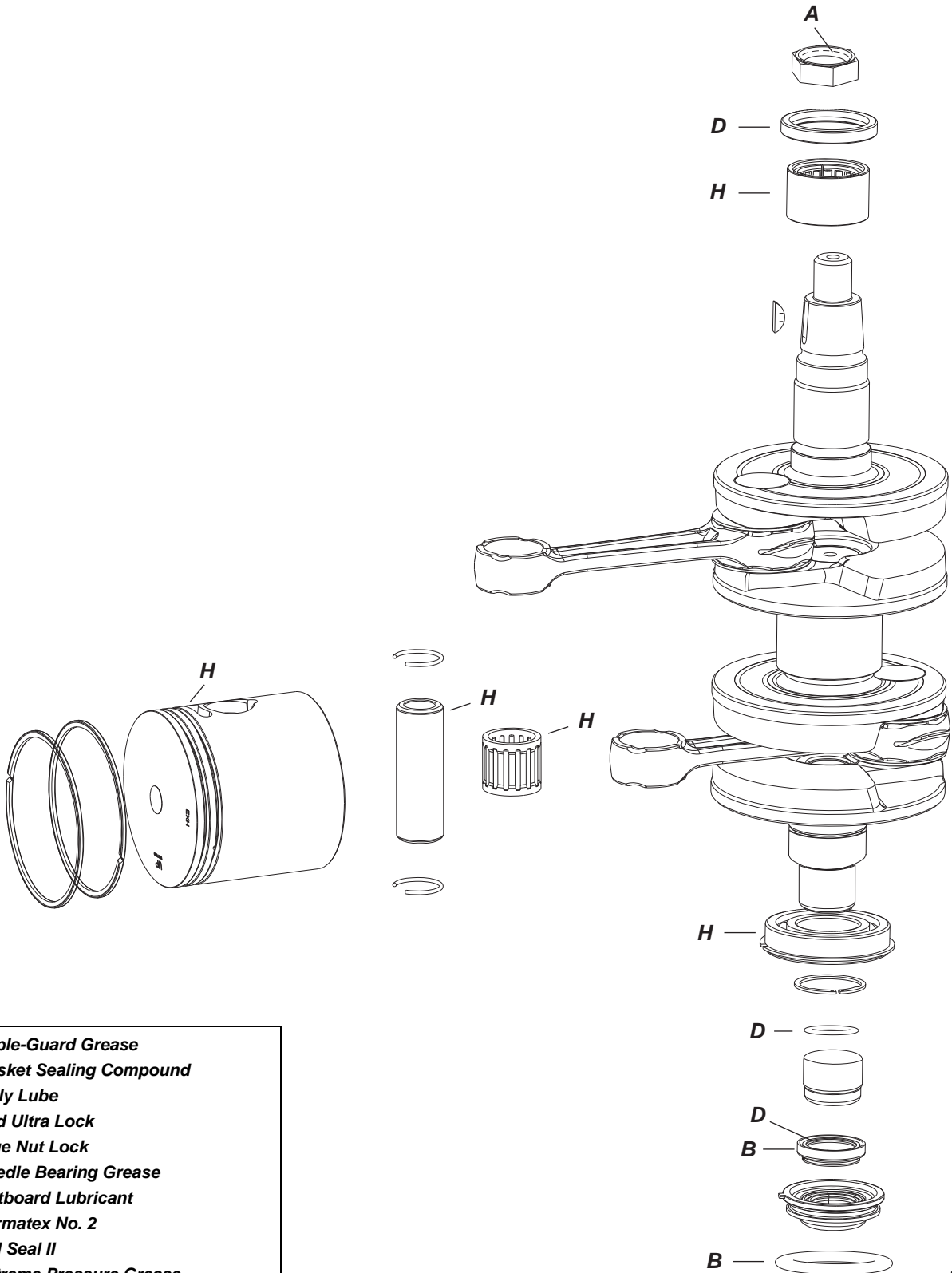

- A** Triple-Guard Grease
- B** Gasket Sealing Compound
- D** Moly Lube
- E** Red Ultra Lock
- F** Blue Nut Lock
- G** Needle Bearing Grease
- H** Outboard Lubricant
- P** Permatex No. 2
- Q** Gel Seal II
- Y** Extreme Pressure Grease

**10**

007739

## COMPRESSION TESTING

Start and run outboard until it achieves operating temperature, then shut OFF.

Disconnect crankshaft position sensor (CPS) connector. Remove all spark plugs.

Advance throttle linkage to WOT.

Install compression tester's hose attachment into spark plug hole (14 mm threads).

While cranking outboard with starter, note maximum pressure reading on gauge. Repeat procedure for each cylinder.

If engine shows a variation greater than 15 psi (100 kPa) between cylinders, check for:

- damaged cylinder head
- damaged pistons
- broken or stuck piston rings
- scored cylinder walls

Return throttle to idle position and reconnect CPS connector. Replace spark plugs. Refer to Spark Plug **Indexing** on p. 36.

## POWERHEAD REMOVAL

### **WARNING**

**Protect against hazardous fuel spray. Before starting any fuel system service, carefully relieve fuel system pressure. Refer to Relieving Fuel System Pressure on p. 130.**

**To prevent accidental starting while servicing, twist and remove spark plug leads.**

Remove lower motor covers. **Lower Cover Removal** on p. 45.

Remove the recoil starter housing. Refer to **RECOIL STARTER REMOVAL** on p. 281.

Remove exhaust relief muffler. Refer to **Exhaust Relief Muffler** on p. 206.

Disconnect power trim connectors.

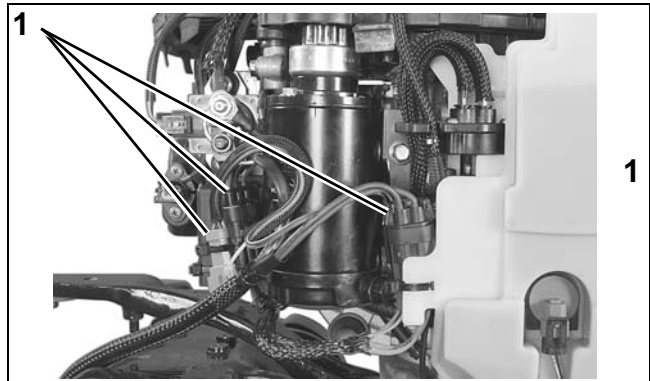

1. Connectors

007784

## POWERHEAD POWERHEAD REMOVAL

Remove water intake screens.

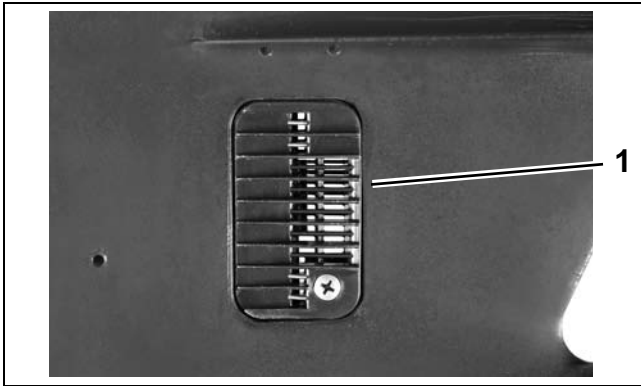

1. Water intake screen

007649

Remove the upper shift rod connector screw.

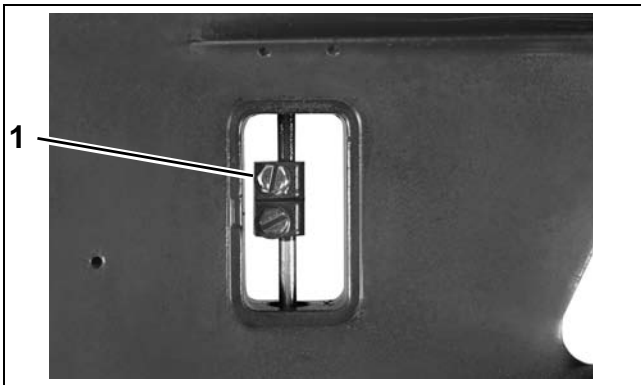

1. Shift rod connector screw

007650

Install Universal Puller Set, P/N 378103 and Lifting Eye, P/N 321537, on flywheel and seat the three screws completely.

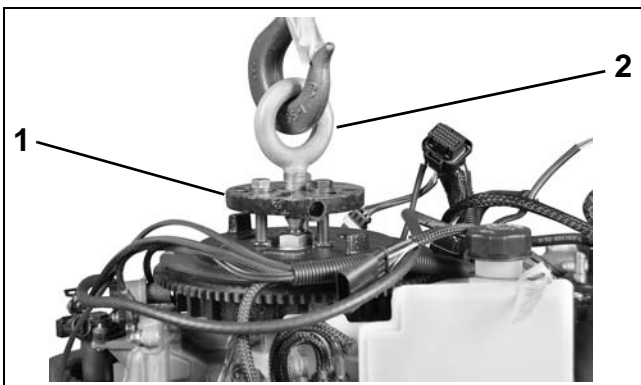

1. Universal puller set  
2. Lifting eye

007740

Fasten appropriate chain hook to eye of tool and support weight of powerhead with hoist.

Remove the two exhaust housing to powerhead nuts and six exhaust housing to powerhead screws.

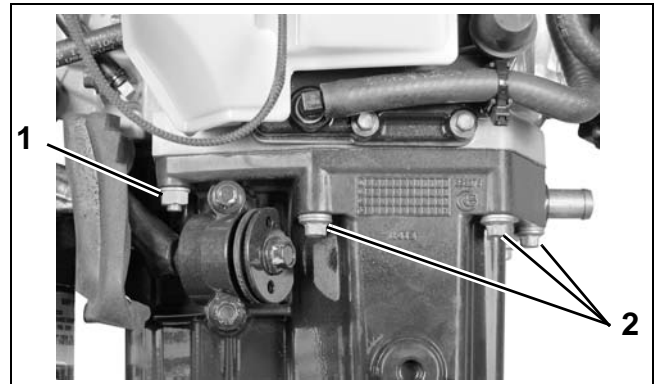

1. Powerhead nuts  
1. Powerhead screws

007741

Use a suitable tool to carefully separate the powerhead from exhaust housing.

**IMPORTANT:** Do not damage the powerhead or exhaust housing mating surfaces.

Remove clip from upper shift rod and remove shift rod.

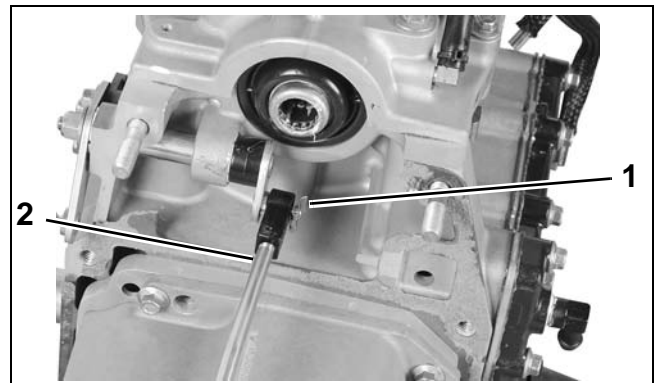

1. Clip  
2. Shift shaft

007742

## POWERHEAD POWERHEAD DISASSEMBLY

Remove five inner exhaust housing screws and inner exhaust housing.

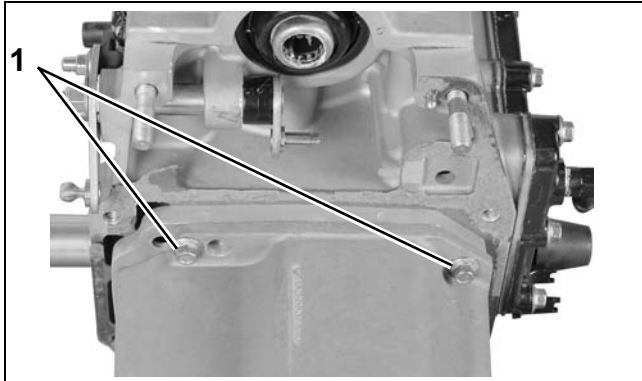

1. Screws

007743

Remove three exhaust megaphone screws and exhaust megaphone.

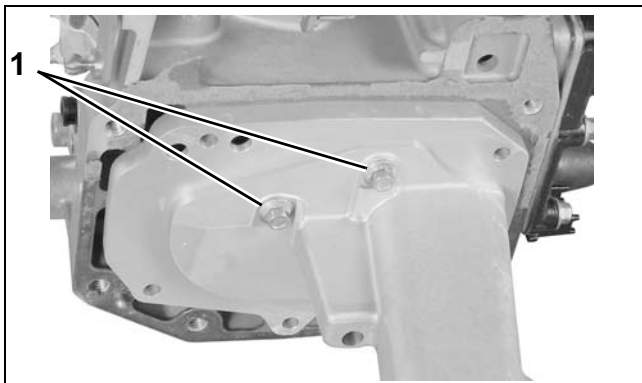

1. Screws

007744

## POWERHEAD DISASSEMBLY

### Systems Removal

To simplify reassembly and wiring installation, lay out the various screws and clamps in the order of their proper location.

Remove the oil tank. Refer to **Oil Tank Assembly** on p. 155.

Remove fuel pump assemblies, filter and fuel injectors. Refer to **FUEL COMPONENT SERVICING** on p. 130.

**IMPORTANT:** Mark injectors for cylinder location before removal. All injectors must be installed in their original location. Improper injector installation can result in powerhead failure.

Remove ignition coils.

Remove the electric starter. Refer to **Starter Removal** on p. 107.

Remove **EMM** and electrical harness assembly. Refer to **EMM SERVICING** on p. 66.

Remove flywheel and stator. Refer to **FLYWHEEL AND STATOR SERVICING** on p. 103.

Remove throttle linkage. Refer to **Throttle Linkage Removal** on p. 173.

Remove shift linkage. Refer to **Shift Linkage Removal** on p. 173.

Remove the throttle body and reed plate assemblies. Refer to **Intake Manifold Service** on p. 138.

Remove thermostat and pressure valve assembly. Refer to **THERMOSTAT AND PRESSURE RELIEF VALVE SERVICING** on p. 164.

Remove oil supply and recirculation hoses.

## Throttle Linkage Removal

Remove throttle cam and throttle lever.

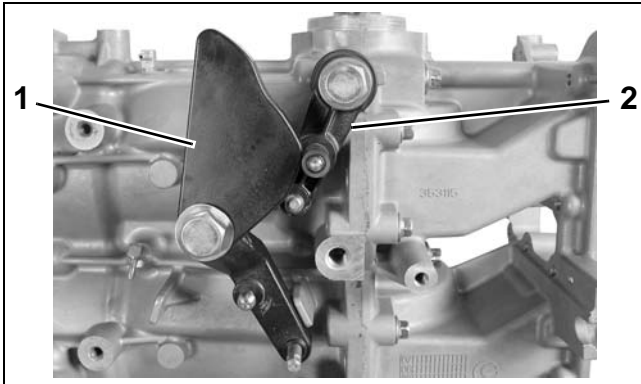

1. Throttle cam
  2. Throttle lever
- 007785

## Shift Linkage Removal

Remove nut from shift lever. Remove shift lever and shaft assembly.

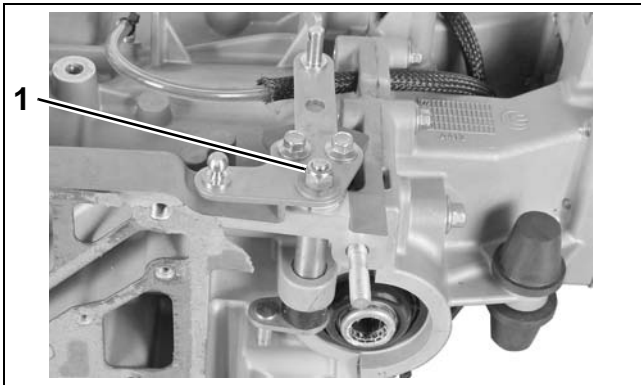

1. Nut
- 007745

Remove the ball, guide, and spring of the shift detent assembly from the crankcase.

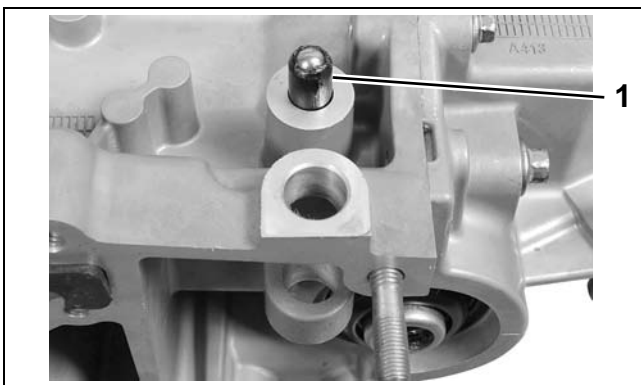

1. Shift detent assembly
- 007786

## Cylinder Head Removal

Loosen in stages and remove cylinder head retaining screws. Remove the cylinder head. Discard cylinder head gasket.

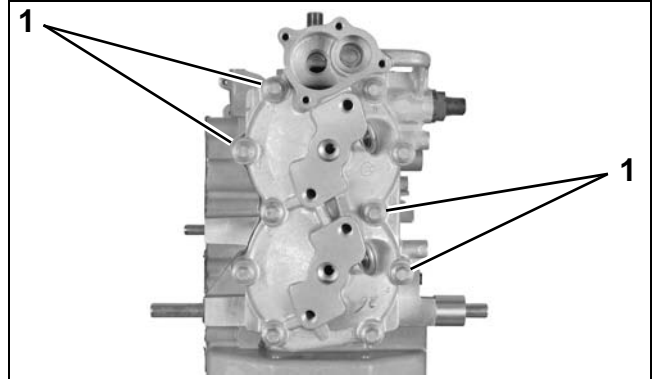

1. Cylinder head screws (10 total)
- 007746

## Crankcase Disassembly

Remove screws and exhaust side water covers.

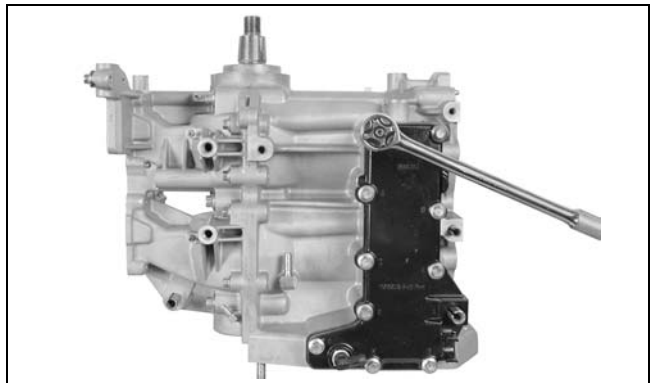

007747

**IMPORTANT:** Use care to avoid bending or damaging inner exhaust side cover.

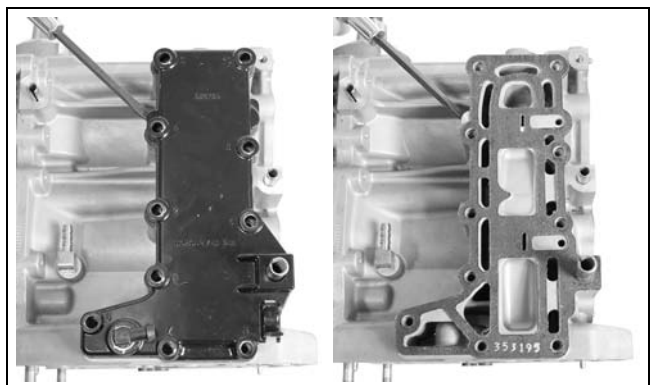

007787  
007788

## POWERHEAD POWERHEAD DISASSEMBLY

Remove crankcase flange screws. Loosen in **stages** and remove the main bearing screws.

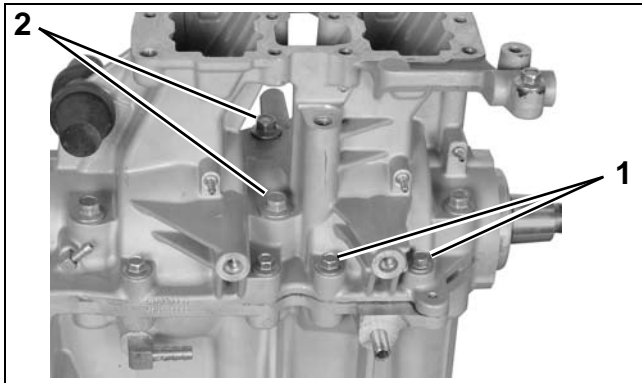

1. Flange screws
2. Main bearing screws

007748

Separate crankcase and cylinder block. It may be necessary to tap on crankshaft with a rawhide or rubber mallet to loosen.

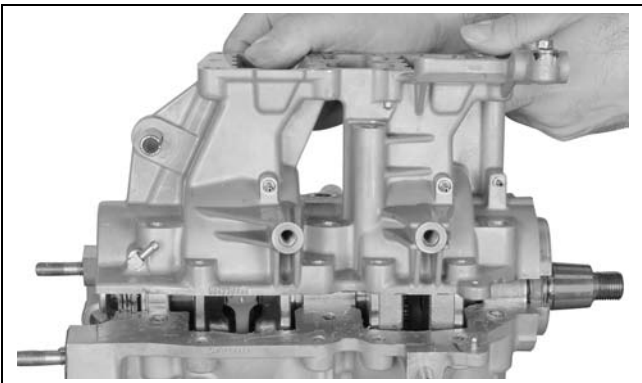

007749

### Crankshaft Assembly Removal

Carefully lift crankshaft straight up and remove from crankcase.

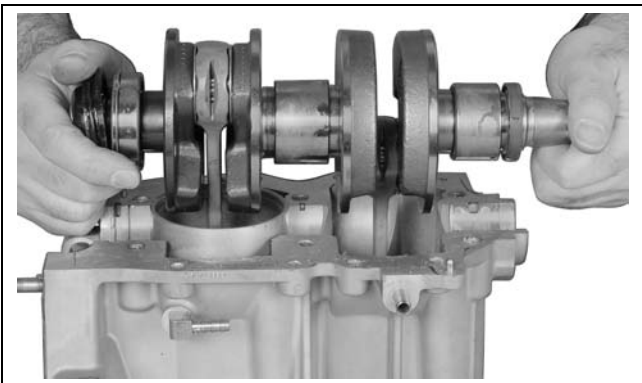

007750

### Connecting Rods and Pistons

Use an appropriate ring expander to remove all piston rings from pistons. Discard the rings.

#### **WARNING**

**Wear safety glasses to avoid injury.**



007751

Remove wrist pin retaining rings. Discard retaining rings.

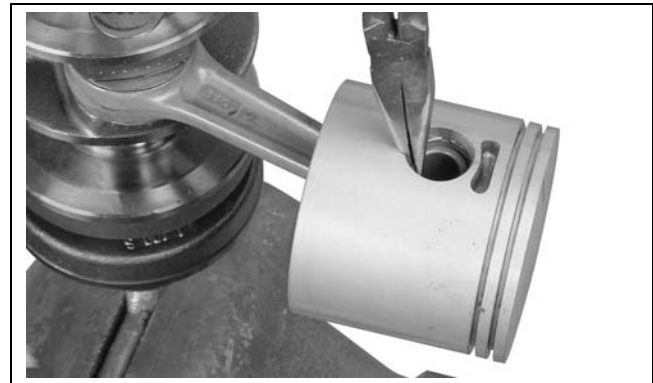

007752

The wrist pin fit is loose on both sides. Push the wrist pin through to free the piston from the con-



necting rod. If necessary, use Wrist Pin Pressing Tool, P/N 326356, to remove the wrist pin.



007753

**Crankshaft Service**

Remove upper seal from crankshaft. Discard the seal. A new upper seal must be installed on assembly.

Remove the upper main bearing.

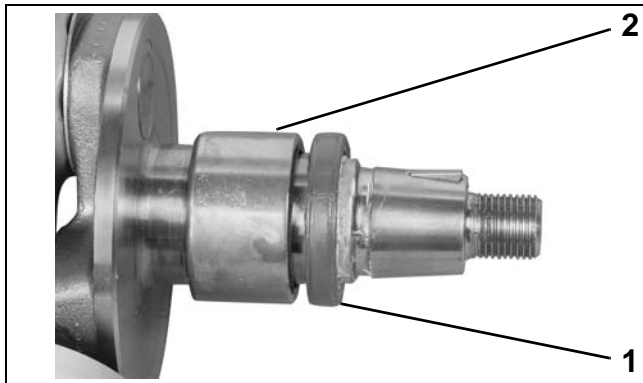

- 1. Upper oil seal
- 2. Upper main bearing

007754

Remove the lower bearing seal housing.



007755

Remove the housing O-ring. Discard O-ring.



007789

Use a punch to remove the housing seal. Discard seal.



- 1. Punch

007790

## POWERHEAD

### POWERHEAD DISASSEMBLY

Inspect housing and replace if necessary.

Remove the O-ring from crankshaft sleeve and inspect it. Replace the O-ring if it is not in good condition.

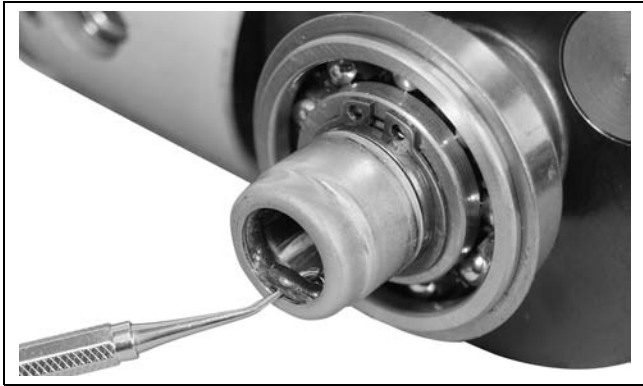

007791

Inspect the crankshaft sleeve and replace if necessary. To remove the sleeve, use Slide Hammer, P/N 432128, and Puller Jaws, P/N 432130.

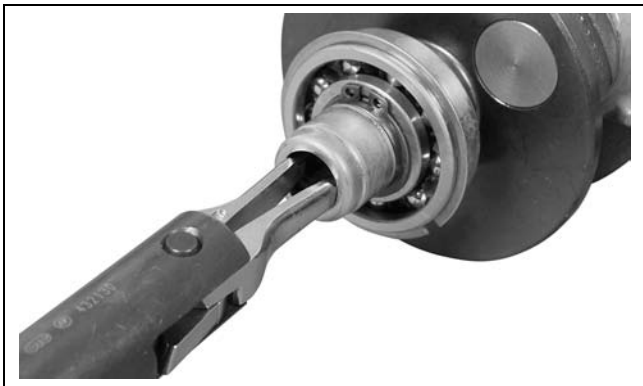

007792

Remove the lower main bearing only if it needs to be replaced. Use external retaining ring pliers to remove the lower bearing retaining ring.



007756

**IMPORTANT:** If the lower main bearing is removed from the crankshaft, it must be discarded. DO NOT reuse it.

Use a bearing separator to support the bearing, and press off the crankshaft.

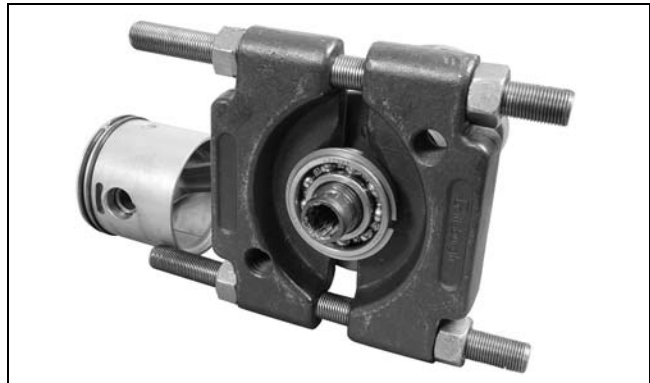

007793

# CYLINDER BLOCK CLEANING

**IMPORTANT:** Before inspecting or assembling powerhead, all internal components must be completely clean and free of contaminants. Be careful to avoid damaging any machined surfaces.

Remove any carbon accumulation from exhaust port areas.

Remove any carbon accumulation from cylinder head combustion chambers.

If cylinder walls are glazed from extended use, use a rigid, medium grit cylinder hone to resurface walls. Use slow RPM for best oil retention and ring sealing. When finished, a cross hatch pattern of 22 to 32° should be visible in the cylinder wall. The pattern should be uniform in both directions.

**IMPORTANT:** To avoid piston or cylinder block damage, restore the chamfer to all port edges using a ball hone or other suitable tool.

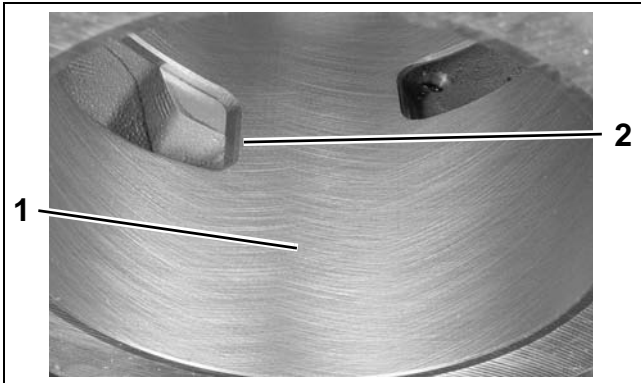

1. Crosshatch pattern in cylinder wall  
2. Chamfered port edge  
002067

Use *Gel Seal and Gasket Remover* to remove all traces of gaskets, adhesives, and *Gel-Seal II™*

sealant from the cylinder block, crankcase, cylinder head, and water cover.

## ⚠ WARNING

To avoid personal injury, wear eye protection and rubber gloves when using *Gel Seal and Gasket Remover*.

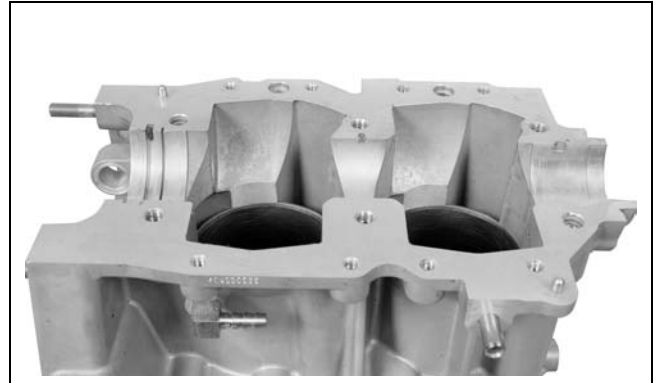

007794

Carefully remove any carbon accumulation from the tops and ring grooves of the piston using *Engine Tuner*. A ring groove cleaning tool can be made by breaking an old ring and grinding an angle on its end. Do not damage ring grooves while cleaning.

Thoroughly wash entire cylinder block and crankcase with warm, soapy water to remove all traces of contaminants.

Air dry cylinder block and crankcase. Blow all holes and passageways with compressed air.

## ⚠ WARNING

To avoid personal injury, wear eye protection and set compressed air pressure at less than 25 psi (172 kPa).

Cover the cylinder walls with a liberal amount of outboard lubricant to prevent corrosion.

# POWERHEAD INSPECTION

For dimensions, refer to **SERVICE SPECIFICATIONS** on p. 10.

**IMPORTANT:** Before any inspection process can begin, all internal components must be completely clean and free of contaminants.

Visually inspect all parts. Check for unusual wear patterns, scuffing, or deterioration of aluminum parts, heat-related discoloration of bearings and bearing surfaces, and broken components.

## Cylinder Head

Check for cylinder head warpage using a piece of bar stock or machinist's straightedge and a feeler gauge set.

Cylinder head warpage must not exceed 0.006 in. (0.15 mm) per inch of measurement. Replace head if warpage exceeds this dimension.

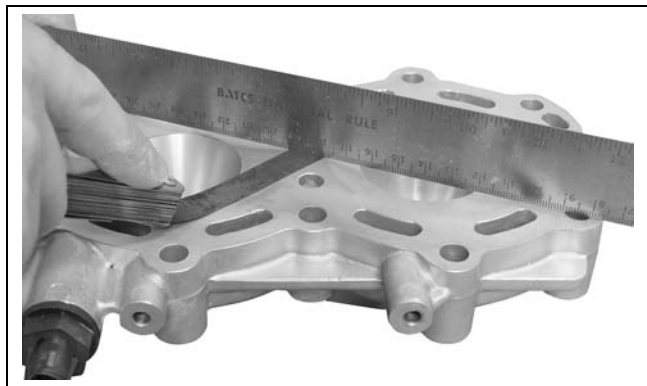

007757

Check fuel deflector pins for damage.

## Bearings

Inspect upper and lower main bearings for excess wear, nicks, or scratches. Replace if necessary.

## Cylinder Bore

Use a Cylinder Bore Gauge to inspect each cylinder bore for an out-of-round, oversize, or tapered condition. Be sure the gauge is perfectly square in the bore when measuring.

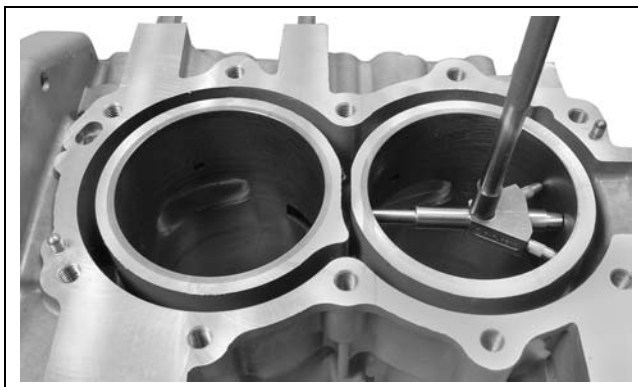

TYPICAL

007758

Measure each cylinder in at least two areas. Each area should be measured twice. The difference between the two measurements in each area is the cylinder out-of-round dimension.

- The cylinder must not be out-of-round by more than 0.004 in. (0.10 mm).

The dimensional difference between the two areas is cylinder taper.

- The cylinder taper must not exceed 0.002 in. (0.05 mm).

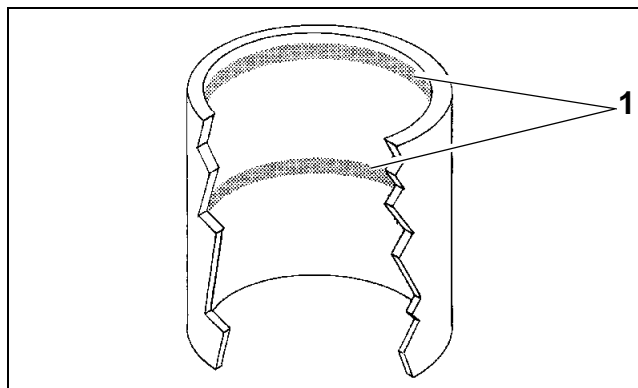

1. Measurement areas

DR3482

The difference between the measurements and standard bore is cylinder oversize. For dimensions, refer to **SERVICE SPECIFICATIONS** on p. 10.

- The cylinder must not be oversized by more than 0.003 in. (0.08 mm).

## Pistons

Visually inspect pistons for signs of abnormal wear, scuffing, cracks, or burning.

## Piston Rings

For new ring sets, place each ring separately in its respective bore. Use a piston to square the ring in the cylinder. Use a feeler gauge to measure the ring end gap.



007759

Ring end gap should be:

- 0.011 to 0.019 in. (0.30 to 0.50 mm)

**IMPORTANT:** Ring end gap increases approximately 0.003 in. (0.076 mm) for each 0.001 in. (0.025 mm) increase in cylinder bore diameter. DO NOT exceed cylinder oversize dimension.

Use a machinist's straightedge to check for proper ring clearance. Position piston rings on piston. Push rings into groove and hold straightedge against the side of the piston. Rings must be even or just below the surface of piston. Rings must move freely in piston ring groove.

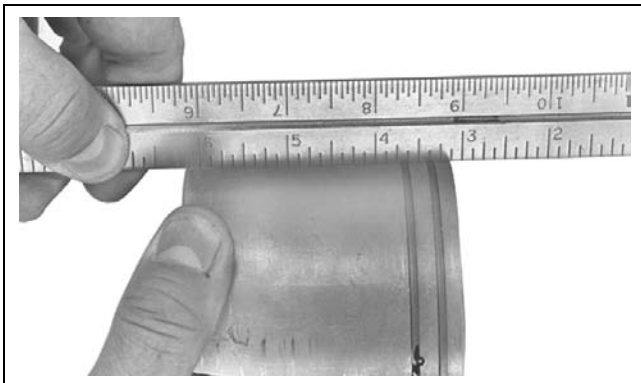

31796

# POWERHEAD ASSEMBLY

**IMPORTANT:** Proceed slowly. Make no forced assemblies unless a pressing operation is called for. All internal components must be perfectly clean and lightly coated with outboard lubricant.

**IMPORTANT:** Use new wrist pin retaining rings, gaskets, seals, and O-rings during assembly.

## Crankshaft Assembly

Oil the end of the crankshaft. Use Crankshaft Bearing/Sleeve Installer, P/N 339749, and place a new lower main bearing onto crankshaft with lettered side facing the tool. Install bearing until it seats on the crankshaft.

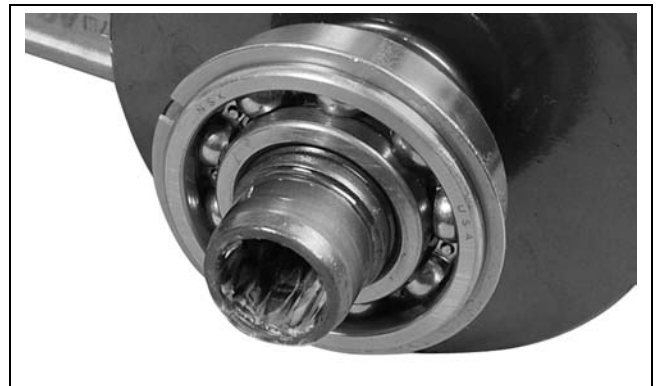

007795

Oil the end of the crankshaft. Use Crankshaft Bearing/Sleeve Installer, P/N 339749, to drive a new sleeve onto the crankshaft until the installer contacts the lower main bearing.

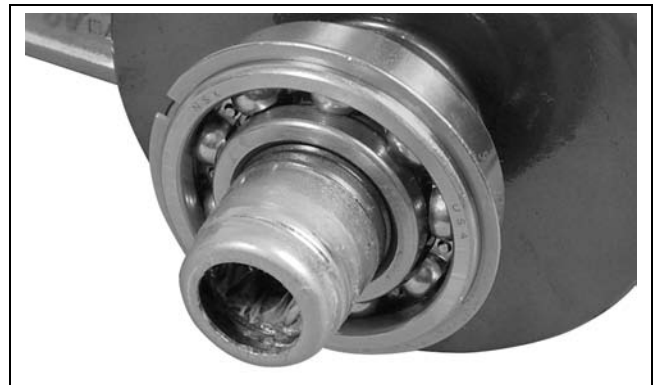

007796

## POWERHEAD POWERHEAD ASSEMBLY

If the installer sticks on the sleeve after installation, thread Slide Hammer, P/N 391008, into installer and pull it off.

**IMPORTANT:** Inspect sleeve after installation. Sleeve must not be used if surface is damaged.

Use retaining ring pliers to install bearing retaining ring with sharp edge facing away from bearing.

Lubricate a new driveshaft O-ring and lightly lubricate crankshaft splines with *Moly Lube*. Install O-ring in sleeve.

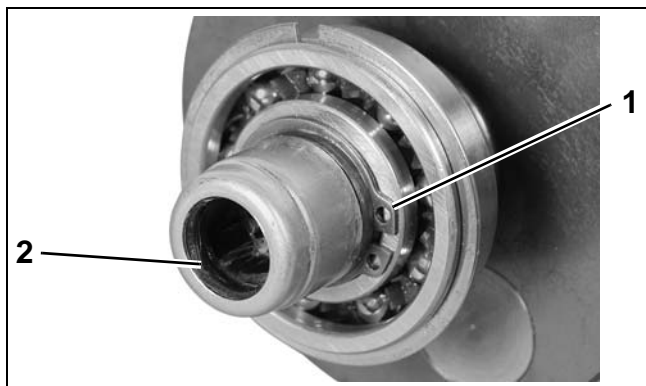

1. Bearing retaining ring  
2. O-ring  
007797

Lightly coat the outside edge of a new lower housing seal with *Gasket Sealing Compound*. Press against outer case of the seal to install seal in the lower housing with extended lip facing down. Lubricate seal lip with *Moly Lube*.

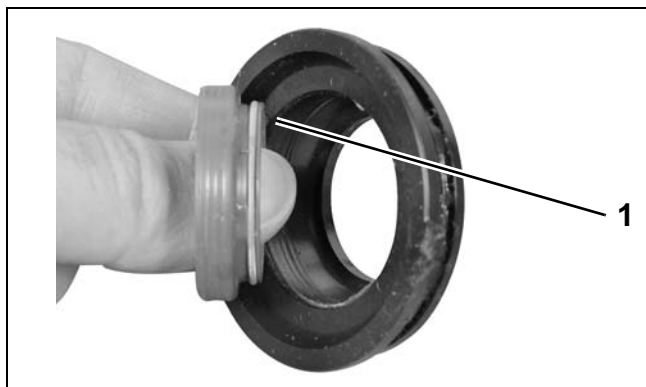

1. Seal lip  
007798

Install a new O-ring on the lower housing. Before installing crankshaft into cylinder block, apply a thin coat of *Gasket Sealing Compound* to outer edge of O-ring.

Place lower seal housing on crankshaft.

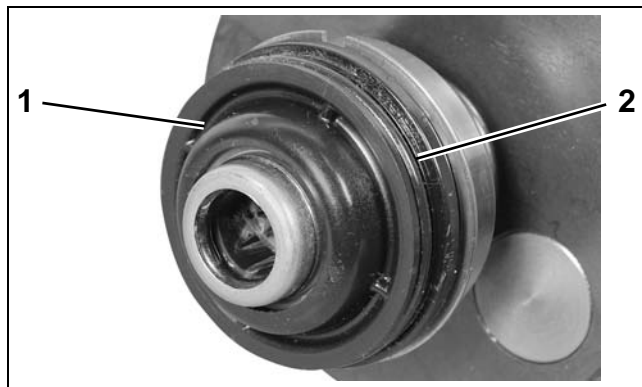

1. Lower seal housing  
2. O-ring  
007799

Lubricate upper main bearing with outboard lubricant and install on crankshaft.

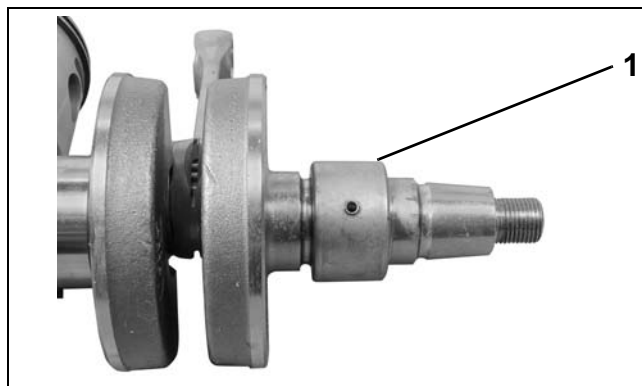

1. Upper main bearing  
007760

Pack lip of upper oil seal with *Moly Lube*. Place seal on crankshaft with lip toward driveshaft and

enclosed face toward flywheel. Do not apply sealer to outside edge of the seal.

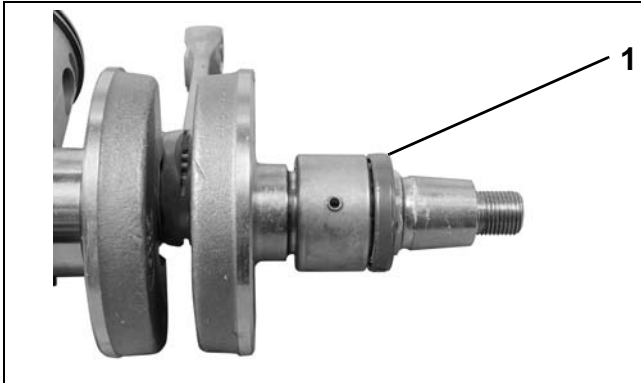

1. Upper oil seal

007761

## Pistons and Connecting Rods

**NOTICE** It is very important that the pistons in this engine are installed in the correct location and direction. Engine damage will occur if installed incorrectly.

New pistons are stamped "UP." This marking should be turned toward the top of the crankshaft.



1. Stamped marking

007800

Apply outboard lubricant to the wrist pin bearings, wrist pin and wrist pin bore. Install the bearings in the small end of the connecting rod.

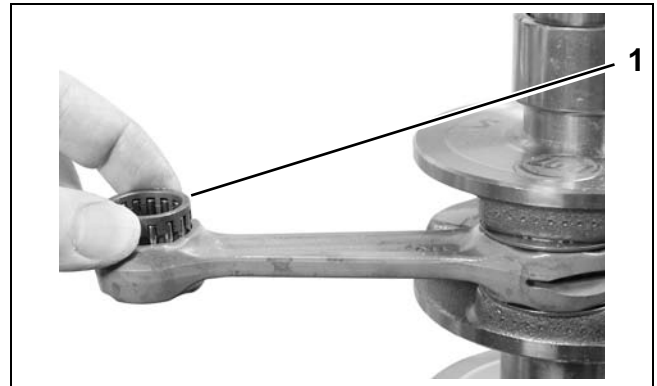

1. Wrist pin bearings

007762

Place the piston over the connecting rod and bearings.

Install wrist pin through piston and connecting rod.

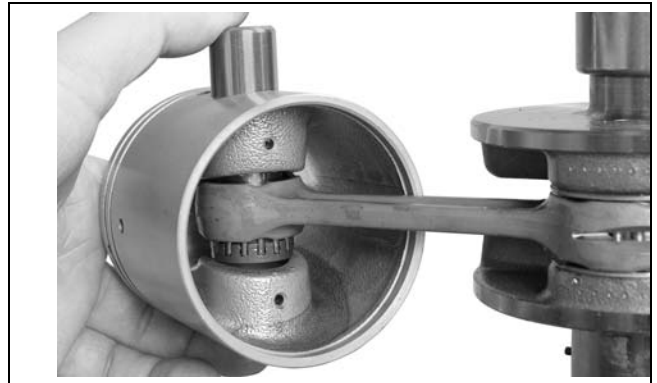

007763

Use Wrist Pin Retainer Installation Tool, P/N 354720, to install new wrist pin retaining rings in each wrist pin hole. Place one retaining ring into tool base. Insert driver into base and through retaining ring. Align tool on piston. Support piston

## POWERHEAD POWERHEAD ASSEMBLY

and tool. To seat retaining ring, swiftly strike the driver.



007764

Gap of retaining ring faces up, away from notch in piston.

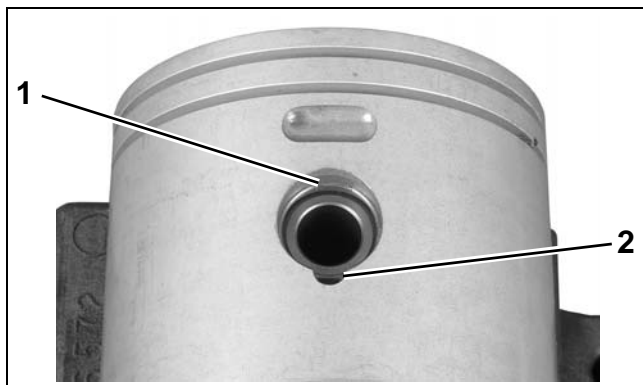

1. Gap of retaining ring
2. Notch in piston

002050

### Installing Pistons

When all pistons and connecting rods are assembled, install piston ring sets. Be sure rings are installed in the cylinder used to test ring end gap. Refer to **POWERHEAD INSPECTION** on p. 178.

**IMPORTANT:** Be sure gap of ring fits squarely around dowel pin.

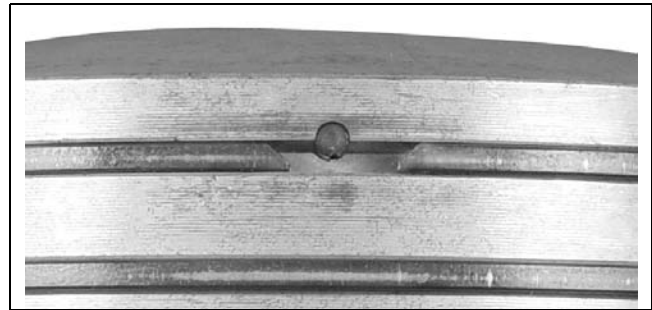

002048

**IMPORTANT:** Before continuing, make sure that all *Gel-Seal II* has been removed from the cylinder block and crankcase mating flanges. If traces of hardened *Gel-Seal II* are left, main bearings could be misaligned. Refer to **CYLINDER BLOCK CLEANING** on p. 177.

### Crankshaft Assembly Installation

Rotate cylinder block so crankcase mating flange is facing up.

Apply *Gasket Sealing Compound* to lower oil seal groove in cylinder block. **DO NOT** put any sealer in upper seal groove.

Coat pistons, rings and cylinder walls with out-board lubricant.

Locate piston rings on dowel pins.

Carefully lower crankshaft assembly into the cylinder block.

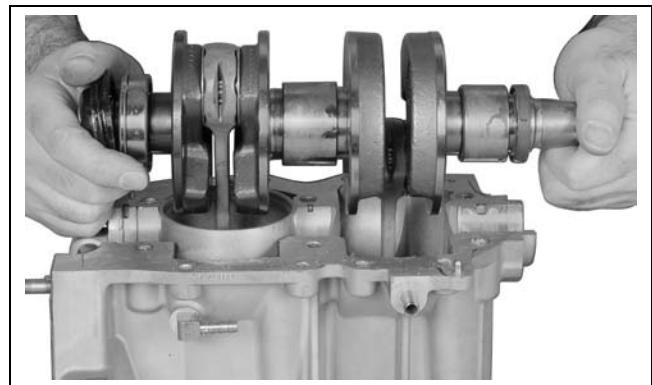

007750



- Align tab on lower bearing seal housing with slot in crankcase.
- Align upper oil seal in groove.
- Locate center and upper main bearing dowel pin with slot in crankcase.

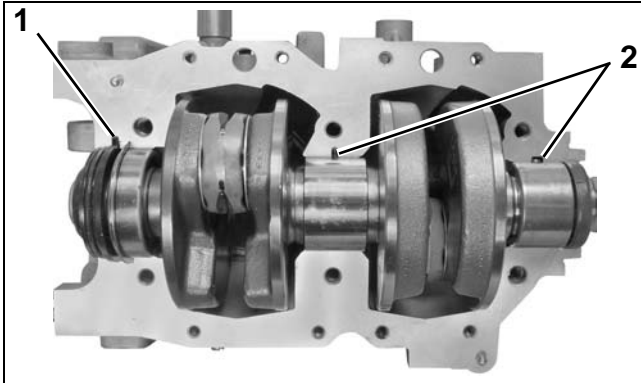

1. Lower bearing seal housing tab and slot  
2. Center and upper main bearing dowel pin and slots  
007765

## Crankcase Assembly

Thoroughly clean and degrease the mating flanges of the crankcase and cylinder block with a non-petroleum based solvent, such as isopropyl alcohol or acetone, and let air dry.

**IMPORTANT:** DO NOT allow solvent to get on internal components. Clean only the mating flanges.

Apply *Gasket Sealing Compound* to lower oil seal groove in crankcase. DO NOT put any sealer in upper seal groove.

Use a small brush with a tapping motion to apply a thin, even coat of *Gel-Seal II* sealant to the crankcase mating flange. The sealer must not come within 1/4 in. (6.4 mm) of bearings.

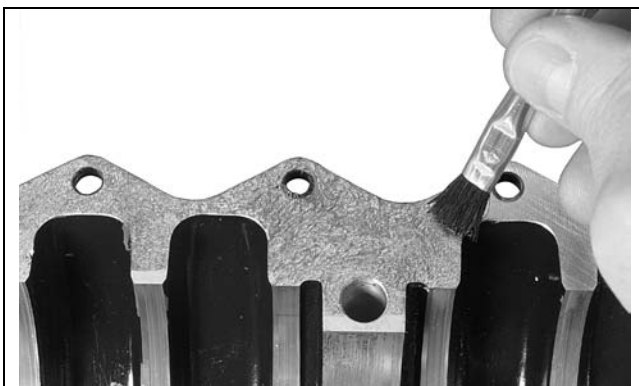

TYPICAL  
003874

**IMPORTANT:** *Gel-Seal II* has a shelf life of at least one year when stored at room temperature. Test the *Gel-Seal II* or replace it if the age of the tube cannot be determined. Using old *Gel-Seal II* could cause crankcase air leaks.

**IMPORTANT:** The use of *Locquic Primer* is NOT recommended. If primer is used, crankcase halves must be assembled and tightened within ten minutes after the *Gel-Seal II* has been applied.

Lower the crankcase into place. Make sure that upper oil seal and lower seal housing are seated in grooves.

Apply outboard lubricant to the main bearing screws. Tighten main bearing screws **in stages** to a final torque of:

- 10 to 12 ft. lbs. (14.5 to 16.5 N·m).

Start in the center and work outward in a spiral pattern.

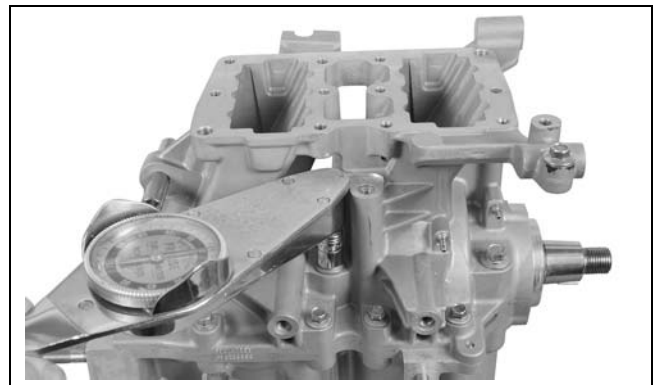

007766

Apply *Nut Lock* to crankcase flange screws. Install crankcase flange screws and tighten to a torque of 84 to 106 in. lbs. (9.5 to 12 N·m).

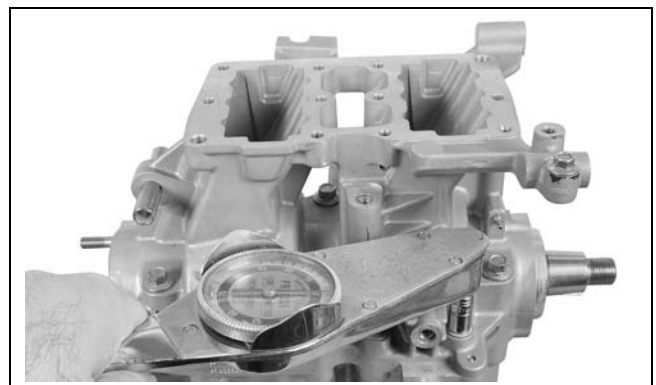

007767

## POWERHEAD POWERHEAD ASSEMBLY

Test that the crankshaft spins freely without binding.

**IMPORTANT:** After powerhead has been assembled, allow at least two hours for *Gel-Seal II* to cure before running outboard.

Apply *Gasket Sealing Compound* to both sides of new inner and outer exhaust cover gaskets. Position gaskets and covers on cylinder block.

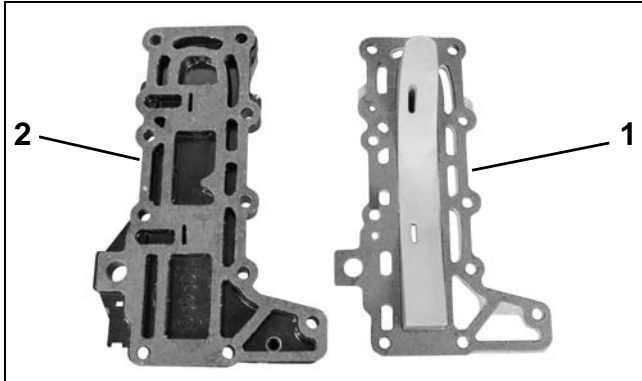

1. Inner exhaust cover  
2. Outer exhaust cover

007768

Apply *Nut Lock* to cover screws. Tighten all screws in sequence, to a torque of 84 to 106 in. lbs. (9.5 to 12 N·m).

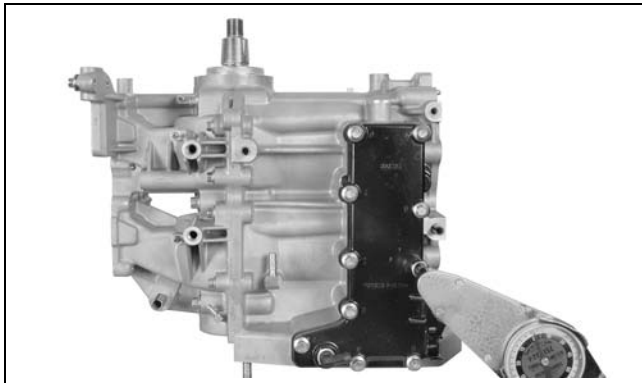

007769

## Cylinder Head Installation

Apply soapy water to water dam and insert into block.

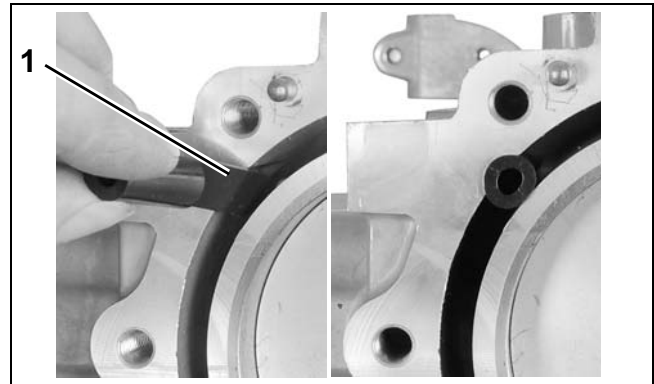

1. Water dam tab

007770

007771

Place a new cylinder head gasket on alignment pins.

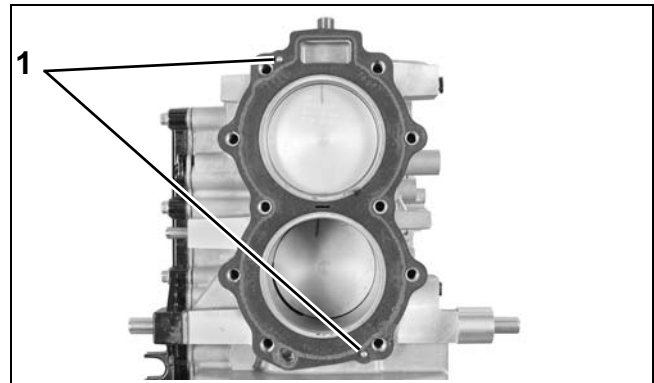

1. Alignment pins

007772

Install cylinder head with the thermostat toward the top. Apply *Triple-Guard* grease to the threads and install the cylinder head screws. DO NOT use any sealant on threads

Following sequence on cylinder head, tighten all screws in stages to a torque of 10 to 12 ft. lbs. (14.5 to 16.5 N·m)

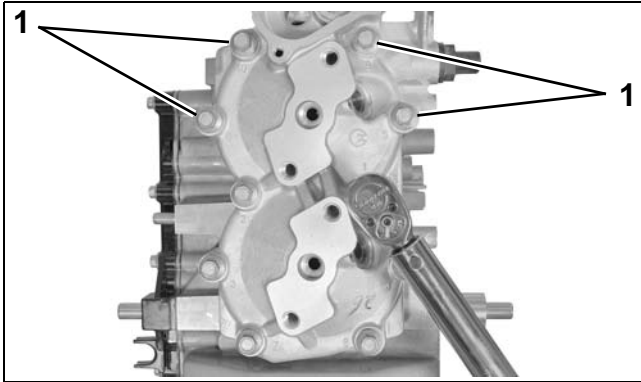

1. Cylinder head screws (10 total) 007773

### Megaphone and Inner Exhaust Housing Installation

Install water plug in cylinder block as shown.

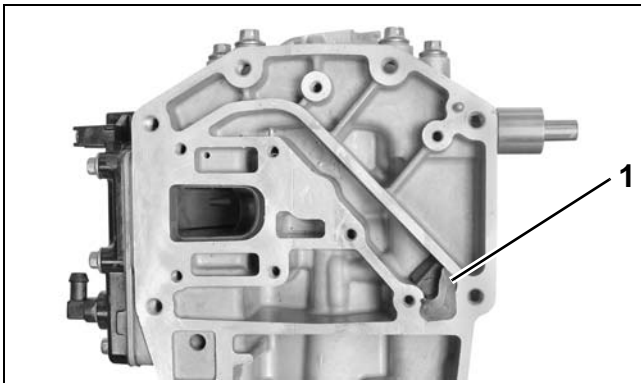

1. Water plug 007775

Place a new gasket on the powerhead. Apply *Nut Lock* to screws. Install exhaust megaphone and

secure with three screws. Tighten screws to a torque of 84 to 106 in. lbs. (9.5 to 12 N·m).

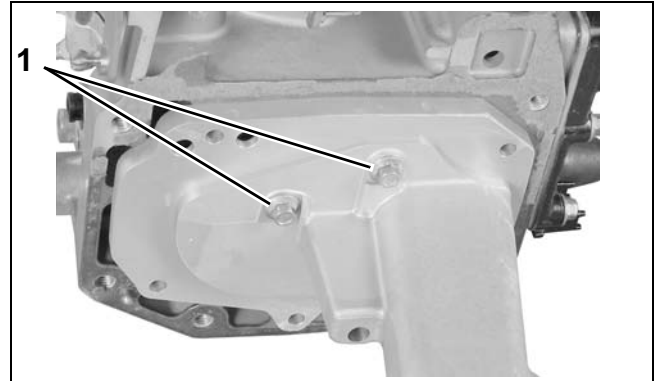

1. Screws 007744

Apply *Nut Lock* to screws. Install inner exhaust housing and secure with five screws. Tighten screws to a torque of 84 to 106 in. lbs. (9.5 to 12 N·m).

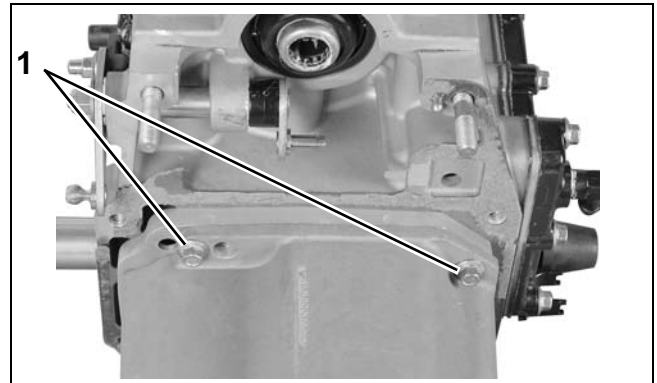

1. Screws 007743

# POWERHEAD

## POWERHEAD ASSEMBLY

### Shift Linkage Installation

Place the spring, guide, and ball of the shift detent assembly into the crankcase. Lubricate with *Triple-Guard* grease.

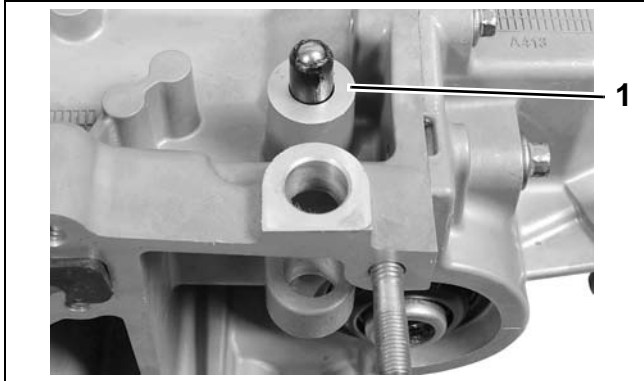

1. Shift detent assembly 007786

Lubricate shift linkage bosses at the base of the cylinder block with *Triple-Guard* grease. Insert bushings into bosses.

Apply *Triple-Guard* grease to the shift lever and shaft assembly. Guide shaft through bushings in crankcase.

**IMPORTANT:** Shift lever and shaft must be positioned with pin toward the rear of the cylinder block.

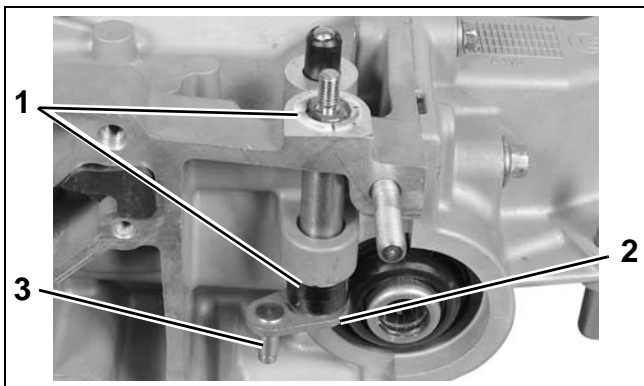

1. Bushings  
2. Shift lever and shaft assembly  
3. Pin 007801

Install shift lever and detent on shaft assembly. Install nut and tighten nut to a torque of 84 to 106 in. lbs. (9.5 to 12 N·m).

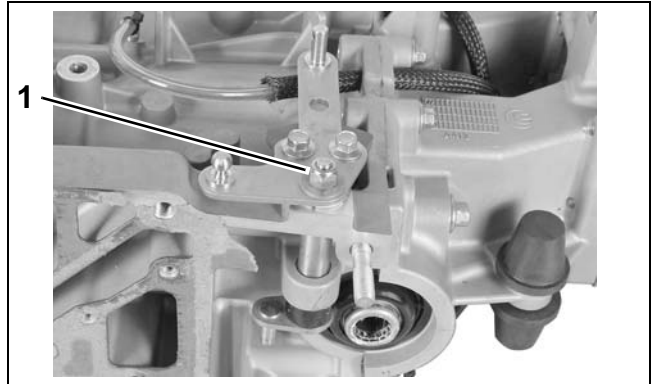

1. Nut 007745

Be sure the shift rod connector is fully seated. Install the shift shaft on the pin and secure with clip.

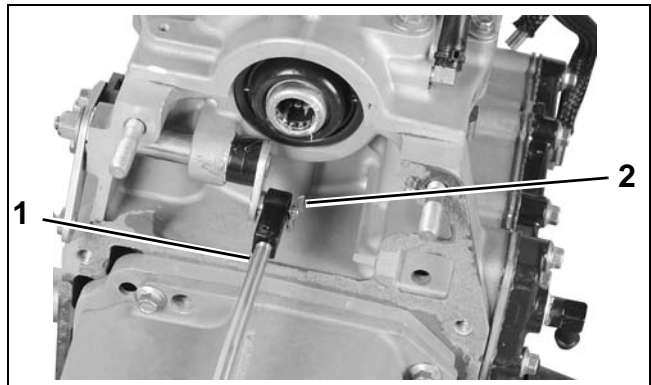

1. Shift shaft  
2. Clip 007742

## Throttle Linkage Installation

Apply *Nut Lock* to threads of throttle lever screw.

Insert spring into cavity of throttle return lever.

Install lever, screw, and washer on crankcase and hook spring on rib as shown. Tighten screw to a torque of 120 to 144 in. lbs. (13.5 to 16 N·m).

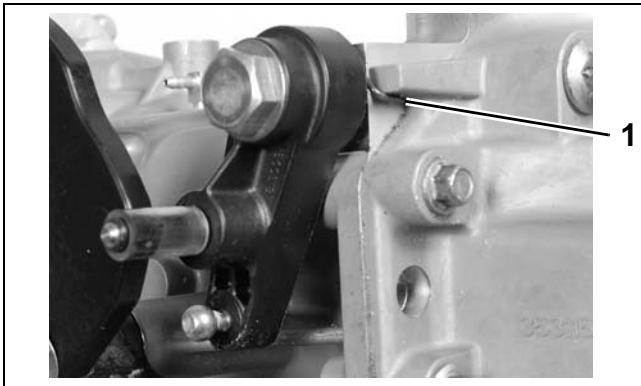

1. Hook spring here

007802

Apply *Nut Lock* to threads of throttle cam screw. Install cam, screw, and washer on cylinder block and tighten screw to a torque of 120 to 144 in. lbs. (13.5 to 16 N·m).

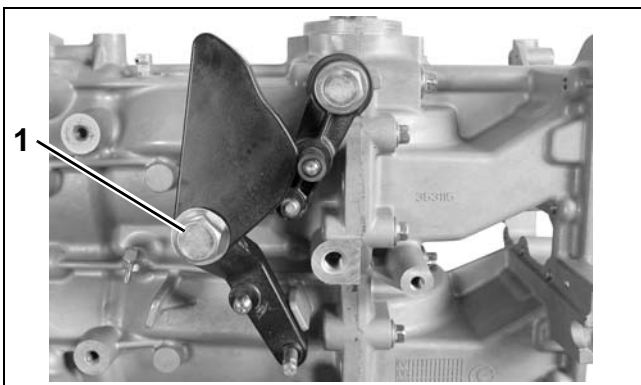

1. Throttle cam screw

007785

**IMPORTANT:** Do not lubricate throttle levers or shoulder screws.

## Final Powerhead Assembly

Install the reed plate and throttle body assemblies. Refer to **Intake Manifold Service** on p. 138.

Install oil recirculating hoses and check valves. Refer to **OIL RECIRCULATION DIAGRAM** on p. 144, or **POWERHEAD VIEWS** on p. 191.

Install thermostat and pressure valve assembly. Refer to **THERMOSTAT AND PRESSURE RELIEF VALVE SERVICING** on p. 164.

Install electrical harness.

Install fuel injectors and ignition coils. Refer to Fuel Injector **Vapor Separator and Fuel Injector Service** on p. 132.

**IMPORTANT:** All injectors must be installed in their original location. Improper injector installation can result in powerhead failure.

Install stator and flywheel. Refer to **FLYWHEEL AND STATOR SERVICING** on p. 103.

Install fuel pump assemblies, fuel manifolds, and filter. Refer to **FUEL COMPONENT SERVICING** on p. 130.

Install the oil tank and oil injection hoses. Refer to **Oil Tank Assembly** on p. 155.

Install the electric starter. Refer to **Starter Installation** on p. 111.

Install *EMM*. Refer to **EMM SERVICING** on p. 66.

Install spark plugs. Refer to Spark Plug **Indexing** on p. 36.

### **WARNING**

To prevent fire and explosion hazard, make sure all electrical and ignition wiring is routed and clamped in original positions.

## POWERHEAD POWERHEAD INSTALLATION

# POWERHEAD INSTALLATION

### Powerhead Mounting

Coat the driveshaft splines with *Moly Lube*. Do not apply lubricant to end of driveshaft splines.

Be sure water tube is placed in upper and lower grommets.



1. Water tube
2. Grommet

007803

Slowly lower powerhead onto exhaust housing. If necessary, rotate flywheel in a clockwise direction to align crankshaft and driveshaft splines.

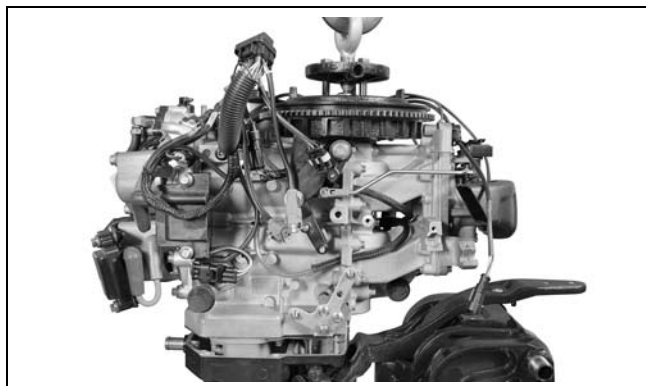

007804

Apply *Triple-Guard* grease to the threads of the powerhead screws.

Loosely install all powerhead screws before tightening:

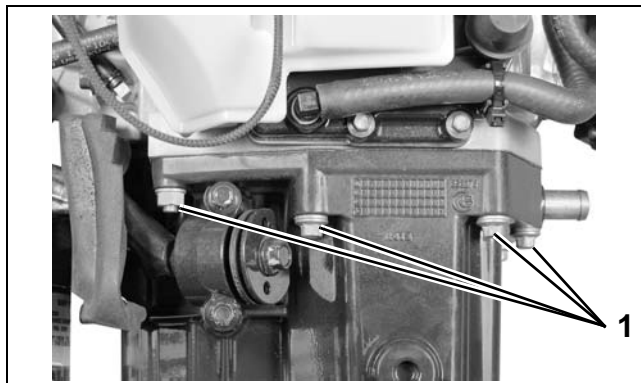

1. Powerhead screws

007741

Tighten the eight powerhead screws to a torque of 18 to 20 ft. lbs. (24 to 27 N·m) in the sequence shown.

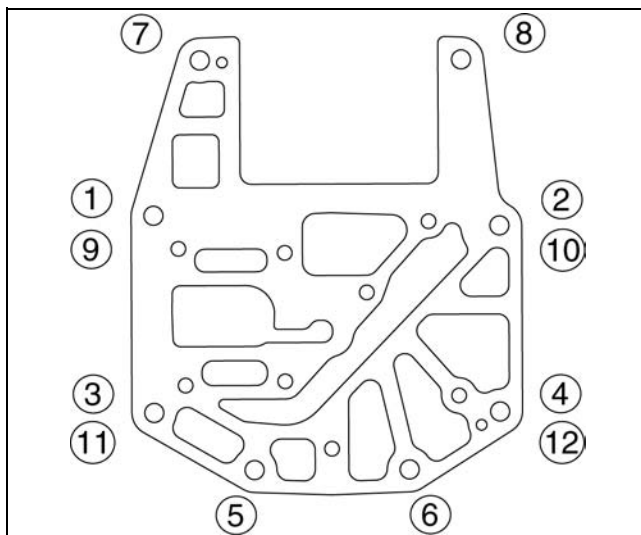

Large screw torque sequence, 1 – 12

007774

**IMPORTANT:** Retighten powerhead mounting screws after outboard has been run at full operating temperature and allowed to cool.

Place the upper shift rod in the shift rod connector. Install the retaining screw and lock washer. Tighten screw to a torque of 60 to 84 in. lbs. (7 to 9.5 N·m).

Install water screens.

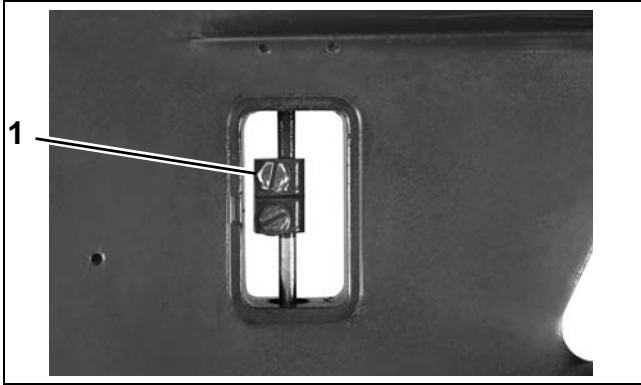

1. Shift rod screw

7650

Check shift linkage adjustment. Refer to **Shift Linkage Adjustment** on p. 189.

**IMPORTANT:** Make sure the gearcase shifts solidly into both forward and reverse and that propeller shaft spins freely in neutral.

Connect the power trim connectors. Secure cables in clamps.

Install recoil starter ratchet and housing on outboard. Refer to **RECOIL STARTER INSTALLATION** on p. 282.

Install the lower engine covers. Refer to **Lower Cover Installation** on p. 45.

## Shift Linkage Adjustment

Adjust shift linkage as follows:

**STEP 1:** Move shift lever into neutral position.

- Make sure shift lever detent is in neutral position.
- Make sure gearcase is in neutral.
- Loosen two shift lever screws.

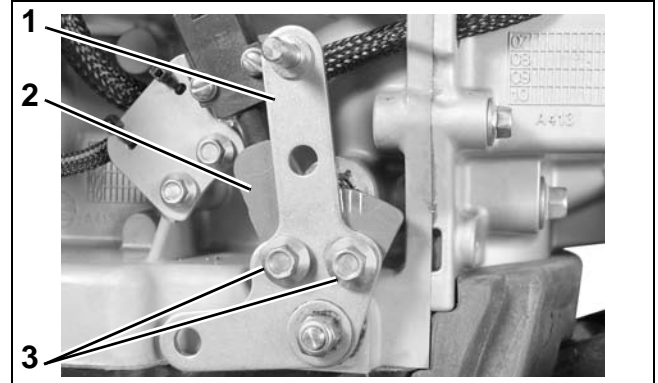

1. Shift lever
2. Shift lever detent
3. Shift lever screws

008461

**STEP 2:** Find shift lever midpoint.

- Move the shift lever forward to the limit of free play. Mark this as forward line on the neutral detent.
- Move the shift lever rearward to the limit of free play. Mark this as rearward line on the neutral detent.
- Measure the midpoint between the forward and rearward lines. Make a third line on the on the neutral detent. Mark this as midpoint line.
- Align the shift lever to the midpoint line.

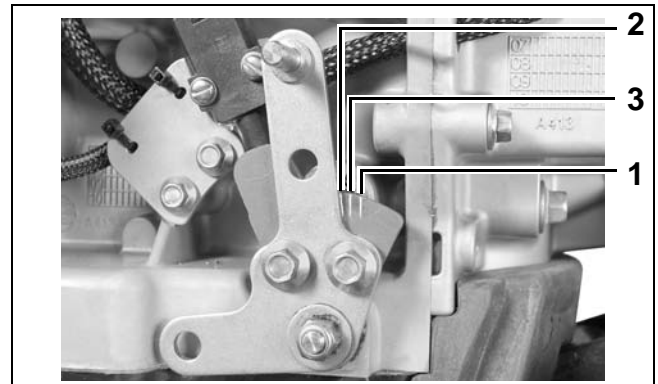

1. Forward line
2. Rearward line
3. Midpoint line

008461

## POWERHEAD

### POWERHEAD INSTALLATION

**STEP 3:** Secure shift lever to shift lever detent.

- Remove one shift lever screw. Clean screw and apply *Nut Lock* to threads.
- Reinstall the shift lever screw.
- Hold shift lever on midpoint line and tighten screw to a torque of 80 to 106 in. lbs. (9 to 12 N·m).
- Remove remaining shift lever screw. Clean screw and apply *Nut Lock* to threads. Reinstall and tighten screw to a torque of 80 to 106 in. lbs. (9 to 12 N·m).

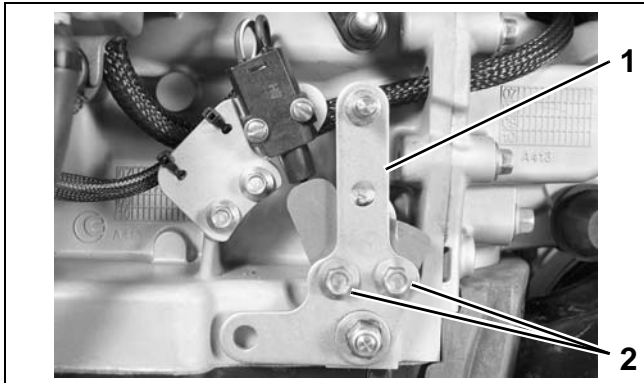

1. Shift lever
2. Shift lever screws

008463

Adjust neutral switch. Refer to **Neutral Switch Adjustment** on p. 25.

## Final Adjustments

**NOTICE** After installing a new or rebuilt powerhead, perform the following procedures before returning outboard to service:

- Index all spark plugs. Refer to **Spark Plug Indexing** on p. 36.
- Use *Evinrude Diagnostics* software to start powerhead break-in oiling. Refer to **Powerhead Break-In** on p. 62.
- Use *Evinrude Diagnostics* software to make sure engine management software version and revision are current. Update as required.
- Use *Evinrude Diagnostics* software to confirm neutral switch operation. Refer to **Neutral Switch Adjustment** on p. 25.
- Prime fuel system.
- Prime oiling system. Refer to **Oil Supply Priming** on p. 150.
- Use *Evinrude Diagnostics* software to check engine timing. Refer to **TIMING ADJUSTMENTS** on p. 106.
- Run outboard and check for water, fuel, or oil leaks.
- Make sure engine reaches correct operating temperature and does not overheat.



**Port Electric Start Models**



008359

**Starboard Electric Start Models**

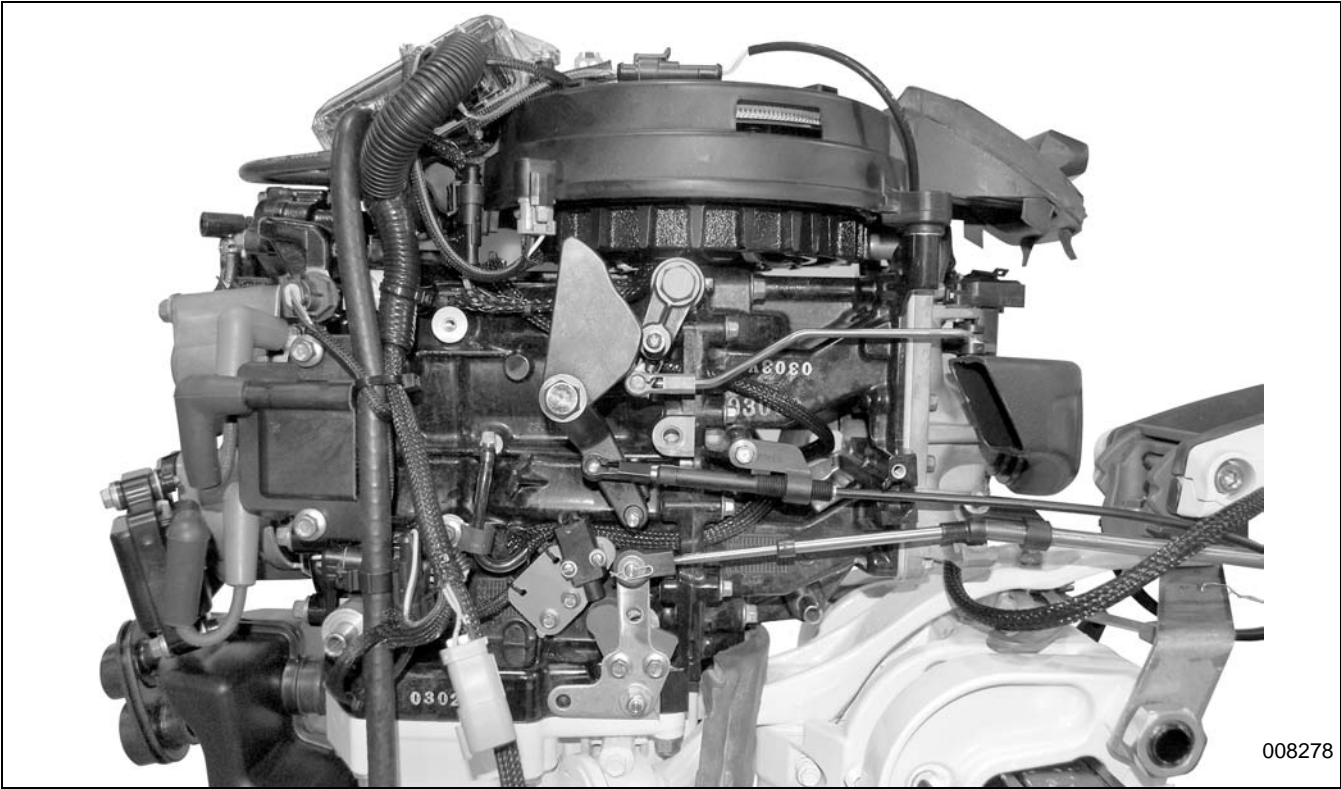

008278

**POWERHEAD**  
**POWERHEAD VIEWS**

**Port Rope Start Models**

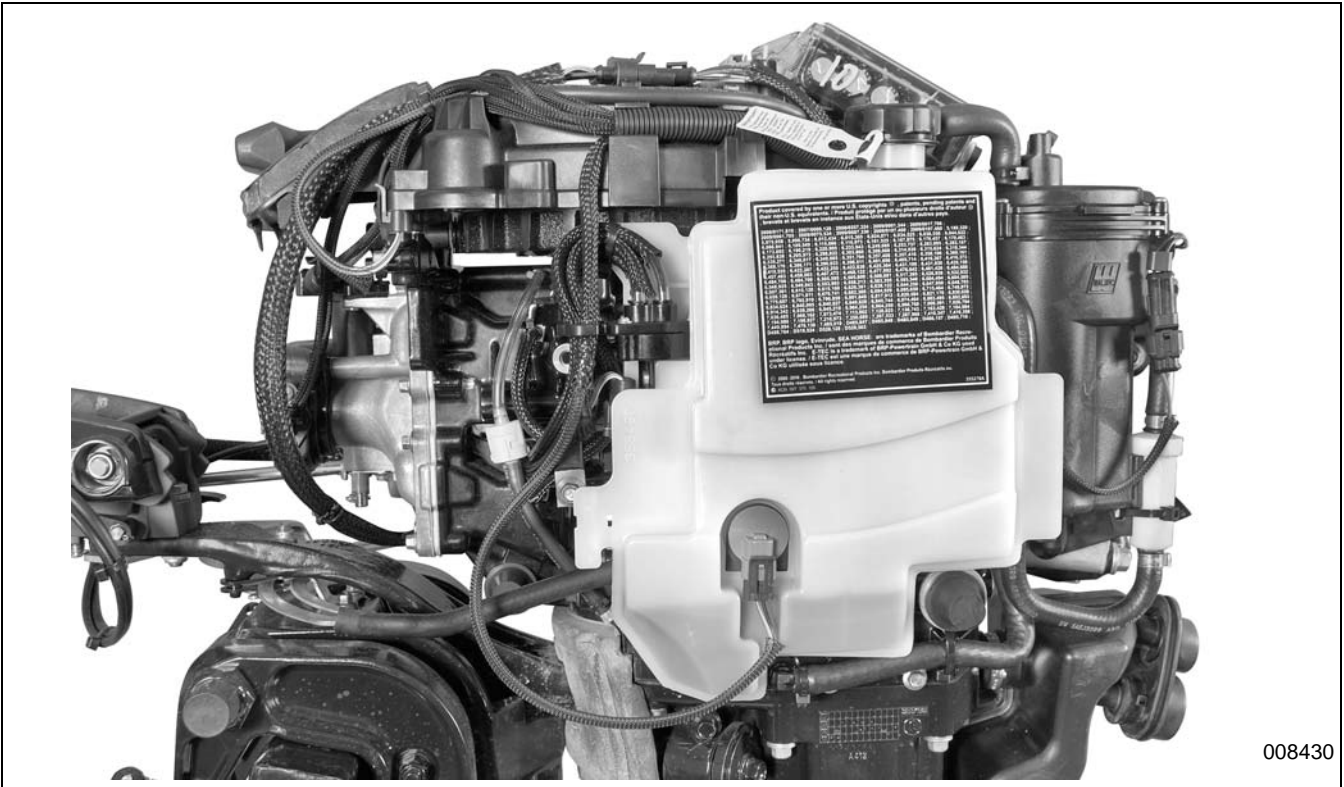

008430

**Starboard Rope Start Models**

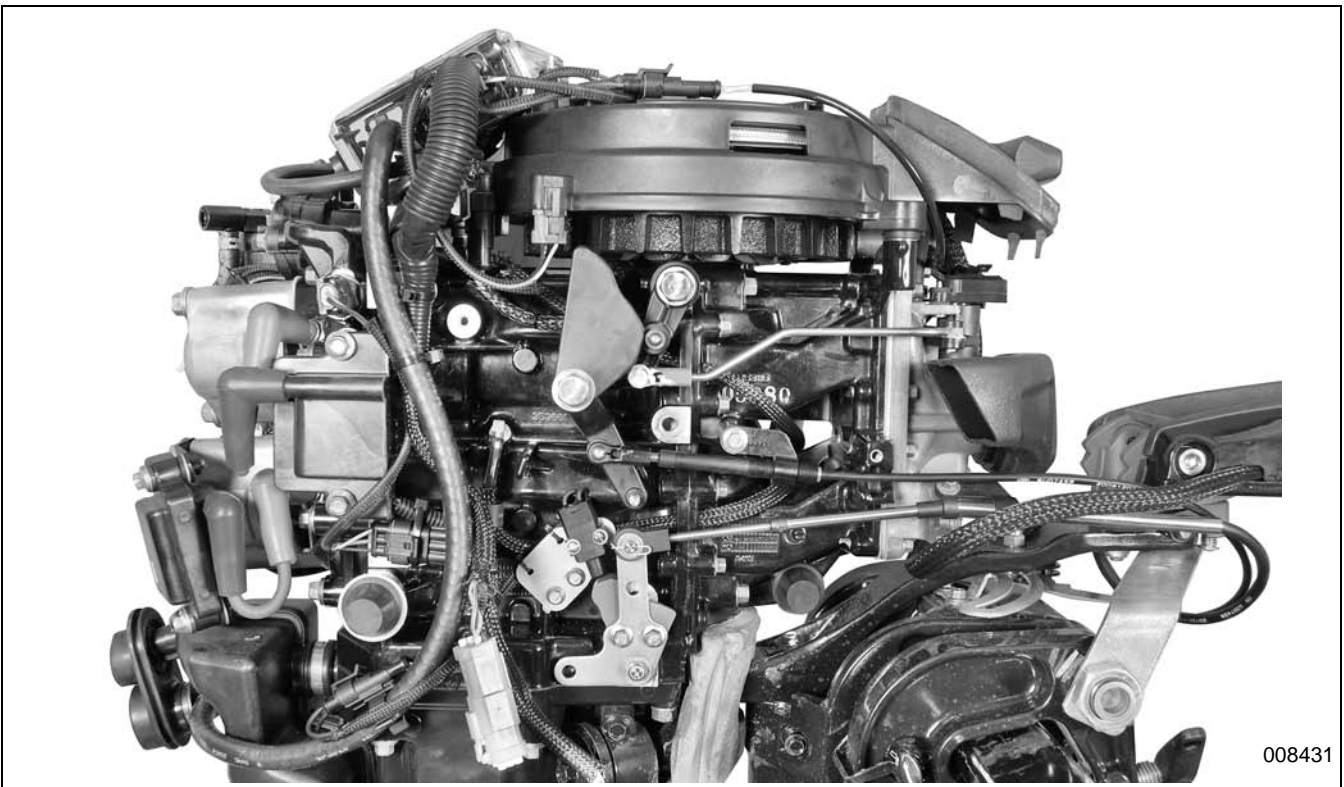

008431

**Front**

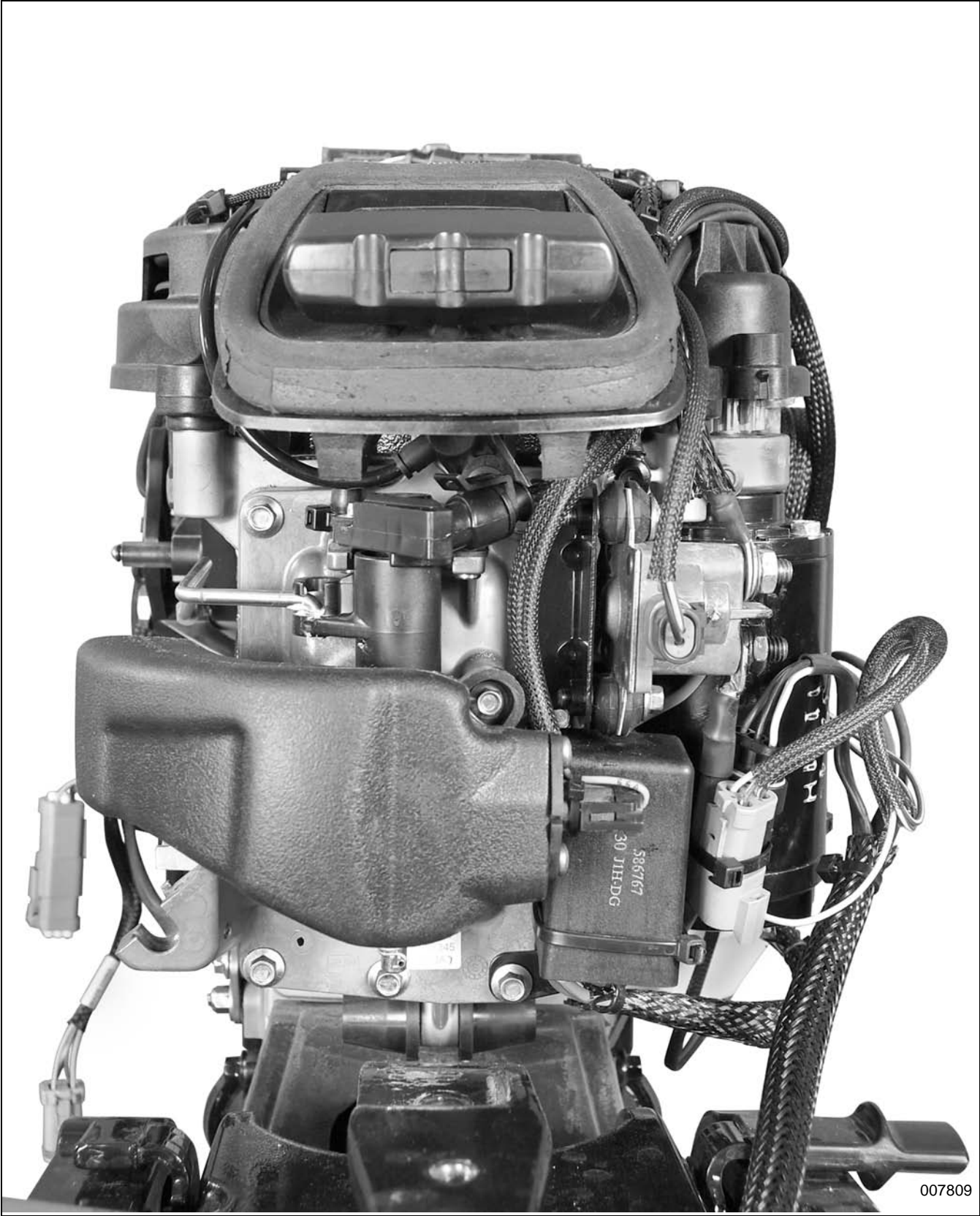

**10**

007809

**POWERHEAD**  
**POWERHEAD VIEWS**

**Rear**

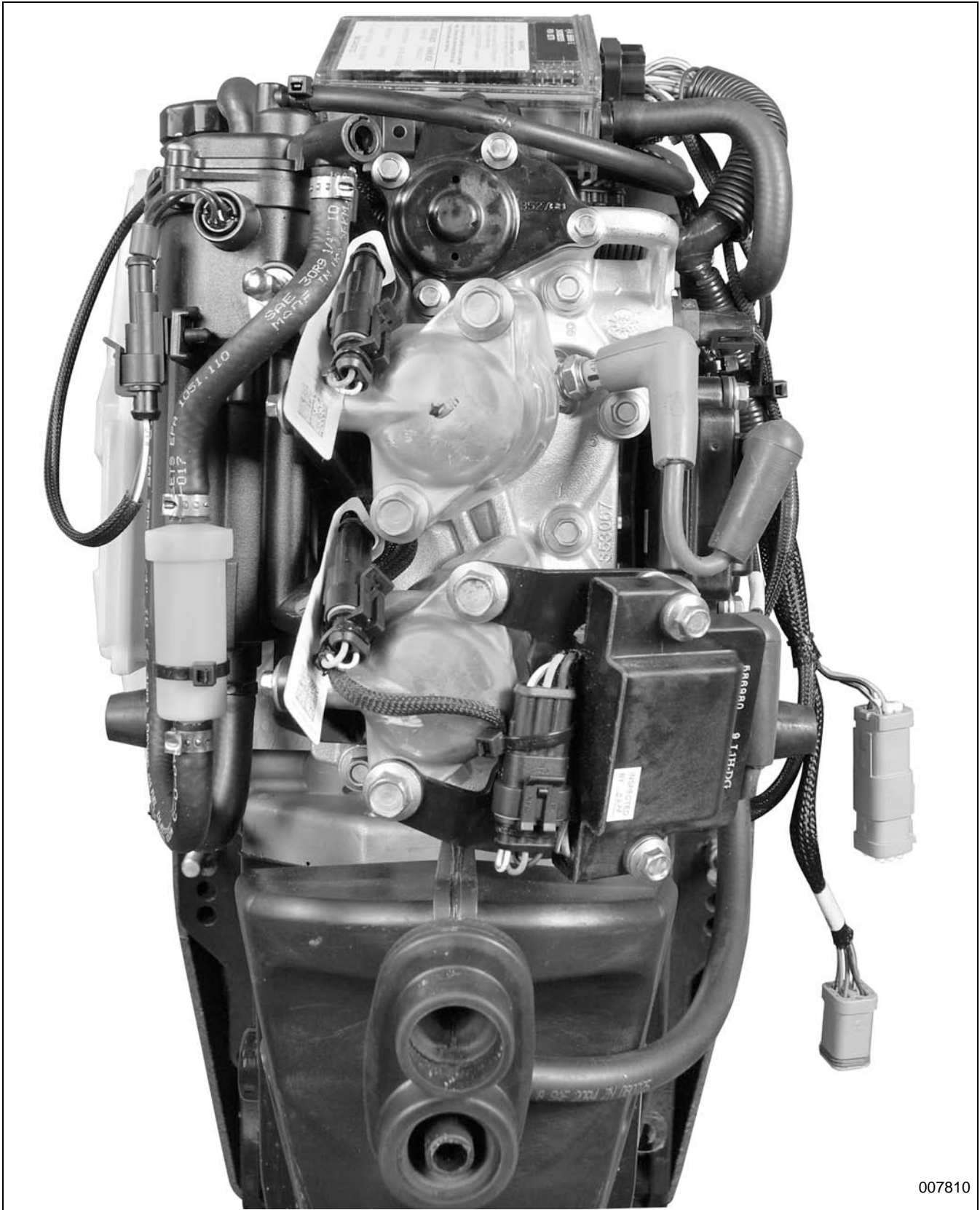

007810

**Top**

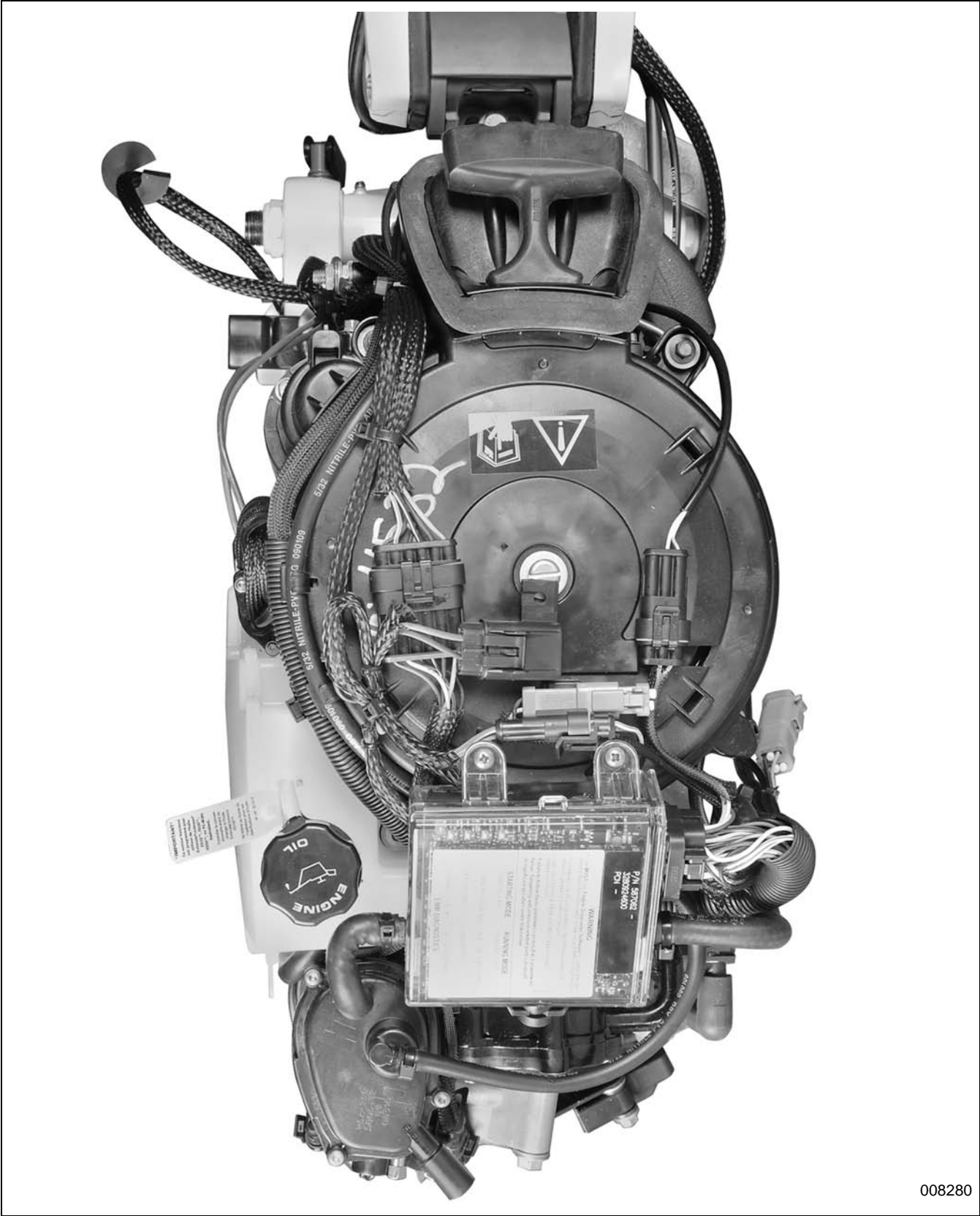

**10**

008280



---

# MIDSECTION

## TABLE OF CONTENTS

SERVICE CHART .....	198
EXHAUST HOUSING SERVICE .....	203
EXHAUST HOUSING REMOVAL .....	203
EXHAUST HOUSING INSTALLATION .....	203
MOUNT SERVICE .....	204
EXHAUST RELIEF MUFFLER .....	206
EXTENSION SERVICE – 25” MODELS .....	207
REMOVAL .....	207
INSTALLATION .....	207
STERN BRACKET – POWER TILT MODELS .....	208
STERN BRACKET DISASSEMBLY (POWER TILT) .....	208
STERN BRACKET ASSEMBLY (POWER TILT) .....	210
TRIM SENDING UNIT REMOVAL .....	214
TRIM SENDING UNIT INSTALLATION .....	215
STERN BRACKET – MANUAL TILT MODELS .....	216
CLAMP SCREW SERVICE .....	216
STERN BRACKET DISASSEMBLY (MANUAL TILT) .....	216
STERN BRACKET ASSEMBLY (MANUAL TILT) .....	221
TILLER HANDLE SERVICE .....	227
REMOVAL .....	227
DISASSEMBLY .....	228
INSPECTION .....	232
ASSEMBLY .....	232
INSTALLATION .....	239
CONTROL CABLE INSTALLATION .....	240



# SERVICE CHART

**STERN BRACKET, 15 HP POWER TILT MODELS**

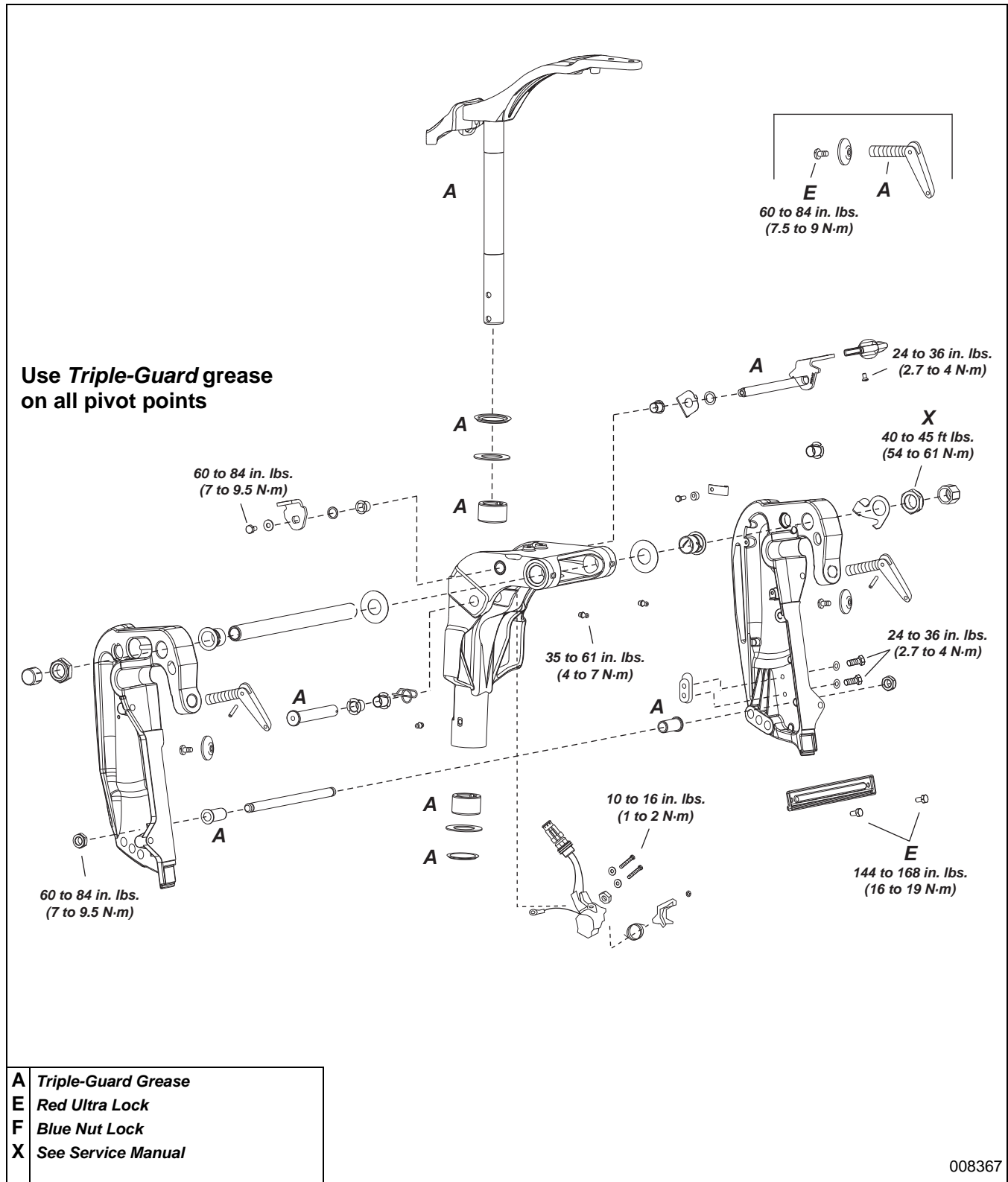



**STERN BRACKET, 25 – 30 HP POWER TILT MODELS**

**Use Triple-Guard grease  
on all pivot points**

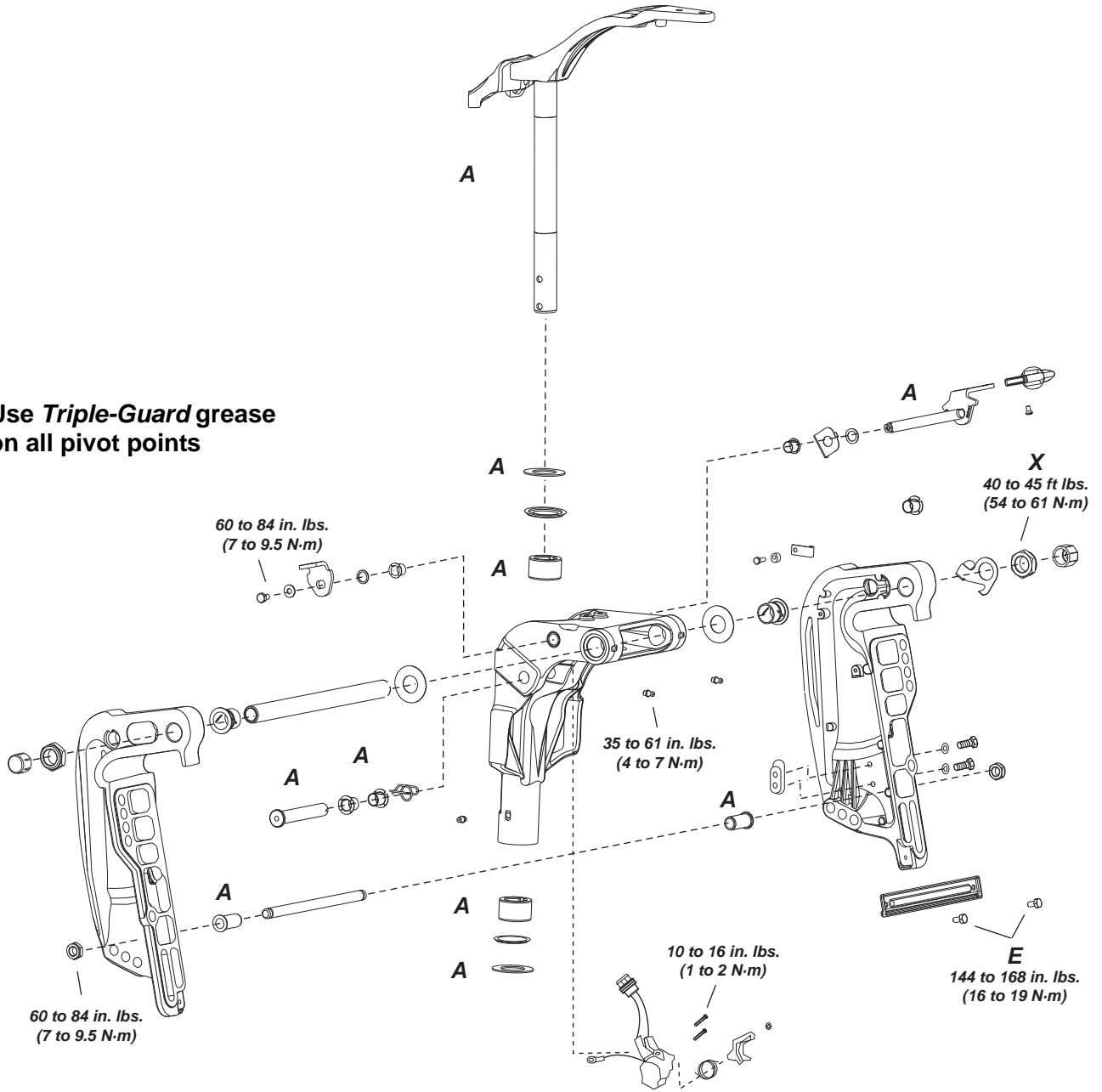

007625

- A** Triple-Guard Grease
- E** Red Ultra Lock
- F** Blue Nut Lock
- X** See Service Manual





# MIDSECTION SERVICE CHART

## TILLER HANDLE

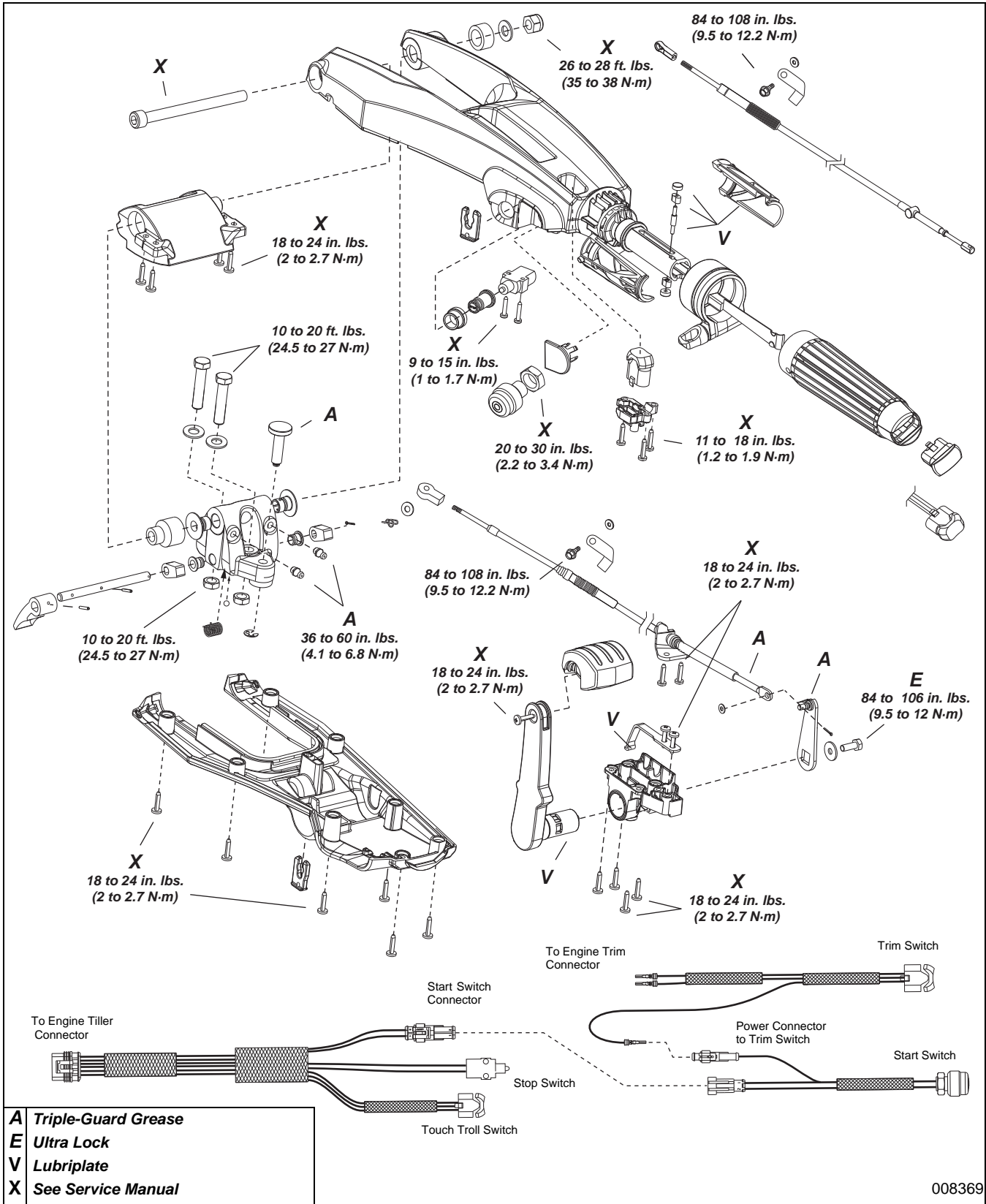

# EXHAUST HOUSING SERVICE

The exhaust housing contains no serviceable internal parts. The exhaust relief muffler and motor mounts can be serviced without removing the exhaust housing.

## Exhaust Housing Removal

Before removing the exhaust housing:

- Remove the gearcase. Refer to **GEARCASE REMOVAL AND INSTALLATION** on p. 248.
- Remove the powerhead. Refer to **POWERHEAD REMOVAL** on p. 170.

Remove two upper mount and two lower mount screws.

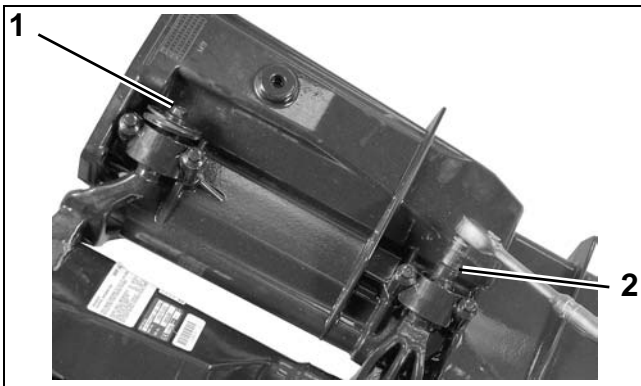

1. Upper mount screw  
2. Lower mount screw  
007566

Remove bumpers and bumper stops from upper mounts. Remove washers from lower mounts.

Remove the exhaust housing.

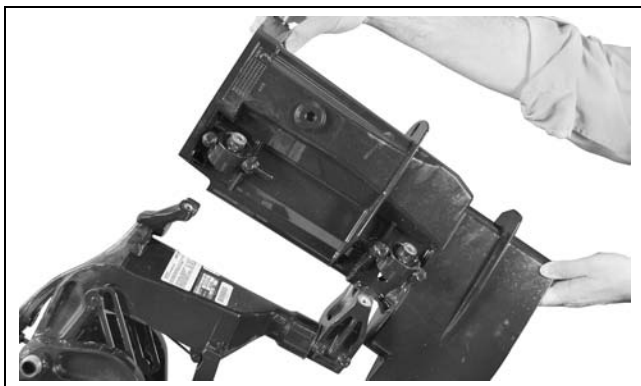

Exhaust Housing  
007567

Remove lower mount bracket rubber mount.

Check condition of the lower front mount. Replace if deteriorated or damaged.

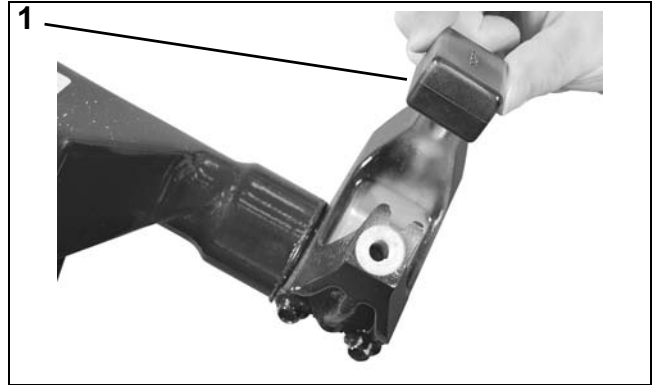

1. Rubber mount  
007568

## Exhaust Housing Installation

Install lower mount bracket rubber mount.

Bring the exhaust housing into position with the stern bracket.

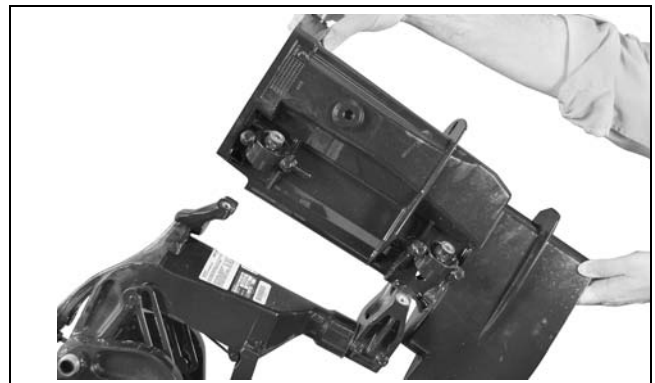

Exhaust Housing  
007567

Install bumpers, bumper stops and screws on upper mounts. Install washers and screws on lower mounts. Refer to **Mount Service** on p. 204.

Install gearcase. Refer to **GEARCASE REMOVAL AND INSTALLATION** on p. 248.

Install powerhead. Refer to **POWERHEAD INSTALLATION** on p. 188.

## MIDSECTION EXHAUST HOUSING SERVICE

### Mount Service

Individual upper and lower motor mounts can be serviced without removing the exhaust housing.

Remove the lower motor covers. Refer to **Lower Cover Removal** on p. 45.

### Removal

Remove mount screw and washer(s).

Remove two mount to exhaust housing screws.

Remove mount.

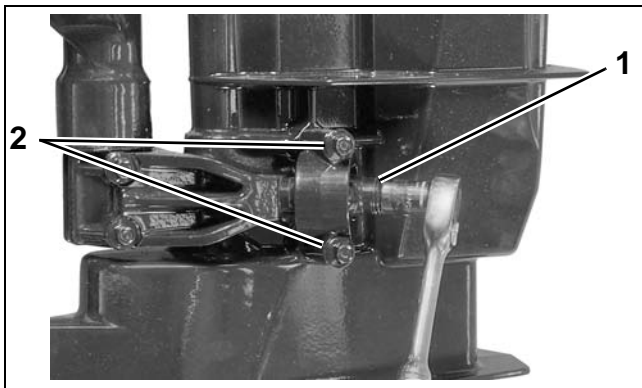

1. Mount screw
2. Mount to exhaust housing screws

007569

Check condition of the mounts. Replace if deteriorated or damaged.

### Installation

Apply *Triple-Guard* grease to threads of the two mount to exhaust housing screws.

Install mount to exhaust housing with two mount to exhaust housing screws. Install screws finger tight at this time.

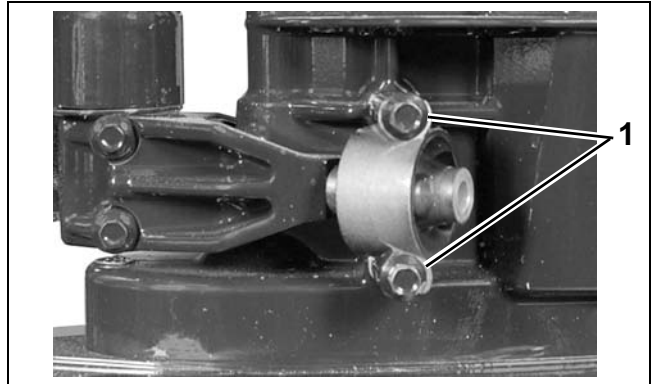

1. Mount to exhaust housing screws

007570

**Upper mount:** Install rubber bumper.

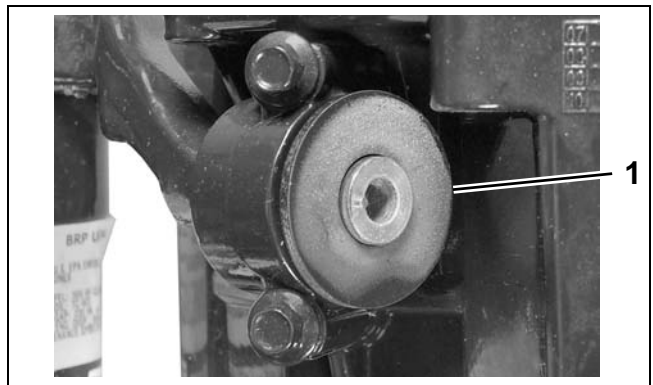

1. Rubber bumper

007571

Install washer. Align slot with pin as shown.

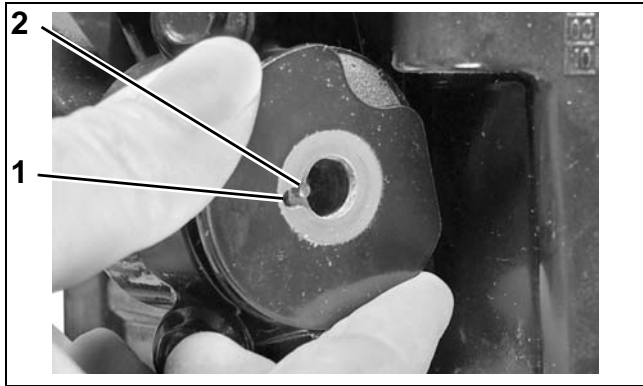

1. Slot
2. Pin

007572

Apply *Triple-Guard* grease to threads of the upper mount screw. Install screw through upper mount.

Tighten screw to a torque of 22 to 23 ft. lbs. (30 to 32 N·m).

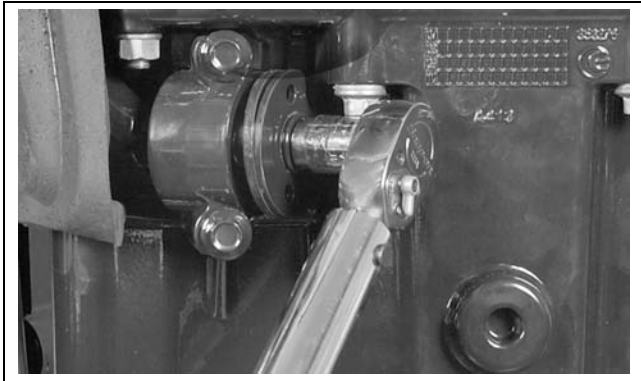

007573

**IMPORTANT:** Make sure upper mount bumper stop slot stays aligned with pin as screw is tightened.

**Lower mount:** Apply *Triple-Guard* grease to threads of the lower mount screws.

Install rubber bumper and washer.

Install screw through lower mount.

Tighten screw to a torque of 22 to 23 ft. lbs. (30 to 32 N·m).

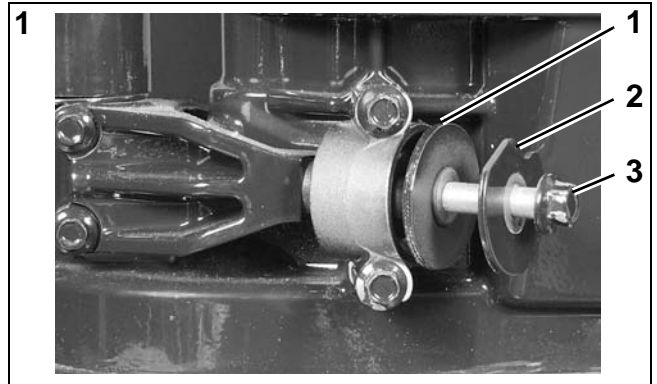

1. Rubber bumper
2. Washer
3. Screw

008427

Tighten two mount to exhaust housing screws to a torque of 10 to 12 ft. lbs. (14.5 to 16.5 N·m).

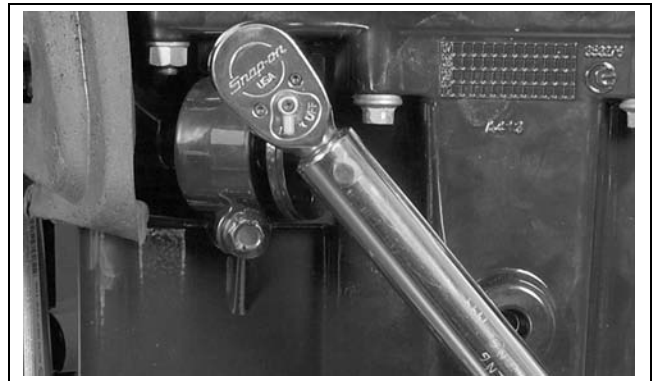

007575

Install lower motor covers. Refer to **Lower Cover Installation** on p. 45.

**MIDSECTION**  
**EXHAUST HOUSING SERVICE**

**Exhaust Relief Muffler**

The exhaust relief muffler has no serviceable parts, replace as needed.

Remove lower motor covers. Refer to **Lower Cover Removal** on p. 45

Remove overboard indicator grommet from muffler. Remove *Oetiker* clamp.

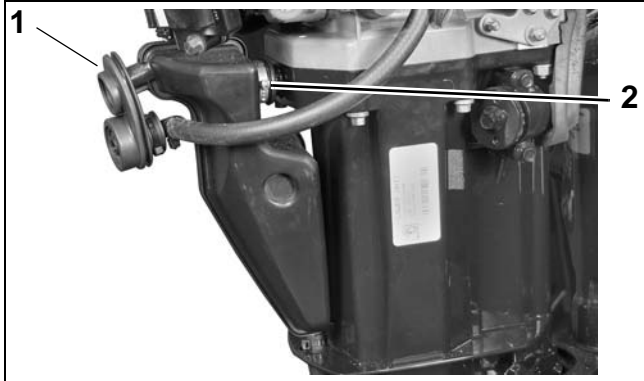

1. Overboard indicator grommet  
2. Oetiker clamp

007576

Install muffler drain hose on new muffler with tie strap.



007577

Install muffler drain hose through hole.



007578

Secure muffler with new *Oetiker* clamp.

Install overboard indicator grommet on muffler.

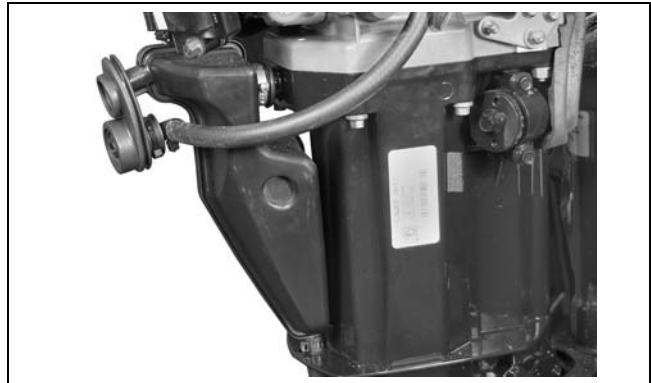

007576

Install lower motor covers. Refer to **Lower Cover Installation** on p. 45



## EXTENSION SERVICE – 25" Models

### Removal

Remove gearcase. Refer to **Gearcase Removal** on p. 248.

Remove extension.



1. Extension

008372

Remove studs from exhaust housing only if studs are loose.

### Installation

If studs are removed, clean threads with cleaning solvent.

Apply *Ultra Lock* to upper threads of studs. Install studs and tighten to a torque of 10 to 12 ft. lbs. (14.5 to 16.5 N·m).

Install extension.

Apply *Triple-Guard* grease to lower threads of studs.

Install gearcase. Refer to **Gearcase Installation** on p. 248.

# STERN BRACKET – Power Tilt Models

## Stern Bracket Disassembly (Power Tilt)

If outboard is equipped with a tiller arm, remove the tiller arm. Refer to **TILLER HANDLE SERVICE** on p. 227.

Remove exhaust housing. Refer to **EXHAUST HOUSING SERVICE** on p. 203.

Remove lower mount bracket retaining screws.

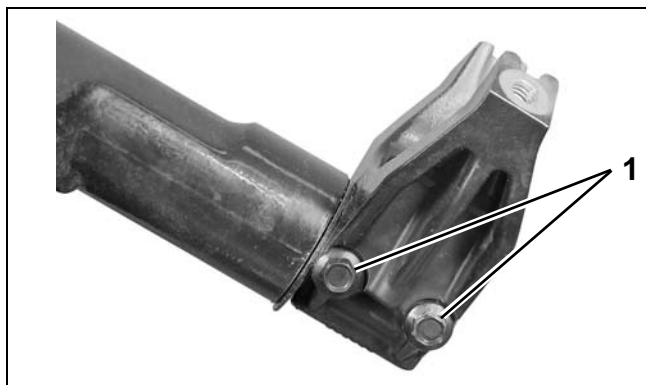

1. Screws 007682

Use a soft mallet to remove lower mount bracket and thrust washer.

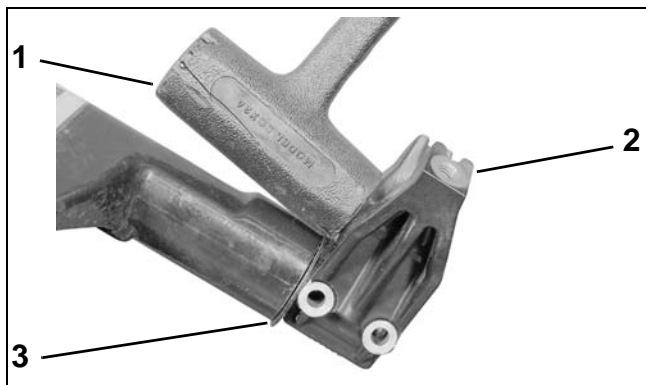

1. Mallet  
 2. Lower mount bracket  
 3. Thrust washer 007683

If equipped with a steering friction device, remove the steering friction nut.

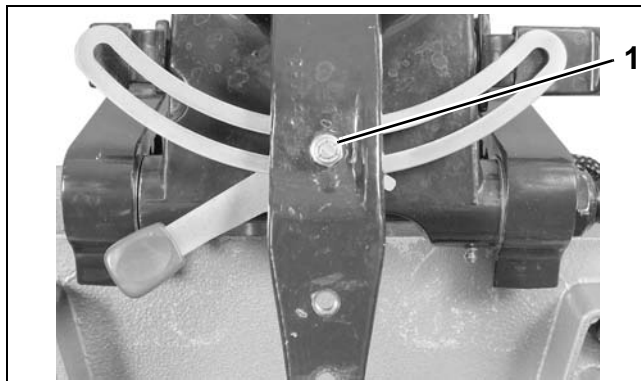

1. Steering friction nut 007684

Slide the steering arm out of the swivel bracket and remove the thrust washer .

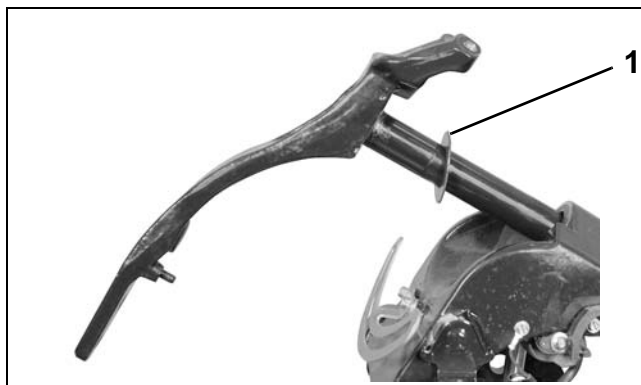

1. Upper thrust washer 007685

Remove the steering friction lever, washers and plate.

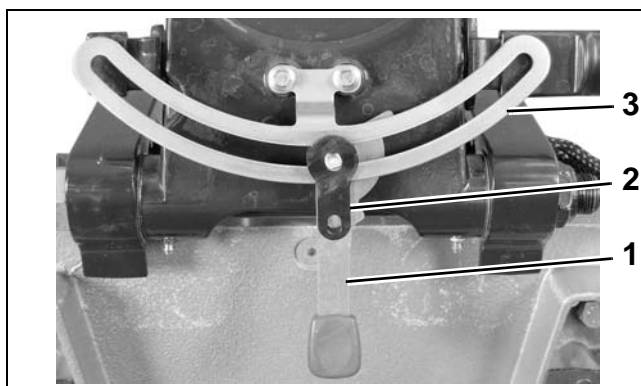

1. Steering friction lever  
 2. Steering friction washers  
 3. Steering friction plate 007686

## MIDSECTION STERN BRACKET – POWER TILT MODELS

Use an appropriate tool to pry the upper and lower seals from the swivel bracket.



007687



007688

Remove the upper and lower bushings from the swivel bracket.

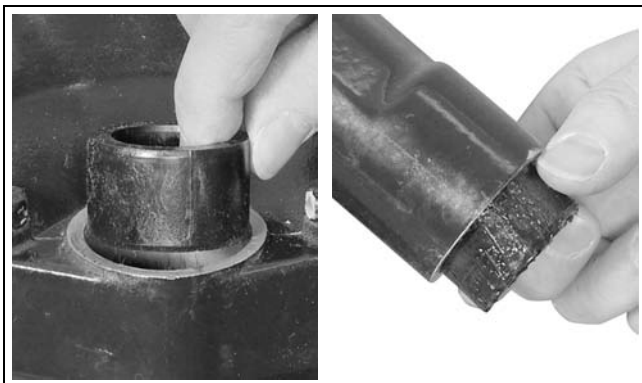

007689  
007690

Raise the outboard and engage the tilt support.

Remove the electrical connector from the trim sending unit. Refer to **CONNECTOR SERVICING** on p. 111.

Remove the trim/tilt cable connector. Refer to **TRIM AND TILT REPLACEMENT** on p. 273.

Remove the clip from the cylinder pin.

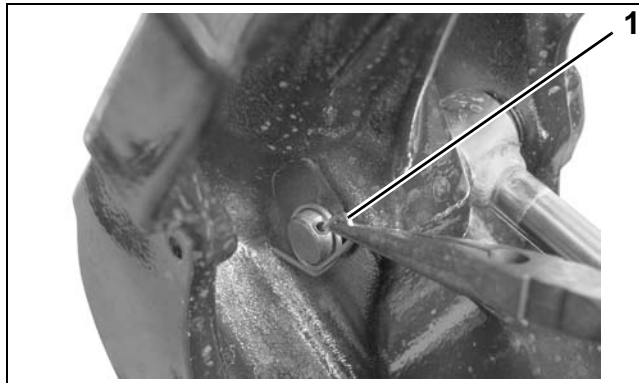

1. Clip

007637

Remove one of the locknuts from the angle adjustment rod.

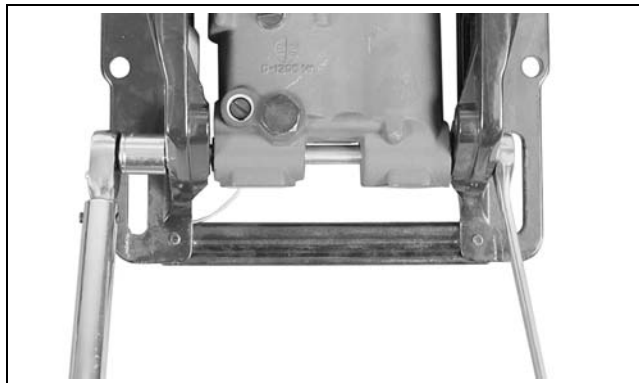

007691

Remove the tie bar

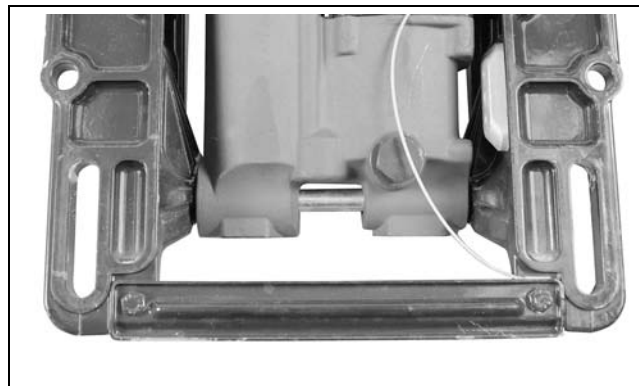

007692

## MIDSECTION

### STERN BRACKET – POWER TILT MODELS

Remove angle adjustment rod and remove the hydraulic unit.



007693

Check the condition of the anode. Replace the anode if it has been reduced to two-thirds its original size.



007695

To separate stern and swivel brackets, remove tilt tube nuts, tilt tube, bushings, thrust washers, and cable clamp.

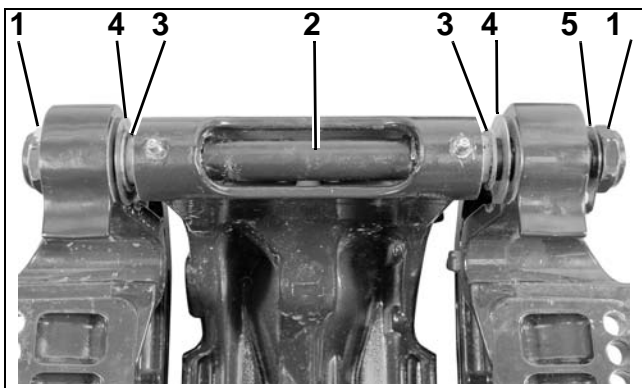

007694

1. Tilt tube nuts
2. Tilt tube
3. Bushings
4. Thrust washers
5. Cable clamp

### Stern Bracket Assembly (Power Tilt)

Assemble stern and swivel brackets with tilt tube nuts, tilt tube, bushings, thrust washers, and cable clamp.

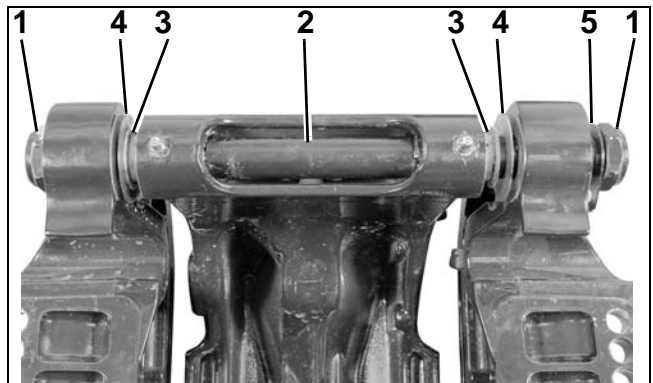

007694

1. Tilt tube nuts
2. Tilt tube
3. Bushings
4. Thrust washers
5. Cable clamp

**MIDSECTION**  
**STERN BRACKET – POWER TILT MODELS**

Make sure cable clamp is positioned as shown.

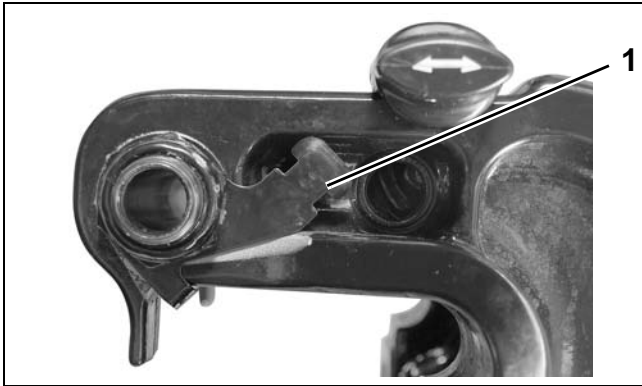

1. Cable clamp

007696

Route the hydraulic unit and trim sender harnesses through the grommet in the port stern bracket.

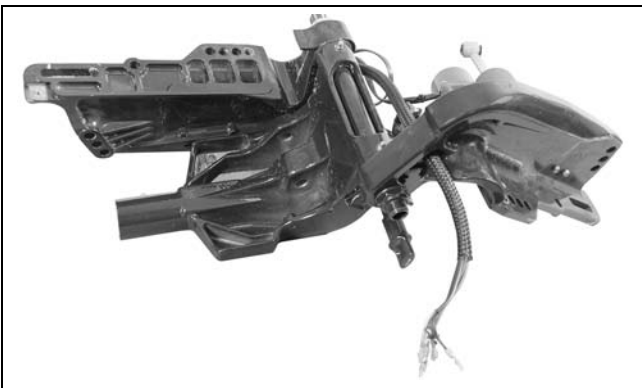

007697

Secure harness in wire clamp as shown.

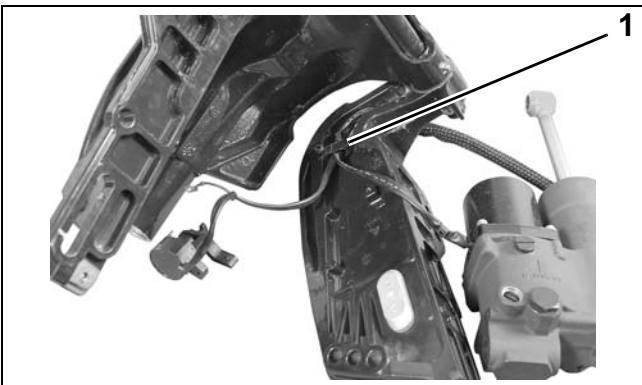

1. Wire clamp

007698

Install bushings in hydraulic unit. Position hydraulic unit between stern brackets and install the angle adjustment rod.

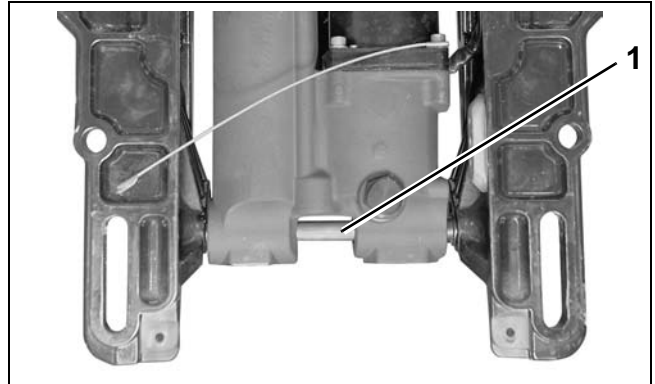

007699

Place the ground lead between the port stern bracket and tie bar as shown. Assemble the tie bar to the stern brackets. Apply *Ultra Lock* to the threads of the tie bar screws. Install the screws and tighten to a torque of 144 to 168 in. lbs. (16 to 19 N·m).

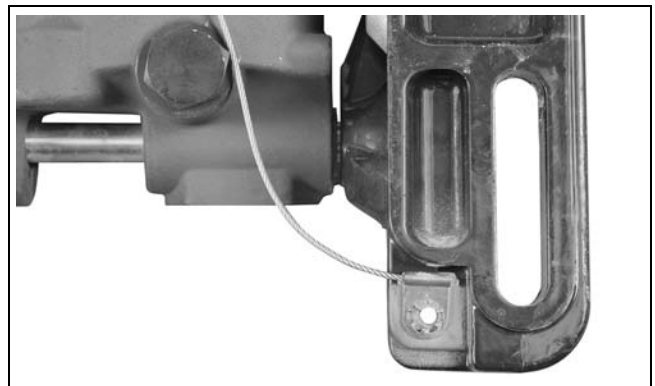

007700

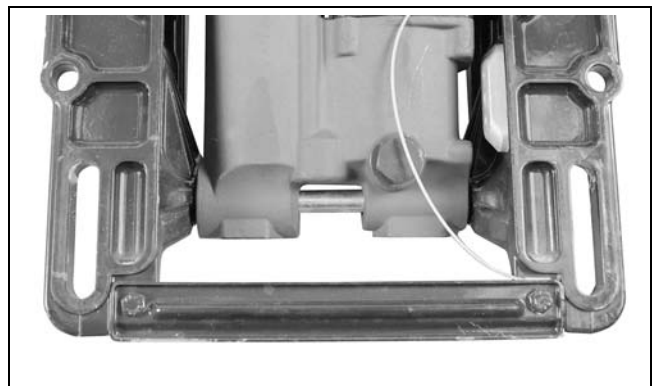

007692

**MIDSECTION**  
**STERN BRACKET – POWER TILT MODELS**

Install the cylinder pin and secure with clip.

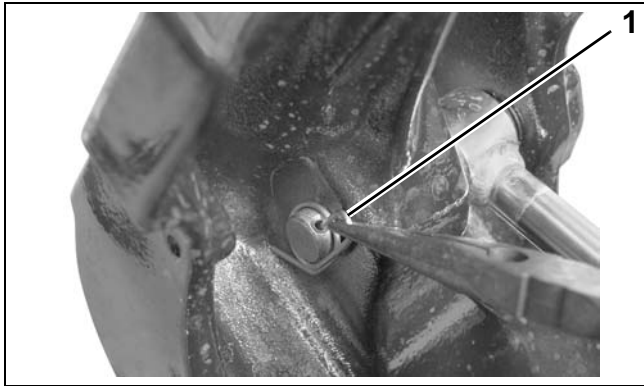

1. Clip 007637

Tighten the locknuts to a torque of 60 to 84 in. lbs. (7 to 9.5 N·m).

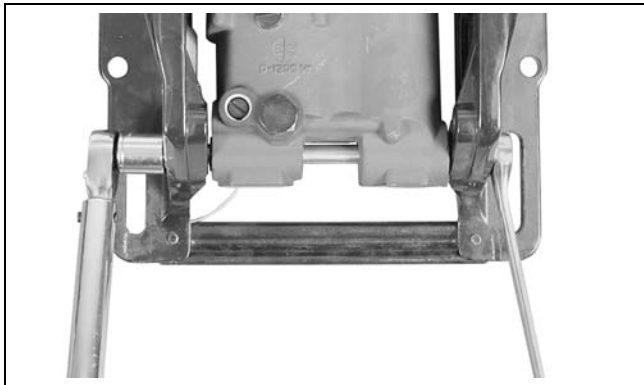

007691

Install the trim sending unit. Refer to **Trim Sending Unit Installation** on p. 215.

Apply a light coat of *Triple-Guard* grease to the outside of the upper and lower bushings.

Install the upper and lower bushings in the swivel bracket.

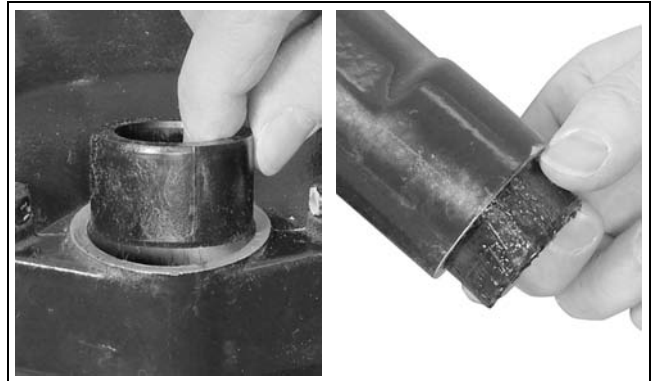

007689  
 007690

Use Seal Installation tool, P/N 350958, to install new upper and lower seals in the swivel bracket. Install seals with lips of seals facing in.

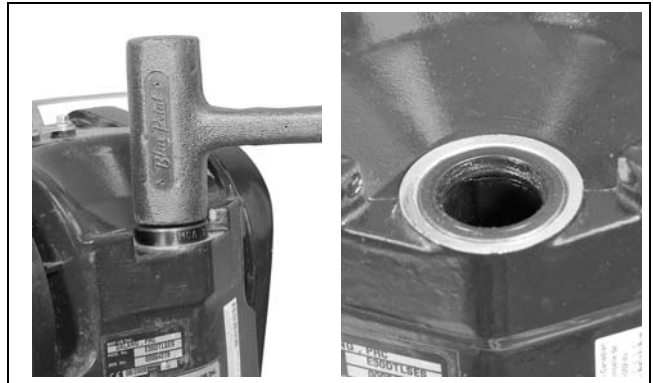

007701  
 007702

Install the steering friction plate, washers and lever.

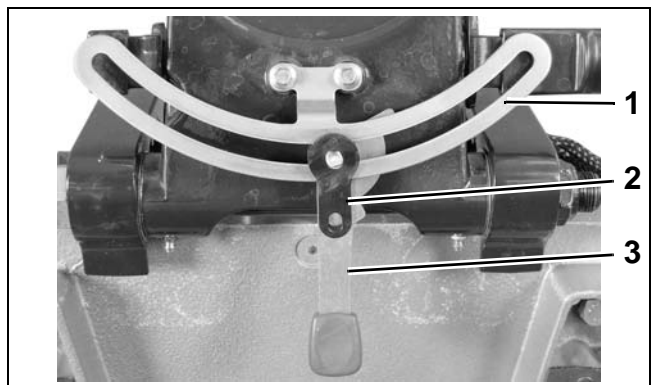

1. Steering friction plate  
 2. Steering friction washers  
 3. Steering friction lever 007686

Apply *Triple-Guard* grease to both sides of thrust washer. Install thrust washer on steering arm.

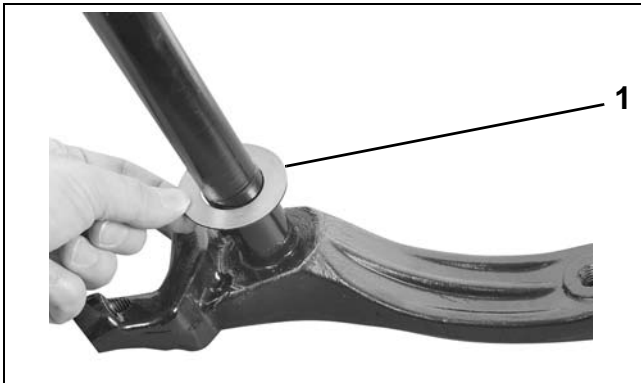

1. Thrust washer 007617

Align dowel pin and steering friction lever as shown.

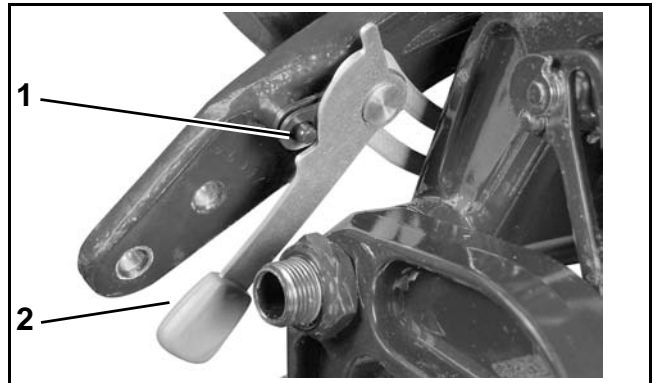

5. Dowel pin 007458  
6. Steering friction lever

Slide the steering arm with thrust washer through the swivel bracket.

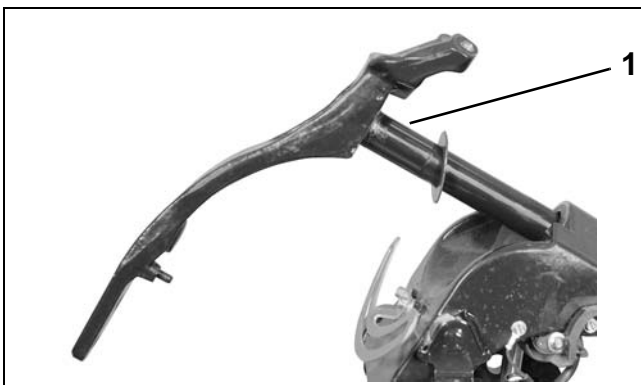

1. Upper thrust washer 007685

Install locking nut. Temporarily tighten locking nut three to four full turns. Final adjustment will be performed later.

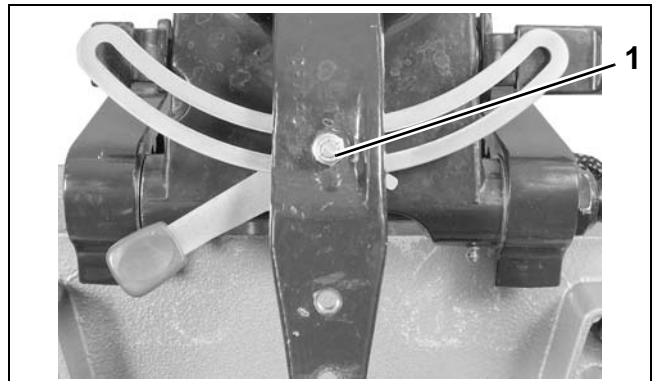

1. Steering friction nut 007684

Align slots of friction washers with dowel pin.

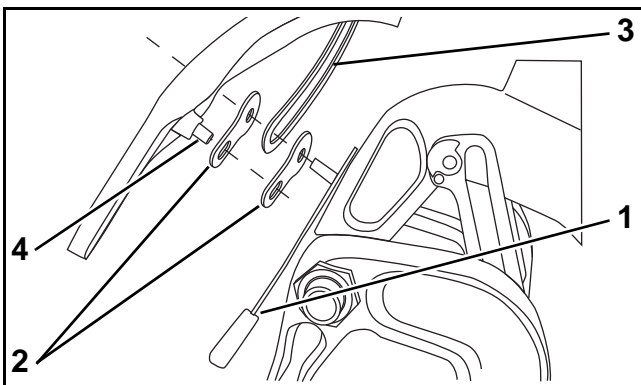

1. Steering friction lever 007491  
2. Friction washers  
3. Friction plate  
4. Dowel pin

Apply *Triple-Guard* grease to both sides of thrust washer. Install thrust washer on steering arm.

Install lower mount bracket on steering arm.

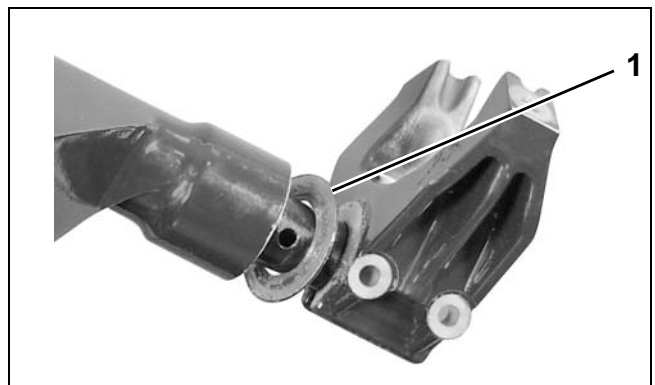

1. Thrust washer 007624

## MIDSECTION

### STERN BRACKET – POWER TILT MODELS

Install lower mount retaining screws. Tighten screws to a torque of 10 to 12 ft. lbs. (14.5 to 16.5 N-m).

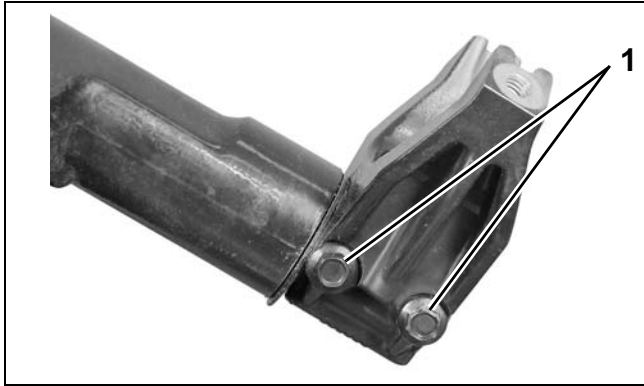

1. Retaining screws

007682

Tighten the tilt tube nuts to a torque of 40 to 45 ft. lbs. (54 to 61 N-m), then back off 1/8 to 1/4 turn.

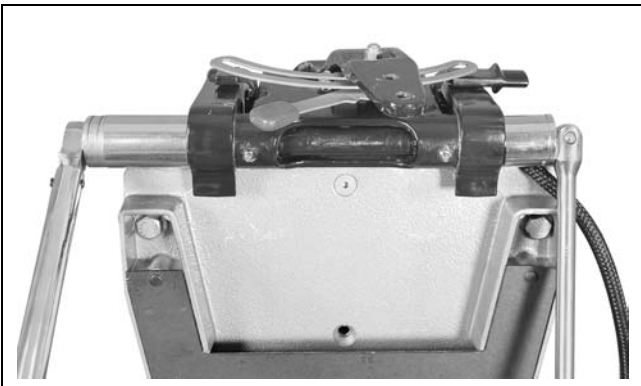

007703

Install exhaust housing. Refer to **EXHAUST HOUSING SERVICE** on p. 203.

Install tiller handle. Refer to **TILLER HANDLE SERVICE** on p. 227.

Adjust tiller steering friction. Refer to **Steering Friction Adjustment** on p. 24.

## Trim Sending Unit Removal

Remove two screws. Remove sending unit and washers from swivel bracket.

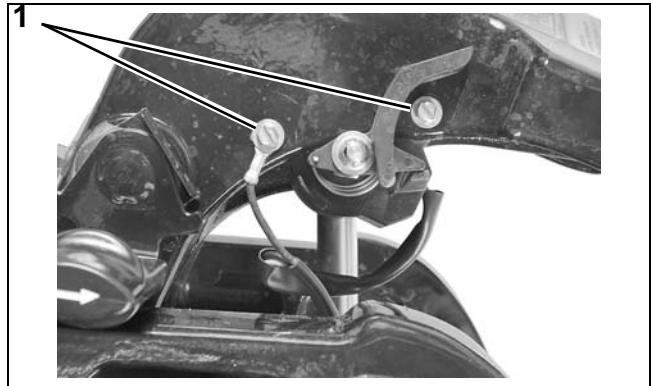

1. Screws

007704

Remove trim sender electrical connector from harness. Refer to **CONNECTOR SERVICING** on p. 111.

Remove tie straps from harness. Pull harness from stern bracket to remove sending unit.

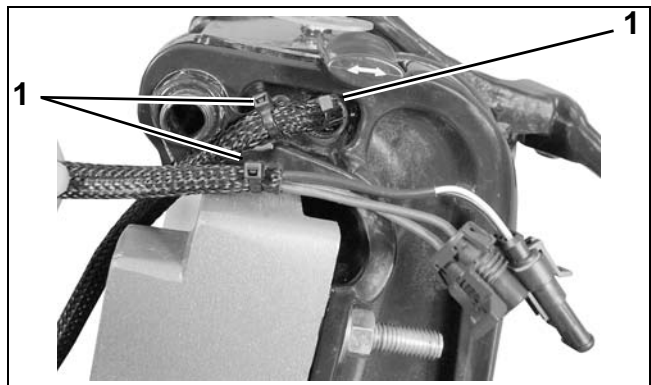

1. Tie straps

007705



## Trim Sending Unit Installation

Route trim sending unit harness through port stern bracket grommet. Secure harness in wire clamp as shown.

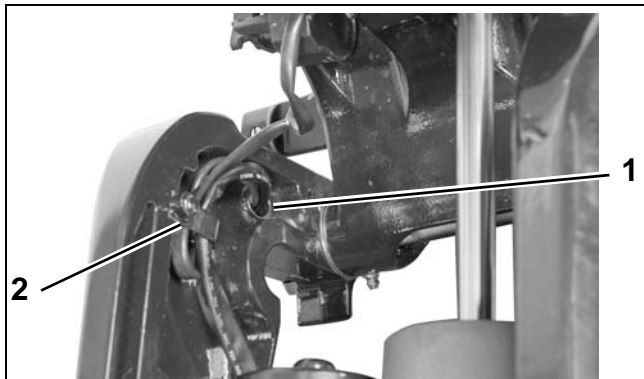

1. Grommet  
2. Wire clamp  
007706

Place rear screw through hole. Place two washers on rear screw. Position sending unit and install rear screw.

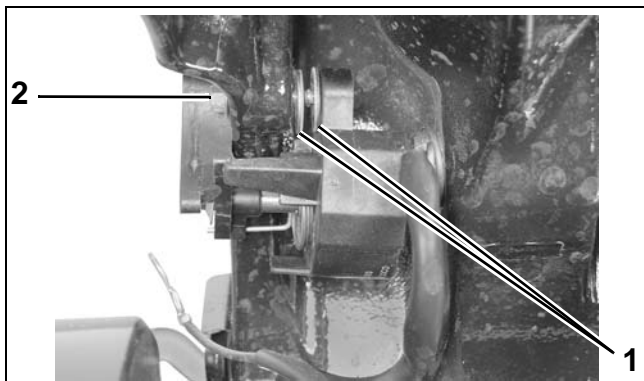

1. Washers  
2. Rear screw  
007707

Place ground wire over front screw and install front screw. Tighten screws to a torque of 10 to 16 in. lbs. (1 to 2 N·m).

### ⚠ CAUTION

When reinstalling screws in composite materials turn screws **COUNTER-CLOCKWISE** until threads of screw engage threads of screw boss.

Failure to follow this procedure will damage the screw boss threads. Once threads are engaged, tighten screws securely.

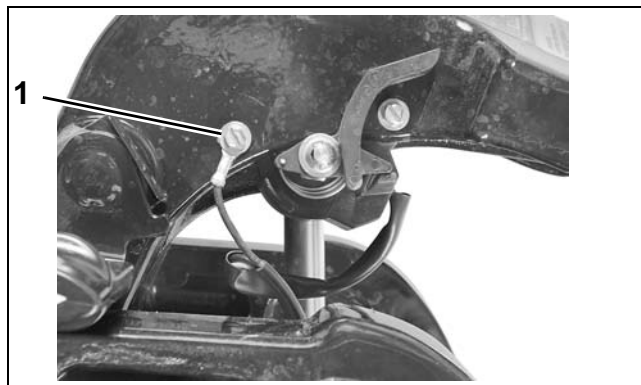

1. Front screw  
007704

Install trim sender electrical connector on harness. Refer to **CONNECTOR SERVICING** on p. 111.

Install tie straps on cable clamp and harness.

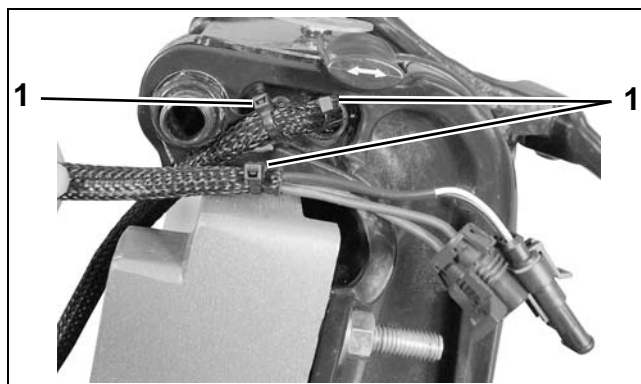

1. Cable clamp  
2. Tie straps  
007705

**IMPORTANT:** Operate trim unit and make sure the wiring harness will not be damaged between stern and swivel brackets.

## MIDSECTION

### STERN BRACKET – MANUAL TILT MODELS

# STERN BRACKET – Manual Tilt Models

## Clamp Screw Service

Inspect clamp screw assemblies. Replace swivel plate and shoulder screw if bent or loose.

Disassemble swivel plate and shoulder screw.

Inspect and clean clamp screw and shoulder bolt threads.

Install clamp screw and handle assembly in transom bracket.



1. Clamp screw and handle assembly

007579

Install swivel plate, onto shoulder screw.

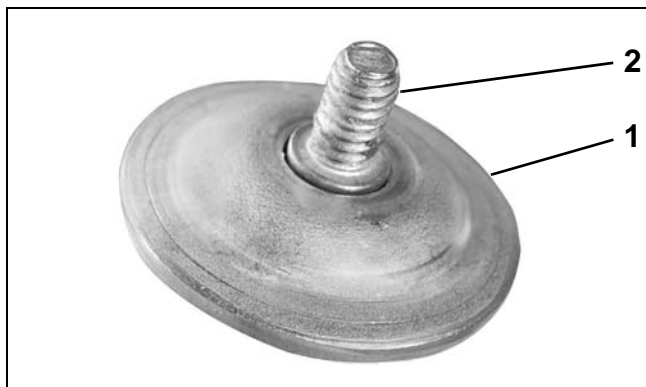

1. Swivel plate  
2. Shoulder screw

007580

Apply *Locquic Primer* to the threads of the screw and allow it to dry four to five minutes. Then apply *Ultra Lock* to threads.

Install shoulder screw and swivel plate onto clamp screw and handle assembly.

Tighten screw to a torque of 60 to 84 in. lbs. (7.5 to 9 N-m).

Check for free movement of swivel plate on shoulder bolt.

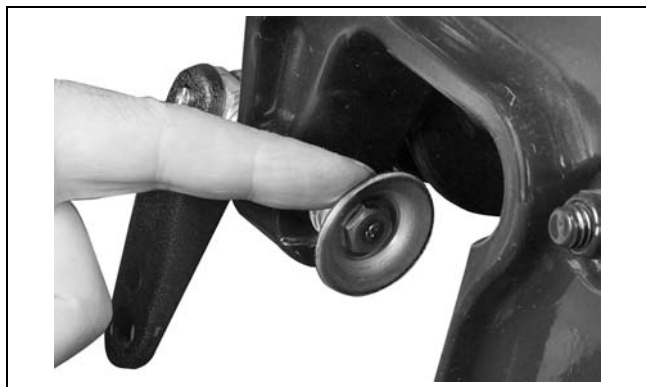

007581

## Stern Bracket Disassembly (Manual Tilt)

If outboard is equipped with a tiller arm, remove the tiller arm. Refer to **TILLER HANDLE SERVICE** on p. 227.

Remove exhaust housing. Refer to **EXHAUST HOUSING SERVICE** on p. 203.

Remove lower mount bracket retaining screws.

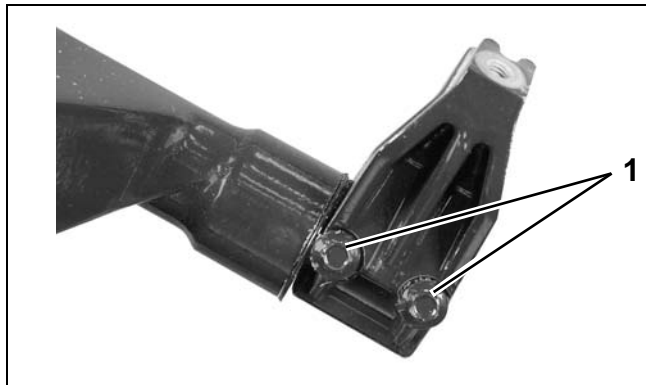

1. Screws

007582

**MIDSECTION**  
**STERN BRACKET – MANUAL TILT MODELS**

Use a soft mallet to remove lower mount bracket and thrust washer.

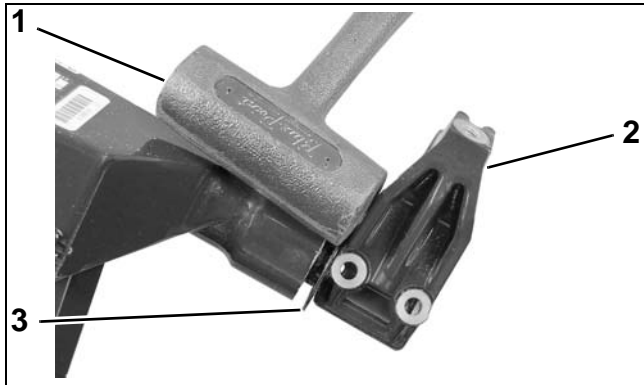

- 1. Mallet
  - 2. Lower mount bracket
  - 3. Thrust washer
- 007583

Remove the steering friction lever, washers and plate.

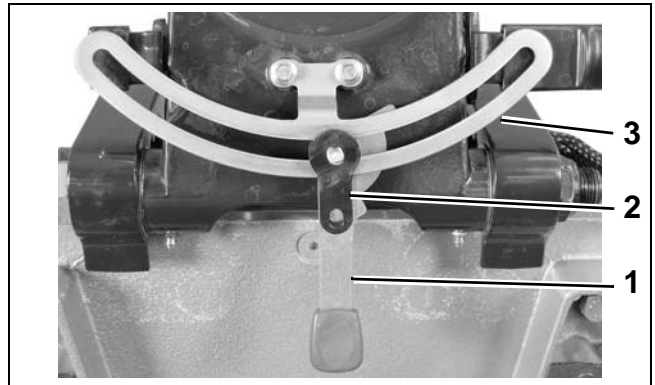

- 1. Steering friction lever
  - 2. Steering friction washers
  - 3. Steering friction plate
- 007686

If equipped with a steering friction device, remove the steering friction nut.

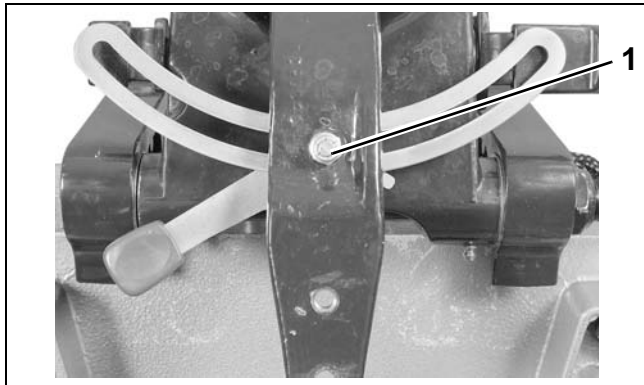

- 1. Steering friction nut
- 007684

Use an appropriate tool to pry the upper and lower seals from the swivel bracket.

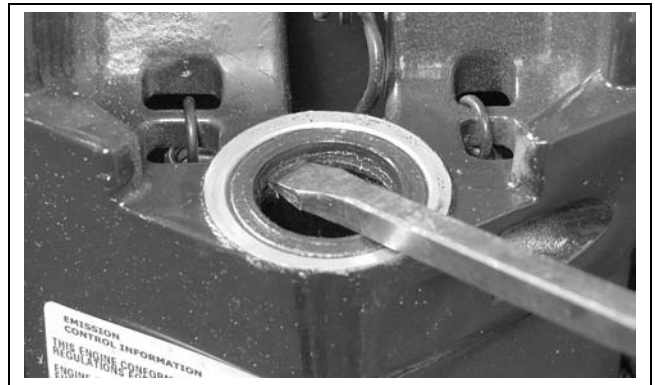

007585

Slide the steering arm out of the swivel bracket and remove the thrust washer .

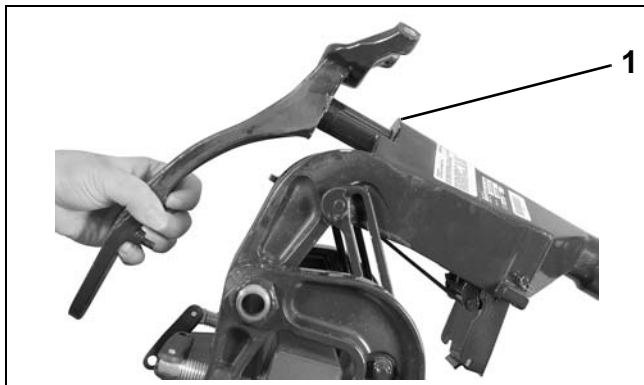

- 1. Upper thrust washer
- 007584

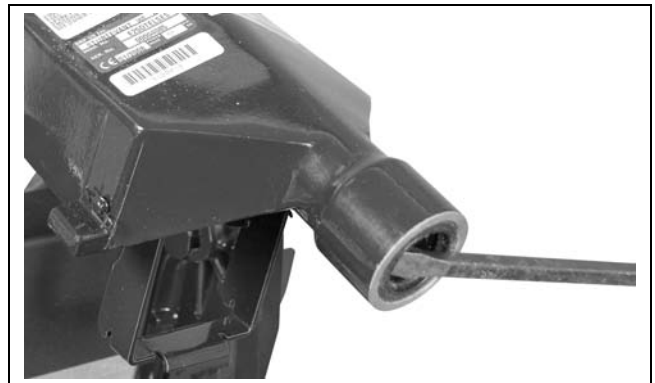

007586

**MIDSECTION**  
**STERN BRACKET – MANUAL TILT MODELS**

Remove the friction screw and spring. Remove upper and lower bushings from the swivel bracket.

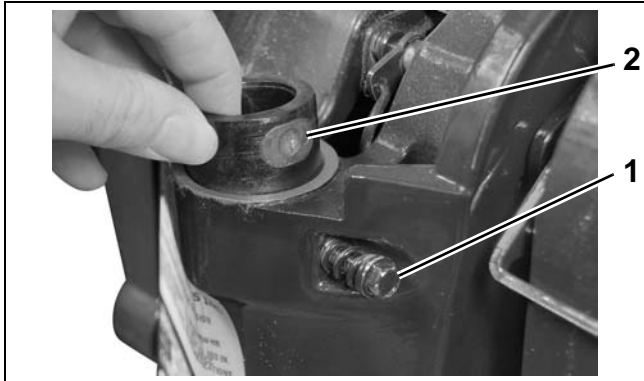

1. Friction plate  
 2. Friction screw  
 007618



007588

Loosen tilt tube nuts four to five turns.

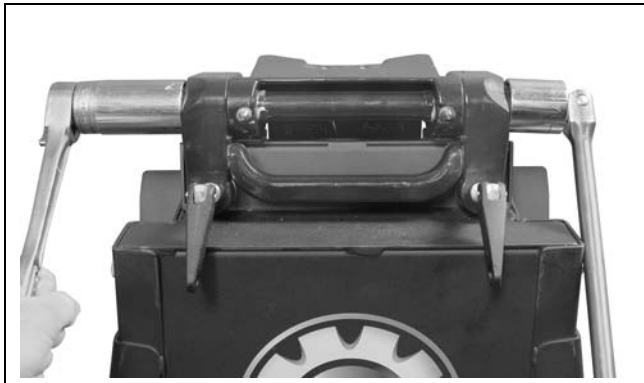

007589

Remove the tilt pin, two tie bar screws and tie bar.

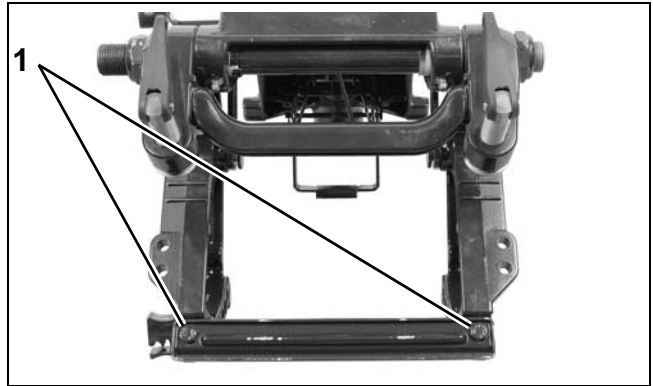

1. Tie bar screws  
 007590

Remove nuts, washers and pins from stern brackets.

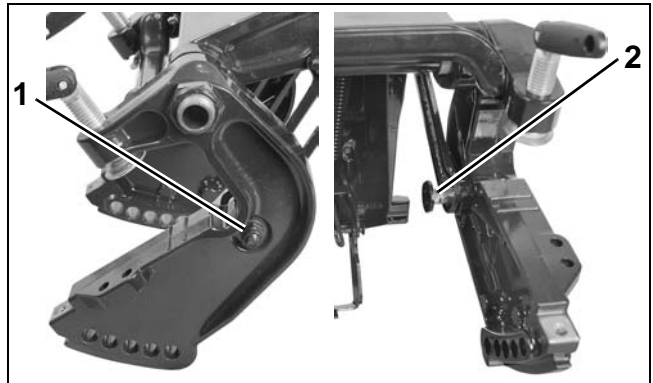

1. Nut and washer  
 2. Pin  
 007591  
 007592

Remove tilt tube nuts, tilt tube, bushings, thrust washers, handle and stern brackets.

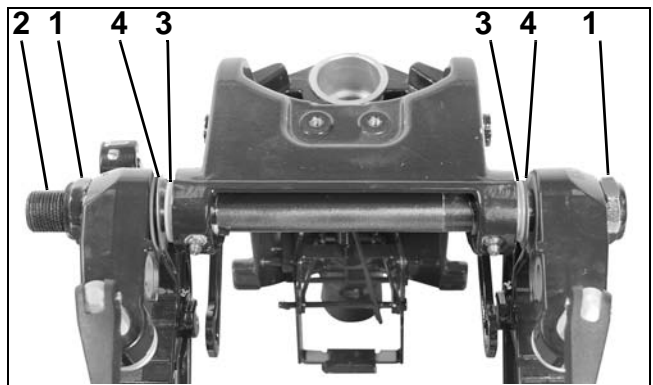

1. Tilt tube nuts  
 2. Tilt tube  
 3. Bushings  
 4. Thrust washers  
 007593

Use an appropriate tool to unhook the two springs from the top of the swivel bracket. Remove the springs.

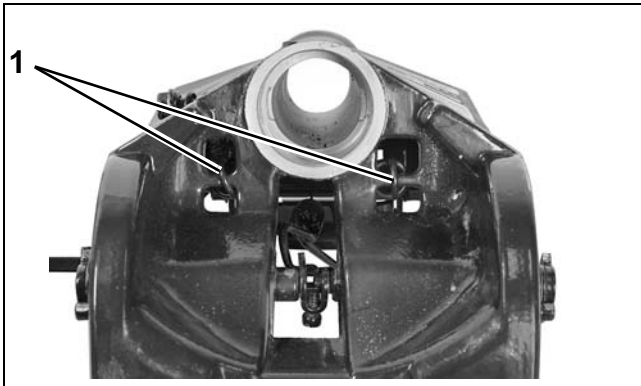

1. Springs

007494

Push down on link. Unhook reverse lock release rod from pin and remove rod from bellcrank.

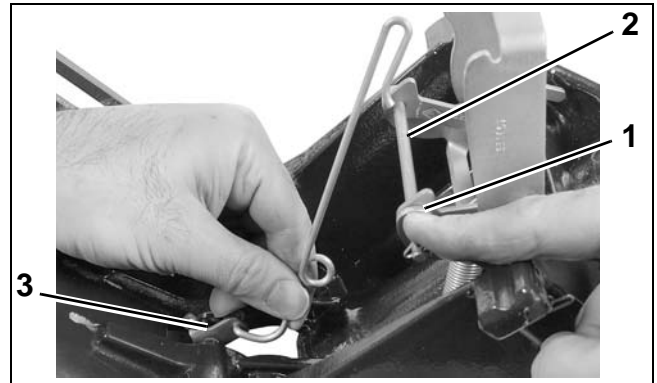

1. Link  
2. Pin  
3. Bellcrank

007597

Unhook spring from reverse lock release rod.

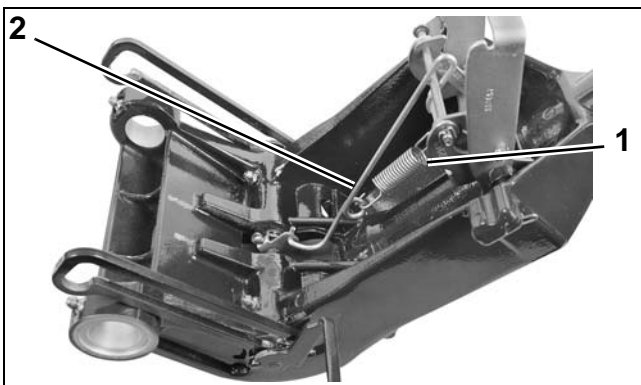

1. Spring  
2. Reverse lock release rod

007595

Remove the bellcrank, tilt lock lever, and port stop link from the swivel bracket

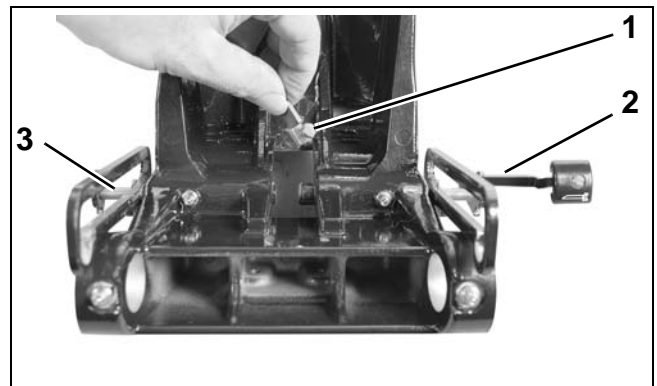

1. Bellcrank  
2. Tilt lock lever  
3. Stop link

007598

Place the tilt/run lever in the RUN position. Loosen the bellcrank setscrew.

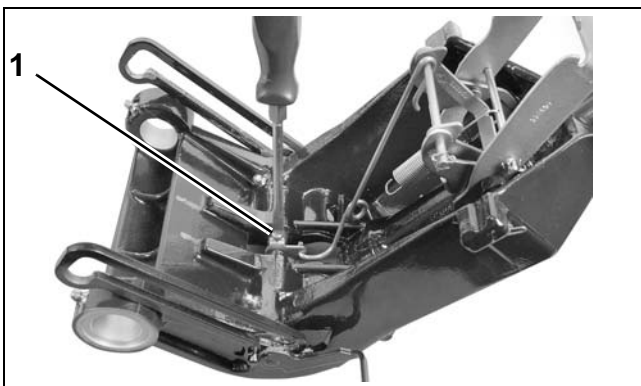

1. Bellcrank setscrew

007596

**MIDSECTION**  
**STERN BRACKET – MANUAL TILT MODELS**

Remove retaining clips from both sides of the swivel bracket.

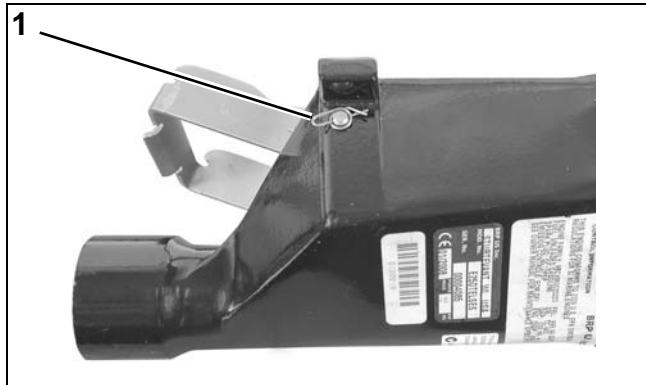

1. *Clip* 007599

Remove the shallow water drive link and reverse lock assembly from the swivel bracket.



007601

Remove pins from shallow water drive link and swivel bracket. Use care not to lose spring.

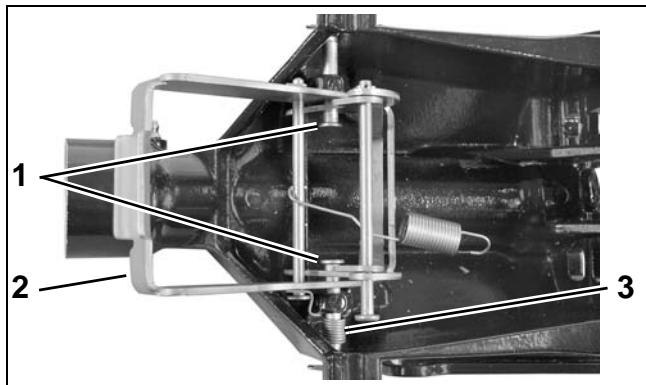

1. *Pins*  
 2. *Shallow water drive link*  
 3. *Spring* 007600

Remove cotter pins and disassemble shallow water drive and reverse lock assembly as needed.

If tilt lock assembly requires replacement, use an appropriate tool to remove bushing from swivel bracket.

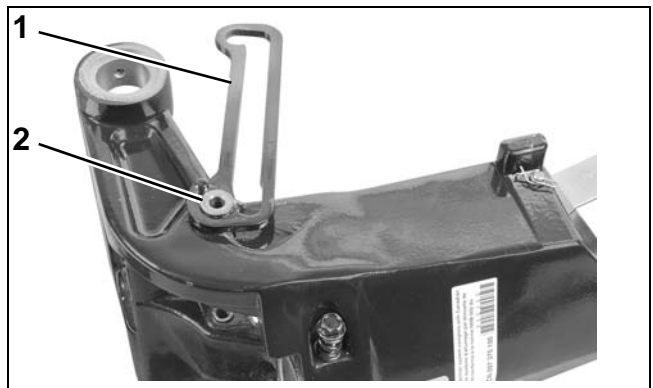

1. *Tilt lock assembly*  
 2. *Bushing* 007602

### Stern Bracket Assembly (Manual Tilt)

Install a new bushing through hole in tilt lock assembly. Press bushing into swivel bracket until fully seated. Make sure tilt lock assembly moves freely.

**IMPORTANT:** Prevent damage to the tilt lock assembly stop pin. Be sure to properly support the swivel bracket when pressing in bushings.

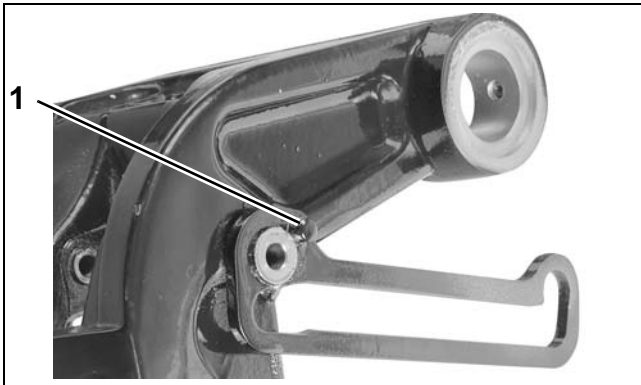

1. Stop pin

007629

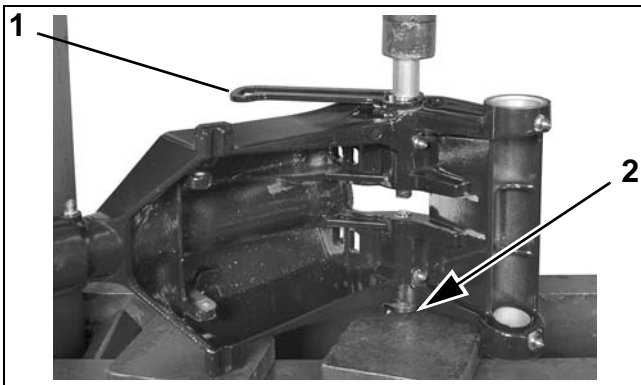

1. Tilt lock assembly  
2. Correct support

007603

Assemble reverse lock link and reverse lock lever as shown. Install pin and secure with new cotter pin.

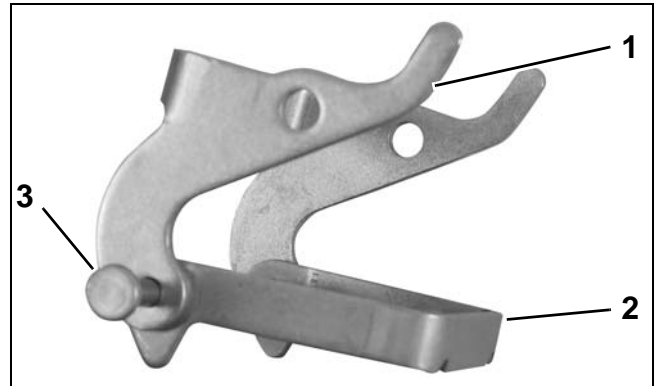

1. Reverse lock link  
2. Reverse lock lever  
3. Pin

007604

Place pin through the shallow water drive link as shown. Secure with new cotter pin.

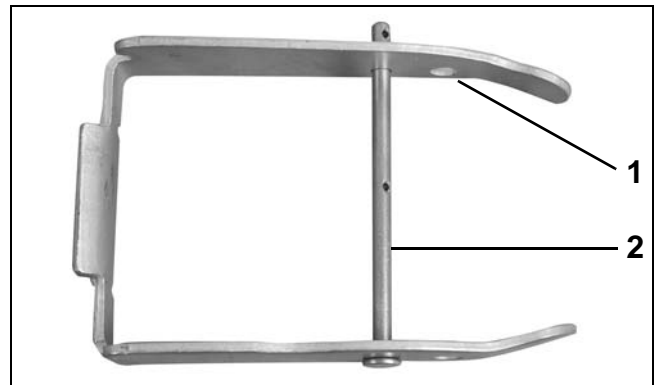

1. Shallow water drive link  
2. Pin

007630

Align reverse lock link assembly with shallow water drive link as shown.

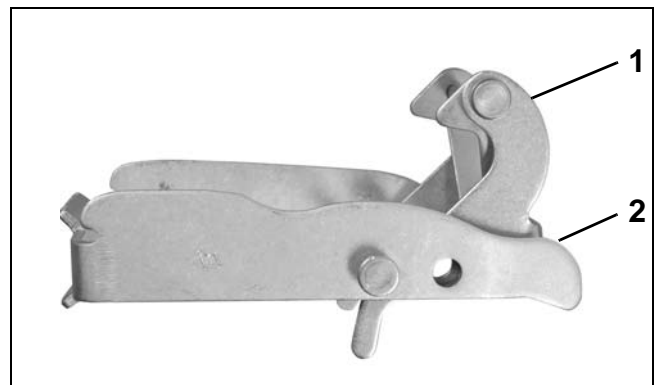

1. Reverse lock link assembly  
2. Shallow water drive link

007605

**MIDSECTION**  
**STERN BRACKET – MANUAL TILT MODELS**

Place the shallow water drive link and reverse lock assembly into the swivel bracket as shown. Install one pin as shown and secure pin with clip.

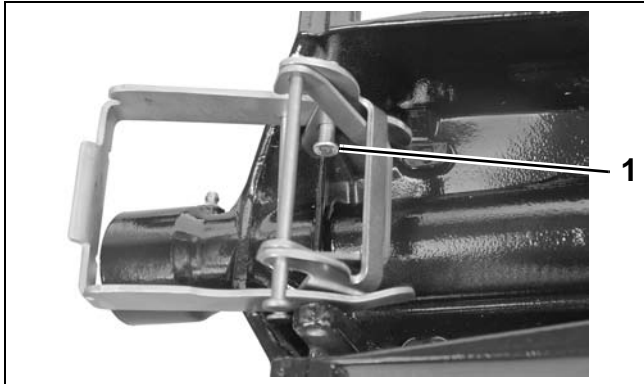

1. Pin 007606

Install remaining pin through reverse lock assembly and into boss. Use an appropriate tool to hold spring in alignment. Push pin through spring and swivel bracket. Secure pin with clip.

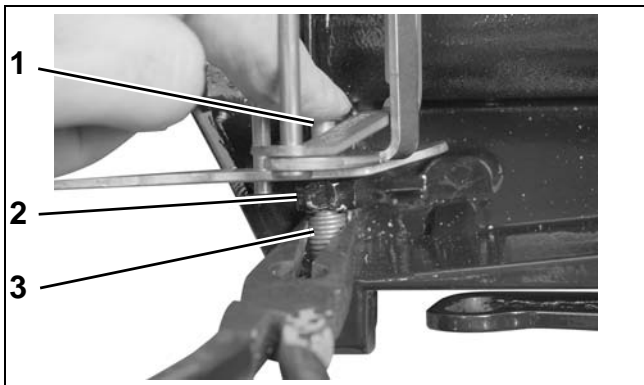

1. Pin 007607  
 2. Boss  
 3. Spring

**IMPORTANT:** Make sure the rounded end of the spring is installed as shown.

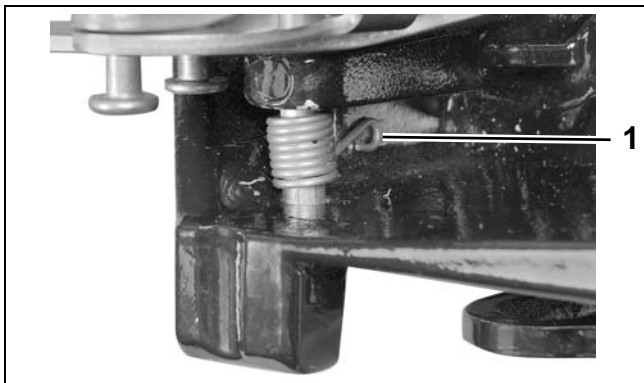

1. Spring rounded end 007608

Use an appropriate tool to hook the straight end over the pin as shown.

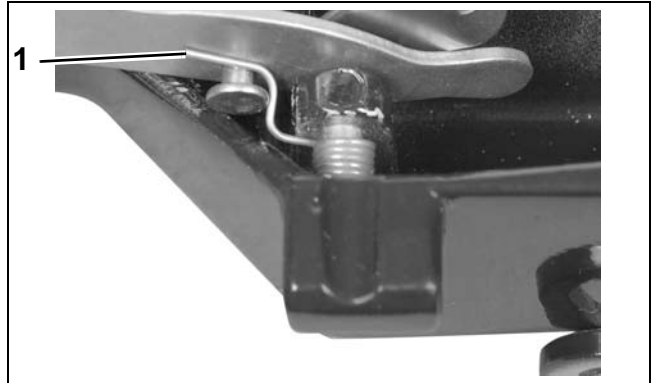

1. Spring straight end 007609

Install the tilt lock lever and port stop link in the swivel bracket. Install the bellcrank, temporarily leave the bell crank screw loose.

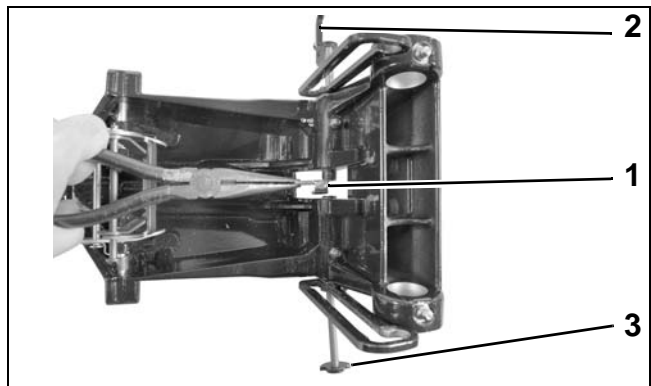

1. Bellcrank 007610  
 2. Tilt lock lever  
 3. Stop link

Be sure the tilt lock lever cam and port stop link cam are installed as shown.

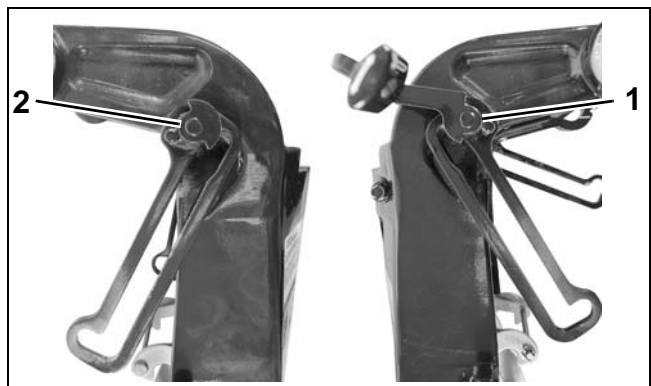

1. Port stop link cam 007611  
 2. Tilt lock lever cam 007612



Install reverse lock release rod on bellcrank. Connect rod to pin as shown.

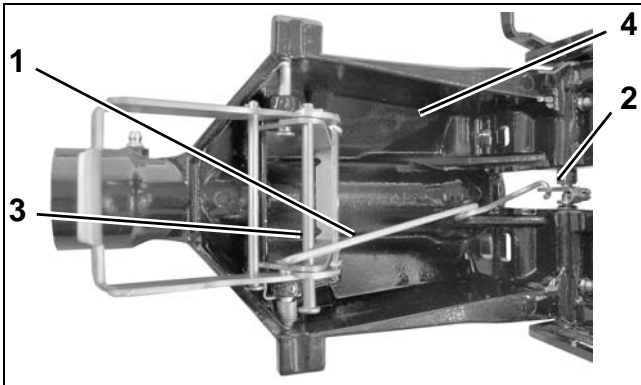

1. Reverse lock release rod  
2. Bellcrank  
3. Pin  
007613

Tighten the bellcrank setscrew to a torque of 35 to 61 in. lbs. (4 to 7 N·m).

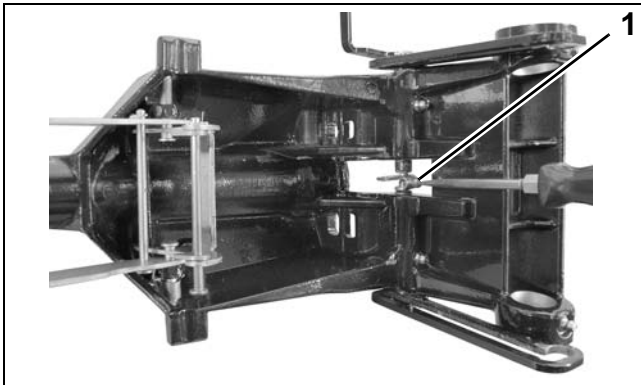

1. Bellcrank setscrew  
007614

Connect the hook end of spring to the reverse lock release rod.

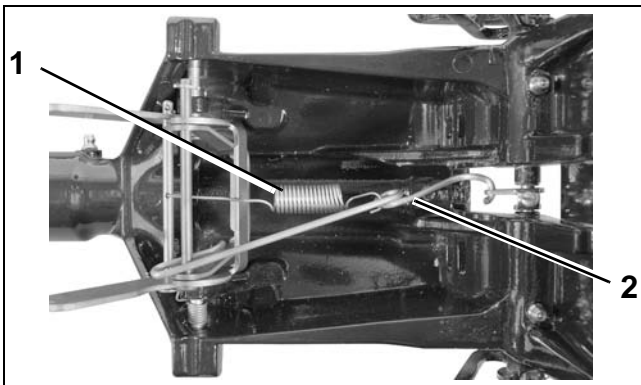

1. Spring  
2. Reverse lock release rod  
007615

Attach the two reverse lock springs to the reverse lock lever.

Use an appropriate tool to connect the reverse lock springs to the top of the swivel bracket.

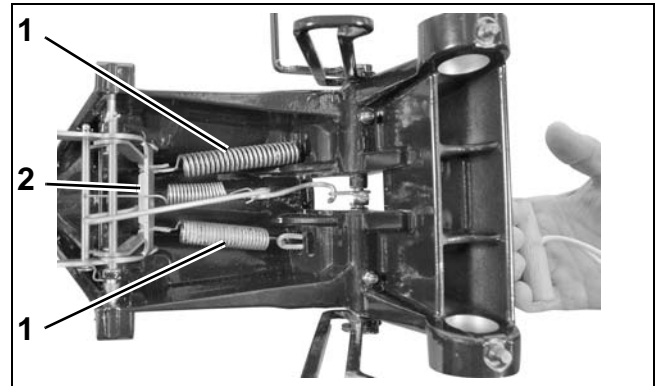

1. Springs  
2. Reverse lock lever  
007616

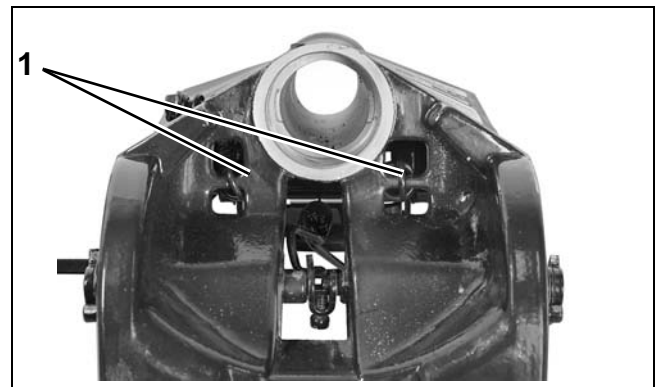

1. Springs  
007594

Install tilt tube, bushings, thrust washers, handle and stern brackets.

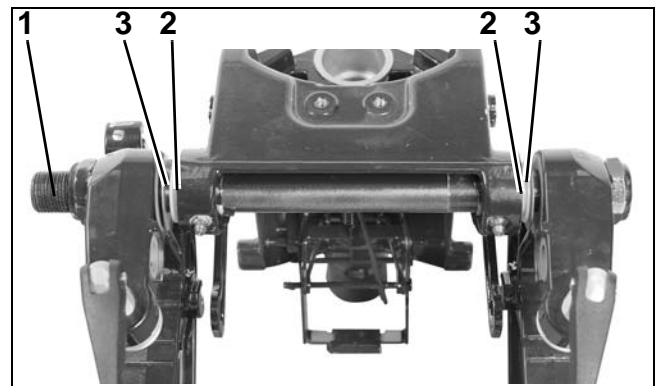

1. Tilt tube  
2. Bushings  
3. Thrust washers  
007593

## MIDSECTION

### STERN BRACKET – MANUAL TILT MODELS

Install pin through each lock assembly and stern bracket. Install washers and nuts, and tighten to a torque of 18 to 20 ft. lbs. (24.5 to 27 N·m).

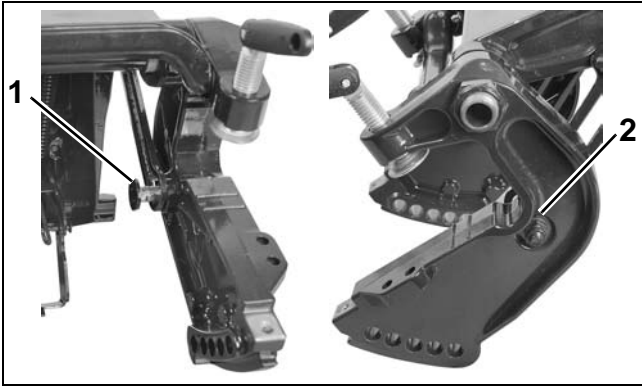

- 1. Pin
- 2. Nut and washer

007592  
007591

Apply *Ultra Lock* to the threads of the tie bar screws. Install the screws and tighten to a torque of 144 to 168 in. lbs. (16 to 19 N·m). Install the tilt pin.

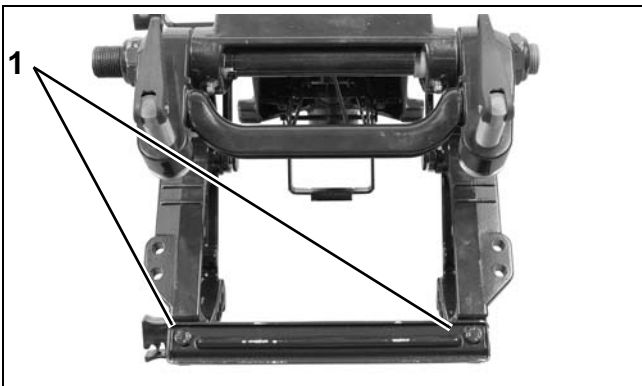

- 1. Tie bar screws

007590

Tighten the tilt tube nuts to a torque of 40 to 45 ft. lbs. (54 to 61 N·m), then back off 1/8 to 1/4 turn.

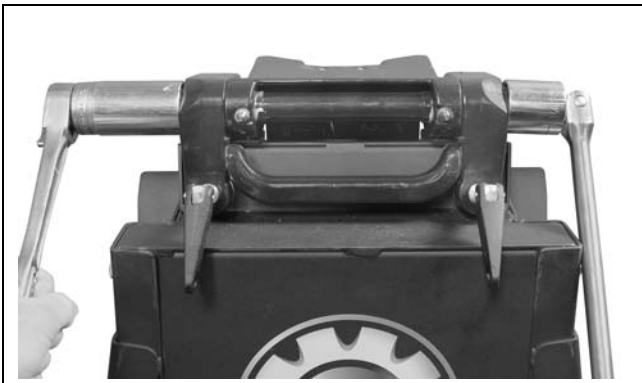

007589

Install friction screw and spring in swivel bracket.

Apply a light coat of *Triple-Guard* grease to the outside of the upper bushing.

Install upper bushing. Make sure bushing slots are aligned with slots in swivel bracket.

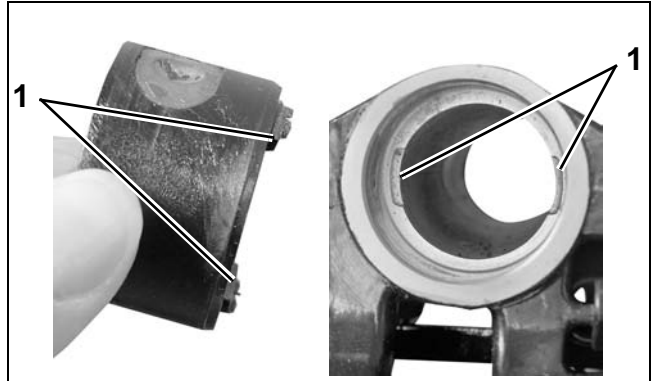

- 1. Slots

007619  
007620

Make sure friction plate is aligned toward friction screw.

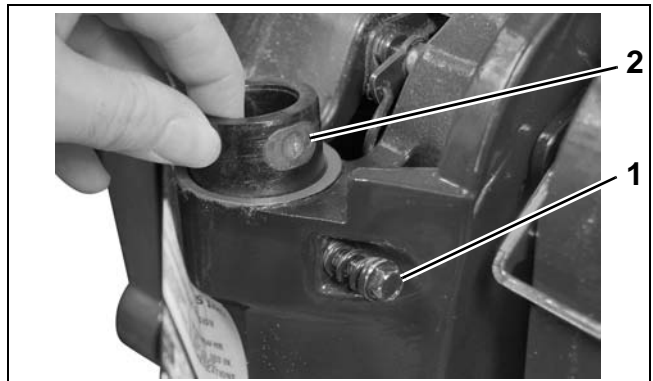

- 1. Friction plate
- 2. Friction screw

007618

STERN BRACKET – MANUAL TILT MODELS

Apply a light coat of *Triple-Guard* grease to the outside of the lower bushing. Install bushing in the swivel bracket.



1. Lower bushing 007588

Use Seal Installation tool, P/N 350958, to install new upper and lower seals in the swivel bracket. Install seals with lips of seals facing in.

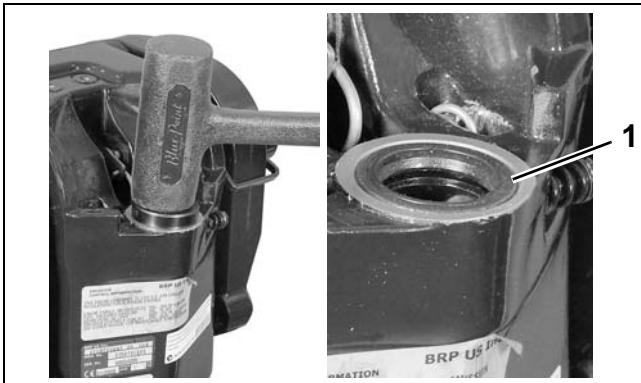

1. Seal 007621  
007622

Install the steering friction plate, washers and lever.

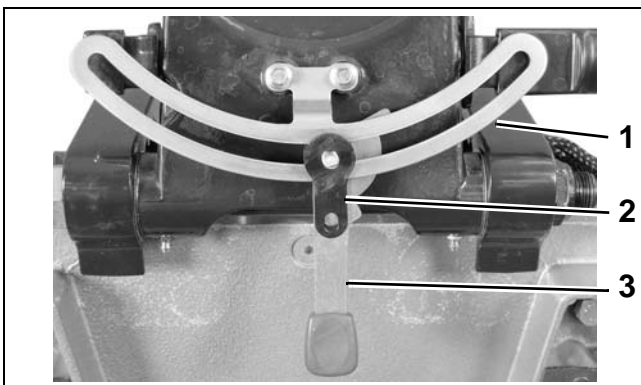

1. Steering friction plate 007686  
2. Steering friction washers  
3. Steering friction lever

Apply *Triple-Guard* grease to both sides of thrust washer. Install thrust washer on steering arm.

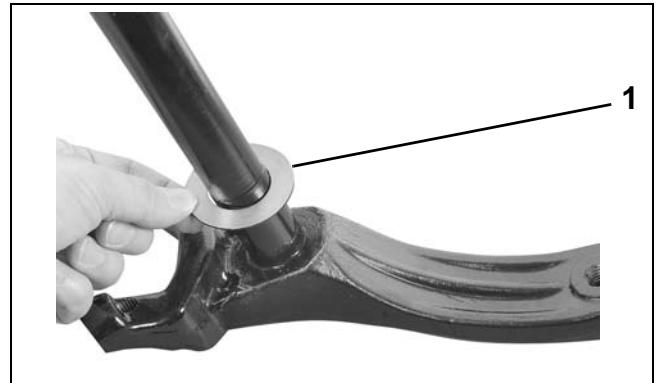

1. Thrust washer 007617

Slide the steering arm through the swivel bracket.

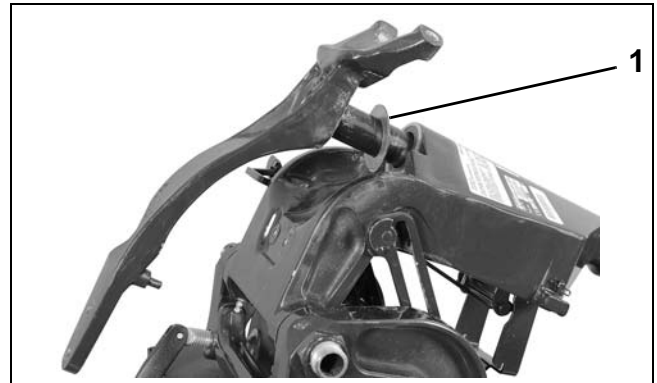

1. Thrust washer 007623

Align slots of friction washers with dowel pin.

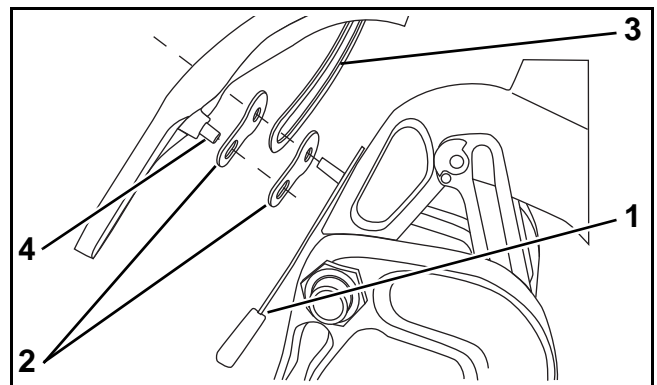

1. Steering friction lever 007491  
2. Friction washers  
3. Friction plate  
4. Dowel pin

## MIDSECTION

### STERN BRACKET – MANUAL TILT MODELS

Align dowel pin and steering friction lever as shown.

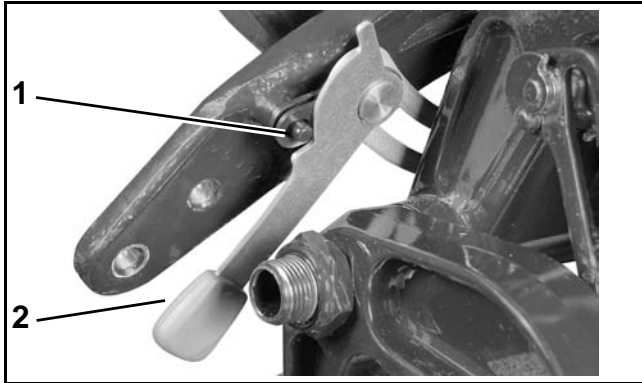

5. Dowel pin  
6. Steering friction lever

007458

Install locking nut. Temporarily tighten locking nut three to four full turns. Final adjustment will be performed later.

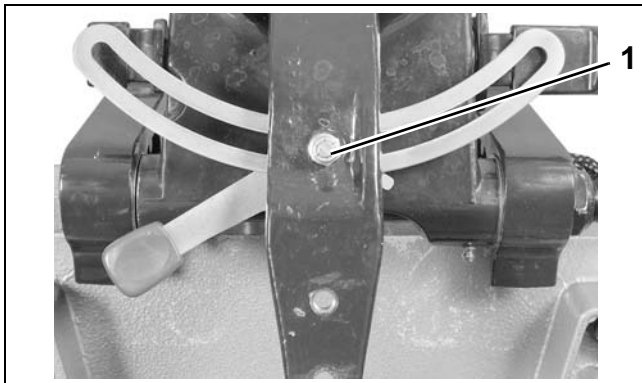

1. Steering friction nut

007684

Lubricate the swivel bracket through the four lubrication fittings with *Triple-Guard* grease.

Apply *Triple-Guard* grease to both sides of thrust washer. Install thrust washer on steering arm.

Install lower mount bracket on steering arm.

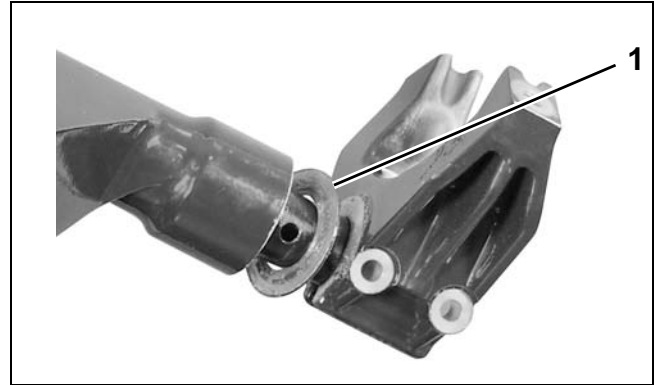

1. Thrust washer

007624

Install lower mount retaining screws. Tighten screws to a torque of 10 to 12 ft. lbs. (14.5 to 16.5 N·m).

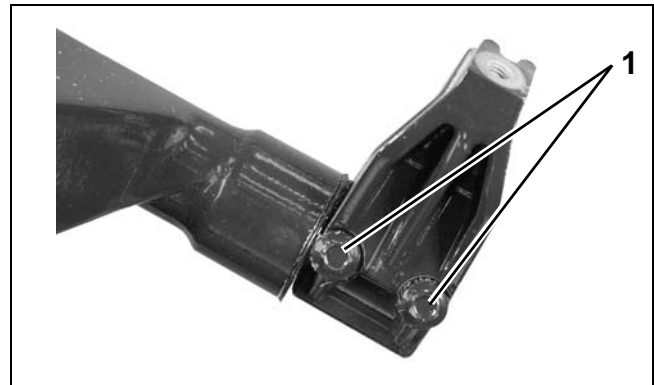

1. Retaining screws

007582

Install exhaust housing. Refer to **EXHAUST HOUSING SERVICE** on p. 203.

Install tiller handle. Refer to **TILLER HANDLE SERVICE** on p. 227.

Adjust tiller steering friction. Refer to **Steering Friction Adjustment** on p. 24.

# TILLER HANDLE SERVICE

## Removal

**⚠ WARNING**

To avoid accidental starting of engine while servicing, twist and remove all spark plug leads.

Remove lower engine covers. Refer to **Lower Cover Removal** on p. 45.

Disconnect tiller electrical connector and trim connector, if equipped.

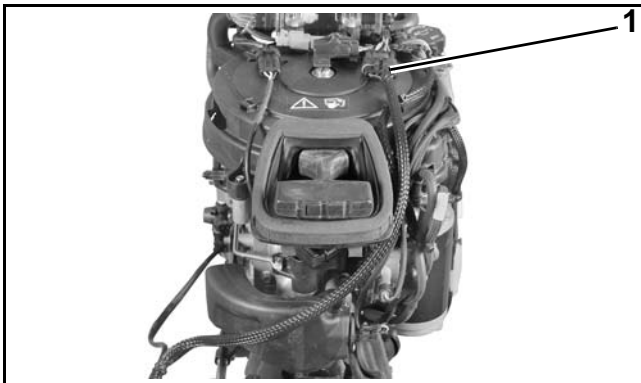

1. Tiller electrical connector 007474

Use Ball Socket Remover Tool, P/N 342226, to remove throttle cable connector from throttle lever. Remove screw and washer from throttle cable retainer.

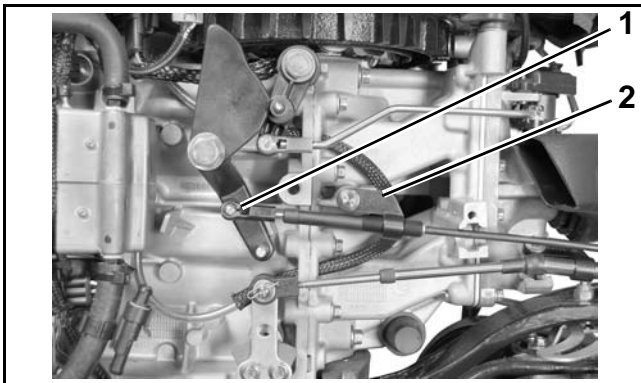

1. Throttle cable connector 007471  
2. Throttle cable retainer

Remove clip and washer from shift lever pin and remove shift cable connector from shift lever pin. Remove cable anchor screw and washer from shift cable retainer.

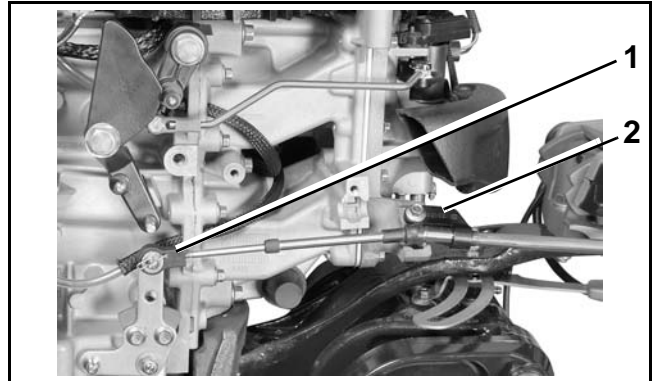

1. Shift cable connector 007467  
2. Shift cable retainer

Remove locknuts from screws on bottom of steering arm.

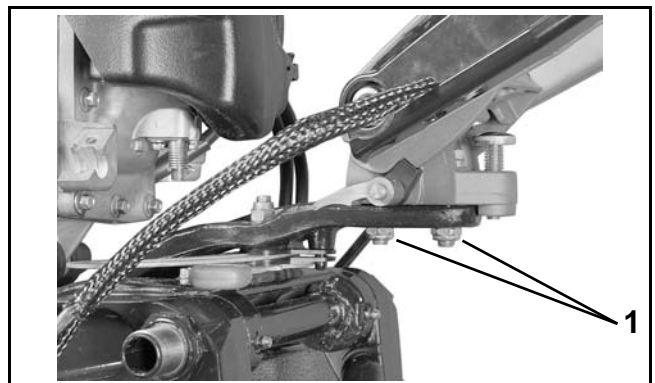

1. Locknuts 007462

Remove front steering handle screw and washer.

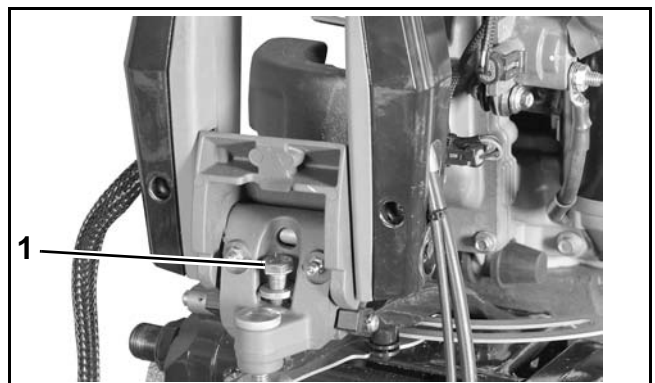

1. Front steering arm screw and washer 007460

# MIDSECTION

## TILLER HANDLE SERVICE

Remove rear steering handle screw and washer.

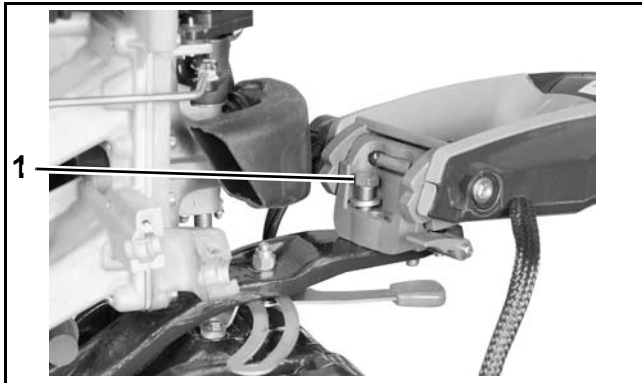

1. Rear steering arm screw and washer 007461

Remove tiller handle assembly.

### Disassembly

Loosen throttle friction control so there is no restriction on grip.

**IMPORTANT:** Do not back screw out completely. Nut is under spring tension.

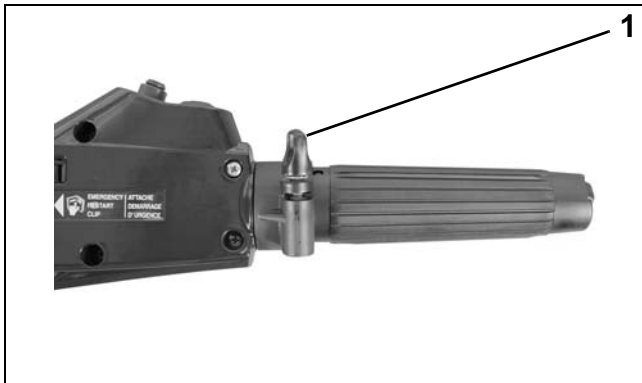

1. Throttle friction control 007527

Remove eight screws and bottom cover of tiller handle.

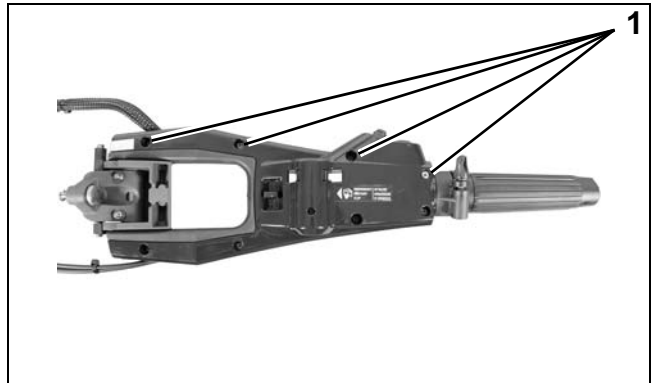

1. Cover screws 007528

Remove shift handle screw and shift handle.

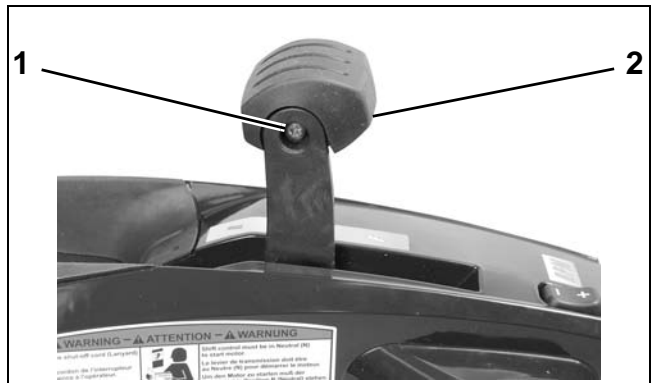

1. Screw  
2. Shift handle 007529

Remove stop switch screws. Loosen start switch nut.

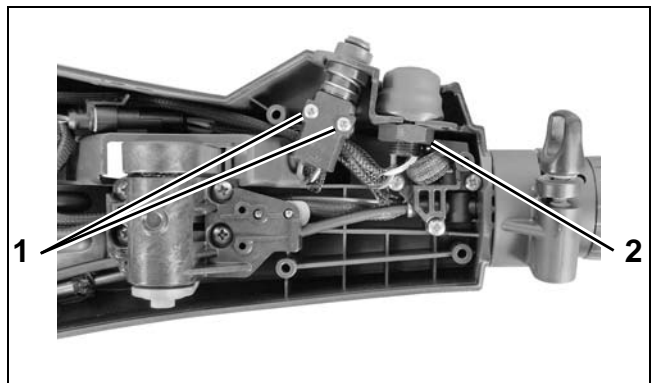

1. Screws  
2. Start switch nut 007530

Remove start switch, stop switch, housing, spring, button, and spacer.

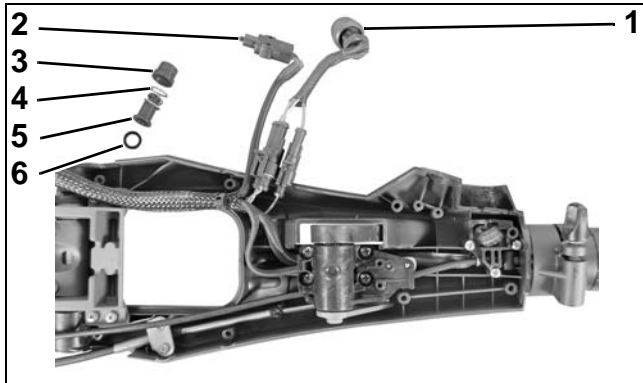

- 1. Start switch
  - 2. Stop switch
  - 3. Housing
  - 4. Spring
  - 5. Button
  - 6. Spacer
- 007531

Disconnect start switch connectors. If replacing trim switch, remove tie straps from harness and remove connectors from trim switch wires. Refer to **CONNECTOR SERVICING** on p. 111.

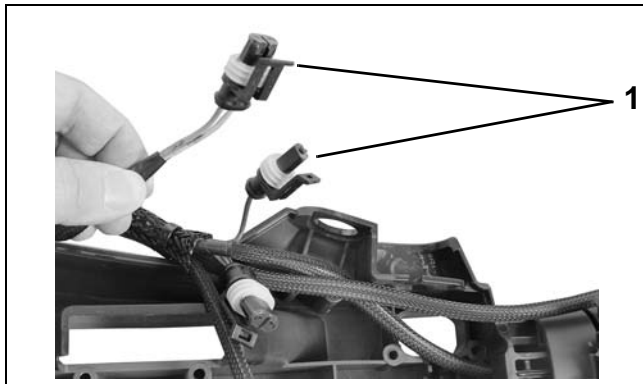

- 1. Trim switch wire connectors
- 007533

Remove shift cable retainer.

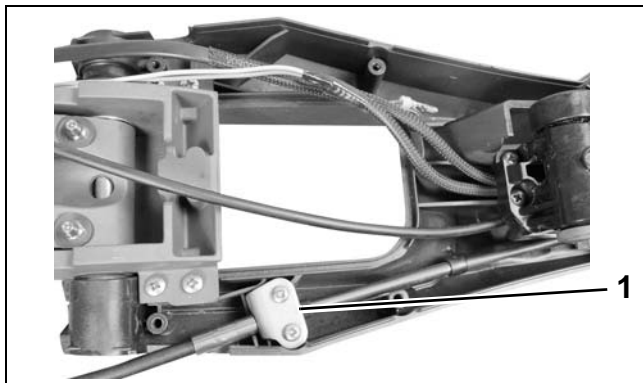

- 1. Shift cable retainer
- 007534

Remove screw and washer from shift link. Remove shift cable and shift link.

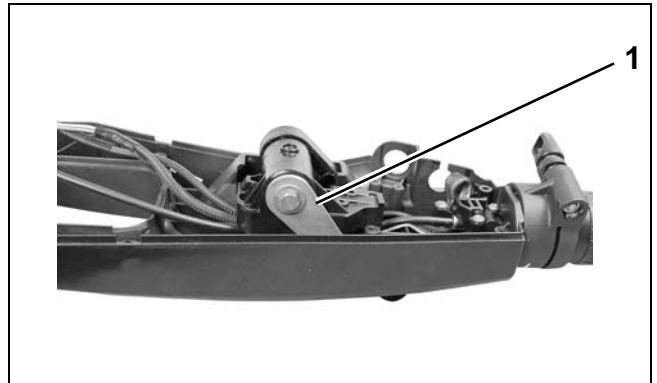

- 1. Shift link
- 007535

Remove cotter pin from shift link and remove shift cable.



- 1. Cotter pin
- 007536

Remove four shift lever bracket retaining screws. Remove shift lever bracket.

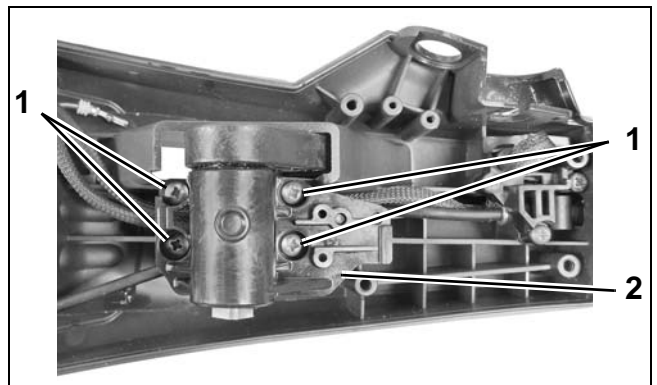

- 1. Screws
  - 2. Shift lever bracket
- 007537



## MIDSECTION TILLER HANDLE SERVICE

Remove two shift detent retaining screws.  
Remove detent spring.

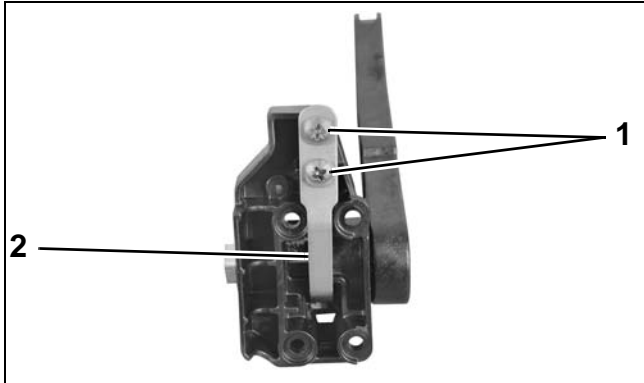

1. Screws
2. Shift detent spring

007538

Use *Twist-Grip Remover*, P/N 390767, to depress the grip detents. Tighten screw and remove the grip by pulling grip.

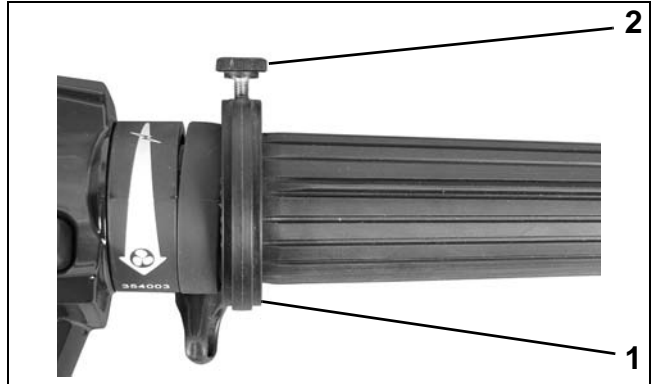

1. Twist-Grip Remover
2. Screw

007541

Remove shift lever from shift bracket.

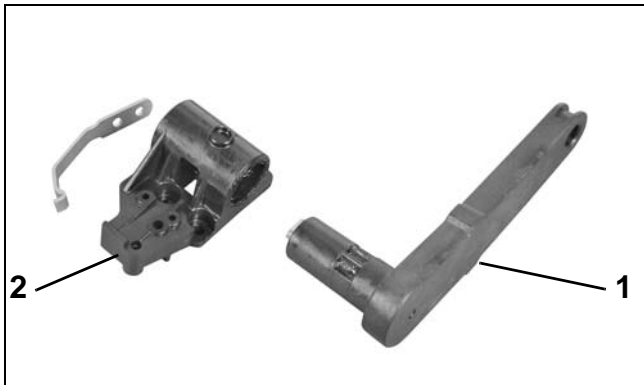

1. Shift lever
2. Shift bracket

007539

Remove the helix halves, rollers, and guides.

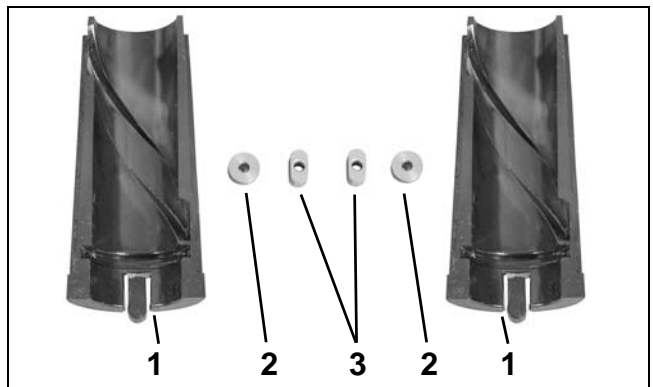

1. Helix halves
2. Rollers
3. Guides

007542

Remove the Touch Troll switch bracket retaining screws. Remove the Touch Troll switch and bracket.

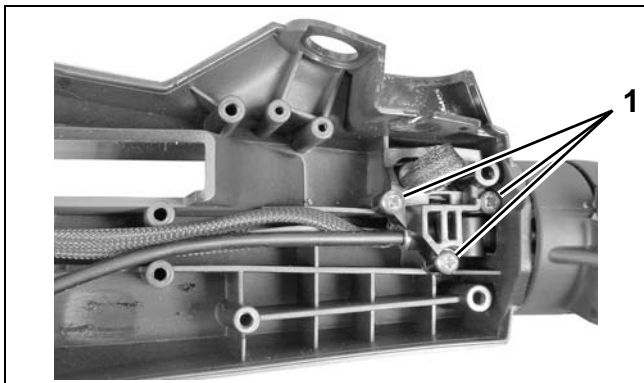

1. Screws

007540

Pull the throttle pin out of the cable.



007543



Remove the throttle cable.

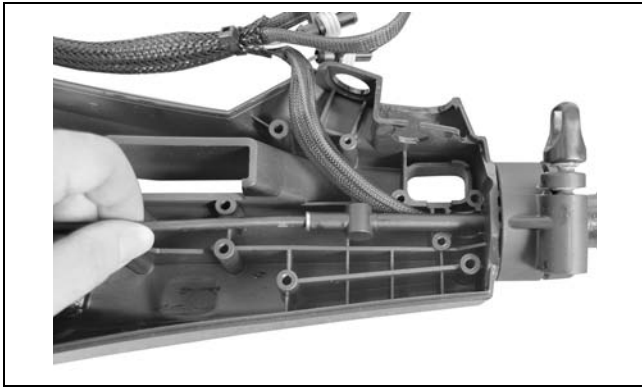

007544

The twist grip and trim switch wiring can now be removed from the inner handle.

Use an appropriate tool to carefully pry the trim switch out of the twist grip.



007545

Remove the throttle friction control.

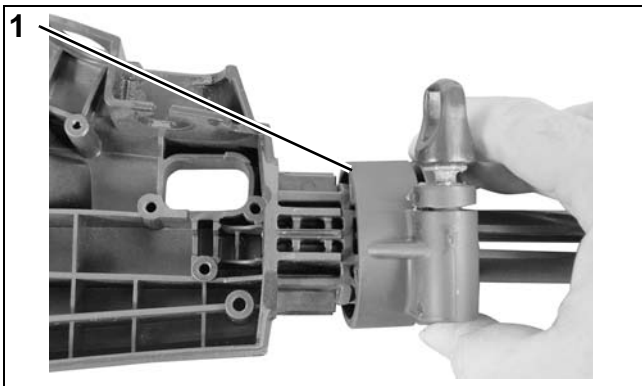

1. Throttle friction control

007546

Remove nut, washer and bushing from port side of tiller handle.

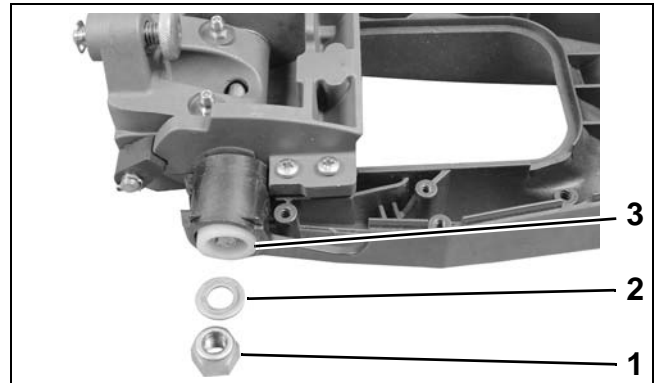

1. Nut
2. Washer
3. Bushing

007547

Remove steering handle screw.



1. Steering handle screw

007548

Remove base from tiller handle. Remove two bushings from base.

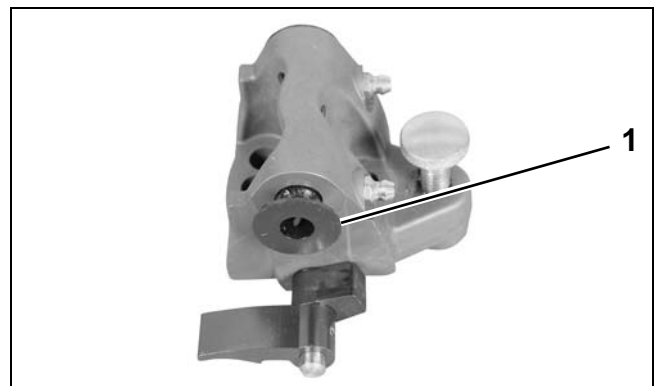

1. Bushing

007549

## MIDSECTION TILLER HANDLE SERVICE

If replacing tilt detent pawl, tilt release lever, tilt detent pin or spring, remove cotter pin and roll pins as needed.

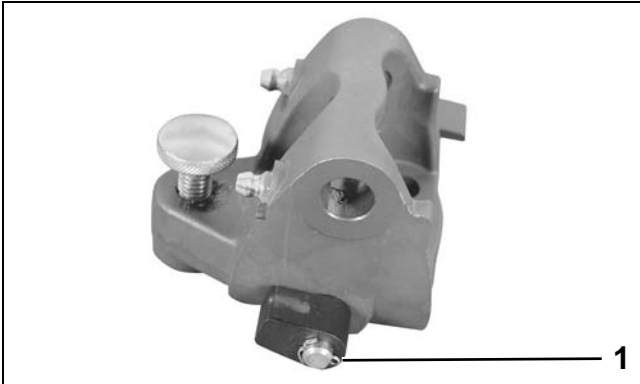

1. Cotter pin

007550

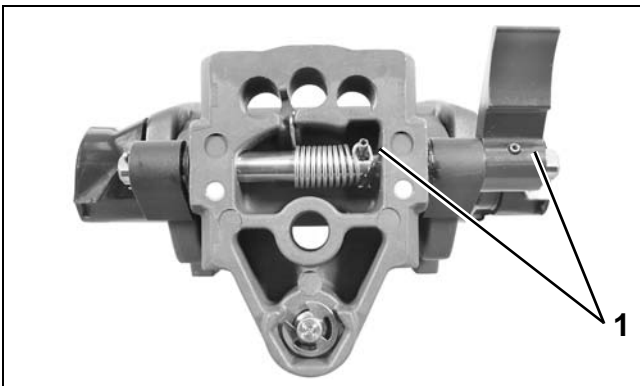

1. Roll pins

007551

Remove four screws and bushing from bracket. Remove bracket from handle.

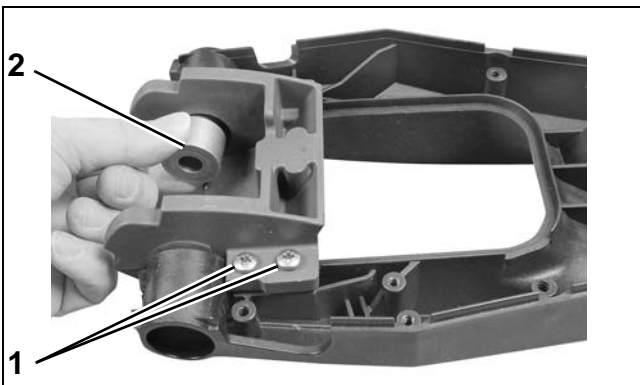

1. Screws  
2. Bushing

007552

## Inspection

Inspect the throttle cable for kinks and wear. Replace if necessary.

Inspect the shift cable for kinks and wear. Replace if necessary.

Inspect the steering handle components for wear, cracks, or damage. Replace parts if necessary.

Refer to **Emergency Stop Switch Test** on p. 99 to test stop switch.

## Assembly

Install bracket on handle. Install four screws. Tighten screws securely and install bushing in bracket.

### ⚠ CAUTION

When reinstalling screws in composite materials turn screws **COUNTER-CLOCK-WISE** until threads of screw engage threads of screw boss.

Failure to follow this procedure will damage the screw boss threads. Once threads are engaged, tighten screws securely.

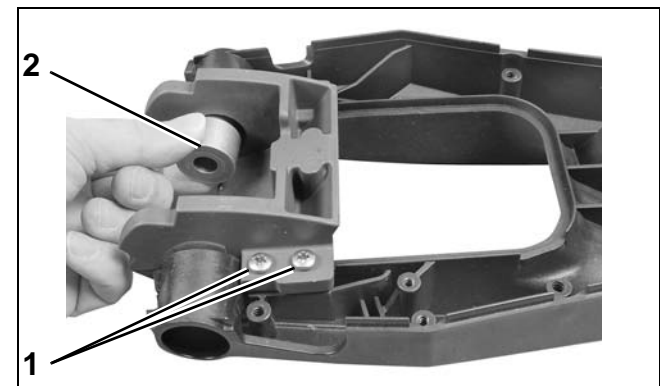

1. Screws  
2. Bushing

007552

Install tilt detent pawl on tilt detent pin. Secure with new cotter pin.

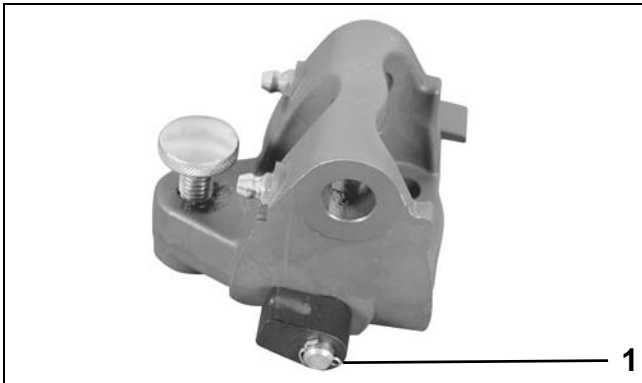

1. Cotter pin

007550

Hook spring to roll pin and recess in base as shown. Turn tilt release lever one turn to apply tension to the spring. Hold lever in position and install base in bracket.

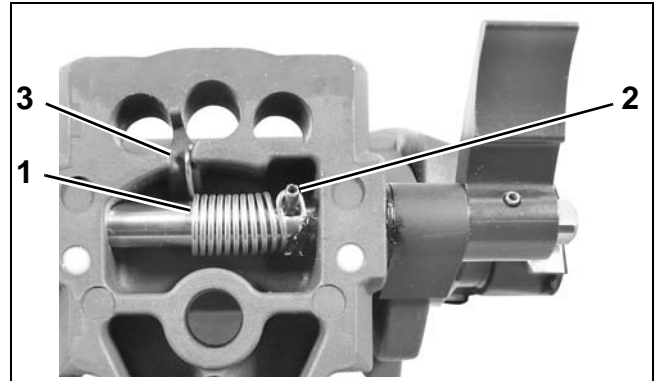

- 1. Spring
- 2. Roll pin
- 3. Recess

007631

Install two bushings in base.

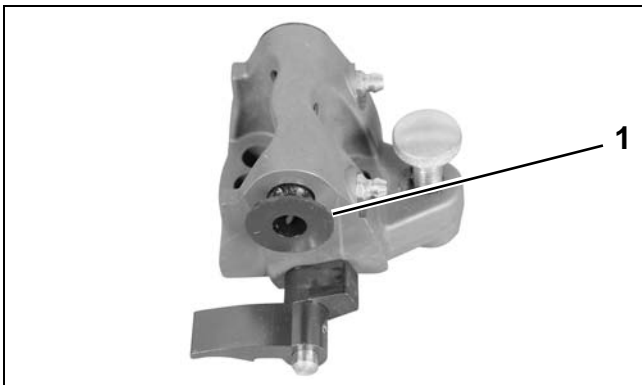

1. Bushing

007549

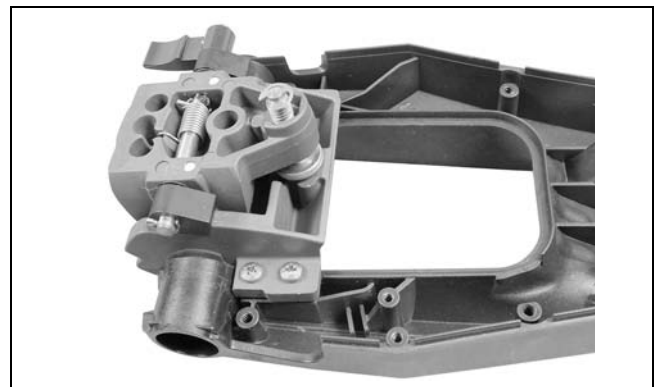

007553

Make sure spring returns tilt release lever.

## MIDSECTION

### TILLER HANDLE SERVICE

Use an appropriate tool to align screw hole through the tiller handle, bracket and base. Install steering handle screw. Tighten screw so tiller handle pivots easily. Refer to **Tiller Handle Friction** on p. 25.



1. Steering handle screw

007548

Install bushing, washer and nut on port side of tiller handle. Tighten nut to a torque of 25 to 28 ft. lbs. (35 to 38 N-m).

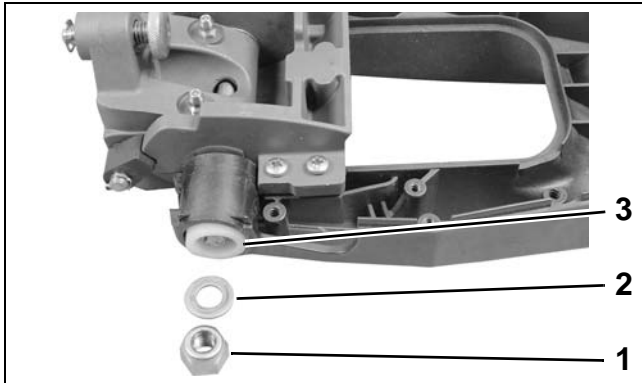

1. Nut
2. Washer
3. Bushing

007547

Install the throttle friction control.

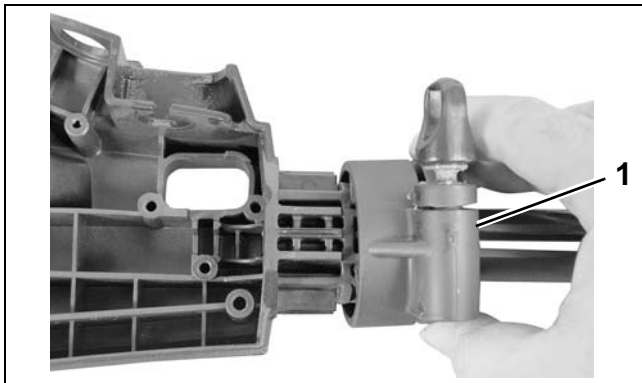

1. Throttle friction control

007546

Press the trim switch into the twist grip. Be sure trim switch UP position aligns with the twist grip indicator line as shown.



1. Trim switch UP position
2. Indicator line

007554

Install trim switch wiring through inner steering handle.

**IMPORTANT:** Trim switch wiring must NOT be twisted through the throttle twist grip or inner tiller handle / wire guide.

Insert wire guide into inner steering handle.

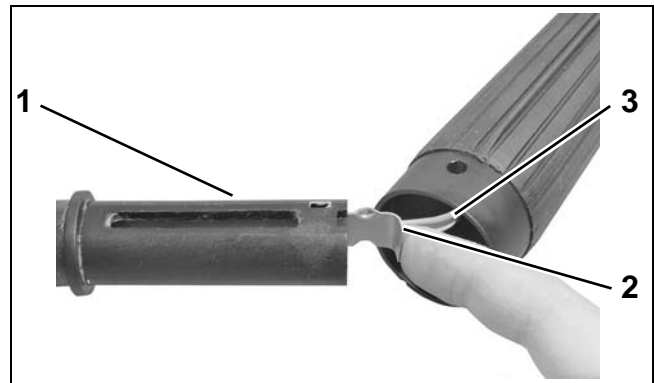

1. Inner tiller handle
2. Wire guide
3. Trim switch wires

007555

Push wire guide into place until locking tab is in place as shown.

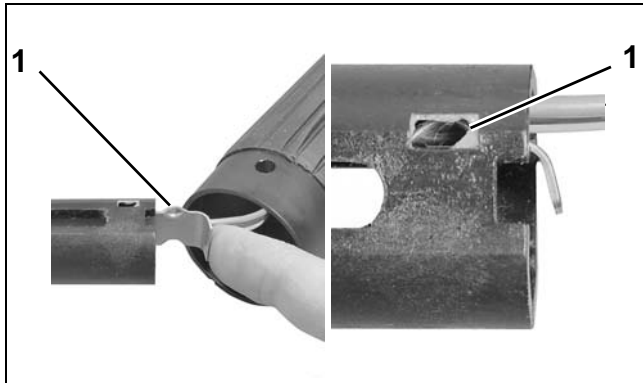

1. Locking tab

007555  
007556

Make sure trim switch wiring is NOT twisted before proceeding.

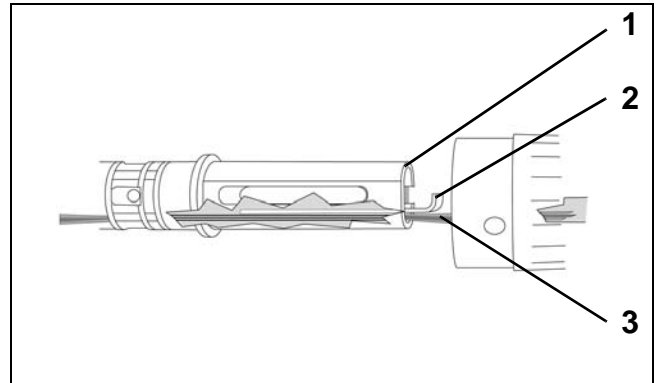

1. Inner tiller handle  
2. Wire guide  
3. Trim switch wires

006675

Wire guide should slide easily into place. If any binding is felt, inspect trim switch wiring for twisting. If wire guide is forced into place, it WILL damage trim switch wiring.

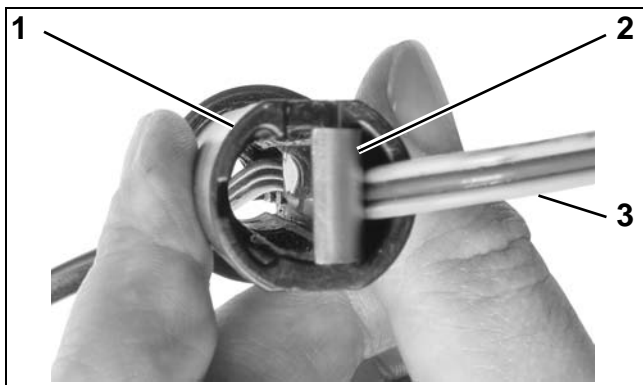

1. Inner tiller handle  
2. Wire guide  
3. Trim switch wires

006684

Install the throttle cable.

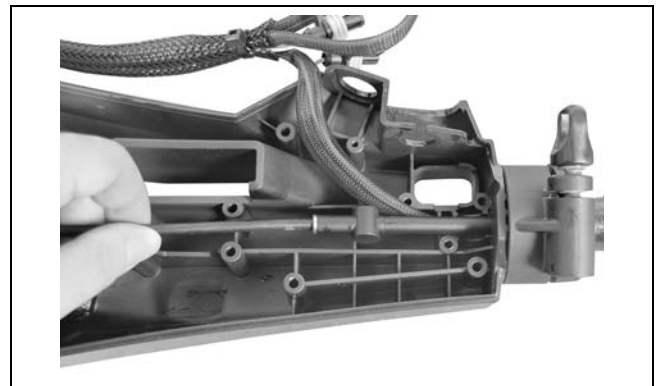

007544

Install the throttle pin in the cable.

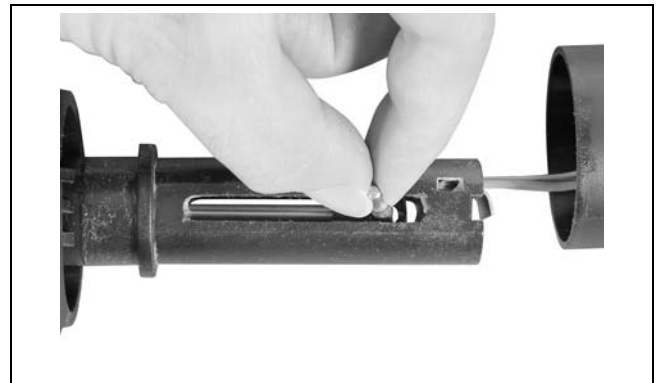

007543

## MIDSECTION

### TILLER HANDLE SERVICE

Apply *Lubriplate* to the ends of pin, guides, rollers, helix grooves and inner handle guide slot. Place the guides over the roller pin and into the slots of the inner handle. Place the rollers on the ends of the roller pin.

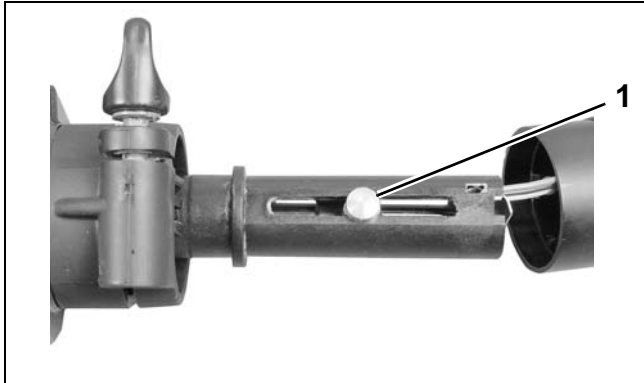

1. Roller

007557

Assemble the helix halves on the handle and slide the grip over the helix.



007558

Carefully pull trim switch wires through inner tiller handle as twist grip assembly is installed.

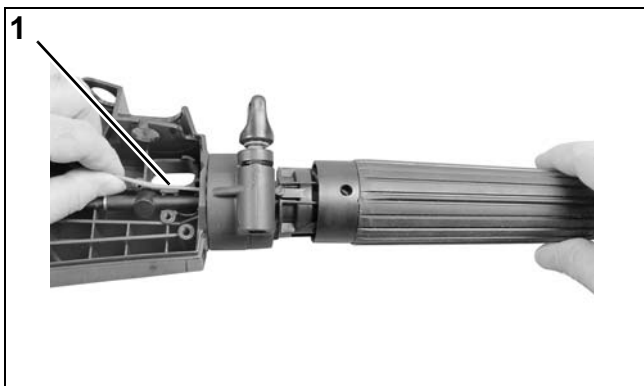

1. Trim switch wiring

007559

Be sure the twist-grip's speed indicator line is positioned with the speed range symbol on the handle. Snap the grip into place.

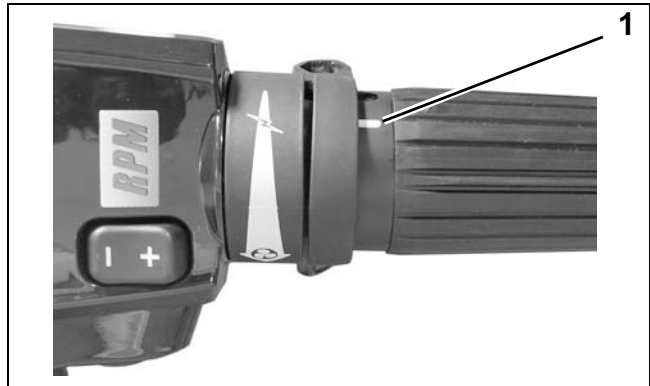

1. Indicator line

007481

Place trim switch wiring under throttle cable as shown.

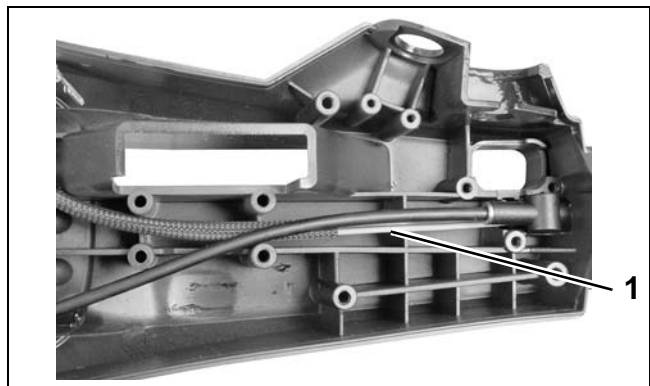

1. Trim switch wiring

007560

Place Touch Troll wiring under throttle cable as shown. Install touch troll switch bracket with three screws. Tighten screws securely.

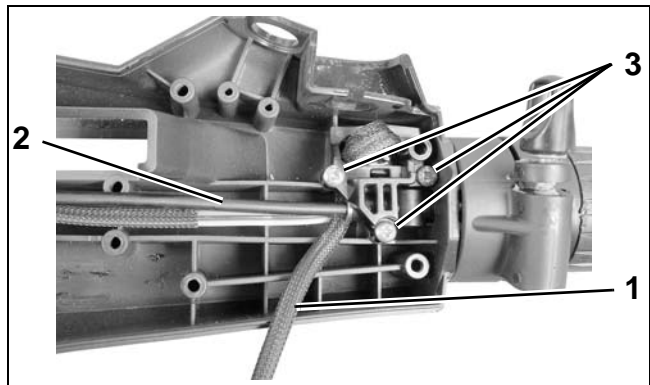

1. Wiring  
2. Throttle cable  
3. Screws

007561

Route wiring under throttle cable as shown.

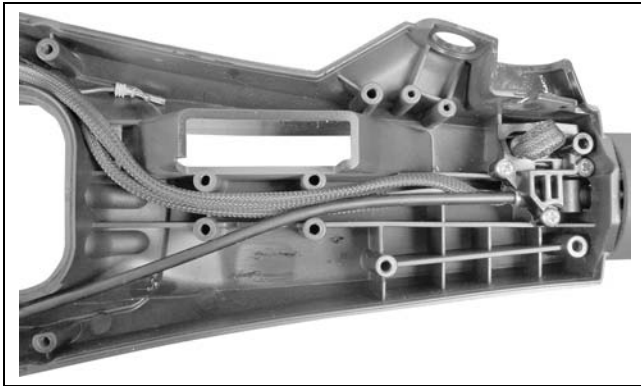

007562

Install shift cable on shift link. Secure with a new cotter pin.



1. Cotter pin

007536

Apply *Lubriplate* to the shaft portion of shift lever. Install shift lever into shift bracket. Install the detent spring with two shift detent retaining screws. Tighten screws securely.

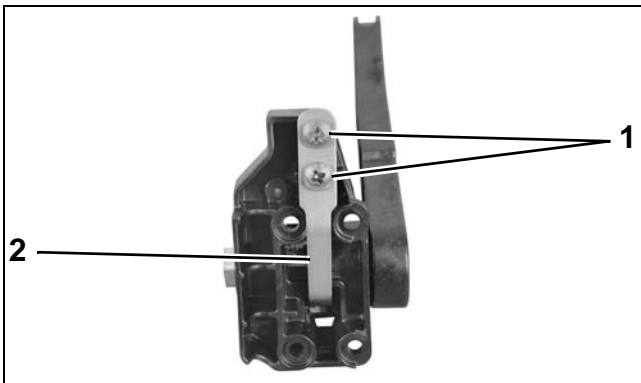

1. Screws  
2. Shift detent spring

007538

Install shift lever assembly. Install four shift lever bracket retaining screws. Tighten screws securely.

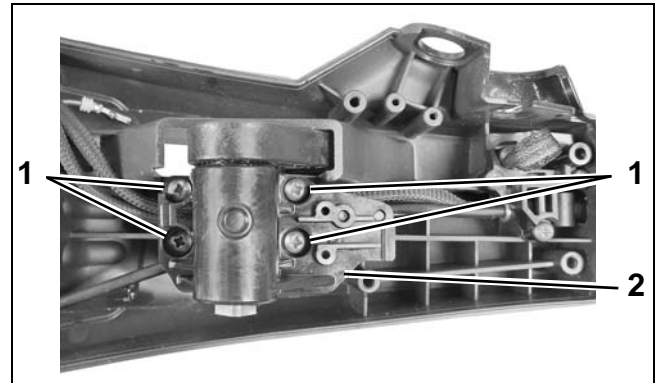

1. Screws  
2. Shift lever bracket

007537

Install shift link and cable on shift lever. Apply *Ultra Lock* to threads of screw and install washer and screw. Tighten screw to a torque of 84 to 106 in. lbs. (9.5 to 12 N·m).

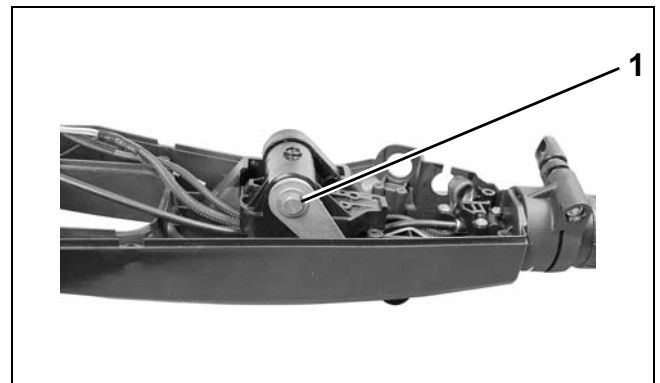

1. Screw and washer

007535

Install shift cable retainer with two screws. Tighten screws securely.

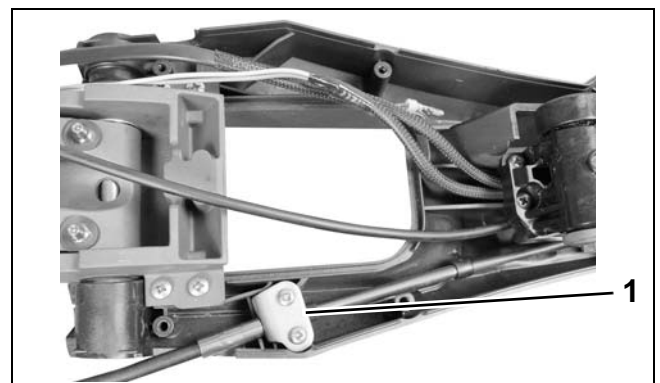

1. Shift cable retainer

007534

## MIDSECTION TILLER HANDLE SERVICE

If trim switch was removed, install tie straps on harness connectors.

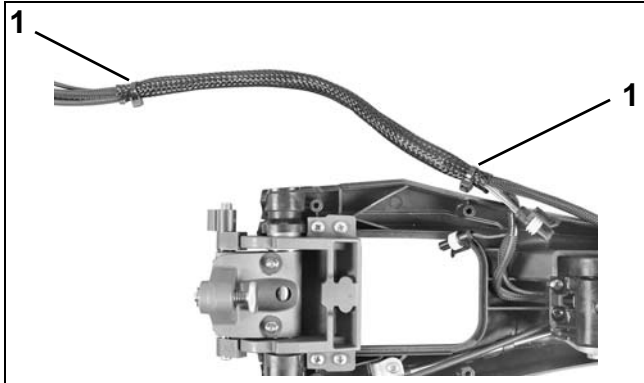

1. Tie straps 007681

Install connectors on trim switch wires. Refer to **CONNECTOR SERVICING** on p. 111. Connect start switch connectors.

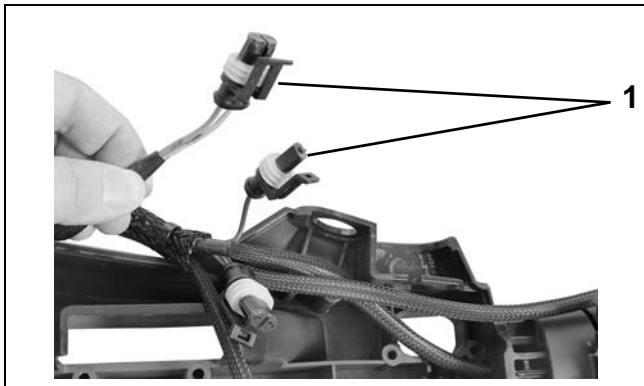

1. Trim switch connectors 007533

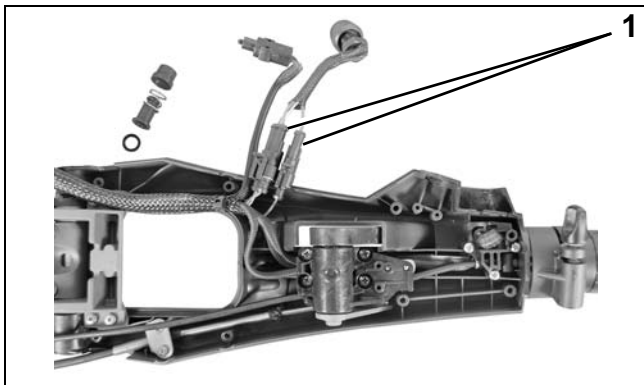

1. Start switch connectors 007531  
007532

Install start switch. Tighten start switch nut securely. Install stop switch housing, spring, button and stop switch. Secure with two screws. Tighten screws securely.

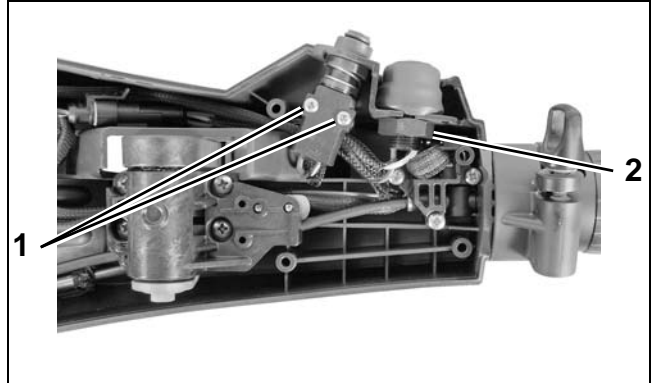

1. Screws 007530  
2. Start switch nut

Route shift and throttle cables, and wiring harness as shown.

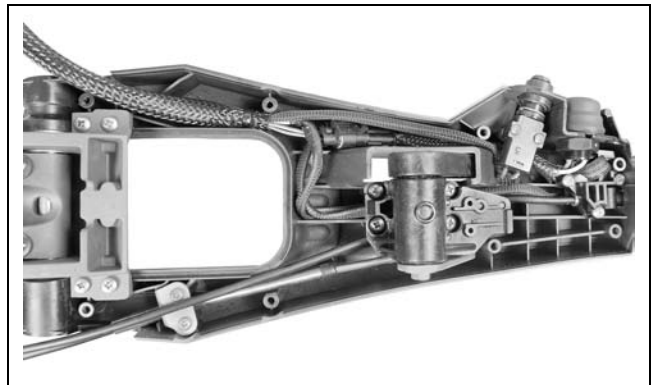

1. Screws 007563  
2. Start switch nut

Install bottom cover of tiller handle with eight screws. Tighten screws securely.

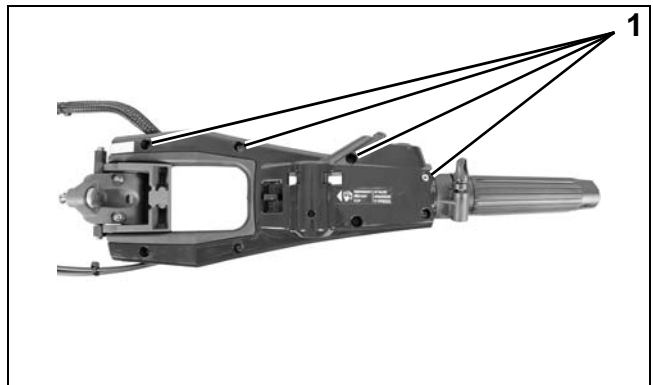

1. Cover screws 007528



Install shift handle. Install shift handle screw. Tighten screw securely.

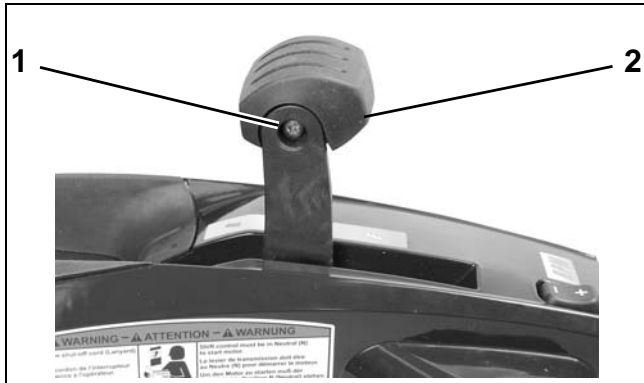

1. Screw  
2. Shift handle  
007529

**Installation**

Place tiller bracket on steering arm.

Install screw and washer in front mounting hole.

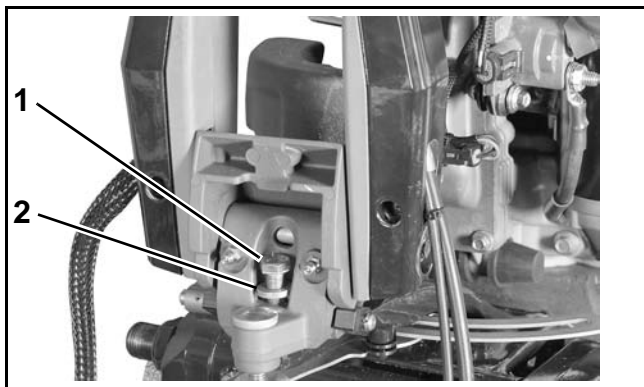

1. Screw  
2. Washer  
007460

The tiller handle angle can be set to center or angled to port or starboard 20°.

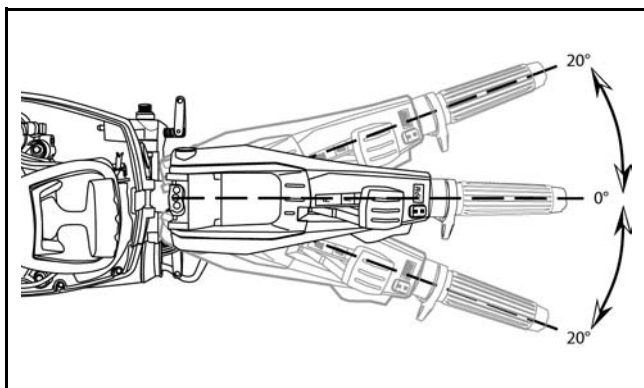

007214

Install rear washer and screw in appropriate location.

Tighten both screws to a torque of 18 to 20 ft. lbs. (25 to 27 N·m).

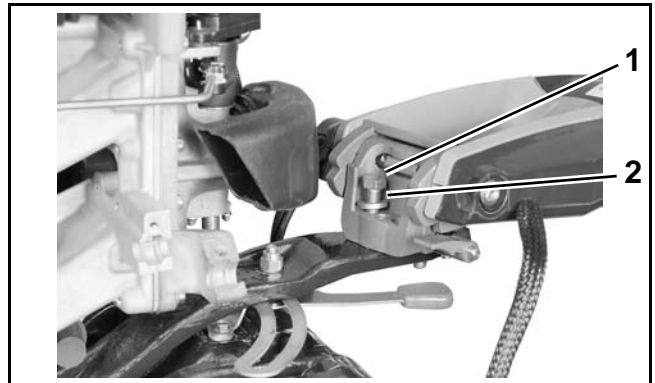

1. Screw  
2. Washer  
007461

Install locknuts on screws.

Hold screws with a wrench and tighten locknuts to a torque of 18 to 20 ft. lbs. (25 to 27 N·m).

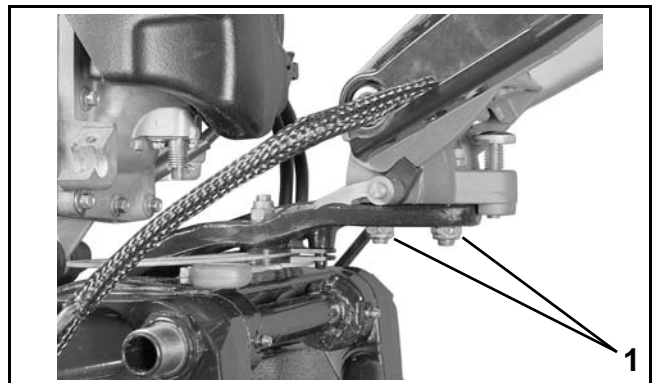

3. Locknuts  
007462

Route tiller control wiring as shown.

## MIDSECTION

### TILLER HANDLE SERVICE

Connect tiller electrical connector. Secure to retainer on starter housing.

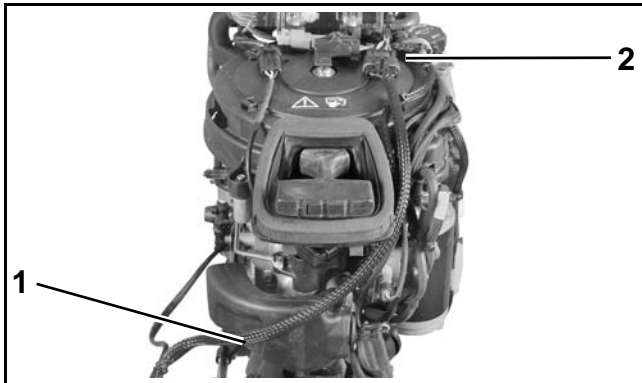

1. Wire routing  
2. Retainer  
007474

Place battery cables and trim wiring through hole in port lower motor cover.

Route trim wiring as shown.

Connect electrical connector and use tie strap to secure as shown.

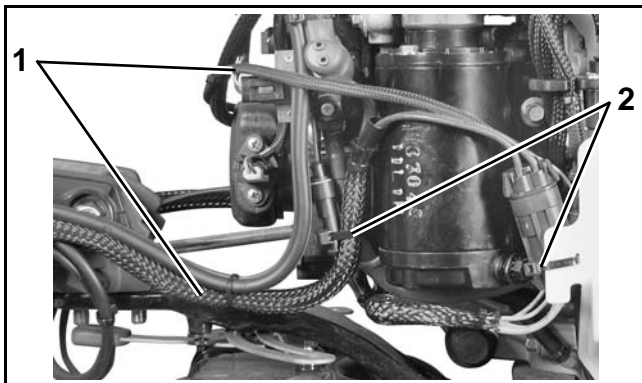

1. Wire routing  
2. Secure with straps  
007485

Install lower motor covers. Refer to **Lower Cover Installation** on p. 45.

## Control Cable Installation

Make sure throttle and shift cable ends are fully seated.

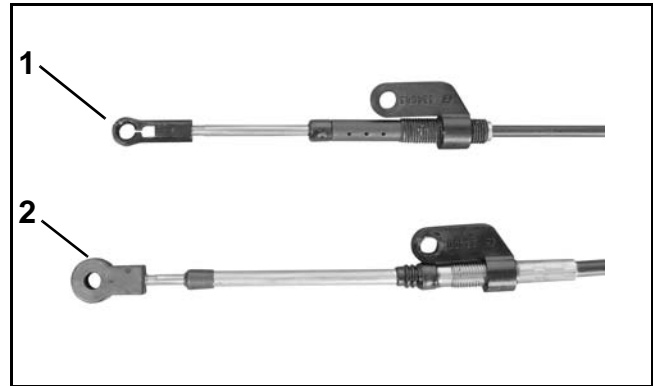

3. Throttle cable end  
4. Shift cable end  
007473

**IMPORTANT:** Do NOT use threaded cable ends to make cable adjustments.

## Shift Cable Adjustment

Secure shift cable to the shift lever pin.

For proper installation, review the following steps:

- Place washer on pin.
- Position retainer clip with straight section on the bottom and angled section on the top.
- Use long nose pliers to insert straight section of clip into linkage pin hole.

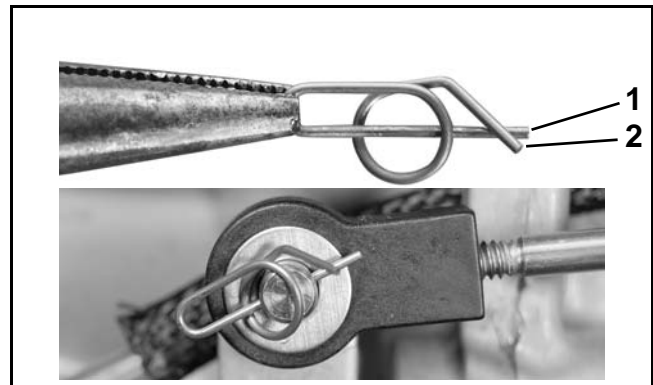

1. Straight section  
2. Angled section  
007472  
007464

- Push the clip towards the hole while lifting on the curved end with the pliers.
- Be sure retainer clip fully engages the pin.

- Lock the retainer by moving the angled section **behind** the straight section.

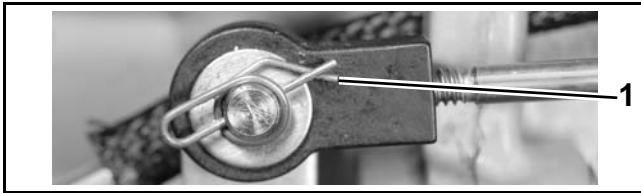

**Locked Retainer Clip** 007465  
1. Angled section behind straight section

Pull firmly on shift cable casing to remove backlash.

With outboard and shift lever in NEUTRAL, place shift cable on the trunnion bracket of intake manifold as shown. Rotate the anchor to align.

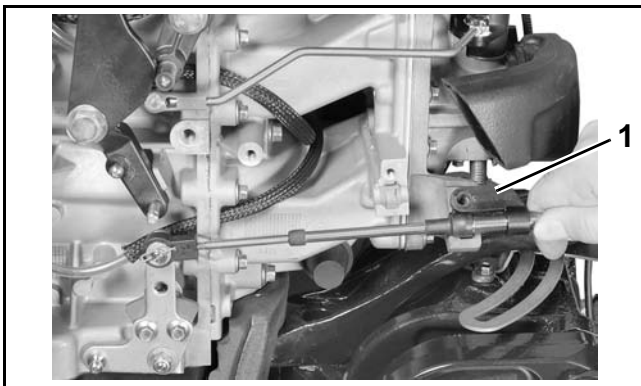

2. Anchor 007466

Install washer between anchor and trunnion bracket. Install screw. Tighten screw to a torque of 84 to 106 in. lbs. (9.5 to 12 N·m).

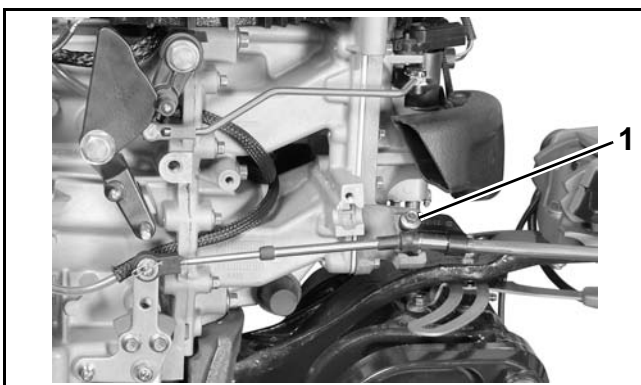

3. Screw 007467

### Throttle Cable Adjustment

Install throttle cable connector with Ball Socket Installer tool, P/N 342225.

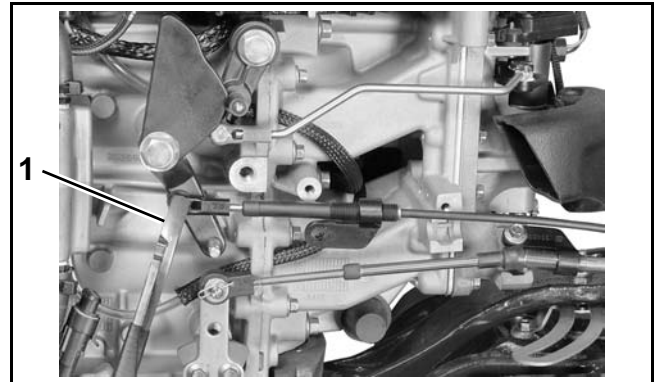

1. Installer tool, P/N 342225 007468

Place throttle cable through upper trunnion pocket.

Hold twist grip in IDLE position. Pull firmly on cable to remove backlash.

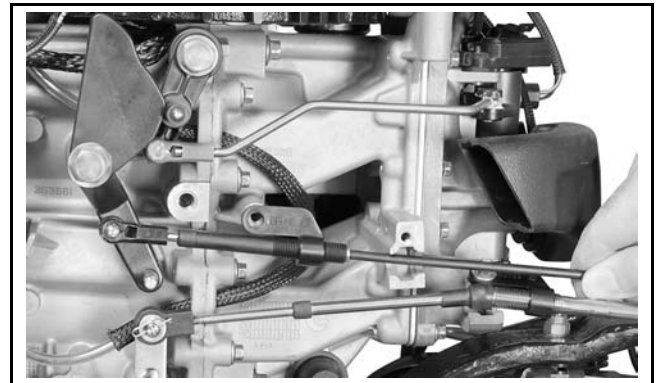

007469

## MIDSECTION TILLER HANDLE SERVICE

Adjust cable anchor so throttle cam is against IDLE stop when anchor screw hole aligns with screw boss on block.

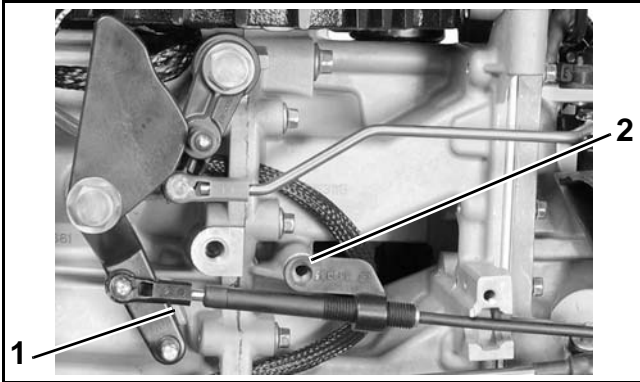

1. Idle stop
2. Anchor aligned with screw hole

007470

Install washer between anchor and boss. Install screw. Tighten screw to a torque of 84 to 106 in. lbs. (9.5 to 12 N-m).

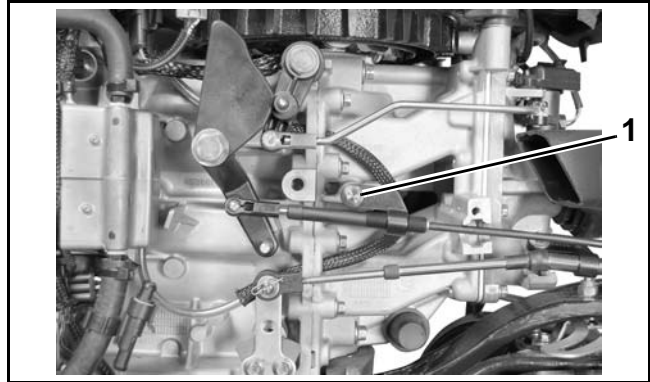

1. Cable anchor screw

007471

Rotate anchor one additional turn toward the end of the cable.

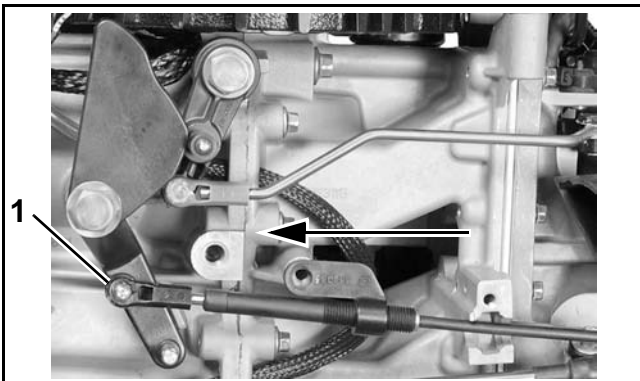

1. End of cable

007470

**IMPORTANT:** Rotate twist grip. Make sure throttle cam goes to full throttle without overloading cable, and still returns to IDLE stop.

# GEARCASE

## TABLE OF CONTENTS

SERVICE CHART .....	244
PROPELLER SERVICE .....	245
INSPECTION .....	245
PROPELLER SELECTION .....	245
PROPELLER HARDWARE INSTALLATION .....	246
GEARCASE LEAK TEST .....	247
TRIM TAB SERVICE .....	247
REMOVAL .....	247
INSTALLATION .....	247
GEARCASE REMOVAL AND INSTALLATION .....	248
GEARCASE REMOVAL .....	248
GEARCASE INSTALLATION .....	248
WATER PUMP SERVICE .....	250
DISASSEMBLY .....	250
INSPECTION .....	250
ASSEMBLY .....	250
GEARCASE DISASSEMBLY .....	253
PRE-DISASSEMBLY INSPECTION .....	253
PROPELLER SHAFT BEARING HOUSING REMOVAL .....	254
SHIFTER, GEAR AND PROPELLER SHAFT REMOVAL .....	255
BEARING AND SEAL REMOVAL .....	256
DRIVESHAFT SEALS .....	256
DRIVESHAFT BEARING .....	256
PINION BEARINGS .....	257
FORWARD BEARING .....	257
SHIFT ROD BUSHING AND O-RING .....	257
PROPELLER SHAFT BEARING HOUSING SEALS AND O-RING .....	258
BEARING AND SEAL INSTALLATION .....	258
PROPELLER SHAFT BEARING HOUSING BEARINGS .....	258
PROPELLER SHAFT BEARING HOUSING SEALS AND O-RING .....	259
SHIFT ROD BUSHING AND O-RING .....	259
FORWARD BEARING .....	259
PINION BEARINGS .....	260
DRIVESHAFT BEARING .....	260
DRIVESHAFT SEALS .....	261
GEARCASE ASSEMBLY .....	261
PROPELLER SHAFT, GEAR AND SHIFTER INSTALLATION .....	261
PROPELLER SHAFT BEARING HOUSING INSTALLATION .....	264

**GEARCASE  
SERVICE CHART**

**SERVICE CHART**

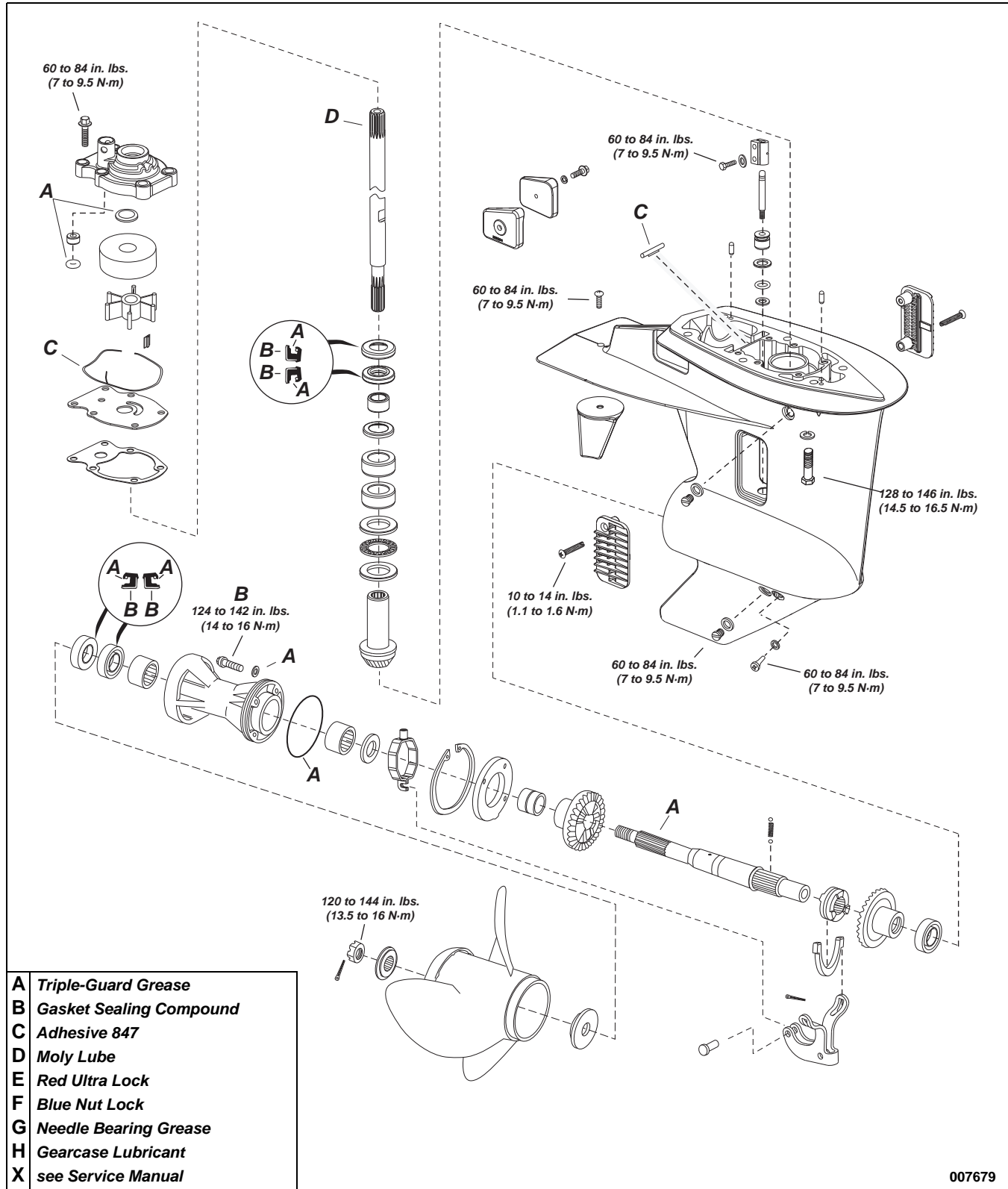

007679

# PROPELLER SERVICE

## Inspection

Carefully examine propeller and outboard for the following:

- Damaged blades and signs of propeller cavitation (burned paint, etc.)
- Spun or overheated inner hub
- Worn or twisted splines and inadequate lubricant
- Damaged or missing converging ring (if applicable)
- Damage to outer hub area
- Worn, missing, or incorrect thrust washer and spacer
- Correct size and style
- Check for bent or damaged propeller shaft and twisted splines.

Refer to **Propeller Hardware Installation** on p. 246.

### ⚠ WARNING

When servicing the propeller, always shift the outboard to **NEUTRAL**, turn the key switch **OFF**, and disconnect the battery positive (+) cable so the outboard cannot be started accidentally.

## Propeller Selection

### ⚠ CAUTION

**Selection of the wrong propeller could reduce engine service life, affect boat performance, or cause serious damage to the powerhead.**

Water testing with various propeller designs and sizes is the best method of propeller selection.

The correct propeller, under normal load conditions, will allow the engine to run near the midpoint of the RPM operating range at full throttle. Refer to **SERVICE SPECIFICATIONS** on p. 10.

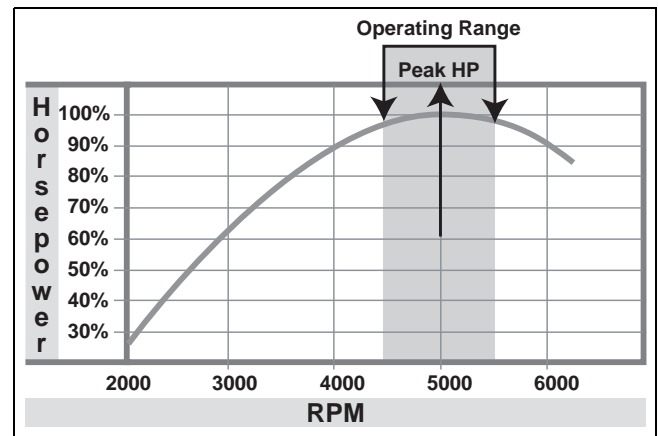

008329

**NOTICE** If the propeller blades have too much pitch, the engine will operate below its normal range at full throttle. Power will be lost, and powerhead damage could occur. If the propeller blades have too little pitch, the engine will operate above its normal range and damage from overspeeding could occur.

## GEARCASE

### PROPELLER SERVICE

When selecting a propeller, consider the following:

- Use an accurate tachometer to determine the engine's full-throttle RPM.
- The outboard should be trimmed for top speed.
- Select a propeller that suits the customer's application and allows the engine to run near the midpoint of the full-throttle operating range when the boat has a normal load.
- Occasionally, one propeller will not cover a wide range of boat applications — water skiing to high speed performance boating. In such cases, it might be necessary to have a propeller for each situation.
- Refer to the *Evinrude/Johnson Genuine Parts and Accessories Catalog* for propeller styles and sizes.

## Propeller Hardware Installation

### WARNING

To prevent accidental starting while servicing, twist and remove all spark plug leads.

**IMPORTANT:** Depending on propeller style, different thrust bushings, spacers, and cotter pin keepers are used. See the *Evinrude/Johnson Genuine Parts and Accessories Catalog* for correct propeller hardware.

Apply *Triple-Guard* grease to the entire propeller shaft before installing the propeller.

Install thrust bushing onto propeller shaft with taper of bushing matching taper of shaft.

Align splines of propeller and shaft. Push propeller until seated on the thrust bushing.

Install the spacer over the propeller shaft splines.

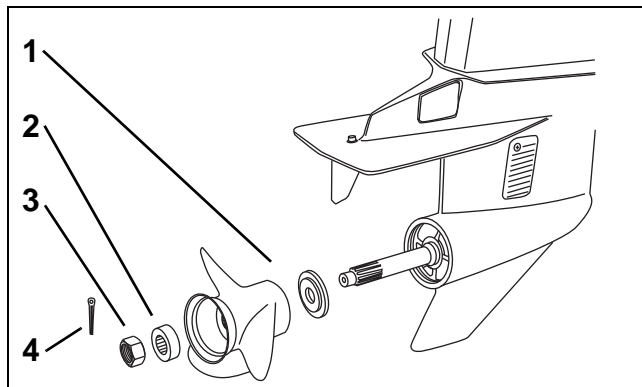

1. Thrust bushing
2. Spacer
3. Propeller Nut
4. Cotter pin

007055

Wedge a block of wood between propeller blade and the anti-ventilation plate.

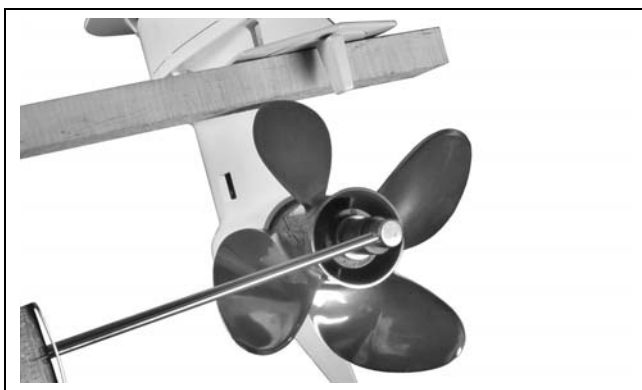

001992

Install the propeller nut and tighten to a torque of:

- 120 to 144 in. lbs. (13.5 to 16.5 N·m)

If cotter pin holes in the nut and shaft do not align, tighten further. Do not loosen.

Install new cotter pin.

**IMPORTANT:** After installation, make sure outboard is in NEUTRAL and carefully spin propeller. Propeller must turn freely and should not spin off center. If propeller appears to wobble, check for possible bent propeller shaft.



## GEARCASE LEAK TEST

Drain lubricant before testing.

Use Gearcase Pressure Tester, P/N 507977. Install lubricant drain/fill plug and seal, thread pressure test gauge fitting and seal in lubricant level hole.

Pressurize 3 to 6 psi (21 to 42 kPa).

If pressure gauge indicates leakage, submerge the gearcase in water to determine source of leak.

If the gauge does not indicate leakage, increase pressure to 16 to 18 psi (110 to 124 kPa). Check for leaks.

Make necessary repairs and repeat test.

Install Gearcase Vacuum Tester, P/N 507982. Apply 3 to 5 in. of vacuum (76 to 127 mm) Hg. with pump.

If vacuum gauge indicates leakage, apply oil around suspected seal. If leak stops or oil is drawn in, seal is defective.

Repeat test, gearcase must hold minimum of 15 in. vacuum (381 mm) Hg.

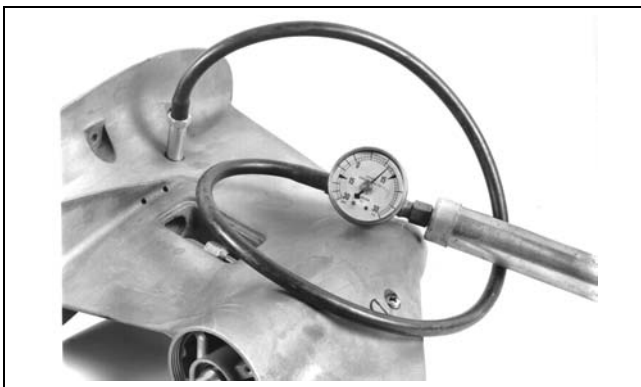

38640

## TRIM TAB SERVICE

### Removal

Note where the index mark on the gearcase aligns with the index mark of the adjustable trim tab so the trim tab can be installed in the same position.

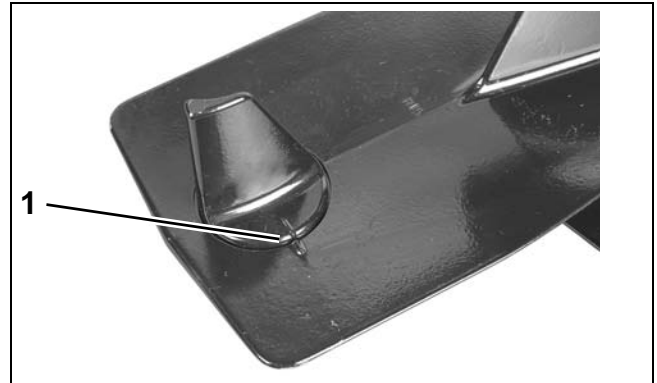

1. Index marks

007651

Remove the trim tab retaining screw and trim tab from the gearcase.

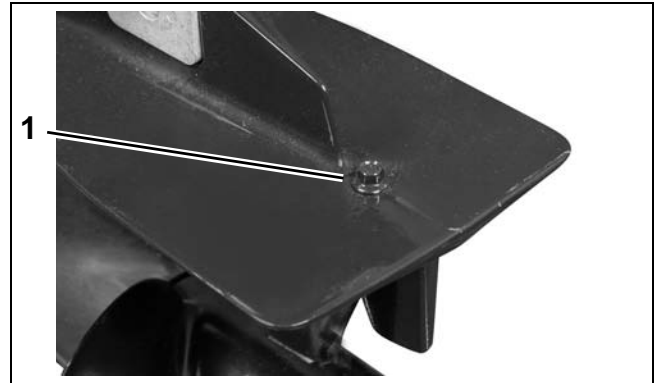

1. Trim tab retaining screw

007652

### Installation

Apply *Gasket Sealing Compound* to threads of the trim tab screw. Install and align the trim tab with the index marks noted prior to disassembly. Tighten the trim tab screw to a torque of 60 to 84 ft. lbs. (7 to 9.5 N·m). For adjustment, refer to **Trim Tab Adjustment** on p. 27.

# GEARCASE REMOVAL AND INSTALLATION

## Gearcase Removal

**⚠ WARNING**

To prevent accidental starting while servicing, twist and remove all spark plug leads.

During service, the outboard may drop unexpectedly. Avoid personal injury; always support the outboard's weight with a suitable hoist or the tilt support bracket during service.

Remove water intake screens.

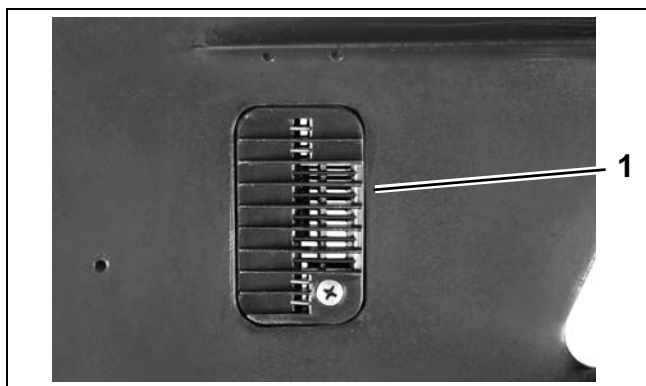

1. Water intake screen 007649

Remove the upper shift rod connector screw.

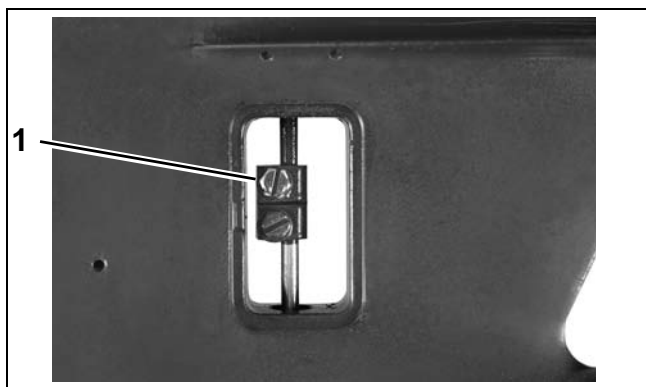

1. Shift rod connector screw 007650

Remove the six gearcase retaining screws or nuts (25 inch models).

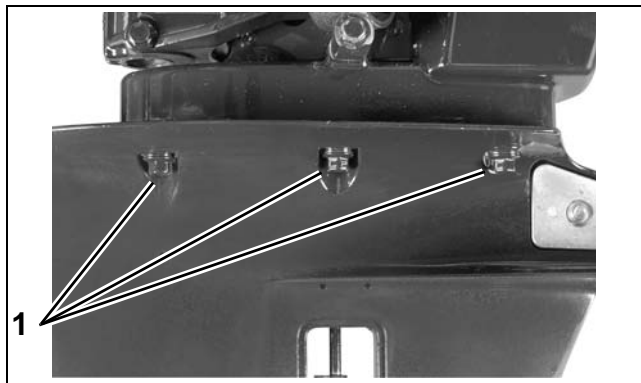

1. Gearcase retaining screws 007653

Remove the gearcase assembly from the exhaust housing, being careful not to bend the shift rod.

## Gearcase Installation

**⚠ WARNING**

During service, the outboard may drop unexpectedly. Avoid personal injury; always support the outboard's weight with a suitable hoist or the tilt support bracket during service.

Coat the driveshaft splines with *Moly Lube*. DO NOT coat top surface of the driveshaft because lubricant may prevent seating of the driveshaft in the crankshaft.

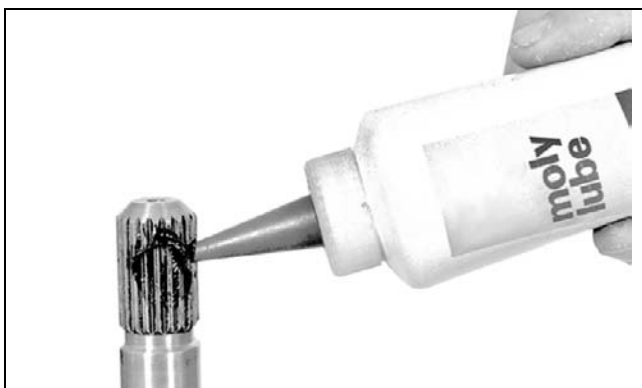

30385

**GEARCASE REMOVAL AND INSTALLATION**

Slide the gearcase into place, making sure that:

- Driveshaft engages the crankshaft
- Water tube enters grommet on water pump
- Upper shift rod enters the shift rod connector.

Apply *Gasket Sealing Compound* to threads of the gearcase retaining screws. Install and tighten the screws to a torque of 128 to 146 in. lbs. (14.5 to 16.5 N·m).

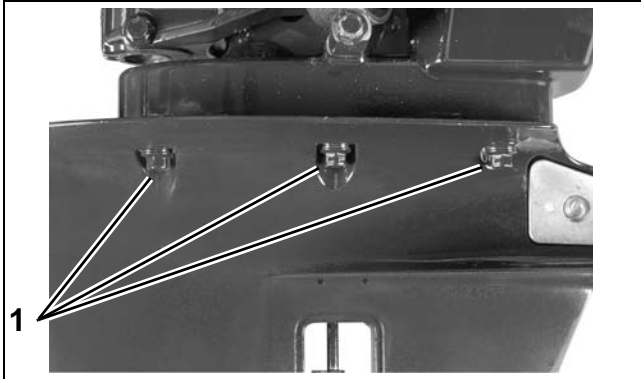

1. Gearcase retaining screws

007653

For 25 inch models, apply *Triple-Guard* grease to threads of the studs. Install washers and gearcase retaining nuts. Tighten nuts to a torque of 128 to 146 in. lbs. (14.5 to 16.5 N·m).

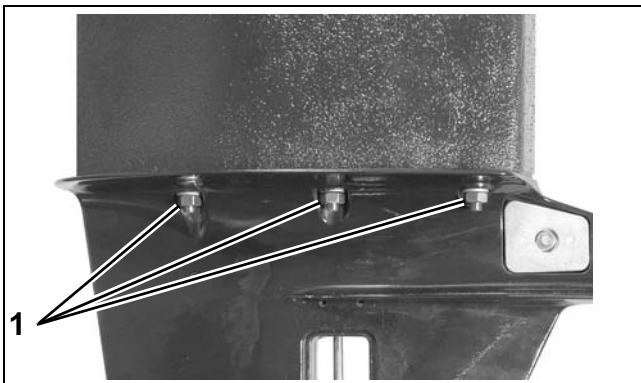

1. Gearcase retaining nuts

008371

Align the groove in the upper shift rod with the screw hole in the connector. Apply *Gasket Sealing Compound* to threads of the shift rod connector

screw. Tighten screw, with washer, to a torque of 60 to 84 in. lbs. (7 to 9.5 N·m).

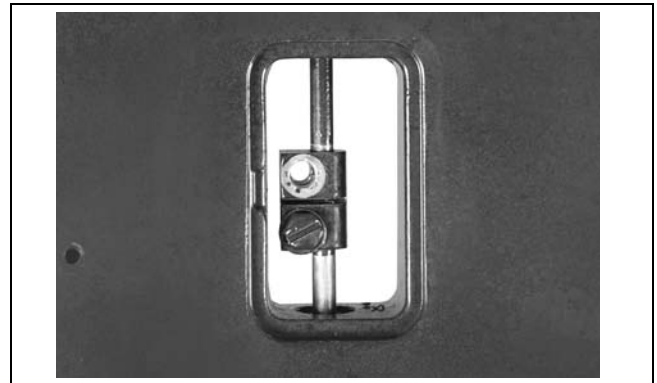

007654

Install the port and starboard water intake screens with water intake holes positioned at the rear of gearcase. Tighten screws to a torque of 10 to 14 in. lbs. (1.1 to 1.6 N·m).

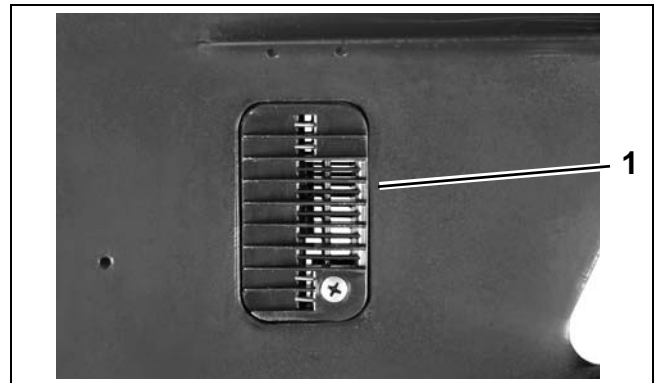

1. Water intake screen

007649

**⚠ WARNING**

To prevent loss of operator control, check for proper shifting operation and adjust, if necessary.

**IMPORTANT:** During break-in period of a reassembled gearcase, change the gearcase lubricant between 10 to 20 hours of operation.

# WATER PUMP SERVICE

## Disassembly

Remove the impeller housing screws.

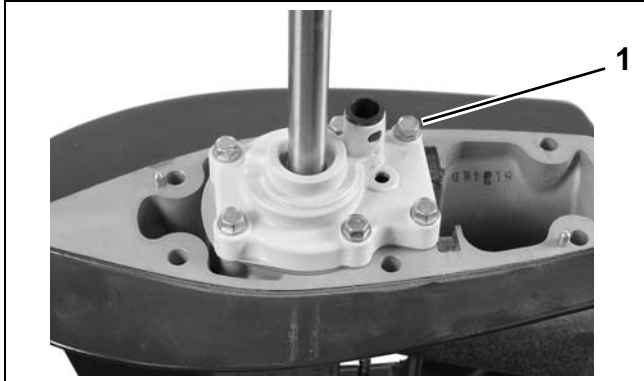

1. Screws 007655

Pull up on the driveshaft and remove the driveshaft with the water pump assembly from the gearcase. Remove the water pump assembly from the driveshaft.

Remove the impeller plate and gasket. Discard the gasket.

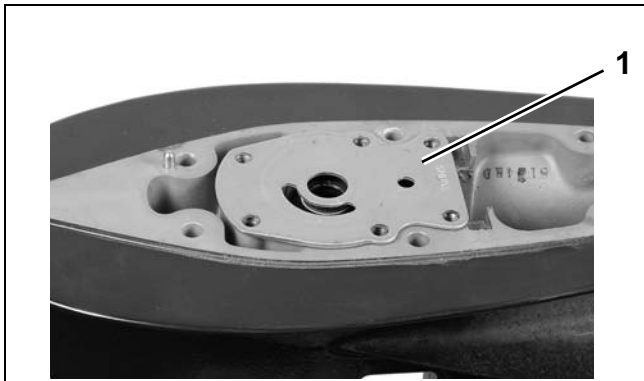

1. Impeller plate 007656

Remove the water pump grommet, all O-rings, and the shift rod bushing from the impeller housing.

## Inspection

Check impeller for overheating, hub separation, and other wear or damage.

Check liner and wear plate for scoring, distortion, and impeller material transfer.

Inspect the housing for cracks or melting.

Make sure gasket surface is clean and smooth.

## Assembly

Oil and install the shift rod bushing into the impeller housing.

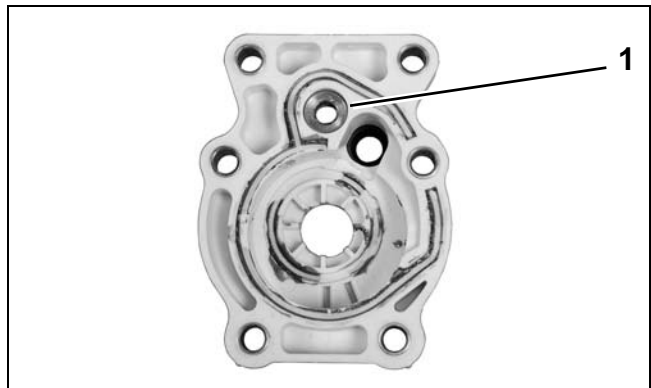

1. Shift rod bushing 007657

Apply *Triple-Guard* grease to the shift rod O-ring and install below bushing.

Apply a thin bead of *Adhesive 847* in the inner groove of the impeller housing and install a new impeller cup O-ring.

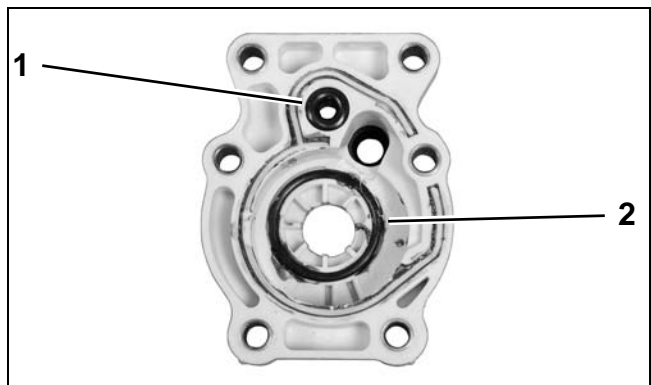

1. Shift rod O-ring  
2. Impeller cup O-ring 007658

Lightly coat the exterior of the impeller cup with *Gasket Sealing Compound*. Align tabs of impeller cup with location holes of impeller housing and install the impeller cup into the impeller housing.

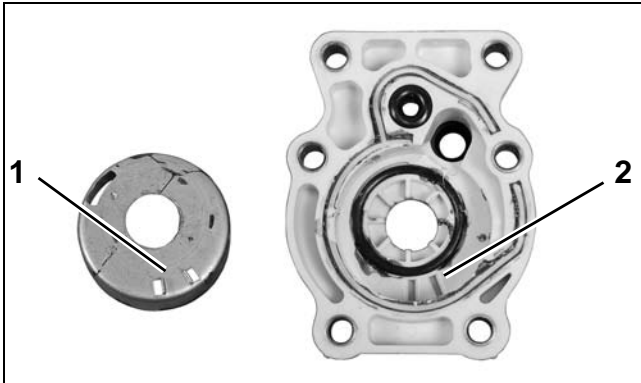

1. Tabs, impeller cup  
2. Location holes  
007659

Lightly coat the inside of the impeller cup with oil. With a counterclockwise rotation, install the impeller into the impeller cup.

**IMPORTANT:** The sharp edge of key slot in the impeller is the leading edge during rotation.

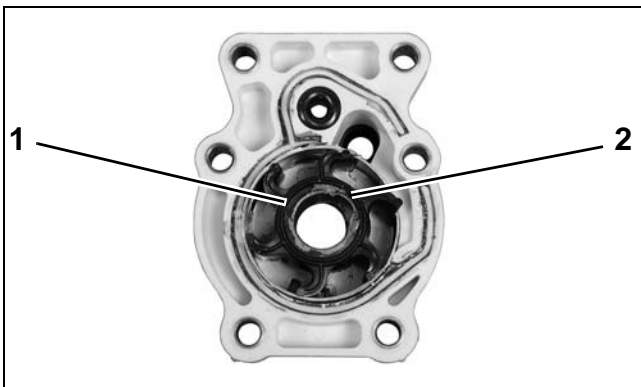

1. Impeller  
2. Sharp edge  
007660

Apply *Adhesive 847* to the outer seal groove of the impeller housing. Install a new seal into the groove.



1. Seal  
007661

Lightly oil pinion splines of the driveshaft. Slide the driveshaft through the impeller housing and impeller until drive key flat of the driveshaft is below the impeller. Align drive key flat with groove of the impeller. Install the impeller drive key.



1. Drive key  
007662

## GEARCASE WATER PUMP SERVICE

Sharp edge of the key is leading edge during driveshaft rotation. Slide the impeller housing down the driveshaft. Engage the impeller with the key.

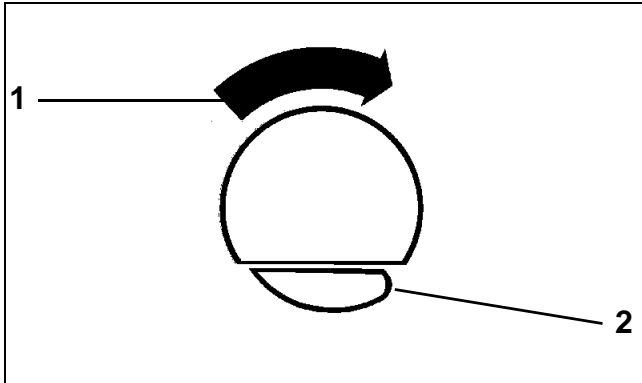

1. Driveshaft rotation
2. Drive key

CO2995

Turn the driveshaft until holes of the impeller housing are aligned with holes of the gearcase. Apply *Gasket Sealing Compound* to threads of the impeller housing screws. Tighten the screws to a torque of 60 to 84 in. lbs. (7 to 9.5 N·m).



007663

**NOTICE** Make sure the impeller engages the impeller key. Serious powerhead damage will result if impeller key is not in place.

Lightly coat both sides of a new impeller plate gasket with *Gasket Sealing Compound*. Place gasket on the gearcase.

Place the impeller plate over the gasket.

Slide the driveshaft down into the gearcase and engage the pinion.

Apply *Adhesive 847* to outside of water tube grommet. Install grommet and locate grommet bosses into holes of impeller housing.

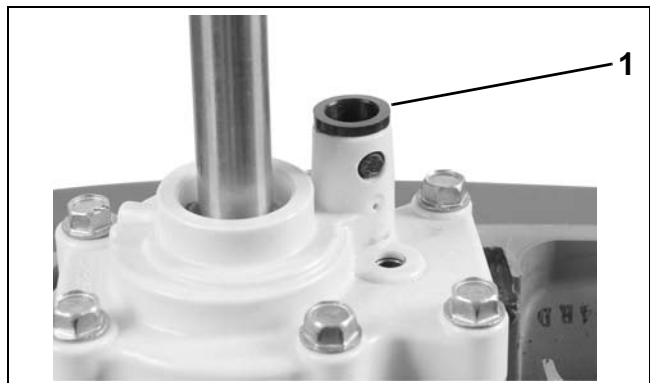

1. Grommet

007664

# GEARCASE DISASSEMBLY

## Pre-Disassembly Inspection

**⚠ WARNING**

Wear safety glasses to avoid personal injury, and set compressed air pressure to less than 25 psi (172 kPa).

**IMPORTANT:** Clean and inspect all parts during disassembly. Replace any damaged parts, seals, O-rings, and gaskets.

Remove the propeller and mounting hardware.

Drain and inspect oil as described in **Gearcase Lubricant** on p. 34.

Remove gearcase. Refer to **GEARCASE REMOVAL AND INSTALLATION** on p. 248.

Remove water pump. Refer to **WATER PUMP SERVICE** on p. 250.

Before disassembling the gearcase, examine the following:

- **Gearcase Housing** — Check for visible damage to skag, strut, anti-ventilation plate, bullet, and mating surface. Check seal areas for visible signs of lubricant leakage.
- **Propeller Shaft** — Check for bent or damaged shaft. Check for twisted splines and damaged threads.
- **Shift Rod** — Check for bent, or binding rod.

- **Hydrostatic Seal Grooves** — Must be in good condition to help prevent propeller ventilation.

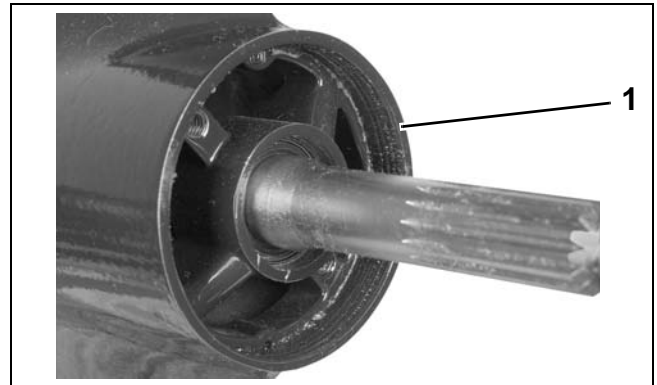

1. Hydrostatic seal grooves

007665

- **Gearcase Anodes** — If anodes have eroded to two-thirds their original size, they must be replaced.

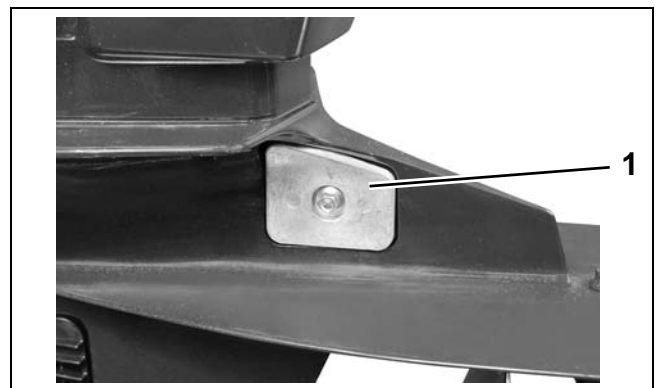

1. Gearcase anode

007666

- **Drive Shaft** — Check splines for visible damage, twisting and wear. Severe spline wear indicates the exhaust housing or gearcase has been distorted, possibly by impact damage.

Remove and discard exhaust seal assembly.

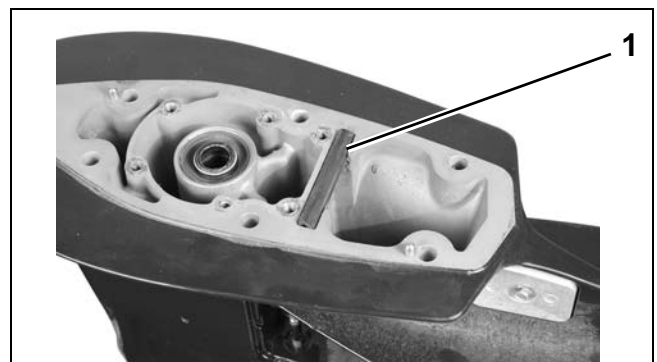

1. Seal assembly

007667

## GEARCASE GEARCASE DISASSEMBLY

### Propeller Shaft Bearing Housing Removal

Remove the two propeller shaft bearing housing screws.



1. Screws 007668

Remove the propeller shaft bearing housing from the gearcase using the Universal Puller Set, P/N 378103:

- Puller body, P/N 307636
- Handle, P/N 307638
- Pressing screw, P/N 307637
- Two flat washers, P/N 307639
- Two 1/4-20 x 6 in. screws (obtain locally)

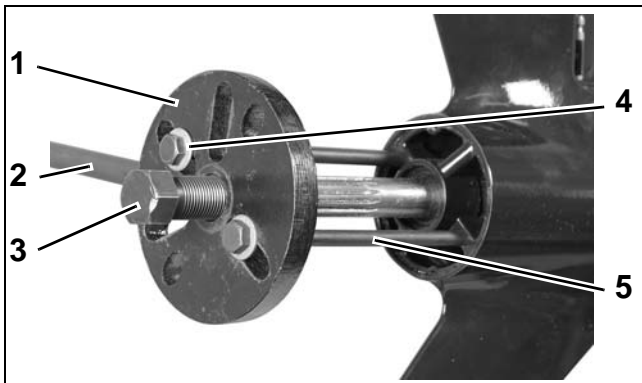

1. Body  
2. Handle  
3. Pressing screw  
4. Washers  
5. Screws (obtain locally) 007669

Remove the retaining ring using Retaining Ring Pliers, P/N 331045.

#### CAUTION

Retaining ring is under extreme pressure during removal and installation. To prevent personal injury, wear safety glasses and proceed with care to avoid unsnapping the ring from the pliers. After the retaining ring is removed far enough from the gearcase to clear the housing, release the tension on the pliers while retaining ring is still around the propeller shaft.

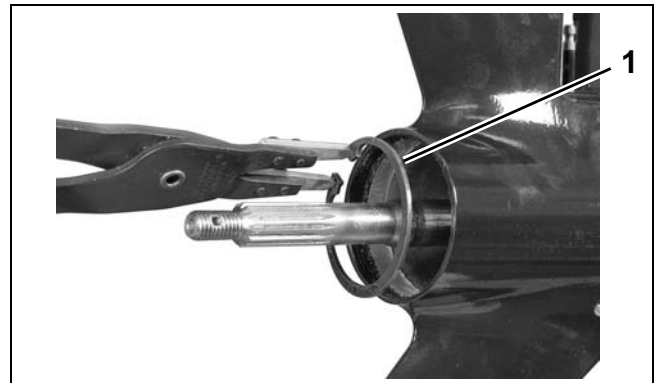

1. Retaining ring 007670

Remove the retainer plate from the gearcase.

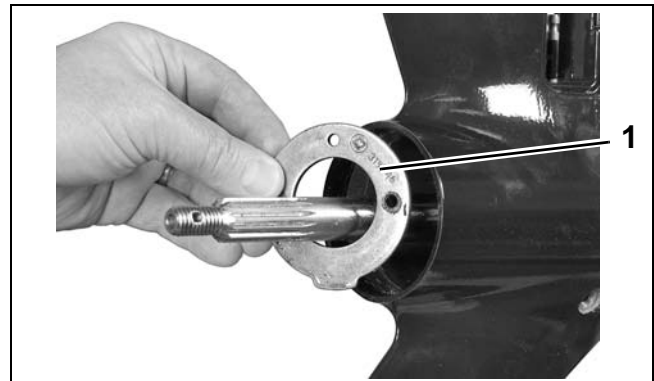

1. Retainer plate 007671



## Shifter, Gear and Propeller Shaft Removal

Unscrew the lower shift rod from the shifter yoke and remove the shift rod from the gearcase.



1. Lower shift rod

007672

Use long-nose pliers to remove the shift yoke.

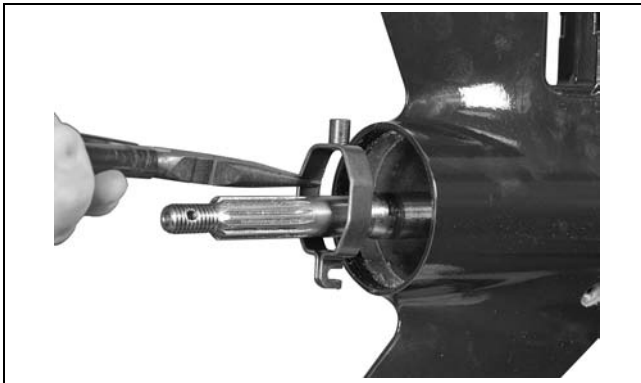

007673

Remove the shifter lever pivot pin. Discard the pivot pin O-ring.

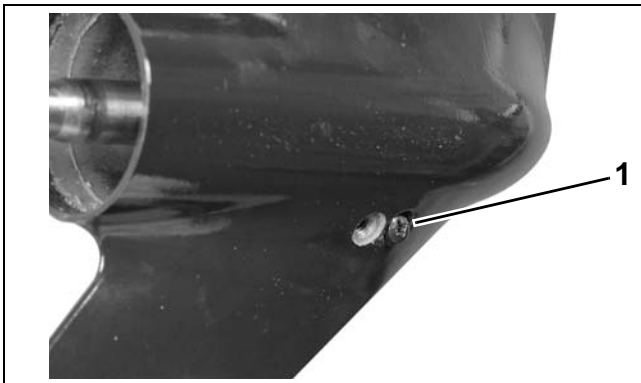

1. Shift lever pivot pin

007674

Remove the propeller shaft and reverse gear components from the gearcase.

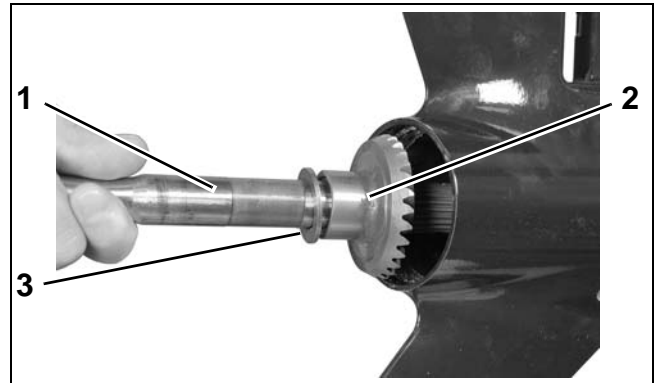

- 1. Propeller shaft
- 2. Reverse gear
- 3. Thrust washer

007675

**IMPORTANT:** Shifter detent balls and spring will pop out of the clutch when the propeller shaft is removed.

Use a magnet to locate and remove the two shifter detent balls and one detent spring from the gearcase.

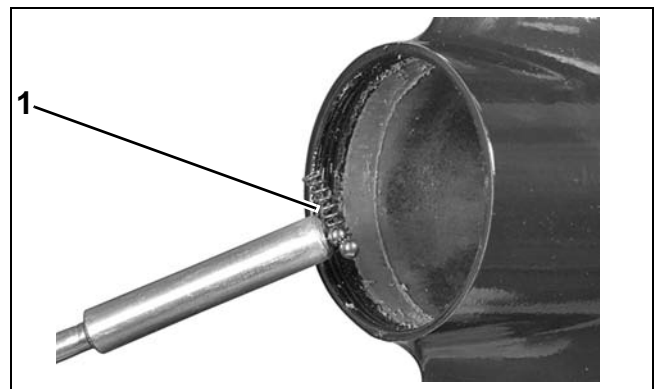

1. Spring and balls

007676

## GEARCASE

### BEARING AND SEAL REMOVAL

Use long-nose pliers to remove the clutch and shifter lever assembly. Use no force. Tilting the shifter lever slightly will allow you to remove it from the gearcase.

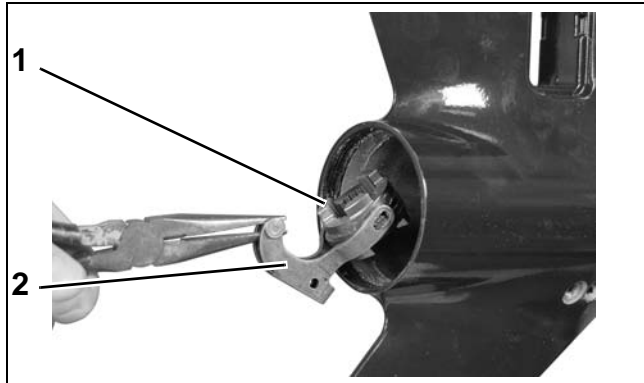

1. Clutch
2. Shifter lever assembly

007677

Remove the forward bearing, forward gear, pinion, pinion thrust bearing, and two pinion thrust washers.

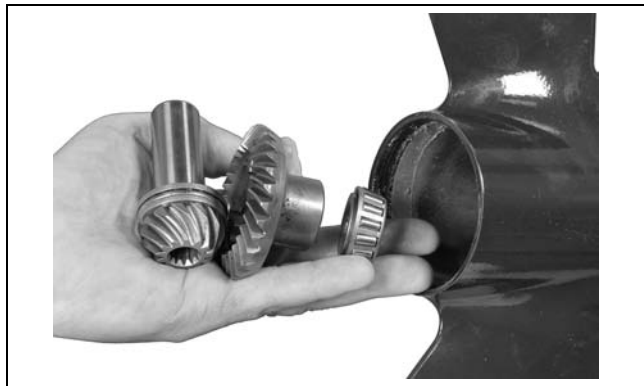

007678

## BEARING AND SEAL REMOVAL

**IMPORTANT:** Inspect bearings for damage while in place. If bearing is damaged, remove and discard. If the bearing is removed for any reason, it must be replaced.

### Driveshaft Seals

Use Puller Bridge, P/N 432127, and Small Puller Jaws, P/N 432131, to remove the two driveshaft seals. Discard the seals.

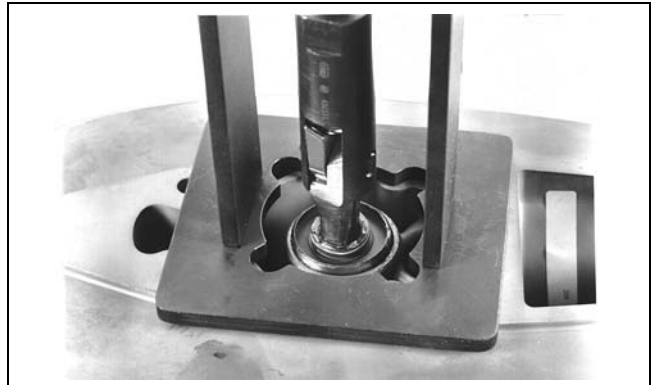

38633

### Driveshaft Bearing

Use Puller Bridge, P/N 432127, and Small Puller Jaws, P/N 432131 to remove the driveshaft bearing and sleeve from the gearcase. Discard the bearing.

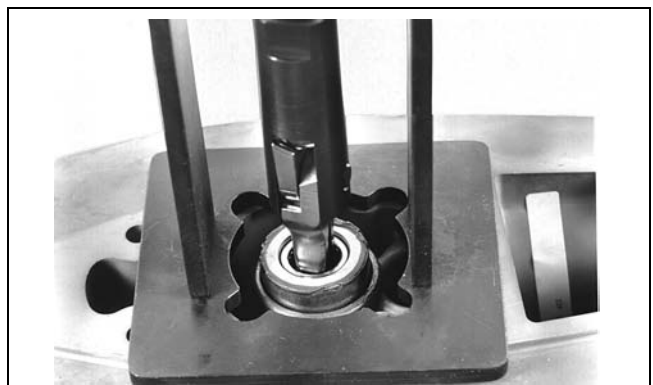

38634

## Pinion Bearings

Assemble the following components from Universal Pinion Bearing Remover and Installer, P/N 5005927.

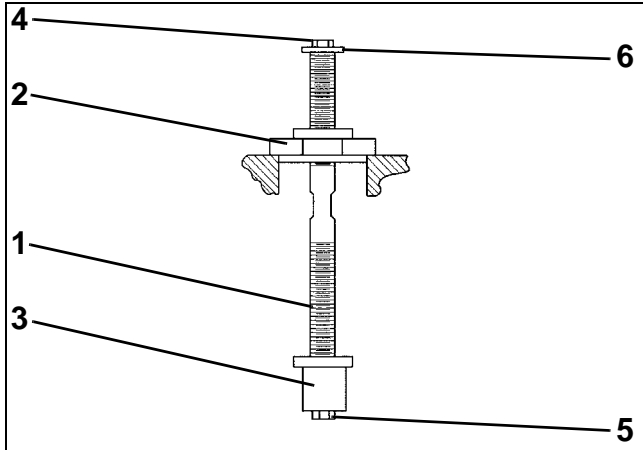

1. Rod, P/N 326582
2. Pilot Plate, P/N 326583
3. Remover and Installer, P/N 326577
4. 1/4-20 x 1/2 in. hex head screw
5. 1/4-20 x 11/4 in. hex head screw
6. 1 in. O.D. flat washer

CO3125

Place the tool in gearcase. using a mallet, drive the pinion bearings into the gearcase propeller shaft cavity. Discard the bearings.

## Forward Bearing

Use Slide Hammer, P/N 432128, and Bearing Puller, P/N 432130, to remove the forward bearing cup from the gearcase.

Secure the puller jaws into grooves behind the cup. Use Wrench, P/N 334359, to hold the puller while tightening the jaws.

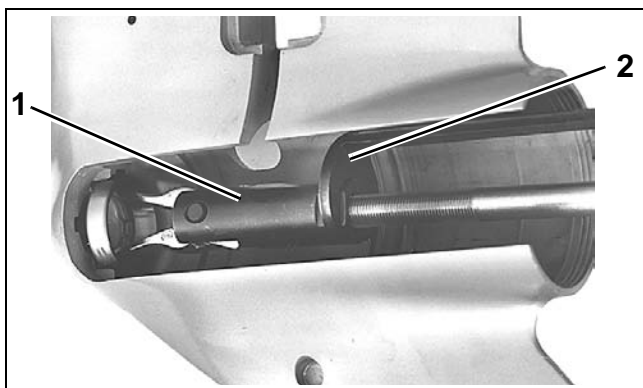

1. Bearing puller
2. Wrench

21789

## Shift Rod Bushing and O-ring

Position Shift Rod Bushing Remover, P/N 327693, under the shift rod bushing.

Thread the adapter of the Slide Hammer, P/N 391008, in the slide hammer. Place the adapter through the shift rod bushing and thread into the remover tool.

Remove the handle from the remover tool. Then remove the bushing from the gearcase.

Once the bushing has been removed from the gearcase, examine the bushing for damage. If damaged, replace the bushing on reassembly. Remove and discard the O-ring(s) and washer from the bushing.

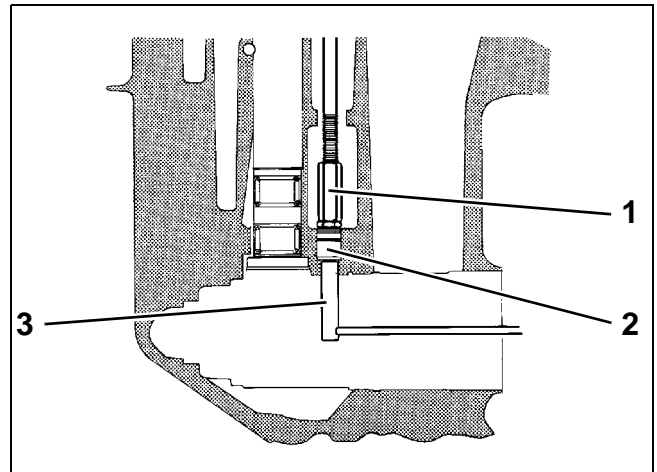

1. Adapter
2. Shift rod bushing
3. Remover tool, P/N 327693

DRC1505

## GEARCASE BEARING AND SEAL INSTALLATION

### Propeller Shaft Bearing Housing Seals and O-ring

Remove and discard the propeller shaft bearing housing O-ring.



1. O-ring 007680

Use Puller Bridge, P/N 432127, and Small Puller Jaws, P/N 432131, to remove seals. Discard seals.



1. Small puller jaws 32555

Use Puller Bridge, P/N 432127, and Small Puller Jaws, P/N 432131, to remove both propellers shaft bearings from the bearing housing. Discard both bearings.



1. Small puller 21795

### BEARING AND SEAL INSTALLATION

**IMPORTANT:** Make no dry assemblies. Lubricate all bearings, shafts, and gears with gearcase lubricant.

Press the bearings into the housings until the tools are seated on the housing.

### Propeller Shaft Bearing Housing Bearings

Use Bearing Installer, P/N 335820, to install a new bearing in the rear end of bearing housing. Position installer against the lettered side of bearing. Press the bearing into the housing until the tool is seated on the housing.



21793

Use Bearing Installer, P/N 321428, to install a new bearing in the forward end of the bearing housing. Position installer against the lettered side of bearing.



21794

## Propeller Shaft Bearing Housing Seals and O-ring

Install new seals back to back in aft end of the propeller shaft bearing housing using Seal Installer, P/N 335821. Apply *Gasket Sealing Compound* to the metal casing of the seals before installing. Install the inner seal with lip facing into the bearing housing and install the outer seal with lip facing away from the bearing housing. Apply *Triple-Guard* grease to seal lips after installing.

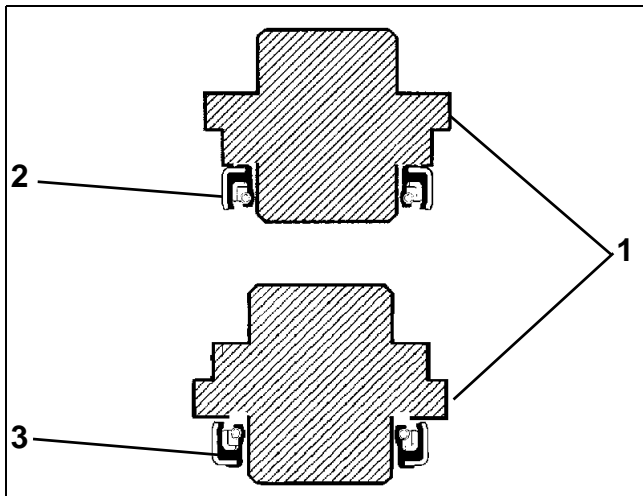

1. Seal installer
2. Inner seal
3. Outer seal

DR2061  
DR2062

Apply *Triple-Guard* grease to a new bearing housing O-ring. Place the O-ring in the bearing housing groove.



1. O-ring

007680

## Shift Rod Bushing and O-ring

Coat the shift rod O-ring with *Triple-Guard* grease and install in shift rod bushing.

Place a new washer and bushing on Shift Rod Bushing Installer, P/N 304515. Apply *Gasket Sealing Compound* to the outside diameter of the shift rod bushing.

Install new bushing O-ring in outer groove of bushing.

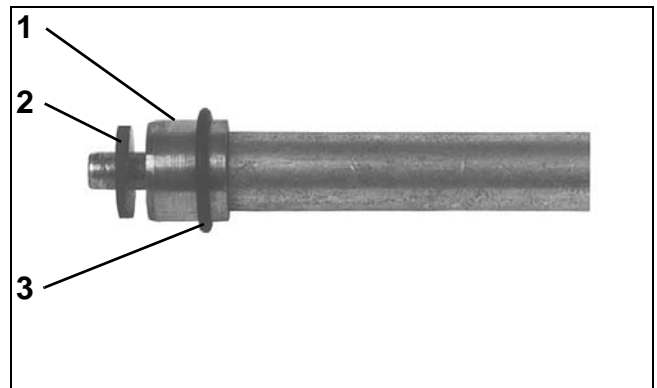

1. Bushing
2. Washer
3. O-ring, outer groove

COA3319

Use a mallet to drive the bushing into the gearcase housing.

## Forward Bearing

Place the nose of the gearcase on a wooden block on the floor. Use Drive Handle, P/N 311880, Bearing Cup Installer, P/N 319929, and a mallet to drive the bearing cup into position in the gearcase housing. Oil the forward bearing cup and seat it firmly in the housing.

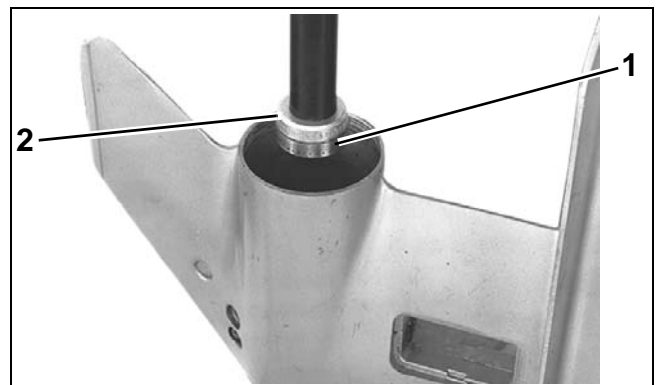

1. Forward bearing cup
2. Bearing cup installer

21791

## GEARCASE

### BEARING AND SEAL INSTALLATION

#### Pinion Bearings

Install the pinion bearings using the following components of the Universal Pinion Bearing Remover and Installer, P/N 5005927, and two tool spacers.

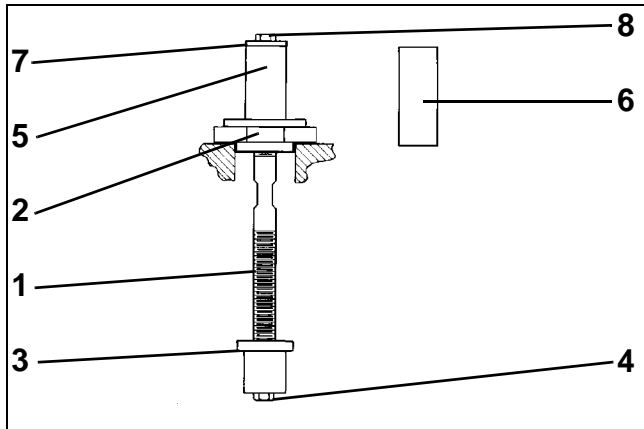

1. Rod, P/N 326582
2. Plate, P/N 326583
3. Remover/Installer, P/N 326577
4. 1/4-20 x 1 1/4 in. screw
5. Spacer, Short, P/N 330067
6. Spacer, Long, P/N 330068
7. 1 in. flat washer
8. 1/4-20 x 1/2 in. screw

DR4692

**IMPORTANT:** To ensure accurate bearing location, washer must be flat and screw must be tight.

Install **lower** pinion bearing. Assemble tool using **short** spacer, P/N 330067, and remover/installer, P/N 326577. Position installer against the lettered side of bearing. Drive bearing into gearcase housing until washer contacts spacer.

Install **upper** pinion bearing. Assemble tool using **long** spacer, P/N 330068.

#### Driveshaft Bearing

Oil and install a new driveshaft bearing in the bearing sleeve using Bearing Installer, P/N 322923. Press against the lettered side of the bearing until the tool is seated in the bearing sleeve.



1. Driveshaft bearing
2. Bearing sleeve
3. Bearing installer

21887

Use the same tool, attached to Plate, P/N 318122, to press the bearing sleeve assembly into the gearcase until the plate contacts the gearcase. Position the lettered side of the bearing against the tool.

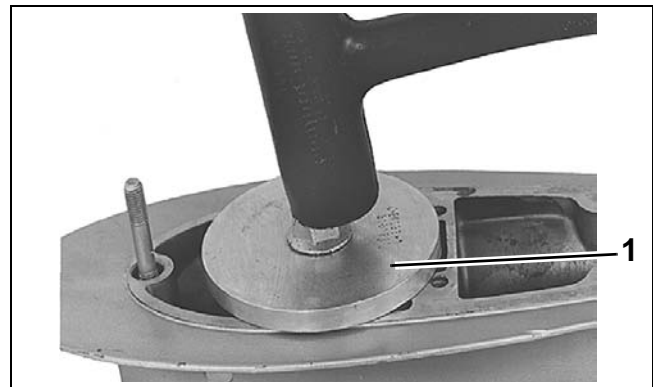

1. Plate

21813

## Driveshaft Seals

Apply *Gasket Sealing Compound* to the metal casing of the seals before installing.

Use Seal Installer, P/N 326552, to install the inner seal with flush lip facing into the gearcase, then the outer seal with extended lip facing out of the gearcase.

Apply *Triple-Guard* grease to the seal lips after installing.

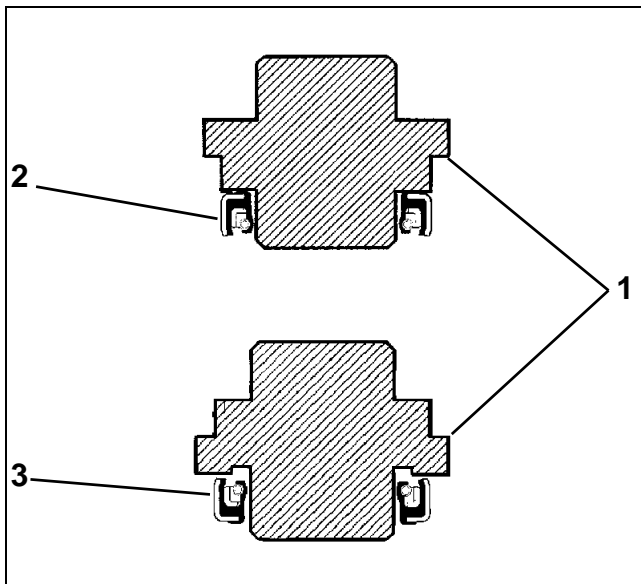

1. Seal Installer, P/N 326552
2. Inner seal
3. Outer seal

DR2061  
DR2062

## GEARCASE ASSEMBLY

### Propeller Shaft, Gear and Shifter Installation

**IMPORTANT:** Make no dry assemblies. Lubricate all bearings, shafts, and gears with gearcase lubricant.

Oil and place the forward bearing cone and roller assembly in the forward bearing cup.

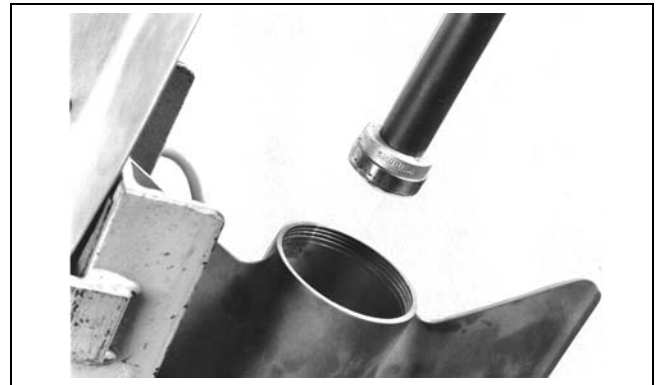

38635

Install the small thrust washer with the chamfered inside diameter facing the pinion gear. Oil and install the thrust bearing. Install the large thrust washer with chamfered outside edge facing up.

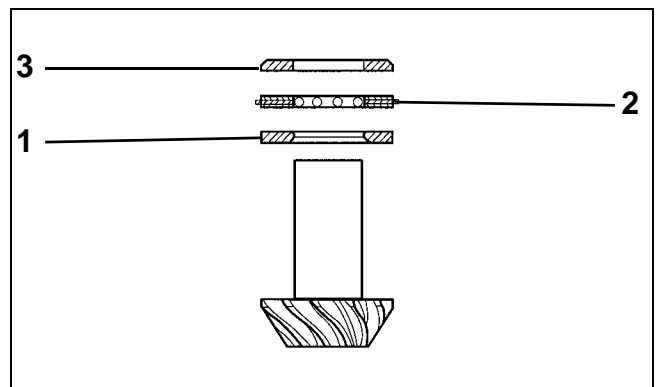

1. Small thrust washer, chamfered inside diameter
2. Thrust bearing
3. Large thrust washer, chamfered outside edge

803051

## GEARCASE GEARCASE ASSEMBLY

Use a right angled rod to install the pinion assembly in the gearcase.



COA3290

Install the shifter cradle and clutch dog in the gearcase using long-nose pliers.



38637

Place the forward gear into the gearcase.

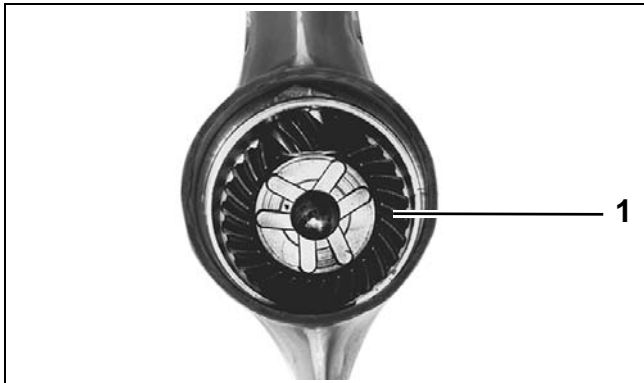

1. Forward gear

COB3057

Apply *Triple-Guard* grease to a new pivot pin O-ring. Install O-ring on the pivot pin. Apply *Nut Lock* to threads of the pin. Align hole of shifter lever with hole in gearcase. Install and tighten pivot pin to a torque of 60 to 84 in. lbs. (7 to 9.5 N·m).



1. Pivot pin

COA3236

Install the shifter cradle on clutch dog. Grooved end of clutch dog must face forward gear end of the propeller shaft.

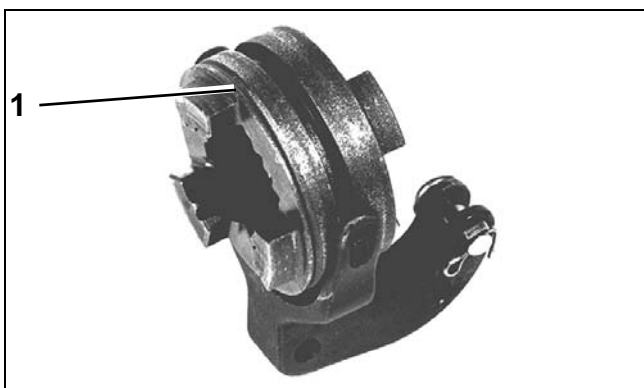

1. Grooved end

COB3065

**IMPORTANT:** Apply *Needle Bearing* grease to clutch dog and shifter cradle to hold in place while assembling.

### **WARNING**

**Wear safety glasses for eye protection.  
Detent balls can pop out with great force.**



Slide the Shift Detent Sleeve, P/N 328081, over the propeller shaft. Align slot in the tool with hole in the propeller shaft.

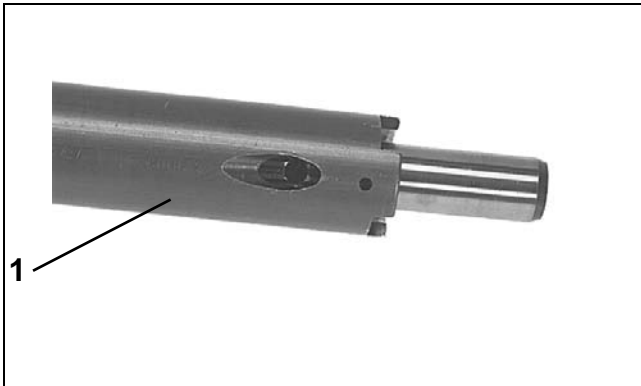

1. Shift detent sleeve

26727

Insert one detent ball, then the spring, then the other detent ball. Push down on the ball and slide the tool back until you feel the ball slip into the detent.

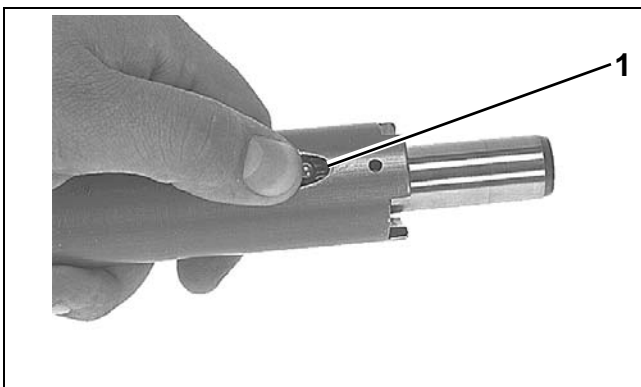

1. Detent ball

26728

Install the propeller shaft and detent tool in gearcase. Make sure the following occurs:

- Propeller shaft must engage forward bearing.
- Tool ramps must engage clutch dog ramps.
- Hold tool firmly against clutch dog.

- Gently tap propeller shaft with a rawhide mallet to seat detent assembly.

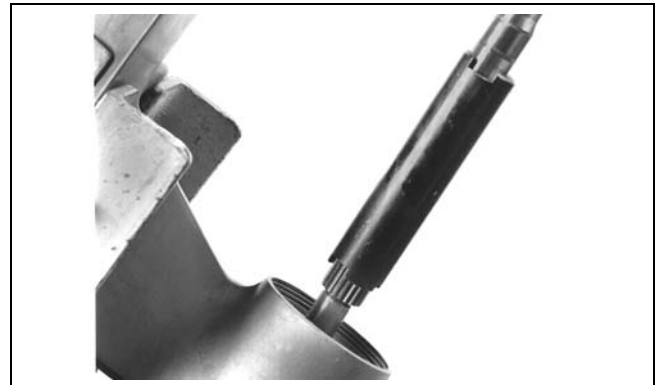

38638

Remove detent tool. Slide the reverse gear down the propeller shaft and into the gearcase.

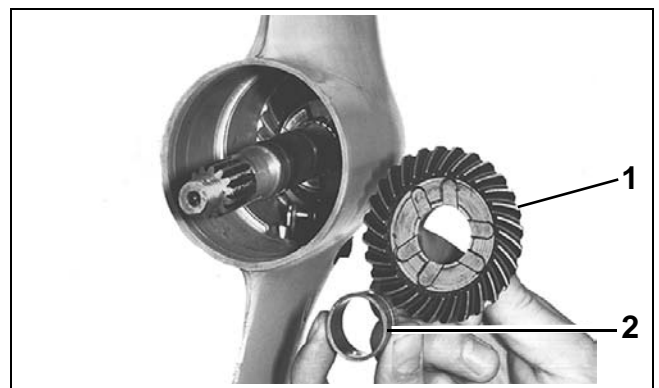

1. Reverse gear  
2. Bushing

COB3051

Coat the reverse gear bushing with oil. Slide the bushing down the propeller shaft, seating the bushing into the reverse gear.

## GEARCASE GEARCASE ASSEMBLY

Holding the shifter yoke with long-nose pliers, install the yoke at a tilted position, locating top of yoke into upper gearcase cavity.

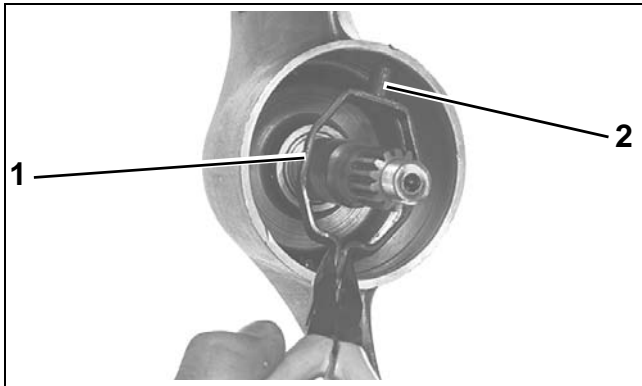

1. Shifter yoke
2. Top of yoke

COA3229

Engage the shifter yoke hook onto the shifting lever clevis pin in bottom of the gearcase cavity.

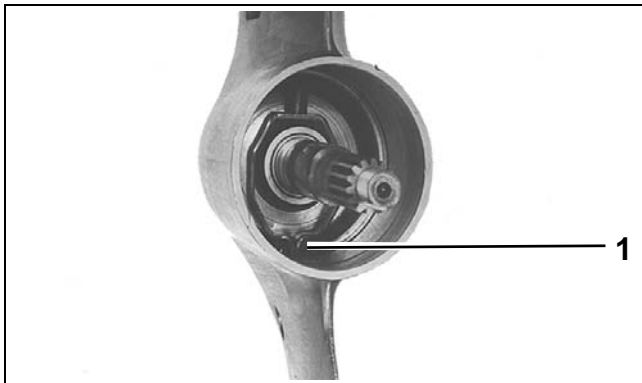

1. Shifter yoke hook

COA3230

Apply *Triple-Guard* grease to threads of lower shift rod and install into gearcase through the water intake opening and engage the shifter yoke.

Thread the shift rod into the shifter yoke until the rod bottoms in the yoke.



1. Lower shift rod

007672

## Propeller Shaft Bearing Housing Installation

Slide the retainer plate down the propeller shaft and into the gearcase with tab facing down.

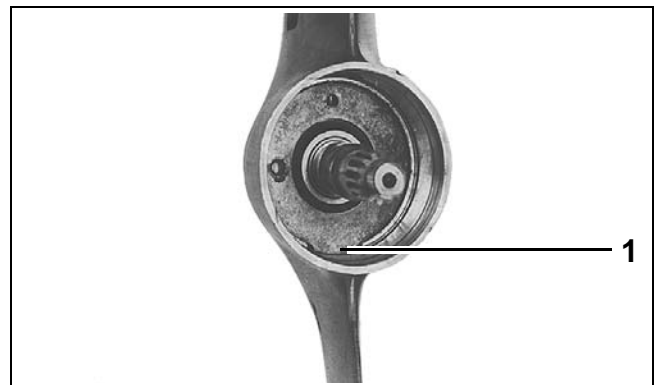

1. Tab, retainer plate

COA3238

### **WARNING**

**Wear safety glasses and proceed with care to avoid unsnapping the ring from the pliers.**

Using Retaining Ring Pliers, P/N 331045, install the retaining ring into groove in gearcase with sharp outside edge facing aft.

**NOTICE** The retaining ring is under extreme pressure during installation. Make sure that the ring is seated in groove.

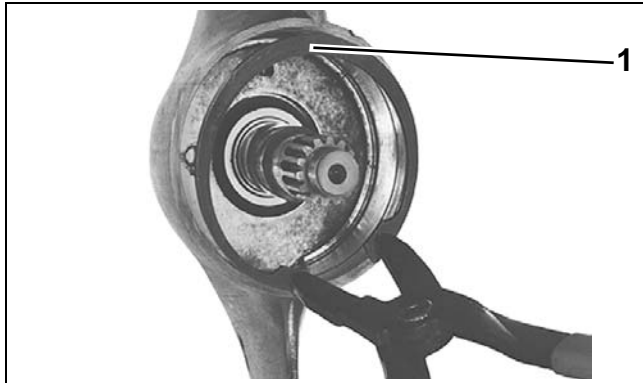

1. Retaining ring COA3239

Thread one Guide Pin, P/N 383175, into the retainer plate.

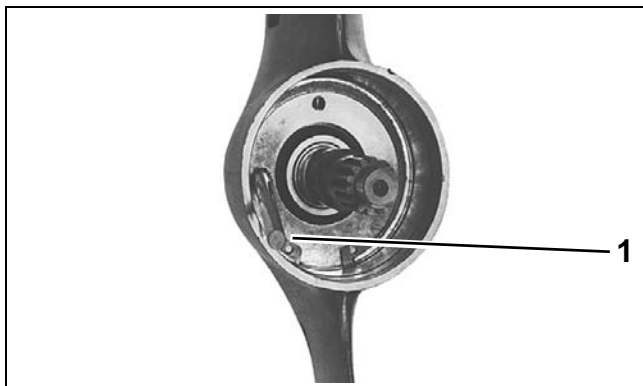

1. Guide pin COA3240

Use *Needle Bearing* grease to temporarily hold the reverse gear thrust washer on the back of the propeller shaft bearing housing.



1. Reverse gear thrust washer COA3309

Lightly apply *Gasket Sealing Compound* to the aft support flange of the bearing housing. Align the propeller shaft bearing housing on the guide pin with the word "UP" toward the top.

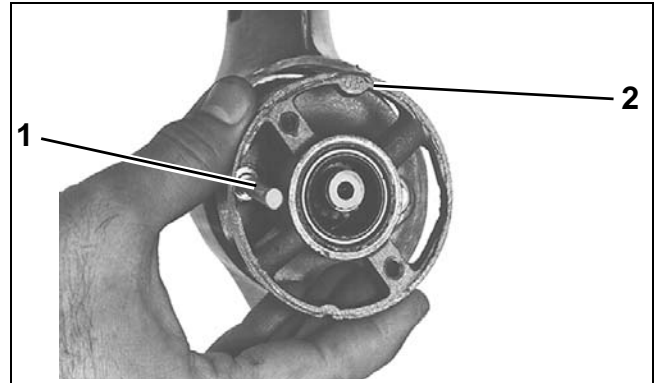

1. Guide pin  
2. "UP" COA3241

Using a brass punch and a mallet, seat the bearing housing in the gearcase.



38639

Place new O-rings on the bearing housing retaining screws. Apply *Gasket Sealing Compound* to the O-rings and threads of the screws.

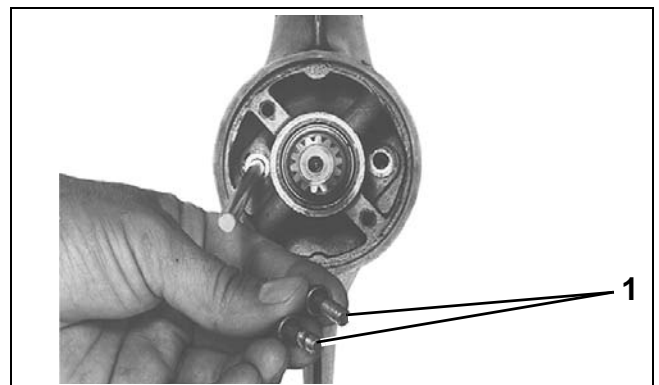

1. Screws COA3243

---

## GEARCASE

### GEARCASE ASSEMBLY

---

Install one screw in the bearing housing. Remove the guide pin and install the second screw. Tighten screws to a torque of 124 to 142 in. lbs. (14 to 16 N·m).

Apply *Adhesive 847* to the bottom of a new exhaust seal assembly and install it into the slot in the gearcase.

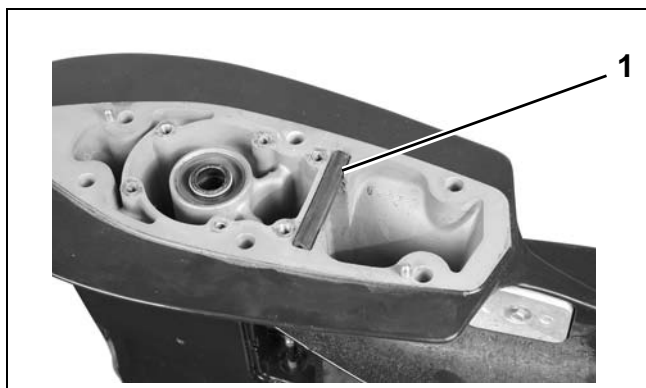

1. Seal assembly

007667

To complete gearcase assembly, refer to:

- **WATER PUMP SERVICE** on p. 250
- **GEARCASE LEAK TEST** on p. 247
- **GEARCASE REMOVAL AND INSTALLATION** on p. 248
- **Gearcase Lubricant** on p. 34
- **Propeller Hardware Installation** on p. 246
- **Trim Tab Adjustment** on p. 27.

During break-in period of a reassembled gearcase, change the gearcase lubricant between 10 to 20 hours of operation.

---

# TRIM AND TILT

## TABLE OF CONTENTS

SERVICE CHART .....	268
SYSTEM DESCRIPTION .....	269
MANUAL ADJUSTMENT .....	269
TRAILERING BRACKET AND TILT SUPPORT .....	269
ROUTINE INSPECTIONS .....	270
GENERAL .....	270
RESERVOIR FLUID .....	270
MANUAL RELEASE VALVE .....	270
STERN BRACKETS .....	270
TROUBLESHOOTING .....	270
ELECTRICAL CIRCUIT TESTS .....	271
RELAY TESTING .....	271
TRIM AND TILT MOTOR CURRENT DRAW TESTS .....	271
TRIM AND TILT MOTOR NO LOAD TEST .....	272
TRIM GAUGE TEST .....	272
TRIM SENDER TEST .....	273
TRIM AND TILT REPLACEMENT .....	273
REMOVAL .....	273
INSTALLATION .....	274
TRIM AND TILT SERVICE .....	275
DISASSEMBLY .....	275
ASSEMBLY .....	276

# SERVICE CHART

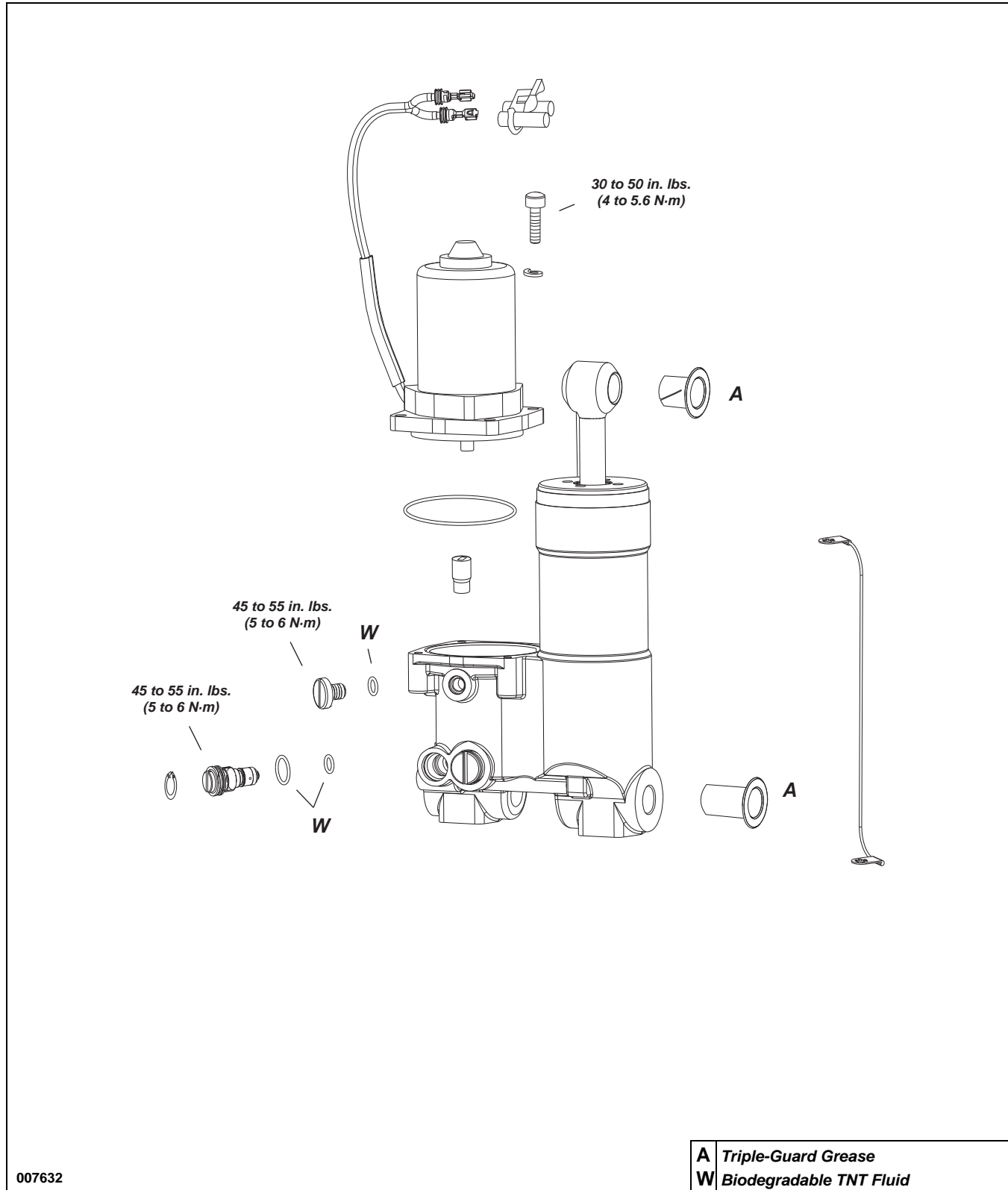

## SYSTEM DESCRIPTION

The power trim/tilt hydraulic system is completely contained between the outboard's stern brackets.

The system consists of:

- Electric motor
- Oil reservoir
- Pump manifold assembly
- Cylinder body assembly

Optimal boat and outboard performance can be achieved by adjusting (trimming) the angle of outboard propeller thrust. The first 15° of outboard movement is considered trim range.

Outboard movement beyond the trim range is considered tilting. Tilting of the outboard may be desired for shallow water drive and for trailering/storage. The tilt cylinder moves the outboard through the tilt range.

**IMPORTANT:** When in tilt range, make sure water is available to gearcase water pickups.

### Manual Adjustment

The outboard can be manually raised or lowered through its entire trim and tilt range by opening the manual release valve a minimum of three turns. When this cycle is complete, the manual release valve must be closed and tightened to a torque of 45 to 55 in. lbs. (5 to 6 N·m) before normal operation can be resumed.

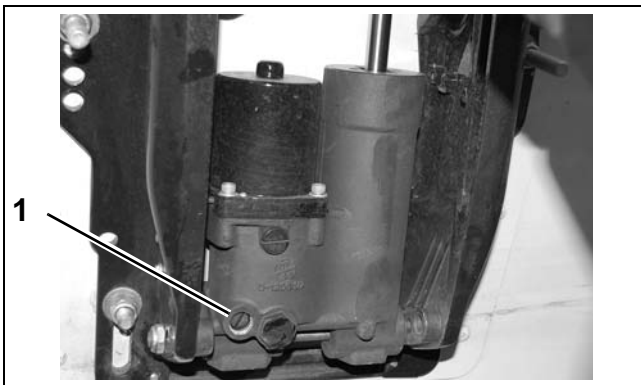

1. Manual release valve, 40-60 HP

008018

### Trailering Bracket And Tilt Support

These outboards are equipped with combination tilt support/trailering brackets.

Tilt the outboard up fully, engage the bracket, then tilt the outboard down until the bracket is firmly in position.



1. Trailering locks

007636

## ROUTINE INSPECTIONS

### General

Check for external signs of fluid leakage. Correct causes as necessary.

Check the battery and make sure it is in good operating condition.

### Reservoir Fluid

Check reservoir fluid level at least every three years or 300 operating hours. System capacity is approximately 15.2 fl. oz. (450 ml).

**IMPORTANT:** Use only *Evinrude/Johnson* Bio-degradable TNT Fluid to fill the hydraulic system.

Refer to **Trim and Tilt** on p. 35 for filling procedure.

### Manual Release Valve

Check the manual release valve with a torque wrench.

**IMPORTANT:** Tighten valve to a torque of 45 to 55 in. lbs. (5 to 6 N·m).

### Stern Brackets

Inspect the stern brackets for binding.

Tighten starboard tilt tube nut to a torque of 45 to 50 ft. lbs. (61 to 68 N·m).

## TROUBLESHOOTING

Use the following guidelines to check a single piston trim/tilt unit that is not working correctly.

### Cylinder Leakdown:

- Manual release valve seals
- External leaks

### No reverse lock:

- External leaks

### No operation, motor runs:

- Manual release valve open
- Fluid level low
- Pump coupler
- Hydraulic pump

### No tilt down:

- Manual release valve
- Fluid level

### Slow performance:

- Manual release valve
- Fluid level low
- Mechanical binding
- Electric motor
- Hydraulic pump

### Unit locked in tilt up:

- Mechanical binding
- Hydraulic pump



# ELECTRICAL CIRCUIT TESTS

## Relay Testing

When the trim-UP button is pressed, the UP relay is energized and connects the blue trim motor wire to the battery positive (+) terminal. The green trim motor wire remains grounded. When the button is released, the blue trim motor wire returns to a grounded position.

When the trim-DOWN button is pressed, the DOWN relay is energized and connects the green trim motor wire to the battery positive (+) terminal. The blue motor wire remains grounded. When the button is released, the green trim motor wire returns to a grounded position.

Refer to **TILT/TRIM RELAY TEST** on p. 100 for relay testing procedure.

## Trim and Tilt Motor Current Draw Tests

Careful analysis of the electric motor's current draw and trim/tilt unit operating speed aids evaluation of the electric motor and certain mechanical components.

Use a battery rated at 360 CCA (50 Ah) or higher that is in good condition and fully charged to perform this test.

**IMPORTANT:** Specifications are for static hydraulic tests. DO NOT attempt to perform the following tests while the boat is moving.

Connect a 0 to 100 A DC ammeter in series between the battery side of the starter solenoid and the red lead to the trim/tilt relay module.

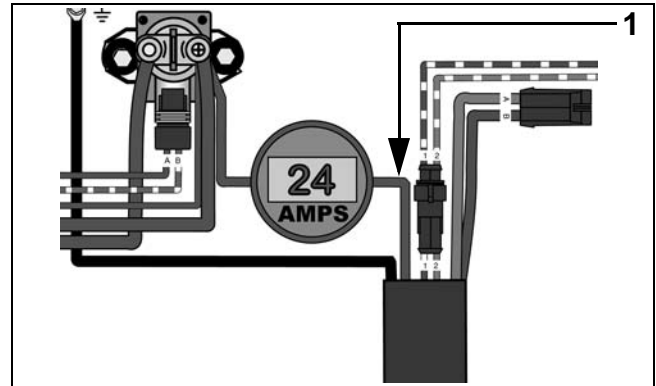

1. Red lead

005441

Observe ammeter and a stopwatch while running hydraulic unit through several complete cycles.

Compare test results to the values listed:

Mode	Normal Current Draw	Time in Seconds
Stall UP	11 to 16 Amps	–
Stall DOWN	16 to 22 Amps	–
Full Range UP	–	13 to 19
Full Range DOWN	–	10 to 16

Test results include three basic possibilities:

### A. Low current draw – Check for:

- Valves leaking
- Pump damaged
- O-rings leaking
- Manual release valve damaged

### B. High current draw – Check for:

- Valves sticking
- Pump binding
- Motor binding
- Cylinder binding

### C. Normal current draw, slow operating speed – Check for:

- Manual release valve damaged

## TRIM AND TILT ELECTRICAL CIRCUIT TESTS

### Trim and Tilt Motor No Load Test

**IMPORTANT:** Securely fasten motor in a suitable fixture before proceeding with this test.

Use a battery rated at 360 CCA (50 Ah) or higher that is in good condition and fully charged to perform this test.

Connect a 0 to 25 A ammeter in series with the battery positive (+) terminal, ammeter red lead toward terminal.

Attach or hold a vibration or mechanical tachometer to the motor while performing this test.

Monitor motor RPM and current draw.



30957

The motor shaft must rotate clockwise, as viewed from the pump end, when positive (+) is applied to the blue lead, and negative (-) is connected to green lead.

The motor shaft must rotate counterclockwise, as viewed from the pump end, when positive (+) is applied to the green lead, and negative (-) is applied to the blue lead.

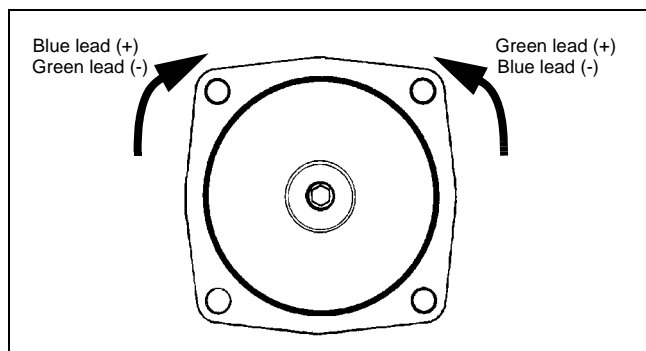

DR4238r

If test results vary, replace the motor.

### Trim Gauge Test

#### STEP 1

Turn key switch ON. Using a voltmeter, check for voltage between the trim gauge "I" and "G" terminals.

- If no voltage, check condition of instrument harness, key switch, and engine 20 A fuse.
- If voltage is shown, go to **STEP 2**.

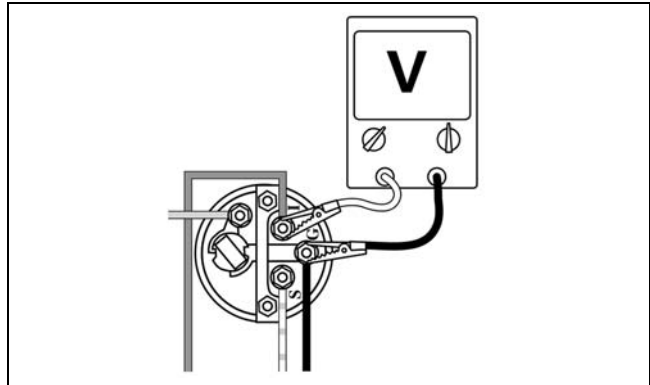

DRC6245

#### STEP 2

Remove the white/tan lead from the trim gauge "S" terminal. With key switch ON, gauge should indicate full-trim DOWN position. Now connect a jumper wire between terminals "S" and "G." Gauge should indicate full-trim UP position.

- If results are different, replace the trim gauge.
- If results agree, refer to **Trim Sender Test** on p. 273.

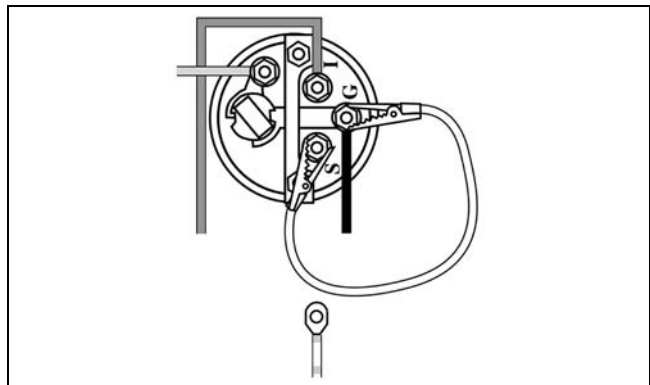

DRC6246A

## Trim Sender Test

**IMPORTANT:** To avoid immediate meter damage, never apply an ohmmeter to an electrical circuit where voltage is present.

Disconnect the 3-pin connector between the instrument harness and engine trim harness. Connect an ohmmeter between the white/tan wire, terminal "C," of the engine harness and a clean engine ground.

With the outboard fully DOWN, meter must show a reading above 80 ohms.

With the outboard fully UP, meter must show a reading below 10 ohms.

- If results agree, refer to **Trim Gauge Test** on p. 272.
- If results are different, replace trim sender.

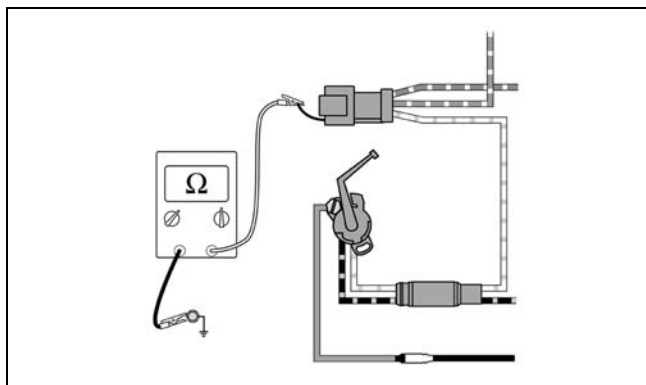

DRC6247

## TRIM AND TILT REPLACEMENT

### Removal

Raise the outboard and engage the tilt support.

Remove the rubber grommet from the blue/green trim/tilt cable connector.

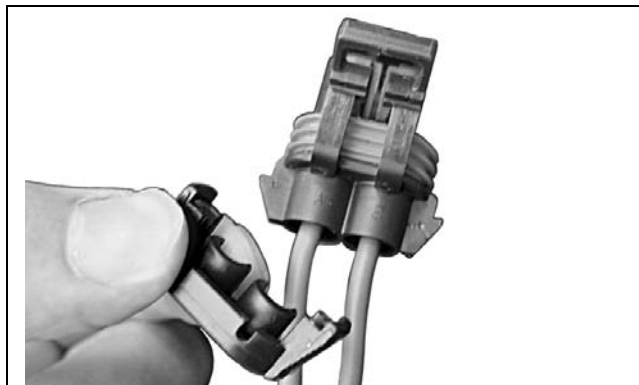

000686

Remove the terminals from the connector by using a suitable tool to depress the tab. While the tab is depressed, pull on the wire from the rear of the connector to release it from the connector.



000687

Separate the trim/tilt unit wires in the braided tube to permit removal through the hole in the stern bracket.

## TRIM AND TILT

### TRIM AND TILT REPLACEMENT

Remove the clip from the cylinder pin.

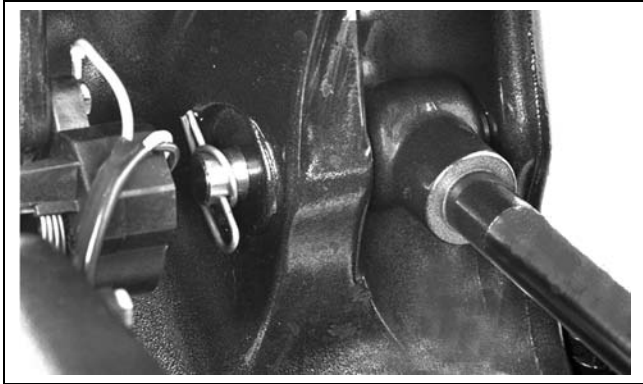

15493

Thread Adapter, P/N 340624, onto Slide Hammer, P/N 391008. Screw the adapter into the cylinder pin and remove the pin.

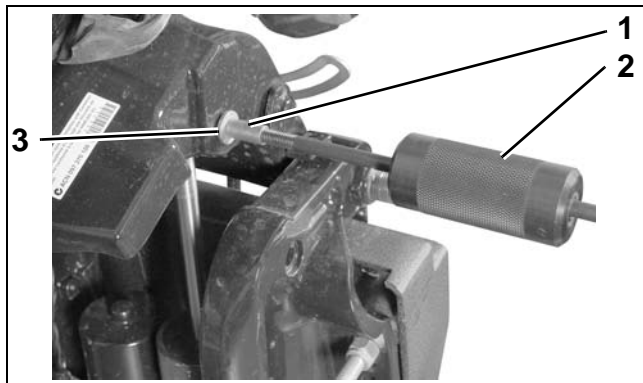

1. Adapter
2. Slide hammer
3. Cylinder pin

007638

Remove one of the locknuts from the angle adjustment rod. Remove the rod from the stern brackets.

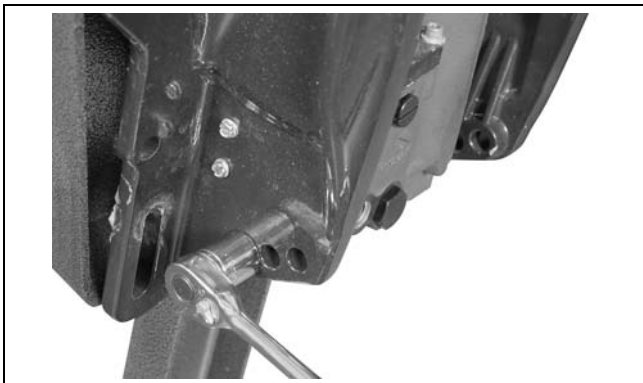

007639

Remove the unit from the stern brackets far enough to remove the ground lead from the pump motor mounting screw.

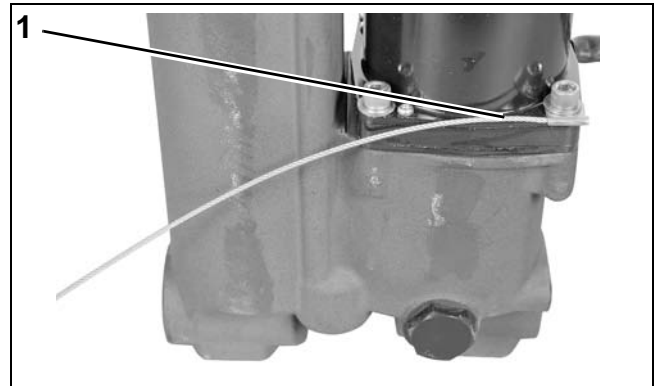

1. Ground lead

007640

## Installation

Lubricate the cylinder and thrust rod bushings with *Triple-Guard* grease. Install the bushings.

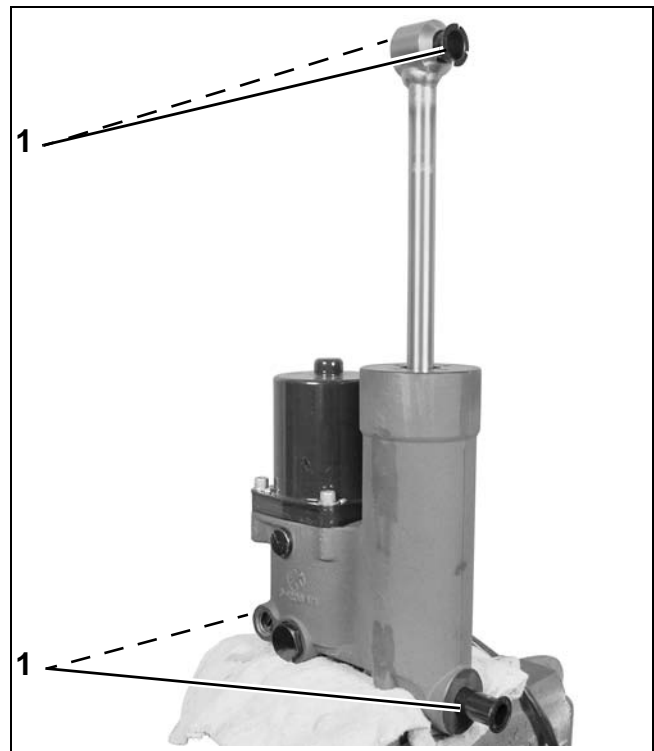

1. Bushings

007648

Install the ground lead.

Place trim/tilt unit into position.

Lubricate the angle adjustment rod with *Triple-Guard* grease. Install the rod. Tighten the locknuts to a torque of 20 to 25 ft. lbs. (27 to 34 N·m).



18941

Loosen the manual release valve if necessary and extend tilt cylinder rod to match with holes in swivel bracket.

Apply *Triple-Guard* grease to upper pin and install the pin.

Secure the cylinder pin with cotter clip.

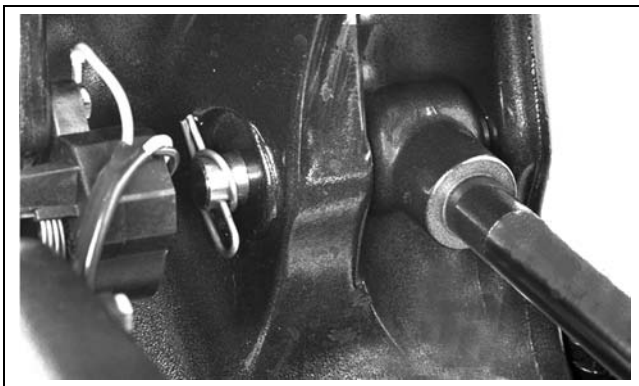

15493

Place trim/tilt wires in braided tube and install through hole in the stern bracket.

Install connector on trim/tilt cable and reconnect trim connectors to engine wire harness.

Release the tilt support and lower the outboard. Tighten the manual release valve to a torque of 45 to 55 in. lbs. (5 to 6 N·m).

## TRIM AND TILT SERVICE

### Disassembly

Thoroughly clean the unit before disassembling. Scrub all outside surfaces with a stiff brush and hot, soapy water to prevent surface dirt from contaminating internal parts.

Always use a lint free shop cloth when handling power trim/tilt components.

If painting the unit is required, paint it after it is completely assembled. Painting of individual components may cause flakes of paint to enter the hydraulic passages during assembly. Tape the trim/tilt piston rods before painting.

### WARNING

**There may be high pressure behind some power trim valves. To avoid injury when removing manual release valve, be sure to cover valve with a shop cloth until the pressure is released. Wear safety glasses.**

**IMPORTANT:** Before removing manual release valve, relieve pressure by fully extending cylinder.

Screw the manual release valve in. Remove the retaining ring using a small pick or screwdriver. Discard the retaining ring.

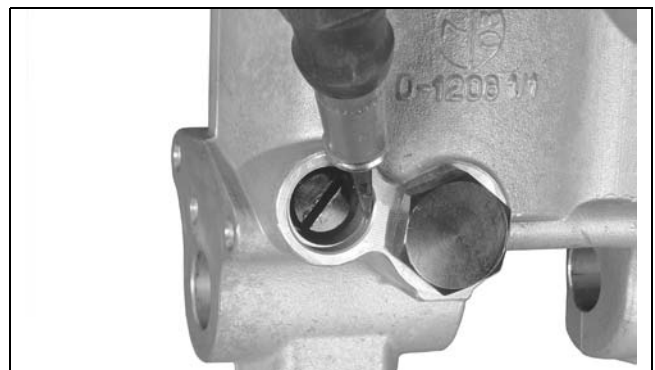

002528

## TRIM AND TILT

### TRIM AND TILT SERVICE

Slowly remove the manual release valve. There may be pressure behind the valve—wear safety glasses.

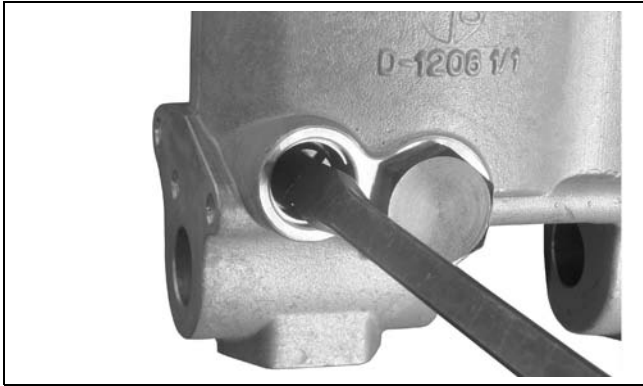

002529

Inspect the manual release valve. Discard the O-rings on the housing.



007108

Remove the four large motor flange retaining screws. Remove the motor and discard O-ring, screws, and washers.

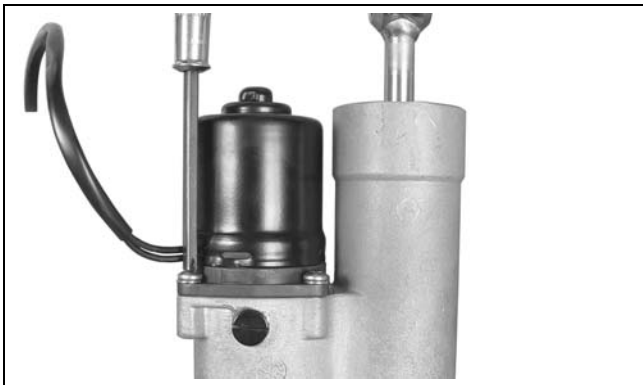

002531

Remove drive coupler from either the motor or the pump assembly.



002532

## Assembly

**IMPORTANT:** Use only *Evinrude/Johnson* Bio-degradable TNT Fluid to fill the hydraulic system.

Install drive coupler in pump assembly.

Install a new motor O-ring.



002533

Position the motor on the manifold and install four **new** screws and lock washers. Tighten the screws 35 to 50 in. lbs. (4 to 5.6 N·m).



002531

Fill the oil reservoir up to the fill plug with *Evinrude/Johnson* Biodegradable TNT Fluid. Install the fill plug.

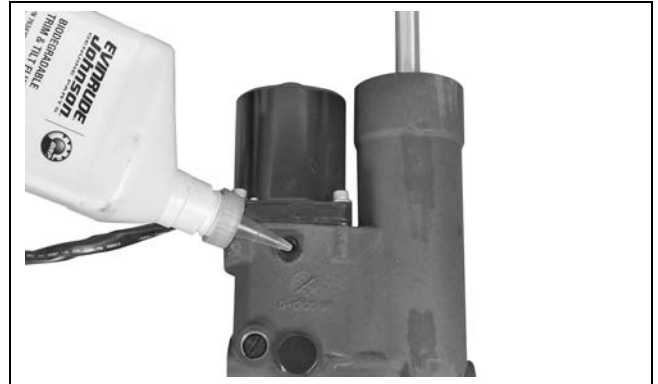

007646

Oil O-rings and install them on the manual release valve. Oil and install the manual release valve. Tighten the valve to a torque of 45 to 55 in. lbs. (5 to 6 N·m).

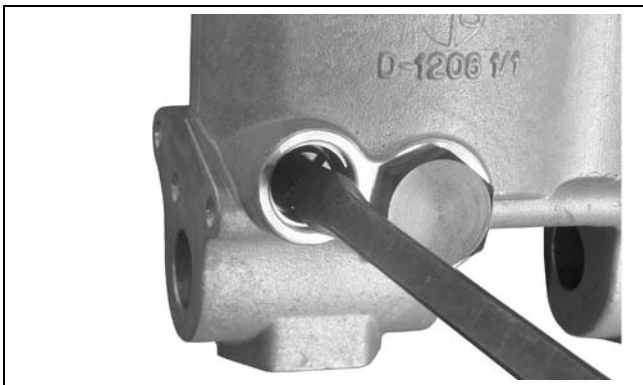

002529

Run the motor, then recheck oil level. Cycle the unit several times and check the oil level when the cylinder is fully extended. Oil should be level with bottom of fill port. Install and tighten the fill plug to a torque of 45 to 55 in. lbs. (5 to 6 N·m).



007647

Install retaining ring in groove.

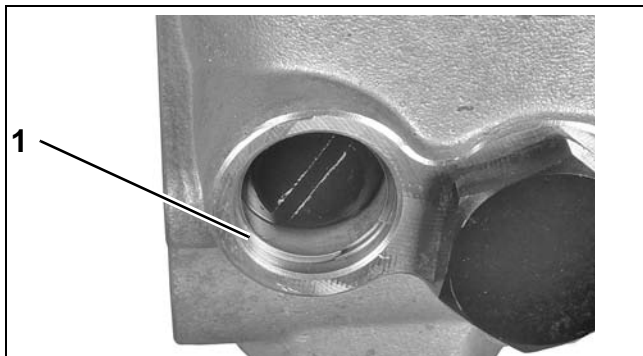

1. Retaining ring

002534





# MANUAL STARTER

## TABLE OF CONTENTS

SERVICE CHART .....	280
RECOIL STARTER REMOVAL .....	281
RECOIL STARTER INSTALLATION .....	282
RECOIL STARTER DISASSEMBLY .....	283
RECOIL STARTER CLEANING AND INSPECTION .....	285
RECOIL STARTER ASSEMBLY .....	286

# SERVICE CHART

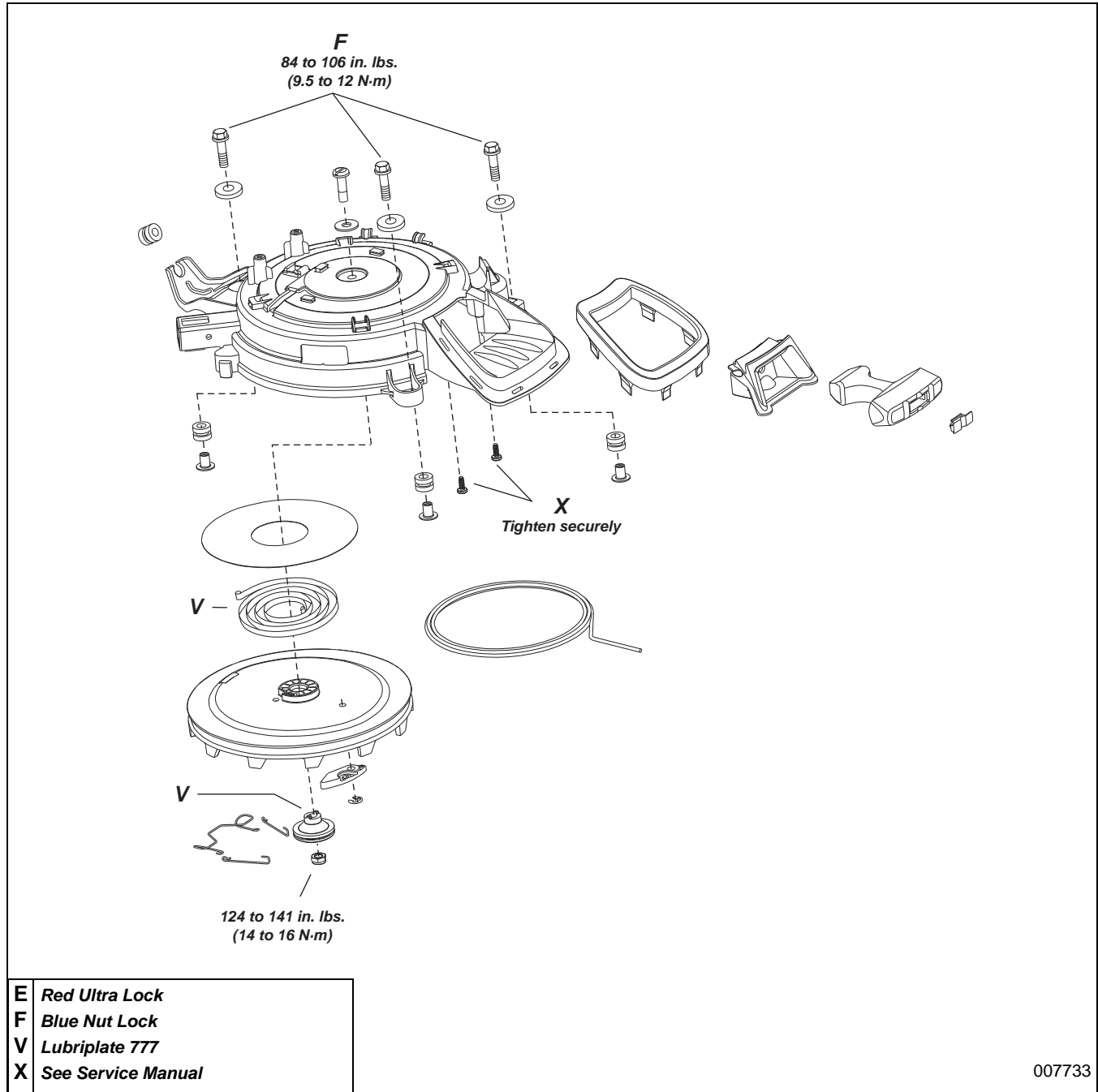

<b>E</b>	<b>Red Ultra Lock</b>
<b>F</b>	<b>Blue Nut Lock</b>
<b>V</b>	<b>Lubriplate 777</b>
<b>X</b>	<b>See Service Manual</b>

007733

# RECOIL STARTER REMOVAL

**⚠ WARNING**

To prevent accidental starting while servicing, twist and remove all spark plug leads.

Remove all electrical connectors from the recoil starter housing.

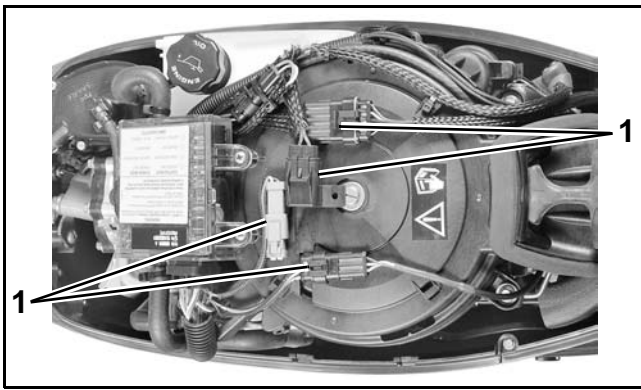

1. Electrical connectors

007241

Remove cooling hose from the *EMM*.

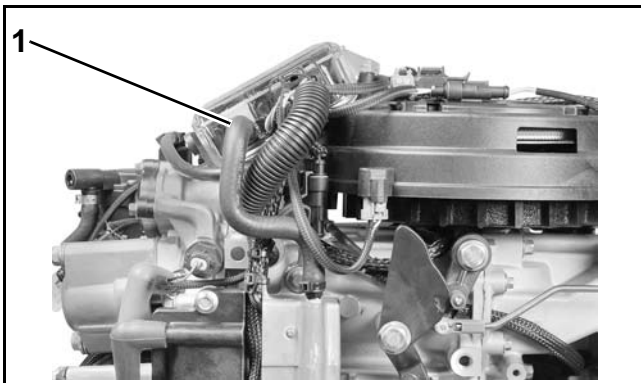

1. Cooling hose

007222

Remove two *EMM* mounting screws and move the *EMM* to the side.

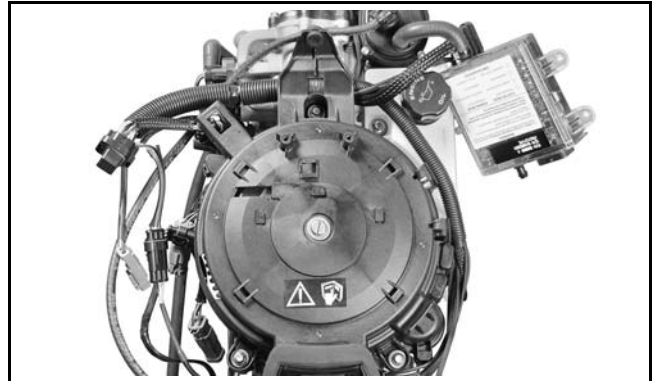

007223

Remove the vapor separator vent hose and wiring from the retainers on the recoil starter housing.

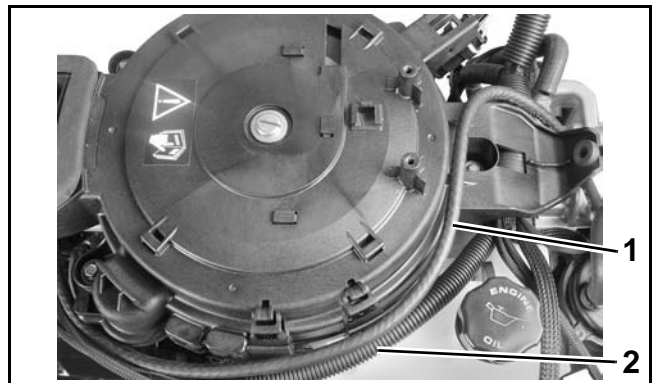

1. Vapor separator vent hose  
2. Wiring

007220

Remove three recoil starter mounting screws. Remove recoil starter assembly.

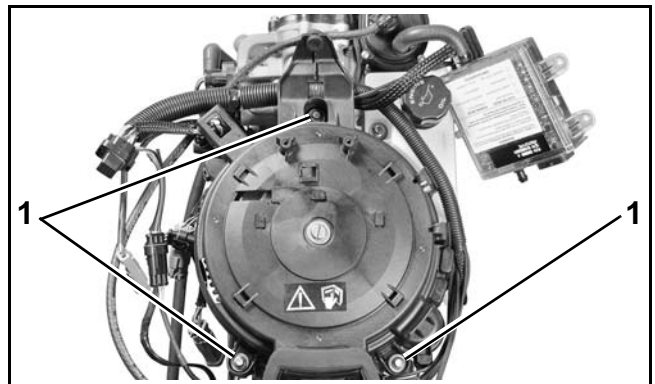

1. Screws

007223

# MANUAL STARTER RECOIL STARTER INSTALLATION

## RECOIL STARTER INSTALLATION

Position the wiring in the retaining bracket of recoil starter housing.

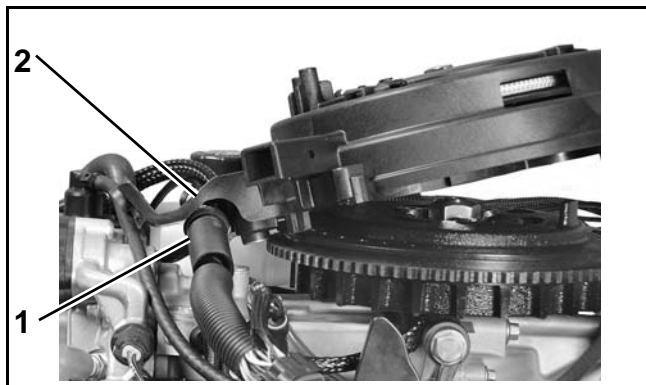

- 2. Wiring
- 3. Retaining bracket

007227

Install recoil starter assembly. Tighten mounting screws to a torque of 31 to 48 in. lbs. (3.5 to 5.5 N-m).

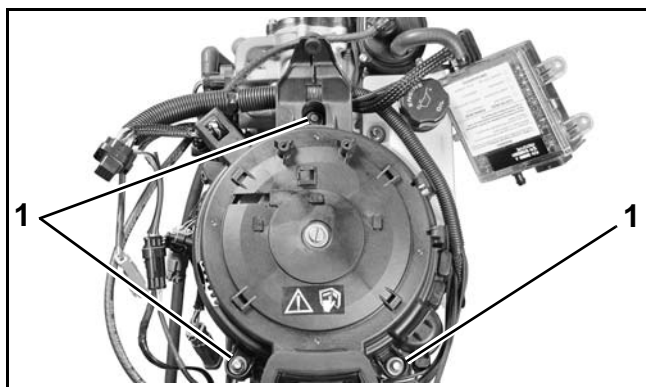

- 1. Screws

007223

Install stator connector in retainer groove of starter housing.

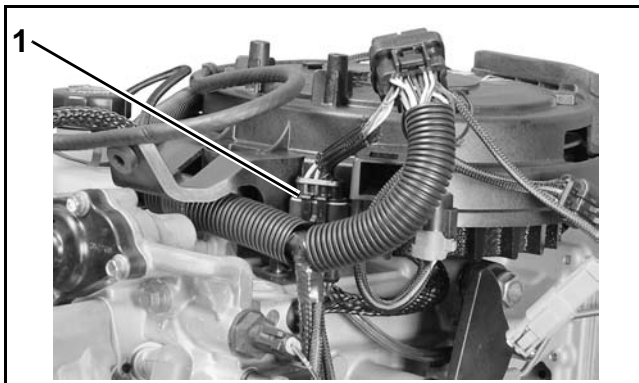

- 1. Stator connector

007229

**NOTICE** To prevent damage to wiring from rotating flywheel, make sure stator connector is securely fastened to the starter housing.

Position the vapor separator vent hose and wiring in the retainers on the recoil starter housing as shown.

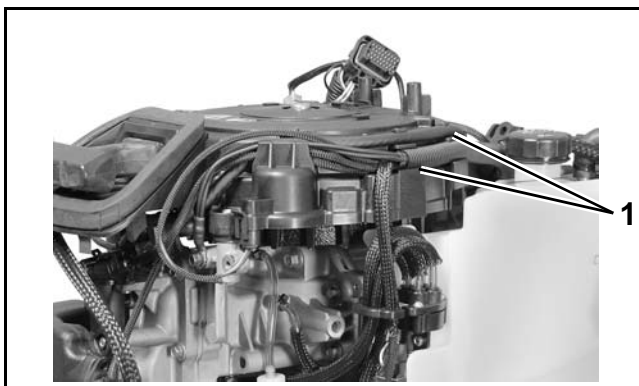

- 1. Retainers

007230

Position the charge module harness, connectors and wiring as shown.

Assemble and tighten tie straps through the tie strap slots of the recoil housing.

Attach fuse holder to retainer.

Attach remaining connectors to retainers on recoil housing as shown.

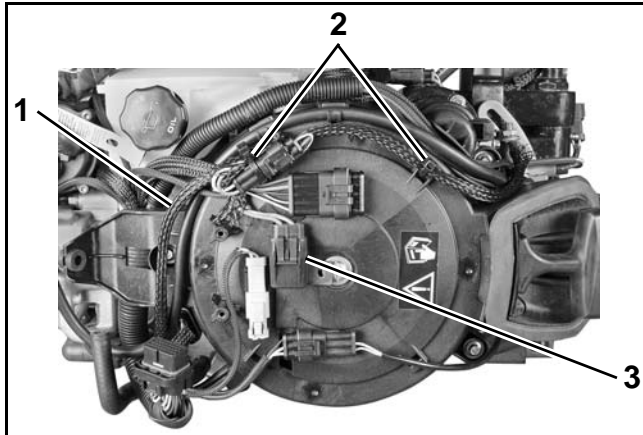

1. Battery charge module harness 007232  
2. Tie straps  
3. Fuse holder

Position the *EMM* on the starter housing. Install and tighten self-taping screws carefully.

**IMPORTANT:** Turn self-tapping screws counter clock-wise to start the threads and clockwise to tighten. Failure to follow this procedure can damage the threads of the housing.

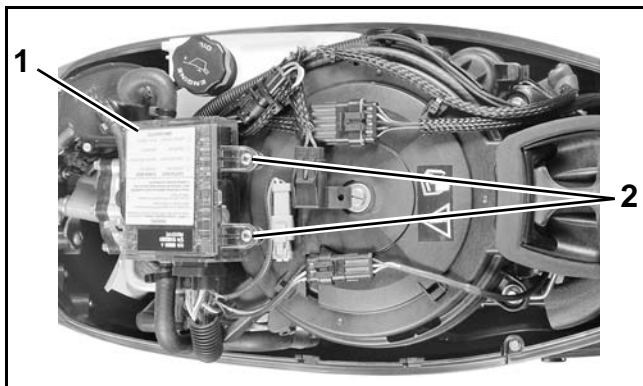

4. *EMM* 007241  
5. Self-taping screws

Connect the cooling hose to the *EMM*. Secure with tie strap.

## RECOIL STARTER DISASSEMBLY

### ⚠ WARNING

**Wear safety glasses while disassembling and assembling manual starters because of rewind spring tension.**

Use Starter Spring Winder and Installer, P/N 342682, to service the recoil starter assembly.

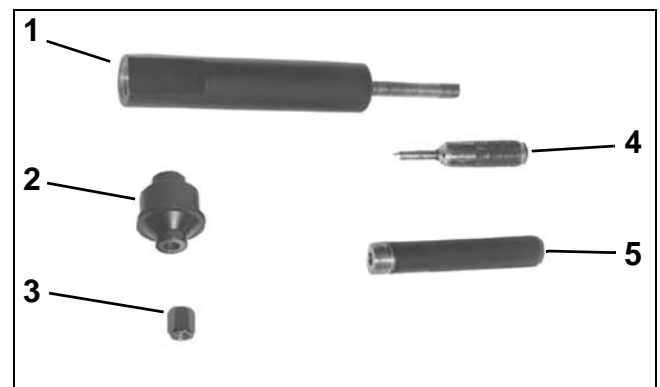

1. Base 50068A  
2. Retainer  
3. Left-hand threaded nut  
4. Stop tool  
5. Handle

Pull the starter rope out completely. Retain pulley in position by placing the stop tool from Starter Spring Winder and Installer, P/N 342682 through the hole in the pulley.

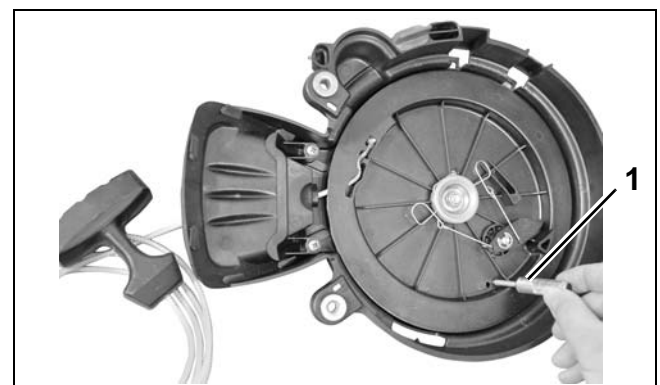

1. Stop tool 007708

# MANUAL STARTER

## RECOIL STARTER DISASSEMBLY

Remove rope from pulley rope channel and untie knot. Remove rope from starter assembly.

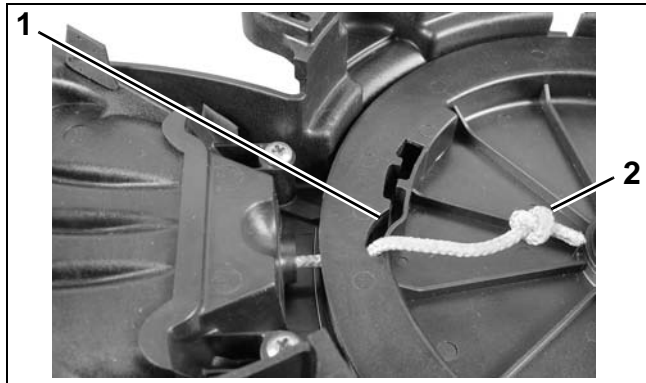

1. Rope channel  
2. Knot  
007709

Remove stop tool and slowly unwind pulley until tension is released from spring.

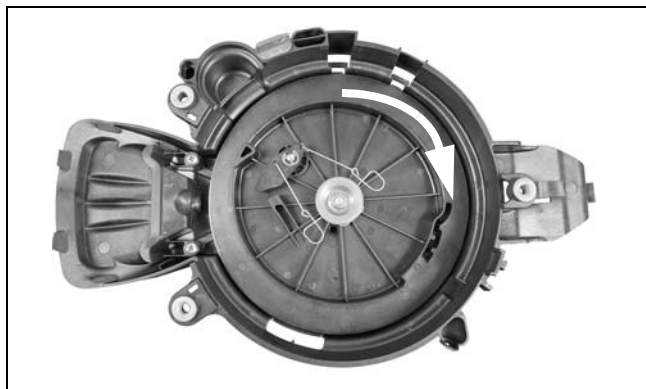

007710

Remove starter spindle screw and lock nut.

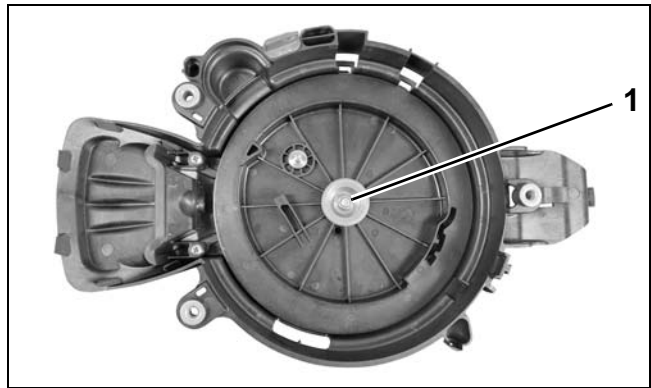

1. Lock nut  
007711

**IMPORTANT:** Hold pulley down in housing and lift out spindle. Carefully lift out pulley, leaving spring in housing.

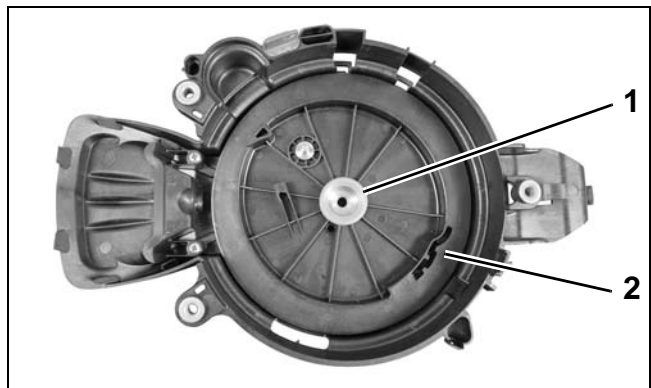

1. Spindle  
2. Pulley  
007712

Remove retaining ring, pawl and linkage.

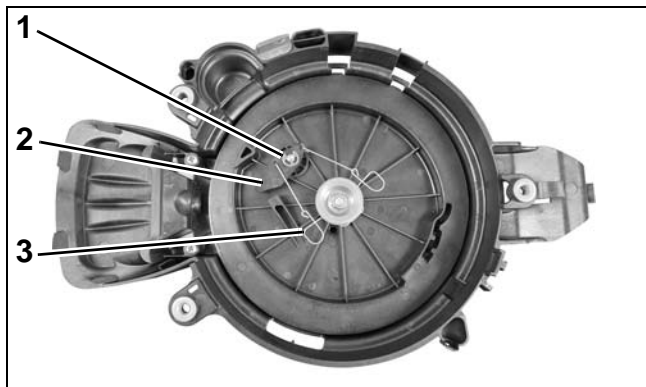

1. Retaining ring  
2. Pawl  
3. Linkage  
007710

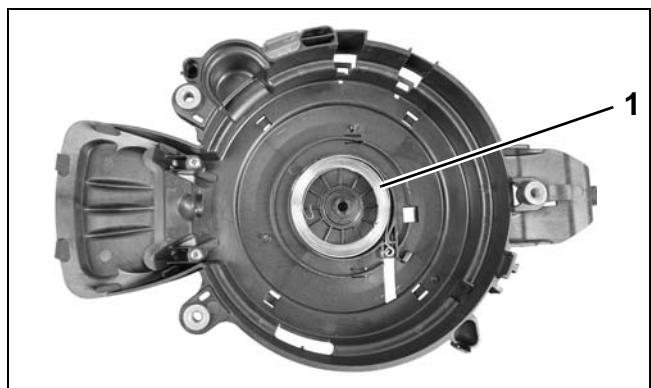

1. Spring  
007713

Turn housing over and tap on bench to remove spring.

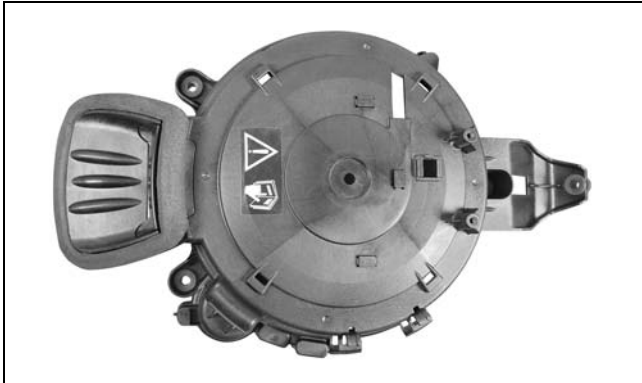

007714

**⚠ WARNING**

**Keep fingers away from uncoiling spring.**

**Do NOT remove spring with housing facing up. Do NOT lift spring out of housing by hand or with pliers.**

**Spring is under tension and will cause injury if accidentally released.**

## RECOIL STARTER CLEANING AND INSPECTION

Wash metal components in solvent and dry with compressed air.

Inspect the rewind spring for broken end loops and weak tension.

Examine the starter pawl for wear.

Inspect the starter components for wear. Replace as necessary.

Inspect starter rope. Replace rope if frayed. Cut new rope 80 in. (203 cm) in length. Fuse ends of rope to a length of 1/2 in. (12 mm).

Examine the pulley and the starter housing. Look for sharp edges and rough surfaces that could fray the starter rope. File and polish to remove.

Examine the starter. Replace any worn or damaged parts.

Remove two screws. Remove the rope guide.

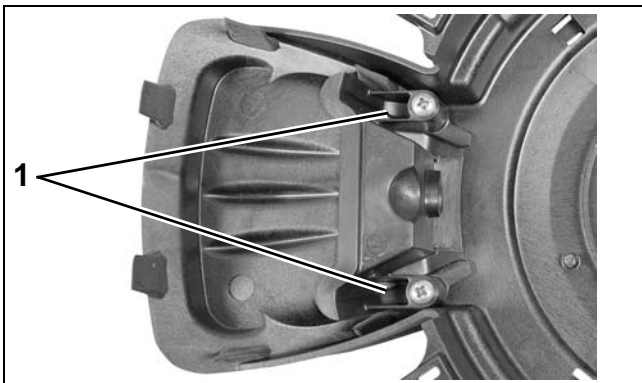

1. Screws

007715

**MANUAL STARTER**  
**RECOIL STARTER ASSEMBLY**

# RECOIL STARTER ASSEMBLY

**⚠ WARNING**

**Wear safety glasses while disassembling and assembling manual starters because of rewind spring tension.**

If removed, install the rope guide to the starter housing. Tighten screws securely.

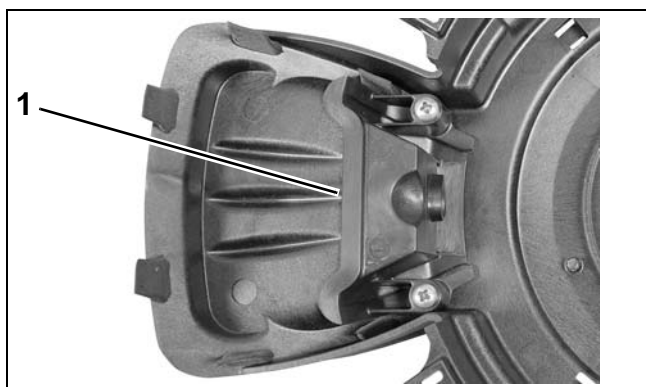

1. Rope guide

007715

Apply *Moly Lube* to both sides of pulley spring shield. Place shield on pulley as shown.



007718

Clamp base of Starter Spring Winder and Installer, P/N 342682, in a vise. Place spring around base as shown.

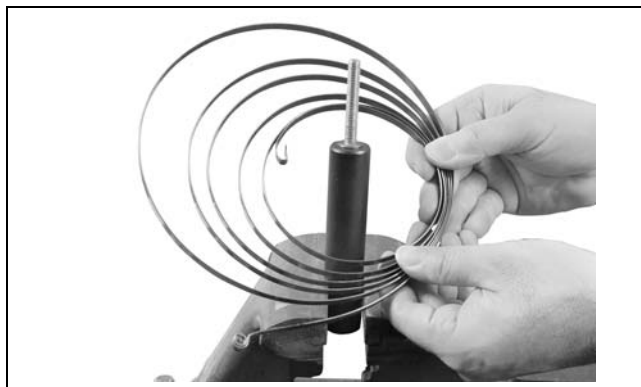

007716

Place starter housing over base.

Route the hook end of spring through the starter housing opening as shown. To keep spring in position, hold up on portion of spring that is outside of the housing.

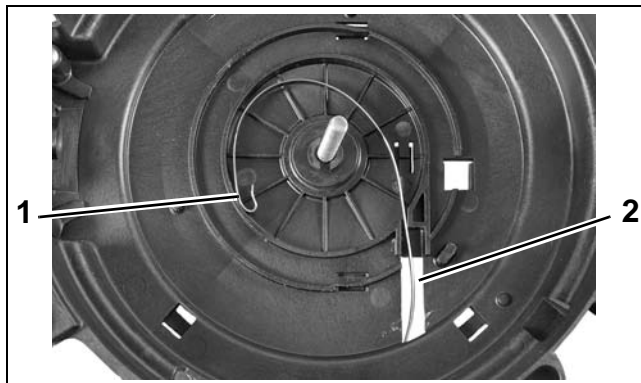

1. Spring hook end  
2. Opening

007717

Place pulley over base and place retainer over pulley. Be sure tapered end of retainer is toward



# MANUAL STARTER RECOIL STARTER ASSEMBLY

pulley. Secure retainer with left-hand threaded nut.



1. Retainer tapered end 007719

Turn pulley counterclockwise 3.5 turns, until the pulley rope channel aligns with the rope guide.

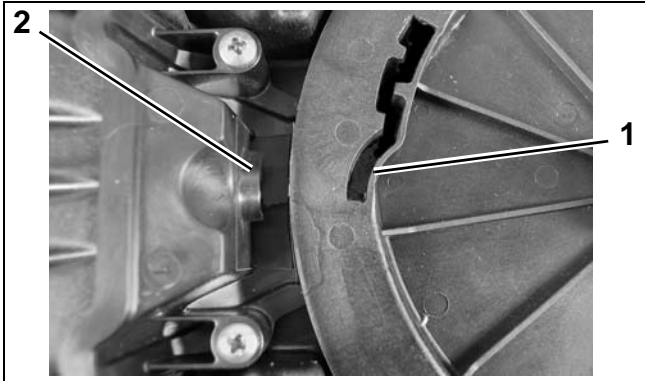

1. Rope channel 007734  
2. Rope guide

Install handle on pulley pin. Pull lightly on spring and turn pulley counterclockwise with handle until hook end of spring engages the pulley.

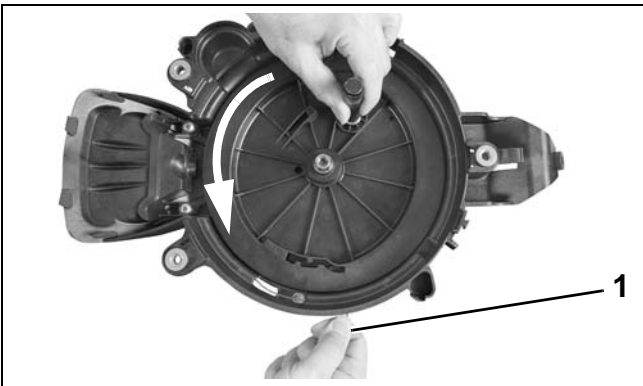

1. Pull on spring 007720

Secure pulley by placing stop tool through the holes in the pulley and housing.

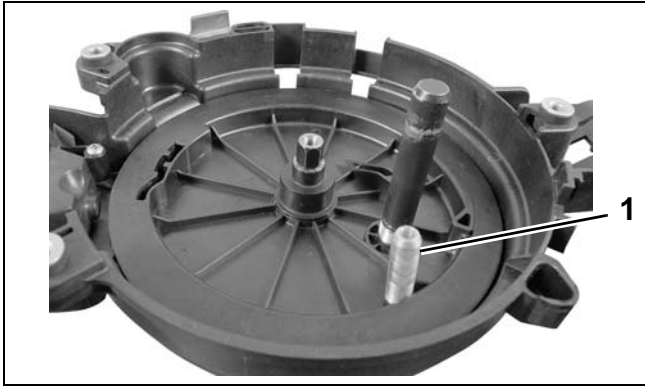

1. Stop tool 007721

Turn pulley counterclockwise until spring is completely pulled into housing.

Allow pulley to slowly unwind until tension is relieved.

If replacing rope, pull new rope through handle. Tie a knot as shown.

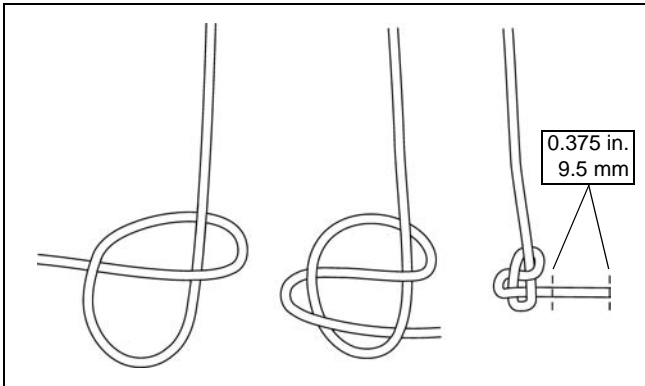

Handle Knot Detail 007722

# MANUAL STARTER

## RECOIL STARTER ASSEMBLY

Route rope through the rope guide and into the pulley rope channel.

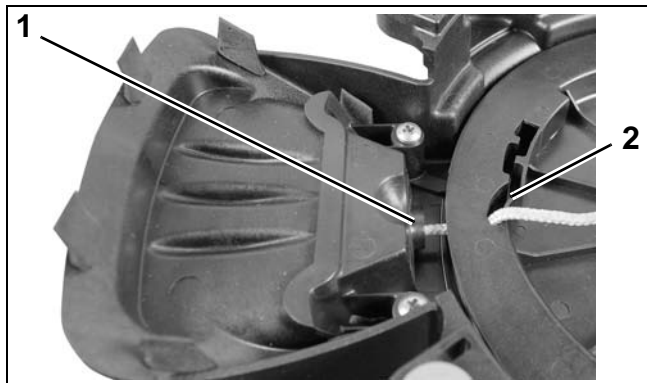

- 1. Rope guide
- 2. Rope channel

007723

Remove left-hand threaded nut and retainer from tool base. Remove starter assembly.

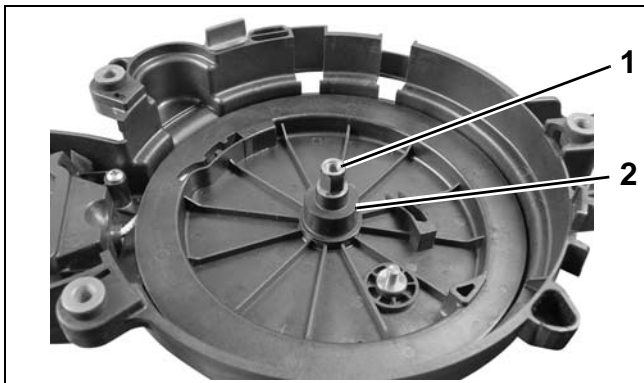

- 1. Left-hand threaded nut
- 2. Retainer

007727

Tie a knot in the end of the rope as shown.

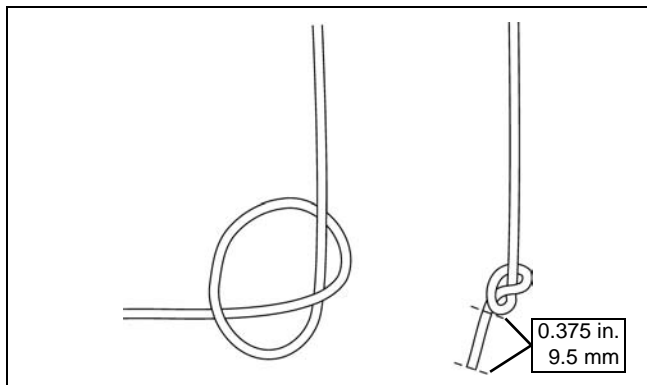

Pulley Knot Detail

007724

Install spindle, screw and lock nut. Tighten nut to a torque of 124 to 141 in. lbs. (14 to 16 N-m).

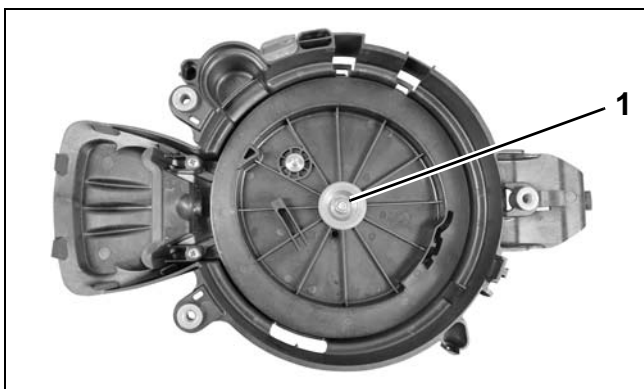

- 1. Lock nut

007711

Use an appropriate tool to place the knot in the channel.

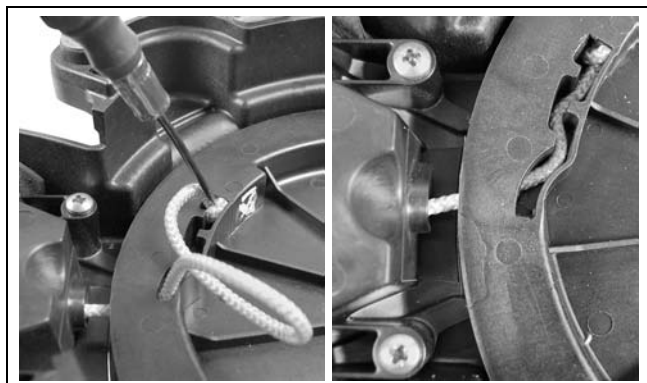

007725  
007726

Install pawl, linkage and retaining ring.

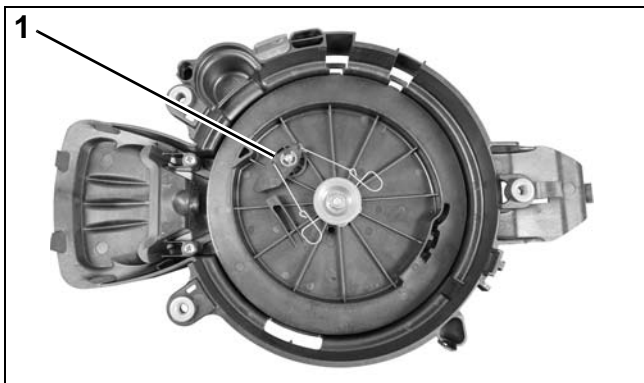

- 1. Retaining ring

007710

Pull rope taut and remove stop tool. Allow rope to slowly wind into starter.

# **SAFETY**

## **TABLE OF CONTENTS**

<b>MARINE PRODUCTS AND THE SAFETY OF PEOPLE WHO USE THEM</b> .....	<b>S-3</b>
OUTBOARD SHIFT SYSTEMS AND SAFETY .....	<b>S-4</b>
OUTBOARD SPEED CONTROL SYSTEM AND SAFETY .....	<b>S-5</b>
OUTBOARD STEERING CONTROL SYSTEM AND SAFETY .....	<b>S-6</b>
OUTBOARD FUEL, ELECTRICAL SYSTEM, AND SAFETY .....	<b>S-8</b>
OUTBOARD MOUNTING SYSTEM AND SAFETY .....	<b>S-11</b>
OUTBOARD HYDRAULIC TILT/TRIM SHOCK ABSORPTION SYSTEM AND SAFETY .....	<b>S-13</b>
OUTBOARD EMERGENCY STOP SYSTEM AND SAFETY .....	<b>S-14</b>
SUMMING UP .....	<b>S-16</b>
<b>MARINE PRODUCTS AND THE SAFETY OF PEOPLE WHO FIX THEM</b> .....	<b>S-17</b>
HANDLING OUTBOARDS .....	<b>S-17</b>
HANDLING LEAD/ACID BATTERIES .....	<b>S-21</b>
GASOLINE – HANDLE WITH CARE .....	<b>S-22</b>
HAZARDOUS PRODUCTS .....	<b>S-23</b>
SAFETY AWARENESS TEST .....	<b>S-24</b>



# MARINE PRODUCTS AND THE SAFETY OF PEOPLE WHO USE THEM

## WARNING

This Safety section contains information relevant to the safety of boaters and people that service boats. Please read this section carefully and share it with all shop technicians. Always follow common shop safety practices. If you have not had training related to common shop safety practices, you should do so not only to protect yourself, but also to protect the people around you.

It is impossible for this manual to cover every potentially hazardous situation you may encounter. However, your understanding and adherence to the recommendations contained in this manual and use of good judgment when servicing outboards will help promote safety. Always be alert and careful: a good foundation for safety.

Enjoyable boating is the goal of people who design and build marine products. To reach this goal, manufacturers are careful to make sure:

- Product user is informed; and
- Products are safe and reliable.

It is up to you, the people who...

- Rig boats;
- Fix machinery; and
- Maintain equipment

...to keep the products safe **and** reliable.

This section talks about safe boating and how you can help make it safe. Some of these safety issues you will know, others you may not.

### First!

A word about parts... Plain parts; special parts; all parts!

### DO NOT SUBSTITUTE PARTS

“They look the same, but are they the same?”

- Same size?
- Same strength?
- Same material?
- Same type?

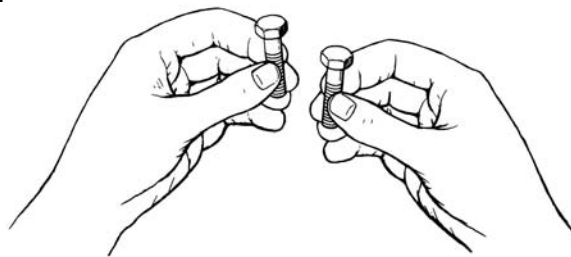

Don't substitute unless **you know** they are the **same** in **all** characteristics.

### Second!

- Special locking bolts and nuts are often used to hold steering, shift, and throttle remote control cables to the outboard.
- When you take any outboard off a boat, keep track of special nuts and bolts. Do not mix with other parts. Store them on the outboard, then they are there when you need them.
- When the outboard is returned to the boat, use only the special nuts and bolts to hold remote steering, shift, and throttle cables to the outboard.

## Outboard Shift Systems and Safety

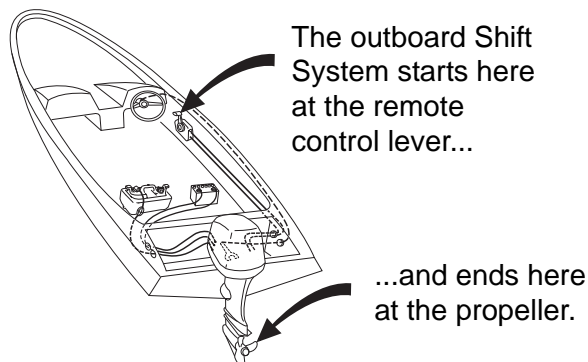

### What is most important?

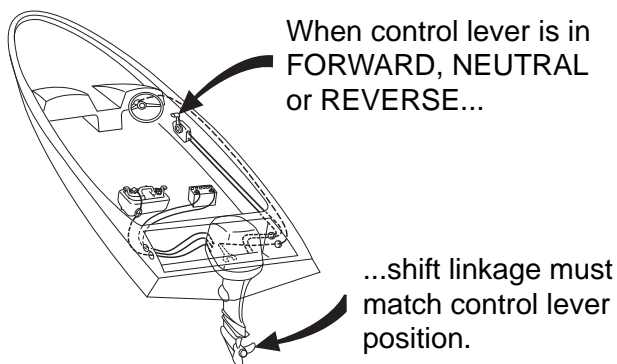

### What could happen?

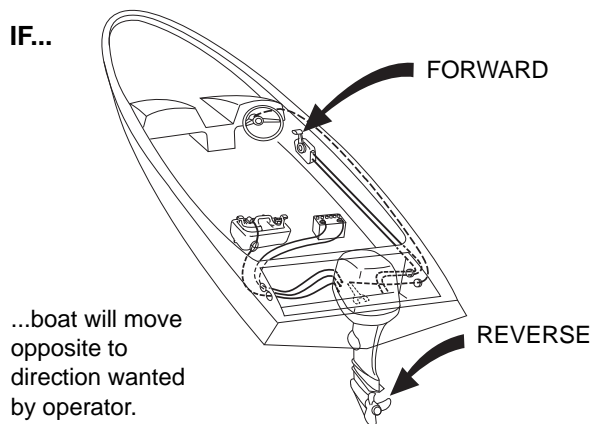
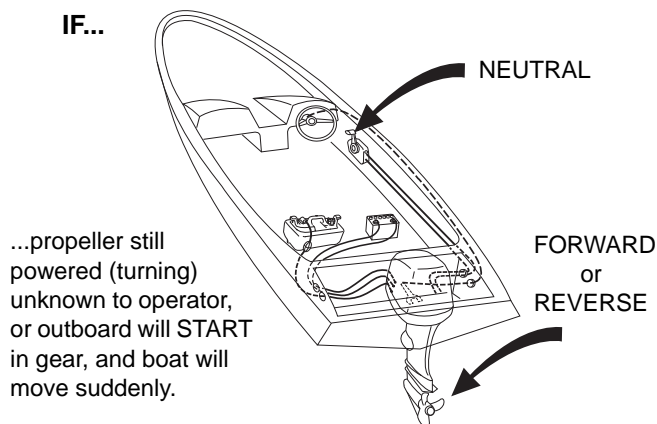

**How can loss of shift control be minimized?**

**When rigging or after servicing**

- Read, understand, and follow manufacturer's instructions
- Follow warnings marked "⚠" closely.
- Assemble parts carefully.
- Make adjustments carefully.
- Test your work. Do not guess. Make sure propeller does just what the operator wants and nothing else.
- Do not shift gears on a stopped outboard. Adjustments can be lost and parts weakened.

## Outboard Speed Control System and Safety

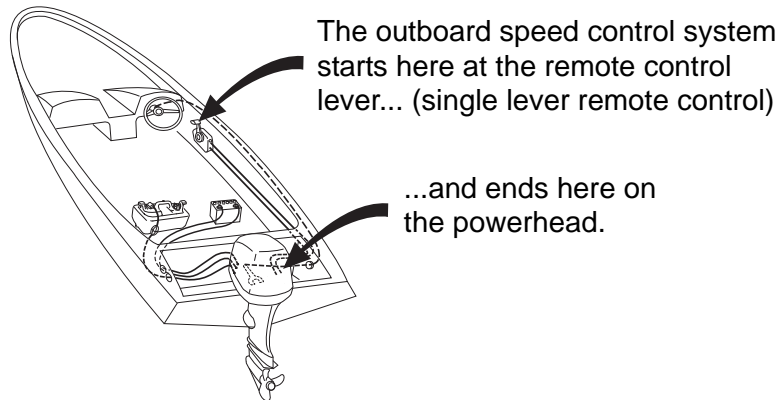

### What is most important?

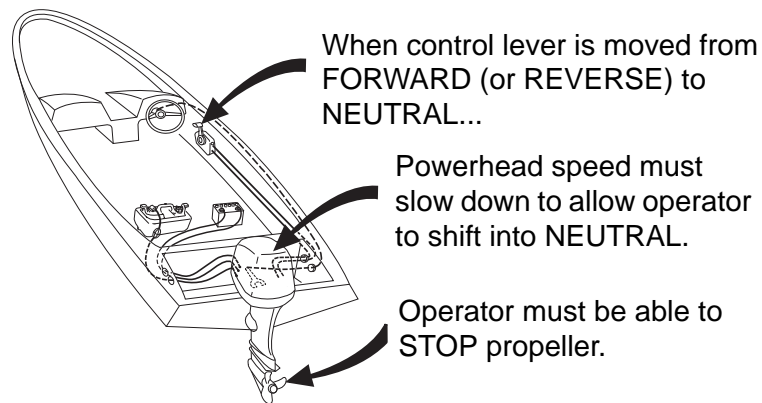

### What could happen?

If Operator cannot slow down the outboard or shift into NEUTRAL gear (stop propeller), Operator could panic and lose control of boat.

### How can loss of speed control be minimized?

#### When rigging or after servicing

#### Read, understand, and follow manufacturer's instructions

- Follow warnings marked "⚠" closely.
- Assemble parts carefully.
- Make adjustments carefully.
- Test your work. Do not guess. Make sure speed control system does just what the operator wants and nothing else.
- Make sure full throttle can be obtained so Operator will not overload parts.

## Outboard Steering Control System and Safety

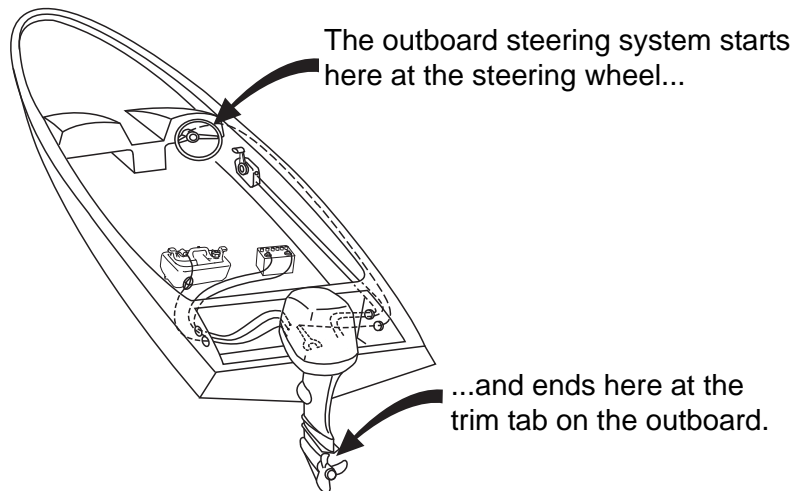

### What is most important?

The steering system:

- Must not come apart;
- Must not jam; and
- Must not be sloppy or loose.

### What could happen?

- If steering system comes apart, boat might turn suddenly and circle. Persons thrown into the water could be hit.

- If steering jams, operator may not be able to avoid obstacles. Operator could panic.
- If steering is loose, boat may weave while operator tries to steer a straight course. With some rigs (at high speed), loose steering could lead to loss of boat control.

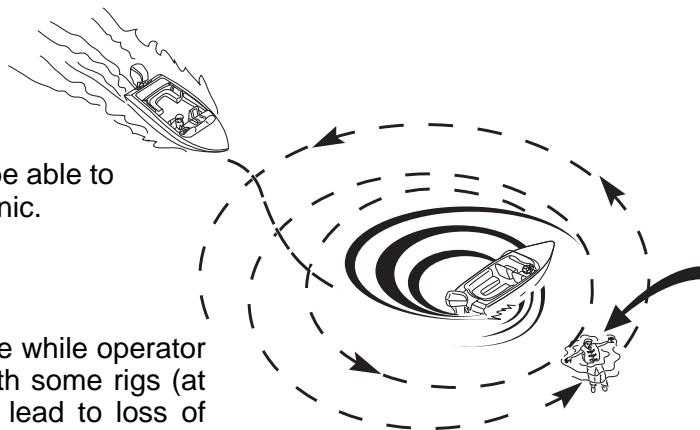



### How can loss of steering control be minimized?

#### When rigging or after servicing

- Use a steering system recommended by the outboard manufacturer which meets Marine Industry Safety Standards (ABYC).
- **Read, understand, and follow** manufacturer's **instructions**
- Follow warnings marked "⚠" closely.
- Assemble parts carefully.
- Make adjustments carefully.
- Keep parts moving freely. Lubricate parts as shown in manual.
- Use the bolts, nuts and washers supplied with steering attachment kits—they are a special locking type that will not loosen, rust, or weaken.

### Transom Mounted Steering Systems – Check to Uncover Possible Trouble!

Tilt outboard into boat, then turn it.

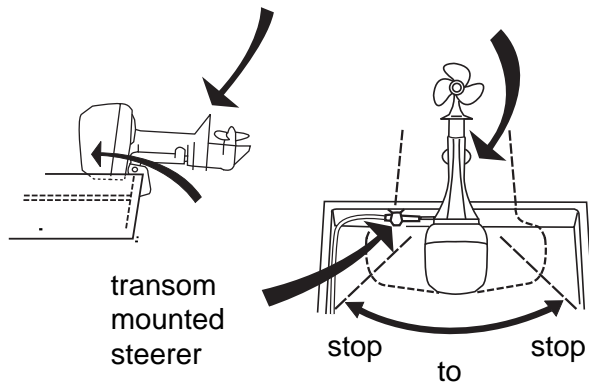

During this procedure, steering parts:

- Must not bind; and
- Must not touch other boat, outboard, or accessory parts in transom area.

**Why?** A hard blow to the outboard's gearcase can result in damage to steering parts.

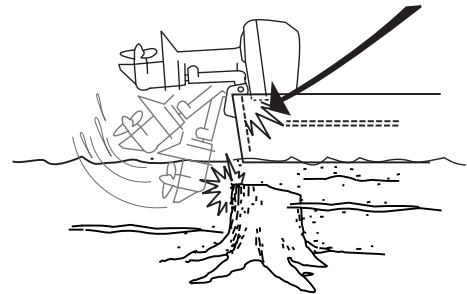

Be aware that raising or lowering outboard on transom can change a set-up which was OK earlier. If moved up or down even one-half inch, run test again to make sure steering parts are free and clear.

Check for damaged parts. Blows to the outboard like this

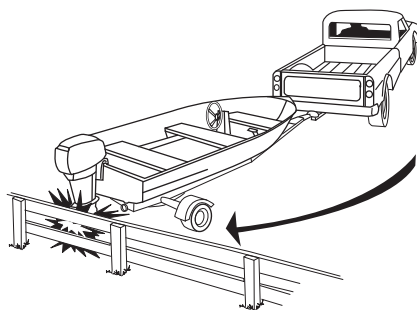

or this can put heavy loads on steering parts. Look for:

- Cracked parts, including steering parts, swivel brackets, and transom brackets;
- Bent parts; and
- Loose nuts and bolts.

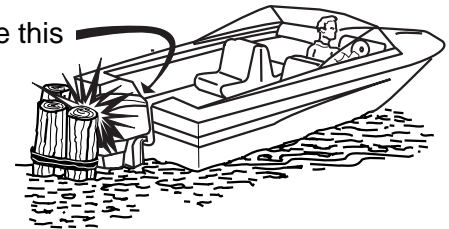

**Replace damaged parts. If weakened, parts could fail later on the water when least expected.**

## Outboard Fuel, Electrical System, and Safety

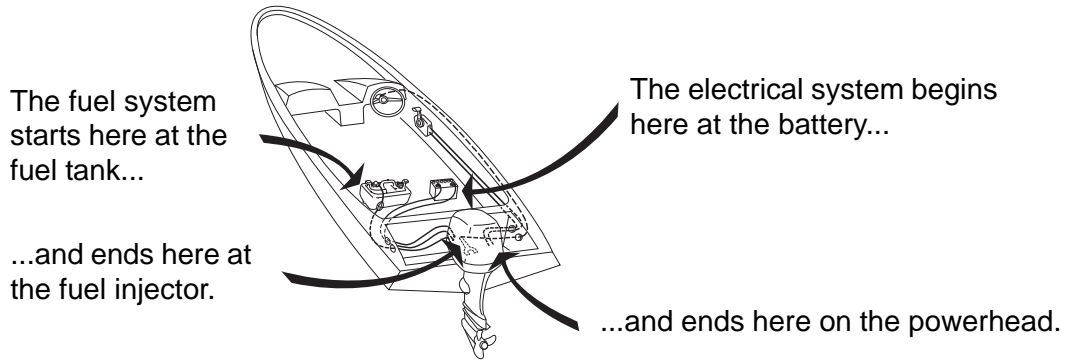

### What is most important?

- Fuel leakage must be eliminated.
- Stray electric sparks must be avoided.

### What could happen?

- **When not boating**, fuel leaking in car trunk or van, or place where portable tank is stored (basement or cottage), could be ignited by any open flame or spark (furnace pilot light, etc.).
- **When boating**, fuel leaking under the engine cover could be ignited by a damaged or deteriorated electrical part or loose wire connection making stray sparks.

### How Can Fire and Explosion Be Minimized?

- **Read, understand, and follow** manufacturer's instructions
- Follow warnings marked "⚠" closely.
- **Do not** substitute fuel or electrical systems parts with other parts which may look the same. Some electrical parts, like starter motors, are of special design to prevent stray sparks outside their cases.
- Replace wires, sleeves, and boots which are cracked or torn or look in poor condition.

When mixing and refueling, always mix gas and oil outside...

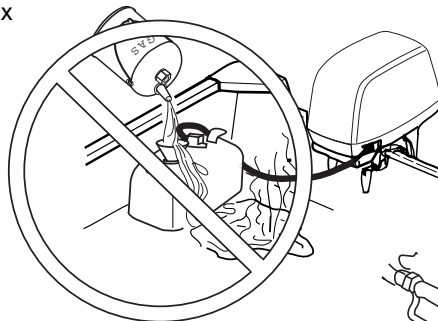

Always fill the tank outside the boat

Fumes are hard to control. They collect and hide in the bottom of the boat.

Remember:



Do not use electrical devices such as cellular phones in the vicinity of a fuel leak or while fueling.



If you use a funnel, it has to be metal to ground the spout to the tank.

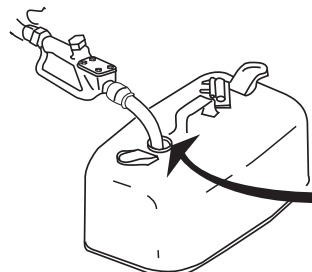

To avoid those static electric sparks, ground (touch) the spout against the tank.

If electrical parts are replaced or even removed from the outboard, check the following:

### Wire and high voltage lead routing

- As shown in service manual
- Away from moving parts which could cut wires or wire insulation
- Away from engine cover latches which can catch and cut insulation from high voltage spark plug leads

### Sleeves, boots, shields

- In position (to avoid shock hazard)
- Not torn or cracked

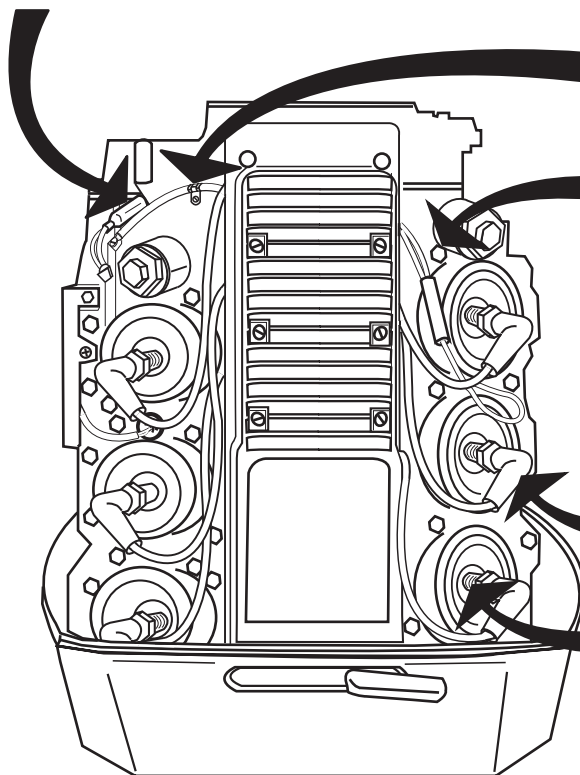

### Metal Clamps – Tie Straps

- Position as shown in manual

### Screws, Nuts, Washers

- Tighten firmly—these keep clamps in position and ends of wires from sparking
- Where lock washers are called for, use them

### Spark Plug Boots

- Not torn or cracked
- Fully pushed onto spark plug

### Spark Plugs

- Avoid rough handling that could crack ceramic part of plug. (Sparks may jump across outside of plug.)

In transom area:

### All Connections

- Clean
  - Tight
- (Prevents sparks)

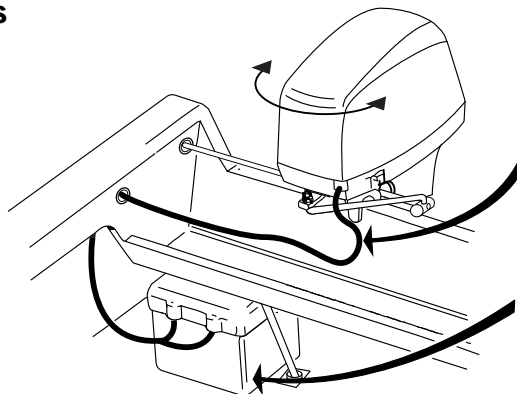

### Electric Cable

- Not rubbing on sharp objects
- Enough slack to allow full turning without pull loads on cable (prevents sparks)

### Batteries

- Secure in approved battery box or battery tray
- Battery terminals insulated
- No strain on cables

## SAFETY

After repair on any part of the fuel system, pressure test engine portion of fuel system as shown:

### When Storing:

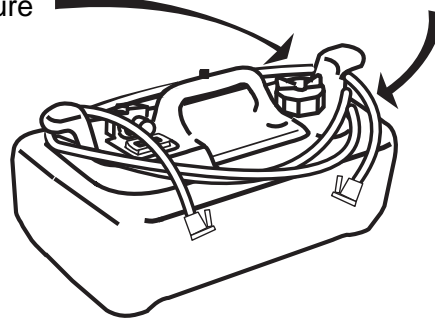
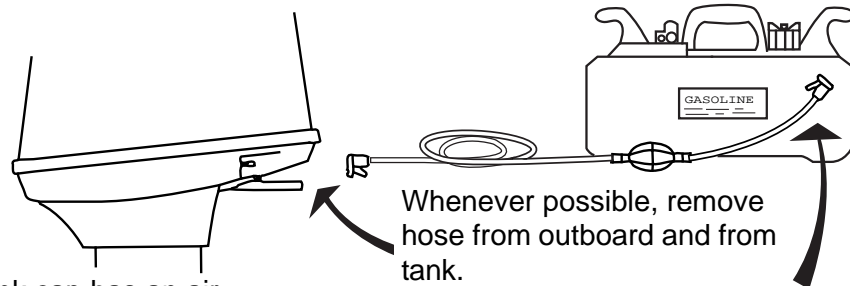
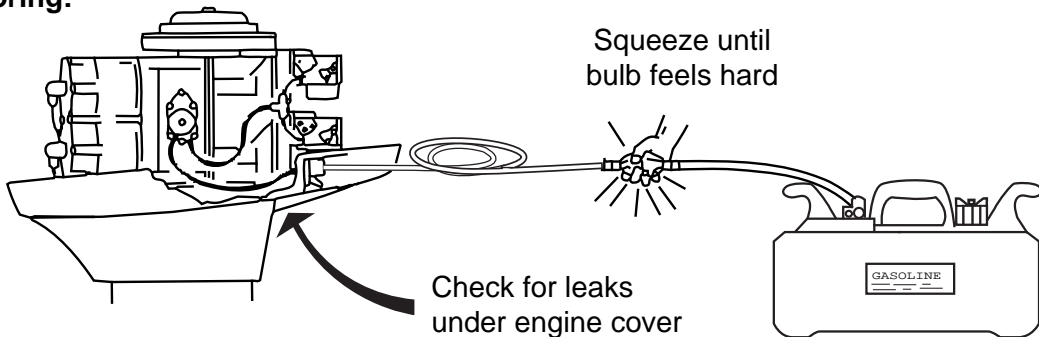

If gasoline tank is stored indoors, do not put it in a room having an appliance with a pilot light or where electrical appliances or switches (which may spark) will be used.

### When Running:

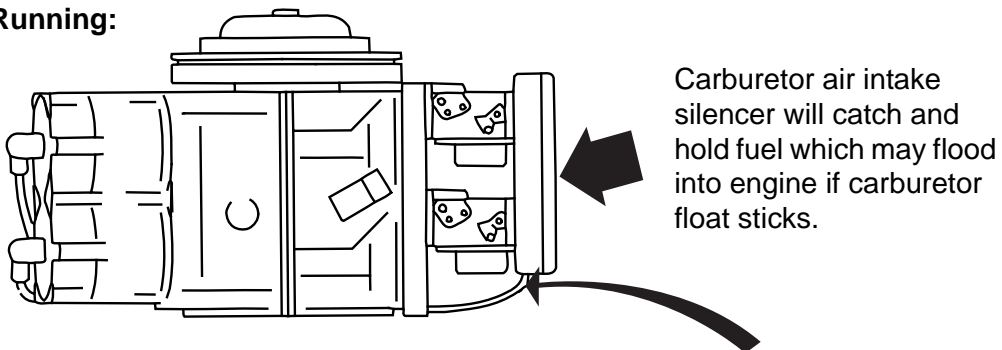

- Make sure silencer and its gaskets are on engine and drain hose is in place.
- Air silencer mounting screws are special lock screws. Use only the special screws.

## Outboard Mounting System and Safety

The mounting system includes:

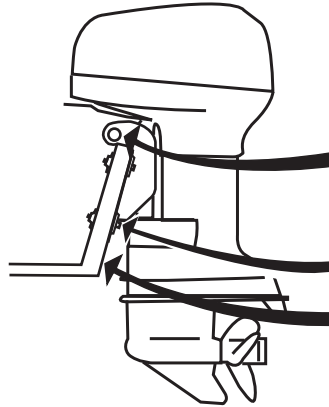

- outboard parts
- bolts, nuts, and washers
- boat's transom

### What is most important?

- Outboard must **stay** in position on boat's transom.

### What could happen?

Outboard may

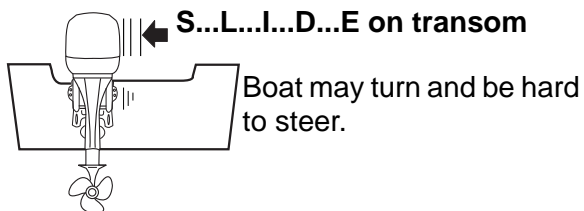

Outboard may

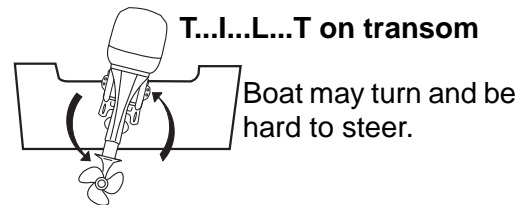

- If outboard hits something solid and does not stay on the transom, boat occupants may be injured from the outboard or its parts entering the boat.

Boat's transom could break away.

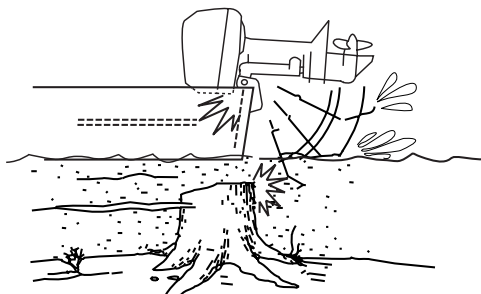

Outboard may be lost overboard.  
Boat may **SINK**.

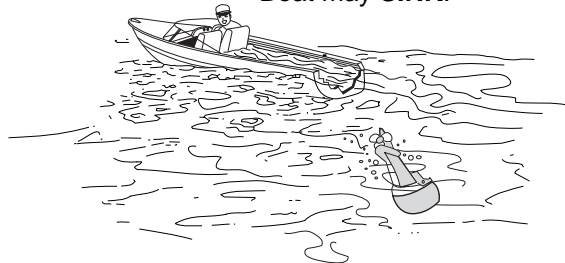

### How Can Loss of Mounting Be Minimized?

- **Read, understand, and follow** manufacturer's **instructions**.
- Follow warnings marked "⚠" closely.

# SAFETY

## If weakened, parts could fail later on the water, when not expected

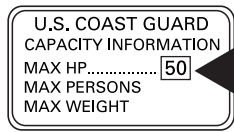

If boat plate shows...

Use only  
or smaller



When rigging or fixing any boat, if transom looks weak, tell the owner.

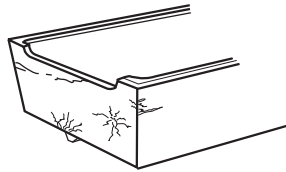

If transom is curved, outboard may come loose.

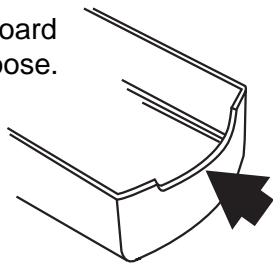

Mount on flat surface only.  
Use shims to make surface flat.

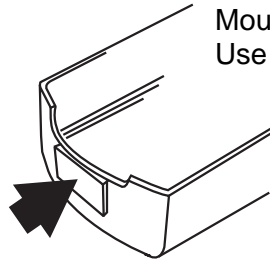

Use bolts, nuts, and washers supplied with outboard. They are usually special, and will not rust or weaken.



If owner tells you "I hit something really hard..."

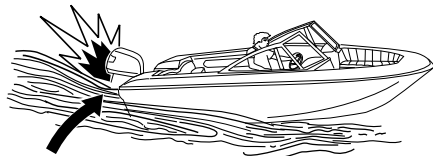

Check for a high speed blow to the lower unit.

OR...

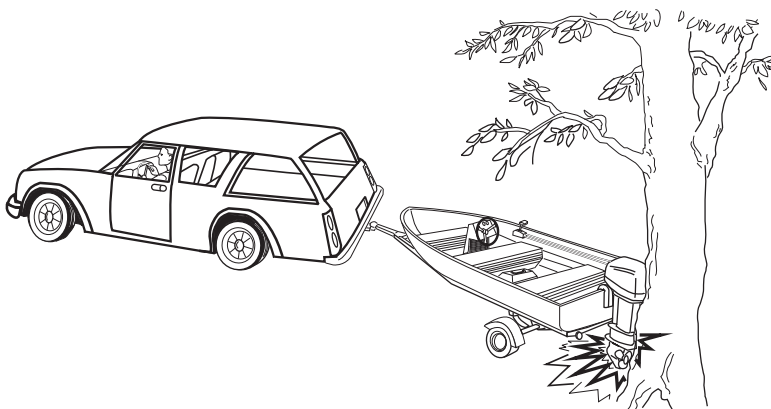

"I was backing up and I think the outboard may have hit a tree or something."

Check for a slow, heavy squash to the outboard.

- Look for damaged parts and loosened nuts and bolts in both the steering and mounting systems. Replace damaged parts.

## Outboard Hydraulic Tilt/Trim Shock Absorption System and Safety

### What is most important?

- Shock absorption system must always be ready to absorb some blows to the lower parts of the outboard.
- Outboard must not trim in too far suddenly.

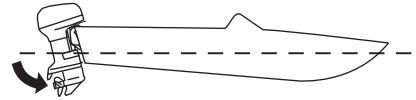

### What can happen?

Without shock protection, a blow like this could cause serious damage to the outboard and injury to boat occupants from the outboard or its parts entering the boat. Transom could break away and outboard may be lost overboard.

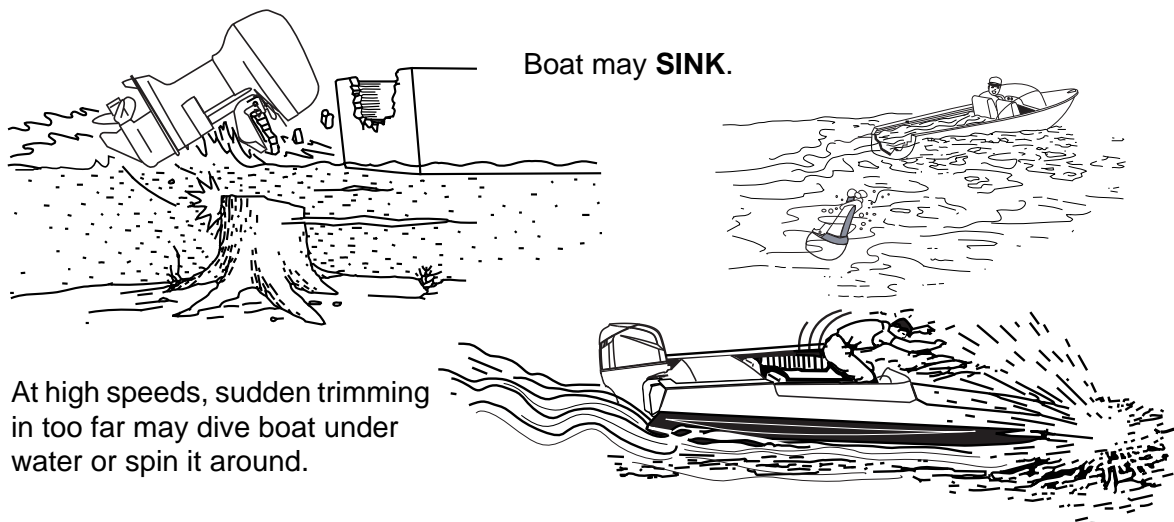

Boat may **SINK**.

At high speeds, sudden trimming in too far may dive boat under water or spin it around.

### How can possible conditions be minimized?

- **Read, understand, and follow** manufacturer's **instructions**.
- Follow warnings marked "⚠" closely.
- Test your work whenever possible.
- If oil leaks are seen in service areas, determine source. Keep reservoir filled.
- If outboard is hydraulic tilt/trim model, always return rod to hole position determined by boat operator and make sure angle adjusting rod retain is in locked position.

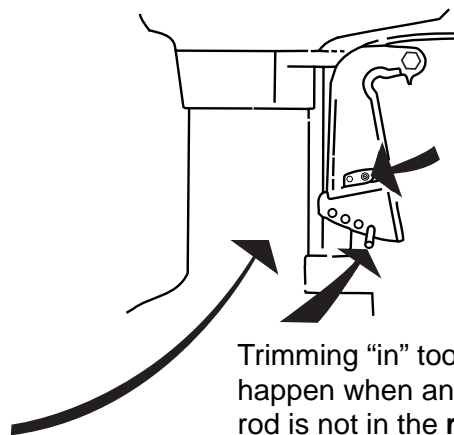

Make sure manual release valve is closed tight. Torque to 45 to 55 in. lbs. (5.1 to 6.2 N-m).

If left open, outboard has no shock protection.

Trimming "in" too far can happen when angle adjusting rod is not in the **right** hole or is not in **any** hole (lost).

## Outboard Emergency Stop System and Safety

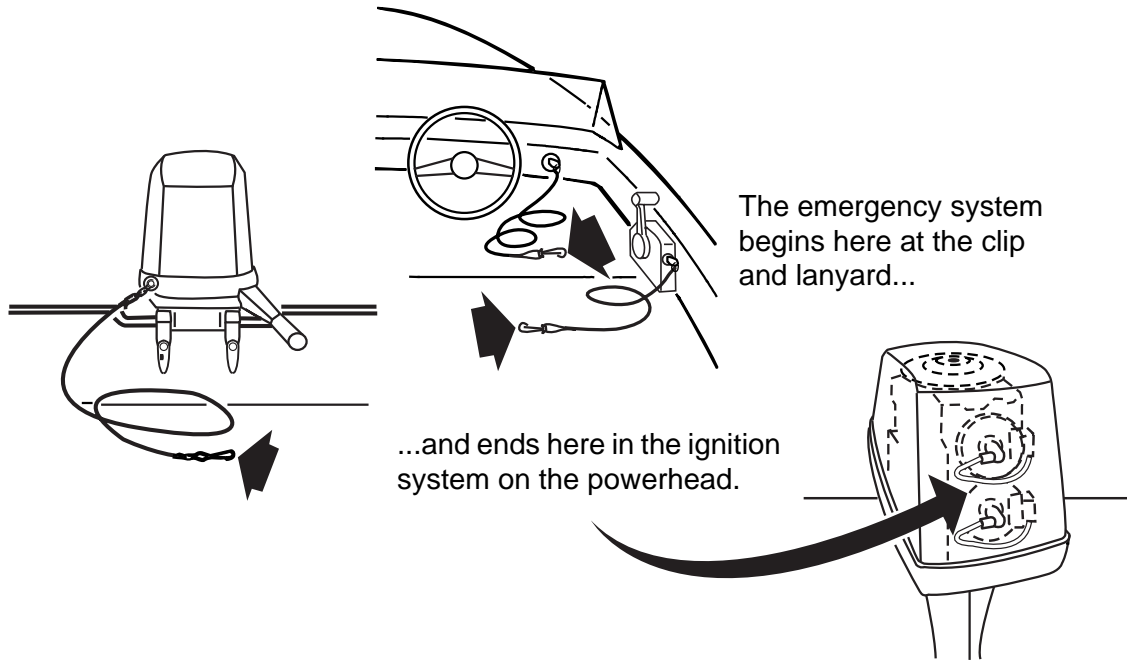

### What is most important?

- The emergency stop system must **STOP** the engine when the clip is removed or the lanyard pulled from the emergency stop / key switch.

### What could happen?

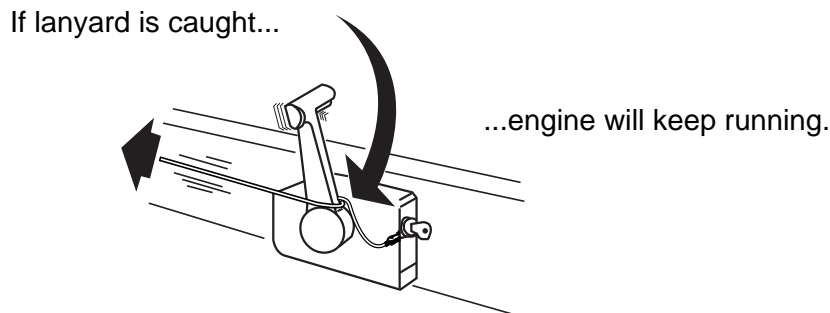
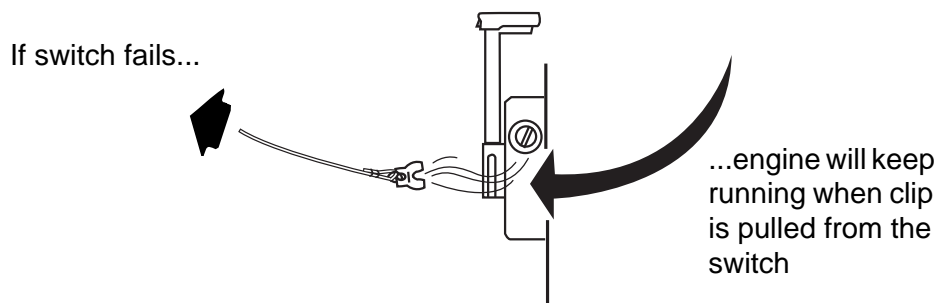



## What could happen?

If lanyard is cut or frayed...

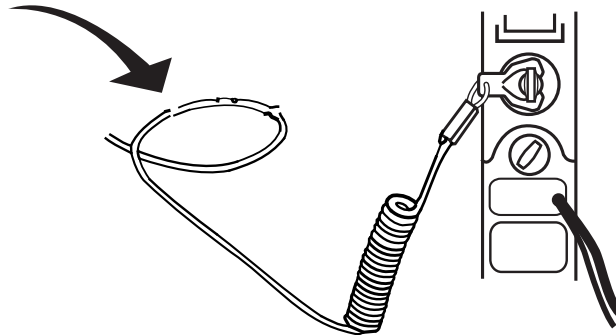

...lanyard or clip may break when pulled...

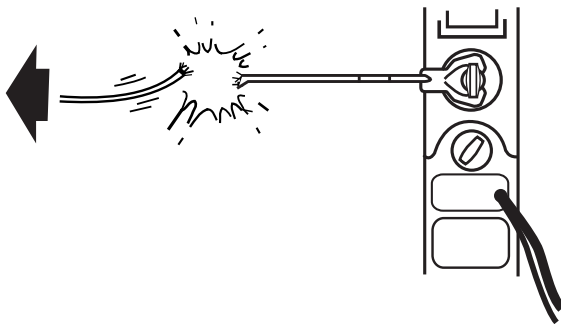

If engine does **NOT** stop when lanyard is pulled, an operator thrown from the boat could be hit as boat circles area. Or, boat may not turn but leave area as a runaway. Operator may drown and boat **WILL** run into something.

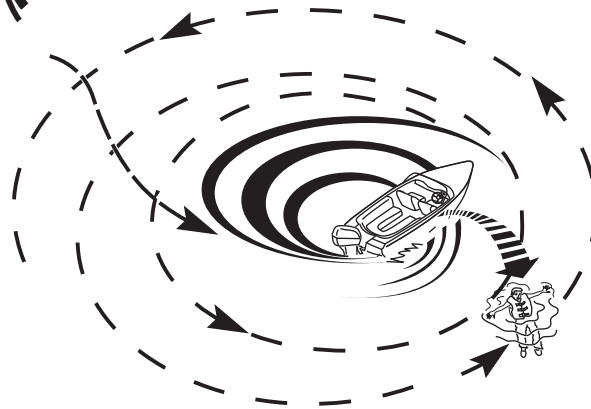

### How can failure of the emergency stop system be minimized?

- **Read, understand, and follow** manufacturer's instructions
  - Follow warnings marked "⚠" closely.
  - Assemble parts carefully.
  - Inspect lanyard for cuts or fraying; clip for wear. Replace with original parts. Do not substitute.
  - Locate control box and other items in area to keep lanyard from being caught.
  - **ALWAYS TEST EMERGENCY STOP SYSTEM. PULL LANYARD. ENGINE MUST STOP. IF IT DOES NOT, REPAIR BEFORE NEXT USE.**
- When rigging or after servicing**

## Summing up

Now you know some things that can take the joy out of boating.

### **No doubt about it—proper safety takes time!**

- Reading and understanding instructions
- Re-reading warnings marked “⚠”
- Putting parts together correctly
- Making correct adjustments
- Testing your work

### **And making sure**

- Worn or damaged parts are replaced
- Replaced parts are like originals in every way
- Customer is told of things which need attention

**But, do you really want the alternative?**

# MARINE PRODUCTS AND THE SAFETY OF PEOPLE WHO FIX THEM

The first part of this Safety section talked about safe boating and how you, the technician, can help keep it safe for the boater. But what about you? Technicians can be hurt while:

- Rigging boats
- Troubleshooting problems
- Fixing components
- Testing their work

Some of these safety issues you will know, others you may not.

## Handling Outboards

### When lifting outboards

Some outboards have a fixed lift bracket bolted to the powerhead. Because outboard will want to hang like this when off the floor...

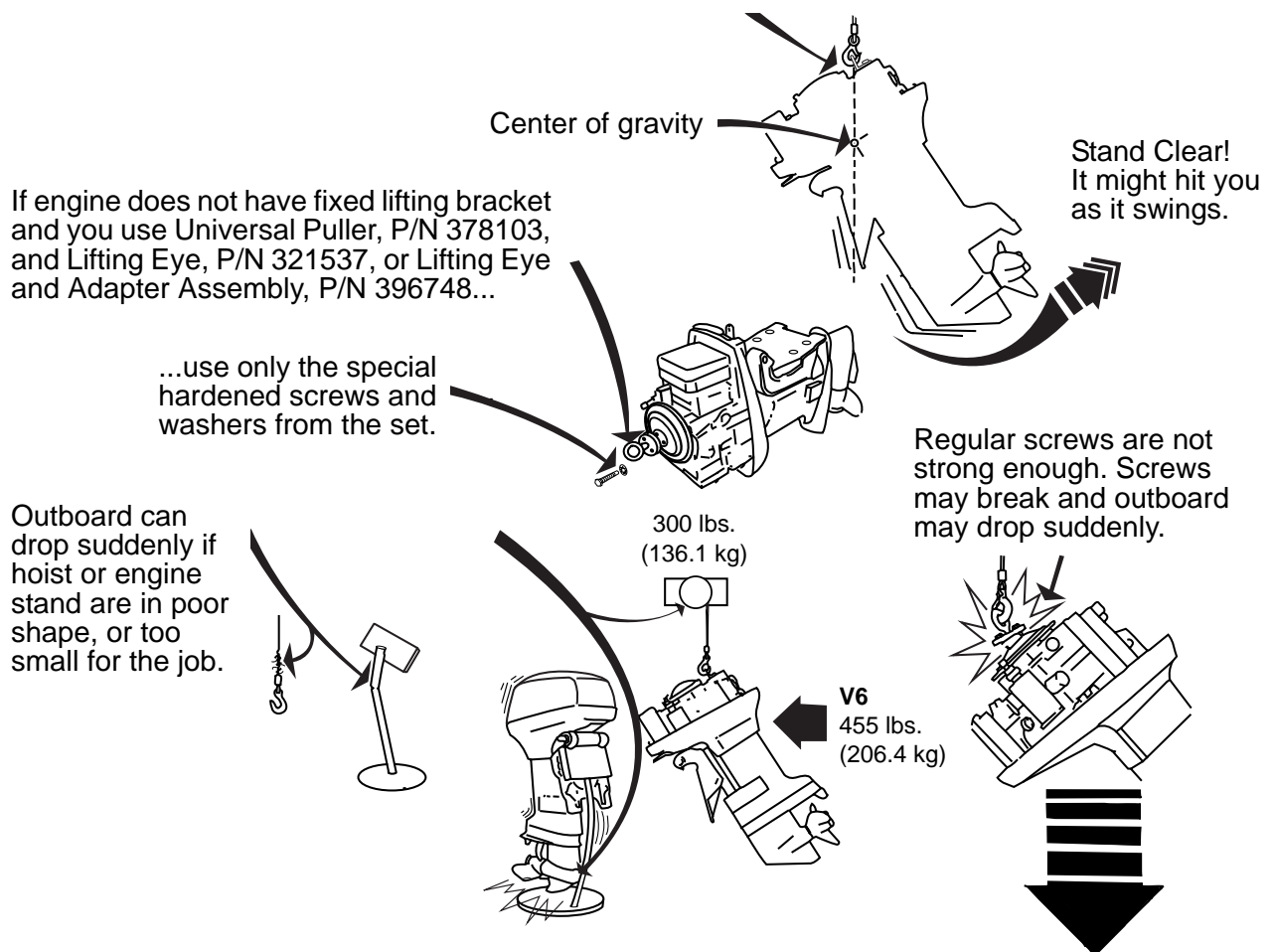

- Make sure shop aids have extra capacity, and keep them in good repair.

---

## SAFETY

---

### Running outboard with engine cover removed

Engine cover is a guard. When you remove cover/guard to work on the outboard, remember: loose clothing (open shirt sleeves, neckties), hair, jewelry (rings, watches, bracelets), hands and arms can be caught by the spinning flywheel.

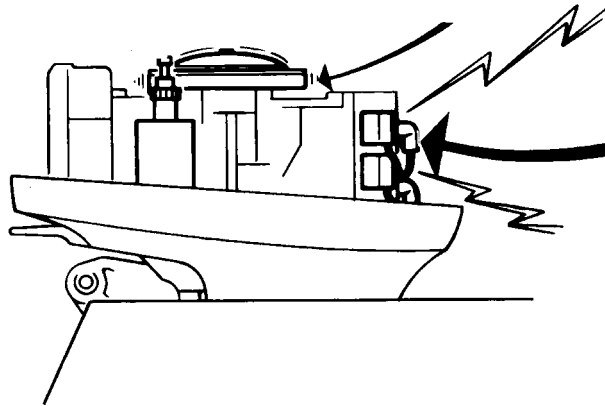

Handling high voltage parts like spark plugs and coils can shock you and may cause you to recoil into the rotating flywheel.

- Two people working together on a live outboard must look out for each other. Never, ever, use the key to start the outboard before signaling your partner. He may be leaning over the outboard with hands on the flywheel, handling a “hot” electrical part, or near the propeller.

### Outboard starting at the wrong time

When you do things that turn the flywheel like:

- Off-season storage fogging (oiling) of outboard;
- Removing propeller with a powered tool;
- Electrical system checks;
- Servicing the flywheel; or
- Any other actions **ALWAYS...**

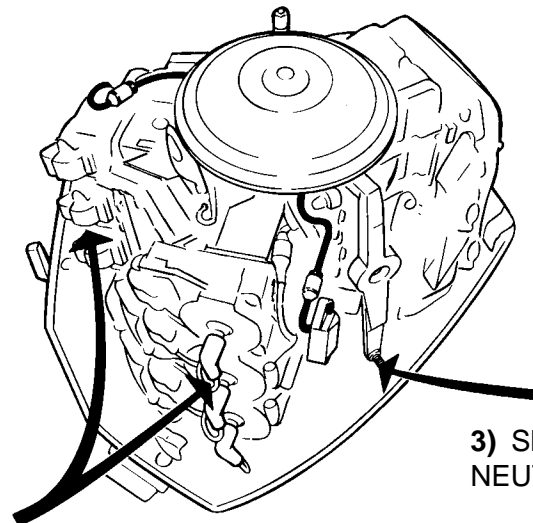

1) Turn key switch OFF

2) Twist and remove ALL spark plug leads

3) Shift to NEUTRAL

Check prop shaft. Is outboard really in NEUTRAL?

NO SPARK



NO START



NO SURPRISES

## Running outboard too fast (Overspeeding)

- “Too fast” means running faster than outboard normally runs on boat.

Running too fast can happen when:

### 1) Using a flushing device...

Turn on water before starting outboard. Keep engine speed below 2000 RPM. With no load, outboard will run too fast very easily. Wear eye protectors.

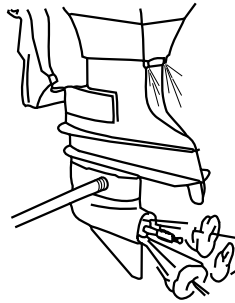

### 2) Running with the wrong test wheel...

This may happen if outboard runs too fast.

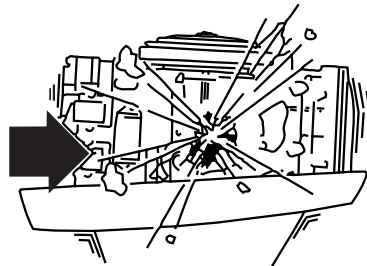

Use the right test wheel.

## Running outboards: Exhaust fumes

### DANGER

**DO NOT run the engine indoors or without adequate ventilation or permit exhaust fumes to accumulate in confined areas. Engine exhaust contains carbon monoxide which, if inhaled, can cause serious brain damage or death.**

- Whenever running the engine, assure there is proper ventilation to avoid the accumulation of carbon monoxide (CO), which is odorless, colorless, and tasteless, and can lead to unconsciousness, brain damage, or death if inhaled in sufficient concentrations. CO accumulation can occur while docked, anchored, or underway, and in many confined areas such as the boat cabin, cockpit, swim platform, and heads. It can be worsened or caused by weather, mooring and operating conditions, and other boats. Avoid exhaust fumes from the engine or other boats, provide proper ventilation, shut off the engine when not needed, and be aware of the risk of backdrafting and conditions that create CO accumulation. In high concentrations, CO can be fatal within minutes. Lower concentrations are just as lethal over long periods of time.

# SAFETY

## Running outboards: Propellers



### DANGER

Contact with a rotating propeller is likely to result in serious injury or death. Assure the engine and prop area is clear of people and objects before starting engine or operating boat. Do not allow anyone near a propeller, even when the engine is off. Blades can be sharp and the propeller can continue to turn even after the engine is off. Always shut off the engine when near people in the water.

### Eye protection

Eyes need protection when:

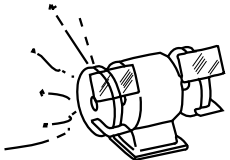
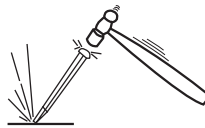
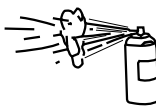
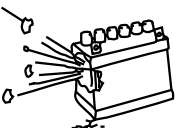

- Grinding 
- Chiseling   
Tip: When steel on steel, use plastic- or brass-type hammers. They don't chip off as easily as steel hammers.
- Spraying cleaners and paints 
- Acid 
- Ends of cables 

**Wear Safety Glasses** 

## Handling Lead/Acid Batteries

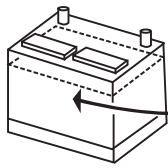

Strong acid solution  
(sulfuric acid)

If solution gets into eyes, wash  
and contact a doctor immediately.

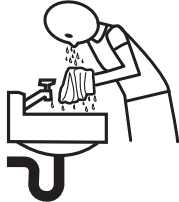

If spilled or  
splashed on any  
part of body...



Wash with  
lots of water.



## Charging lead acid batteries

- 1) Attach and remove these cables with charger UNPLUGGED from 110 V wall socket. (This prevents shocks if charger is defective.)
- 2) Observe correct polarity when connecting these larger leads.
- 3) Always charge in a well ventilated area. Charging causes acid solution to give off hydrogen gas through the vents in the caps. **Make sure vents are open.** If clogged, pressure inside may build. Battery may EXPLODE.

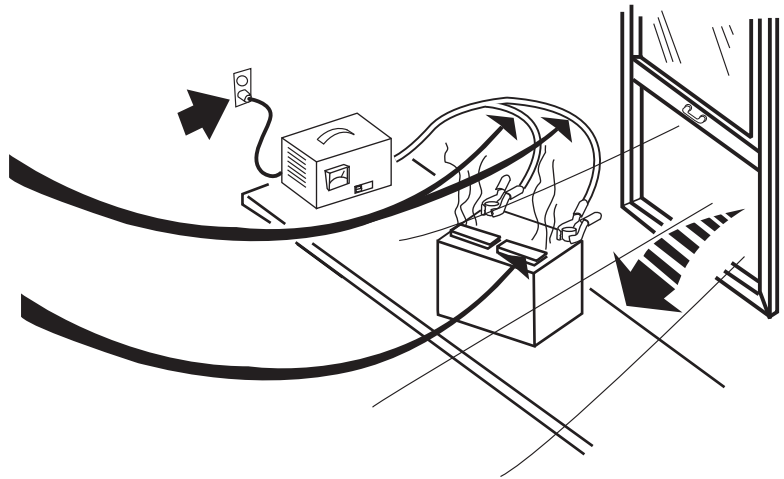

## Battery gas is explosive!

**While charging or discharging, remember:**

- No smoking
- No flames
- No sparks



Never remove charger cables from battery posts. It is a sure way to make a lot of sparks in an area surrounded by battery gas.

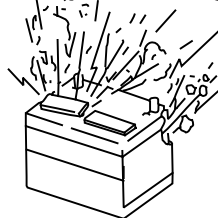

DO NOT check battery charge by placing metal objects across posts. You will make sparks and serious burns are possible.



**After charging:**

- Shut off charger
- Pull charger plug out of 110 V outlet
- Take charger cables off battery posts

## SAFETY

### Gasoline – Handle With Care!

Gasoline vapor and air mixtures explode easily and violently when mixed as shown...

When you smell ANY odor of gasoline, explosion is possible.

Gasoline fumes are heavy and will sink to the lowest point in the boat or room and will STAY there, WAITING...

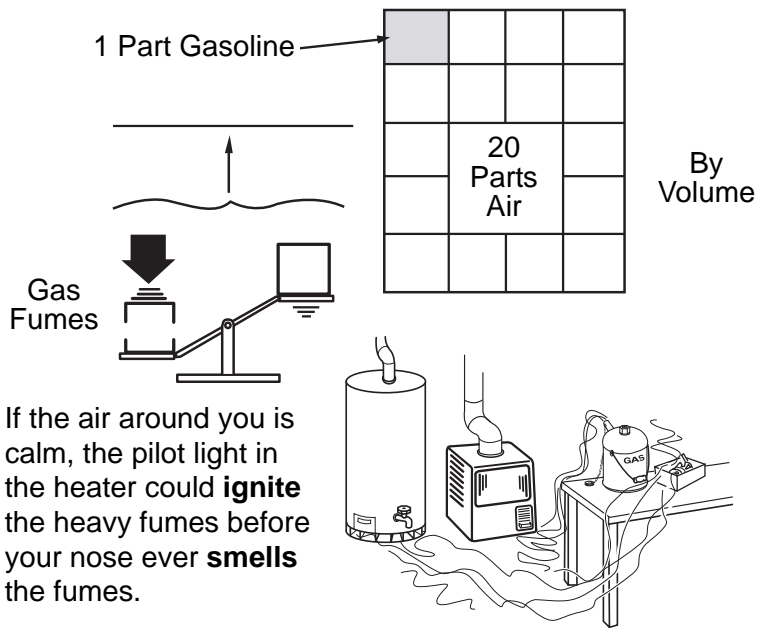

### What can you do?



Store gasoline in sturdy, approved, sealed gas can and keep outside.

- Always store gasoline outside in a safe can (flame arrester and pressure relief valve in pour spout).
- Fill portable tanks outside of boat. Spillage will collect in bottom of boat.
- Use fuel as fuel **ONLY**, **not** for a cleaner or degreaser.
- If fumes are smelled in shop, basement, or garage, **immediately**:
  - Put out open flames, cigarettes, sparking devices;
  - Wipe up spill or leak;
  - Get towels and rags outside fast;
  - Open doors and windows; and
  - Check **lowest** area for fumes.

Be aware of items in and around repair area which can ignite fumes. Control them if fumes are smelled.

- Matches, cigarettes, blow torches, welders
- Electric motors (with unsealed cases)
- Electric generators (with unsealed cases)
- Light switches
- Appliance pilot lights or electric ignitors (furnace, dryer, water heaters)
- Loose wires on running outboards
- Other variables which may ignite fumes

**How many of these are in your repair area?**



## Hazardous Products

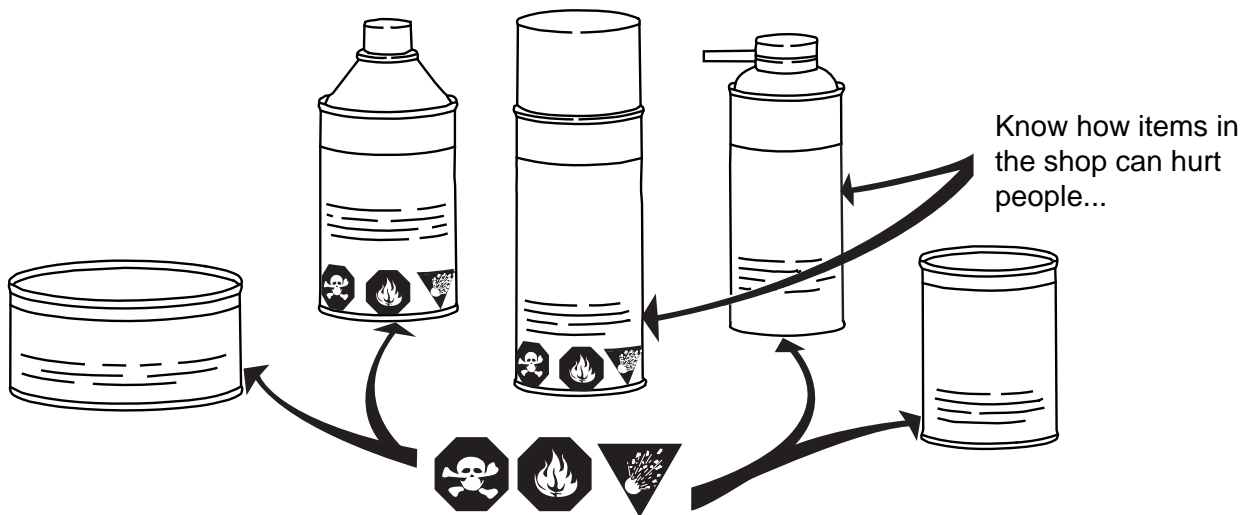

### READ

- “How and where to use”
- “How to give First Aid.” Have recommended First Aid materials on hand should an emergency arise
- “How to dispose of can”

It’s all on the **back of the can or bottle label**.

**And remember:** Little children are very curious and will try to taste everything so **keep containers away from children!**



## **Safety Awareness Test**

The Technician's Safety Awareness Test....

- 1) Did you read this Safety section from page S-1 to page S-24?
- 2) Are you ready to take responsibility for the safe maintenance practices and procedures of your repair shop, co-workers, and technicians?
- 3) Do you understand all the safety precautions and instructions contained in this entire service manual?
- 4) Will you follow all safety warnings, precautions, instructions and recommendations outlined in this service manual?
- 5) Do you understand that the service manual as a whole and this Safety section, in particular, contain essential information to help prevent personal injury and damage to equipment and your customers?
- 6) Have you received training related to common shop safety practices to protect yourself and others around you?
- 7) When replacement parts are required, will you use *Evinrude®/Johnson® Genuine Parts* or parts with equivalent characteristics, including type, strength and material?
- 8) Are you ready to follow the recommendations in this service manual before you service any boat or outboard?
- 9) Do you understand that safety-related accidents can be caused by carelessness, fatigue, overload, preoccupation, unfamiliarity of operator with the product, drugs and alcohol, just to name a few?

---

# INDEX

## A

### Abbreviations 6

### Accessories

*XD100* Outboard Oil Decal, P/N 352369  
149

### Adjustments

Control Cable 18, 240  
Neutral Switch 25  
Shift Linkage 189, 264  
Steering Friction 24  
Throttle Friction 24  
Tiller Handle Friction 25  
Tiller Handle Ratchet 25  
Tiller Height 25  
TPS Calibration 106  
Trim Sending Unit 26  
Trim Tab 27

### Air Silencer 37

### Air Temperature Sensor

Description 53  
Resistance Test 88

### Alternator Circuit Test 93

### AMP Connector Servicing 112

### Anodes

Anti-Corrosion 38  
Continuity Check 38  
Gearcase 253  
Stern Bracket 210

## B

### Batteries

Charging System Tests 91  
Connections 21  
Maintenance 21  
Requirements 11  
Storage 40

### Bearing

Crankshaft 175, 176, 177, 179, 180  
Driveshaft 256, 260  
Forward Gear 257, 259  
Pinion Gear 257, 260  
Propeller Shaft 258

### Break-In

*EMM* Programming 150, 190  
Gearcase 249, 266  
Oiling 150  
Procedure 62

## C

### Cable, Hose, and Wire Routing 18

### Clamp Screw Service 216

### Connecting Rods

Installation on Piston 181  
Removal from Crankshaft 174  
Removal from Piston 174

### Control Cable

Adjustments 18, 240  
Installation 18

### Cooling System

Components 159  
*EMM* and Vapor Separator Cooling 161  
Engine Temperature Check 162  
Exhaust Housing 159  
Flushing 30  
Hose Routing and Water Flow 158  
Operating Temperatures 11, 29  
Operation 161  
Pressure Relief Valve 160, 164  
Running on a hose 31  
Thermostat 11, 160, 164  
Vapor Separator 123  
Water Intake Screens 29  
Water Pump 159, 250

### Corrosion

Anodes 38, 210, 253  
Cylinder walls 177  
Long Term Storage 39  
Metal components 38  
Steering Cable 32

### Cover Service 44

### Crankcase

Assembly 183  
Disassembly 173

### Crankshaft

---

## INDEX

---

Assembly 179, 182  
Disassembly 174, 175

### **Crankshaft Position Sensor**

Description 55  
Operation Test 74  
Resistance Test 87

### **Cylinder Bore**

Honing 177  
Inspection 178

### **Cylinder Head**

Inspection 178  
Installation 184  
Removal 173

## **D**

### ***Deutsch* Connector Servicing 111**

### **Diagnostic Procedures**

Dynamic Tests 70  
Fuel Delivery Tests 78  
Ignition Tests 73  
LED Indicators 71  
Strategy 68

### **Diagnostic Software**

Break-In Programming 150  
Communication With Outboard 58  
Crankshaft Position Sensor 74  
Cylinder Drop Tests 70  
Diagnostic Procedures Overview 68  
Fuel Injector Programming 64, 133  
Fuel Injector Tests 78  
Fuel Pump Test 78  
Oil Injector Test 152  
Oil Priming 156  
Oiling Rate 62, 149  
Reports 64  
Sensor Monitoring 87  
Service Codes 60  
Static Ignition Test 75  
Timing Verification 63, 106  
TPS Calibration 63, 106

### **Driveshaft Bearing**

Installation 260  
Removal 256

### **Driveshaft Seals**

Installation 261  
Removal 256

## **E**

### **Electrical Circuits**

*EMM* Pin Locations 85  
Fuse 86  
Ground Circuits 86  
Key Switch 96  
Start Circuit 94  
*SystemCheck* 101

### **Electrical Connectors**

*AMP* Connectors 112  
*Deutsch* Connectors 111  
*Packard* Connectors 114

### **Electrical Harness**

Connections 20

### **Emergency Stop Switch**

Operation Check 28  
Test 99

### **Emissions Information 7**

#### ***EMM***

12 V Circuit Sensor 52  
Connections 50, 85  
Diagnostics 58, 68  
Functions 50, 56  
LED Indicators 71  
Sensors 52, 53  
Service Codes 60  
Servicing 66  
Software Replacement 65  
Timing Verification 106  
TPS Calibration 106  
Transfer 65

### **Engine Monitor**

Description 56  
Low Oil Warning 54, 147, 153  
No Oil Warning 147  
Operation Check 28

### **Engine Temperature Check 162**

### **Engine Temperature Sensor**

Description 54  
Resistance Test 88

### **Exhaust Housing**

Installation 203  
Removal 203

### **Exterior Finish Protection 38**

**F****Flushing, Cooling System** 30**Flywheel**

Installation 104

Removal 103

**Forward Bearing**

Installation 259

Removal 257

**Fuel Injectors**

Crush Ring Replacement 134

Electrical Circuits 119

*EMM* Programming 133, 135

Installation 135

Removal 133

Tests 127, 128

**Fuel System**

Additives 10, 121

Components 122

Filter 122, 131

Fuel Circulation Pump 123, 128

Fuel Filter 37

Fuel Lift Pump 122, 128, 132

Fuel Requirements 121

Hose Routing 118

Injector Servicing 64

Intake Manifold 138

Minimum Octane 10, 121

Pressure Tests 126

Priming 125

Relieving Pressure 130

Requirements 120

Troubleshooting 70, 78, 126

Vapor Separator 122, 132

**Fuse** 86**G****Gearcase**

Assembly 261

Bearings

Installation 258

Removal 256

Disassembly 253

Inspection 253

Installation 248

Leak Test 247

Lubricant 11, 34

Removal 248

Seal

Installation 258

Removal 256

Water Pump Service 250

**Grommet** 18**H****Honing** 177**Hoses**

Inspection 37

Oil Distribution 154, 155

Oil Recirculation System 148

Routing, Cooling System 158

Routing, Fuel System 118

**I****Idle Speed** 10, 56**Ignition**

Control Circuit Tests 77

Electrical Circuits 84

Ignition Coil Servicing 105

Ignition Coil Tests 77

Required Systems 73

Running Tests 76

Static Ignition Test 75

Timing 63

**Information Display Systems**

Tachometer Setting 28

**Intake Manifold**

Assembly 139

Disassembly 139

Inspection 139

Installation 140

Removal 138

**K****Key Switch**

Operation Check 28

Start Circuit 96

**L****LED Indicators** 71**Lower Cover**

Installation 45

Removal 45

---

## INDEX

---

### Lubrication

Engine Oil 10, 146  
Gearcase 11, 34  
Power Trim 11  
Propeller Shaft 33  
Swivel Bracket 32  
Throttle and Shift Linkage 33  
Tiller handle 32  
Tilt Tube 32  
Trailer Bracket 32  
Trim and Tilt 35

### M

#### Maintenance Schedule 14

#### Manual Starter

Assembly 286  
Installation 282  
Rope Replacement 283, 287

#### Models

Included Models 9  
Model Designation 8  
Serial Number Location 8

#### Motor Mounts

Lower Mount Servicing 205  
Upper Mount Servicing 205

#### Muffler

Servicing 206

### N

#### Neutral Switch Adjustment 25

#### New Engines

Outboard Rigging Procedure 17

### O

#### Oetiker Clamp Servicing 22

#### Oil Injector

Electrical Circuit (55 V) 147  
Electrical Tests 151  
Functional Test 153

#### Oiling Rate 62, 149

#### Oiling System

Components 146  
Electrical Circuits 145  
Engine Lubricant 10, 146  
Low Oil Switch 54  
New Engine Set-Up 146

Oil Distribution 143

Oil Distribution Hoses 143, 154, 155

Oil Filters 37

Oil Recirculation 148

Oil Tank 146, 155

Oiling Rate 62, 149

Priming 150

Servicing 154

Tests 151

#### Outboard Excessive Smoking T-5

#### Outboard Hard to Start T-3

#### Outboard Starts and Stalls T-4

#### Outboard Starts, Low Maximum RPM T-5

#### Outboard Surges, Runs Rough T-6

#### Outboard Will Not Start T-1

#### Outboard Won't Shut Off T-4

### P

#### Packard Connector Servicing 114

#### Pinion Bearing

Installation 260

Removal 257

#### Piston Rings

End Gap 179, 182

Installation 182

Removal 174

#### Pistons

Assembly 181

Inspection 179

Installation 182

Removal 174

#### Powerhead

Assembly 179

Cleaning 177

Cylinder Compression Testing 170

Disassembly 172

Inspection 178

Installation 188

Removal 170

#### Predelivery Checks 28

#### Pre-Season Service 40

#### Pressure Relief Valve

Assembly 165

Disassembly 164

Inspection 165

#### Priming

- Fuel System 125
- Propeller**
  - Inspection 245
  - Installation 246
  - Selection 245
- Propeller Shaft**
  - Installation 261
  - Lubrication 33
  - Removal 255
- Propeller Shaft Bearing Housing**
  - Bearing Installation 258
  - Installation 264
  - Removal 254
  - Seal Installation 259
  - Seal Removal 258
- R**
- Relays**
  - Trim and Tilt 100, 271
- Remote Controls**
  - Cable Adjustment 18
- Rigging**
  - Outboard 17
- RPM Limit** 11, 55, 56
- S**
- S.A.F.E.**
  - Description 57
  - Low Oil 54
  - No Oil 147
  - Temperature 52, 54
- Safety** 1
- Sensor Tests** 87
- Sensors**
  - Air Temperature Sensor 53, 88
  - Barometric Pressure Sensor 53
  - Crankshaft Position Sensor 55, 74, 87
  - EMM* 52
  - Engine Temperature Sensor 54, 88, 164
  - Throttle Position Sensor 55, 87
- Service Charts**
  - Electrical and Ignition 82
  - Fuel System 116
  - Gearcase 244
  - Midsection 198
  - Oiling System 142
  - Powerhead 168
- Shift Cable Adjustment, Tiller** 240
- Shift Linkage**
  - Adjustment 189
  - Installation 186
  - Lubrication 33
  - Removal 173
- Shift Rod Bushing**
  - Installation 259
  - Removal 257
- Shift Rod Connector** 171, 248, 249
- Shift Rod O-ring**
  - Installation 259
  - Removal 257
- Shifter**
  - Installation 261
  - Removal 255
- Shutdown** 58
  - No Oil 147
- Spark Plugs**
  - Gap 11, 36
  - Indexing 36
  - Maintenance Schedule 14
  - Recommendation 11, 36
  - Replacement 36
  - Service 36
- Specifications** 10
- Starter**
  - Assembly 109, 286
  - Circuit Description 94
  - Cleaning and Inspection 108
  - Current Draw Test 97
  - Disassembly 107
  - Installation 111, 282
  - Removal 107
  - Rope Replacement 283, 287
  - Solenoid Test 96
  - Voltage Drop Test 97
- Start-In-Gear Protection** 28
- Stator**
  - Resistance Test 89
  - Service 104
  - Voltage Output Test 89
- Steering Handle**
  - Assembly 232
  - Disassembly 228

---

## INDEX

---

Inspection 232

Installation 239

Removal 227

### **Steering System**

Lubrication 32

Steering Arm and Shaft 208, 217

Steering Friction 24

Steering Torque 27

### **Stern Bracket**

Assembly 210, 221

Disassembly 208, 216

Removal 218

### **Stop Circuit** 99

### **Storage** 39

### **Submerged Engines** 41

### **Swivel Bracket**

Lubrication 32

### **SystemCheck**

Circuits 101

LOW OIL Warning Signal 147

NO OIL Warning Signal 147

Outboard connections 20

Tests 101, 102

## **T**

### **Tachometer**

Pulse Setting 28

### **Technical Data** 10

### **Temperature**

Operating 29, 162

Operation below freezing 146

Sensors 53, 54

### **Temperature Sender**

Service 164

### **Thermostat**

Assembly 165

Description 160

Disassembly 164

Inspection 165

Temperature 11

### **Throttle Cable Adjustment, Tiller** 241

### **Throttle Linkage**

Installation 187

Lubrication 33

Removal 173

### **Throttle Position Sensor**

Description 55

Resistance Test 87

### **Tiller handle**

Lubrication 32

### **Tilt Support** 269

### **Tilt Tube**

Lubrication 32

### **Timing Adjustments**

Timing Pointer 106

Timing Verification 106

TPS Calibration 106

### **Tools**

Accessory Power Cable Kit, P/N 5008092  
59

Ball Socket Installer tool, P/N 342225 241

Ball Socket Remover Tool, P/N 342226  
138, 227

Bearing Cup Installer, P/N 319929 259

Bearing Installer, P/N 321428 – 25/30 258

Bearing Installer, P/N 322923 – 25/30 260

Bearing Installer, P/N 335820 – 25/30 258

Bearing Puller, P/N 432130 257

Bootstrap Tool, P/N 586551 65

Connector Service Tool, P/N 342667 111

Crankshaft Bearing/Sleeve Installer, P/N  
339749 179

Crimp Tool, AMP, P/N 777281 113

Crimping Pliers, P/N 322696 112

Diagnostic Interface Cable, P/N 437955 58

Diagnostic Power Supply, P/N 587005 59,  
74

Drive Handle, P/N 311880 259

Electrical Test Probe Kit, P/N 342677 93

Flywheel Holder, P/N 771311 104

Fuel Pressure Gauge, P/N 5007100 126

Gearcase Filler, P/N 501882 34

Gearcase Pressure Tester, P/N 507977  
247

Gearcase Vacuum Tester, P/N 507982 247

Guide Pin, P/N 383175 265

Lifting Eye, P/N 321537 171

Lifting Tool, P/N 354717 15

Oetiker Pincers, P/N 787145 23

Peak Reading Voltmeter, P/N 507972 90

Plate, P/N 318122 – 25/30 260

Plug, P/N 315391 127



- Primary Lock Tool, P/N 777077 112  
 Puller Bridge, P/N 432127 256, 258  
 Retaining Ring Pliers, P/N 331045 254, 264  
 Seal Installer, P/N 326552 – 25/30 261  
 Seal Installer, P/N 335821 – 25/30 259  
 Seal Installer, P/N 350958 212, 225  
 Secondary Lock Installer, P/N 777079 113  
 Secondary Lock Tool, P/N 777078 112  
 Shift Detent Sleeve, P/N 328081 263  
 Shift Rod Bushing Installer, P/N 304515  
     259  
 Shift Rod Bushing Remover, P/N 327693  
     257  
 Slide Hammer Adapter, P/N 340624 274  
 Slide Hammer Adaptor Kit, P/N 390898 134  
 Slide Hammer, P/N 391008 134, 180, 257,  
     274  
 Slide Hammer, P/N 432128 176, 257  
 Small Puller Jaws, P/N 432131 256, 258  
 Starter Winder/Installer Kit, P/N 342682  
     286  
 Stator Test Adaptor, P/N 354719 89, 90  
 Syringe, P/N 346936 153  
 Temperature Gun, P/N 772018 162, 163  
 Thermal Joint Compound, P/N 322170 163  
*Twist-Grip* Remover, P/N 390767 230  
 Universal Pinion Bearing Remover and In-  
     staller, P/N 5005927 257, 260  
 Universal Puller Set, P/N 378103 104, 171,  
     254  
 Wrench, P/N 334359 257  
 Wrist Pin Pressing Tool, P/N 326356 175  
 Wrist Pin Retainer Installation Tool, P/N  
     354720 181
- Torque Charts**  
   see Service Charts  
   Standard 12
- TPS Calibration** 106
- Trailing Bracket** 269  
   Lubrication 32
- Trim and Tilt**  
   Assembly 276  
   Disassembly 275  
   Inspection 270  
   Installation 274  
   Lubrication 35
- Removal 273  
   Reservoir Fluid 11, 270  
   Troubleshooting 270, 271
- Trim Gauge Test** 272
- Trim Sender**  
   Adjustment 26  
   Test 273
- Trim Tab**  
   Adjustment 27  
   Removal 247
- Troubleshooting**  
   Charging System Tests 91  
   Cylinder Drop Tests 70  
   Diagnostic Procedures 68  
   Fuel Control Adjustment 70  
   Fuel System 78, 126  
   Ignition 73, 76  
   Oiling System 151  
   Sensors 87  
   Stator Resistance Test 89  
   Strategy 69  
   Trim and Tilt 270, 271
- V**
- Vapor Separator**  
   Description 122  
   Installation 136  
   Removal 132
- Voltage Drop Test** 97
- W**
- Water Intake Screens** 29  
   Inspection 29  
   Installation 249
- Water Pump**  
   Assembly 250  
   Description 159  
   Disassembly 250  
   Inspection 250
- Winterizing** 39
- Wrist Pin**  
   Installation 181  
   Removal 174

---

# INDEX

---

# TROUBLE CHECK CHART

## OUTBOARD WILL NOT START

OBSERVATION	POSSIBLE CAUSE	PROCEDURE
Outboard does not turn over	Battery switch not ON	Check battery switch operation
	Discharged battery	Check battery, recharge or replace
	Battery cables and connections	Clean and tighten connections. Check for voltage drop in starter circuit.
	Faulty connection or ground, damaged electrical harness	Check all grounds, connections and wiring
	Fuse (10 A)	Check wiring, then replace faulty fuse
	Wiring harness	Check for 12 V at terminal "B" of key switch
	Key switch	Check key switch operation
	Starter solenoid	Check wiring and test solenoid
	Starter or bendix/drive gears	Check starter, inspect bendix/drive gears
	Seized powerhead or gearcase	Check and repair as needed
Outboard turns slowly	Discharged battery	Check battery, recharge or replace
	Battery cables and connections	Clean and tighten connections. Check voltage drop in starter circuit.
	Powerhead hydro-locked	Check cylinders for water
	Partially seized powerhead or gearcase	Check and repair as needed
	Starter or bendix/drive gears	Check starter, inspect bendix/drive gears

**TROUBLE CHECK CHART**  
**OUTBOARD WILL NOT START**

**OUTBOARD WILL NOT START**

OBSERVATION	POSSIBLE CAUSE	PROCEDURE
Outboard turns over	Stop circuit grounded	Check wiring and emergency stop switch. Check the safety lanyard is installed and stop circuit is not grounded.
	In gear—Tiller models	Make sure outboard is in neutral
	No Fuel	Check for fuel in fuel tank
	Water in fuel	Check fuel filter, sample fuel from fuel return manifold.
	Contaminated or poor fuel quality	Check or replace fuel supply
	Fuel supply restricted	Check primer, anti-siphon valve, and fuel pick-up. Use primer to fill vapor separator with fuel.
	Air in fuel system	Check for air in fuel supply manifold, refer to <b>FUEL SYSTEM</b> (vapor separator venting and fuel supply)
	Low or no fuel pressure to injectors	Check fuel manifold pressure, refer to <b>FUEL SYSTEM</b>
	Incorrect, fouled, or worn spark plugs	Replace spark plugs
	Fuel injectors not working	Check voltage at injectors
	Excessive fuel or oil, engine flooded	Check for leaking injectors, leaking fuel or oil lift pump, or leaking vapor separator vent, refer to <b>FUEL SYSTEM</b>
	Low or no 55 V alternator output	Check voltage on 55 V circuit, refer to <b>SYSTEM ANALYSIS</b> and <b>ELECTRICAL AND IGNITION</b>
	Capacitor or 55 V circuit wiring	Check capacitor and 55 V circuits, refer to <b>SYSTEM ANALYSIS</b> and <b>ELECTRICAL AND IGNITION</b>
	Ignition	Check ignition, refer to <b>SYSTEM ANALYSIS</b> and <b>ELECTRICAL AND IGNITION</b>
	CPS input to <i>EMM</i> , no sync	Check RPM reading while cranking
	No ignition system control signal from <i>EMM</i> to ignition coils	Check cranking RPM (300 minimum), refer to <b>SYSTEM ANALYSIS</b>
	Low or no compression	Check compression
	Water in engine	Check condition of spark plugs and cylinders
	Internal powerhead damage	Check and repair as needed
	Leaking cylinder/crankcase, intake manifold, or reed valves	Check and repair as needed
<i>EMM</i> program, timing, or operation	Check <i>EMM</i> program and timing; check injector information (by location and serial number)	
Neutral switch, tiller models	Check neutral switch operation	

## OUTBOARD HARD TO START

OBSERVATION	POSSIBLE CAUSE	PROCEDURE
Outboard eventually starts, may or may not run properly once started	Weak battery	Check battery, recharge or replace
	Battery cables and connections	Clean and tighten connections, check voltage drop on high amperage circuit
	Starter or bendix/drive gears	Check starter, inspect bendix/drive gears
	Water in fuel system	Check water separator/fuel filter, sample fuel from fuel return manifold test port
	Contaminated or poor fuel quality	Check or replace fuel supply
	Air in fuel system	Check for air in fuel supply manifold, refer to <b>FUEL SYSTEM</b> (vapor separator venting and fuel supply)
	Incorrect, fouled, or worn spark plugs	Replace spark plugs
	Low fuel pressure	Check pressure, refer to <b>FUEL SYSTEM</b>
	Fuel supply restricted	Check primer bulb, anti-siphon valve, and fuel pick-up, check for fuel system air leaks
	Low or no alternator output (55 V)	Check voltage on 55 V circuit, refer to <b>SYSTEM ANALYSIS</b> and <b>ELECTRICAL AND IGNITION</b>
	Capacitor or 55 V circuit wiring	Check capacitor and 55 V circuit (white/red), refer to <b>SYSTEM ANALYSIS</b> and <b>ELECTRICAL AND IGNITION</b>
	Restricted or leaking fuel injector(s)	Check injectors, refer to <b>FUEL SYSTEM</b>
	Weak or erratic ignition operation	Check ignition, refer to <b>SYSTEM ANALYSIS</b> and <b>ELECTRICAL AND IGNITION</b>
	Crankshaft Position Sensor (CPS)	Check CPS air gap and <i>EMM</i> LED indicators
	Excessive fuel or oil, engine flooding	Check for leaking injectors, leaking fuel or oil lift pump, or leaking vapor separator vent. Refer to <b>SYSTEM ANALYSIS</b> .
	<i>EMM</i> program, timing, or operation	Check <i>EMM</i> program and timing; check injector coefficients; and monitor injector circuits and ignition primary outputs
Internal powerhead damage	Check and repair as needed	
Leaking cylinder/crankcase, intake manifold, or reed valves	Check and repair as needed	

**TROUBLE CHECK CHART**  
**OUTBOARD WILL NOT SHUT OFF**

**OUTBOARD WILL NOT SHUT OFF**

OBSERVATION	POSSIBLE CAUSE	PROCEDURE
Outboard starts and runs, normal performance while running	Key switch or wire harness ground	Check key switch and ground to key switch, refer to <b>SYSTEM ANALYSIS</b> and <b>ELECTRICAL AND IGNITION</b>
	Stop circuit wiring	Check <i>EMM</i> LED indicators. Check wire harness (black/yellow) and key/stop switch(s).
	<i>EMM</i> failure	Check <i>EMM</i> LED indicators and eliminate stop circuit as possible cause. Stop wire (black/yellow) has 4.0 VDC from <i>EMM</i> with key on or outboard running.

**OUTBOARD STARTS AND STALLS**

OBSERVATION	POSSIBLE CAUSE	PROCEDURE
Outboard may not run for more than a few seconds	Faulty wiring, connections, or grounds	Check all grounds, connections, and wiring
	Incorrect, fouled, or worn spark plugs	Replace spark plugs
	Low or no alternator output (55 V)	Check voltage on 55 V circuits, refer to <b>SYSTEM ANALYSIS</b> and <b>ELECTRICAL AND IGNITION</b>
	Capacitor or 55 V circuit wiring	Check capacitor and 55 V circuit, refer to <b>SYSTEM ANALYSIS</b> and <b>ELECTRICAL AND IGNITION</b>
	Contaminated or poor fuel quality	Check or replace fuel supply
	Low fuel pressure	Check pressure, refer to <b>FUEL SYSTEM</b>
	Air in fuel system	Check for air in fuel supply manifold, refer to <b>FUEL SYSTEM</b> (vapor separator venting and fuel supply)
	Fuel supply restricted	Check primer bulb, anti-siphon valve, and fuel pick-up, check for fuel system air leaks
	Injector electrical circuit or control function	Check voltage at injectors, refer to <b>SYSTEM ANALYSIS</b>
	Restricted or leaking fuel injector(s)	Check injectors, refer to <b>FUEL SYSTEM</b>
	<i>EMM</i> program, timing, or operation	Check <i>EMM</i> program and timing; check injector coefficients; and monitor injector control wires and ignition primary outputs
	Weak or erratic ignition output	Check ignition, refer to <b>SYSTEM ANALYSIS</b> and <b>ELECTRICAL AND IGNITION</b>
	Internal powerhead damage	Check and repair as needed

## OUTBOARD STARTS, LOW MAXIMUM RPM

OBSERVATION	POSSIBLE CAUSE	PROCEDURE
<i>SystemCheck</i> light	Outboard is in <i>S.A.F.E.</i>	Check Service Codes and <i>SystemCheck</i> warning
Setup or rigging change	Incorrect propeller	Refer to specifications, check recommended WOT RPM; water test and install correct pitch propeller
	Incorrect outboard mounting height	Refer to installation guidelines
Performance of outboard at lower speeds appears normal	Incorrect, fouled, or worn spark plugs	Replace spark plugs
	Contaminated or poor quality fuel	Check or replace fuel supply
	Fuel supply restricted	Check primer bulb, anti-siphon valve, and fuel pick-up, check for fuel system air leaks
	Low alternator output (55 V)	Check voltage on 55 V circuits, refer to <b>SYSTEM ANALYSIS</b> and <b>ELECTRICAL AND IGNITION</b>
	Weak or erratic ignition operation	Check ignition, refer to <b>SYSTEM ANALYSIS</b> and <b>ELECTRICAL AND IGNITION</b>
	Fuel injector electrical circuit or control function	Check voltage at injectors, refer to <b>SYSTEM ANALYSIS</b>
	Restricted or leaking fuel injectors	Check injectors, refer to <b>FUEL SYSTEM</b>
	Low fuel pressure	Check circulation pump operation, refer to <b>FUEL SYSTEM</b>
	<i>EMM</i> programming, timing, or operation	Check <i>EMM</i> program and timing; check injector coefficients; and monitor injector circuits and ignition primary outputs
	Restricted engine exhaust	Check and repair as needed

## EXCESSIVE SMOKING

OBSERVATION	POSSIBLE CAUSE	PROCEDURE
May coincide with increased oil consumption (normal if occurs after winterization)	Contaminated or poor fuel quality	Check or replace fuel supply
	Excessive fuel or oil consumption	Check fuel system for fuel supply air leaks or leaking fuel injectors
	Outboard in break-in mode	Use diagnostics program to check
	Outboard mounted too low	Check installation height of outboard
	Vapor separator vent	Check vapor separator assembly for proper venting/float valve operation
	Faulty/leaking fuel injector(s)	Check injectors, refer to <b>FUEL SYSTEM</b>
	Damaged fuel lift pump	Check for internal leaks

**TROUBLE CHECK CHART**  
**OUTBOARD SURGES, RUNS ROUGH**

**OUTBOARD SURGES, RUNS ROUGH**



OBSERVATION	POSSIBLE CAUSE	PROCEDURE
1200 RPM and above	<i>S.A.F.E.</i>	Access <i>EMM</i> fault codes
May be erratic or inconsistent	Incorrect, fouled, or worn spark plugs	Replace spark plugs
	Water in fuel system	Check water separator/fuel filter, sample fuel from fuel return manifold test port
	Contaminated or poor fuel quality	Check and replace fuel supply
	Low or erratic fuel pressure	Check pressure, refer to <b>FUEL SYSTEM</b>
	Air in fuel system	Check for air in fuel supply manifold, refer to <b>FUEL SYSTEM</b> (vapor separator venting and fuel supply)
	Fuel supply restricted	Check primer bulb, anti-siphon valve, and fuel pick-up, check for fuel system air leaks
	Restricted or leaking fuel injector(s)	Check injectors, refer to <b>FUEL SYSTEM</b>
	Faulty wiring, connections, grounds, or CPS air gap	Check all grounds, connections, and wiring. Check CPS air gap.
	Low alternator output (55 V)	Check voltage on 55 V circuit, refer to <b>SYSTEM ANALYSIS</b> and <b>ELECTRICAL AND IGNITION</b>
	<i>EMM</i> program, timing, or operation	Check <i>EMM</i> program and timing; check injector coefficients; and monitor injector circuits and ignition primary outputs
	Weak or erratic ignition operation	Check ignition, refer to <b>SYSTEM ANALYSIS</b> and <b>ELECTRICAL AND IGNITION</b>
	Capacitor or 55 V circuit wiring	Check capacitor and 55 V circuit (white/red), refer to <b>SYSTEM ANALYSIS</b> and <b>ELECTRICAL AND IGNITION</b>
Audible noise	Restricted engine exhaust	Check and repair as needed
	Internal powerhead damage	Check and repair as needed
	Damaged gearcase	Inspect gearcase and lubricate

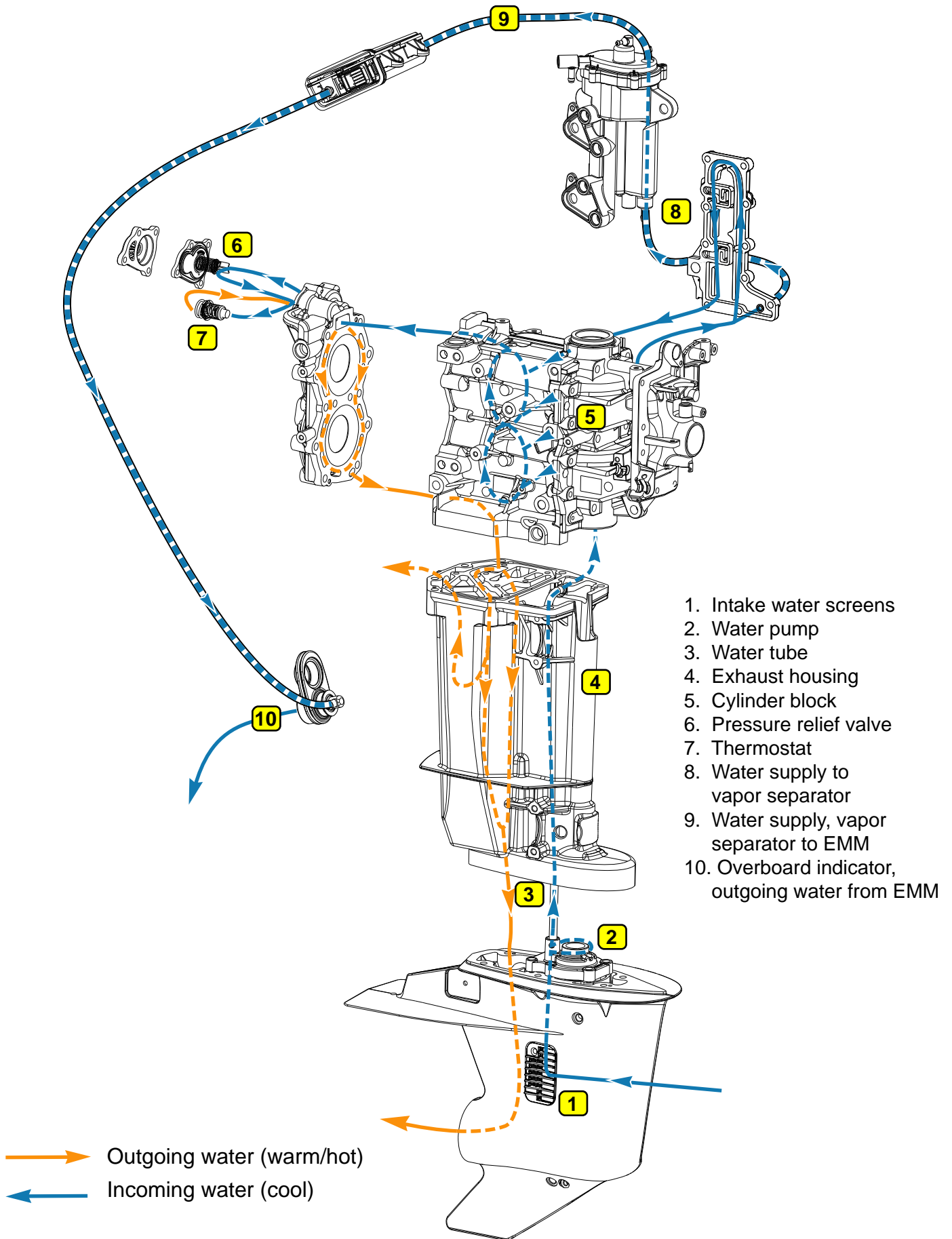

# Hose Routing and Water Flow Diagram 15 – 30 HP E-TEC Inline 2 Cylinder



1. Intake water screens
2. Water pump
3. Water tube
4. Exhaust housing
5. Cylinder block
6. Pressure relief valve
7. Thermostat
8. Water supply to vapor separator
9. Water supply, vapor separator to EMM
10. Overboard indicator, outgoing water from EMM

 Outgoing water (warm/hot)  
 Incoming water (cool)



# Lanyard Switch / Emergency Stop Circuits

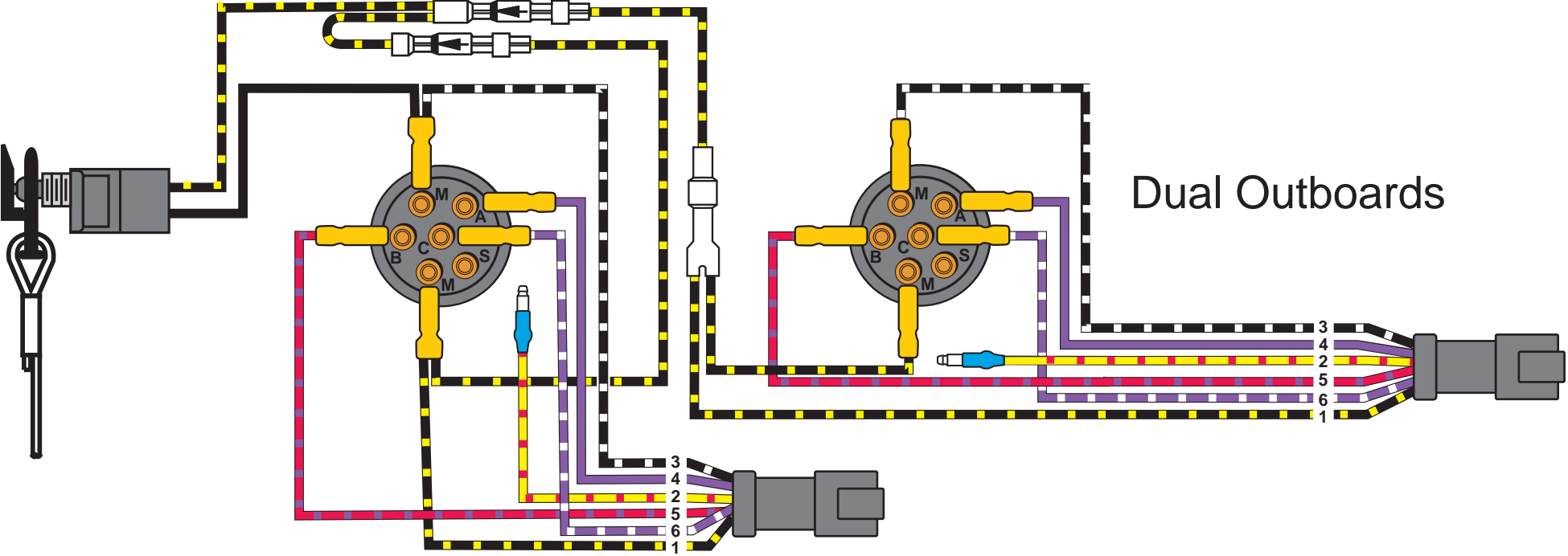
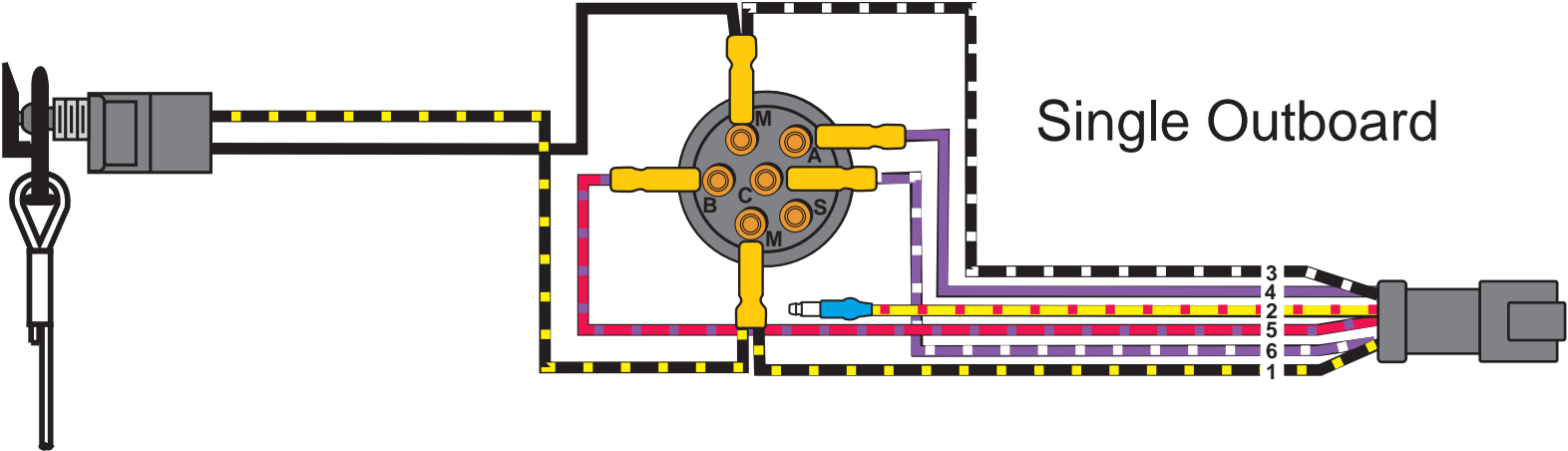

# MWS Key Switch and Neutral Safety Switch

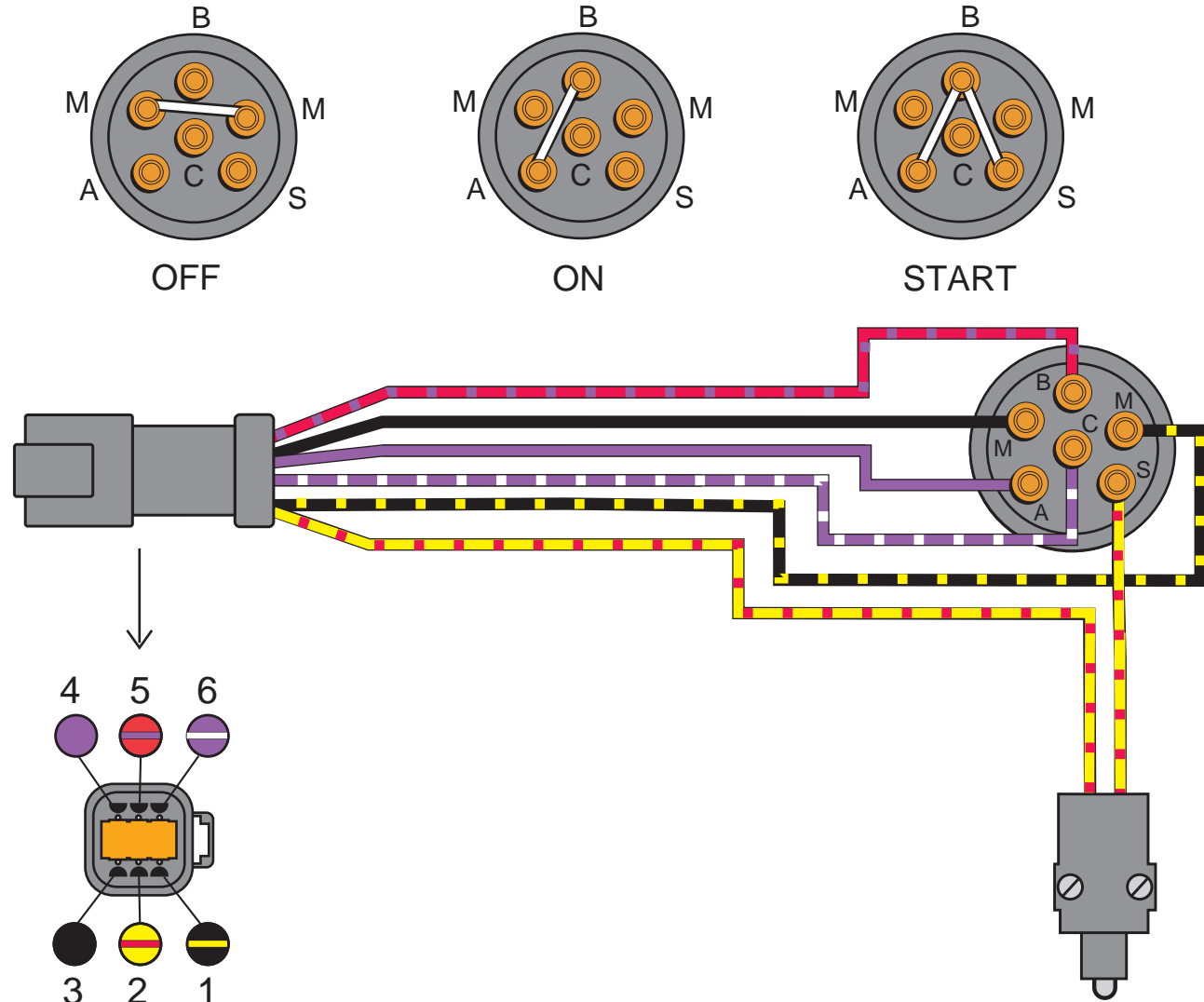

# MWS DASHBOARD

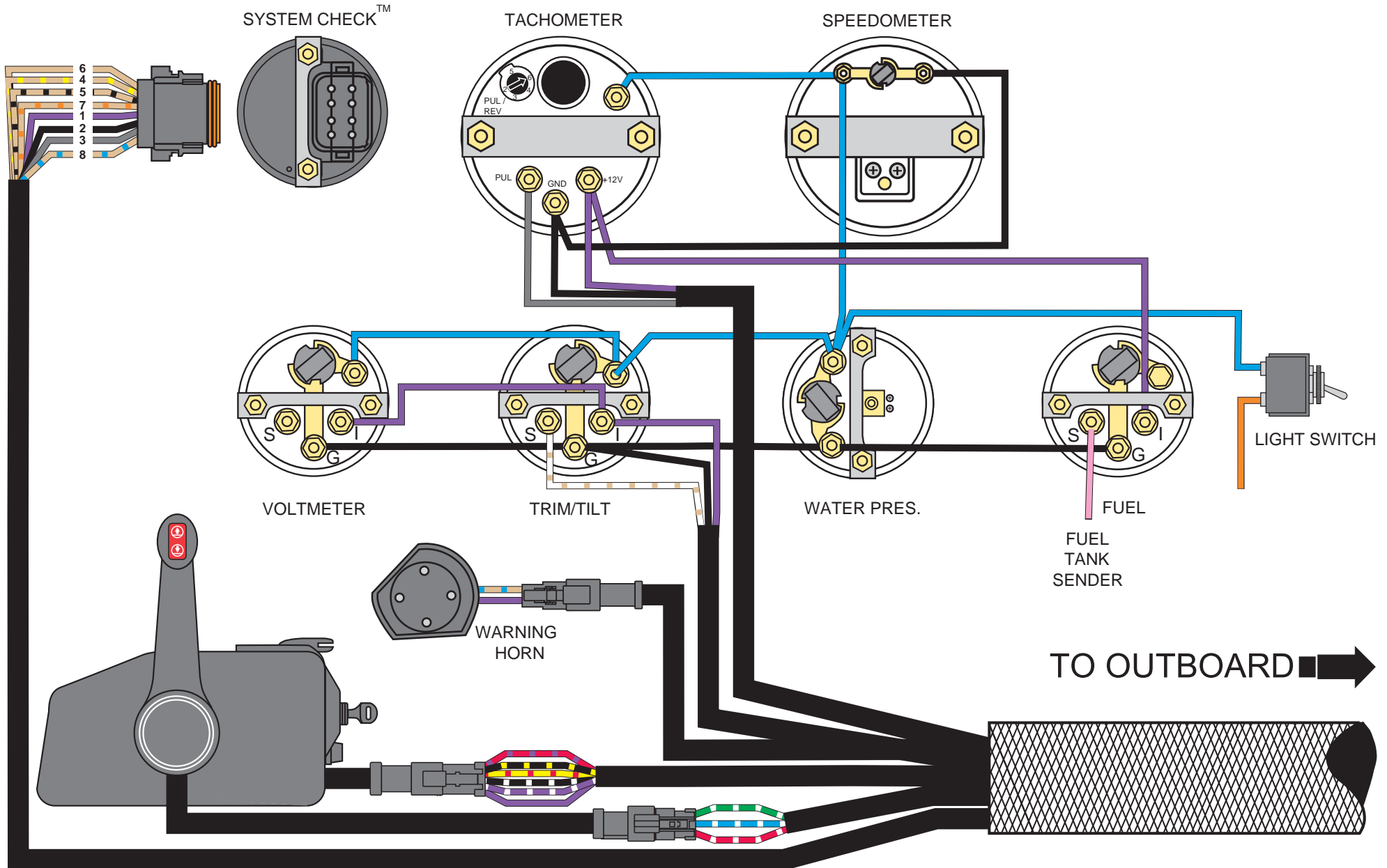

# Tiller Harness 15 – 30 HP E-TEC



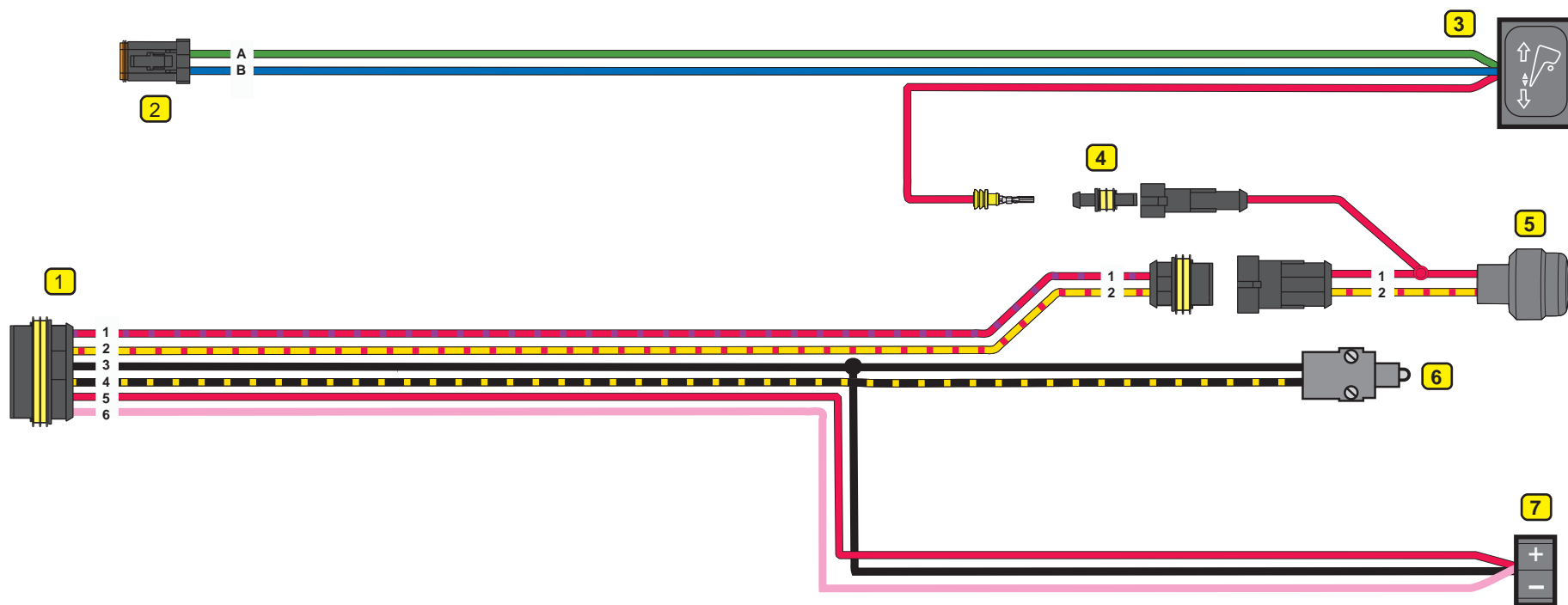

1. Tiller to Engine Harness Connector
2. Trim Switch Connector
3. Trim Switch
4. Power Connector (Trim Switch)
5. Start Switch
6. Stop Switch
7. Touch Troll Switch

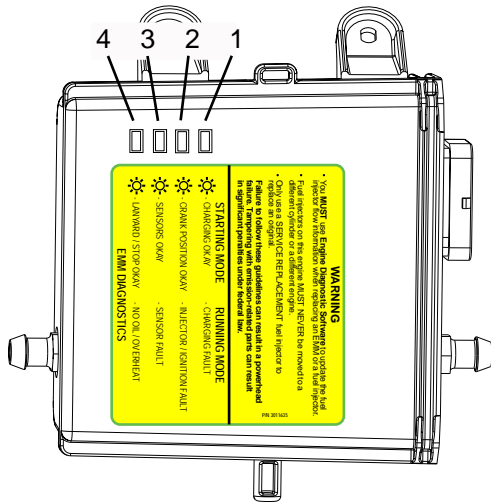

# Evinrude E-TEC EMM LED Diagnostic Indicators

## In-line 15–30HP Models



- 1  — Charging / 55V Circuit
- 2  — CPS OK - Injection/Ignition/Fault
- 3  — Sensors / 5V Circuits
- 4  — Stop Circuit - No Oil/Overheat

For more information, refer to **SYSTEM ANALYSIS** in the Service Manual.

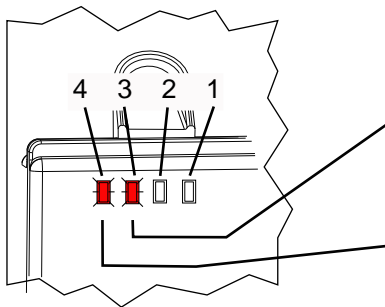

### KEY ON: LED's illuminate to indicate circuit function

Sensors / 5V Circuits OK  
FLASHING LED – URGENT condition – Code 57  
Engine will not start – Correct problem and clear codes

Stop circuit OK (not grounded)  
FLASHING LED – URGENT overheating or no oil condition  
Engine will not start – Correct problem and clear codes

**Note:** No LED's ON indicates EMM not receiving battery voltage or Recoil Start model.

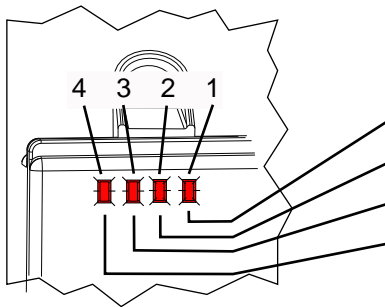

### STARTING : LED's illuminate to indicate circuit function

Indicates 30V (or higher) on 55V circuit  
Indicates CPS working and EMM SYNC  
Sensor circuits working  
Stop circuit OK

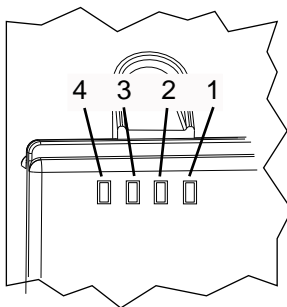

### RUNNING : LED's illuminate to indicate circuit fault

Exception: ALL LED's ON / FLASHING indicates Winterization Mode





# 15 – 30 HP E-TEC

- 1. Air Temperature Sensor
- 2. Throttle Position Sensor
- 3. Crankshaft Position Sensor
- 4. Stator
- 5. Tiller Arm Connector
- 6. CANbus Connector
- 7. Key Switch Connector
- 8. SystemCheck Connector
- 9. Neutral Switch
- 10. Diagnostic Connector
- 11. Cylinder Head Temperature Sensor
- 12. Ignition Coil
- 13. Fuel Injector
- 14. EMM
- 15. High Pressure Fuel Pump
- 16. Low Oil Switch
- 17. Oil Injector
- 18. Main Harness Ground
- 19. Battery Charge Module
- 20. Fuse (10 Amp)
- 21. Starter Solenoid
- 22. Electric Starter**
- 23. Trim Switch Connector
- 24. Trim / Tilt Relay Module
- 25. Trim / Tilt Motor
- 26. Trim Sending Unit

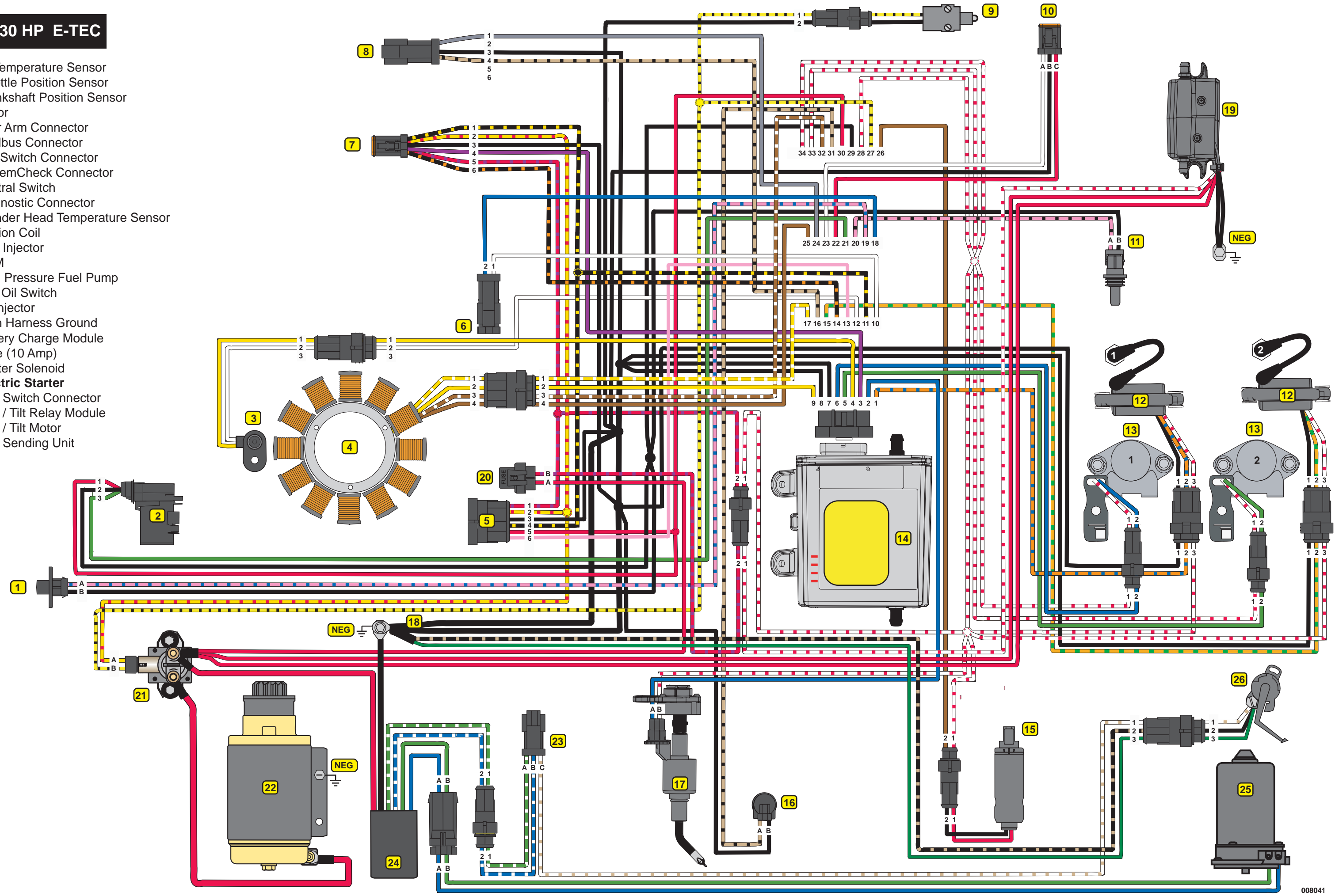



## EVINRUDE 15 – 30 HP EMM SERVICE CODE CHART

CODE	EMM CIRCUIT/SENSOR	INTERNAL SENSOR	S.A.F.E	SHUT DOWN	EMM LED DISPLAY	TIME TO ACTIVATE	SENSOR: CIRCUIT VOLTAGE / RESISTANCE (Ω) / INFORMATION
11	Throttle Position Sensor (TPS) out of idle range				-	2 seconds	TPS Voltage > 1.71 V with key ON (or cranking). Becomes stored fault when outboard starts. When both hard and stored faults are present, check for improperly adjusted throttle cable.
12	Throttle Position Sensor (TPS) circuit fault				LED 3: OFF (Cranking) / ON (Running)	0.8 seconds	TPS Voltage: < 0.14 V, or > 4.92 V. Engine limited to idle speed. Check sensor resistance—3000 to 7000 Ω (between pins A and B) & 4000 to 8000 Ω (between pins A and C)
13	TPS below range				LED 3: OFF (Cranking) / ON (Running)	8 seconds	TPS Voltage < 0.2 V. Check linkage and IDLE stop.
14	TPS above range				LED 3: OFF (Cranking) / ON (Running)	8 seconds	TPS Voltage > 4.85 V. Check linkage and WOT stop.
15	ROM (EMM program)	✓			-	-	ROM "CHECKSUM" failure. Check software program number in EMM. Reload or replace with proper program.
16	Crankshaft Position Sensor (CPS) Intermittent loss of SYNC				LED 2: OFF (Cranking) LED 3: ON (Running)	10 instances	EMM counts losses of synchronization with crankshaft sensor. Check CPS mounting and resistance. Air gap range: 00.036 to 0.110 in. (1 to 2.8 mm), nominal 0.073 in. (1.85 mm) Resistance: 560 Ω ± 10% @ 77°F (25°C)
17	55 V circuit BELOW range	✓	✓		LED 1: ON (Running)	1 minute	System Voltage < 45 V. Engine limited to 1200 RPM. Perform stator/charging tests.
18	55 V circuit ABOVE range	✓	✓		LED 1: ON (Running)	1 minute	System Voltage > 57 V. Engine limited to 1200 RPM. Perform stator/charging tests. Check for loose connections in 55 V circuit.
19	Start-in-gear				LED 3: OFF (Cranking)	-	Attempted engine start while in gear. Engine will not start.
21	Winterization activated				All LEDs FLASHING	-	Engine is speed limited, and stops after 360 oil pulses. Refer to Maintenance or Operator's Guide.
23	EMM Temperature Sensor circuit fault	✓			LED 3: OFF (Cranking) / ON (Running)	8 seconds	EMM Temperature < -71° F (-57.4° C), or > 313° F (156° C).
24	EMM Temperature BELOW range	✓			LED 3: OFF (Cranking) / ON (Running)	8 seconds	EMM Temperature < -22° F (-30° C).
25	EMM Temperature ABOVE range	✓	✓		LED 4: ON (Running)	8 seconds	EMM Temperature > 194°F (90°C). Engine limited to 1200 RPM. See Code 29.
26	12 V circuit BELOW range	✓			LED 1: ON (Running)	5 minutes	Battery voltage < 12.5 V. Perform stator/charging tests.
27	12 V circuit ABOVE range	✓			LED 1: ON (Running)	5 minutes	Battery voltage > 15.5 V. Check battery connections and wiring.
29	EMM Temperature OVER range	✓		✓	LED 4: FLASHING	4 seconds	EMM Temperature > 212° F (100° C). Engine SHUTDOWN. Will NOT restart until EMM temperature returns to operating range. Check outboard and EMM cooling systems.
31	Engine temperature OVER range			✓	LED 4: FLASHING	8 seconds	Engine Temperature > 248° F (120° C) Engine SHUTDOWN. Check cooling system. Check temperature sensor resistance—9000 to 11000 Ω @ 77°F (25°C).
33	Critical NO OIL detected	✓		✓	LED 4: FLASHING	3 hours	Outboard has run three hours with code 34 or 117. Engine SHUTDOWN. Will restart and run for 1 minute intervals.
34	Oil injection pump circuit OPEN		✓		LED 4: ON (Running)	4 seconds	Engine limited to 1200 RPM. Check oil injection pump circuit resistance—22 Ω.
40	Engine Temperature ABOVE range—Low speed		✓		LED 4: ON (Running)	8 seconds	Engine Temperature > 212° F (100° C) below 3500 RPM.
41	Engine Temperature Sensor circuit fault				LED 3: OFF (Cranking) / ON (Running)	8 seconds	Engine Temperature < -15° F (-26.2° C), or > 332° F (166.5° C). Check 5 V circuit and ground (NEG), and sensor resistance—9000 to 11000 Ω @ 77°F (25°C).
42	Engine Temperature BELOW range				LED 3: OFF (Cranking) / ON (Running)	8 seconds	Engine Temperature < -4° F (-20° C). Check engine temperature and sensor resistance.
43	Engine Temperature ABOVE range		✓		LED 4: ON (Running)	8 seconds	Engine Temperature > 194° F (90° C) above 3500 RPM Engine limited to 1200 RPM. Check cooling system.
44	Barometric Pressure (BP) Sensor circuit fault	✓			-	8 seconds	Pressure < 3.9 in. Hg (13.3 kPa), or > 35.1 in. Hg (119.0 kPa). Check atmospheric condition for comparison. Clear code and retest.
45	BP Sensor BELOW range	✓			-	8 seconds	Pressure < 20.7 in. Hg (70 kPa).
46	BP Sensor ABOVE range	✓			-	8 seconds	Pressure > 31 in. Hg (105 kPa).
47	Air Temperature (AT) circuit fault				LED 3: OFF (Cranking) / ON (Running)	8 seconds	Air temperature < -58° F (-49.9° C), or > 218° F (103.2° C). Check 5 V circuit and ground (NEG), and sensor resistance—9000 to 11000 Ω @ 77°F (25°C).
48	Air Temperature BELOW range				LED 3: OFF (Cranking) / ON (Running)	8 seconds	Air temperature < -22° F (-30° C).

CODE	EMM CIRCUIT/SENSOR	INTERNAL SENSOR	S.A.F.E	SHUT DOWN	EMM LED DISPLAY	TIME TO ACTIVATE	SENSOR: CIRCUIT VOLTAGE / RESISTANCE (Ω) / INFORMATION
49	Air Temperature ABOVE range				LED 3: OFF (Cranking) / ON (Running)	8 seconds	Air temperature > 158° F (70° C).
51	Fuel injector circuit #1 OPEN				LED 2: ON (Running)	8 seconds	Check injector/circuit resistance—2 to 3 Ω @ 72°F (22°C).
52	Fuel injector circuit #2 OPEN				LED 2: ON (Running)	8 seconds	
57	High RPM with low TPS setting	✓		✓	LED 3: FLASHING	10 seconds	TPS < 5% and RPM > 3000. Engine SHUTDOWN. Will NOT restart until code has been cleared. The problem could be caused by uncontrolled fuel entering the engine. DO NOT attempt to start the outboard until the problem has been found and repaired.
58	Operating temperature not reached				LED 3: OFF (Cranking) / ON (Running)	9 minutes	Engine temperature < 104° F (40° C) with engine speed < 2300 RPM. Check thermostat and pressure relief valve.
61	Fuel injector circuit #1 SHORTED				LED 2: ON (Running)	8 seconds	Check injector/circuit resistance—2 to 3 Ω @ 72°F (22°C).
62	Fuel injector circuit #2 SHORTED				LED 2: ON (Running)	8 seconds	
78	Sensor supply voltage fault	✓			LED 3: OFF (Cranking) / ON (Running)	10 seconds	Sensor voltage < 4.75 V. Check sensors and related wiring. Check for pinched or chafed wiring.
81	Ignition timing circuit #1 OPEN				LED 2: ON (Running)	10 instances	EMM counts failed ignition events. Check wiring. Test with known good ignition coil.
82	Ignition timing circuit #2 OPEN				LED 2: ON (Running)	10 instances	
91	Fuel pump circuit OPEN				LED 2: ON (Running)	8 seconds	Check pump/circuit resistance—2 to 3 Ω @ 77°F (25°C).
94	Fuel pump circuit SHORTED				LED 2: ON (Running)	2 seconds	Check pump/circuit resistance—2 to 3 Ω @ 77°F (25°C).
101	Ignition timing circuit #1 SHORTED				LED 2: ON (Running)	5 events-low speed 2 events-high speed	EMM counts failed ignition events. Check wiring. Test with known good ignition coil.
102	Ignition timing circuit #2 SHORTED				LED 2: ON (Running)	5 events-low speed 2 events-high speed	
117	Critical LOW OIL detected	✓	✓		LED 4: ON (Running)	6700 Pulses	EMM counts oil pump pulses after LOW OIL switch closes. Engine limited to 1200 RPM. Stop outboard and add oil to tank. Warning resets after three oil pump pulses.
120	Oil level sensor OPEN		✓		LED 4: ON (Running)	4 seconds	Check switch continuity—open below 1/4 capacity, closed above 1/4 capacity.

NOTE: Always note service codes before clearing codes. Clear stored codes using diagnostic software. Clearing some codes requires turning EMM "OFF" and then "ON" again.







5 0 0 4 3 2 6

