



---

# SEA-DOO®



<--- CLICK BOOKMARKS TO OPEN MENU

Shop  
Manual

2006

4-TEC™ Series



---

# TABLE OF CONTENTS

---

<b>SAFETY NOTICE</b> .....	<b>VIII</b>
<b>INTRODUCTION</b> .....	<b>IX</b>
GENERAL INFORMATION.....	IX
HULL IDENTIFICATION NUMBER (H.I.N.) .....	IX
ENGINE IDENTIFICATION NUMBER (E.I.N.) .....	X
ARRANGEMENT OF THIS MANUAL, ILLUSTRATIONS AND PROCEDURES .....	X
ENGINE EMISSIONS INFORMATION .....	XIV
WORKING ON WATERCRAFT .....	XIV
SELF-LOCKING FASTENERS PROCEDURE .....	XIV
LOCTITE APPLICATION PROCEDURE.....	XV
TIGHTENING TORQUES .....	XIX
<b>01 MAINTENANCE</b>	
<b>01 – MAINTENANCE CHART</b> .....	<b>1</b>
<b>02 – PRESEASON PREPARATION</b> .....	<b>3</b>
<b>03 – STORAGE PROCEDURES</b> .....	<b>5</b>
PROPULSION SYSTEM.....	5
FUEL SYSTEM .....	5
ENGINE .....	6
ELECTRICAL SYSTEM.....	7
VEHICLE .....	7
CHECKLIST .....	8
<b>04 – SPECIAL PROCEDURES</b> .....	<b>9</b>
TOWING THE WATERCRAFT IN WATER.....	9
SUBMERGED WATERCRAFT .....	9
WATER-FLOODED ENGINE .....	10
<b>02 TROUBLESHOOTING</b>	
<b>01 – TROUBLESHOOTING CHART</b> .....	<b>13</b>
ENGINE .....	13
STARTING SYSTEM.....	22
ELECTRICAL SYSTEM.....	23
PROPULSION .....	24
STEERING SYSTEM.....	24
<b>03 ENGINE</b>	
<b>01 – ENGINE REMOVAL AND INSTALLATION</b> .....	<b>25</b>
GENERAL .....	25
PROCEDURES .....	25
ENGINE REMOVAL .....	25
CLEANING .....	29
INSTALLATION .....	29
ENGINE ALIGNMENT.....	29
<b>02 – ENGINE LEAK TEST</b> .....	<b>33</b>
PREPARATION .....	33
PROCEDURE .....	34
<b>03 – AIR INTAKE SYSTEM</b> .....	<b>37</b>
INSPECTION.....	39
REMOVAL .....	39
INSTALLATION .....	40
<b>04 – INTAKE MANIFOLD AND INTERCOOLER</b> .....	<b>41</b>
PROCEDURES .....	45
INTAKE MANIFOLD.....	45
INTERCOOLER .....	50



---

# TABLE OF CONTENTS

---

<b>05 – SUPERCHARGER</b> .....	<b>53</b>
INSPECTION(SUPERCHARGER INSTALLED).....	55
REMOVAL.....	56
DISASSEMBLY.....	57
PARTS INSPECTION.....	59
ASSEMBLY.....	60
INSTALLATION.....	64
<b>06 – EXHAUST SYSTEM</b> .....	<b>67</b>
GENERAL.....	69
EXHAUST SYSTEM COOLING.....	69
<b>MAINTENANCE</b> .....	<b>72</b>
EXHAUST SYSTEM FLUSHING.....	72
<b>PROCEDURES</b> .....	<b>74</b>
EXHAUST PIPE.....	74
EXHAUST MANIFOLD.....	77
MUFFLER.....	78
RESONATOR.....	78
EXHAUST OUTLET.....	79
<b>07 – PTO HOUSING AND MAGNETO</b> .....	<b>81</b>
GENERAL.....	83
<b>PROCEDURES</b> .....	<b>83</b>
PTO HOUSING.....	83
PTO SEAL.....	86
COUPLING.....	86
STATOR.....	87
ROTOR AND TRIGGER WHEEL.....	88
RING GEAR.....	89
STARTER DRIVE.....	90
OIL SPRAY NOZZLE.....	91
<b>08 – LUBRICATION SYSTEM</b> .....	<b>93</b>
<b>MAINTENANCE</b> .....	<b>96</b>
OIL LEVEL VERIFICATION.....	96
OIL CHANGE.....	96
OIL FILTER.....	97
<b>INSPECTION</b> .....	<b>98</b>
ENGINE OIL PRESSURE.....	98
<b>PROCEDURES</b> .....	<b>99</b>
PTO OIL STRAINER.....	99
SUCTION PUMP OIL STRAINER.....	100
ENGINE OIL PRESSURE REGULATOR.....	102
OIL PRESSURE PUMP.....	102
OIL SUCTION PUMP.....	106
OIL SEPARATOR COVER.....	108
TOPS VALVE.....	110
OIL COOLER.....	111
<b>09 – COOLING SYSTEM</b> .....	<b>113</b>
GENERAL.....	116
CIRCUIT.....	116
TECHNICAL SPECIFICATIONS.....	116
<b>INSPECTION</b> .....	<b>116</b>
PRESSURE CAP.....	116
HOSES AND CLAMPS.....	116
COOLING SYSTEM LEAK TEST.....	116
<b>MAINTENANCE</b> .....	<b>117</b>
COOLANT REPLACEMENT.....	117
<b>PROCEDURES</b> .....	<b>119</b>



## TABLE OF CONTENTS

	CLAMPS .....	119
	WATER PUMP HOUSING .....	120
	WATER PUMP IMPELLER .....	121
	THERMOSTAT .....	121
	ROTARY SEAL .....	122
<b>10</b>	<b>– CYLINDER HEAD .....</b>	<b>125</b>
	GENERAL .....	127
	PROCEDURES .....	127
	EXHAUST MANIFOLD .....	127
	VALVE COVER .....	127
	ROCKER ARM .....	128
	CAMSHAFT TIMING GEAR .....	131
	TIMING CHAIN .....	132
	CYLINDER HEAD .....	132
	CAMSHAFT .....	134
	VALVE SPRING .....	135
	VALVE .....	137
<b>11</b>	<b>– CYLINDER BLOCK .....</b>	<b>143</b>
	GENERAL .....	146
	PROCEDURES .....	146
	TIMING CHAIN .....	146
	CHAIN TENSIONER .....	146
	PISTON/CONNECTING ROD .....	147
	PISTON RINGS .....	151
	CRANKSHAFT .....	153
	BALANCER SHAFT .....	157
	CYLINDER BLOCK .....	160
<b>04</b>	<b>ENGINE MANAGEMENT (1503 4-TEC) .....</b>	
	<b>01 – OVERVIEW .....</b>	<b>165</b>
	GENERAL .....	166
	OPERATING PRINCIPLE .....	166
	AIR INDUCTION .....	166
	FUEL SYSTEM .....	167
	ELECTRICAL SYSTEM .....	168
	ENGINE MANAGEMENT SYSTEM (EMS) .....	171
	ELECTRONIC FUEL INJECTION .....	171
	IGNITION SYSTEM .....	171
	ENGINE MODES OF OPERATION .....	171
	MONITORING SYSTEM .....	172
	DIAGNOSTIC MODE .....	172
	ENGINE MANAGEMENT SYSTEM DIAGRAM .....	173
	<b>02 – EMS DIAGNOSTIC AND COMMUNICATION TOOLS .....</b>	<b>175</b>
	GENERAL .....	175
	DIAGNOSTIC .....	176
	MONITORING SYSTEM .....	176
	FAULT CODES .....	177
	COMMUNICATION TOOLS .....	179
	MPI (MULTI-PURPOSE INTERFACE) .....	179
	MPI-2 (MULTI-PURPOSE INTERFACE) .....	181
	B.U.D.S. SOFTWARE .....	182
	<b>03 – ADJUSTMENT AND REPAIR PROCEDURES .....</b>	<b>185</b>
	GENERAL .....	185
	FUEL SYSTEM .....	185
	ELECTRICAL SYSTEM .....	186
	BASIC ADJUSTMENTS .....	191



---

# TABLE OF CONTENTS

---

IDLE SPEED .....	191
THROTTLE CABLE .....	191
CLOSED THROTTLE AND IDLE ACTUATOR RESET .....	192
IGNITION TIMING .....	192
<b>REPAIR PROCEDURES .....</b>	<b>192</b>
ENGINE CONTROL MODULE (ECM).....	192
MULTI-PURPOSE ELECTRONIC MODULE (MPEM) .....	193
FUEL INJECTOR .....	194
THROTTLE BODY .....	196
THROTTLE POSITION SENSOR (TPS) .....	197
IDLE BYPASS VALVE .....	199
CRANKSHAFT POSITION SENSOR (CPS).....	199
CAMSHAFT POSITION SENSOR (CAPS).....	200
MANIFOLD AIR TEMPERATURE SENSOR (MATS) .....	201
COOLANT TEMPERATURE SENSOR (CTS).....	202
MANIFOLD AIR PRESSURE SENSOR (MAPS) .....	202
EXHAUST GAS TEMPERATURE SENSOR (EGTS) .....	203
KNOCK SENSOR (KS).....	204
OIL PRESSURE SENSOR (OPS) .....	204
TOPS SWITCH.....	205
<b>05 FUEL SYSTEM .....</b>	
<b>01 – FUEL TANK AND FUEL PUMP .....</b>	<b>207</b>
GENERAL.....	209
INSPECTION .....	209
FUEL SYSTEM LEAK TEST.....	209
FUEL PUMP PRESSURE TEST .....	211
PROCEDURES .....	212
FUEL HOSES AND OETIKER CLAMPS.....	212
FUEL FILTER.....	213
FUEL TANK .....	213
FUEL PUMP .....	215
<b>06 ELECTRICAL SYSTEM .....</b>	
<b>01 – IGNITION SYSTEM .....</b>	<b>219</b>
GENERAL.....	221
PROCEDURES .....	221
IGNITION COIL .....	221
SPARK PLUGS.....	223
<b>02 – CHARGING SYSTEM .....</b>	<b>225</b>
GENERAL.....	227
TESTING PROCEDURE .....	227
RECTIFIER/REGULATOR .....	228
STATOR .....	228
BATTERY.....	230
<b>03 – STARTING SYSTEM .....</b>	<b>237</b>
GENERAL.....	240
TEST.....	240
ELECTRICAL CABLES OR CONNECTIONS .....	240
FUSE .....	240
ENGINE CONTROL MODULE (ECM).....	240
ENGINE START/STOP SWITCH .....	240
SOLENOID .....	241
PARTS REPLACEMENT.....	242
STARTER.....	242
STARTER GEAR .....	243



## TABLE OF CONTENTS

<b>04 – DIGITALLY ENCODED SECURITY SYSTEM (DESS) .....</b>	<b>245</b>
GENERAL .....	245
KEY PROGRAMMING .....	246
TROUBLESHOOTING .....	247
<b>05 – GAUGE, SENSORS AND FUSES .....</b>	<b>249</b>
GENERAL .....	249
FUSES .....	250
INFORMATION CENTER .....	252
PROCEDURES .....	254
INFORMATION CENTER .....	254
FUEL BAFFLE PICK-UP SENDER .....	256
WATER TEMPERATURE SENSOR .....	256
COMPASS .....	256
SPEED SENSOR .....	257
DEPTH GAUGE .....	257
<b>07 PROPULSION</b>	
<b>01 – JET PUMP .....</b>	<b>259</b>
GENERAL .....	262
INSPECTION .....	262
IMPELLER CONDITION .....	262
IMPELLER/WEAR RING CLEARANCE .....	262
LEAK TEST .....	262
PROCEDURES .....	263
SACRIFICIAL ANODE .....	263
VENTURI .....	263
JET PUMP HOUSING .....	264
IMPELLER COVER .....	266
IMPELLER .....	267
WEAR RING .....	269
IMPELLER SHAFT AND BEARING .....	270
<b>02 – DRIVE SYSTEM .....</b>	<b>275</b>
GENERAL .....	277
MAINTENANCE .....	277
CORROSION PROTECTION .....	277
PROCEDURES .....	277
DRIVE SHAFT .....	277
BOOT .....	284
CARBON RING .....	284
<b>03 – REVERSE SYSTEM .....</b>	<b>285</b>
GENERAL .....	287
PROCEDURES .....	287
REVERSE CABLE .....	287
REVERSE CABLE LEVER .....	288
SHIFT LEVER .....	289
REVERSE CABLE SUPPORT .....	290
SHIFT LEVER HOUSING .....	290
REVERSE GATE .....	291
PIVOT SUPPORT .....	291
LINK ROD .....	291
PIVOT TRIANGLE .....	292
PIVOT ARM .....	292
<b>04 – VARIABLE TRIM SYSTEM .....</b>	<b>293</b>
GENERAL .....	295
TEST .....	295
SWITCH .....	295



---

# TABLE OF CONTENTS

---

MOTOR .....	295
CONTROL MODULE.....	295
<b>PROCEDURES .....</b>	<b>295</b>
CONTROL MODULE AND MOTOR .....	295
<hr/>	
<b>08 STEERING SYSTEM</b>	
<b>01 – STEERING SYSTEM .....</b>	<b>299</b>
GENERAL.....	301
ADJUSTMENT.....	301
STEERING ALIGNMENT.....	301
<b>PROCEDURES .....</b>	<b>302</b>
NOZZLE.....	302
HANDLEBAR GRIP.....	302
STEERING COVER.....	303
STEERING PADDING .....	304
HANDLEBAR .....	305
STEERING CABLE SUPPORT.....	306
STEERING SUPPORT.....	307
STEERING STEM.....	308
HANDLEBAR SUPPORT.....	308
STEERING CABLE.....	309
<b>02 – OFF-POWER ASSISTED STEERING (O.P.A.S.) .....</b>	<b>311</b>
GENERAL.....	314
<b>PROCEDURES .....</b>	<b>314</b>
FILTER.....	314
VALVE .....	315
WATER HOSE .....	316
SIDE VANE.....	316
CYLINDER SUPPORT.....	317
TIE ROD.....	319
SEALED TUBE.....	320
CROSS SUPPORT PLATE .....	320
<hr/>	
<b>09 HULL/BODY</b>	
<b>01 – ADJUSTMENT AND REPAIR .....</b>	<b>323</b>
GENERAL.....	340
<b>PARTS REPLACEMENT.....</b>	<b>340</b>
DECALS.....	340
GLOVE BOX .....	340
SEAT.....	342
REMOVABLE SEAT COWLING .....	343
SEAT COVER .....	343
SEAT LATCH.....	344
ENGINE COVER.....	345
STORAGE COMPARTMENT COVER .....	345
STORAGE COMPARTMENT COVER HINGE.....	347
STORAGE COMPARTMENT COVER SHOCK.....	347
STORAGE COMPARTMENT COVER LATCH.....	348
STORAGE COMPARTMENT COVER INNER SHELL .....	348
FRONT GRILL OF COMPARTMENT COVER.....	351
ACCESS COVER.....	352
CONSOLE.....	352
MIRROR .....	354
DEFLECTOR AND/OR UPPER GRID.....	354
SIDE MOLDING .....	355
INLET GRATE .....	355

---

## TABLE OF CONTENTS

---

RIDING PLATE.....	356
JET PUMP SUPPORT.....	357
THRU-HULL FITTING.....	358
BUMPER.....	359
WAKE PYLON.....	359
SPONSON.....	360
SPONSON ADAPTOR.....	361
DRAIN PLUG.....	361
CARPET.....	362
<b>CLEANING.....</b>	<b>362</b>
SEAT.....	362
BODY AND HULL.....	363
CARPET.....	363
<b>REPAIR.....</b>	<b>363</b>
HULL AND BODY.....	363
TOOLS AND MATERIALS LIST.....	366
<hr/>	
<b>10 TECHNICAL SPECIFICATIONS</b>	
<b>01 – GTI AND GTI SE.....</b>	<b>367</b>
<b>02 – GTX AND GTX WAKE.....</b>	<b>373</b>
<b>03 – GTX SUPERCHARGED AND GTX LIMITED.....</b>	<b>379</b>
<b>04 – RXP AND RXT MODELS.....</b>	<b>385</b>
<hr/>	
<b>11 ELECTRICAL CONNECTORS AND WIRING DIAGRAM</b>	
<b>01 – ELECTRICAL CONNECTORS.....</b>	<b>391</b>
DEUTSCH CONNECTORS.....	391
PACKARD CONNECTOR.....	393
AMP CONNECTOR.....	393
ECM CONNECTORS.....	397
BATTERY AND STARTER CABLE TERMINALS.....	400
<b>02 – WIRING DIAGRAM.....</b>	<b>403</b>
WIRE COLOR CODES.....	403
WIRE DIGIT CODES.....	403



---

## SAFETY NOTICE

---

# SAFETY NOTICE

This manual has been prepared as a guide to correctly service and repair 2006 SEA-DOO watercraft as describe in the model list in the *INTRODUCTION*.

This edition was primarily published to be used by watercraft mechanical technicians who are already familiar with all service procedures relating to BRP made watercraft. Mechanical technicians should attend training courses given by B.R.P.T.I.

Please note that the instructions will apply only if proper hand tools and special service tools are used.

This Shop Manual uses technical terms which may be slightly different from the ones used in the *PARTS CATALOG*.

It is understood that this manual may be translated into another language. In the event of any discrepancy, the English version shall prevail.

The content depicts parts and/or procedures applicable to the particular product at time of writing. Service and Warranty Bulletins may be published to update the content of this manual. Make sure to read and understand these.

In addition, the sole purpose of the illustrations throughout the manual, is to assist identification of the general configuration of the parts. They are not to be interpreted as technical drawings or exact replicas of the parts.

The use of BRP parts is most strongly recommended when considering replacement of any component. Dealer and/or distributor assistance should be sought in case of doubt.

The engines and the corresponding components identified in this document should not be utilized on product(s) other than those mentioned in this document.

### WARNING

Unless otherwise specified, engine should be turned OFF and cold for all maintenance and repair procedures.

This manual emphasizes particular information denoted by the wording and symbols:

### WARNING

Identifies an instruction which, if not followed, could cause serious personal injury including possibility of death.

**CAUTION:** Denotes an instruction which, if not followed, could severely damage vehicle components.

**NOTE:** Indicates supplementary information needed to fully complete an instruction.

Although the mere reading of such information does not eliminate the hazard, your understanding of the information will promote its correct use. Always use common shop safety practice.

BRP disclaims liability for all damages and/or injuries resulting from the improper use of the contents. We strongly recommend that any services be carried out and/or verified by a highly skilled professional mechanic. It is understood that certain modifications may render use of the vehicle illegal under existing federal, provincial and state regulations.

# INTRODUCTION

## GENERAL INFORMATION

This Shop Manual covers the following BRP made SEA-DOO® 2006 watercraft models.

MODEL	COLOR	ENGINE	MODEL NUMBER
GTI	White	1503 Naturally Aspirated (130 HP)	236A, 236B 256A, 256B
GTI SE	Atlantic Blue	1503 Naturally Aspirated (130 HP)	246A, 246B
GTX	Pewter Grey Met.	1503 Naturally Aspirated (155 HP)	146A, 146B
GTX Supercharged	Pewter Grey Met.	1503 Supercharged	166A
GTX Limited	Starlight Blue	1503 Supercharged Intercooled	186A, 186B
GTX Limited	Midnight Black	1503 Supercharged Intercooled	186C
GTX WAKE	Viper Red	1503 Naturally Aspirated (155 HP)	156A, 156B
RXP	Maya Gold	1503 Supercharged Intercooled	216A, 216B
RXP	Viper Red Metallic	1503 Supercharged Intercooled	216C, 216D
RXT	Maya Gold	1503 Supercharged Intercooled	176A, 176B
RXT	Viper Red Metallic	1503 Supercharged Intercooled	176C, 176D

The use of RIGHT (starboard) and LEFT (port) indications in the text, always refers to driving position (when sitting on watercraft).

Besides, in the marine industry, FRONT is called BOW and REAR is called STERN.

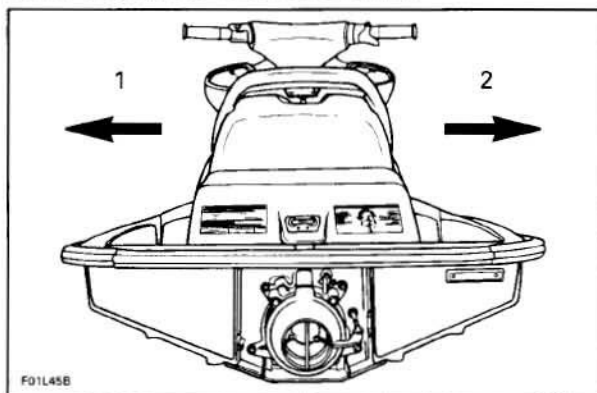

- 1. Left (port)
- 2. Right (starboard)

The information and component/system descriptions contained in this manual are correct at time of writing. BRP however, maintains a policy of continuous improvement of its products without imposing upon itself any obligation to install them on products previously manufactured.

Due to late changes, there may be some differences between the manufactured product and the description and/or specifications in this document.

BRP reserves the right at any time to discontinue or change specifications, designs, features, models or equipment without incurring obligation.

This Shop Manual uses technical terms which may be different from the ones of the *PARTS CATALOGS*.

When ordering parts always refer to the specific model *PARTS CATALOGS*.

## HULL IDENTIFICATION NUMBER (H.I.N.)

The hull identification number is composed of 12 digits:

YDV	12345	L	4	95
				Model year
				Year of production
				Month of production
				Serial number
				(a letter may also be used as a digit)
				Manufacturer

It is located on footboard at the rear of watercraft.



# INTRODUCTION

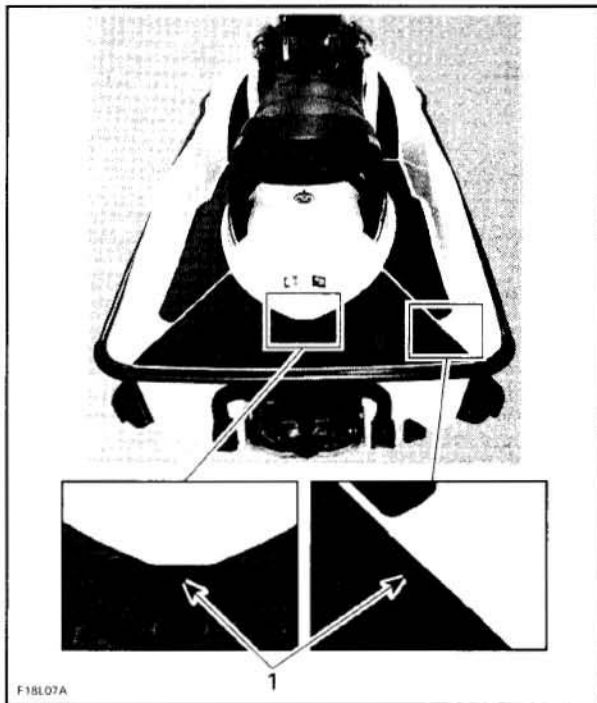

**TYPICAL**  
1. Hull Identification Number (H.I.N.)

## ENGINE IDENTIFICATION NUMBER (E.I.N.)

The Engine Identification Number is located on front end of the engine.



1. Engine Identification Number (E.I.N.)

## ARRANGEMENT OF THIS MANUAL, ILLUSTRATIONS AND PROCEDURES

The manual is divided into many major sections as you can see in the main table of contents at the beginning of the manual.

Each section is divided in various subsections, and again, each subsection has one or more division.

The illustrations show the typical construction of the different assemblies and, in all cases, may not reproduce the full detail or exact shape of the parts shown, however, they represent parts which have the same or a similar function.

**CAUTION:** These watercraft are designed with parts dimensioned mostly in the metric system. However some components may be from the imperial system. When replacing fasteners, make sure to use only those recommended by BRP.

As many of the procedures in this manual are inter-related, we suggest, that before undertaking any task, you read and thoroughly understand the entire section or subsection in which the procedure is contained.

---

## INTRODUCTION

---

A number of procedures throughout the book require the use of special tools. Before undertaking any procedure, be sure that you have on hand all the tools required, or approved equivalents.



# INTRODUCTION

## TYPICAL PAGE

Page heading indicates section and subsection detailed.

Section 03 ENGINE  
Subsection 04 (MAGNETO SYSTEM)

Subsection title indicates beginning of the subsection.

**MAGNETO SYSTEM**

*717 Engine*

Italic sub-title above exploded view indicate pertaining models.

Drop represents a liquid product to be applied to a surface. In this case Loctite 243 to screw threads.

Exploded view assists you in identifying parts and related positions.

Bold face number indicates special procedure concerning this part.

Illustration number for publishing process.

Dotted box contains parts of a particular model or an exploded view.

Tightening torque nearby fastener. In this case, nut must be torqued to 145 N·m (107 lbf·ft).

**CAUTION:** Pay attention to torque specifications. Some of these are in lbf·in instead of lbf·ft. Use appropriate torque wrench.

Page number

F01A0CT

TYPICAL PAGE

Sub-title with part name(s) from exploded view.

**Section 06 FUEL SYSTEM**  
Subsection 03 (CARBURETORS)

Title indicates main procedure to be carried-out.

**CARBURETOR REMOVAL**

To remove carburetors from engine, proceed as follows:  
Remove air vent tube support.  
Unlock retaining slides holding air intake silencer base.  
Remove air intake silencer base from watercraft.  
Remove screws holding flame arrester base support to cylinder head cover.  
Unscrew base retaining screws then remove base from carburetors and move to front of watercraft.  
Turn the valve to OFF position.

Service tool to be used to perform a certain procedure.

**NOTE:** For fuel line removal, use pliers (P/N 295 000 054).

Disconnect pulse line from fuel pump.  
Disconnect fuel fuel supply line from fuel pump.  
Disconnect fuel return line.  
Disconnect oil injection pump cable, throttle cable and choke cable.

Title in italic indicates a particular procedure concerning a model.

*XP Model Only*

Remove screws no. 6 and lock washers no. 7 retaining carburetors.

Sub-sub-title in this case indicates that particular procedure for XP is finished, so from this point, all others models are concerned.

**All Others Models**

Remove 4 bolts no. 8 and lock washers no. 12 from rotary valve cover; then move carburetor and rotary valve cover on top of engine.

**NOTE:** When removing rotary valve cover, pay attention that the rotary valve stay in place, otherwise it must be timed.

Remove carburetors from intake manifold.  
Disconnect fuel bypass line between carburetors (twin carburetors).  
Remove carburetor(s) from rotary valve cover.

**DISASSEMBLY AND INSPECTION**

Inspect parts for corrosion damage (shaft, butterfly, spring, etc.; check valve housing, etc.).

Sub-sub-title in capital indicates a particular testing, adjustment or repair procedure.

**Diaphragm PUMP DIAPHRAGM LEAK TEST**

Using a suitable pump gauge tester, perform the following test proceeding as follows:

- Install pump gauge tester (P/N 295 000 083) on pulse nipple.
- Pump tester until it reaches 28 kPa (4 PSI).

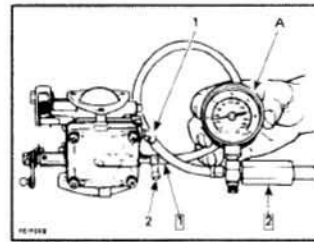

Illustration always follows text it is pertained to.

**TYPICAL**

Step 1: Install pump gauge tester to pulse nipple.

Step 2: Pump tester until it reaches the desired pressure.

1 Fuel outlet nipple

2 Fuel inlet nipple

A 28 kPa (4 PSI)

A diaphragm must stand pressure for 10 seconds. If pressure drops, replace diaphragm.

"TYPICAL" mention indicates a general view which does not represent full detail.

Numbered step are used to give a sequence to be performed.

Letters are used for any measures.

Bold numbers in the text refer to the parts shown in the exploded view at the beginning of the subsection.

Numbers are used for description of components.



## INTRODUCTION

### ENGINE EMISSIONS INFORMATION

#### Manufacturer's Responsibility

Beginning with 1999 model year engines, PWC manufacturers of marine engines must determine the exhaust emission levels for each engine horsepower family and certify these engines with the United States of America Environmental Protection Agency (EPA). An emissions control information label, showing emission levels and engine specifications, must be placed on each vehicle at the time of manufacture.

#### Dealer Responsibility

When performing service on all 1999 and more recent Sea-Doo watercrafts that carry an emissions control information label, adjustments must be kept within published factory specifications.

Replacement or repair of any emission related component must be executed in a manner that maintains emission levels within the prescribed certification standards.

Dealers are not to modify the engine in any manner that would alter the horsepower or allow emission levels to exceed their predetermined factory specifications.

Exceptions include manufacturer's prescribed changes, such as altitude adjustments for example.

#### Owner Responsibility

The owner/operator is required to have engine maintenance performed to maintain emission levels within prescribed certification standards.

The owner/operator is not to, and should not allow anyone to modify the engine in any manner that would alter the horsepower or allow emissions levels to exceed their predetermined factory specifications.

#### EPA Emission Regulations

All new 1999 and more recent Sea-Doo watercrafts manufactured by BRP are certified to the EPA as conforming to the requirements of the regulations for the control of air pollution from new watercraft engines. This certification is contingent on certain adjustments being set to factory standards. For this reason, the factory procedure for servicing the product must be strictly followed and, whenever practicable, returned to the original intent of the design.

The responsibilities listed above are general and in no way a complete listing of the rules and regulations pertaining to the EPA requirements on exhaust emissions for marine products. For more detailed information on this subject, you may contact the following locations:

#### FOR ALL COURIER SERVICES:

U.S. Environmental Protection Agency  
Office of Transportation and Air Quality  
1310 L Street NW  
Washington D.C. 20005

#### REGULAR US POSTAL MAIL:

1200 Pennsylvania Ave. NW  
Mail Code 6403J  
Washington D.C. 20460

INTERNET: <http://www.epa.gov/otaq/>

E-MAIL: [otaqpublicweb@epa.gov](mailto:otaqpublicweb@epa.gov)

### WORKING ON WATERCRAFT

To work on watercraft, securely install it on a stand. Thus, if access is needed to water inlet area, it will be easy to slide underneath watercraft.

The lift kit (P/N 295 100 205) can be used to install watercraft on a stand.

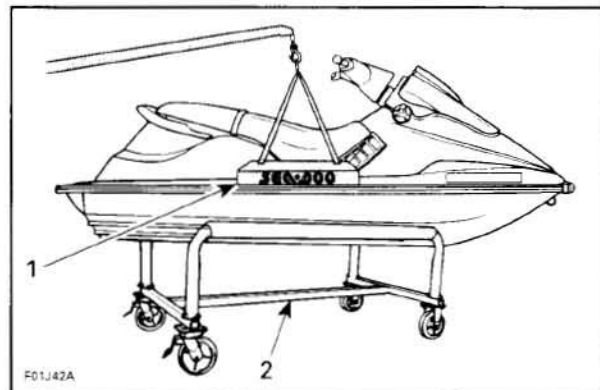

TYPICAL  
1. Lift kit  
2. Work stand

### SELF-LOCKING FASTENERS PROCEDURE

The following describes the most common application procedures when working with self-locking fasteners.

Use a metal brush or a screw tap to clean the hole properly then use a solvent, let act during 30 minutes and wipe off. The solvent utilization is to ensure the adhesive works properly.

## LOCTITE APPLICATION PROCEDURE

The following describes the most common application procedures when working with Loctite products.

**NOTE:** Always use proper strength Loctite product as recommended in this Shop Manual.

### Threadlocker

#### Uncovered Holes (bolts and nuts)

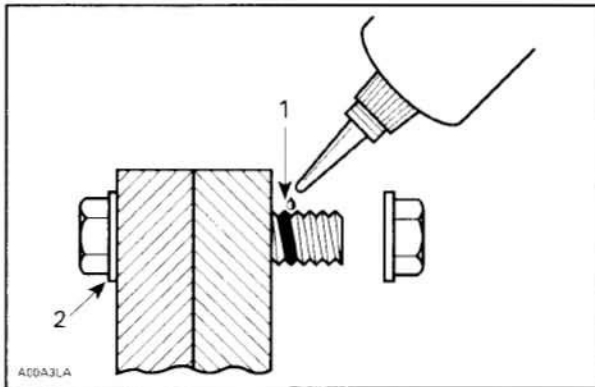

1. Apply here
2. Do not apply

- Clean threads (bolt and nut) with solvent.
- Apply Loctite Primer N (P/N 293 800 041) on threads and allow to dry.
- Choose proper strength Loctite threadlocker.
- Fit bolt in the hole.
- Apply a few drops of threadlocker at proposed tightened nut engagement area.
- Position nut and tighten as required.

#### Blind Holes

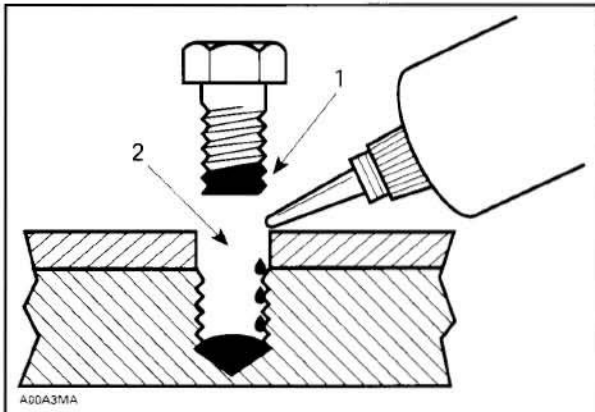

1. On threads
2. On threads and at the bottom of hole

- Clean threads (bolt and nut) with solvent.

- Apply Loctite Primer N (P/N 293 800 041) on threads (bolt and nut) and allow to dry for 30 seconds.
- Choose proper strength Loctite threadlocker.
- Apply several drops along the threaded hole and at the bottom of the hole.
- Apply several drops on bolt threads.
- Tighten as required.

#### Stud in Blind Holes

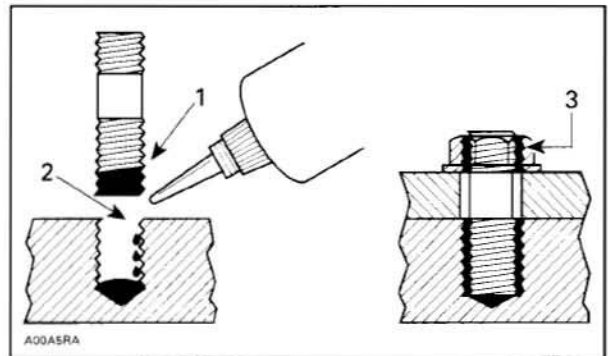

1. On threads
2. On threads and in the hole
3. Onto nut threads

- Clean threads (stud and hole) with solvent.
- Apply Loctite Primer N (P/N 293 800 041) on threads and allow to dry.
- Put several drops of proper strength Loctite threadlocker on female threads and in hole.
- Apply several drops of proper strength Loctite on stud threads.
- Install stud.
- Install cover, etc.
- Apply drops of proper strength Loctite on uncovered threads.
- Tighten nuts as required.



# INTRODUCTION

## Preassembled Parts

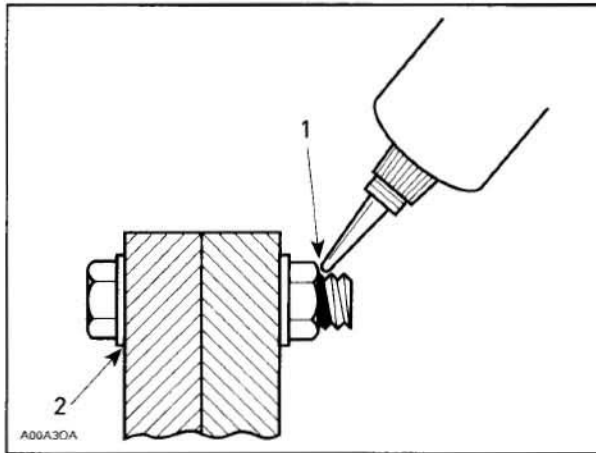

1. Apply here
2. Do not apply

- Clean bolts and nuts with solvent.
- Assemble components.
- Tighten nuts.
- Apply drops of proper strength Loctite on bolt/nut contact surfaces.
- Avoid touching metal with tip of flask.

**NOTE:** For preventive maintenance on existing equipment, retighten nuts and apply proper strength Loctite on bolt/nut contact surfaces.

## Adjusting Screw

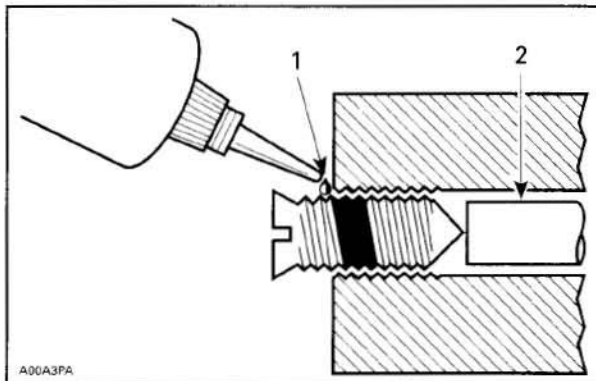

1. Apply here
2. Plunger

- Adjust screw to proper setting.
- Apply drops of proper strength Loctite threadlocker on screw/body contact surfaces.
- Avoid touching metal with tip of flask.

**NOTE:** if it is difficult to readjust, heat screw with a soldering iron (232°C (450°F)).

## Stripped Thread Repair

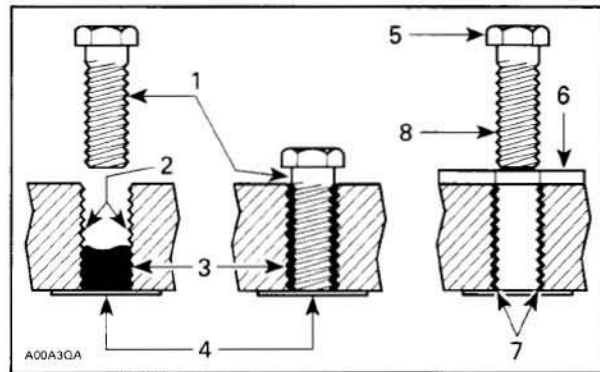

1. Release agent
2. Stripped threads
3. Form-A-Thread
4. Tape
5. Cleaned bolt
6. Plate
7. New threads
8. Threadlocker

## Standard Thread Repair

- Follow instructions on Loctite FORM-A-THREAD 81668 package.
- If a plate is used to align bolt:
  - a. Apply release agent on mating surfaces.
  - b. Put waxed paper or similar film on the surfaces.
- Twist bolt when inserting it to improve thread conformation.

**NOTE:** NOT intended for engine stud repairs.

## Repair of Small Holes/Fine Threads

**Option 1:** Enlarge damaged hole, then follow *STANDARD THREAD REPAIR* procedure.

**Option 2:** Apply FORM-A-THREAD on the screw and insert in damaged hole.

## Permanent Stud Installation (light duty)

- Use a stud or thread on desired length.
- **DO NOT** apply release agent on stud.
- Do a *STANDARD THREAD REPAIR*.
- Allow to cure for 30 minutes.
- Assemble.



## Gasket Compound

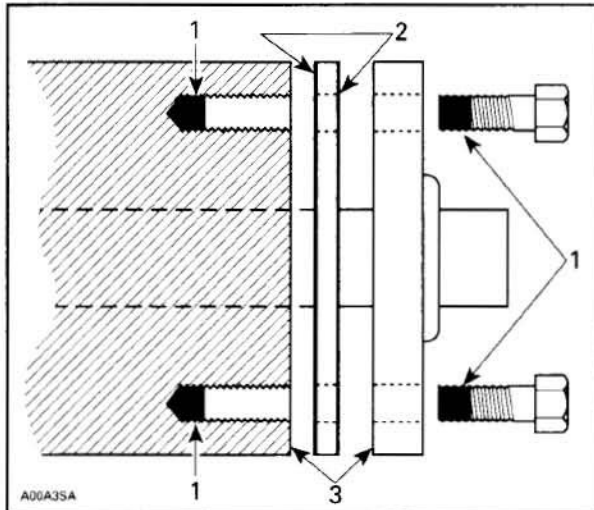

1. Proper strength Loctite
2. Loctite Primer N (P/N 293 800 041) and Gasket Eliminator 518 (P/N 293 800 038) on both sides of gasket
3. Loctite Primer N only

- Remove old gasket and other contaminants with Loctite Chisel remover (P/N 413 708 500). Use a mechanical mean if necessary.

**NOTE:** Avoid grinding.

- Clean both mating surfaces with solvent.
- Spray Loctite Primer N on both mating surfaces and on both sides of gasket. Allow to dry 1 or 2 minutes.
- Apply GASKET ELIMINATOR 518 (P/N 293 800 038) on both sides of gasket, using a clean applicator.
- Place gasket on mating surfaces and assemble immediately.

**NOTE:** If the cover is bolted to blind holes (above), apply proper strength Loctite in the hole and on threads. Tighten.

If holes are sunken, apply proper strength Loctite on bolt threads.

- Tighten as usual.

## Mounting on Shaft

### Mounting with a Press

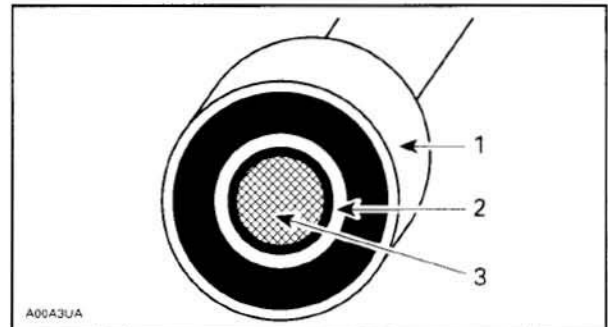

1. Bearing
2. Proper strength Loctite
3. Shaft

- Clean shaft external part and element internal part.
- Apply a strip of proper strength Loctite on shaft circumference at insert or engagement point.

**NOTE:** Retaining compound is always forced out when applied on shaft.

- DO NOT use antiseize Loctite or any similar product.
- No curing period is required.

### Mounting in Tandem

1. Apply retaining compound on internal element bore.
2. Continue to assemble as shown above.

## Case-In Components

### Metallic Gaskets

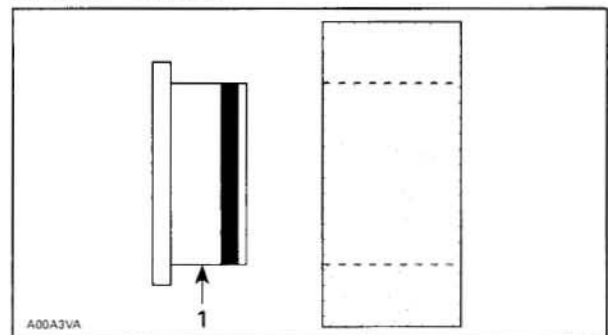

1. Proper strength Loctite

- Clean inner housing diameter and outer gasket diameter.
- Spray housing and gasket with Loctite Primer N (P/N 293 800 041).
- Apply a strip of proper strength Loctite on leading edge of outer metallic gasket diameter.

---

## INTRODUCTION

---

**NOTE:** Any Loctite product can be used here. A low strength liquid is recommended as normal strength and gap are required.

- Install according to standard procedure.
- Wipe off surplus.
- Allow it to cure for 30 minutes.

**NOTE:** Normally used on worn-out housings to prevent leaking or sliding.

It is generally not necessary to remove gasket compound applied on outer gasket diameter.

## TIGHTENING TORQUES

Tighten fasteners to torque mentioned in exploded views and/or text. When they are not specified, refer to following table.

### WARNING

Torque wrench tightening specifications must strictly be adhered to. Locking devices (e.g.: locking tabs, elastic stop nuts, self-locking fasteners, etc.) must be installed or replaced with new ones, where specified. If the efficiency of a locking device is impaired, it must be renewed.

In order to avoid a poor assembling, tighten screws, bolts or nuts in accordance with the following procedure:







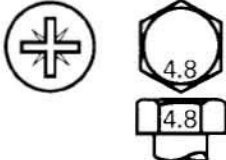

- Manually screw all screws, bolts and/or nuts.
- Apply the half of the recommended torque value.

**CAUTION:** Be sure to use the proper tightening torque for the proper strength grade.

**NOTE:** When possible, always apply torque on the nut.

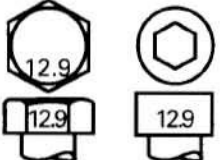
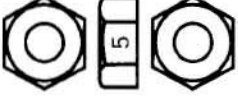
- Torque to the recommended torque value.

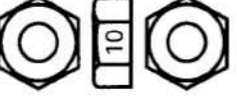
**NOTE:** Always torque screws, bolts and/or nuts in a criss-cross sequence.

Property class and head markings					
Property class and nut markings					

FASTENER SIZE	FASTENER GRADE/TORQUE			
	5.8 Grade	8.8 Grade	10.9 Grade	12.9 Grade
M4	1.5 – 2 N•m (13 – 18 lbf•in)	2.5 – 3 N•m (22 – 27 lbf•in)	3.5 – 4 N•m (31 – 35 lbf•in)	4 – 5 N•m (35 – 44 lbf•in)
M5	3 – 3.5 N•m (27 – 31 lbf•in)	4.5 – 5.5 N•m (40 – 47 lbf•in)	7 – 8.5 N•m (62 – 75 lbf•in)	8 – 10 N•m (71 – 89 lbf•in)
M6	6.5 – 8.5 N•m (58 – 75 lbf•in)	8 – 12 N•m (71 – 106 lbf•in)	10.5 – 15 N•m (93 – 133 lbf•in)	16 N•m (142 lbf•in)
M8	15 N•m (11 lbf•ft)	24.5 N•m (18 lbf•ft)	31.5 N•m (23 lbf•ft)	40 N•m (30 lbf•ft)
M10	29 N•m (21 lbf•ft)	48 N•m (35 lbf•ft)	61 N•m (45 lbf•ft)	72.5 N•m (53 lbf•ft)
M12	52 N•m (38 lbf•ft)	85 N•m (63 lbf•ft)	105 N•m (77 lbf•ft)	127.5 N•m (94 lbf•ft)
M14	85 N•m (63 lbf•ft)	135 N•m (100 lbf•ft)	170 N•m (125 lbf•ft)	200 N•m (148 lbf•ft)



**Section 01 MAINTENANCE**  
Subsection 01 (MAINTENANCE CHART)

# MAINTENANCE CHART

The schedule should be adjusted according to operating conditions and use.

**NOTE:** The chart gives an equivalence between number of hours and months/year. Perform the maintenance operation to whatever time comes first.

**IMPORTANT:** Watercraft rental operations or intensive use of watercraft, will require greater frequency of inspection and maintenance.

<b>4-TEC MODELS</b>						
<b>A: ADJUST</b> <b>C: CLEAN</b> <b>I: INSPECT</b> <b>L: LUBRICATE</b> <b>R: REPLACE</b>	<b>FIRST 10 HOURS</b>					
	<b>EVERY 25 HOURS OR 3 MONTHS</b>					
	<b>EVERY 50 HOURS OR 6 MONTHS</b>					
	<b>EVERY 100 HOURS OR 1 YEAR</b>					
	<b>EVERY 200 HOURS OR 2 YEAR</b>					
PART/TASK					REFER TO	
<b>GENERAL</b>						
Corrosion protection			L		STORAGE PROCEDURE	
<b>ENGINE</b>						
Engine oil and filter (including cover's O-rings)	R			R <sup>(1)</sup>	LUBRICATION SYSTEM	
Rubber mounts	I			I	ENGINE REMOVAL AND INSTALLATION	
Exhaust system fasteners <sup>(2)</sup>	I			I	EXHAUST SYSTEM	
Exhaust system flushing				<sup>(3)</sup> <sup>(7)</sup>		
Supercharger slipping moment (if so equipped)				I	SUPERCHARGER	
<b>COOLING SYSTEM</b>						
Hose and fasteners	I				COOLING SYSTEM	
Coolant	I			R		
<b>FUEL SYSTEM</b>						
Throttle cable	I			I <sup>(5)</sup>	ENGINE MANAGEMENT	
Fuel injection system sensors	I			I		
Throttle position sensor (TPS) <sup>(2)</sup>	I			I		
Throttle body (IMPORTANT: see <sup>(4)</sup> )	I			L	ENGINE MANAGEMENT and STORAGE PROCEDURES	
Fuel lines, connections, pressure relief valve and fuel system leak test <sup>(2)</sup>	I			I	FUEL TANK AND FUEL PUMP	
Fuel tank straps	I			I		
<b>AIR INTAKE SYSTEM</b>						
Air intake silencer fit/tightness	I			I	AIR INTAKE SYSTEM	
<b>ELECTRICAL SYSTEM</b>						
Spark plug <sup>(2)</sup>	I			I	R	IGNITION SYSTEM
Electrical connections and fastening (ignition system, starting system, fuel injectors etc.)	I			I		ELECTRICAL SYSTEM
MPEM and ECM connectors (visual inspection without disconnecting)				I <sup>(6)</sup>		ENGINE MANAGEMENT
EMS fault code reading <sup>(2)</sup>	I			I		DIGITALLY ENCODED SECURITY SYSTEM
Digitally Encoded Security System (DESS) and safety lanyard/post	I			I		
Monitoring beeper	I			I		GAUGE, SENSORS AND FUSES
Battery and fasteners	I			I		CHARGING SYSTEM

**Section 01 MAINTENANCE**  
**Subsection 01 (MAINTENANCE CHART)**

4-TEC MODELS						
A: ADJUST C: CLEAN I: INSPECT L: LUBRICATE R: REPLACE	FIRST 10 HOURS					
	EVERY 25 HOURS OR 3 MONTHS					
	EVERY 50 HOURS OR 6 MONTHS					
	EVERY 100 HOURS OR 1 YEAR					
	EVERY 200 HOURS OR 2 YEAR					
PART/TASK						REFER TO
<b>STEERING SYSTEM</b>						
Steering cable and connections	I			I		STEERING SYSTEM
Steering nozzle bushings	I			I		
Off-power assisted steering (O.P.A.S.)	I			I		OFF-POWER ASSISTED STEERING SYSTEM (O.P.A.S.)
Off-power assisted steering filter (if applicable)		I <sup>(6)</sup>				
<b>PROPULSION SYSTEM</b>						
Drive shaft corrosion protection <sup>(5)</sup>				L <sup>(7)</sup>		DRIVE SYSTEM
Carbon ring and rubber boot (drive shaft)	I			I		
Reverse system, cable and connections	I			I		REVERSE SYSTEM
VTS (Variable Trim System) (if so equipped)	I			I		VARIABLE TRIM SYSTEM
Drive shaft/impeller splines				I, L		JET PUMP and DRIVE SYSTEM
Impeller boot	I			I		JET PUMP
Impeller shaft seal, sleeve and O-ring				I <sup>(7)</sup>		
Impeller and wear ring clearance	I			I		
Sacrificial anode					I <sup>(8)</sup>	
<b>HULL/BODY</b>						
Ride plate and water intake grate	I			I		HULL AND BODY
Drain plugs (inside bilge), check for obstructions	I			I		
Hull	I			I		
Ski/wakeboard post and fasteners	I			I		

- (1) Replace for storage period or after 100 hours of use whichever comes first.
- (2) Emission-related component.
- (3) Daily flushing in salt water or foul water use.
- (4) **IMPORTANT:** When use in salt water, the throttle body lubrication is highly recommended after every 10 hours of use. Failure to perform lubrication will result in damage to the throttle body.
- (5) In salt water use.
- (6) Every 25 hours when riding in weed area.
- (7) Perform at storage period or after 100 hours of use whichever comes first.
- (8) Inspect each month (more often in salt water) and change when necessary.

# PRESEASON PREPARATION

Proper vehicle preparation is necessary after the winter months or when a vehicle has not been used during several weeks.

Any worn, broken or damaged parts found during the storage procedure should have been replaced. If not, proceed with the replacement.

**⚠ WARNING**

Unless otherwise specified, engine should be turned off during preseason preparation procedure.

PRESEASON PREPARATION	TO BE PERFORMED BY		REFER TO
	CUSTOMER	DEALER	
<b>GENERAL</b>			
Corrosion protection	✓		STORAGE PROCEDURE
<b>ENGINE</b>			
Exhaust system condition and fasteners		✓	EXHAUST SYSTEM
Oil level <sup>(1)</sup>		✓	LUBRICATION SYSTEM
<b>COOLING SYSTEM</b>			
Coolant level <sup>(2)</sup>		✓	COOLING SYSTEM
Hoses and fasteners		✓	
<b>FUEL SYSTEM</b>			
Fuel injection sensors verification		✓	ENGINE MANAGEMENT
Inspection of check valves, lines, fasteners and fuel system leak test		✓	FUEL TANK AND FUEL PUMP
Filler neck, fuel tank and fuel cap condition		✓	
Fuel tank straps		✓	
Refill fuel tank	✓		Refer to the appropriate OPERATOR'S GUIDE
<b>ELECTRICAL SYSTEM</b>			
Spark plugs <sup>(3)</sup>		✓	IGNITION SYSTEM
Battery condition/charging and installation		✓	CHARGING SYSTEM
Connection and routing of electric harness (battery, starter, etc.)		✓	ELECTRICAL SYSTEM
Digitally Encoded Security System (DESS) and monitoring beeper verification		✓	GAUGE, SENSORS AND FUSES
<b>STEERING SYSTEM</b>			
Steering system adjustment and inspection		✓	STEERING SYSTEM
Check O.P.A.S. condition		✓	OFF-POWER ASSISTED STEERING



## Section 01 MAINTENANCE

### Subsection 02 (PRESEASON PREPARATION)

PRESEASON PREPARATION	TO BE PERFORMED BY		REFER TO
	CUSTOMER	DEALER	
<b>PROPULSION SYSTEM</b>			
Shifter system condition and cable adjustment		✓	REVERSE SYSTEM
Variable Trim System (VTS) condition (if so equipped)		✓	VTS SYSTEM
Propulsion system inspection		✓	JET PUMP and DRIVE SYSTEM
<b>HULL and BODY</b>			
Inspection of bilge drain plugs		✓	HULL/BODY
Ski/wakeboard post and fasteners (if so equipped)	✓		

- (1) If oil and filter were not replaced at storage, proceed with oil change.
- (2) If antifreeze was not changed at storage, drain and replace with new antifreeze.
- (3) Replace every 200 hours or 2 years.

# STORAGE PROCEDURES

## SERVICE PRODUCTS

Description	Part Number	Page
anticorrosion spray .....	219 700 304 .....	7
BRP fuel stabilizer.....	413 408 600 .....	5
Loctite 243 (blue).....	293 800 060 .....	7
XP-S Lube .....	293 600 016 .....	5-7

## PROPULSION SYSTEM

### Jet Pump

Clean jet pump by spraying water in its inlet and outlet and then apply a coating of XP-S Lube (P/N 293 600 016) or equivalent.

**⚠ WARNING**

Always remove safety lanyard cap from post to prevent unexpected engine starting before cleaning the jet pump area. Engine must not be running for this operation.

Remove cone and check if jet pump is water contaminated; if so, refer to *JET PUMP* for the repair procedure.

## FUEL SYSTEM

Verify fuel system. Check fuel hoses for leaks. Replace damaged hoses or clamps if necessary.

### Fuel Stabilizer

BRP fuel stabilizer (P/N 413 408 600) or equivalent should be added in fuel tank to prevent fuel deterioration and fuel system gumming. Follow manufacturer's instructions for proper use.

**CAUTION:** Fuel stabilizer should be added prior to engine lubrication to ensure fuel system components protection against varnish deposits.

Fill up fuel tank completely. Ensure there is no water inside fuel tank.

**CAUTION:** Should any water be trapped inside fuel tank, severe internal damage will occur to the fuel injection system.

**⚠ WARNING**

Fuel is inflammable and explosive under certain conditions. Always work in a well ventilated area. Do not smoke or allow open flames or sparks in the vicinity. Fuel tank may be pressurized, slowly turn cap when opening. When fueling, keep watercraft level. Do not overfill or top off the fuel tank and leave watercraft in the sun. As temperature increases, fuel expands and might overflow. Always wipe off any fuel spillage from the watercraft. Periodically inspect fuel system.

### Throttle Body

It is recommended to lubricate the throttle body to prevent corrosion on external and internal parts especially if the watercraft is used in salt water.

#### **Models Equipped with Lubrication Fitting**

Use fitting for that purpose provided in the engine compartment.

Make sure to spray XP-S Lube (P/N 293 600 016) at least 3 to 5 seconds for proper lubrication.

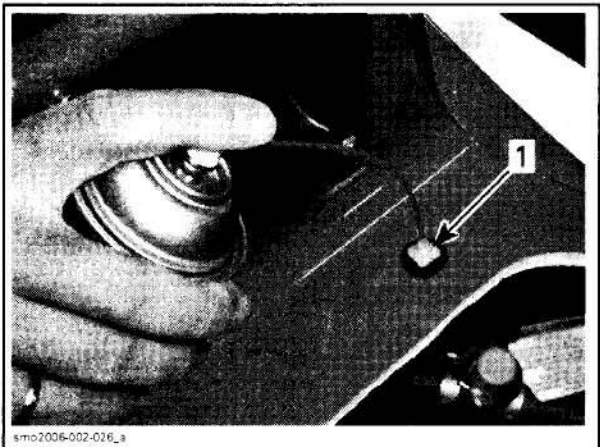

smo2006-002-026\_a

GTI MODELS — TYPICAL  
1. Fitting

## Section 01 MAINTENANCE

### Subsection 03 (STORAGE PROCEDURES)

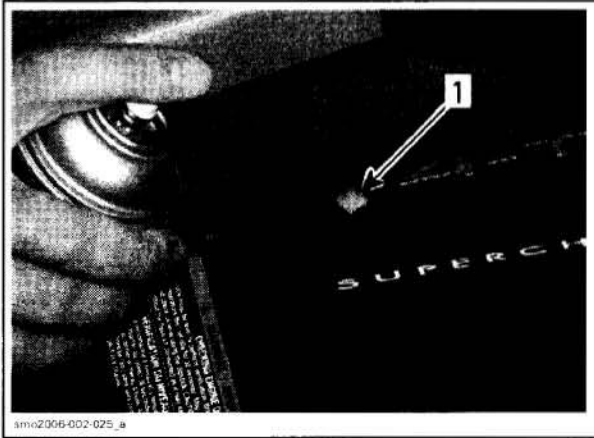

OTHER MODELS — ENGINE COVER  
1. Fitting

#### Models without Lubrication Fitting

Remove the air intake hose from throttle body.

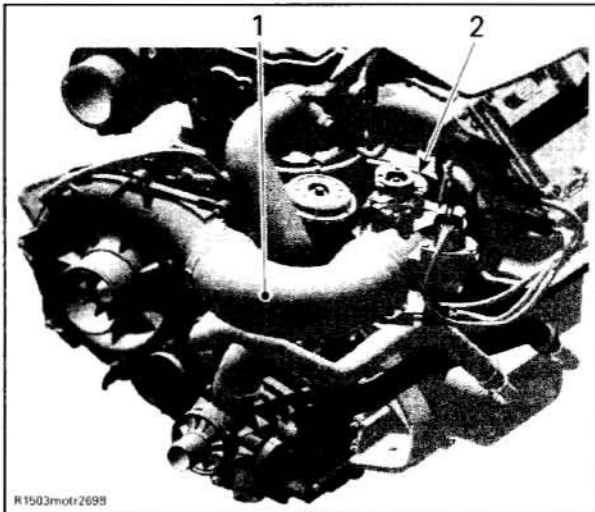

TYPICAL  
1. Air intake hose  
2. Throttle body

Open the throttle body valve by pressing slightly the throttle lever.

Spray XP-S Lube (P/N 293 600 016) through the throttle body bore to lubricate valve mechanism.

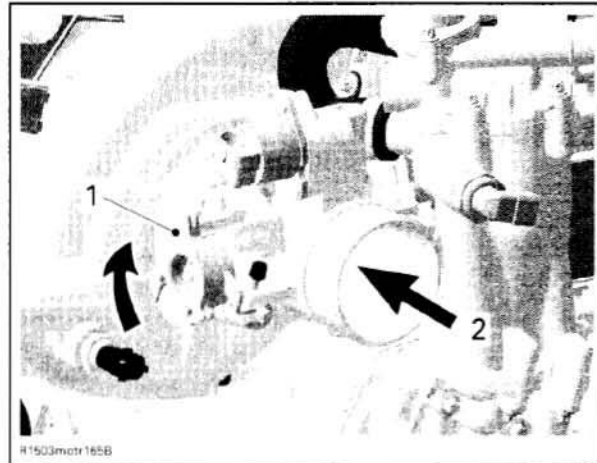

TYPICAL  
1. Open throttle body valve  
2. Lubricate valve mechanism

Reinstall air intake hose.

## ENGINE

### Engine Oil and Filter

Change engine oil and filter. Refer to *LUBRICATION SYSTEM* in *ENGINE* section.

### Exhaust System

Flush the exhaust system. Refer to *EXHAUST SYSTEM*.

### Engine Coolant

Antifreeze should be replaced for the storage period to prevent antifreeze deterioration.

Make sure to perform an antifreeze density test.

For the coolant replacement procedure, refer to *COOLING SYSTEM*.

**CAUTION:** Improper antifreeze mixture might allow freezing of the liquid in the cooling system if vehicle is stored in area where freezing point is reached. This would seriously damage the engine. Failure to replace the antifreeze for storage may allow its degradation that could result in poor cooling when engine will be used.

### Engine Fogging

Engine must be lubricated to prevent corrosion on internal parts.

Fogging of the engine is recommended at the end of the season and before any extended storage period to provide additional corrosion protection. This will lubricate the engine intake valves, the cylinders and the exhaust valves.



---

## Section 01 MAINTENANCE

### Subsection 03 (STORAGE PROCEDURES)

---

To fog the engine, proceed as follows:

- Remove the two bolts that hold the fuel rail on.
- Remove the rail along with the three fuel injectors.
- Spray liberally XP-S Lube (P/N 293 600 016) into the intake ports.
- Crank engine several times while keeping throttle fully depressed (drown engine mode) to distribute lubricant in cylinders, on intake valves and exhaust valves.
- Carefully inspect O-rings condition before re-installing fuel injectors. Replace O-rings with new ones if damaged. Lubricate O-rings with injection oil prior to installing.
- Reinstall the injectors.
- Apply Loctite 243 (blue) (P/N 293 800 060) and torque the two bolts to 9 N•m (80 lbf•in) that hold the fuel rail on.
- Make sure there is no leak at injectors when cranking the engine in the upcoming steps.

#### WARNING

If a leak is present, immediately stop the engine. Do not start engine until the leak is repaired.

#### WARNING

At preseason preparation, ensure to perform a fuel pressure test and ensure there is no leak. Also run engine and check for leaks. Refer to *FUEL TANK AND FUEL PUMP* section.

### Intercooler and Exhaust Manifold

#### *Supercharged Intercooled Models*

The exhaust system is self draining, but the intercooler and manifold need the following protection.

- Remove both intercooler hoses.
- Let the intercooler drain, then connect the bottom hose.
- Pour approximately 200 mL (6.76 oz U.S.) of antifreeze into the intercooler.
- Then pour approximately 300 mL (10.14 oz U.S.) of antifreeze into the exhaust manifold.
- Reconnect the upper hose.

**CAUTION:** It is highly recommended to pour antifreeze into the intercooler and exhaust manifold. Failure to do so, may cause severe damage to these components.

**CAUTION:** Use only undiluted antifreeze (100% concentration). The premixed antifreeze available from BRP is NOT suitable for this particular application. Its concentration will be reduced when mixed with remaining water trapped in water jackets.

**NOTE:** When available, it is recommended to use biodegradable antifreeze compatible with internal combustion aluminum engines. This will contribute to protect the environment.

**NOTE:** The engine will not have to run during this operation but should have been ran before, to exhaust as much water as possible, from cooling system components.

## ELECTRICAL SYSTEM

### Battery

For battery removal, cleaning and storage, refer to *CHARGING SYSTEM*.

## VEHICLE

### Cleaning

Clean the bilge with hot water and mild detergent or with bilge cleaner. Rinse thoroughly. Lift front end of watercraft to completely drain bilge. If any repairs are needed to body or to the hull, touch up paint and Gelcote® repair kit are available. Replace damaged labels/decals.

Wash the body with soap and water solution (only use mild detergent). Rinse thoroughly with fresh water. Remove marine organisms from the hull. Apply a nonabrasive wax.

**CAUTION:** Never clean fiberglass and plastic parts with strong detergent, degreasing agent, paint thinner, acetone, etc.

### Anticorrosion Treatment

Wipe off any residual water in the engine compartment.

Spray XP-S Lube (P/N 293 600 016) over all metallic components in engine compartment.

If the vehicle is used in salt water, apply the anti-corrosion spray (P/N 219 700 304) on drive shaft. Refer to *DRIVE SYSTEM*.

### Vehicle Protection

The seat should be partially left opened during storage. This will avoid engine compartment condensation and possible corrosion.

---

## Section 01 MAINTENANCE

### Subsection 03 (STORAGE PROCEDURES)

---

If the watercraft is to be stored outside, cover it with an opaque tarpaulin to prevent sun rays and grime from affecting the plastic components, watercraft finish as well as preventing dust accumulation.

**CAUTION:** The watercraft must never be left in water for storage. Never leave the watercraft stored in direct sunlight.

## CHECKLIST

OPERATION	✓
Verify jet pump (water contamination).	
Verify fuel system.	
Add fuel stabilizer.	
Fill up fuel tank.	
Change engine oil and filter.	
Flush exhaust system.	
Replace antifreeze.	
Fog the engine.	
Lubricate throttle body.	
Add antifreeze into intercooler and exhaust manifold (where temperatures are below freezing).	
Remove, clean and store the battery.	
Clean the bilge.	
Wash the body.	
Spray XP-S Lube (P/N 293 600 016) over all metallic components in engine compartment.	
Apply the anticorrosion spray (P/N 219 700 304) on drive shaft (salt water use).	
Partially lift the seat.	

# SPECIAL PROCEDURES

## SERVICE TOOLS

Description	Part Number	Page
large hose pincher .....	529 032 500 .....	9
pump .....	529 035 880 .....	10

## TOWING THE WATERCRAFT IN WATER

Special precautions should be taken when towing a Sea-Doo watercraft in water.

Maximum recommended towing speed is 24 km/h (15 MPH).

When towing your watercraft in water, pinch the water supply hose from the jet pump housing to the engine with a large hose pincher (P/N 529 032 500).

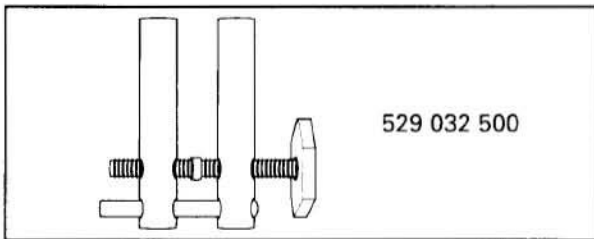

This will prevent the exhaust cooling system from filling which may lead to water being injected into and filling the exhaust system and the engine. Without the engine running there isn't any exhaust pressure to carry the water out the exhaust outlet.

**CAUTION:** Failure to do this may result in damage to the engine. If you must tow a stranded watercraft in water and do not have a hose pincher be sure to stay well below the maximum towing speed of 24 km/h (15 MPH).

Snugly install the hose pincher on the water supply hose as shown in the following illustrations.

**NOTE:** Pinch the hose with the red tape (if so equipped).

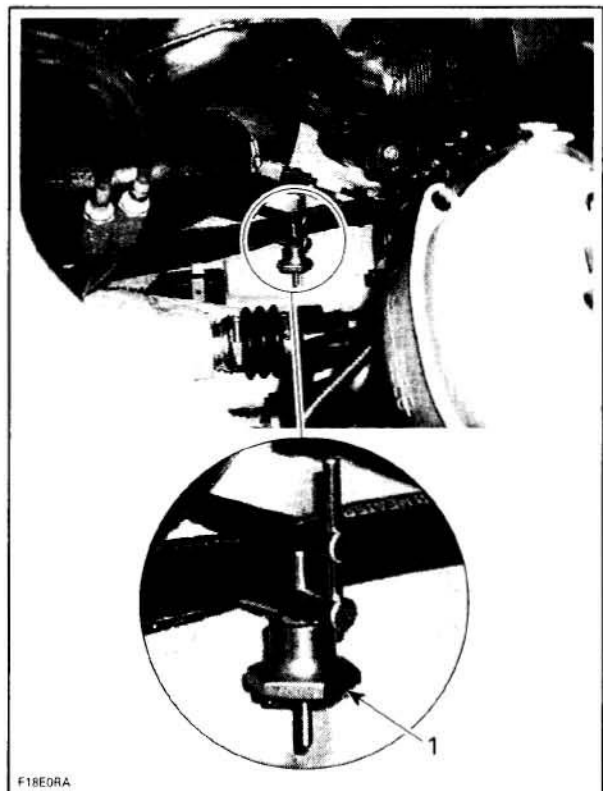

TYPICAL  
1. Hose pincher

**CAUTION:** When finished towing the watercraft, the hose pincher must be removed before operating it.

## SUBMERGED WATERCRAFT

Drain bilge.

If it was submerged in salt water, spray bilge and all components with fresh water using a garden hose to stop the salt corroding effect.

### Engine

Refer to *WATER-FLOODED ENGINE* in this section.



## Fuel System

Check fuel reservoir for water contamination. If necessary, siphon and refill with fresh fuel.

## WATER-FLOODED ENGINE

If engine is water-flooded, it must be serviced within a few hours after the event. Otherwise engine will have to be overhauled.

**CAUTION:** Never try to crank or start the engine. Water trapped in the intake manifold would enter the combustion chamber through the intake valves and may cause damage to the engine.

**CAUTION:** A water-flooded engine must be properly drained, lubricant replaced (oil change), operated (boil out procedure), then lubricant replaced again, otherwise parts will be seriously damaged.

Whenever the engine is stopped, all the valves close thus preventing water from being ingested in the engine.

If water is suspected to be in the intake and the exhaust system, it must be drained as follows:

- Remove the intake manifold and drain it. Then suck out the water from the intake valve ports. Refer to *INTAKE MANIFOLD AND INTER-COOLER*.
- Remove the water from oil/air separator breather hose.
- Remove the exhaust pipe and drain it. Then either remove the mufflers to drain them or siphon the water out of them. Refer to *EXHAUST SYSTEM*.
- If water gets in the oil (oil will be milky), change the engine oil and filter as per procedure further in this subsection.

## Throttle Body

Throttle body should be lubricated to prevent corrosion. Refer to *STORAGE PROCEDURES*.

## Supercharger

### Supercharged 4-TEC Engines

If there was water in the oil or in the intake manifold, it is recommended to take the supercharger apart, dry all the components, replace the slip clutch needle bearings and shaft ball bearings. Refer to *SUPERCHARGER*.

## Oil Change Procedure (water-contaminated oil)

- Using the pump (P/N 529 035 880), siphon the contaminated oil from the engine reservoir through dipstick hole.

**CAUTION:** Never crank or start engine when siphon tube is in dipstick hole. Never start engine when there is no oil in engine.

- Remove the pump from the dipstick hole.
- While in drowned engine mode, crank the engine for 5 seconds.
- Remove the oil filter cap and the oil filter.
- Again, siphon the contaminated oil from the reservoir.
- Remove valve cover. Refer to *CYLINDER HEAD*.

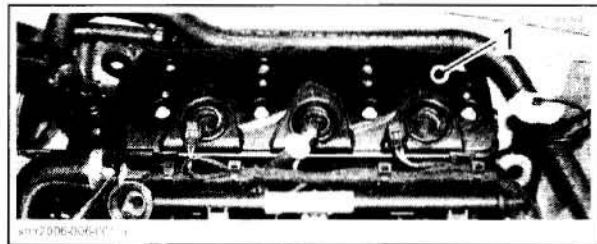

1 Valve cover

- The contaminated oil in the PTO area of the engine is siphoned using the same pump as above.
- Put a tape at 400 mm (16 in) from the end of the pump tube.
- Insert the tube in the PTO area until the tape reach the cylinder-block edge. Then, siphon contaminated oil out.

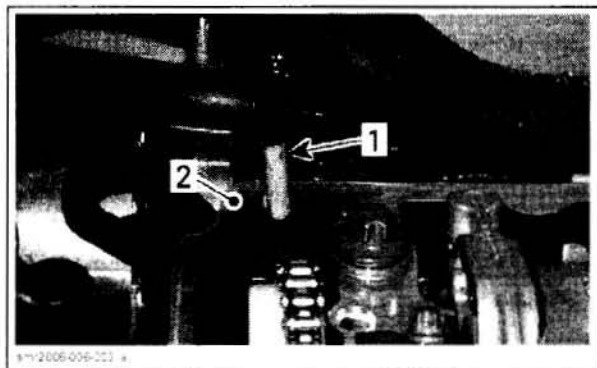

### TYPICAL

- 1 Pump tube with tape
- 2 Edge of cylinder-block

- Remove the pump tube.
- Reinstall valve cover.
- Install a new oil filter and reinstall the oil filter cap.

## Section 01 MAINTENANCE

### Subsection 04 (SPECIAL PROCEDURES)

- Fill up the reservoir with fresh oil.
- Proceed with the boil out procedure below.

#### Boil Out Procedure

**NOTE:** This procedure is intended to evaporate the water contained in the oil. The procedure with the watercraft in water is the preferred one, but it can also be done using the flush kit.

#### Procedure in a Test Tank or Tied to a Trailer with Watercraft in Water

- Connect the vehicle to B.U.D.S. to monitor the coolant temperature. It must exceed 100°C (212°F) in order for the water boil out. Once the boil point is reached, it won't take long to evaporate the water.
- Run the engine for 5 minutes at 3500 RPM.

#### **⚠ WARNING**

Make sure to safely secure the watercraft.

- With the engine still running at 3500 RPM, install a hose pincher to the coolant line going to the oil cooler.

#### **⚠ WARNING**

Certain components in the engine compartment may be very hot. Direct contact may result in skin burn. Do not touch any electrical parts or jet pump area when engine is running.

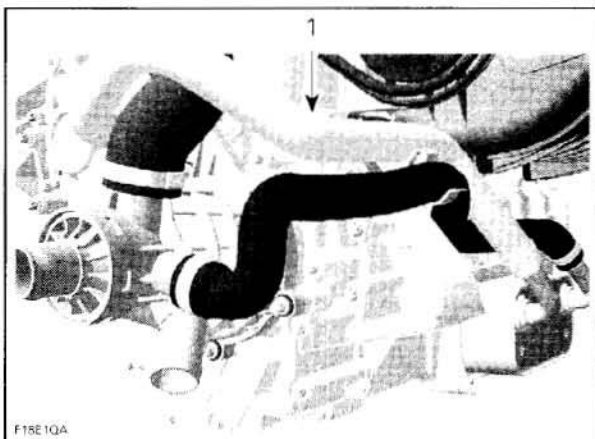

1. Oil cooler coolant inlet hose

- Continue to run the engine at 3500 RPM for 15 more minutes (20 minutes total run time).
- Shut the engine off.
- Remove the hose pincher on the coolant line going to the oil cooler.

**CAUTION:** Hose pincher must be removed prior to operating the watercraft. Failure to do this will result in damage to the engine.

- Change the oil and filter again.
- Procedure is now completed.

#### Procedure Connected to a Flush Kit

- On drive shaft, remove the C-clip then move forward the ring seal carrier. Refer to *DRIVE SYSTEM* section.

**CAUTION:** Make sure that the ring seal carrier is not in contact with the PTO seal assembly, neither with the carbon ring.

- Connect the vehicle to B.U.D.S. to monitor the coolant temperature. It must exceed 100°C (212°F) in order for the water boil out. Once the boil point is reached, it won't take long to evaporate the water.
- Connect a flush kit to the coolant line.

**CAUTION:** Never run engine without supplying water to the exhaust cooling system when watercraft is out of water.

- Run the engine for 5 minutes at 3000 RPM.
- With the engine still running at 3000 RPM, install a hose pincher to the coolant line going to the oil cooler.

#### **⚠ WARNING**

Certain components in the engine compartment may be very hot. Direct contact may result in skin burn. Do not touch any electrical parts or jet pump area when engine is running.

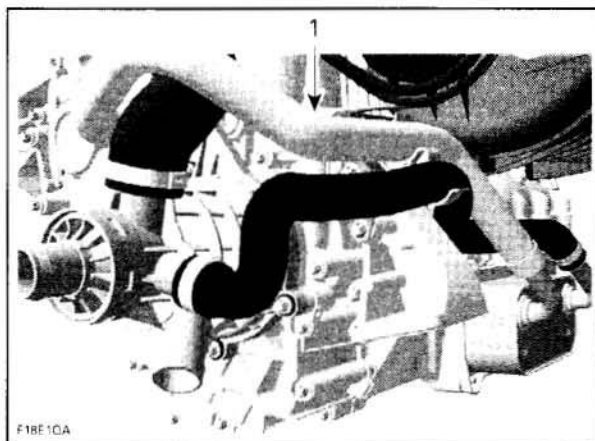

1. Oil cooler coolant inlet hose

- Continue to run the engine at 3000 RPM for 15 more minutes (20 minutes total run time).
- Shut off the engine.

---

## Section 01 MAINTENANCE

### Subsection 04 (SPECIAL PROCEDURES)

---

- Remove the hose pincher on the coolant line going to the oil cooler.

**CAUTION:** Hose pincher must be removed prior to operating the watercraft. Failure to do this will result in damage to the engine.

- Change the oil and filter again.
- Move rearward the ring seal carrier and reinstall the C-clip. Refer to *DRIVE SYSTEM* section.



# TROUBLESHOOTING CHART

The following is provided to help in diagnosing the probable source of troubles. It is a guideline and should not be assumed to show all causes for all problems.

Prior to replacing an ECM or MPEM, refer to the appropriate ECM/MPEM section or ECM/MPEM replacement in the *ENGINE MANAGEMENT* section and read carefully the tests to do before replacing an ECM/MPEM that could otherwise be good.

Always check for fault codes. If a fault code is detected, service the fault code and recheck operating conditions. Refer to *EMS DIAGNOSTIC AND COMMUNICATIONS TOOLS* in *ENGINE MANAGEMENT* section.

## ENGINE

Symptom: **ENGINE WILL NOT START (engine does not turn over)**

- 1. Wrong safety lanyard**
  - Use one that has been programmed.
- 2. DESS operation non functional**
  - If 2 short beeps are not heard when installing safety lanyard, refer to DIGITALLY ENCODED SECURITY SYSTEM.
- 3. Safety lanyard switch faulty or disconnected or harness damaged**
  - Replace.
- 4. Burnt fuse: battery, starting system. Also fuel pump**
  - Check wiring then replace fuse.
- 5. Starting system fuse keeps on burning**
  - Check wiring, starting system solenoid and MPEM.
- 6. Discharged or disconnected battery**
  - Check/recharge. Refer to CHARGING SYSTEM.
- 7. Defective or disconnected start/stop switch**
  - Check, refer to STARTING SYSTEM.
- 8. Battery connections**
  - Check/clean/tighten.
- 9. Poor/bad or corroded ground contacts (engine, starter etc.)**
  - Check/clean/repair.
- 10. Water/fuel hydro-lock**
  - Check, refer to MAINTENANCE.
- 11. Starter malfunction**
  - Check, refer to STARTING SYSTEM.
- 12. Starter solenoid**
  - Check, refer to STARTING SYSTEM.
- 13. Obstructed starter drive gear assembly**
  - Check/repair, refer to PTO HOUSING AND MAGNETO.
- 14. Seized or obstructed engine**
  - Check/repair, refer to the ENGINE.
- 15. Seized or obstructed supercharger (if so equipped)**
  - Check/repair, refer to SUPERCHARGER.

## Section 02 TROUBLESHOOTING

### Subsection 01 (TROUBLESHOOTING CHART)

---

Symptom: **ENGINE WILL NOT START (engine does not turn over)** (cont'd)

---

- 16. Seized jet pump**
  - Check, refer to PROPULSION SYSTEM.
- 17. Faulty sensor, ECM or MPEM**
  - Check fault codes, refer to ENGINE MANAGEMENT.

Symptom: **ENGINE WILL NOT START (engine turns slowly)**

---

- 1. Loose battery cables**
  - Check/clean/tighten.
- 2. Discharged/weak battery**
  - Check/charge/replace.
- 3. Restriction in jet pump**
  - Check/clean pump.
- 4. Partial seizure in jet pump**
  - Inspect, refer to PROPULSION SYSTEM.
- 5. Partial engine hydro-lock**
  - Check, refer to MAINTENANCE.
- 6. Partial engine seizure**
  - Check compression, refer to ENGINE sections.
- 7. Worn starter**
  - Check, refer to STARTING SYSTEM.
- 8. Timing chain not guided by chain guide**
  - Check, refer to CYLINDER HEAD and CYLINDER BLOCK.
- 9. Outside temperature too low**
  - Oil is too thick. Change oil viscosity.
  - Battery capacity is not sufficient for cold temperature.

Symptom: **ENGINE WILL NOT START (engine turns over)**

---

- 1. Faulty component in the fuel injection system**
  - Check for fault codes. Refer to EMS DIAGNOSTIC AND COMMUNICATION TOOLS in ENGINE MANAGEMENT.
- 2. Engine drowned mode is active**
  - Release throttle lever.
- 3. Low battery voltage**
  - Recharge or replace battery.
- 4. Wrong info-center**
  - Remove and install the recommended info-center for the vehicle.
- 5. Low or no fuel pressure**
  - Check fuel pump pressure output.
  - Check fuel pump fuse.
  - Check wiring harness.
- 6. Fuel injectors not working**
  - Check fuel injector operation. Replace as necessary.
  - Check output signal from MPEM.

---

**Section 02 TROUBLESHOOTING**  
Subsection 01 (TROUBLESHOOTING CHART)

---

Symptom: **ENGINE WILL NOT START (engine turns over)** (cont'd)

---

- 7. Defective MPEM or ECM**
  - Check ignition system and repair.
  - Replace MPEM or ECM (as applicable).
- 8. Defective CPS**
  - Check operation of CPS and replace if necessary.
- 9. Water-contaminated fuel**
  - Check/siphon and refill.
- 10. Dirty fuel filter**
  - Clean/replace.
- 11. Fouled or defective spark plug**
  - Replace.
- 12. Water in engine**
  - Check, refer to MAINTENANCE.
- 13. Defective ignition circuit**
  - Check, refer to IGNITION SYSTEM.
- 14. Internal engine damage**
  - Check, refer to ENGINE sections.
- 15. Defective encoder/trigger wheel**
  - Check, refer to ENGINE MANAGEMENT.
- 16. Incorrectly aligned flywheel and trigger wheel**
  - Properly position flywheel and trigger wheel, refer to PTO HOUSING AND MAGNETO.
- 17. Insufficient engine compression**
  - Replace defective part(s).
- 18. Idle bypass valve stuck or not functioning**
  - Check, refer to ENGINE MANAGEMENT.

Symptom: **ENGINE WILL NOT START (no spark at spark plugs)**

---

- 1. Spark plug faulty, fouled or worn out**
  - Check spark plug condition. Replace if necessary.
- 2. Defective ignition circuit**
  - Check, refer to IGNITION SYSTEM.
- 3. Faulty ECM**
  - Replace ECM.

Symptom: **ENGINE HARD TO START**

---

- 1. Defective idle bypass valve**
  - Refer to ENGINE MANAGEMENT.
- 2. Wrong TPS zero setting**
  - Refer to ENGINE MANAGEMENT.
- 3. Throttle cable adjustment**
  - Refer to ENGINE MANAGEMENT.



---

## Section 02 TROUBLESHOOTING

### Subsection 01 (TROUBLESHOOTING CHART)

---

Symptom: **ENGINE HARD TO START** (cont'd)

---

- 4. Temperature too low for available battery capacity**
  - *Battery capacity is not sufficient for cold temperature.*
- 5. Air lock in fuel rail**
  - *Refer to ENGINE MANAGEMENT.*
- 6. Water in intake system (defective MAP sensor)**
  - *Check and remove water. Refer to SPECIAL PROCEDURES subsection.*
- 7. Water in fuel reservoir or contaminated fuel**
  - *Flush reservoir and refill with fresh gas.*
- 8. Mechanical engine failure**
  - *Check cylinder compression.*
  - *Check for cylinder head leaks.*
  - *Check starting system.*
- 9. Spark plug faulty, fouled or worn out**
  - *Check spark plug condition. Replace if necessary.*
- 10. Low fuel pressure**
  - *Check fuel pump operation. Refer to FUEL TANK AND FUEL PUMP.*
  - *Check fuel pressure regulator. Refer to FUEL TANK AND FUEL PUMP.*
- 11. Defective CAPS**
  - *Check CAPS and its circuit. Refer to ENGINE MANAGEMENT.*

Symptom: **ENGINE STARTS BUT RUNS ONLY AT IDLE SPEED**

---

- 1. The system is in limp home mode**
  - *Refer to ENGINE MANAGEMENT and check the fault codes.*
- 2. Broken or loose throttle cable**
  - *Change/readjust.*

Symptom: **ENGINE MISFIRES, RUNS IRREGULARLY**

---

- 1. Fouled, defective, worn spark plugs**
  - *Check/verify heat range/gap/replace.*
- 2. Faulty ECM or MPEM**
  - *Check, refer to ENGINE MANAGEMENT.*
- 3. Defective trigger wheel/CPS**
  - *Check, refer to ENGINE MANAGEMENT.*
- 4. Defective ignition circuit**
  - *Check coil, wiring condition and proper grounding of ignition coil.*
- 5. Poor engine ground**
  - *Check/clean/repair.*
- 6. Fuel pressure (low or high)**
  - *Check pump, regulator, injectors and hose pinchers or if filter is plugged. Replace if necessary.*
- 7. Stale or water fouled fuel**
  - *Check/siphon and refill.*
- 8. Fuel filter dirty or restricted**
  - *Check/clean/replace.*

---

**Section 02 TROUBLESHOOTING**  
Subsection 01 (TROUBLESHOOTING CHART)

---

Symptom: **ENGINE MISFIRES, RUNS IRREGULARLY** (cont'd)

---

- 9. Clogged fuel injectors**  
*- Remove and clean fuel injectors.*
- 10. Defective sensor**  
*- Check faulty codes, refer to ENGINE MANAGEMENT.*
- 11. Flame arrester dirty or restricted**  
*- Check/replace.*
- 12. Faulty fuel injector(s)**  
*- Replace fuel injector(s), refer to ENGINE MANAGEMENT.*
- 13. Fuel pressure fluctuating**  
*- Inspect fuel pressure regulator. Refer to FUEL SYSTEM.*
- 14. Injector wiring reversed**  
*- Refer to the WIRING DIAGRAM.*

Symptom: **ENGINE CONTINUALLY BACKFIRES**

---

- 1. Fouled, defective spark plugs**  
*- Clean/replace.*
- 2. Ignition coil wiring reversed**  
*- Refer to WIRING DIAGRAM.*
- 3. Incorrect timing setting**  
*- Check/reset, refer to ELECTRICAL SYSTEM.*
- 4. Defective trigger wheel/CPS**  
*- Check, refer to ENGINE MANAGEMENT.*
- 5. Intake or exhaust valve(s) leak**  
*- Pressure check engine, refer to LEAK TEST.*

Symptom: **ENGINE DETONATION OR PINGING**

---

- 1. Spark plug heat range too high**  
*- Check/change to correct range.*
- 2. Engine overheats and exhaust overheats**  
*- Check, see ENGINE OVERHEATS in this section.*
- 3. Fuel octane too low or poor fuel quality**  
*- Use good quality fuel.*
- 4. Knock sensor disconnected or faulty**  
*- Check, refer to ENGINE MANAGEMENT.*
- 5. Bad ECM connection**  
*- Check, refer to ENGINE MANAGEMENT.*

Symptom: **ENGINE LACKS ACCELERATION OR POWER**

---

- 1. Weak spark**  
*- Check/replace, refer to IGNITION SYSTEM.*
- 2. Throttle does not open fully**  
*- Check/readjust, refer to ENGINE MANAGEMENT.*

---

## Section 02 TROUBLESHOOTING

### Subsection 01 (TROUBLESHOOTING CHART)

---

Symptom: **ENGINE LACKS ACCELERATION OR POWER** (cont'd)

---

- 3. Low compression**
  - Check/repair, refer to ENGINE sections.
- 4. Intake restriction**
  - Check if a restrictive gasket is installed between throttle body and intake manifold (GTI models only).
- 5. Water in fuel**
  - Check/siphon/replace.
- 6. Impeller leading edge damaged**
  - Check/replace, refer to PROPULSION SYSTEM.
- 7. Too much engine oil**
  - Siphon or adjust level. Refer to LUBRICATION SYSTEM.
- 8. Poor fuel quality**
  - Siphon then refill with fresh fuel.
- 9. Clogged fuel injectors**
  - Remove and clean fuel injectors.
- 10. Low fuel pressure**
  - Check fuel line and fuel pump pressure.
- 11. Incorrect throttle position sensor (TPS) adjustment**
  - Check and adjust TPS, refer to ENGINE MANAGEMENT.
- 12. Improper timing chain alignment**
  - Refer to CYLINDER HEAD.
- 13. Defective supercharger**
  - Check/repair, refer to SUPERCHARGER.
- 14. Dirt in supercharger due to vapor oil and salt contamination**
  - Check and clean supercharger, refer to SUPERCHARGER.
  - Check engine oil level. Siphon excess of oil.
- 15. Overheated engine**
  - See ENGINE OVERHEATS in this chart.
- 16. Limp home mode activated**
  - Refer to ENGINE MANAGEMENT.

Symptom: **ENGINE STOPS RUNNING**

---

- 1. Contaminated or inappropriate fuel**
  - Siphon reservoir and refill with fresh fuel.
- 2. Engine running out of fuel**
  - Refill fuel tank.
  - Check fuel delivery system for proper fuel pressure and delivery.
- 3. Air in fuel rail**
  - Refer to ENGINE MANAGEMENT.

Symptom: **ENGINE CANNOT REACH MAXIMUM RPM**

---

- 1. Low fuel pressure**
  - Check fuel pump pressure output.



---

**Section 02 TROUBLESHOOTING**  
Subsection 01 (TROUBLESHOOTING CHART)

---

Symptom: **ENGINE CANNOT REACH MAXIMUM RPM (cont'd)**

---

- 2. Jet pump related problem**  
*- Check propulsion components. Refer to JET PUMP.*
- 3. Limp home mode activated**  
*- Refer to ENGINE MANAGEMENT.*
- 4. Exhaust system blockage/muffler damage**  
*- Check and repair.*
- 5. Exhaust gases in bilge (leak)**  
*- Check exhaust system for leaks.*
- 6. Defective supercharger**  
*- Check/repair, refer to SUPERCHARGER.*
- 7. Dirt in supercharger due to vapor oil and salt contamination**  
*- Check and clean supercharger, refer to SUPERCHARGER.  
- Check engine oil level. Siphon excess of oil.*
- 8. Battery voltage is too low**  
*- Check/repair, refer to CHARGING SYSTEM.*

Symptom: **ENGINE RUNS TOO FAST (vehicle cannot reach its top speed)**

---

- 1. Faulty rev limiter**  
*- Check, refer to ENGINE MANAGEMENT.*
- 2. Improper impeller pitch (too low)**  
*- Check/replace, refer to PROPULSION SYSTEM.*
- 3. Damaged leading or trailing edge of impeller**  
*- Check/replace. Refer to PROPULSION SYSTEM.  
NOTE: Leading edge damage contributes to poor performance from start. Trailing edge damage contributes to poor top performance and stator vanes erosion.*
- 4. Sealing of ride plate, jet pump support or jet pump**  
*- Check/reseal, refer to section PROPULSION SYSTEM or HULL/BODY.*

Symptom: **ENGINE OVERHEATS (coolant level too low)**

---

- 1. Coolant level low**  
*- Refill/check for leaks.*
- 2. Coolant leaking out of leak indicator hole (PTO housing)**  
*- Replace seal.*
- 3. Hoses or clamps missing/defective**  
*- Repair/replace.*
- 4. Cylinder head gasket leaks (white exhaust gas)**  
*- Replace cylinder head gasket.*
- 5. Thermostat failure**  
*- Replace.*
- 6. Coolant pump failure**  
*- Replace.*
- 7. Internal passage blockage**  
*- Inspect and clean.*

---

## Section 02 TROUBLESHOOTING

### Subsection 01 (TROUBLESHOOTING CHART)

---

Symptom: **ENGINE OVERHEATS (monitoring beeper sounds continuously)**

---

- 1. Temperature sensor defective**  
- Check/replace. Refer to ENGINE MANAGEMENT.
- 2. Worn water pump impeller**  
- Check/replace.
- 3. Cooling system restriction**  
- Check/flush, refer to MAINTENANCE.
- 4. Damaged ride plate or hoses**  
- Check, refer to COOLING SYSTEM and HULL/BODY.
- 5. Thermostat defective**  
- Check/replace.

Symptom: **ENGINE SMOKE IN THE EXHAUST (white smoke)**

---

- 1. Coolant leak**  
- Check/repair. Refer to COOLING SYSTEM.
- 2. Intercooler leak (if so equipped)**  
- Check/repair. Refer to INTAKE MANIFOLD.
- 3. Damaged cylinder head gasket**  
- Check/replace cylinder head gasket.
- 4. Water ingestion**  
- Inspect intake manifold for water infiltration.
- 5. Valve stem seals**  
- Check/replace valve stem seals, refer to CYLINDER HEAD.

Symptom: **ENGINE SMOKE IN THE EXHAUST (blue smoke)**

---

- 1. Oil level too high**  
- Siphon excess of oil.
- 2. PTO oil scavenge port blocked or scavenge pump malfunction**  
- Inspect and clean or replace pump.

Symptom: **ENGINE SMOKE IN THE EXHAUST (blue smoke at engine starting)**

---

- 1. Valve stem seals worn or damaged**  
- Replace seals.
- 2. Oil rings worn out**  
- Replace rings, refer to CYLINDER BLOCK.

Symptom: **ENGINE SMOKE IN THE EXHAUST (blue smoke with engine under load)**

---

- 1. Oil rings**  
- Replace oil rings, refer to CYLINDER BLOCK.

Symptom: **LOW OR NO ENGINE OIL PRESSURE**

---

- 1. Oil level too low**  
- Refill. See TECHNICAL SPECIFICATIONS.
- 2. Leaking gasket**  
- Replace.

---

**Section 02 TROUBLESHOOTING**  
Subsection 01 (TROUBLESHOOTING CHART)

---

Symptom: **LOW OR NO ENGINE OIL PRESSURE** (cont'd)

---

- 3. Oil leaking out of leak indicator hole (PTO housing)**  
*- Replace oil seal on pump shaft.*
- 4. Oil pressure sensor defective**  
*- Check/replace.*
- 5. Oil pump malfunctioning**  
*- Clean rotor and check wear limits.*
- 6. Oil regulator valve sticks open, or spring load too small**  
*- Clean/replace.*
- 7. Heavy wear on plain bearings**  
*- Replace.*

Symptom: **ENGINE OIL CONTAMINATION (milky)**

---

- 1. Oil seal and rotary seal on coolant pump shaft leaking**  
*- Replace both seals. Refer to PTO HOUSING AND MAGNETO. Change oil.*
- 2. Cylinder head gasket leaking**  
*- Replace gasket. Refer to CYLINDER HEAD. Change oil.*
- 3. Loose screws on cylinder head, PTO housing or oil separator**  
*- Retorque. Change oil.*
- 4. Oil contamination due to metal or plastic particles**  
*- Replace possibly damaged parts. Change oil.*
- 5. Water ingestion (intake manifold, TOPS valve, dipstick)**  
*- Refer to MAINTENANCE.*
- 6. Leak indicator hole plugged**  
*- Check/clean leak indicator hole.*

Symptom: **UNUSUAL ENGINE NOISE AND/OR VIBRATION**

---

- 1. Worn chain tensioner**  
*- Replace.*
- 2. Worn chain guide**  
*- Replace.*
- 3. Stretched chain and/or worn out sprockets**  
*- Replace chain and sprockets.*
- 4. Sprocket screws got loose**  
*- Retorque.*
- 5. Hydraulic element inside rocker arm(s) is worn out (valve adjustment) or lifter damaged**  
*- Replace faulty rocker arm(s) and/or lifters.*
- 6. Rocker arm screws not tightened**  
*- Retorque.*
- 7. Heavy wear on crankshaft and/or balancer shaft bearings**  
*- Replace.*
- 8. Crankshaft and balancer shaft not aligned**  
*- Check marks and readjust shafts*



---

## Section 02 TROUBLESHOOTING

### Subsection 01 (TROUBLESHOOTING CHART)

---

Symptom: **UNUSUAL ENGINE NOISE AND/OR VIBRATION** (cont'd)

---

9. **Heavy wear on thrust washers, or thrust washers missing**
  - Check/replace.
10. **Defective supercharger (if so equipped)**
  - Check/repair, refer to SUPERCHARGER.
11. **Missing/defective air intake hose**
  - Check/replace air intake hose or clamps, refer to AIR INTAKE SYSTEM.

## STARTING SYSTEM

Symptom: **STARTER DOES NOT TURN**

---

1. **Burnt fuse**
  - Check wiring condition and replace fuse.
2. **Poor contact of battery terminal(s)**
  - Clean and tighten terminal(s).
3. **Poor battery ground cable connection**
  - Clean and tighten.
4. **Weak battery**
  - Recharge or replace battery.
5. **Poor contact of start/stop switch, safety lanyard switch or solenoid**
  - Check connectors and clean contacts. Check and replace defective parts.
6. **Open circuit: start/stop switch or solenoid**
  - Check. Replace if necessary.
7. **Safety lanyard**
  - Refer to ENGINE MANAGEMENT.
8. **Defective MPEM and/or ECM**
  - Check. Replace if necessary.

Symptom: **STARTER ENGAGES; BUT DOES NOT CRANK THE ENGINE**

---

1. **Weak battery**
  - Recharge or replace battery.
2. **Poor battery cable connections**
  - Clean battery cable connections.
3. **Poor contact of brush**
  - Straighten commutator and brush.
4. **Damaged starter**
  - Replace starter.

Symptom: **STARTER TURNS, BUT STARTER DRIVE DOES NOT MESH WITH RING GEAR**

---

1. **Worn starter drive gear**
  - Replace drive.
2. **Defective drive**
  - Replace drive.

---

**Section 02 TROUBLESHOOTING**  
Subsection 01 (TROUBLESHOOTING CHART)

---

Symptom: **STARTER TURNS, BUT STARTER DRIVE DOES NOT MESH WITH RING GEAR**  
(cont'd)

---

- 3. Poor movement of drive on splines**
  - *Clean and correct.*
- 4. Worn drive bushing**
  - *Replace clutch.*
- 5. Worn ring gear**
  - *Replace ring gear.*

Symptom: **STARTER KEEPS RUNNING**

---

- 1. Shorted solenoid winding**
  - *Replace solenoid.*
- 2. Melted solenoid contacts**
  - *Replace solenoid.*
- 3. Sticking or defective starter drive**
  - *Lubricate or replace.*

## ELECTRICAL SYSTEM

Symptom: **DEPTH GAUGE OPERATIONAL PROBLEM**

---

- 1. Nothing is displayed in the information center**
  - *The depth gauge is not activated in the MPEM. Activate the depth gauge in Options under Setting tab in B.U.D.S.*
- 2. 0.0 (ft or m) is displayed all the time**
  - *Connector of the depth gauge is not connected. Connect it properly.*
  - *There is not 12 V or ground is open at the depth gauge connector. Check fuses and wiring harness.*
  - *Check fuses and wiring harness. Check WHITE/BLACK and WHITE/RED wires.*
- 3. - - - (ft or m) is displayed and Sensor is blinking after self test for 5 seconds**
  - *The watercraft is not in water. Launch watercraft in water and recheck.*
  - *There is air between the depth gauge and the bilge. Check silicone pad under depth gauge.*
  - *Depth gauge is defective. Try a new depth gauge.*

Symptom: **INAPPROPRIATE SPEEDOMETER READING**

---

- 1. Faulty speed sensor or related circuits.**
  - *Refer to GAUGE, SENSORS AND FUSES.*
- 2. MPEM was replaced and speedometer calibration data were not transferred to new MPEM.**
  - *Install latest B.U.D.S version available in BOSSWeb then connect to vehicle with VCK and it will automatically update MPEM. Refer to ENGINE MANAGEMENT.*

## PROPULSION

Symptom: **ABNORMAL NOISE FROM PROPULSION SYSTEM**

---

1. **Weeds/debris caught in intake grate or impeller**  
- *Check and clean.*
2. **Damaged or bent drive shaft**  
- *Check and/or replace. Refer to PROPULSION SYSTEM.*
3. **Idle speed too low**  
- *Check fault codes.*
4. **Broken engine mounts**  
- *Check and repair.*

## STEERING SYSTEM

Symptom: **O.P.A.S. SYSTEM FAULTS**

---

1. **Watercraft is more responsive than usual while turning**  
- *Side vanes do not go up while watercraft is at speed. Refer to STEERING SYSTEM.*
2. **Watercraft pull on one side**  
- *One side vane does not go up while watercraft is at speed. Refer to STEERING SYSTEM.*
3. **Side vanes do not go up while watercraft is at speed**  
- *Clogged filter, square rings damaged, leakage in hoses or mechanical malfunction. Refer to STEERING SYSTEM.*
4. **Side vanes do not go down while watercraft is at idle**  
- *Broken spring inside side vane cylinder. Refer to STEERING SYSTEM.*



# ENGINE REMOVAL AND INSTALLATION

## SERVICE TOOLS

Description	Part Number	Page
alignment shaft.....	295 000 141 .....	30
engine alignment adapter.....	529 035 719 .....	30
plate.....	529 035 507 .....	30
support plate kit.....	529 035 506 .....	30

## SERVICE PRODUCTS

Description	Part Number	Page
dielectric grease .....	293 550 004 .....	29
Loctite 243 (blue).....	293 800 060 .....	29, 31
pulley flange cleaner.....	413 711 809 .....	29
XP-S Lube .....	293 600 016 .....	29

## GENERAL

During assembly/installation, use torque values and service products from exploded views in the appropriate sections.

Clean threads before applying a threadlocker. Refer to *SELF-LOCKING FASTENER* and *LOCTITE APPLICATION* at the beginning of this manual for complete procedure.

**⚠ WARNING**

Torque wrench tightening specifications must strictly be adhered to. Locking devices (e.g.: locking tabs, elastic stop nuts, self-locking fasteners, cotter pin, etc.) must be installed or replaced with new ones where specified. If the efficiency of a locking device is impaired, it must be renewed.

## PROCEDURES

### ENGINE REMOVAL

Place vehicle at workstation that will have access to an engine-lifting hoist.

Drain cooling system, refer to *COOLING SYSTEM*.

Using B.U.D.S., release fuel pressure from fuel system.

Disconnect battery cables from battery.

**⚠ WARNING**

Always disconnect battery cables exactly in the specified order, BLACK (-) cable first then the RED (+) battery cable last.

Disconnect ground wires from engine.

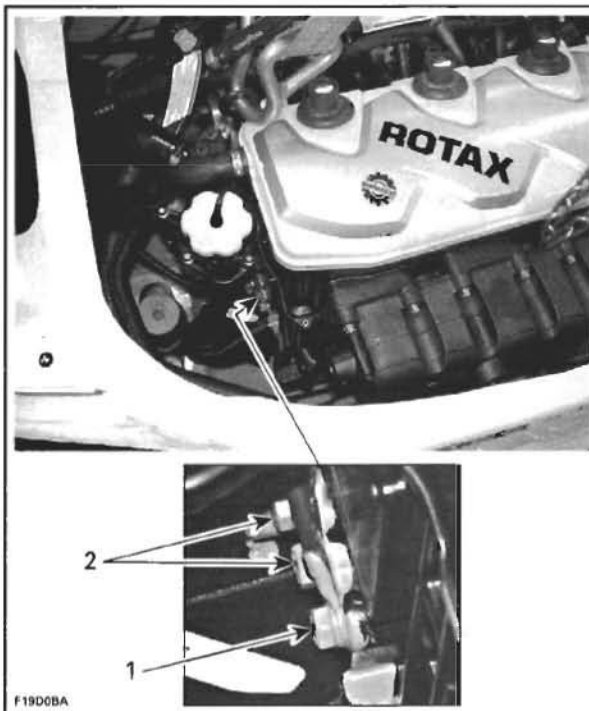

**TYPICAL**  
1. Battery ground  
2. Engine grounds

## Section 03 ENGINE

### Subsection 01 (ENGINE REMOVAL AND INSTALLATION)

#### All Models except RXP

Disconnect magneto wiring harness.

Disconnect the throttle position sensor (TPS), manifold air pressure sensor (MAPS) and manifold air temperature sensor (MATS). Refer to *ENGINE MANAGEMENT* for location of sensors and connectors.

#### RXP Models

Remove engine cover. Refer to *HULL AND BODY*.

Unplug connectors beside ECM then remove connector housings from the support.

Disconnect ECM and remove from engine to prevent any possible damage while pulling engine out.

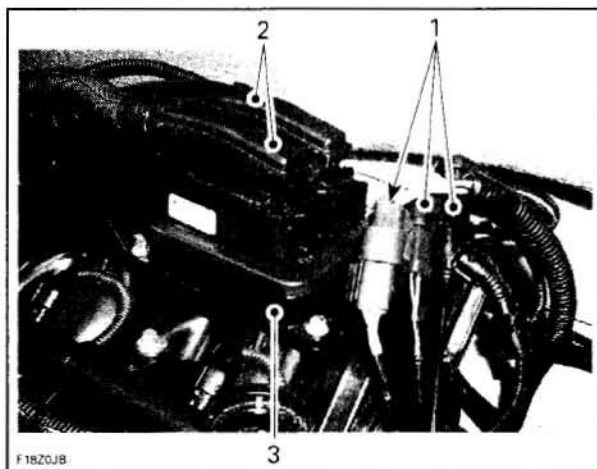

- 1 Remove connectors
- 2 Disconnect ECM
- 3 Remove ECM

Unplug VTS connector.

Cut locking ties retaining vehicle wiring harness to engine.

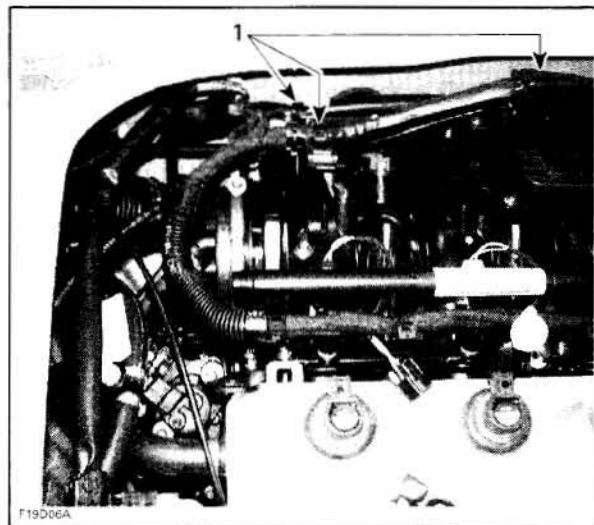

#### VEHICLE WIRING HARNESS

1. Cut locking tie

Move wiring harness forward to make room.

#### All Models

Disconnect TOPS valve hose.

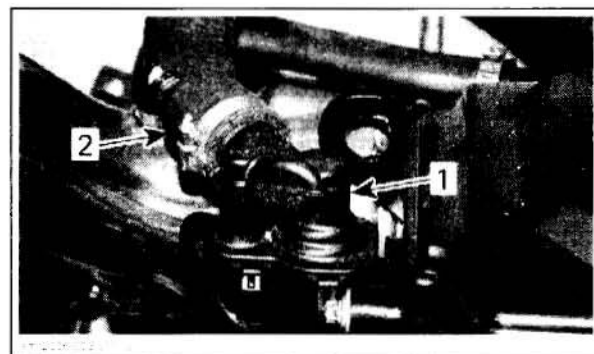

- 1 TOPS valve
- 2 TOPS valve hose

Remove exhaust pipe, refer to *EXHAUST SYSTEM*.

Withdraw jet pump, refer to *JET PUMP*.

Withdraw drive shaft, refer to *DRIVE SYSTEM*.

Disconnect cooling hoses at engine coming from ride plate and coolant expansion tank.

Except RXP models, remove the intake manifold. Refer to *INTAKE MANIFOLD*.

#### GTX Supercharged, GTX Limited and RXT Models

Remove air inlet tube from supercharger and air duct.

#### GTX Limited and RXT

Disconnect water hoses from intercooler.



## Section 03 ENGINE

### Subsection 01 (ENGINE REMOVAL AND INSTALLATION)

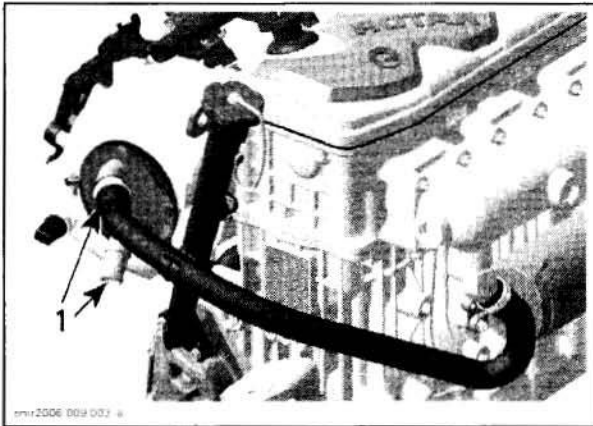

1. Disconnect hoses here

#### RXP Models

Remove inlet hose from throttle body.  
Disconnect throttle cable from throttle body.

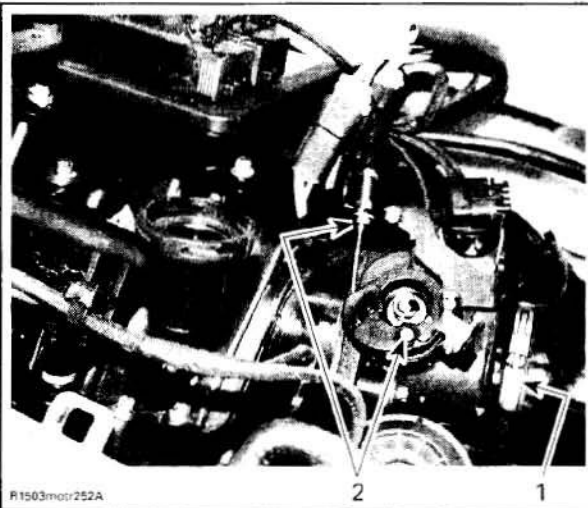

1. Detach hose  
2. Disconnect cable

Disconnect fuel rail supply line.  
Disconnect water inlet hose coming from jet pump connected to the intercooler.

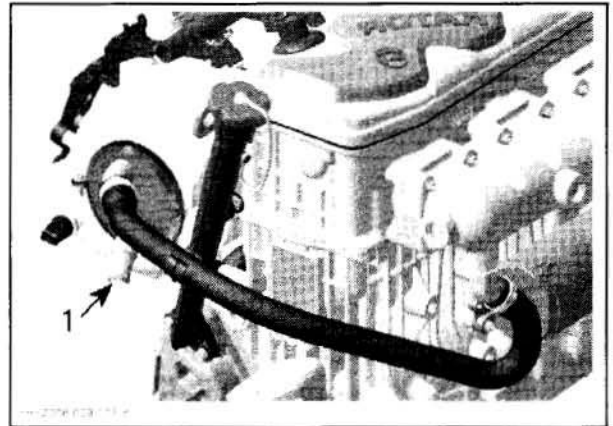

1. Disconnect hose here

#### All Models

Remove engine support mount screws.

**NOTE:** Be careful when removing engine support(s) or rubber mount adapters, shims could have been installed underneath. Shims control engine/jet pump alignment. Always note position of shims for reinstallation, to avoid altering engine alignment.

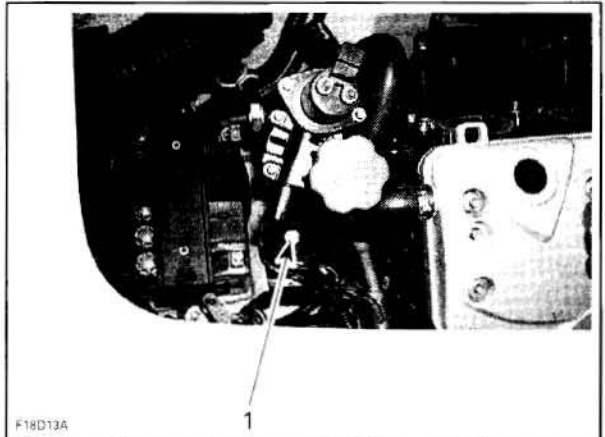

**FRONT SUPPORT**  
1. Remove screw



## Section 03 ENGINE

### Subsection 01 (ENGINE REMOVAL AND INSTALLATION)

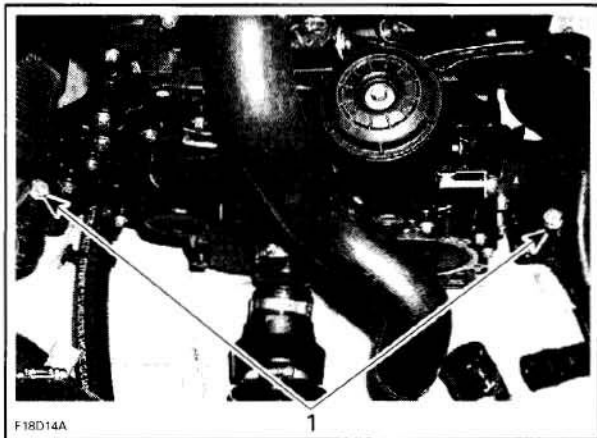

F18D14A  
REAR SUPPORT  
1. Remove screws

Using a chain block, a hoist or other suitable equipment, slightly lift engine to ease the remaining component removal.

**CAUTION:** Take care not to damage cables.

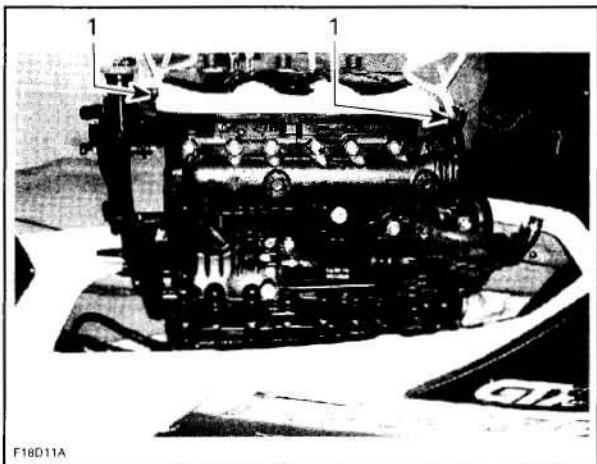

F18D11A  
TYPICAL  
1. Lifting brackets

#### RXP Models

Slightly move engine rearward to take advantage of the larger opening.

The engine have to be hooked-up at an additional location. See illustration.

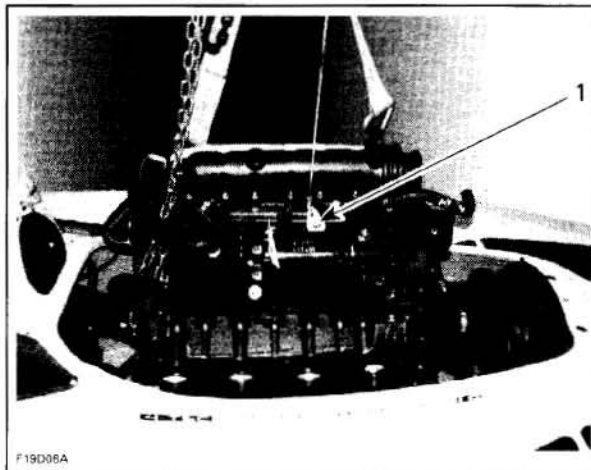

F19D08A  
1. Hook-up a steel rope/chain here

Carefully lift engine by the side with the steel rope/chain and rotate engine so that it can be pulled out of vehicle.

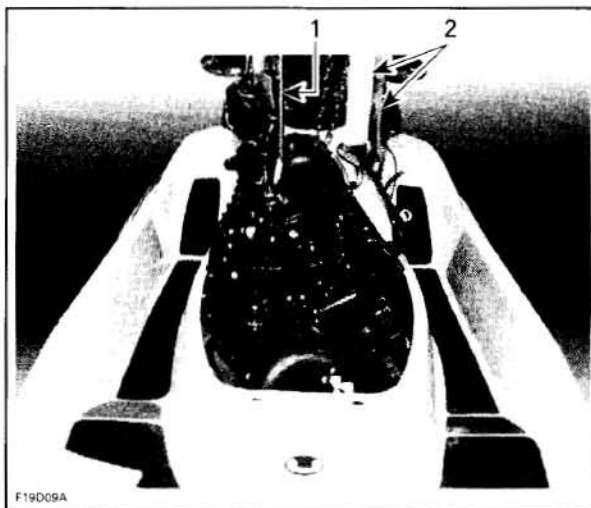

F19D09A  
1. Lift steel rope/chain here to rotate engine  
2. Usual lifting brackets

#### All Models

Carry on engine lifting to remove from the body opening.

**CAUTION:** Be careful not to scratch body or to hit any component.

Disconnect RED (+) cable from starter post.

## Section 03 ENGINE

### Subsection 01 (ENGINE REMOVAL AND INSTALLATION)

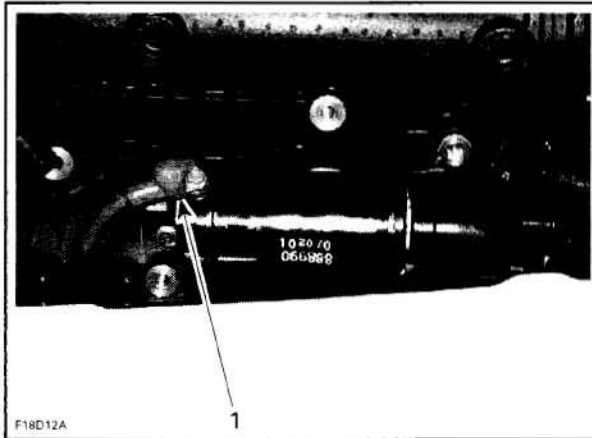

#### TYPICAL

1. Disconnect RED (+) cable

Install the engine on an engine stand.

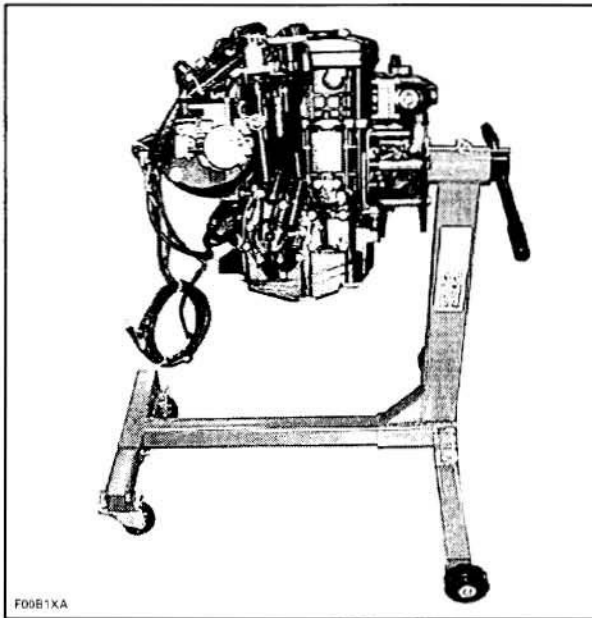

**NOTE:** A special mounting plate is required to fix engine to support. This plate is not sold by BRP.

## CLEANING

Wipe off any spillage in bilge. Clean with the pulley flange cleaner (P/N 413 711 809).

Clean external parts of engine.

## INSTALLATION

**CAUTION:** Whenever engine is removed from watercraft, engine/jet pump alignment must be performed at reinstallation.

Installation of engine in watercraft is essentially the reverse of removal procedures. However pay particular attention to the following:

Check tightness and condition of rubber mounts. If they have been removed, apply Loctite 243 (blue) (P/N 293 800 060) on screw threads. Torque screws to 25 N•m (18 lbf•ft).

**CAUTION:** Strict adherence to this torque is important to avoid damaging threads of aluminum insert in bilge.

Connect starter cable before lowering engine.

Torque nut of positive starter cable to 7 N•m (62 lbf•in). Apply dielectric grease (P/N 293 550 004) on nut.

Ensure contact surface is perfectly clean then reconnect grounds wires/cable to engine.

Place engine into vehicle.

Install engine support screws. Do not apply threadlocker to engine support screws and do not torque yet.

Align engine. Refer to *ENGINE ALIGNMENT* at the end of this section for complete procedure.

Install and properly align exhaust pipe. Refer to *EXHAUST SYSTEM*.

Reinstall all removed parts and connect all connectors.

Check throttle cable condition and lubricate it with XP-S Lube (P/N 293 600 016).

After its installation, properly adjust throttle cable then perform the TPS reset as specified in *ENGINE MANAGEMENT*.

Check hose condition and pressure test fuel system, refer to *FUEL SYSTEM*.

### **⚠ WARNING**

Whenever doing any type of repair on watercraft or if any components of the fuel system are disconnected, a pressure test must be done before starting engine.

Verify all electrical connections (ground wires and battery).

Run engine and ensure there is no leakage.

**CAUTION:** If watercraft is out of water, engine must be cooled using the flush kit.

## ENGINE ALIGNMENT

**NOTE:** To perform this procedure the jet pump and the drive shaft must be removed. Refer to *JET PUMP* and *DRIVE SYSTEM*.



## Section 03 ENGINE

### Subsection 01 (ENGINE REMOVAL AND INSTALLATION)

Check alignment of engine using the following alignment tools:

- the support plate kit (P/N 529 035 506) and the plate (P/N 529 035 507)

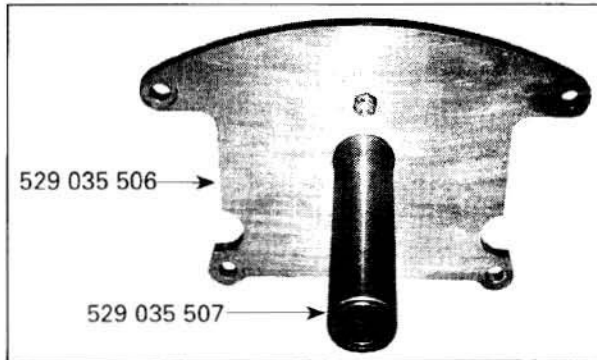

- the alignment shaft (P/N 295 000 141)

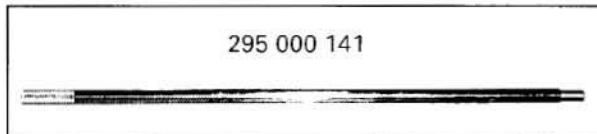

- the engine alignment adapter (P/N 529 035 719).

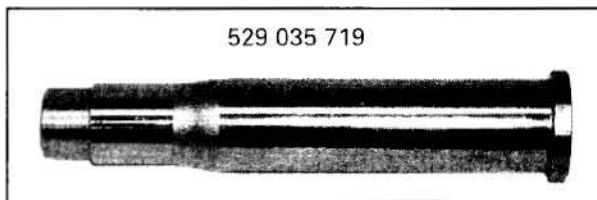

To verify alignment proceed as follows:

- Secure plate and support to hull with four nuts or screws.

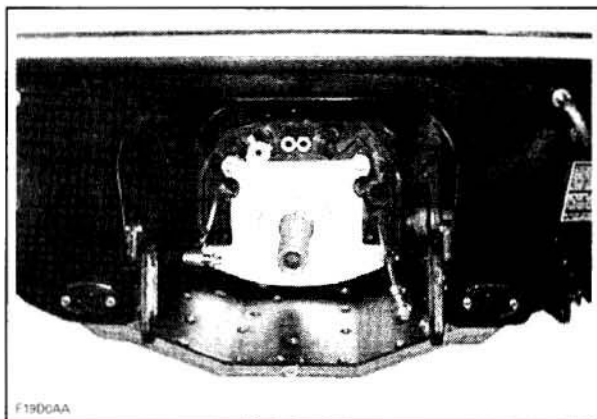

- Install the engine alignment adapter (P/N 529 035 719) in engine PTO housing.

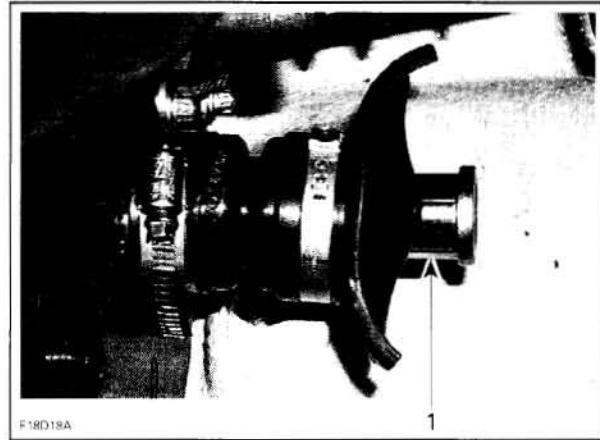

1. Engine alignment adapter.

- Carefully slide shaft through support.
- Insert shaft end into engine alignment adapter.

**NOTE:** Ensure the protective hose and carbon ring is removed to check engine alignment. If the alignment is correct, the shaft will slide easily without any deflection in engine alignment adapter.

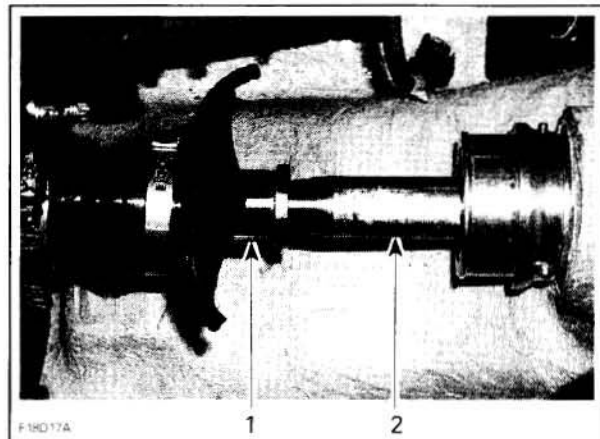

**TYPICAL**

1. Engine alignment adapter  
2. Alignment shaft

If the alignment is incorrect loosen engine support screws to enable to align engine alignment adapter with shaft end.

**NOTE:** Use shim(s) (P/N 270 000 024) or (P/N 270 000 025) between engine supports and rubber mounts to correct alignment.

**CAUTION:** Whenever shims are used to correct alignment, never install more than 5 mm (0.196 in) shim thickness.



**Section 03 ENGINE**  
Subsection 01 (ENGINE REMOVAL AND INSTALLATION)



TYPICAL  
1. Shim

Remove engine support screws and apply Loctite 243 (blue) (P/N 293 800 060) on screw threads. Torque engine support screws to 25 N•m (18 lbf•ft) when procedure is completed.

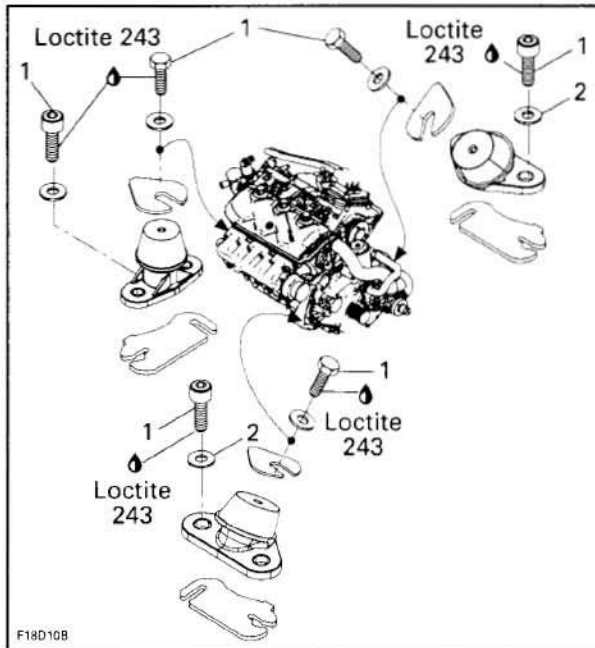

1. Torque to 25 N•m (18 lbf•ft)
2. Position washer to have the "T" mark on top

Remove alignment tools.

# ENGINE LEAK TEST

## SERVICE TOOLS

Description	Part Number	Page
Drive shaft adapter .....	529 035 892 .....	34
Drive shaft adapter .....	529 035 985 .....	34
leak down tester.....	529 035 661 .....	34

## SERVICE PRODUCTS

Description	Part Number	Page
Molykote 111.....	413 707 000 .....	35

The procedure has to be done when engine operating temperature of approx. 70°C (158°F) is reached.

**⚠ WARNING**

Prevent burning yourself due to handling on the hot engine.

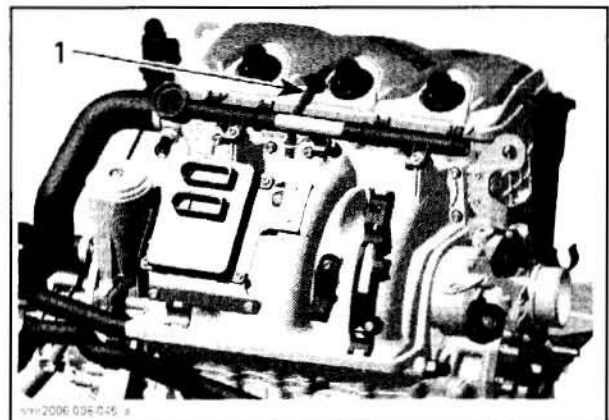

1. Oil dipstick

## PREPARATION

Remove any parts to have access to engine.  
Remove safety lanyard.

**⚠ WARNING**

Safety lanyard must be removed to prevent engine to be cranked while fuel rail is removed to prevent fuel to be sprayed out. Fuel is flammable.

Unplug and remove ignition coils.  
Remove spark plugs.  
**NOTE:** Ignition coil may be used as an extractor.

Remove jet pump (refer to *JET PUMP*).  
Remove coolant tank cap.

**⚠ WARNING**

To avoid potential burns, only remove the coolant tank cap by wearing the appropriate safety equipment.

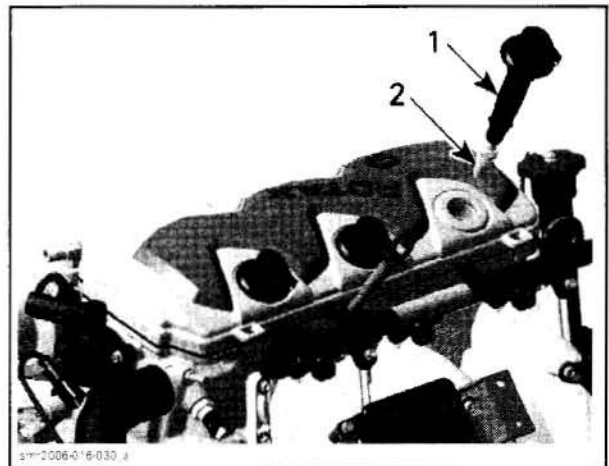

1. Ignition coil  
2. Spark plug

Remove oil dipstick.

Remove valve cover cowl.

## Section 03 ENGINE

### Subsection 02 (ENGINE LEAK TEST)

Unscrew and remove valve cover.

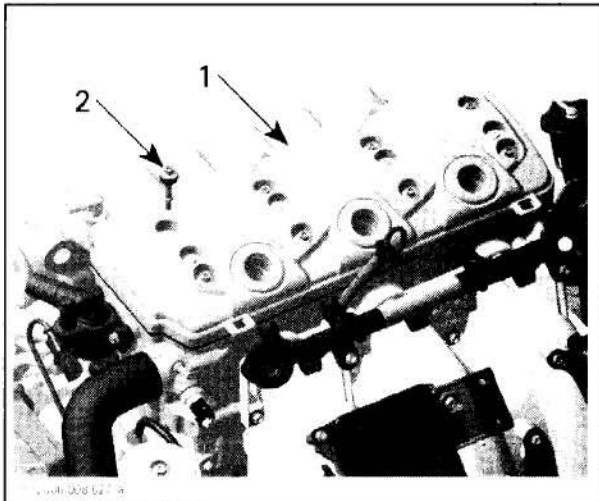

- 1 Valve cover
- 2 Valve cover screw

With an appropriate wrench lever, engine is rotated using the drive shaft adapter. Refer to the following table.

ENGINE	TOOL
1503 4-TEC Supercharged intercooled	Drive shaft adapter (P/N 529 035 985)
All other 1503 engines	Drive shaft adapter (P/N 529 035 892)

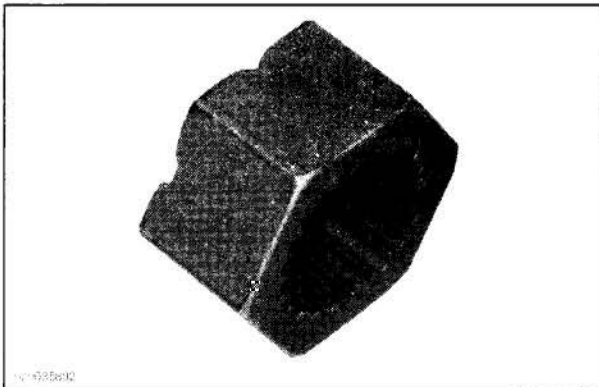

DRIVE SHAFT ADAPTER

## PROCEDURE

### Leak Test

Rotate engine counterclockwise until the cylinder no. 1 is at Top Dead Center (TDC) compression stroke.

**NOTE:** Cylinder numbers are molded on valve cover.

As the engine is turned over, observe the movement of intake rocker arm of the cylinder to be checked. After it completes the cycle and the intake valve closes, observe the piston. When it reaches its uppermost position that is TDC compression stroke.

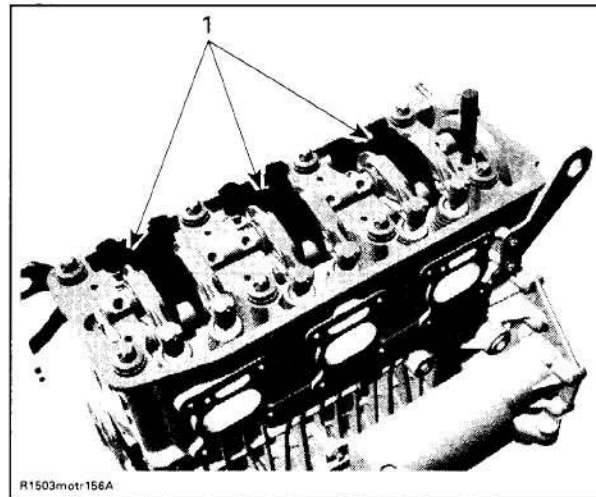

1. Intake rocker arms

Protect the hull area then position the wrench lever so that it rest against hull to prevent further crankshaft rotation.

Install gauge adapter from the leak down tester (P/N 529 035 661) into spark plug hole.

Connect to adequate air supply.

**NOTE:** Each tester will have specific instruction on the gauge operation and required pressure. Refer to manufacturer's instructions.

Set needle of measuring gauge to zero.

Supply combustion chamber with air.



## Section 03 ENGINE

### Subsection 02 (ENGINE LEAK TEST)

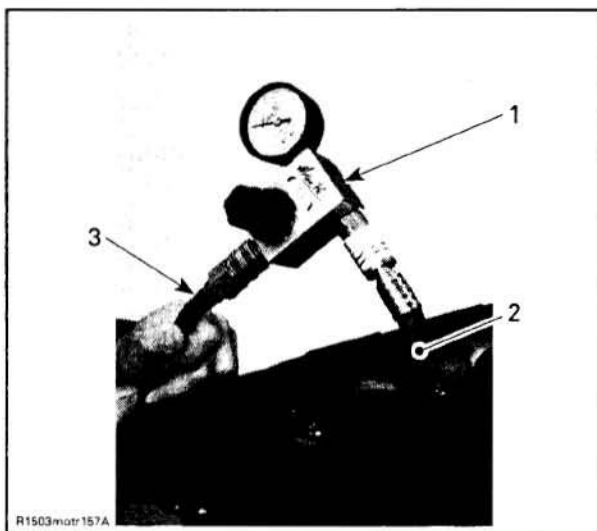

**TYPICAL**  
 1. Leak down tester gauge  
 2. Gauge adapter  
 3. Air supply hose

Note the amount of leaking or percentage (depending on tester).

LEAKAGE PERCENTAGE	ENGINE CONDITION
0% to 15%	Excellent condition.
16% to 25%	Good condition
26% to 40%	Fair condition; engine will run and performance might be down in some cases.
41% and higher	Poor condition, diagnose and repair engine.

Proceed the same way with remaining cylinders.

### Diagnosis

Pressurize area to be tested, spray soap/water solution at the indicated location and look and/or listen for air bubbles.

- air escaping on intake port means leaking intake valve(s)
- air escaping on exhaust port means leaking exhaust valve(s)
- air bubbles out of coolant tank means leaking cylinder head gasket
- air escaping into crankcase means excessively worn and/or broken piston rings.

### Possible Engine Leakage Area

Spray soap/water solution at the indicated location and look and/or listen for air bubbles.

Pay attention to the following checkpoints:

- clamp(s) tightened
- coolant hoses
- air/oil escaping from crankcase means damaged gasket(s) and/or loosened screws (refer to *ENGINE BLOCK*)
- air/water escaping from cylinder/head means damaged gasket(s) and/or loosened screws (refer to *CYLINDER HEAD*)
- oily contamination on leak indicator hole means a damaged oil seal on coolant pump shaft
- coolant escaping from leak indicator hole means a damaged rotary seal on coolant pump shaft (refer to *COOLING SYSTEM*)

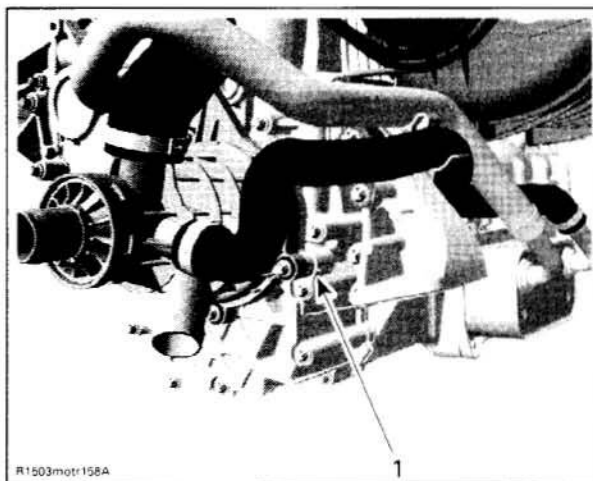

1. Leak indicator hole

- coolant escaping from coolant pump housing means damaged gasket(s) and/or loosened screws (refer to *COOLING SYSTEM*).

### Assembly

For assembly, reverse the preparation procedure. Use torque values and service products from the exploded views (refer to proper *ENGINE* sections).

Prior to inserting each ignition coil, apply some Molykote 111 (P/N 413 707 000) around the seal area that touches the spark plug hole. After installation, ensure the seal seats properly with the valve cover.

# AIR INTAKE SYSTEM

## SERVICE TOOLS

Description	Part Number	Page
hook tool.....	529 035 989 .....	39

### 1503 4-TEC Naturally Aspirated Engines

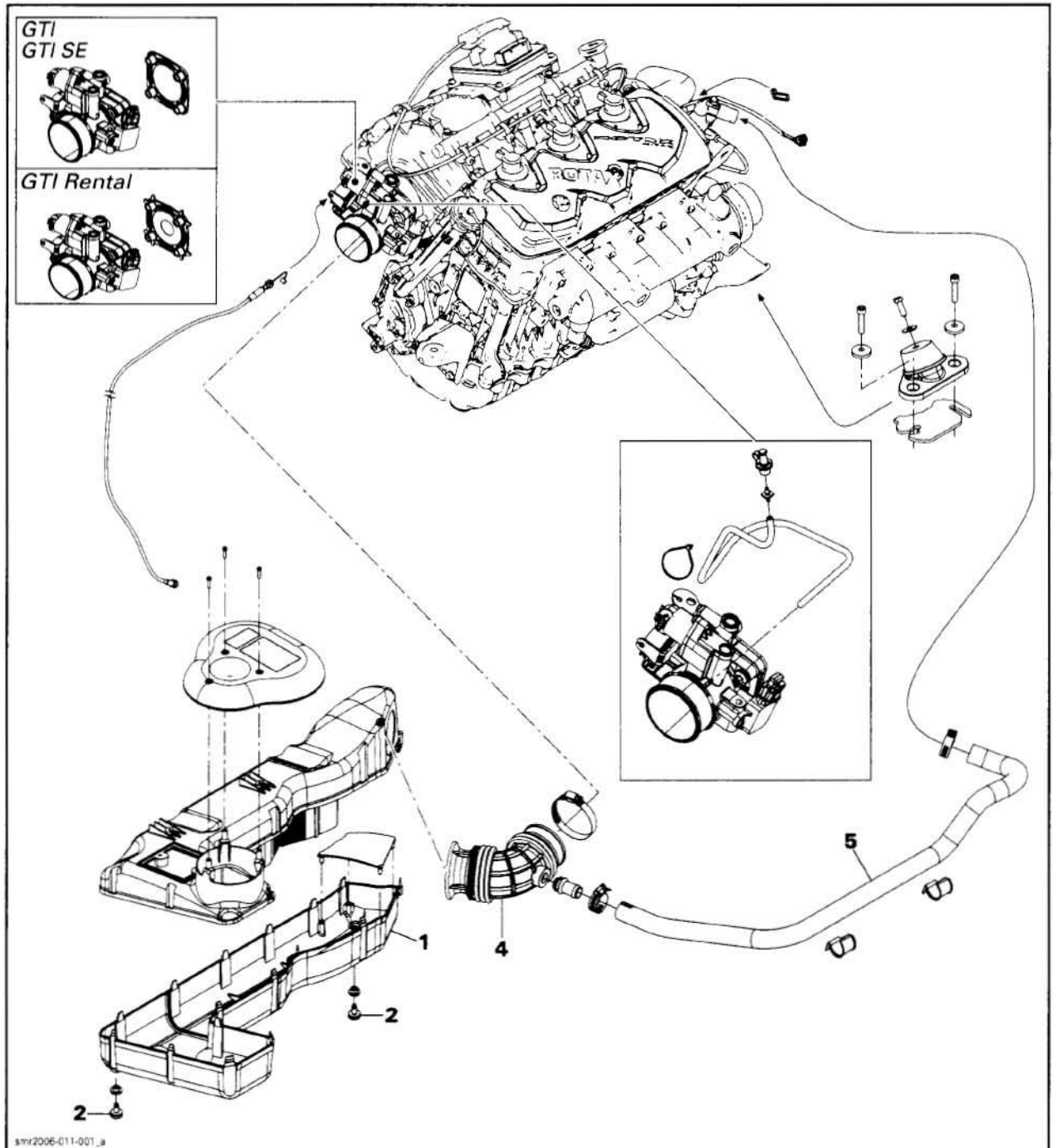

smr2006-011-001\_a

**Section 03 ENGINE**  
Subsection 03 (AIR INTAKE SYSTEM)

**All 1503 4-TEC Supercharged Engines**

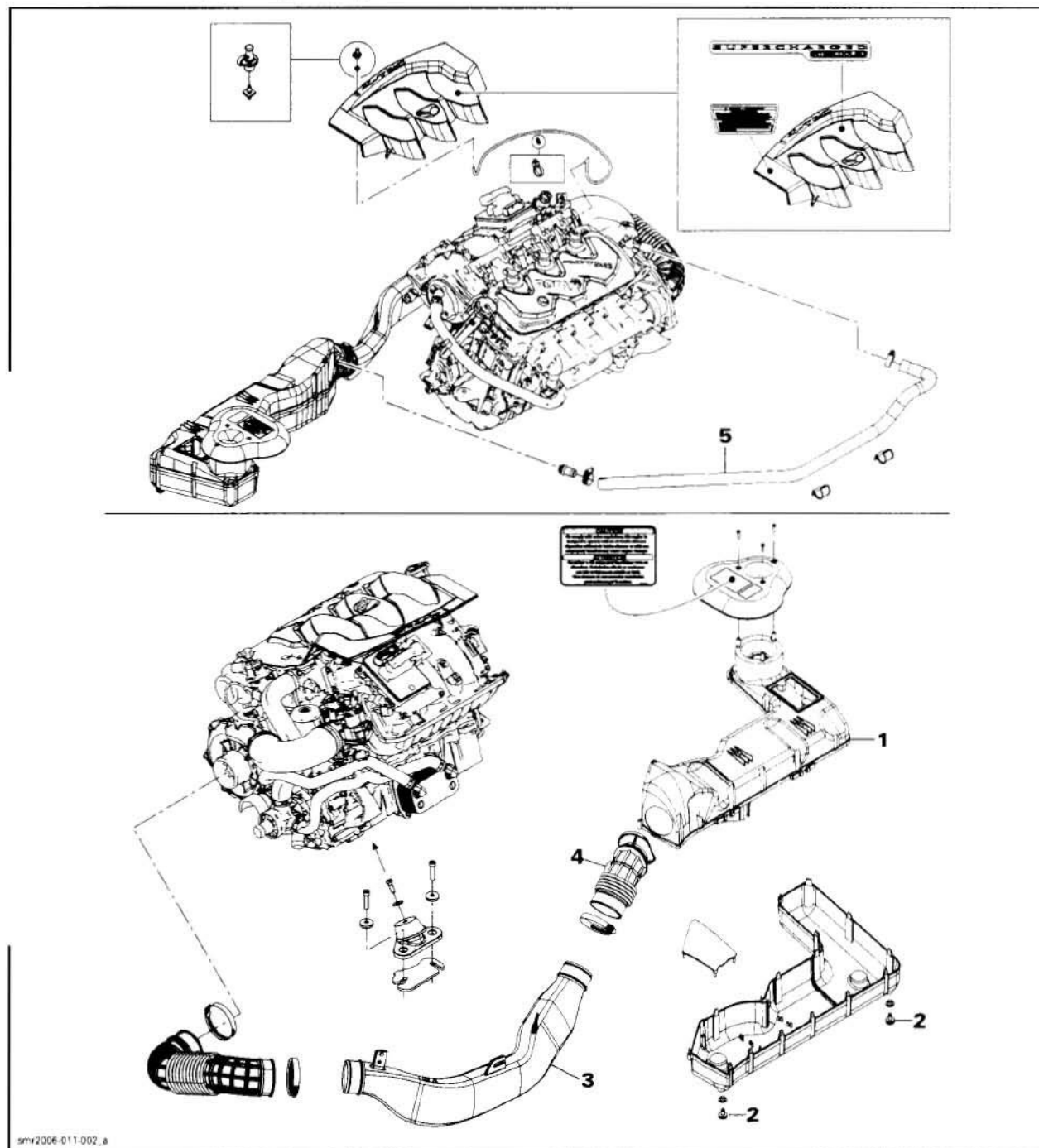

smr2006-011-002\_a



## INSPECTION

Check for water in air silencer **no. 1**. If so, replace check valves **no. 2**. Check collar tightness. Ensure there is no water trapped in tube **no. 3** on supercharged engines.

Inspect silencer, tube and hose condition. Replace any damaged part.

## REMOVAL

From storage compartment, remove/disconnect:

- hose **no. 4**.

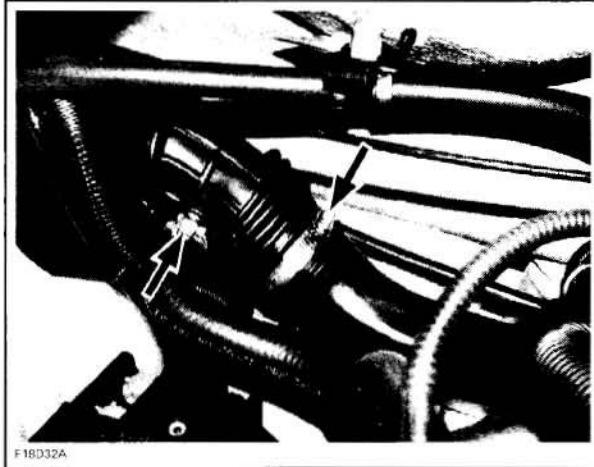

- front access door (if so equipped)

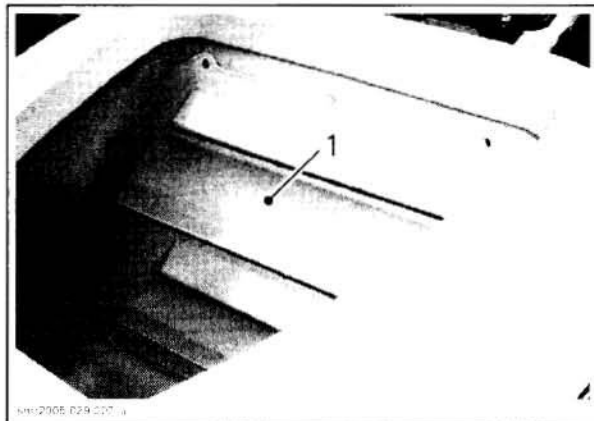

1. Access door

- front vent tube (RXP only)

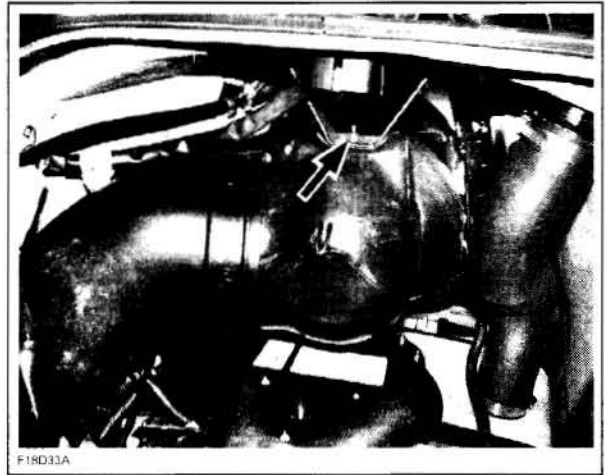

- rectifier/voltage regulator
- wiring harness from air silencer



- fuel tank straps (refer to *FUEL SYSTEM*) using hook tool (P/N 529 035 989).

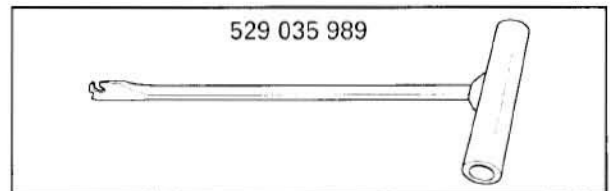

Pull air silencer out.

### **All 1503 4-TEC Supercharged Engines**

From engine compartment, remove/disconnect:

- vent tube

## Section 03 ENGINE

### Subsection 03 (AIR INTAKE SYSTEM)



1. Lift lock tab

– coolant expansion tank

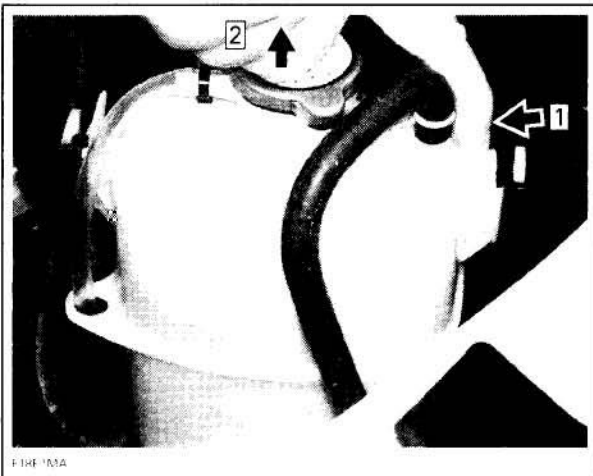

Step 1: Push tab each side to release  
Step 2: Pull tank out

– vent tube support

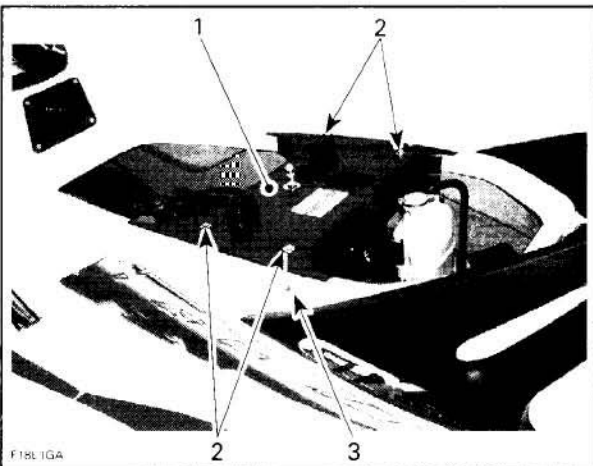

1. Vent tube support  
2. Remove retaining screws  
3. Pay attention to nuts underneath

– tube from air intake hose.

Pull tube out.

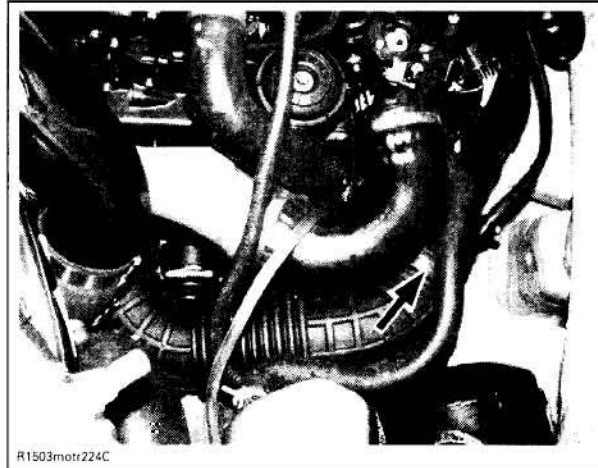

## INSTALLATION

Reverse removal operation order and pay attention to the following.

Ensure that tubes are well secured with hoses and there is a tight fit.

# INTAKE MANIFOLD AND INTERCOOLER

## SERVICE TOOLS

<b>Description</b>	<b>Part Number</b>	<b>Page</b>
leak test pump.....	529 021 800 .....	51

## SERVICE PRODUCTS

<b>Description</b>	<b>Part Number</b>	<b>Page</b>
Loctite 243.....	293 800 060 .....	49



## Section 03 ENGINE

### Subsection 04 (INTAKE MANIFOLD AND INTERCOOLER)

#### Naturally Aspirated Engine

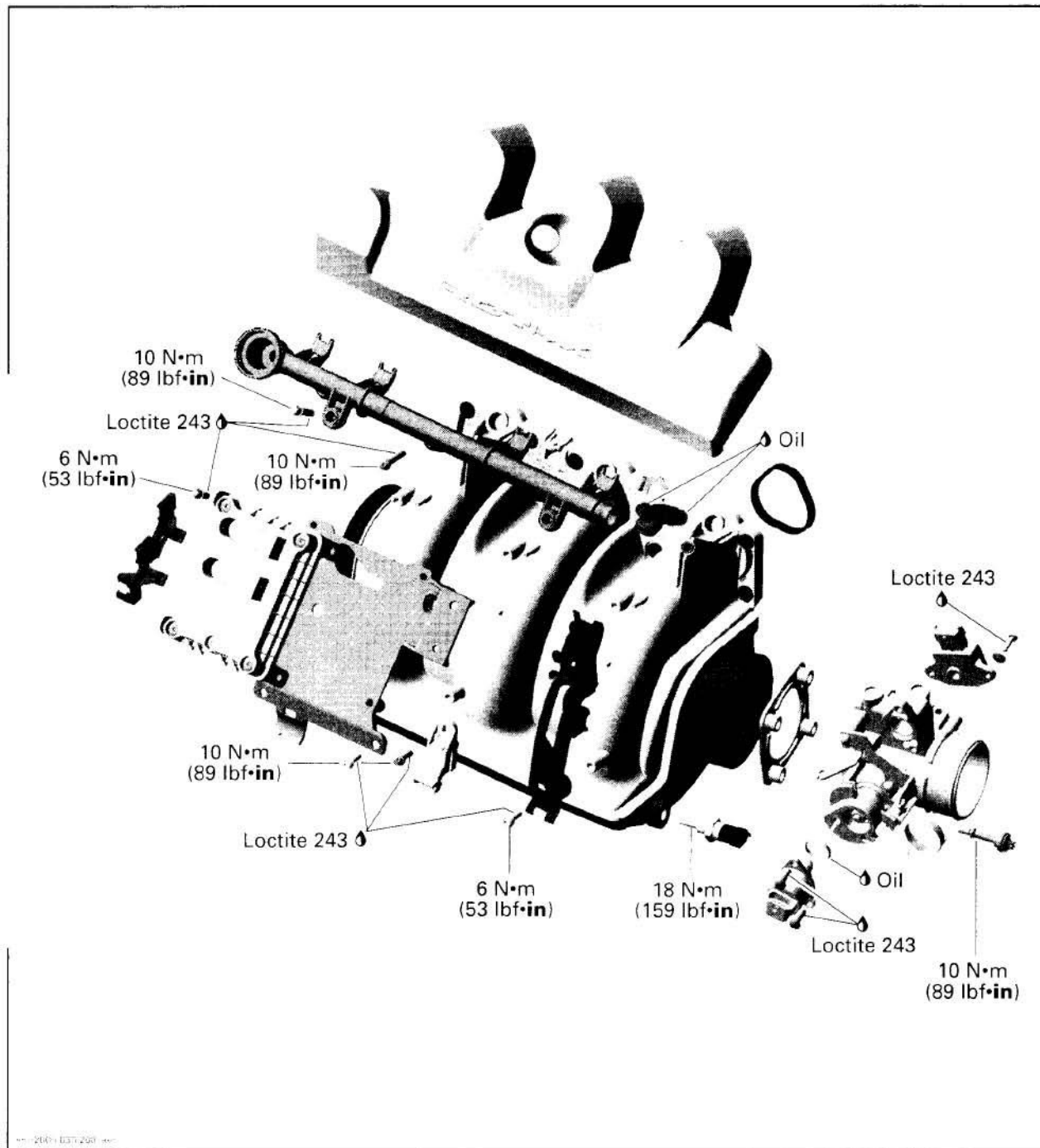



## Section 03 ENGINE

### Subsection 04 (INTAKE MANIFOLD AND INTERCOOLER)

#### Supercharged Intercooled Engine

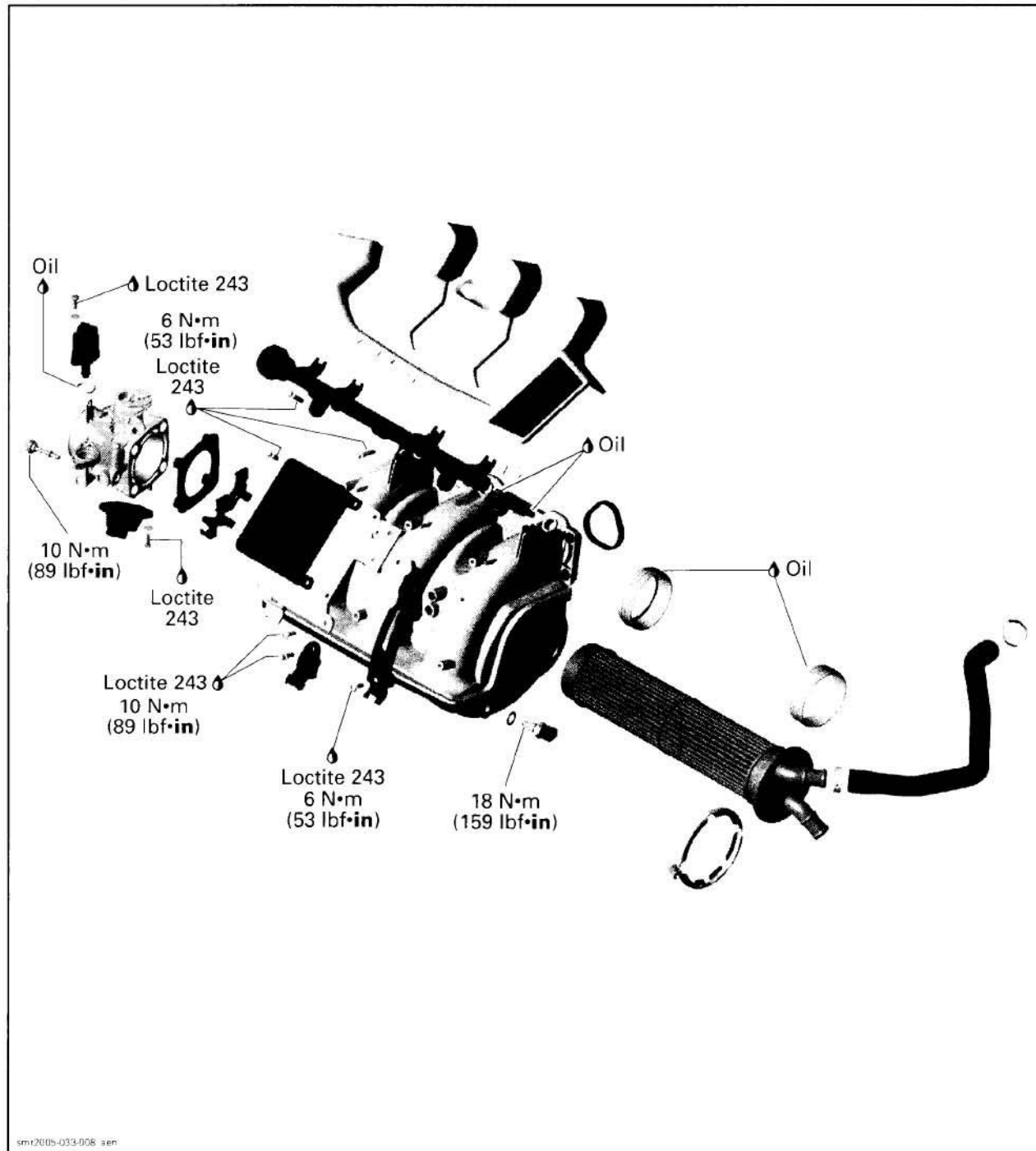



**PROCEDURES**

**INTAKE MANIFOLD**

**Intake Manifold Removal**

As necessary, remove: Seat, vent tube, coolant expansion tank and vent tube support.

Remove oil dipstick.

Pull fuel rail cover out.

Release the fuel pressure.

Disconnect battery cables from battery.

**⚠ WARNING**

Always disconnect battery cables exactly in the specified order, **BLACK** negative cable first then the **RED** positive battery cable last.

Disconnect fuel hose connector at fuel rail.

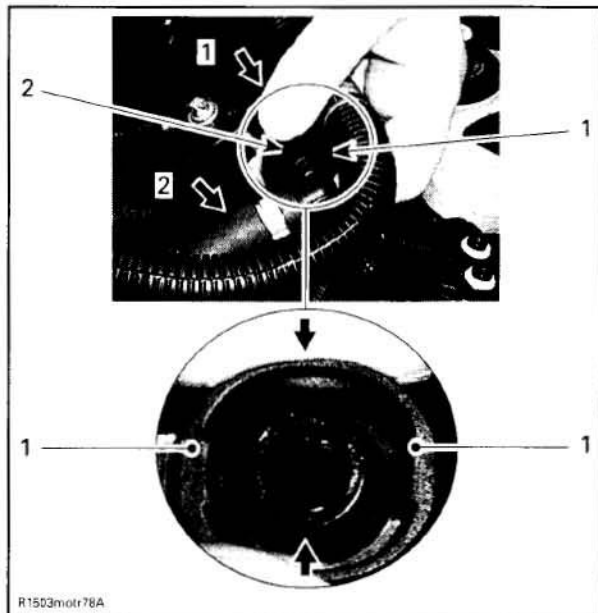

- Step 1: Squeeze  
 Step 2: Pull out  
 1. Supporting tabs  
 2. Squeeze in middle of supporting tabs, hold and pull out

Cut locking ties where shown.

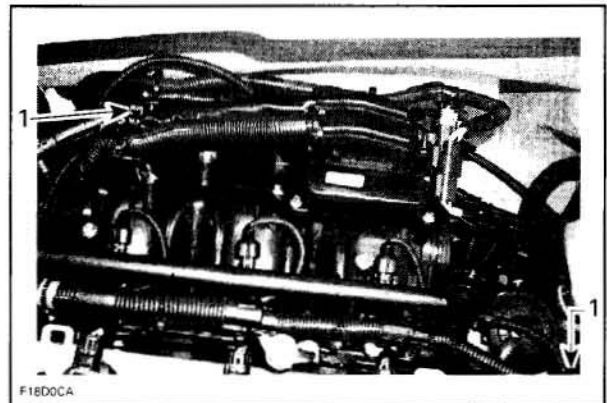

**NATURALLY ASPIRATED ENGINE**  
 1. Cut locking ties to release harness



**SUPERCHARGED ENGINE**  
 1. Cut locking ties to release harness

Unplug electrical connectors.

## Section 03 ENGINE

### Subsection 04 (INTAKE MANIFOLD AND INTERCOOLER)

#### Naturally Aspirated Engine

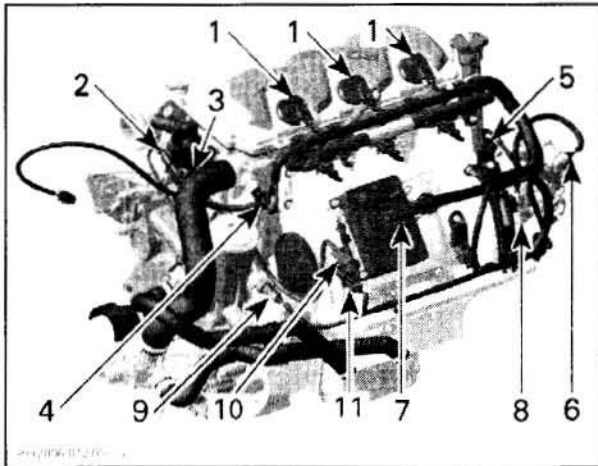

- 1. Ignition coils
- 2. CPS
- 3. CAPS (hidden behind water hose)
- 4. CTS
- 5. TPS
- 6. Idle bypass valve
- 7. "B" Kostal connector
- 8. Engine connector
- 9. OPS
- 10. Magneto
- 11. KS

**NOTE:** The CAPS connector is hidden behind the water hose. Slightly pry locking tab of connector to unlock.

#### Supercharged Engines

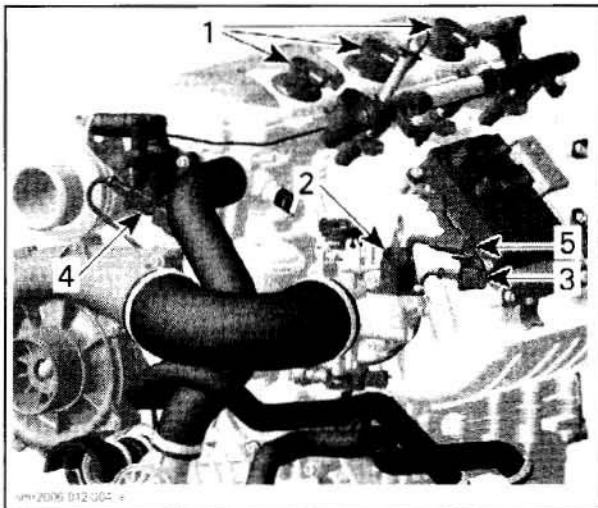

- 1. Ignition coils
- 2. Idle bypass valve
- 3. KS
- 4. CPS
- 5. Magneto

#### All Engines

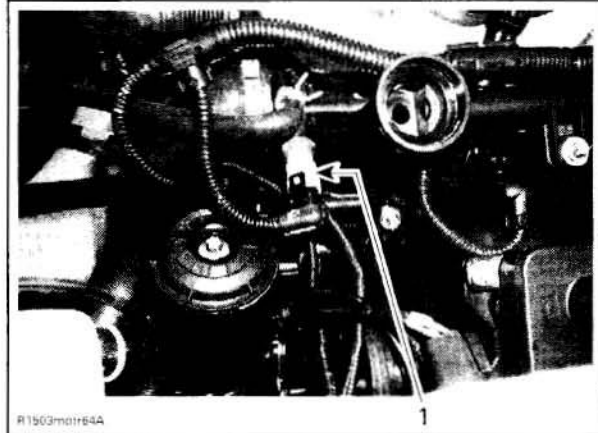

**TYPICAL**  
1. CTS connector

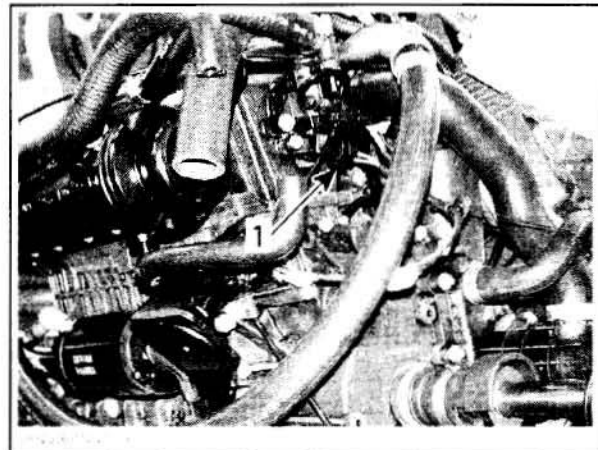

1. CAPS connector

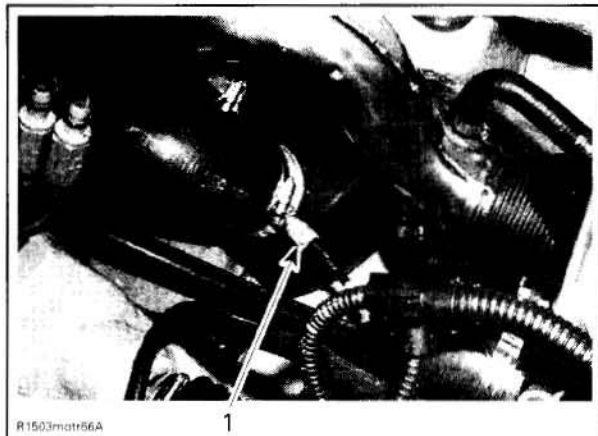

**TYPICAL**  
1. EGTS connector



## Section 03 ENGINE

### Subsection 04 (INTAKE MANIFOLD AND INTERCOOLER)

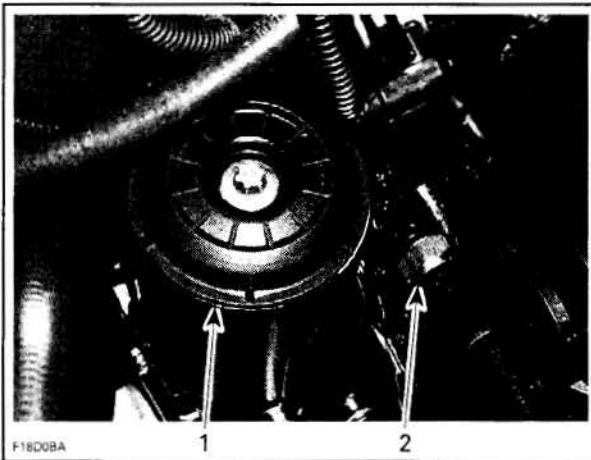

1. Oil filter housing
2. OPS

Unplug the "B" connector from the ECM.

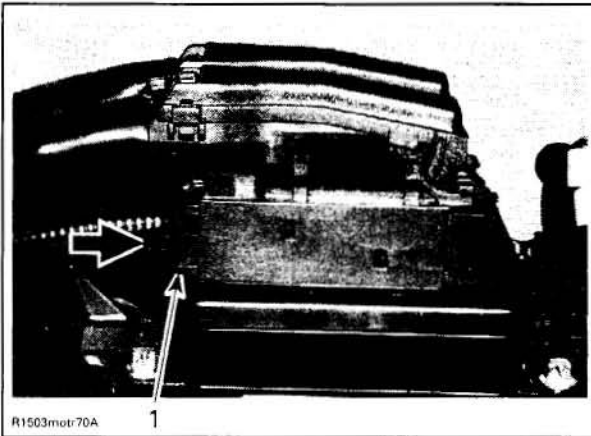

1. Push this end to unlock

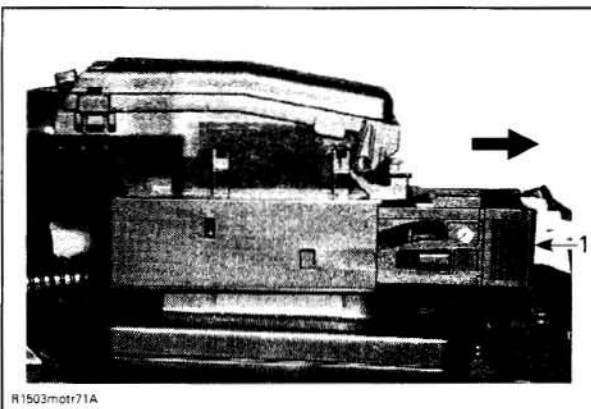

1. Pull here to release

Pull the connectors for the knock sensor (KS), crankshaft position sensor (CPS) and magneto out of the ECM support. For more details, refer to *ELECTRICAL CONNECTORS*.

Disconnect knock sensor (KS) and crankshaft position sensor (CPS) connectors.

Cut locking ties as necessary and pull wiring harness away from intake manifold.

#### **Naturally Aspirated Engine**

Loosen air intake silencer collar.

Unlock throttle cable housing from throttle body. Cable is to be detached later on.

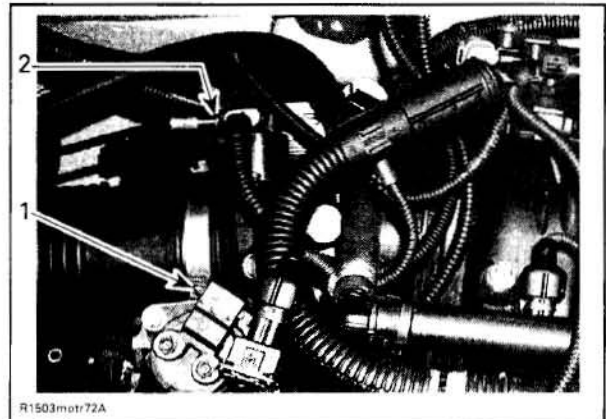

1. Air intake silencer collar
2. Unlock throttle cable housing

#### **Supercharged Engines**

Remove inlet hose from throttle body.

Disconnect throttle cable from throttle body.

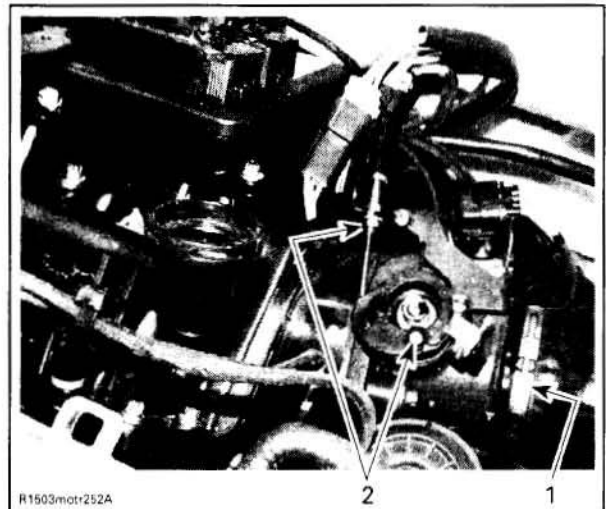

1. Detach hose
2. Disconnect cable

#### **Supercharged Intercooled Engine**

Remove the hoses connected to the intercooler.



## Section 03 ENGINE

### Subsection 04 (INTAKE MANIFOLD AND INTERCOOLER)

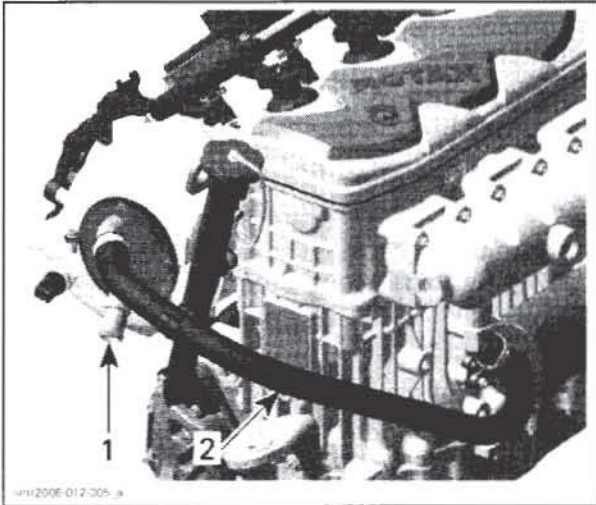

1. Hose from intercooler to exhaust manifold (outlet nipple)
2. Hose from jet pump

#### All Engines

Remove manifold retaining screws and push the oil dipstick tube out of the manifold slot.

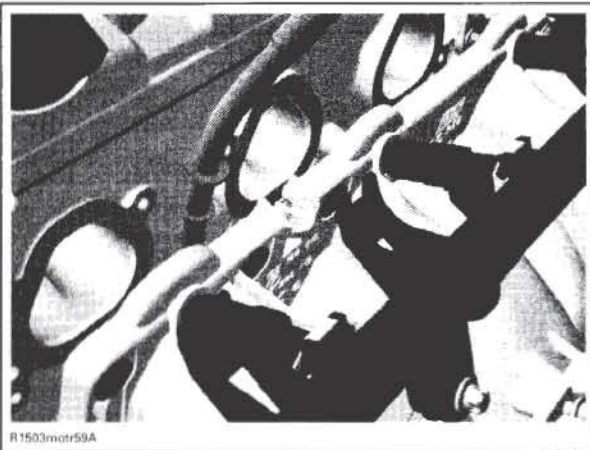

Lift intake manifold up to pull it out of the mounting brackets just enough to reach throttle cable end.

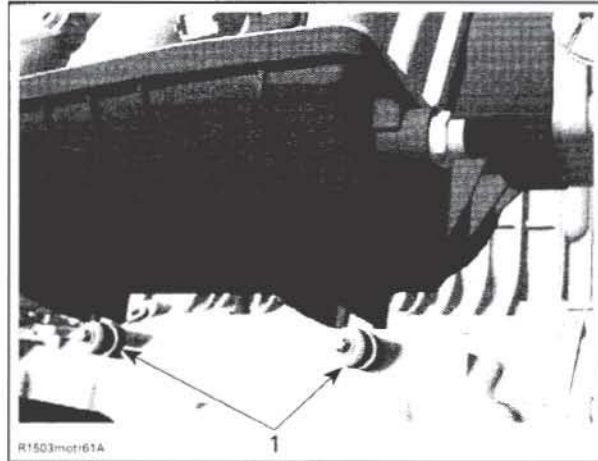

1. Mounting brackets

#### Naturally Aspirated Engine

Detach throttle cable end from throttle body.

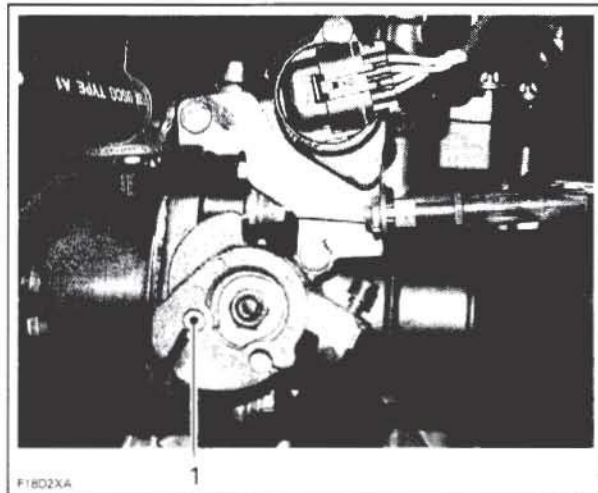

1. Detach cable end from throttle body

#### All Engines

Pull intake manifold out.

## Section 03 ENGINE

### Subsection 04 (INTAKE MANIFOLD AND INTERCOOLER)



TYPICAL

**NOTE:** The flame arrester and the intercooler (if so equipped) in the intake manifold are maintenance free.

#### Intake Manifold Installation

Ensure that all gaskets are properly installed and in a good condition.

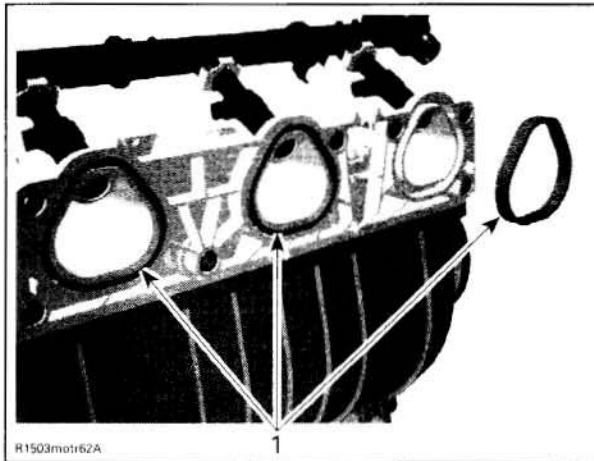

INTAKE MANIFOLD  
1. Gaskets

First, position intake manifold on front mounting bracket then push manifold toward engine to then proceed with rear mounting bracket.

When installing the intake manifold, lift up the oil dipstick tube a little bit to fit in the slot of the manifold.

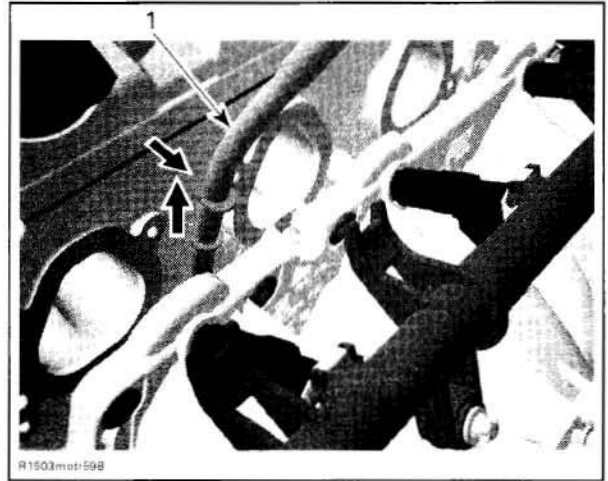

1. Oil dipstick tube

Apply Loctite 243 (P/N 293 800 060) on the intake manifold screws. Torque them to 10 N•m (89 lbf•in) following the tightening sequence shown.

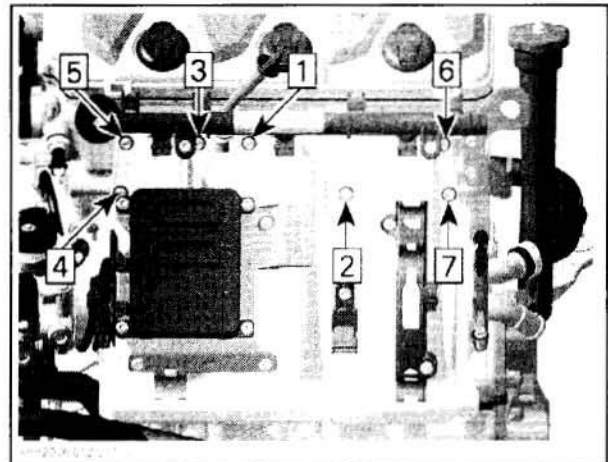

Ensure to properly route and resecure wiring harness with locking ties.

#### **WARNING**

Always check O-ring for damage such as deformation at reinstallation. Replace the O-ring if it is damaged.

When installing throttle cable, ensure cable is in the proper position of bracket and that cable barrel is in the proper position of throttle cam.



## Section 03 ENGINE

### Subsection 04 (INTAKE MANIFOLD AND INTERCOOLER)

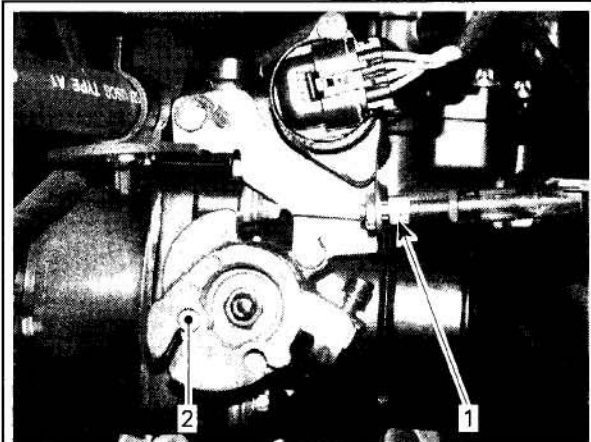

F18D2XB

#### 4-TEC NATURALLY ASPIRATED ENGINES

1. Cable position in bracket
2. Cable barrel position in cam

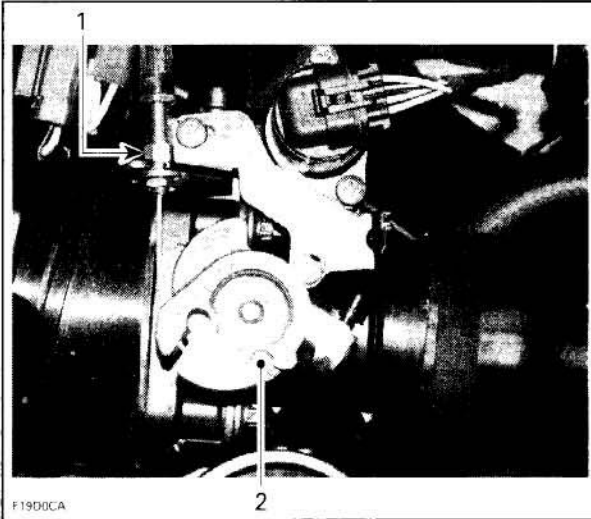

F19D0CA

#### 4-TEC SUPERCHARGED ENGINES

1. Cable position in bracket
2. Cable barrel position in cam

Readjust throttle cable and reset the TPS using the B.U.D.S. software. Refer to *ENGINE MANAGEMENT*.

#### Supercharged Intecooled Engine

Make sure the outlet hose of the intercooler is installed in the holding device otherwise the hose will scuff on the engine block.

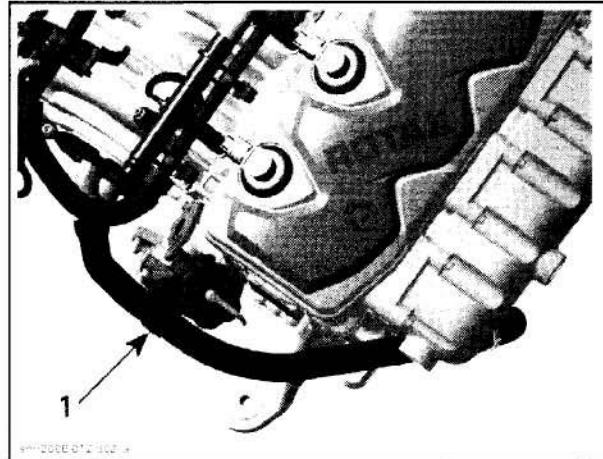

1. Intercooler outlet hose holding device

## INTERCOOLER

### Supercharged Intercooled Engine

#### Intercooler Leak Test

Perform intercooler leak test when engine loses performance, when there is white exhaust smoke or when temperature in exhaust system is to high.

#### **WARNING**

Let engine cool down prior to perform leak test. Direct contact with hot engine may result in skin burn.

**NOTE:** The inspection can be done while intercooler remains installed in intake manifold.

Remove:

- outlet hose from exhaust manifold
- inlet hose from intercooler.



## Section 03 ENGINE

### Subsection 04 (INTAKE MANIFOLD AND INTERCOOLER)

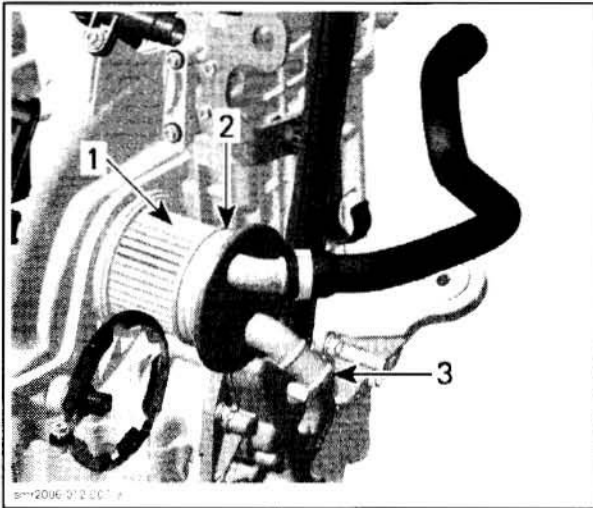

INTERCOOLER PULLED OUT FOR CLARITY PURPOSE ONLY

1. Intercooler
2. Outlet hose
3. Inlet nipple

Plug intercooler inlet nipple.

Install an adapter on the outlet hose to connect the leak test pump (P/N 529 021 800).

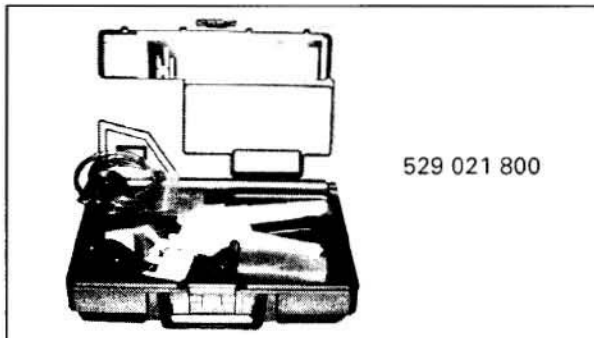

529 021 800

Pressurize the intercooler as follows:

PRESSURE TEST
69 kPa (10 PSI) for 10 minutes min.

If there is a pressure drop, first spray hoses and adapters with a soapy solution to ensure they are not leaking.

Otherwise, remove intercooler from manifold to spray soapy water on it. If air bubbles are present, replace the intercooler. Refer to procedures farther in this section.

Properly reinstall removed parts.

Make sure the intercooler outlet hose is installed in the holding device otherwise the hose will scuff on the engine block.

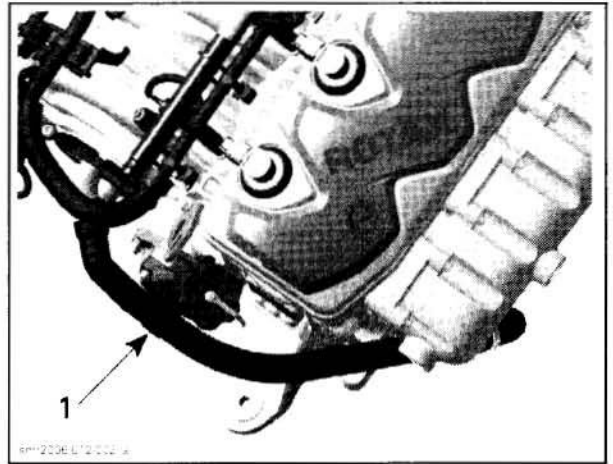

1. Intercooler outlet hose holding device

### Intercooler Removal

Remove intake manifold.

Remove collar from intercooler.

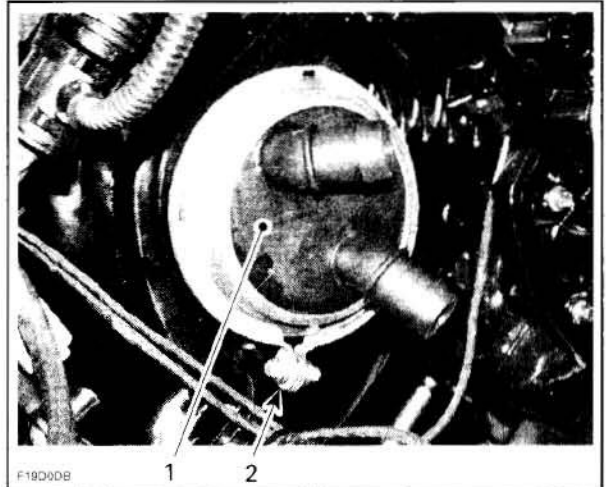

- TYPICAL
1. Intercooler
  2. Collar

Carefully pull intercooler out of intake manifold.

## Section 03 ENGINE

### Subsection 04 (INTAKE MANIFOLD AND INTERCOOLER)

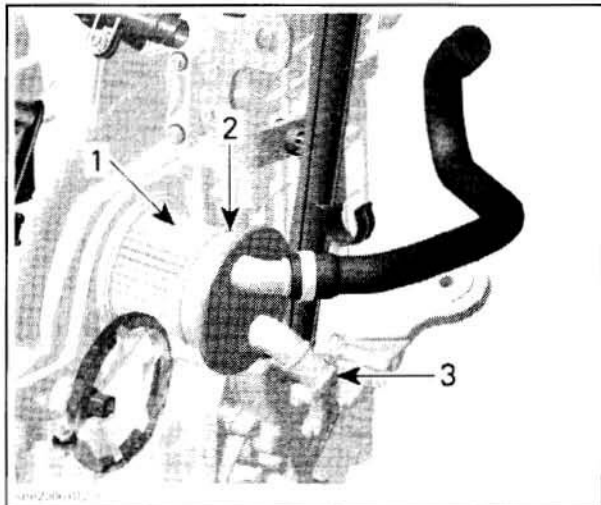

1. Intercooler
2. Profile Ring
3. Collar

#### Intercooler Installation

Installation is essentially the reverse of removal procedures. However pay particular attention to the following.

Ensure profile rings are properly installed on intercooler and apply 4-stroke oil on them to ease installation.

While properly aligning the inner end of intercooler in intake manifold, gently push intercooler until it bottoms.

Rotate intercooler to position nipples as shown.

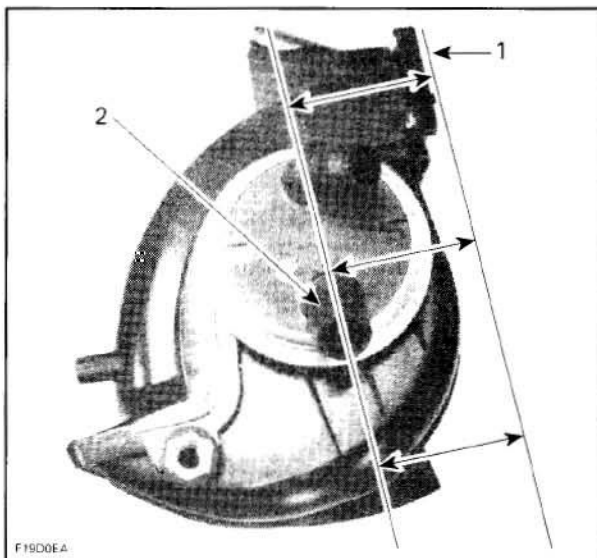

1. Intake manifold flange
2. Nipple parallel with manifold flange

**NOTE:** If intercooler is hard to push in, a clamp can be used to press intercooler in.

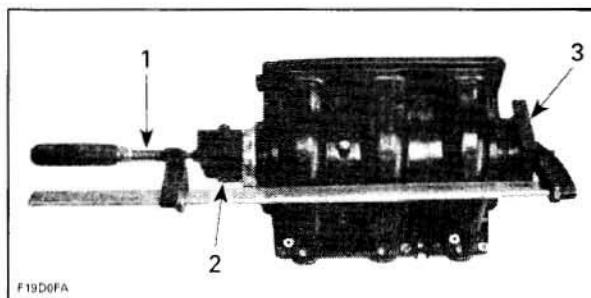

1. Clamp
2. Plastic block between nipples
3. Plastic block

Reinstall collar.

Reinstall intake manifold.

# SUPERCHARGER

## SERVICE TOOLS

<b>Description</b>	<b>Part Number</b>	<b>Page</b>
4-pin socket .....	529 035 948 .....	59, 61
camshaft locking tool.....	529 035 839 .....	55
gear holder .....	529 036 025 .....	64
retaining key .....	529 036 027 .....	57–58, 63
support plate.....	529 035 947 .....	60–61
support/pusher .....	529 035 950 .....	60–61
Torx adapter .....	529 035 938 .....	56, 65

## SERVICE PRODUCTS

<b>Description</b>	<b>Part Number</b>	<b>Page</b>
Kluber Isoflex grease .....	293 550 021 .....	63
Loctite 243.....	293 800 060 .....	61–63, 65
Loctite 5910.....	293 800 081 .....	63
Super Lube grease .....	293 550 030 .....	64



**Section 03 ENGINE**  
Subsection 05 (SUPERCHARGER)

**Supercharged Engines**

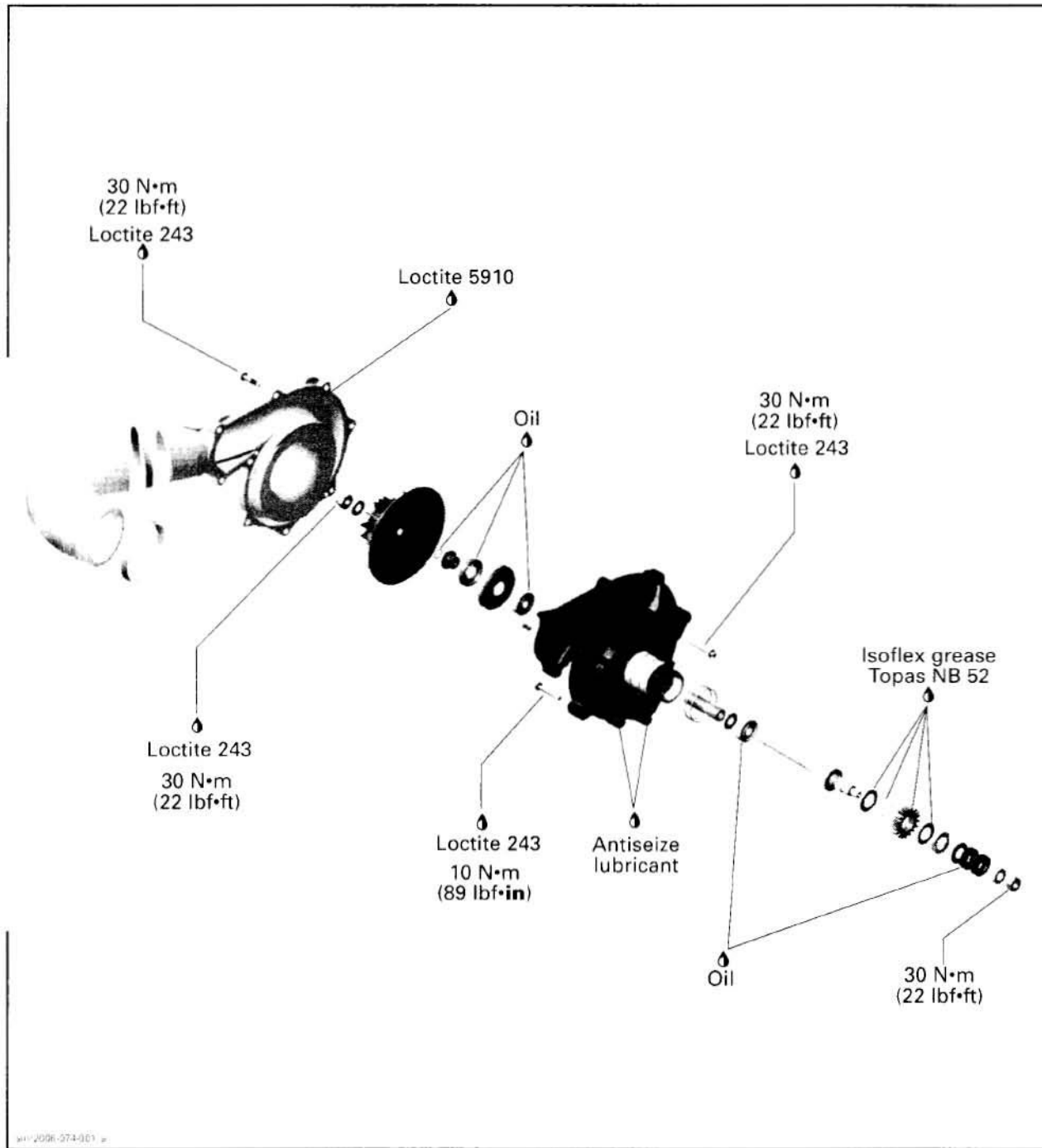

## INSPECTION (supercharger installed)

### Supercharger Inlet Cleanliness

**NOTE:** A lower than usual maximum RPM at full throttle might be caused by a dirty supercharger inlet.

Remove supercharger air inlet hose.

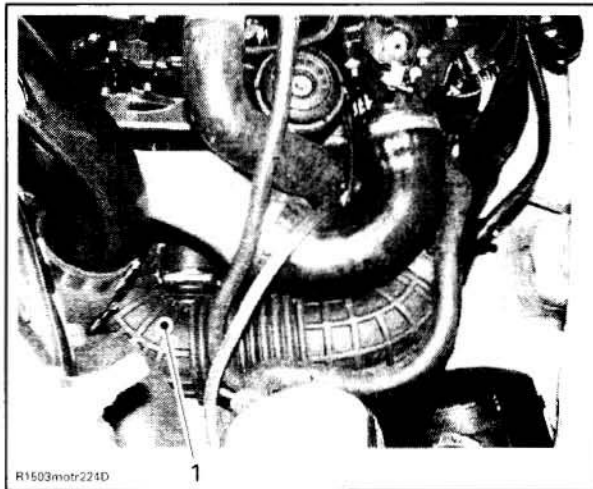

1. Air inlet hose

Visually inspect inside of inlet bore for oil, salt or any other deposits.

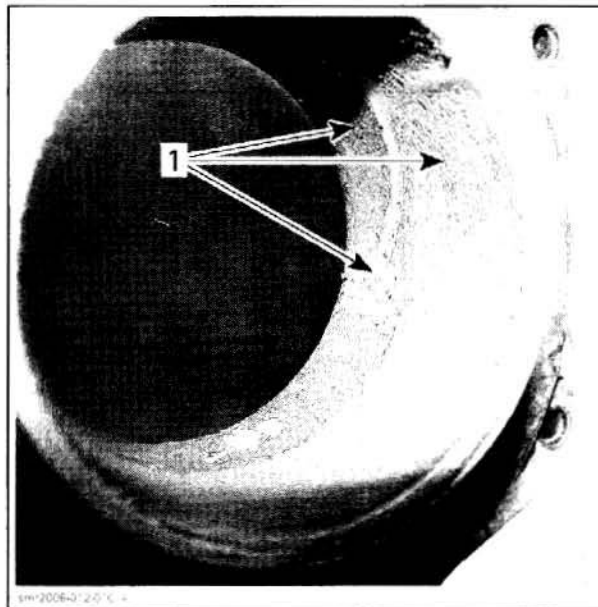

1. Dirt here

If dirt is found, proceed as follows.

Remove supercharger and perform the clutch slipping moment test. Inspect bearings and friction clutch. Replace bearings/clutch components as necessary.

Separate supercharger housing.

**NOTE:** Since supercharger is disassembled, it is recommended to completely inspect it.

Clean internal housing and impeller using a brush and cleaning solvent to get rid of oil deposits.

Blow dry with compressed air.

**CAUTION:** Do not let impeller spin when using compressed air.

Complete usual assembly procedures as described in this section.

### Supercharger Clutch Slipping Moment

As necessary, remove: seat, vent tube, coolant expansion tank and vent tube support.

Remove air inlet hose from supercharger.

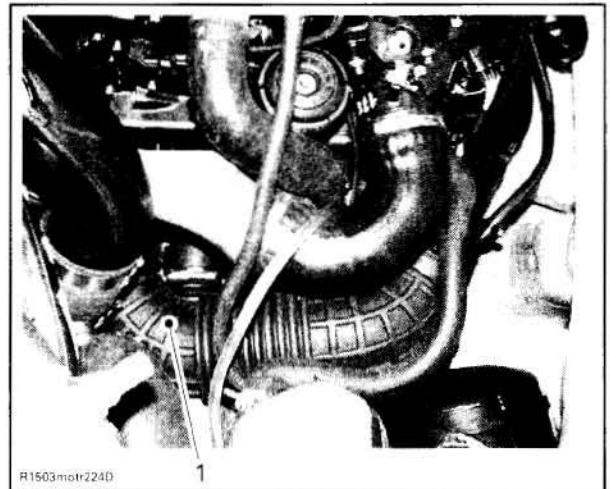

1. Inlet hose

Remove valve cover and install camshaft locking tool (P/N 529 035 839) to prevent camshaft rotation while checking slipping moment of supercharger. Refer to *CYLINDER HEAD*.

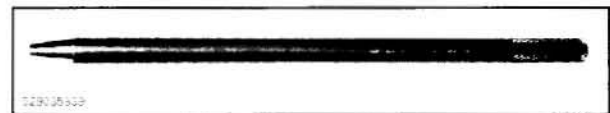

**NOTE:** Rotate supercharger nut to align camshaft holes and to allow insertion of the locking tool.

## INSPECTION (supercharger installed)

### Supercharger Inlet Cleanliness

**NOTE:** A lower than usual maximum RPM at full throttle might be caused by a dirty supercharger inlet.

Remove supercharger air inlet hose.

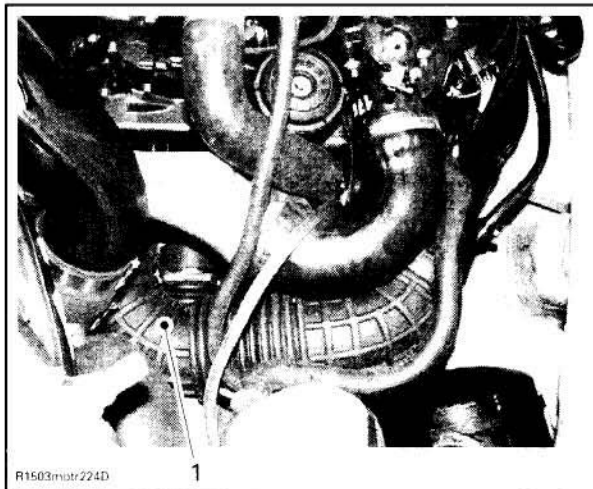

1 Air inlet hose

Visually inspect inside of inlet bore for oil, salt or any other deposits.

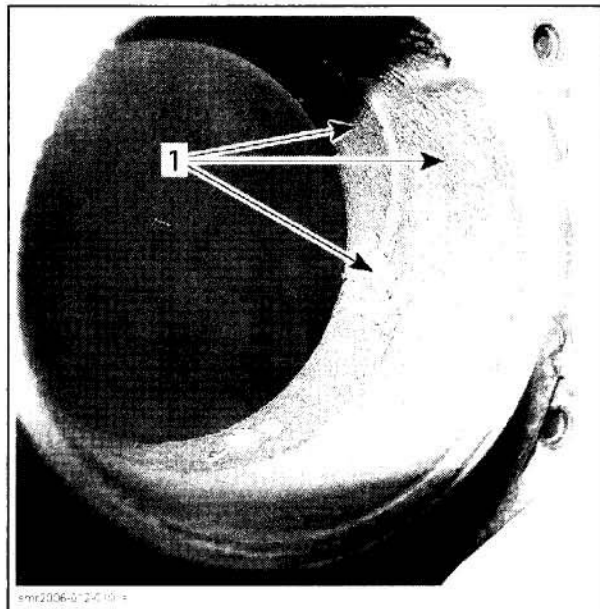

1: Dirt here

If dirt is found, proceed as follows.

Remove supercharger and perform the clutch slipping moment test. Inspect bearings and friction clutch. Replace bearings/clutch components as necessary.

Separate supercharger housing.

**NOTE:** Since supercharger is disassembled, it is recommended to completely inspect it.

Clean internal housing and impeller using a brush and cleaning solvent to get rid of oil deposits.

Blow dry with compressed air.

**CAUTION:** Do not let impeller spin when using compressed air.

Complete usual assembly procedures as described in this section.

### Supercharger Clutch Slipping Moment

As necessary, remove: seat, vent tube, coolant expansion tank and vent tube support.

Remove air inlet hose from supercharger.

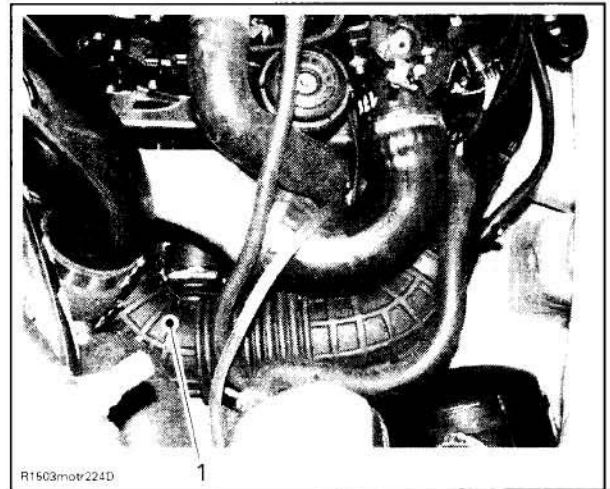

1: Inlet hose

Remove valve cover and install camshaft locking tool (P/N 529 035 839) to prevent camshaft rotation while checking slipping moment of supercharger. Refer to *CYLINDER HEAD*.



**NOTE:** Rotate supercharger nut to align camshaft holes and to allow insertion of the locking tool.



## Section 03 ENGINE

### Subsection 05 (SUPERCHARGER)

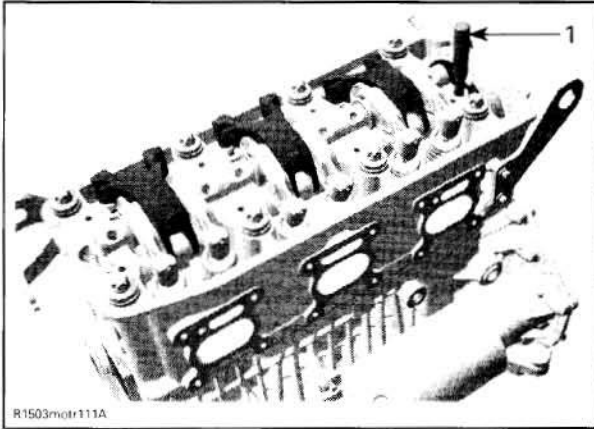

1. Camshaft locking tool

Check slipping moment counterclockwise by using a torque wrench with actual torque viewer. A mirror is useful to see the viewer.

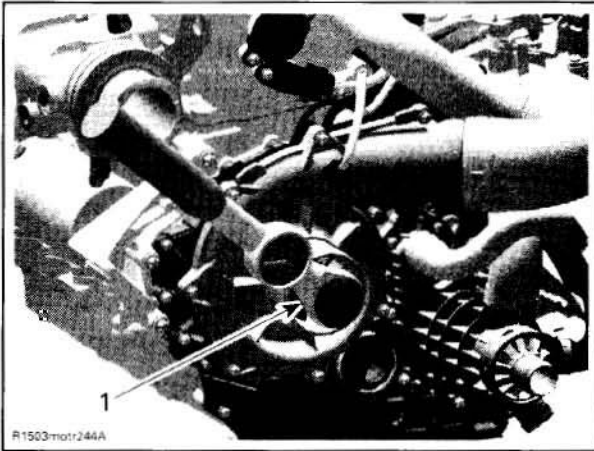

TYPICAL  
1. Torque wrench

**NOTE:** Before checking the supercharger slipping moment it is recommended to turn the clutch a full revolution. This way the parts can mate together and you will get a more accurate reading.

Supercharger should start to turn at a torque within the specified values.

SLIPPING MOMENT	NEW SUPERCHARGER	BREAK-IN SUPERCHARGER
Torque value applied	7 - 12 N•m (62 - 106 lbf•in)	5 - 10 N•m (44 - 88 lbf•in)

**NOTE:** After supercharger ran for a few hours, the parts break-in and this brings a reduced slipping moment.

If the torque is not within specifications, repair supercharger clutch. Verify supercharger clutch components as per *INSPECTION (PARTS DISASSEMBLED)* further in this section.

## REMOVAL

As necessary, remove: seat, vent tube, coolant expansion tank and vent tube support.

Remove air inlet and outlet hoses from supercharger.

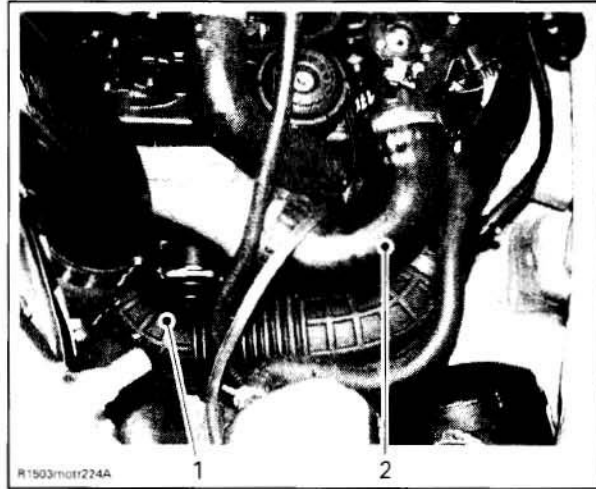

1. Air inlet hose  
2. Air outlet hose

Remove retaining screws and pull out the supercharger.

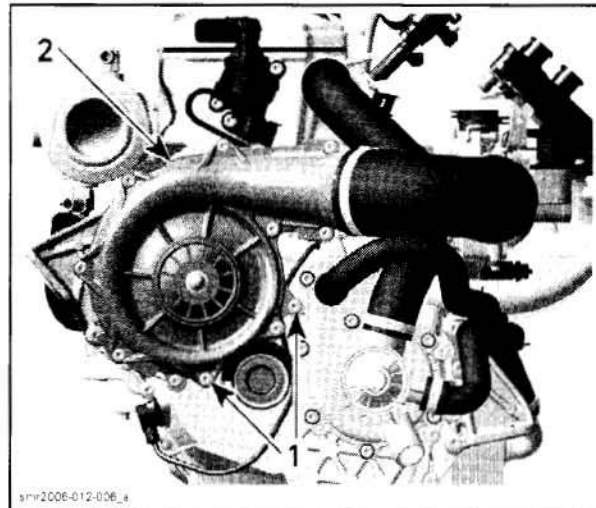

1. Retaining screws  
2. Upper retaining screw (hidden behind the supercharger)

To remove the upper screw (not shown on the picture above), use the Torx adapter (P/N 529 035 938).

**Section 03 ENGINE**  
**Subsection 05 (SUPERCHARGER)**

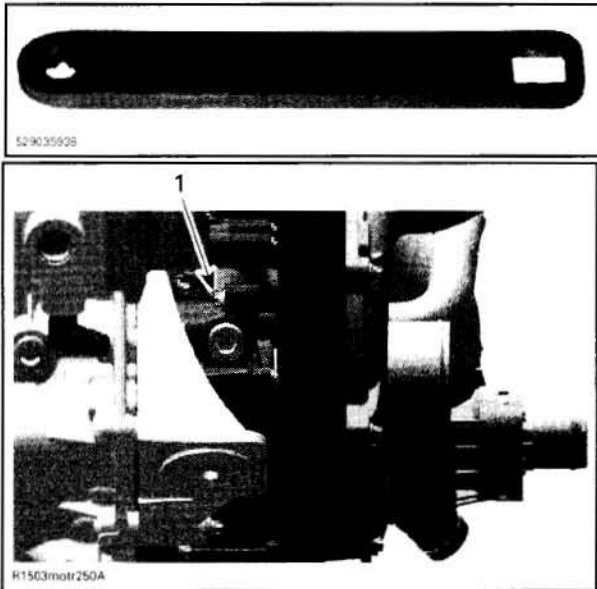

1. Upper retaining screw

**DISASSEMBLY**

**CAUTION:** Be scrupulous when working on supercharger parts. Supercharger rotation reaches 45 000 RPM. Any modification, improper repair/assembly or damage on the parts, may result in damage of the supercharger. Strictly follow the described procedures.

Take apart supercharger housing.

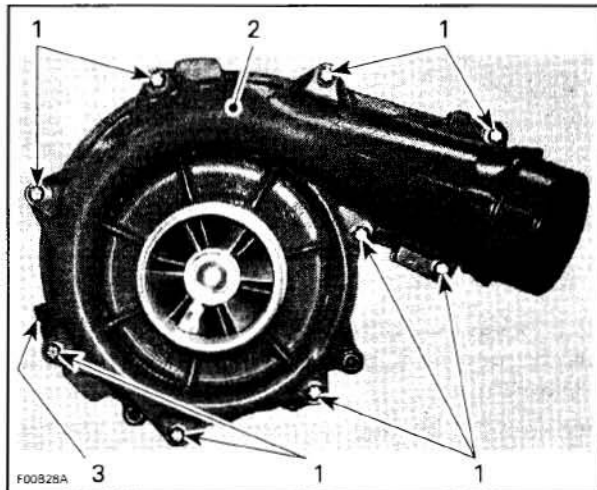

1. Retaining screws  
 2. Housing half (intake side)  
 3. Housing half (engine side)

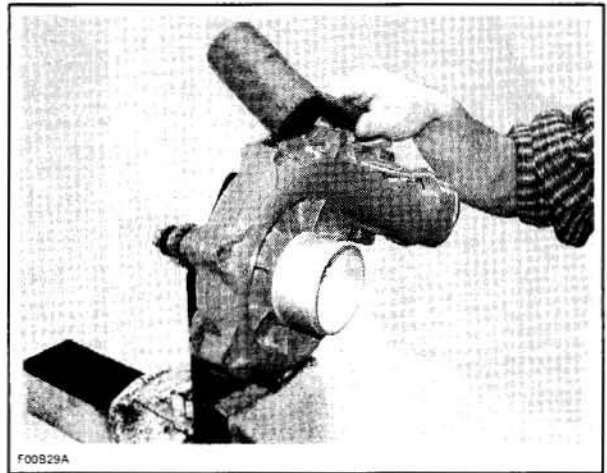

PLASTIC HAMMER

**NOTE:** The cap nut on the supercharger shaft has LH threads.

Loosen cap nut (turn clockwise) on supercharger shaft turbine side while holding shaft with a retaining key (P/N 529 036 027).

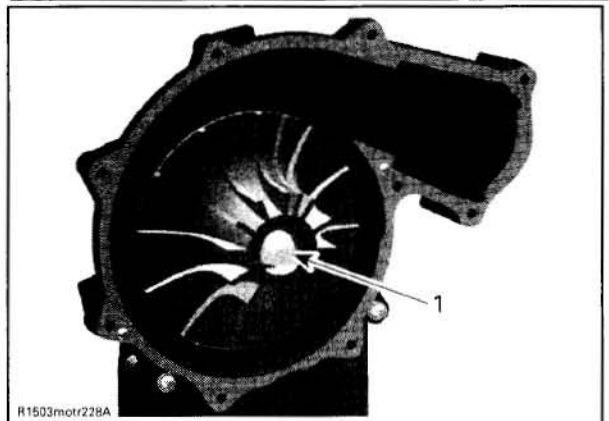
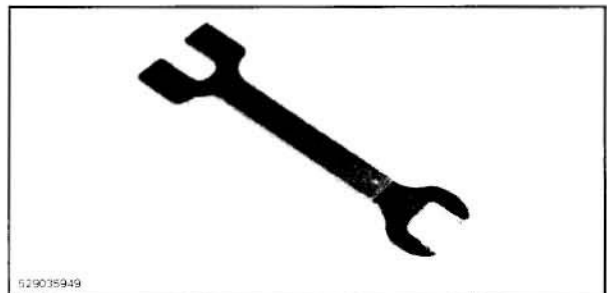

1. Cap nut

Remove washer, turbine, O-ring and step collar from supercharger shaft.



**Section 03 ENGINE**  
**Subsection 05 (SUPERCHARGER)**

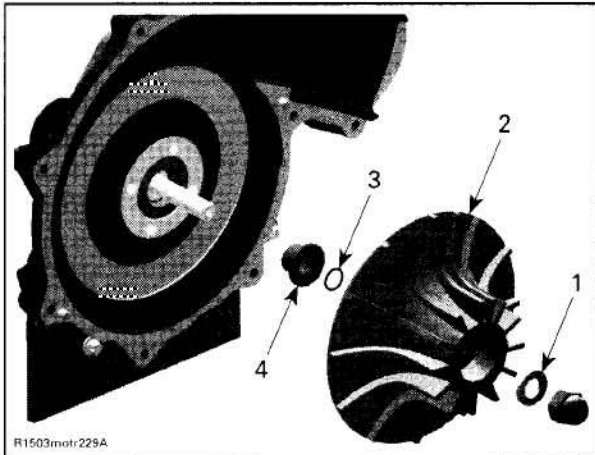

- 1. Washer
- 2. Turbine
- 3. O-ring
- 4. Step collar

Loosen nut on supercharger shaft engine side while holding shaft with a retaining key (P/N 529 036 027).

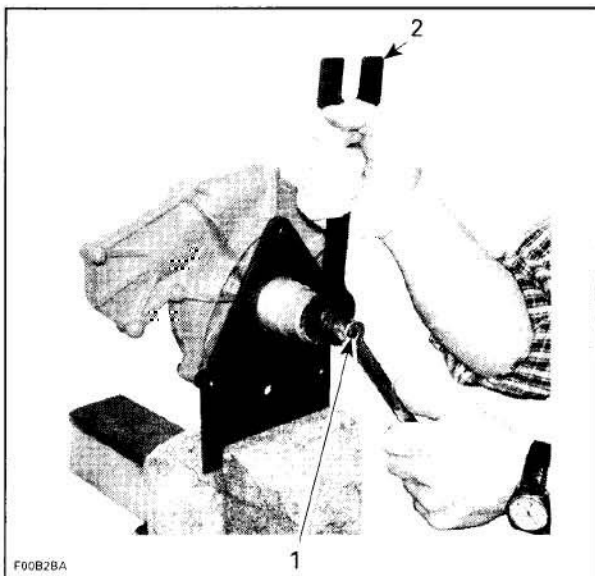

- 1. Nut
- 2. Retaining key

**NOTE:** There are 40 loose needle bearings under the gear. Do not reuse.

Remove L-ring, spring washers, lock washer, drive gear and needle pins by turning the supercharger upside down.

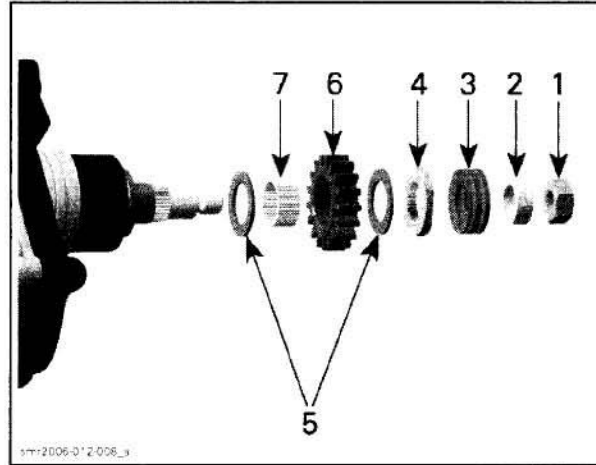

- 1. Nut
- 2. L-ring
- 3. Spring washers
- 4. Lock washer
- 5. Ceramic washers
- 6. Drive gear
- 7. Needle bearings

Carefully push out supercharger shaft towards engine side by using a press.

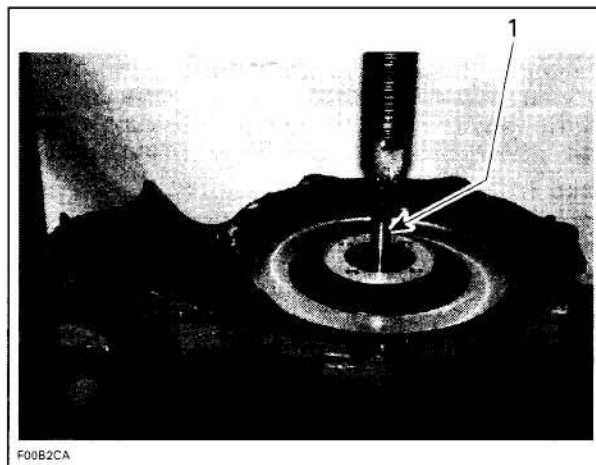

- 1. Supercharger shaft

**CAUTION:** Every time when removing the supercharger shaft, both ball bearings have to be replaced.

Remove ball bearing from supercharger shaft by using a press and retaining key (P/N 529 036 027).



**Section 03 ENGINE**  
**Subsection 05 (SUPERCHARGER)**

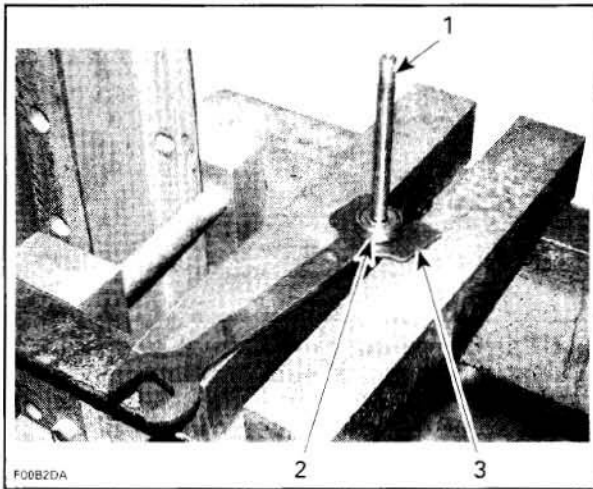

- 1. Supercharger shaft
- 2. Ball bearing
- 3. Retaining key

Screw out retaining disc with seal from housing half (engine side) by using the 4-pin socket (P/N 529 035 948).

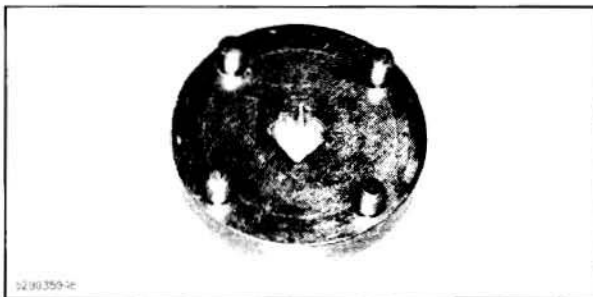

**NOTE:** It may be necessary to heat the housing with a heat gun to release the retaining disc.

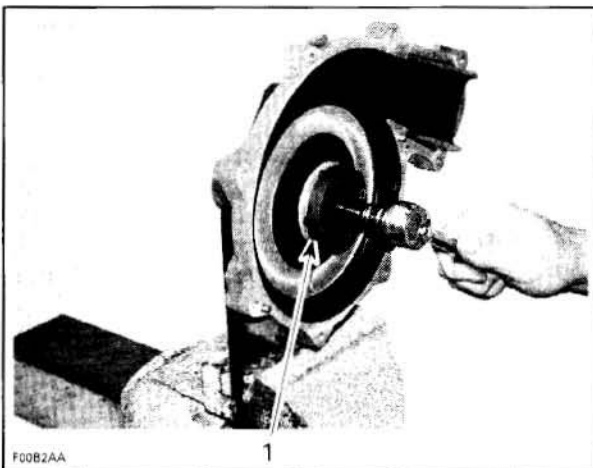

- 1. 4-pin socket

Remove ball bearing from supercharger housing half (engine side) by using a press and a suitable bearing pusher.

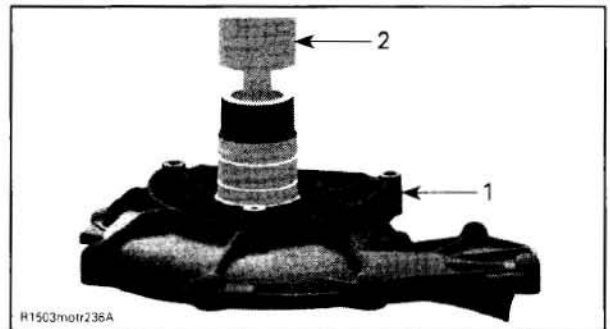

- 1. Supercharger housing half (engine side)
- 2. Bearing pusher

**PARTS INSPECTION**

**Supercharger Clutch Components and Gear**

Replace worn parts by new ones. A clutch repair kit is available. If all parts are within specifications, replace the 40 needle bearings and spring washer package on supercharger shaft.

**NOTE:** Ceramic washers are not affected by wear. Check the wear limit on drive gear, lock washer and driven plate on supercharger shaft. Check drive gear for cracks.

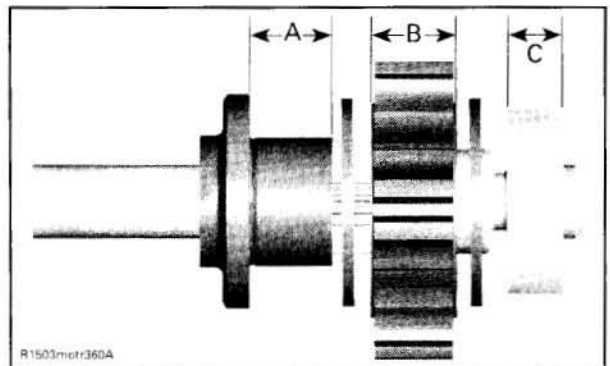

- A. Driven plate journal depth
- B. Drive gear thickness
- C. Lock washer thickness

DRIVEN PLATE JOURNAL DEPTH	
NEW MINIMUM	12.460 mm (0.4905 in)
NEW MAXIMUM	12.500 mm (0.4921 in)
SERVICE LIMIT	12.800 mm (0.5039 in)

DRIVE GEAR THICKNESS	
NEW MINIMUM	11.000 mm (.4331 in)
NEW MAXIMUM	11.050 mm (.4350 in)
SERVICE LIMIT	10.700 mm (.4251 in)

## Section 03 ENGINE

### Subsection 05 (SUPERCHARGER)

LOCK WASHER THICKNESS	
NEW MINIMUM	4.050 mm (.1594 in)
NEW MAXIMUM	4.150 mm (.1633 in)
SERVICE LIMIT	3.800 mm (.1496 in)

#### Spring Washer

Put spring washer package together as it is assembled on the supercharger shaft. Measure the height of the unloaded spring washer package.

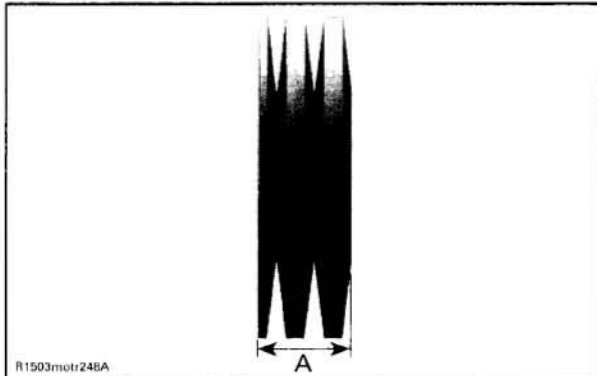

A. Spring washer package height

SPRING WASHER PACKAGE HEIGHT	
NEW	10.500 mm (.4134 in)
SERVICE LIMIT	9.700 mm (.3819 in)

## ASSEMBLY

Assembly is essentially the reverse of removal procedures. However pay particular attention to the following.

**CAUTION:** Every time when supercharger shaft has been removed, both ball bearings have to be replaced.

**CAUTION:** Both ball bearings have to be installed with cages facing supercharger impeller side.

Apply enough engine oil on ball bearing. Install ball bearing on supercharger shaft by using support plate (P/N 529 035 947) to hold bearing.



**CAUTION:** Ensure to position ball bearing against protrusion of support plate for the installation. This way, the installation pressure will be applied to the inner race and will not be transmitted to the bearing balls which would otherwise shorten the bearing life.

**CAUTION:** To install ball bearings and supercharger shaft always use a press, never use any beating force like a hammer.

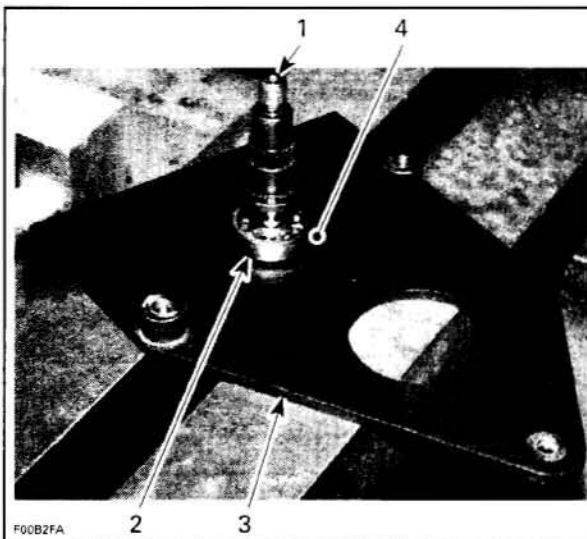

1. Supercharger shaft
2. Ball bearing
3. Bearing support plate
4. Protrusion of support plate on this side (underneath inner race)

Apply enough engine oil on ball bearing. Press in the ball bearing in supercharger housing half (engine side), by using ball bearing support/pusher (P/N 529 035 950).





**Section 03 ENGINE**  
**Subsection 05 (SUPERCHARGER)**

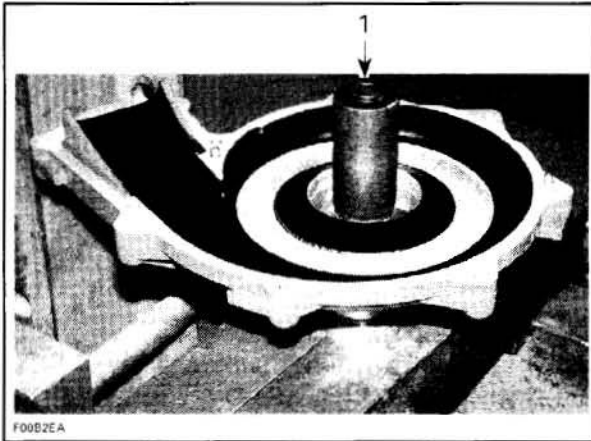

1. Bearing support/pusher

Mount supercharger housing half (engine side) on support plate (P/N 529 035 947).

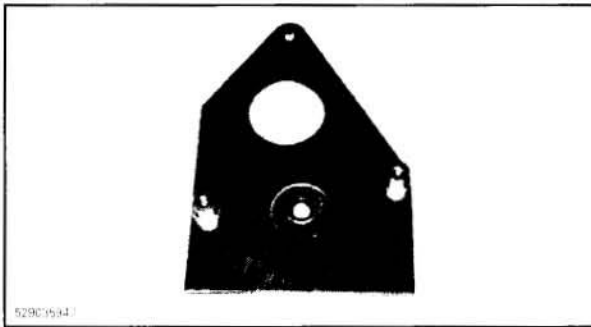

Apply Loctite 243 (P/N 293 800 060) on retaining disc and install it in supercharger housing half by using the 4-pin socket (P/N 529 035 948). Torque to 30 N•m (22 lbf•ft).

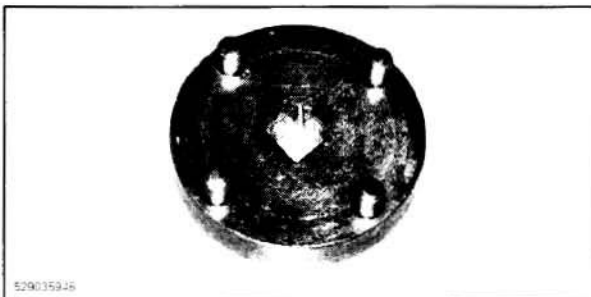

**NOTE:** If a new disc is installed, do not use any Loctite, threadlocker is already applied.

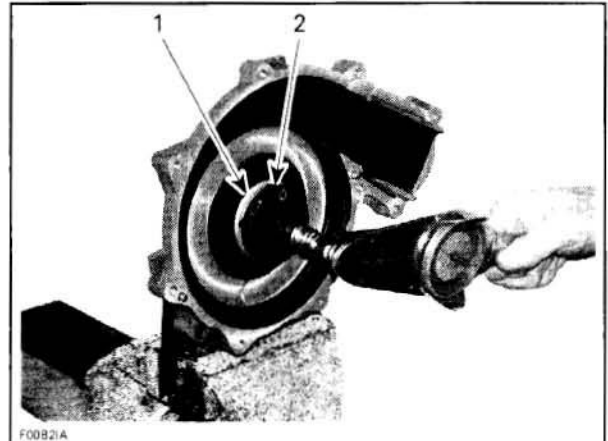

1. Retaining disc  
 2. 4-pin socket

To press supercharger shaft in housing half (engine side), properly support bearing, using support plate (P/N 529 035 947) and bearing support/pusher (P/N 529 035 950) under supercharger housing half.

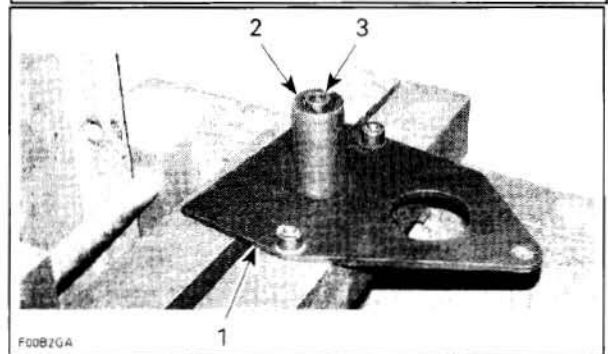
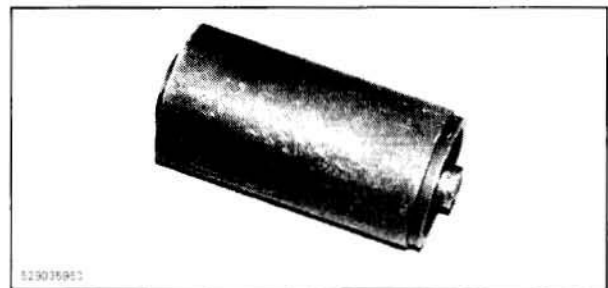

1. Support plate  
 2. Bearing support/pusher  
 3. Protrusion here

**CAUTION:** Before pressing in the supercharger shaft, be sure to properly support the inner race of ball bearing in supercharger housing half with the recommended tool. This way, the installation pressure will be applied to the inner race and will not be transmitted to the bearing balls which would otherwise shorten the bearing life.



## Section 03 ENGINE

### Subsection 05 (SUPERCHARGER)

Apply heat outside of the housing with a heat gun to expand its diameter prior to inserting the shaft. Ensure there is no O-ring on the housing half prior to heating.

Apply engine oil on supercharger shaft. Press shaft with thrust washer and distance sleeve together in supercharger housing half.

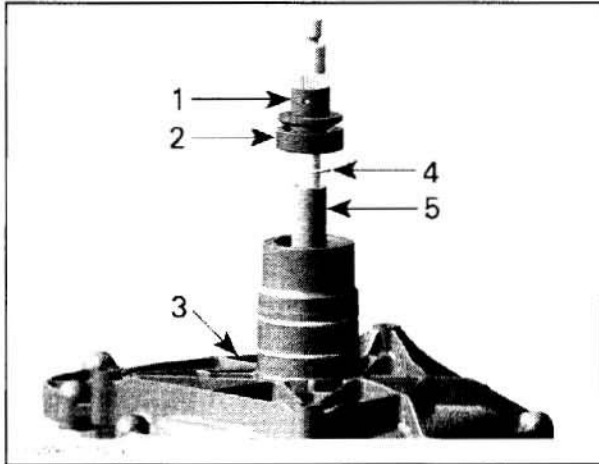

- 1 Compressor shaft
- 2 Ball bearing
- 3 Supercharger housing half
- 4 Thrust washer
- 5 Distance sleeve

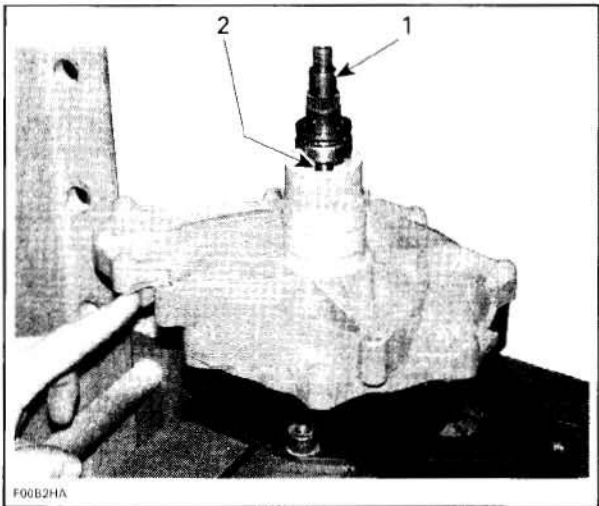

- 1 Supercharger shaft
- 2 Distance sleeve

Apply engine oil on seal and push into retaining disc by hand.

**NOTE:** Always use a new oil seal when assembling the supercharger.

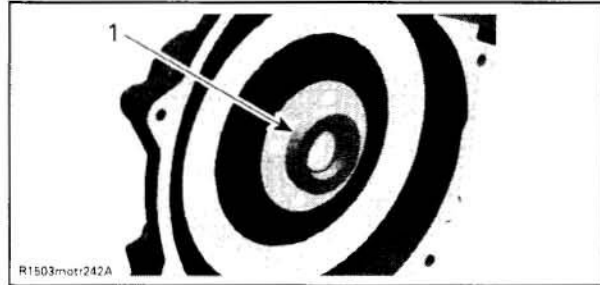

- 1 Oil seal

Install step collar, O-ring, supercharger impeller and washer on supercharger shaft. Apply Loctite 243 (P/N 293 800 060) on cap nut and temporary finger tight cap nut.

**NOTE:** The cap nut on the supercharger shaft has a left-handed thread. The Loctite has to be applied in a small dose into the nut.

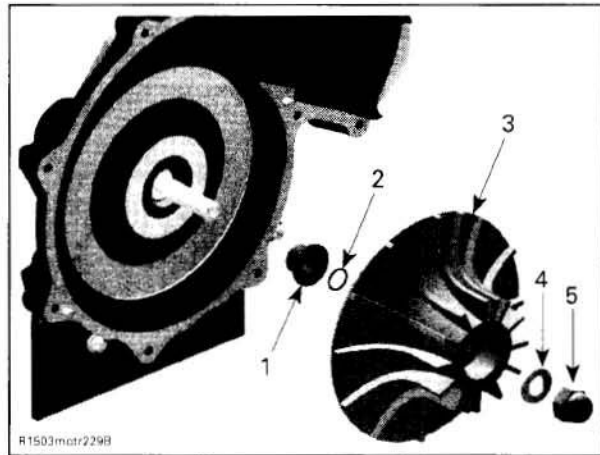

- 1 Step collar
- 2 O-ring
- 3 Supercharger impeller
- 4 Washer
- 5 Cap nut

Complete installation of supercharger shaft, engine side as follows:

**CAUTION:** It is of the utmost importance that all parts be absolutely clean. The compressor shaft spins at up to 45 000 RPM and any debris could cause a failure.

Install the first ceramic washer.

**NOTE:** The ceramic washers differ in their inner diameter. Install first the ceramic washer with the bigger inner diameter. The ceramic washer with the smaller inner diameter will be installed on the lock washer side.

**CAUTION:** Manipulate ceramic washers with care, those parts are fragile.

**Section 03 ENGINE**  
**Subsection 05 (SUPERCHARGER)**

**IMPORTANT:** Apply Kluber Isoflex grease (P/N 293 550 021) to the inner diameter of the gear thrust surface on the shaft, ceramic washers, needle bearings shaft surface and lock washer.

**CAUTION:** No other grease can be used, otherwise damage to bearings will occur.

Install the 40 needle bearings on the compressor shaft.

**NOTE:** The 40 needle bearings comes in a wax strip with an adhesive backing.

Remove the adhesive backing.

Install the drive gear over the needle bearings.

Install the other ceramic washer (ceramic washer with smaller inner diameter).

Install the lock washer.

Apply engine oil to the spring washers.

Position the spring washers as per illustration.

**CAUTION:** When installing the spring washers, take care of the exact installation direction of the washers.

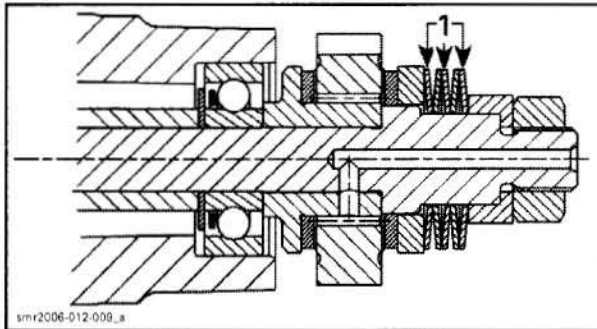

1. Spring washers

Install the L-ring on the compressor shaft.

Apply Loctite 243 (P/N 293 800 060) on the hexagonal nut threads. Torque to 30 N•m (22 lbf•ft).

**NOTE:** The L-ring will pre-load the spring washers.

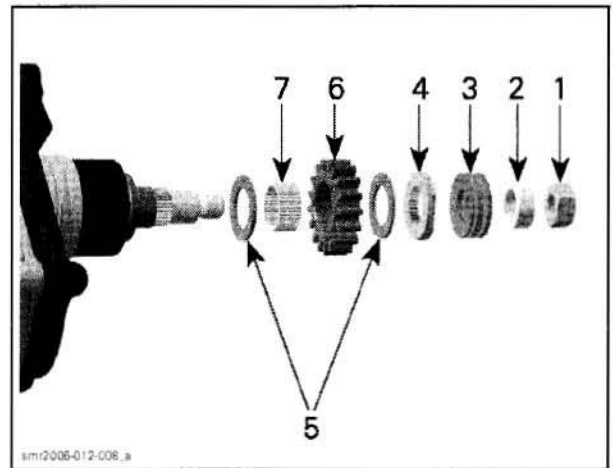

1. Nut
2. L-ring
3. Spring washers
4. Lock washer
5. Ceramic washers
6. Drive gear
7. Needle bearings

Hold the lock washer of the supercharger shaft (engine side) using the retaining key (P/N 529 036 027).

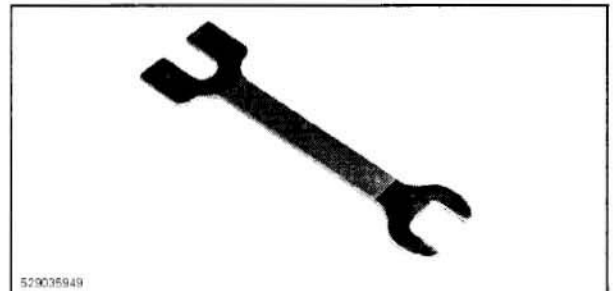

Tighten the impeller cap nut to 30 N•m (22 lbf•ft).

Apply Loctite 5910 (P/N 293 800 081) on supercharger housing sealing surface.

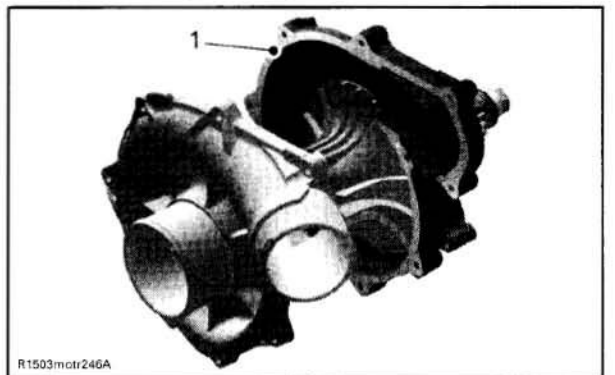

1. Apply Loctite 5910 on sealing surface

Assemble supercharger housing halves. Apply Loctite 243 (P/N 293 800 060) on retaining screws and torque to 10 N•m (89 lbf•in) according to the following sequence.



**Section 03 ENGINE**  
**Subsection 05 (SUPERCHARGER)**

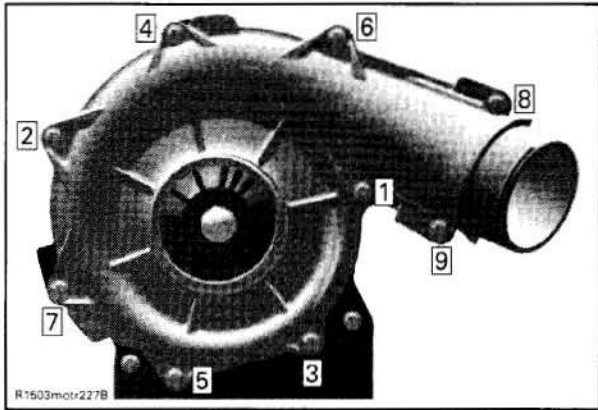

**SUPERCHARGER TIGHTENING SEQUENCE**

Use gear holder (P/N 529 036 025) to retain supercharger gear while measuring slipping moment.

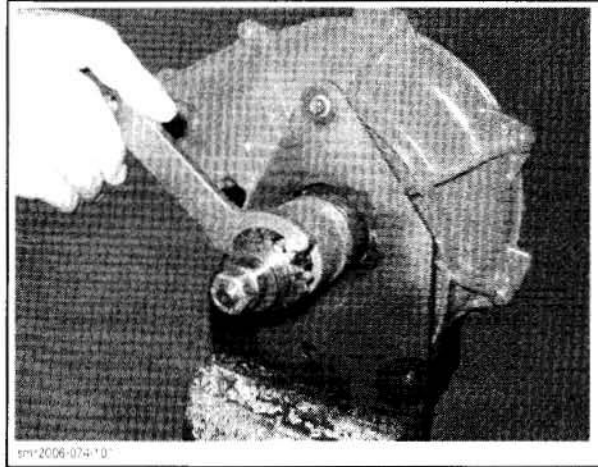
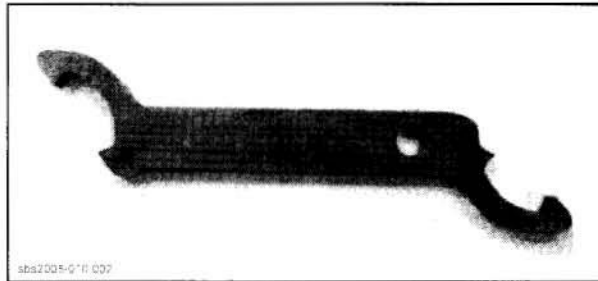

Check slipping moment counterclockwise by using a torque wrench with a viewer.

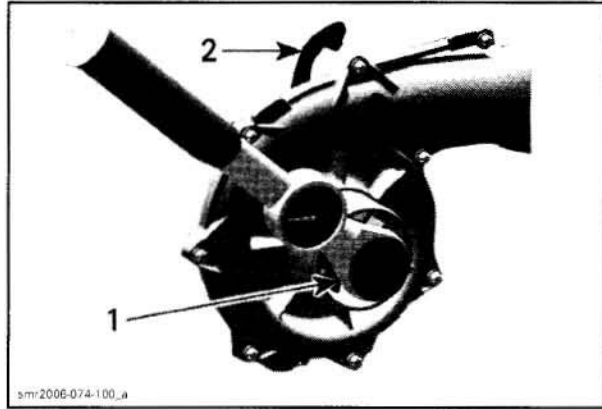

- 1. Torque wrench
- 2. Gear holder

**NOTE:** Before checking the supercharger slipping moment it is recommended to turn the clutch a full revolution. This way the parts can mate together and you will get a more accurate reading.

Supercharger should start to turn at a torque within the specified values.

SLIPPING MOMENT	NEW SUPERCHARGER	BREAK-IN SUPERCHARGER
Torque value applied	7 - 12 N•m (62 - 106 lbf•in)	5 - 10 N•m (44 - 88 lbf•in)

**NOTE:** After supercharger ran for a few hours, the parts break-in and this brings a reduced slipping moment.

If the torque is not within specifications, check single components of supercharger clutch.

**INSTALLATION**

Sealing surface between supercharger and PTO housing has to be greased with Super Lube grease (P/N 293 550 030).



**Section 03 ENGINE**  
**Subsection 05 (SUPERCHARGER)**

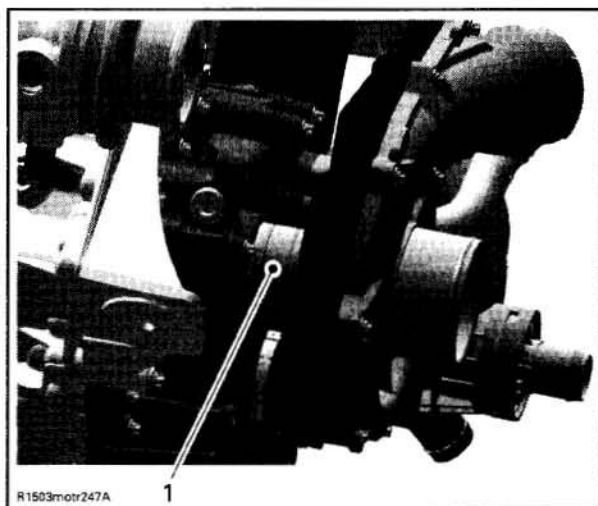

1. Super Lube grease

Lubricate bearings with engine oil before installation of supercharger in PTO housing.

Install supercharger on PTO housing. Apply Loctite 243 (P/N 293 800 060) on the retaining screws.

Torque screws to 10 N•m (89 lbf•in).

To tighten and torque the upper screw, use the Torx adapter (P/N 529 035 938).

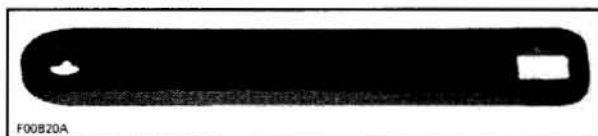

Ensure to install the tool perpendicularly (90°) to torque wrench to apply the proper torque to the screw.

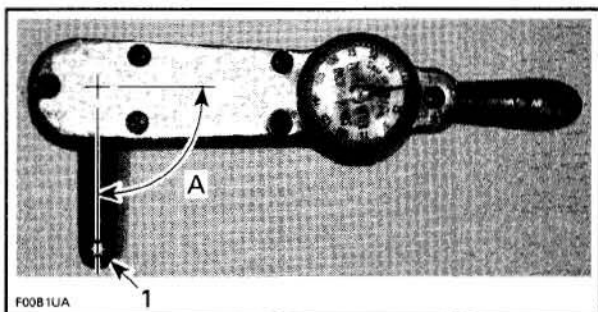

1. Tool perpendicular (90°) to torque wrench  
A. 90°

**CAUTION:** Not installing the tool as shown will change the torque applied to the screw. Proper torque and tightening sequence are important.

After complete installation of the supercharger, the slipping moment has to be rechecked. Refer to *INSPECTION (SUPERCHARGER INSTALLED)* at the beginning of this section.

# EXHAUST SYSTEM

## SERVICE TOOLS

<b>Description</b>	<b>Part Number</b>	<b>Page</b>
flushing connector adaptor .....	295 500 473 .....	72
small hose pincher.....	295 000 076 .....	73
spring installer/remover .....	529 035 989 .....	74

## SERVICE PRODUCTS

<b>Description</b>	<b>Part Number</b>	<b>Page</b>
high temperature RTV sealant .....	293 800 090 .....	75
Loctite 518.....	293 800 038 .....	77
Loctite silicone sealant (clear).....	293 800 086 .....	79

**COMPONENTS**

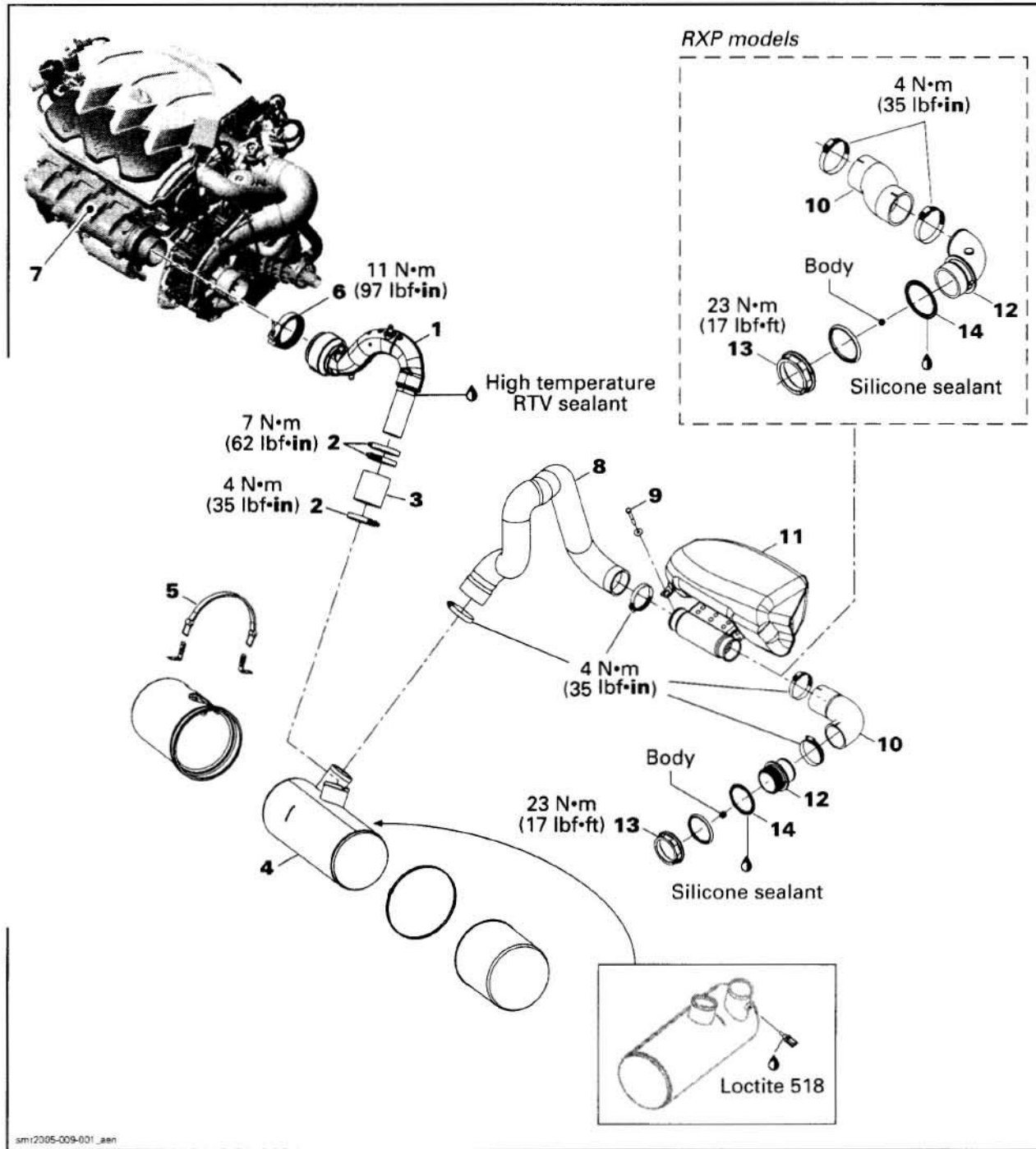



**GENERAL**

**EXHAUST SYSTEM COOLING**

Water Flow in the Exhaust System  
*GTI 4-TEC, GTX 4-TEC and WAKE*

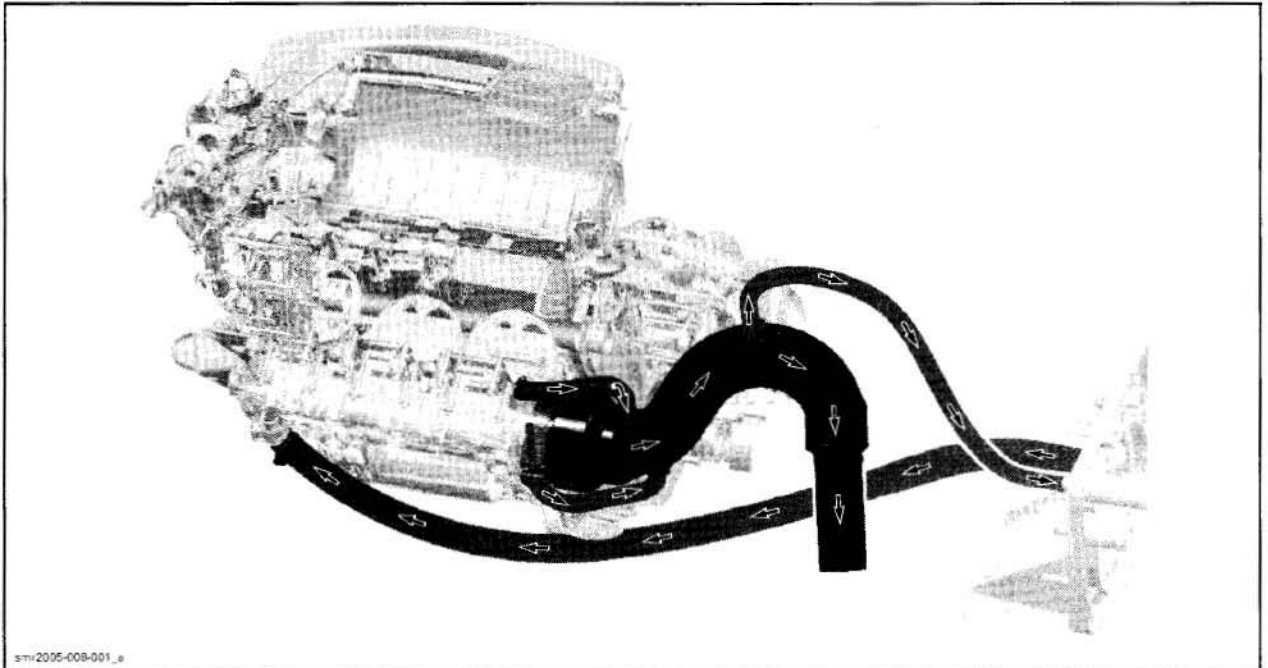

***GTX 4-TEC Supercharged***

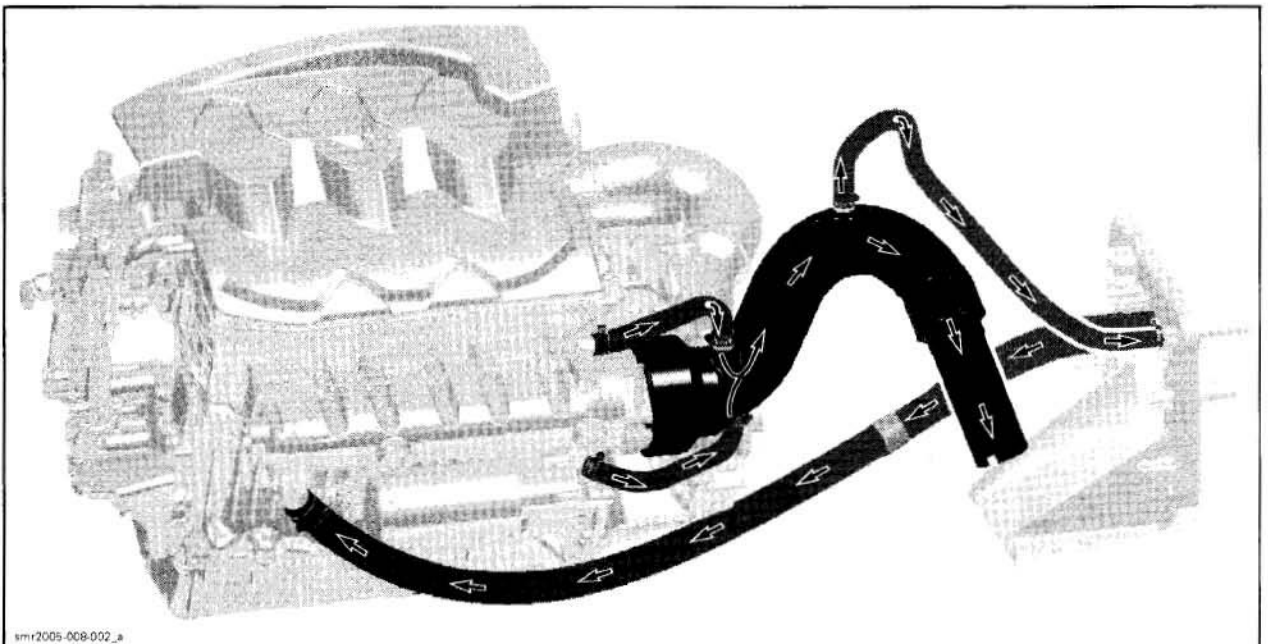

**Section 03 ENGINE**  
Subsection 06 (EXHAUST SYSTEM)

**GTX 4-TEC Limited and RXT**

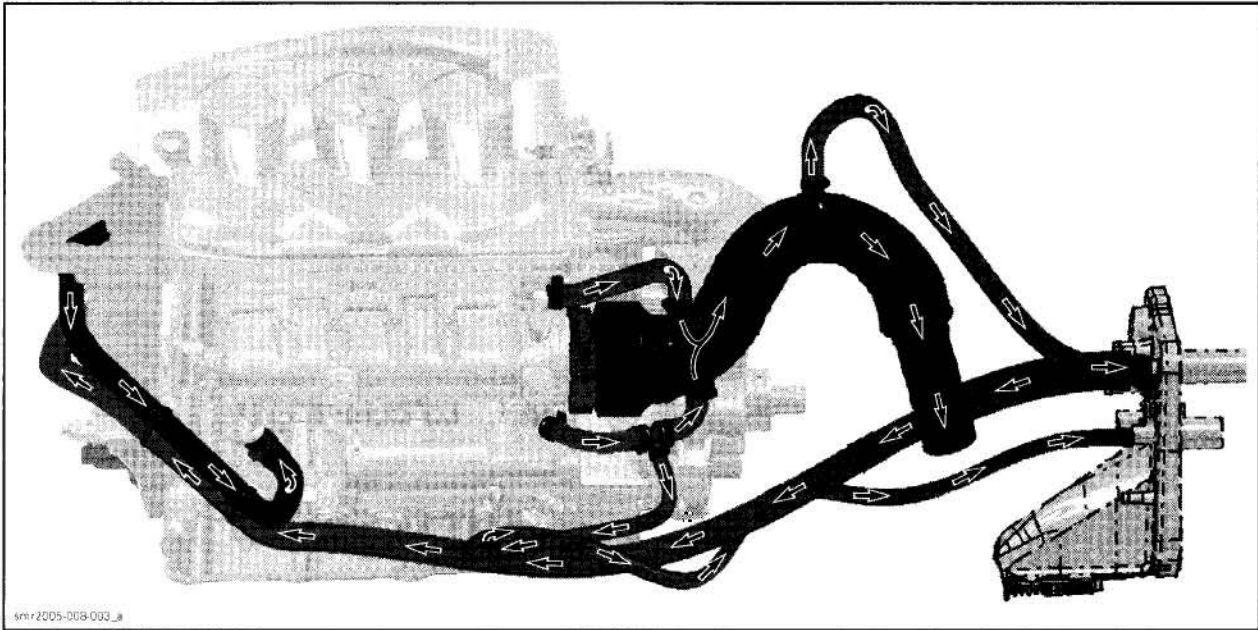

**RXP**

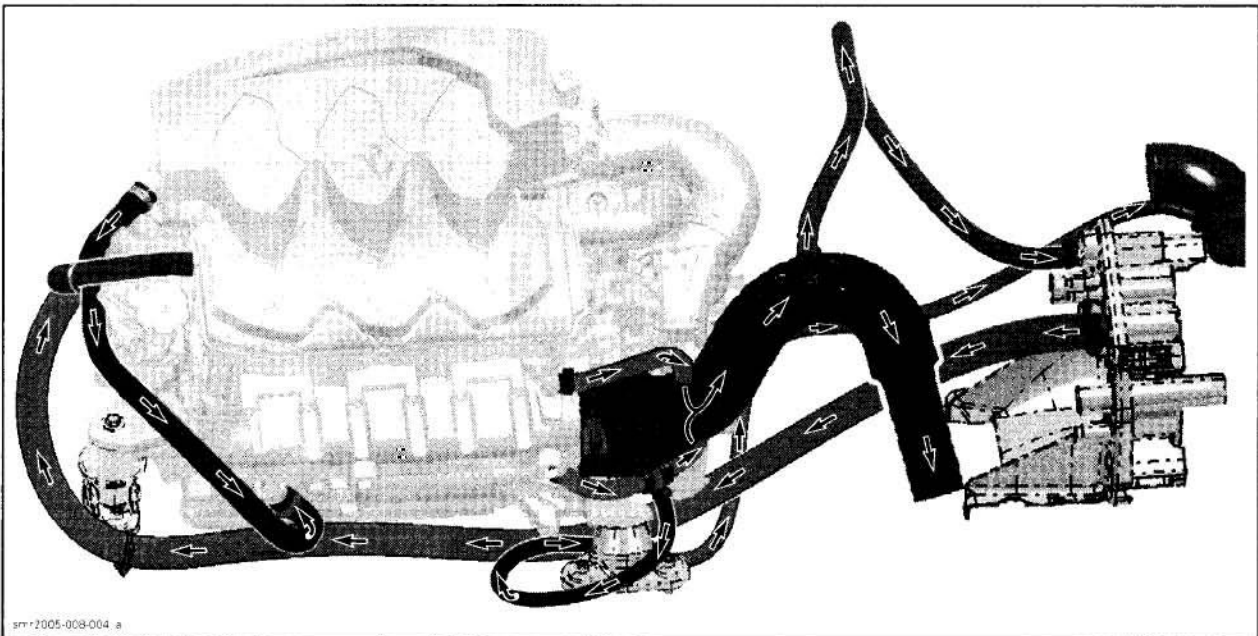



**Section 03 ENGINE**  
**Subsection 06 (EXHAUST SYSTEM)**

**Overview**

The exhaust system is protected by its own cooling system, an opened loop type.

The water supply is provided by a pressurized area in the jet pump between the impeller and venturi.

The water flow is controlled by a reducer located between the jet pump support and the jet pump on the inlet side. The reducer is color coded according to watercraft model. Refer to *JET PUMP*.

Water is directed first through the intercooler or to the exhaust manifold fitting located at front of manifold for the models without intercooler.

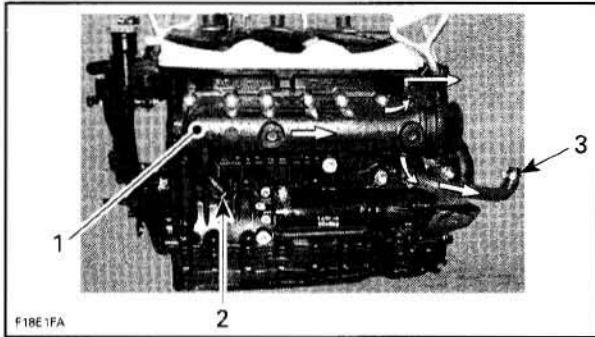

**TYPICAL — MODELS WITHOUT INTERCOOLER**  
 1. Exhaust manifold  
 2. Water inlet  
 3. Water outlet

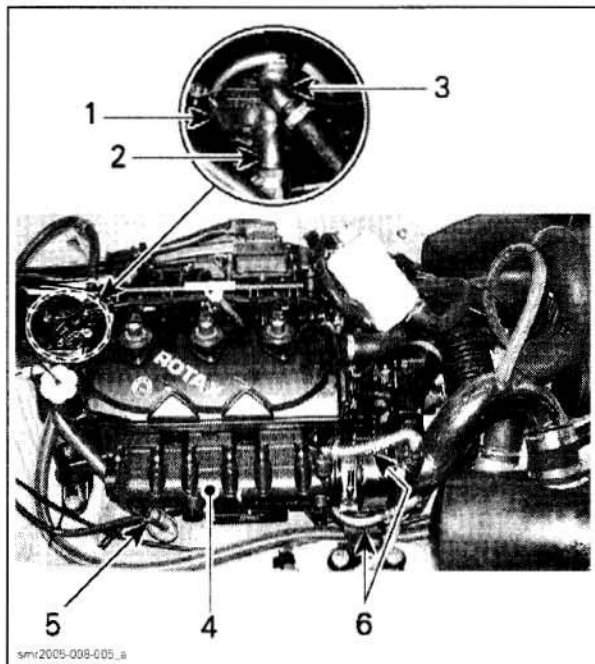

**TYPICAL — MODELS WITH INTERCOOLER**  
 1. Intercooler  
 2. Water inlet  
 3. Toward exhaust manifold  
 4. Exhaust manifold  
 5. Water inlet (from intercooler)  
 6. Water outlet

Water enters the manifold end and is directed to water jackets of exhaust manifold.

Water exits exhaust manifold through 2 hoses at rear manifold.

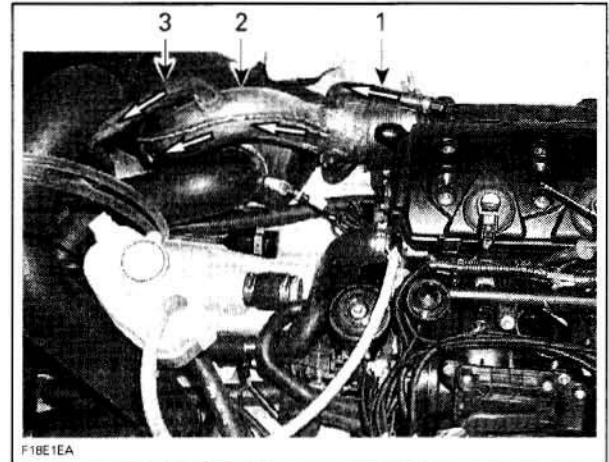

**TYPICAL**  
 1. Water coming from exhaust manifold  
 2. Exhaust pipe  
 3. Bleed hose

Water enters exhaust pipe and flows in the water jacket of pipe.

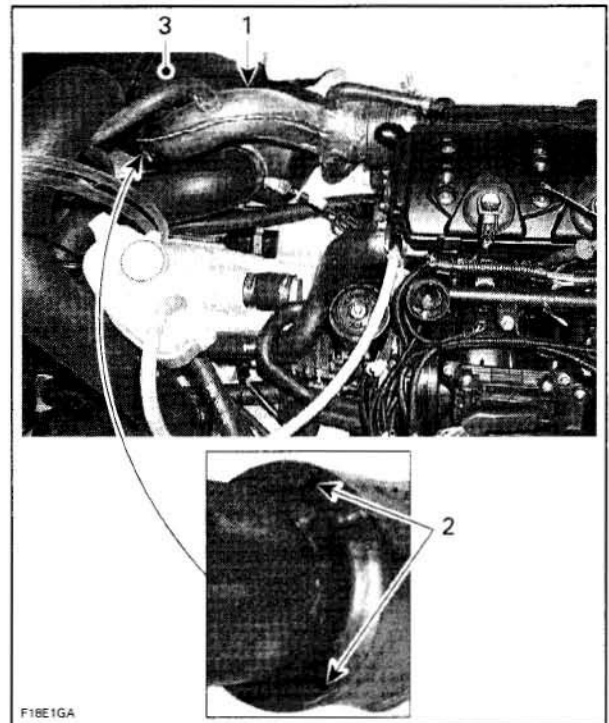

**TYPICAL**  
 1. Exhaust pipe  
 2. Outlet holes of exhaust pipe  
 3. Muffler



## Section 03 ENGINE

### Subsection 06 (EXHAUST SYSTEM)

Bleeding of the exhaust system is accomplished by the bleed hose located at the upper most point of the circuit of the exhaust pipe.

Water exits exhaust pipe through holes at the end of the water packet and mixes with exhaust gas in the muffler.

Water is expelled from mufflers then through the exhaust outlet in transom area.

#### Technical Specifications

TYPE	Total Loss Cooling System (TLCS).
WATER FLOW	Flow from jet pump (no water pump).
TEMPERATURE CONTROL	Calibrated outlet fittings (no thermostat).
SYSTEM BLEEDING	Self-bleed type (hose at uppermost point of circuit).
SYSTEM DRAINING	Self-drain type (hose at lowest point of circuit).

## MAINTENANCE

### EXHAUST SYSTEM FLUSHING

Flushing the exhaust system with fresh water is essential to neutralize corroding effects of salt or other chemical products present in water. It will help to clean up sand, salt, shells or other particles in water jackets (exhaust system and intercooler (if so equipped)) and/or hoses.

Exhaust system flushing should be performed when the watercraft is not expected to be used further the same day or when the watercraft is stored for any extended time.

**CAUTION:** Failure to flush the system, when necessary, will severely damage engine intercooler and/or exhaust system. Make sure engine operates during entire procedure.

#### **⚠ WARNING**

Perform these operations in a well ventilated area. Certain components in the engine compartment may be very hot. Direct contact may result in skin burn. Do not touch any electrical part or jet pump area when engine is running.

#### **⚠ WARNING**

When operating the engine while the watercraft is out of the water, the heat exchanger in the ride plate may become very hot. Avoid any contact with ride plate as burns may occur.

#### Procedure Using Flushing Connector on Jet Pump Support

Connect a garden hose to connector located at the rear of watercraft on jet pump support. Do not open water tap yet.

**NOTE:** The optional flushing connector adaptor (P/N 295 500 473) can be used with a quick connect adaptor to ease garden hose installation.

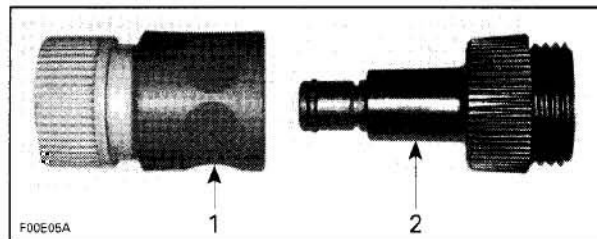

1. Quick connect adapter
2. Flushing connector adapter

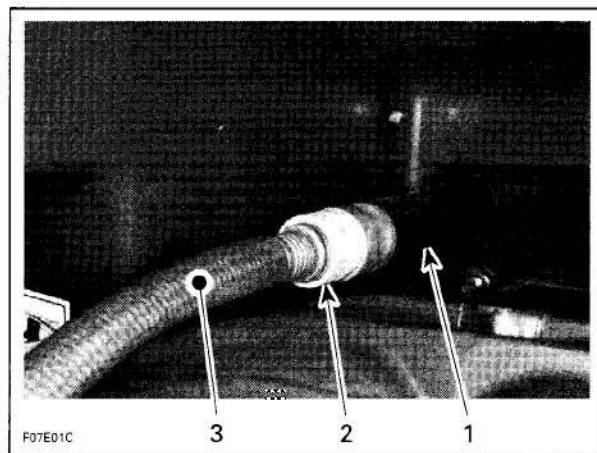

#### TYPICAL

1. Flushing connector
2. Quick connect adapter and flushing connector adapter (optional)
3. Garden hose

To flush the exhaust system, start the engine then immediately open the water tap.

**CAUTION:** Always start the engine before opening the water tap. Open water tap immediately after engine is started to prevent overheating.

**CAUTION:** Never run engine without supplying water to the exhaust system when watercraft is out of water.

**Section 03 ENGINE**  
**Subsection 06 (EXHAUST SYSTEM)**

Run the engine about 20 seconds at a fast idle between 4000 - 5000 RPM.

**CAUTION:** Never run engine longer than 2 minutes. Drive line seal has no cooling when watercraft is out of water.

Ensure water flows out of jet pump while flushing. Close the water tap, then stop the engine.

**CAUTION:** Always close the water tap before stopping the engine.

Disconnect the garden hose.

**CAUTION:** Remove flushing connector adapter after operation (if used).

**Procedure Using Flushing Connector in Engine Compartment**

**GTX Limited Models**

This flushing connector allows to flush the exhaust system directly by the engine compartment. The access is easier than the connector on the jet pump support but requires the use of a small hose pincher.

Remove seat to gain access.

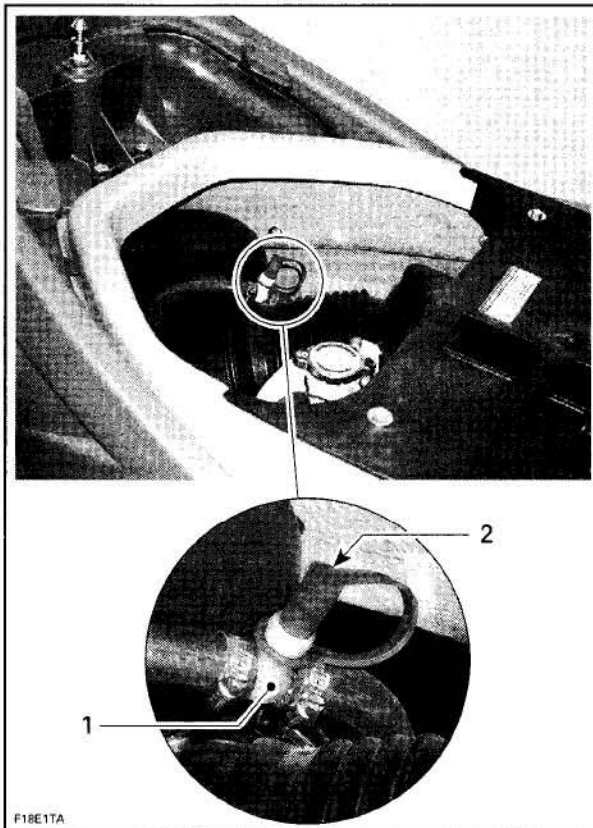

1. Flushing connector  
2. Dust cap

Remove dust cap from flushing connector and attach coupler hose (supplied with vehicle). Make sure coupler hose is properly locked to flushing connector.

Install a small hose pincher (P/N 295 000 076) (supplied inside vehicle tool kit) on water outlet hose. This prevent water from directly existing exhaust cooling system.

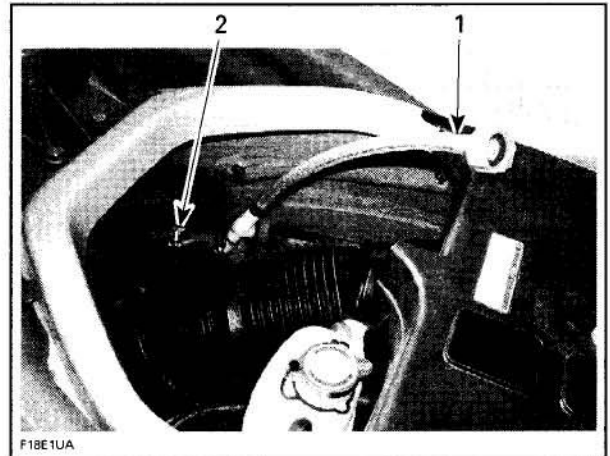
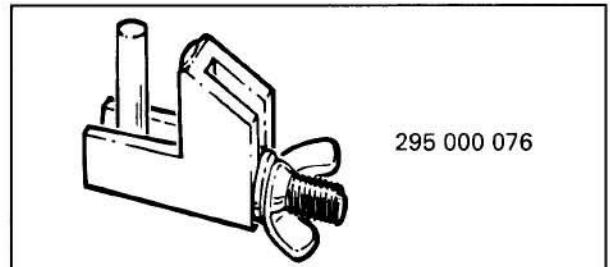

1. Coupler hose  
2. Small hose pincher

Attach other end of coupler hose to a garden hose. Do not open water tap yet.

To flush the exhaust cooling system, start the engine then immediately open the water tap.

**CAUTION:** Always start the engine before opening the water tap. Open water tap immediately after engine is started to prevent overheating.

**CAUTION:** Never run engine without supplying water to the exhaust system when watercraft is out of water.

Run the engine about 20 seconds at a fast idle between 4000 - 5000 RPM.

**CAUTION:** Never run engine longer than 2 minutes. Drive line seal has no cooling when watercraft is out of water.

Ensure water flows out of jet pump while flushing. Close the water tap, then stop the engine.



## Section 03 ENGINE

### Subsection 06 (EXHAUST SYSTEM)

**CAUTION:** Always close the water tap before stopping the engine.

Unlock and remove coupler hose. Reinstall dust cap over flushing connector.

Remove hose pincher from water outlet hose.

**CAUTION:** Serious damage to exhaust system can occur if hose pincher is not removed.

## PROCEDURES

### EXHAUST PIPE

#### Removal

#### **⚠ WARNING**

Certain components in the engine compartment may be very hot. Direct contact may result in skin burn. Let exhaust system cool down prior to removing parts.

#### **All Models except RXP**

Remove seat and seat extension.

Remove seat support (if so equipped).

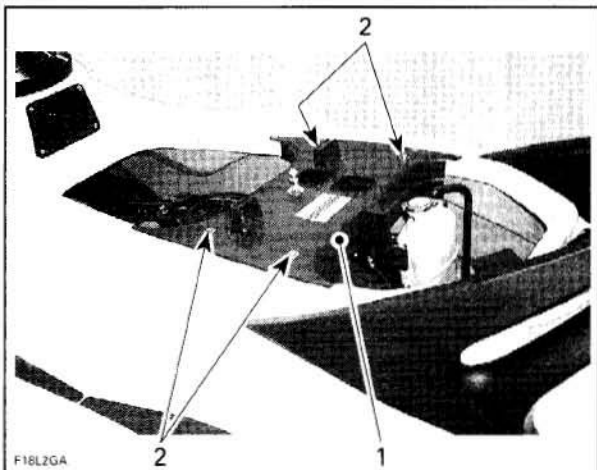

1. Seat support
2. Remove screws

#### **RXP Models**

Remove seat.

Remove engine cover. Refer to *HULL AND BODY*.

#### **All Models**

Disconnect the 3 cooling hoses from exhaust pipe no. 1.

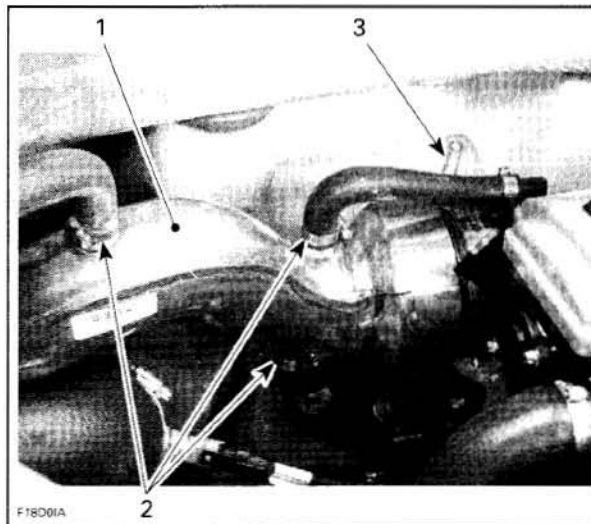

1. Exhaust pipe
2. Gear clamp
3. Exhaust clamp

Loosen the clamps no. 2 to the top portion of the muffler hose no. 3 between muffler no. 4 and the exhaust pipe no. 1.

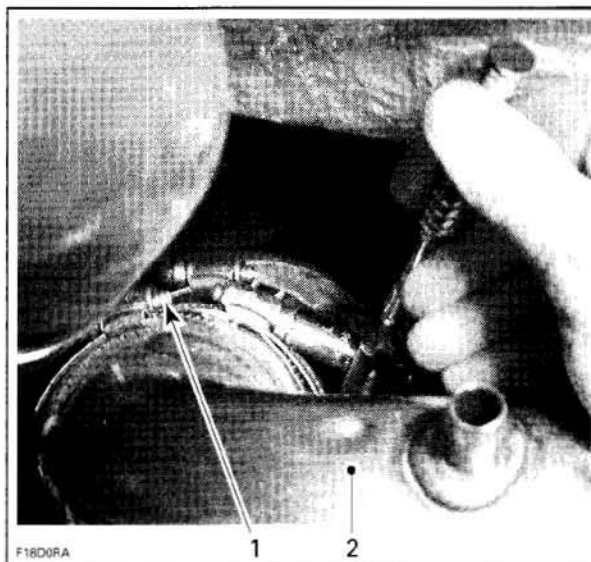

1. Muffler hose clamp
2. Exhaust pipe

Detach the strap no. 5 from the muffler using the spring installer/remover (P/N 529 035 989).

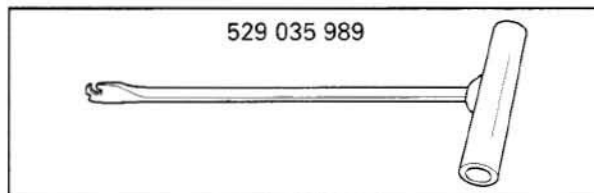



**Section 03 ENGINE**  
**Subsection 06 (EXHAUST SYSTEM)**

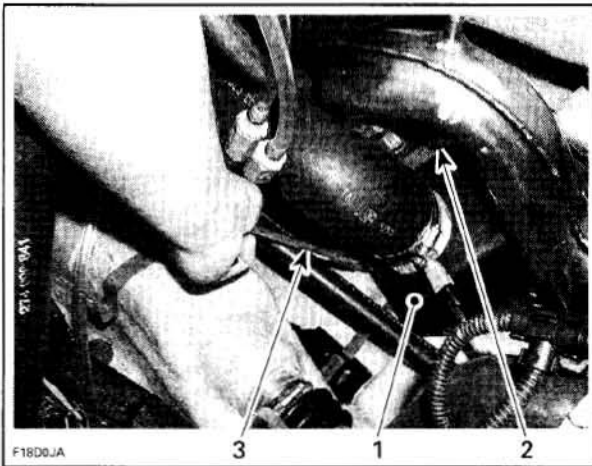

1. Muffer
2. Strap
3. Spring installer/remover

Slowly unscrew exhaust clamp no. 6 and remove it.

**NOTE:** Unscrewing the nut too fast generates heat that will make it harder to unscrew.

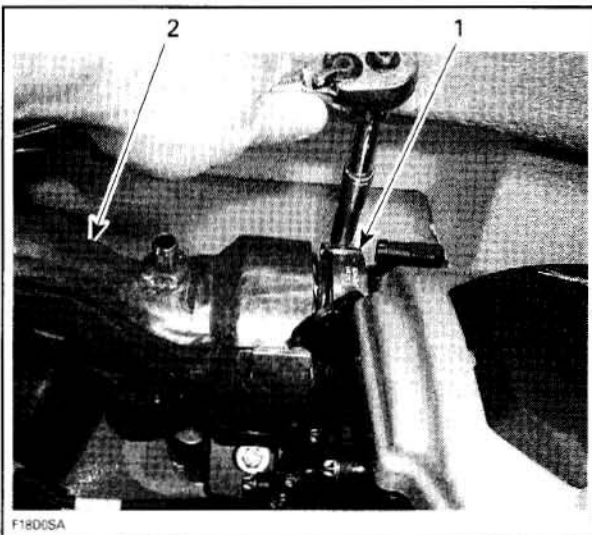

1. Exhaust clamp
2. Exhaust pipe

Move muffer no. 4 backward enough to allow the exhaust pipe to be pulled out.

### Inspection

Inspect exhaust pipe condition paying attention for cracks or other damage. Check joints, coupling areas, heat shield and hoses. Replace any defective part.

### Installation

Installation is essentially the reverse of the removal procedures. However, pay particular attention to the following.

Apply high temperature RTV sealant (P/N 293 800 090) on the welds of the exhaust pipe straight end, while the exhaust pipe is removed from the muffer.



1. High temperature RTV sealant
2. Exhaust pipe straight end

Loosely install clamps no. 2 on muffer hose no. 3.

Insert the exhaust pipe straight end in the muffer hose. Align the exhaust pipe flange to the engine manifold no. 7.

**NOTE:** To achieve a good fit, it could be necessary to push the exhaust pipe straight end further down into the muffer hose over its step. Note distance if pushed over step, then cut hose by obtained measure.

Prealign the exhaust pipe no. 1 by rotating (axially) and moving (longitudinally) the muffer so that the exhaust pipe flange makes perfect contact with the engine manifold.



**Section 03 ENGINE**  
**Subsection 06 (EXHAUST SYSTEM)**

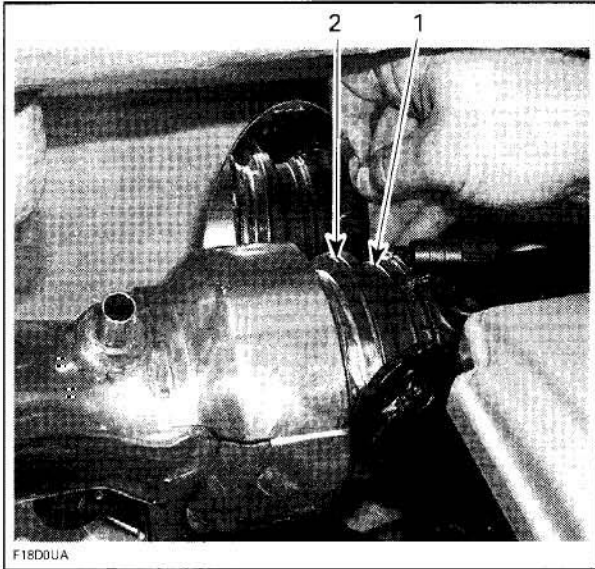

1. Engine manifold  
 2. Exhaust pipe flange

**CAUTION:** Exhaust pipe alignment with the manifold is critical to the bellows life. Any constraint on the flexible joint will result in the bellows failure. Gap between the exhaust pipe flange and the engine manifold should not exceed 0.5 mm (1/64 in).

Position clamps no. 2 to the top portion of the muffler hose. The neighbor clamps must be separated by 4 - 5 mm (5/32 - 3/16 in) and the screws must be at least 25 mm (1 in) apart. Tighten both upper clamps then torque the bottom clamp.

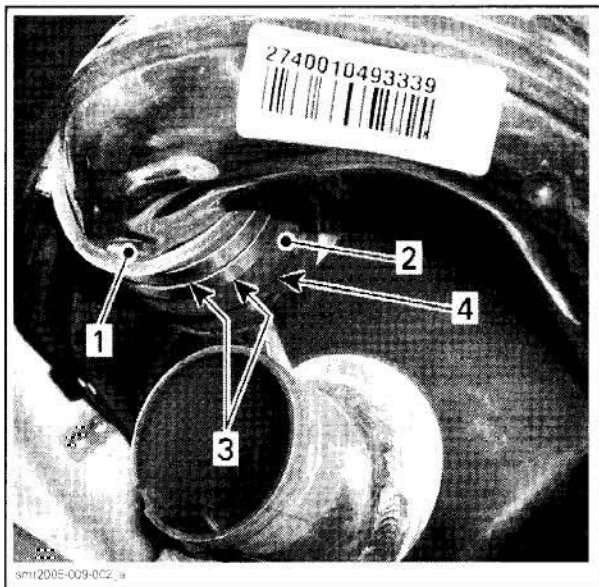

1. Exhaust pipe step  
 2. Muffler hose  
 3. Muffler hose clamp 4 - 5 mm (5/32 - 3/16 in) apart  
 4. Bottom clamp

Finalize alignment by rotating (axially) and moving (longitudinally) the muffler so that the exhaust pipe flange makes perfect contact with the engine manifold. A maximum gap of 0.5 mm (1/64 in) is allowed.

Torque the exhaust clamp no. 6 to 11 N•m (97 lbf•in) while firmly maintaining the exhaust pipe in the proper position.

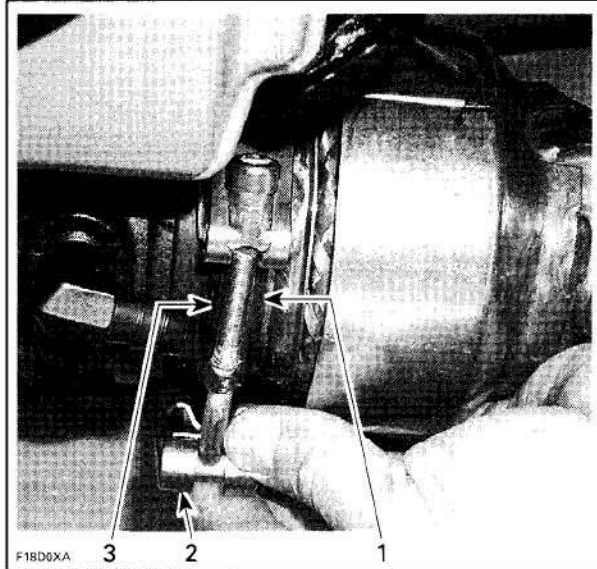

1. Exhaust pipe flange  
 2. Exhaust clamp  
 3. Engine manifold

Apply a soapy solution on inner side of muffler strap no. 5 to prevent muffler rotation at strap installation.

Reinstall muffler strap using the spring installer/remover (P/N 529 035 989). Care must be taken not to induce any rotation of the muffler.

Tighten the bottom clamp of the inlet hose no. 8. Care must be taken not to induce strain on hose to avoid muffler movement.

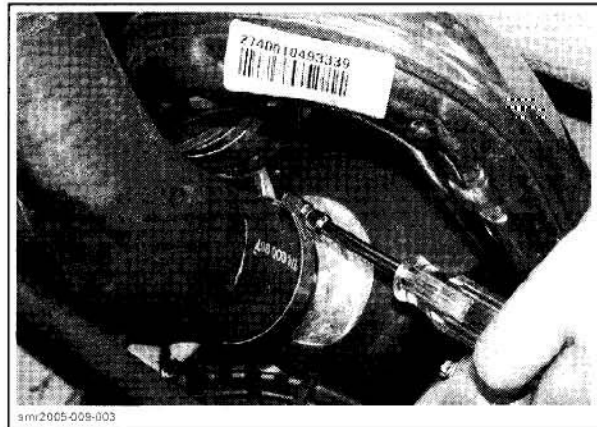

smr2005-008-003



Reconnect cooling hoses to the exhaust pipe and torque clamps to 8 N•m (71 lbf•in).

After installation, ensure there is no water or exhaust gas leak when engine is running. Test run the engine while supplying water to the flushing connector.

**CAUTION:** Never run engine without supplying water to the exhaust cooling system when watercraft is out of water.

## EXHAUST MANIFOLD

### Removal

Disconnect the cooling hoses from the exhaust pipe no. 1.

Remove the exhaust clamp no. 6 and detach the muffler from its support. Move the muffler no. 4 rearwards to separate the exhaust pipe from the manifold. See above in *EXHAUST PIPE*.

Disconnect the cooling system supply hose underneath the front part of the exhaust manifold no. 7.

**NOTE:** On inter-cooled engines, the hose comes from the intercooler.

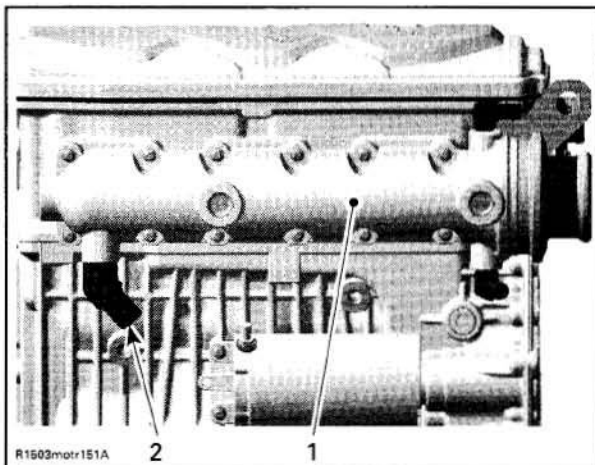

1. Exhaust manifold  
2. Cooling system supply hose location

Unscrew the exhaust manifold beginning with the bottom screws. This will help holding the manifold while you remove the screws.

Remove the manifold and move it out toward the front of the watercraft to withdraw.

**NOTE:** On RXP models, move the manifold rearwards to remove it from vehicle.

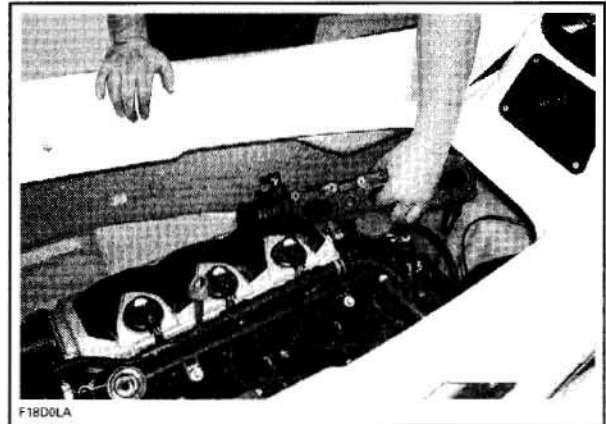

TYPICAL

### Inspection

Inspect exhaust manifold condition paying attention for cracks or other damage. Check contact surfaces and hose. Replace any defective part.

Inspect plane surfaces for warpage. Small deformation can be corrected by grinding surface with a fine sand paper. Install sand paper on a surface plate and rub part against oiled sand paper.

Clean all metal components in a solvent.

### Installation

Installation is essentially the reverse of removal procedures. However, pay particular attention to the following.

**NOTE:** There is no gasket between cylinder block and exhaust manifold.

Apply Loctite 518 (P/N 293 800 038) on threads of screws.

To help holding the manifold while installing screws, first insert the exhaust manifold into the exhaust pipe no. 1 then, install the upper front screw. Continue with the remaining screws.

Torque screws to 10 N•m (89 lbf•in) as per following illustrated sequence. Repeat the procedure, torquing screws again to 10 N•m (89 lbf•in).



## Section 03 ENGINE

### Subsection 06 (EXHAUST SYSTEM)

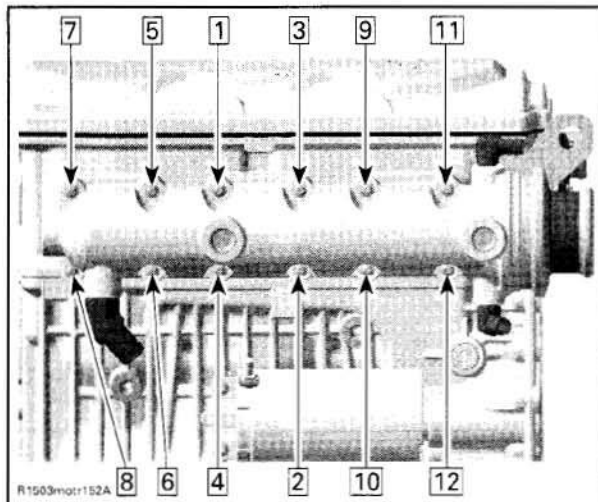

After installation, ensure there is no coolant or exhaust gas leak when the engine is running. Test run the engine while supplying water to the flushing connector.

**CAUTION:** Never run engine without supplying water to the exhaust cooling system when watercraft is out of water.

## MUFFLER

### Removal

Remove the exhaust pipe no. 1. See above.  
Disconnect the temperature sensor connector.  
Disconnect the inlet hose no. 8 then pull muffler no. 4 out of vehicle.

### Inspection

Inspect parts condition paying attention for cracks or other damage. Check hoses. Replace any defective part.

### Installation

Installation is the reverse of the removal procedures.

After installation, ensure there is no coolant or exhaust gas leak when the engine is running. Test run the engine while supplying water to the flushing connector.

**CAUTION:** Never run engine without supplying water to the exhaust cooling system when watercraft is out of water.

## RESONATOR

### Removal

#### **RXP Models**

Remove supercharger inlet hose.  
Disconnect speed sensor connector.  
Remove VTS. Refer to *VARIABLE TRIM SYSTEM*.

#### **All Models**

Disconnect inlet hose no. 8.  
Remove dart or screw no. 9 retaining resonator no. 11.  
Disconnect outlet hose no. 10 from resonator.

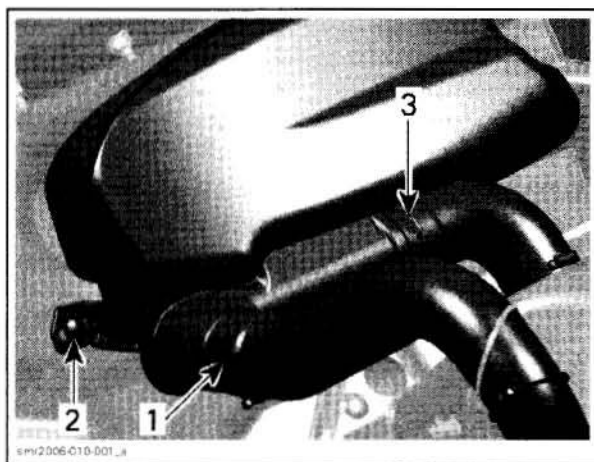

#### **VEHICLES WITH A DART**

1. Inlet hose
2. Dart
3. Outlet hose

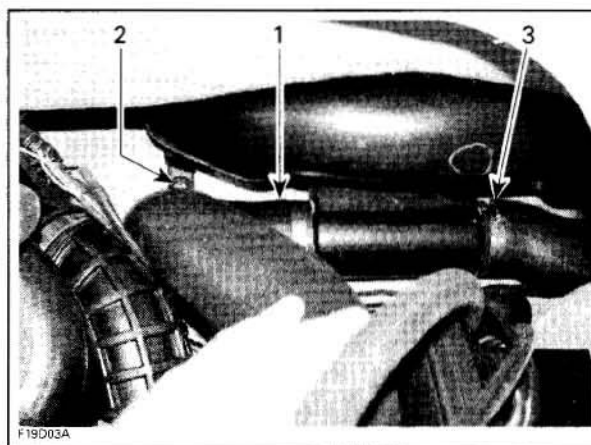

#### **VEHICLES WITH A SCREW**

1. Inlet hose
2. Retaining screw
3. Outlet hose

Carefully pull out the resonator no. 11.

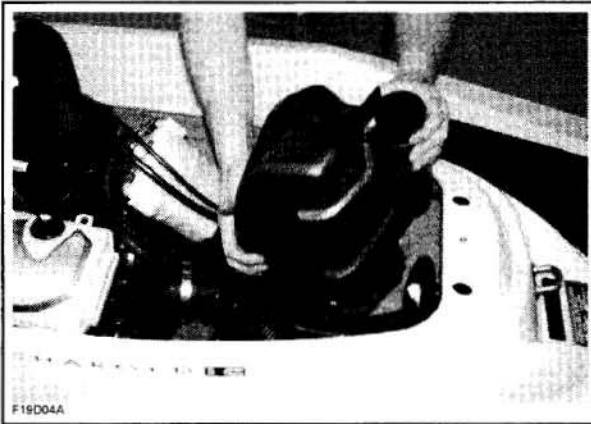

### Inspection

Inspect parts condition paying attention for deformation, cracks or other damage. Check hoses. Replace any defective part.

### Installation

Installation is the reverse of the removal procedures.

For resonator installation, remove outlet hose no. 10 from exhaust outlet no. 12.

Install outlet hose on resonator.

Install resonator in position while inserting outlet hose no. 10 on exhaust outlet.

After installation, ensure there is no coolant or exhaust gas leak when the engine is running. Test run the engine while supplying water to the flushing connector.

**CAUTION:** Never run engine without supplying water to the exhaust cooling system when watercraft is out of water.

## EXHAUST OUTLET

### Removal

Remove resonator retaining dart or screw no. 9. Move resonator forward and disconnect outlet hose no. 10 from exhaust outlet no. 12.

Remove the jet pump as an assembly from pump support. Refer to *PROPULSION SYSTEM*.

From outside of hull, unscrew nut using a suitable tool.

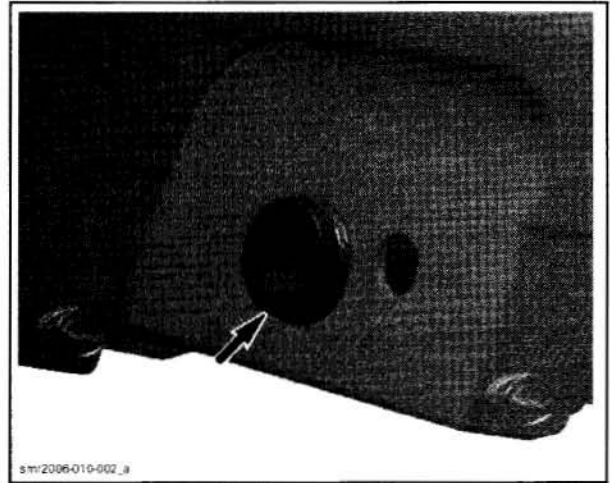

From inside the bilge, remove exhaust outlet.

### Inspection

Inspect parts condition paying attention for cracks or other damage. Check hose. Replace any defective part.

### Installation

Installation is essentially the reverse of the removal procedures. However, pay particular attention to the following.

Apply Loctite silicone sealant (clear) (P/N 293 800 086) on the gasket no. 14 to seal the bilge.

Test the bilge for water leaks.

# PTO HOUSING AND MAGNETO

## SERVICE TOOLS

<b>Description</b>	<b>Part Number</b>	<b>Page</b>
fitting .....	293 710 037 .....	83
impeller remover/installer .....	529 035 820 .....	86
syphon pump.....	529 035 880 .....	83

## SERVICE PRODUCTS

<b>Description</b>	<b>Part Number</b>	<b>Page</b>
Isoflex Topas NB52 grease .....	293 550 021 .....	90
Loctite 243.....	293 800 060 .....	83, 86, 88–89
Loctite 648.....	413 711 400 .....	91
Loctite anti-seize.....	293 800 070 .....	87
pulley flange cleaner.....	413 711 809 .....	83–84, 86



# Section 03 ENGINE

## Subsection 07 (PTO HOUSING AND MAGNETO)

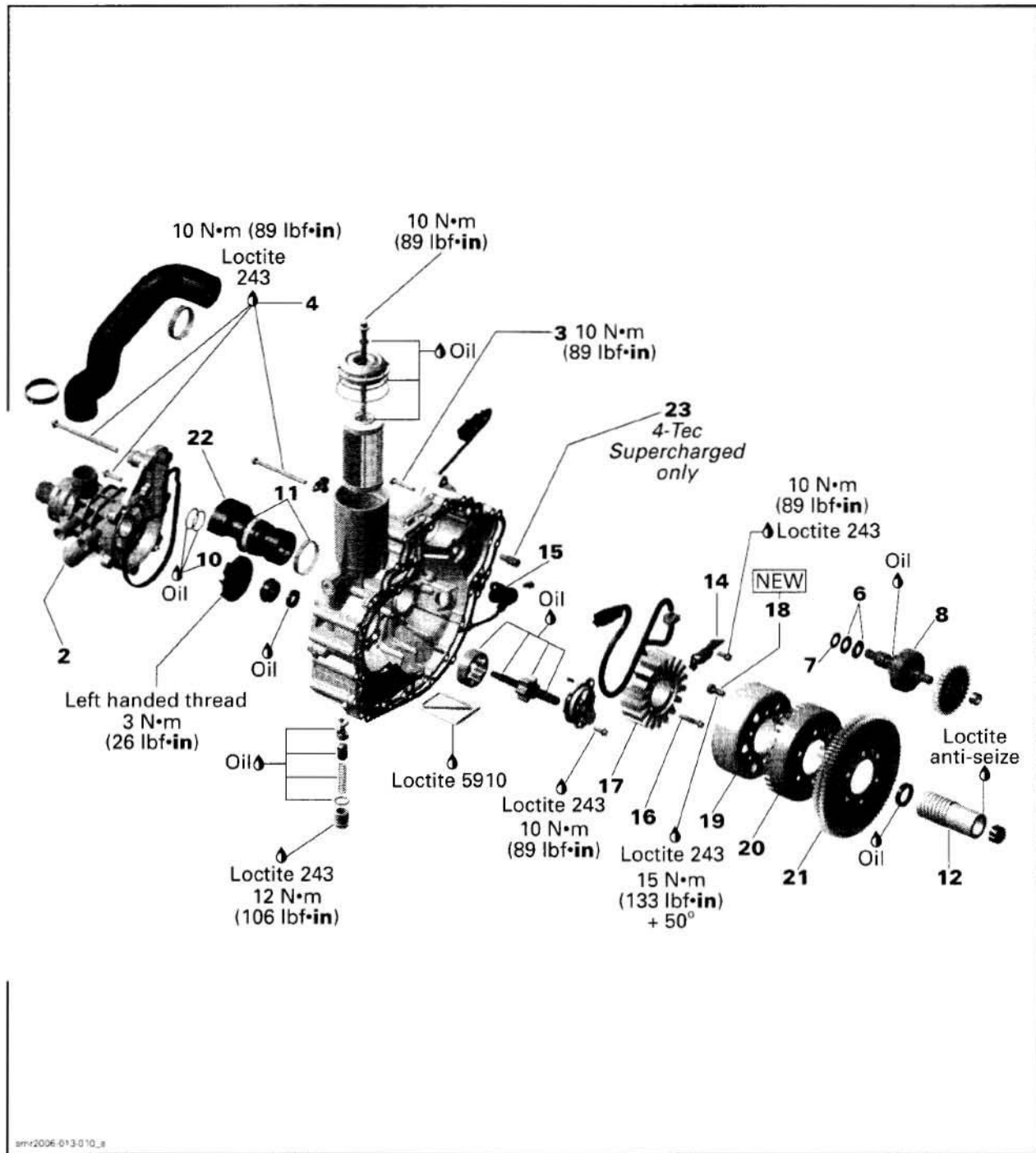

smr2006-013-010\_3

## GENERAL

Always perform the electric tests before removing or installing any components.

During assembly, use torque values and service products as in the exploded view.

Clean threads before applying a threadlocker. Refer to *SELF-LOCKING FASTENERS* and *LOCTITE APPLICATION* at the beginning of this manual for complete procedure.

### WARNING

Torque wrench tightening specifications must strictly adhered to.

Locking devices (e.g.: locking tabs, elastic stop nuts, self-locking fasteners, cotter pins, etc.) must be installed or replaced with new ones where specified. If the efficiency of a locking device is impaired, it must be renewed.

## PROCEDURES

### PTO HOUSING

#### Removal

Drain engine oil. Refer to *LUBRICATION SYSTEM*.

Drain oil from PTO housing using one of the following procedures:

#### Procedure for Removing Oil in PTO Housing Through the Scavenge Oil Pump Cover

- Remove the scavenge oil pump cover drain plug.

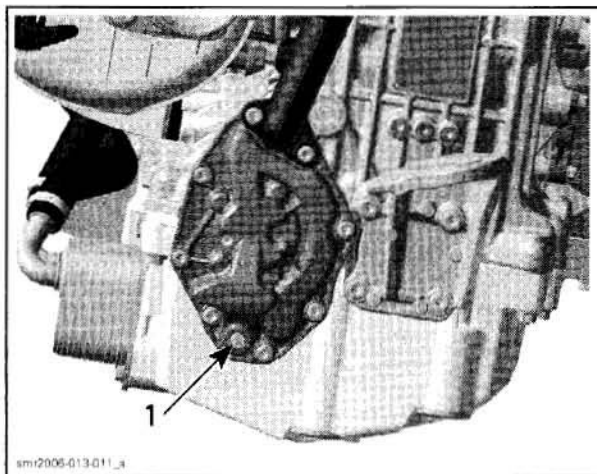

*TYPICAL*  
1. Scavenge oil pump cover drain plug

- Install tool fitting (P/N 293 710 037).

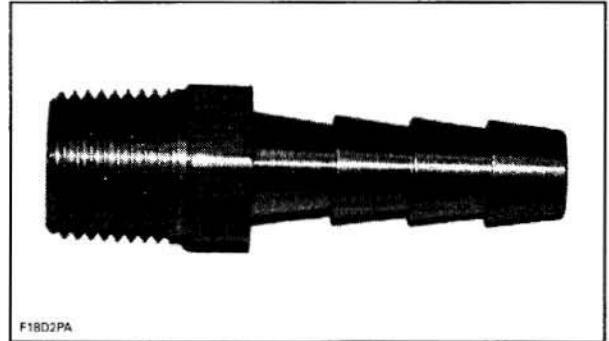

*TYPICAL*

- Connect the syphon pump (P/N 529 035 880) to the fitting.

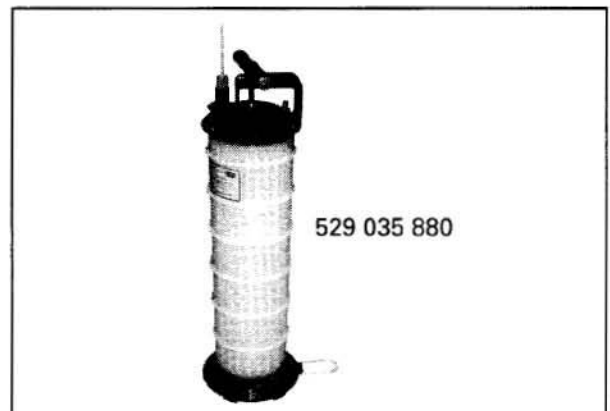

- The front of the engine must be tilted down approximately 15 degrees to facilitate the removal of the oil. Raise the rear of the watercraft accordingly. Siphon the oil from the fitting.
- When done, remove the syphon pump and the fitting. Apply Loctite 243 (P/N 293 800 060) and reinstall the drain plug.

**NOTE:** If spillage occurs, clean immediately with the pulley flange cleaner (P/N 413 711 809) to prevent oil stains.

#### Procedure for Removing Oil in the PTO Housing through the Timing Chain Area

As an alternate method, the oil located in the PTO housing can be syphoned through the timing chain area.

- Remove the valve cover. Refer to *CYLINDER HEAD* section.
- Using the syphon pump (P/N 529 035 880), insert the tube in the lower area of the timing chain. Siphon the oil.



## Section 03 ENGINE

### Subsection 07 (PTO HOUSING AND MAGNETO)

#### PTO Housing Removal

Place rags under PTO housing to prevent spillage. Up to 250 mL (8 oz) of oil could flow out when removing PTO housing. If spillage occurs, clean immediately with the pulley flange cleaner (P/N 413 711 809) to prevent oil stains.

Disconnect CPS and magneto from wiring harness.

#### **⚠ WARNING**

Always disconnect battery or starter cables exactly in the specified order, **BLACK** negative cable first. Disconnect electrical connections prior to disconnecting fuel lines.

Slightly lift rear part of engine and safely block in this position. Remove rear LH side engine support no. 1.

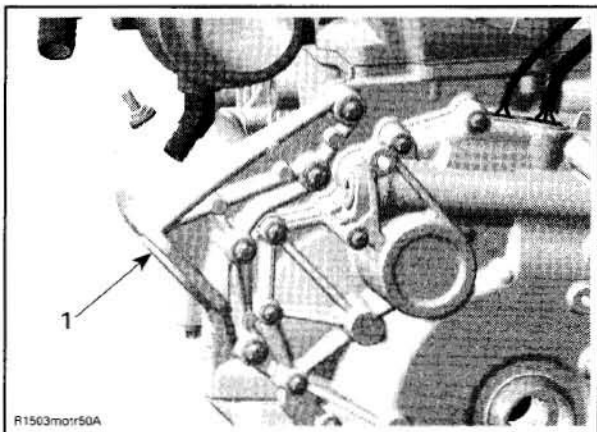

TYPICAL  
1. Engine support

Remove:

- thru-hull fitting boot

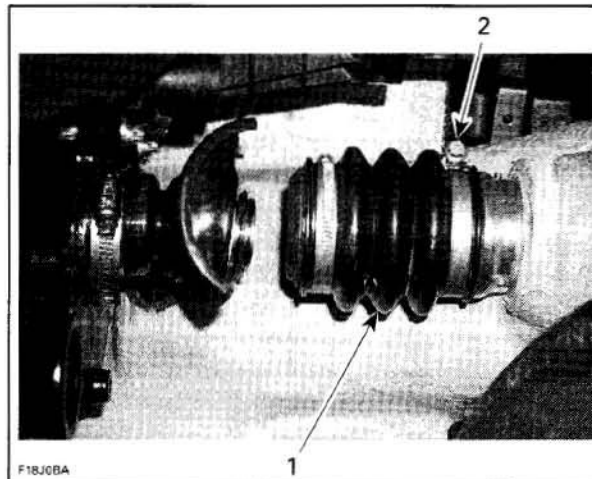

1. Thru-hull fitting boot  
2. Remove this collar

- water pump housing no. 2 (refer to *COOLING SYSTEM*)
- unplug CPS connector
- screws no. 3 and no. 4

**NOTE:** Carefully separate the PTO housing from the engine using two flat screwdrivers prying equally at the same time. Proceed slowly so that starter gear disc springs no. 6 and washer no. 7 do not fall down.

- PTO housing no. 5

**CAUTION:** Ensure to use prying lugs to separate PTO housing to prevent damaging contact surface.

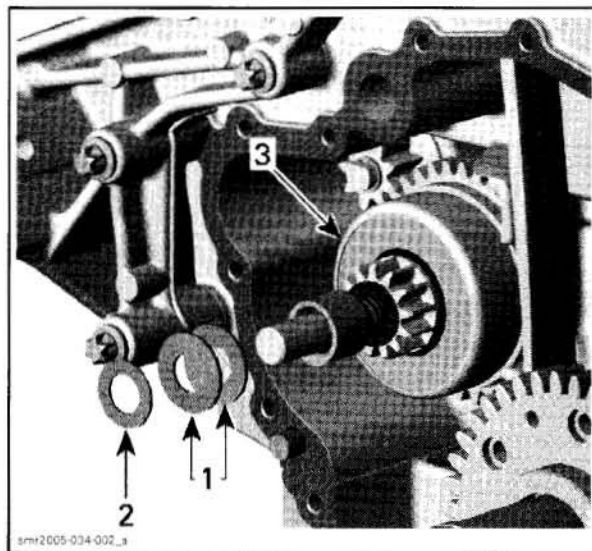

1. Disc springs  
2. Washer  
3. Starter drive gear

- gasket no. 9.



**Inspection**

Check PTO housing for cracks or other damages. Replace if necessary.

**Installation**

**NOTE:** Clean all metal component in a non-ferrous metal cleaner.

**⚠ WARNING**

Wear safety glasses and work in a well ventilated area when working with strong chemical products. Also wear suitable non-absorbent gloves to protect your hands.

For installation, reverse the removal procedure. However, pay attention to the following.

**NOTE:** Turn the oil/water pump shaft in the right position to fit into the balance shaft.

Position the disc springs **no. 6** and washer **no. 7** as per the following illustration.

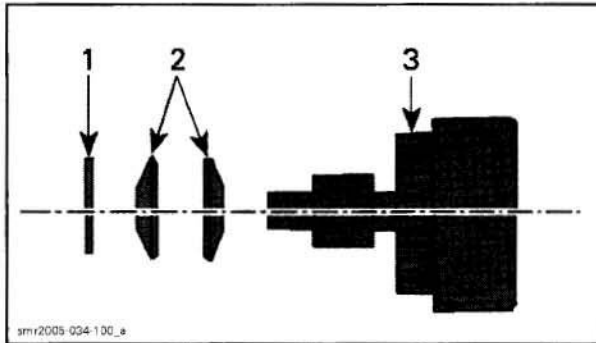

**TYPICAL**  
1. Washer  
2. Disc spring  
3. Starter drive ass'y

**NOTE:** When installing a new starter drive ass'y, oil the shaft and threads of the gear with engine oil.

**CAUTION:** Ensure the starter drive gear shaft is well engaged in its bore.

Gently install PTO housing.

**CAUTION:** While installing housing, pay particular attention that gasket does not get pinched or slide out of its contact surface in the area shown in the following illustration. Never force to install cover. If there is a strong resistance, remove housing and check oil/water pump alignment and starter gear alignment.

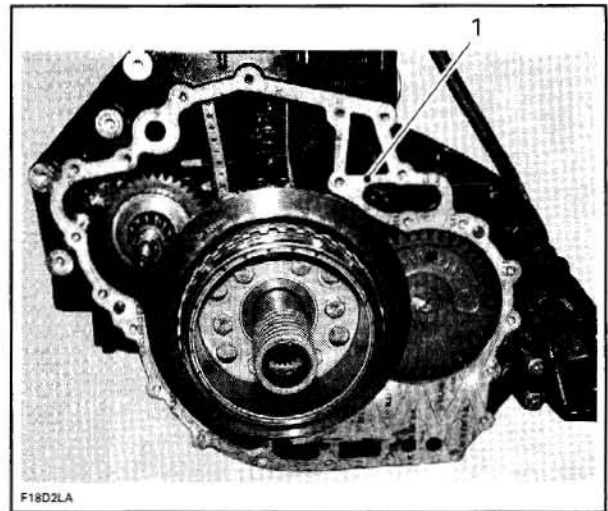

1. Pay attention that gasket remains properly positioned on this surface

Refer to the following illustration for proper installation of screws.

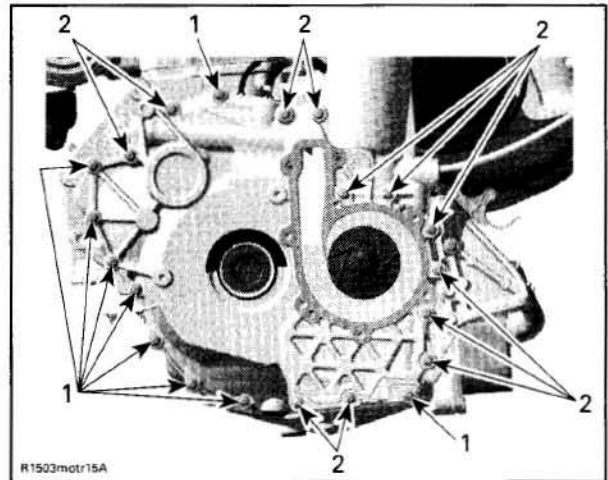

**TYPICAL**  
1. Screws M6 x 35  
2. Screws M6 x 85

Tightening sequence for screws on PTO housing is as per following illustration.

## Section 03 ENGINE

### Subsection 07 (PTO HOUSING AND MAGNETO)

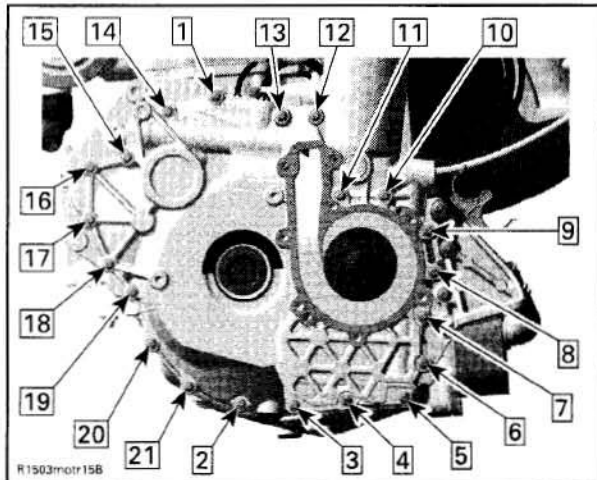

Reinstall LH engine support. Apply Loctite 243 (P/N 293 800 060) on screw threads then torque to 24 N•m (17 lbf•ft).

Remove block under engine.

Refill engine with oil and cooling system with coolant. Refer to *LUBRICATION SYSTEM* and *COOLING SYSTEM* sections.

## PTO SEAL

### Inspection

Check the PTO seal no. 22 and O-rings no. 10 on the PTO housing. If brittle, hard or damaged, or if you see a sign of oil leakage, replace it.

### Removal

Place rags under PTO housing to prevent spillage. If spillage occurs, clean immediately with the pulley flange cleaner (P/N 413 711 809) to prevent oil stains.

Remove:

- Oetiker clamp no. 11 located close to the PTO housing
- PTO seal no. 22.

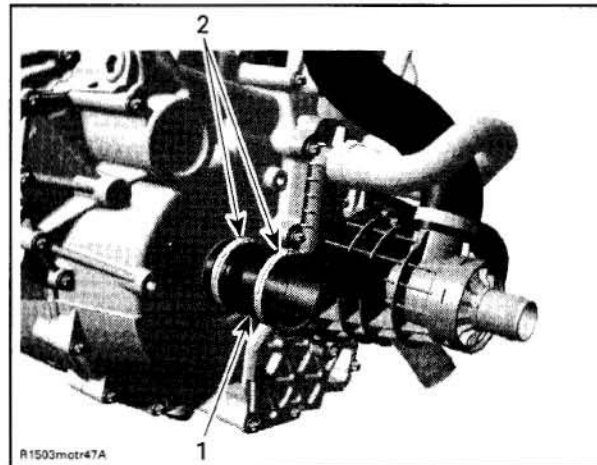

TYPICAL  
1. Oetiker clamps  
2. PTO seal

## Installation

Reinstall removed parts in the reverse order.

**CAUTION:** When installing PTO seal on super-charged engines, make sure to position the Oetiker clamps as shown in the picture.

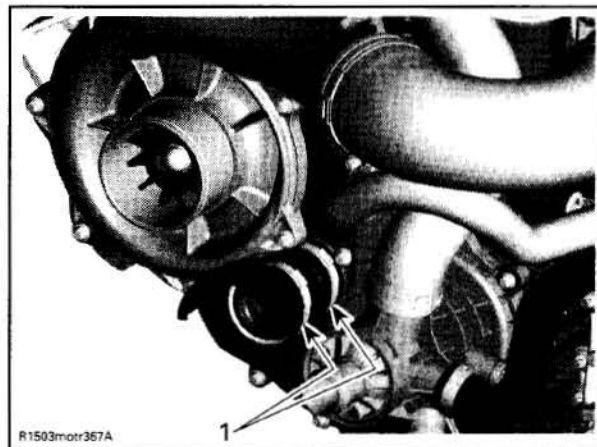

1. Oetiker clamps

## COUPLING

### Removal

Lock crankshaft. Refer to *CYLINDER BLOCK* section for procedure.

Remove:

- PTO seal as described above
- coupling no. 12 using impeller remover/installer (P/N 529 035 820).

**NOTE:** PTO coupling has right hand thread.



**Section 03 ENGINE**  
Subsection 07 (PTO HOUSING AND MAGNETO)

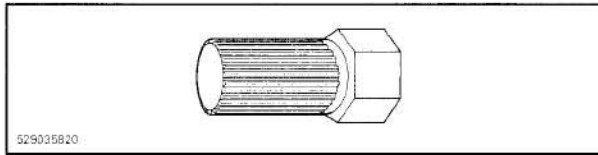

**CAUTION:** Apply some oil on the tool to protect the seal located in the PTO coupling.

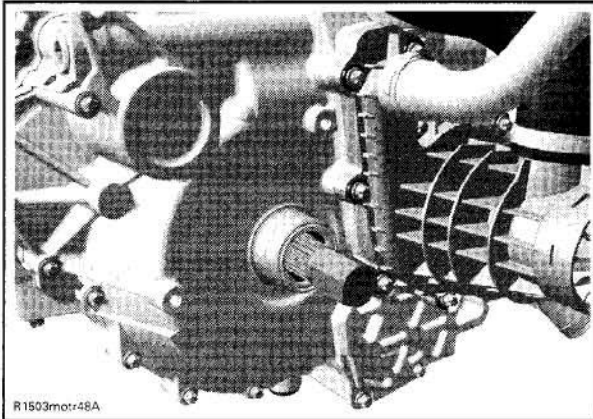

TYPICAL

### Inspection

Check if seal no. 13 is brittle, cracked or hard. Check coupling for worn splines. If damaged, replace faulty part.

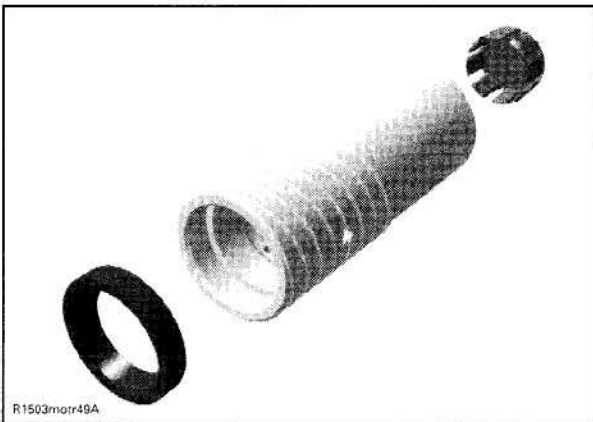

### Installation

For installation, reverse the removal procedure. However, pay attention to the following.  
Torque PTO coupling to 250 N•m (184 lbf•ft). Apply Loctite anti-seize (P/N 293 800 070) on threads.

## STATOR

### Removal

- Remove:
- PTO housing (see procedure in this section)

- CPS connector

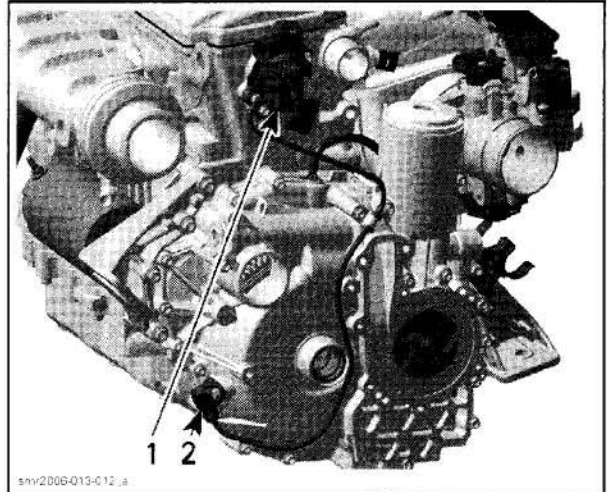

1. CPS connector
2. CPS

- holding plate no. 14

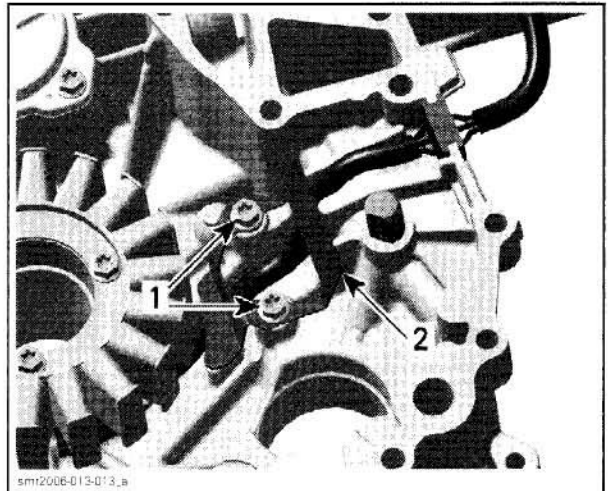

- TYPICAL
1. screws
  2. Holding plate

- screws no. 16
- stator no. 17.



## Section 03 ENGINE

### Subsection 07 (PTO HOUSING AND MAGNETO)

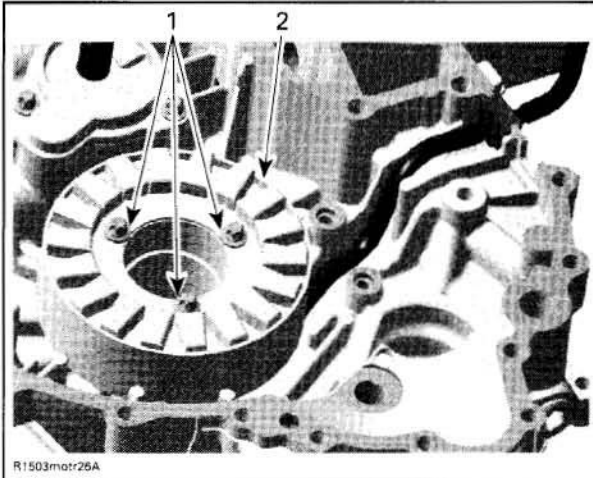

**TYPICAL**  
1. Stator screws  
2. Stator

#### Installation

For installation, reverse the removal procedure. However, pay attention to the following.

**NOTE:** There is only one position for the stator (notch in the magneto housing cover).

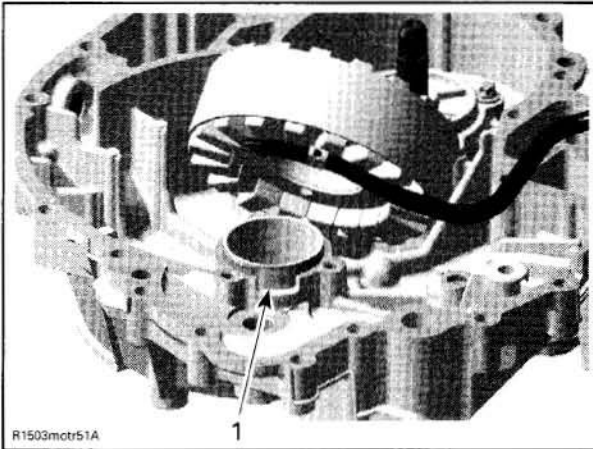

**TYPICAL**  
1. Notch for stator

Place the rubber grommet in the proper notch at the PTO housing.

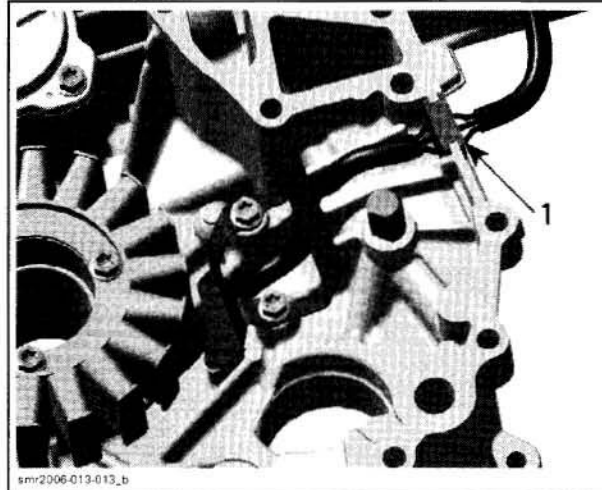

**TYPICAL**  
1. Grommet on stator cable

Apply Loctite 243 (P/N 293 800 060) on threads. Torque stator and CPS screws to 10 N•m (88 lbf•in).

#### ROTOR AND TRIGGER WHEEL

##### Removal

Lock crankshaft. Refer to *CYLINDER BLOCK* section for procedure.

Remove:

- PTO housing
- hexagonal screws no. 18 retaining rotor.

Withdraw rotor no. 19 with trigger wheel no. 20.

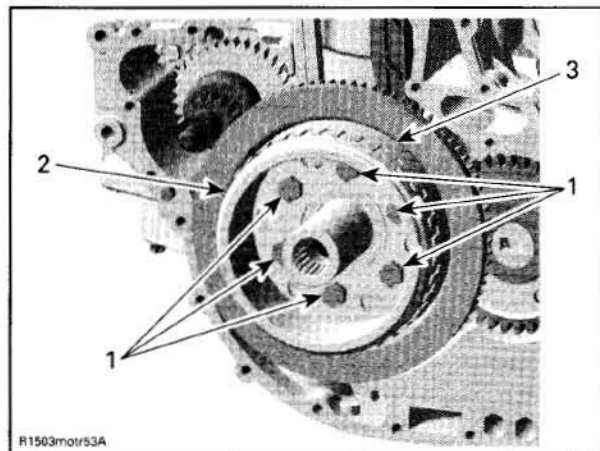

**TYPICAL**  
1. Hexagonal screws  
2. Rotor  
3. Trigger wheel

##### Inspection

Check rotor, bent teeth and trigger wheel condition. If damaged, replace faulty part.

## Section 03 ENGINE

### Subsection 07 (PTO HOUSING AND MAGNETO)

To check the trigger wheel for bent teeth, proceed as follows.

Install a dial indicator on crankcase casting. Position the gauge on a tooth and set it to zero (0). Rotate flywheel and check needle movement. The maximum allowed difference between teeth is 0.15 mm (.006 in). Otherwise, straighten the tooth or replace the trigger wheel.

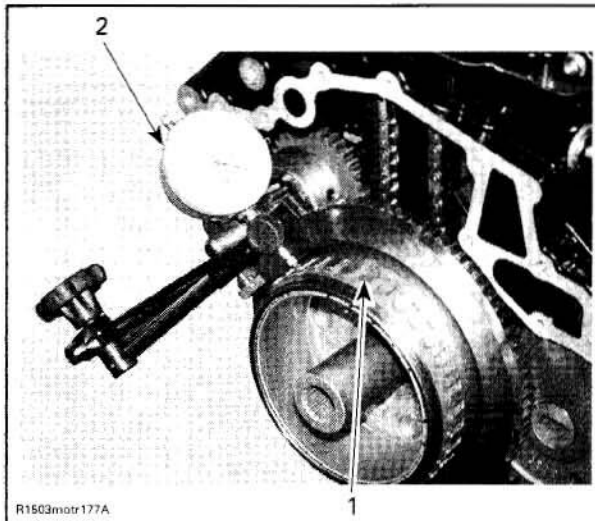

1. Trigger wheel
2. Dial indicator

Properly reinstall cover.

### Installation

For installation, reverse the removal procedure. However, pay attention to the following.

Trigger wheel position has to be located with the location pin on the crankshaft gear.

**NOTE:** Do not reuse rotor screws no. 18, replace all 6 screws. These are stretch screws. Not following this procedure could lead to engine failure.

Apply Loctite 243 (P/N 293 800 060) on threads. Torque rotor screws to 15 N•m (133 lbf•in) in a crisscross sequence.

**CAUTION:** Always use new OEM screws.

Finish tightening screws with an additional 50° rotation with a torque angle gauge.

### RING GEAR

#### Removal

Lock crankshaft. Refer to *CYLINDER BLOCK* section for procedure.

Remove:

- PTO housing cover

- hexagonal screws no. 18.

Withdraw rotor no. 19, trigger wheel no. 20 and ring gear no. 21.

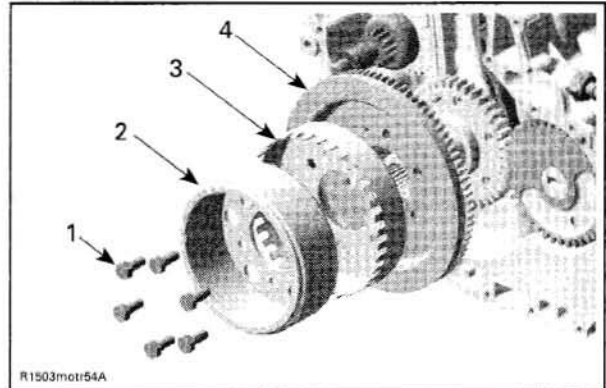

#### TYPICAL

1. Hexagonal screws
2. Rotor
3. Encoder wheel
4. Ring gear

### Inspection

Check ring gear condition, especially teeth condition. If damaged, replace faulty part.

### Installation

For installation, reverse the removal procedure. However, pay attention to the following.

Ring gear and trigger wheel position has to be located with the location pin on the crankshaft gear.

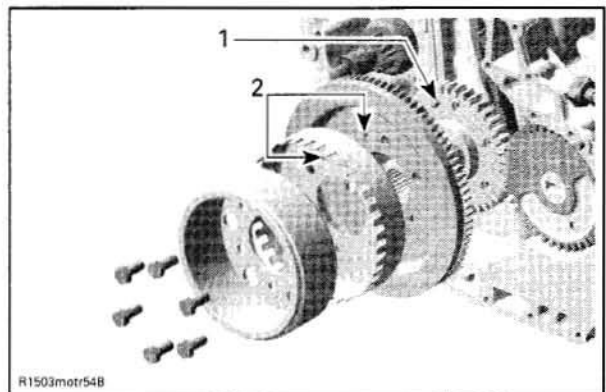

#### TYPICAL

1. Location pin
2. Location pin holes

Apply Loctite 243 (P/N 293 800 060) on threads. Torque rotor screws to 24 N•m (17 lbf•ft).



## Section 03 ENGINE

### Subsection 07 (PTO HOUSING AND MAGNETO)

## STARTER DRIVE

### Removal

Remove:

- PTO housing and ring gear as described above
- starter drive ass'y no. 8.

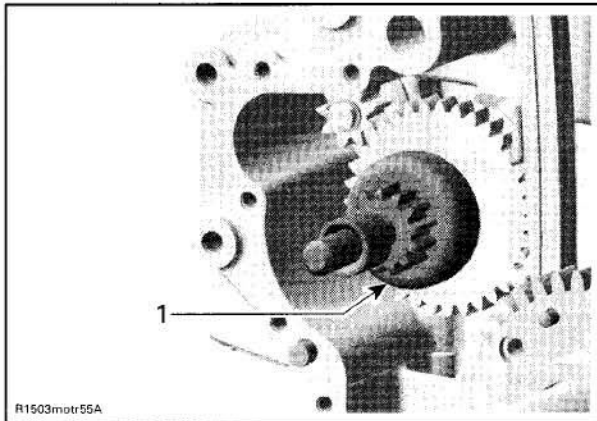

TYPICAL

1. Starter drive ass'y

**CAUTION:** Be careful not to lose the distance washer, disc springs no. 6 and washer no. 7 located on the starter drive shaft.

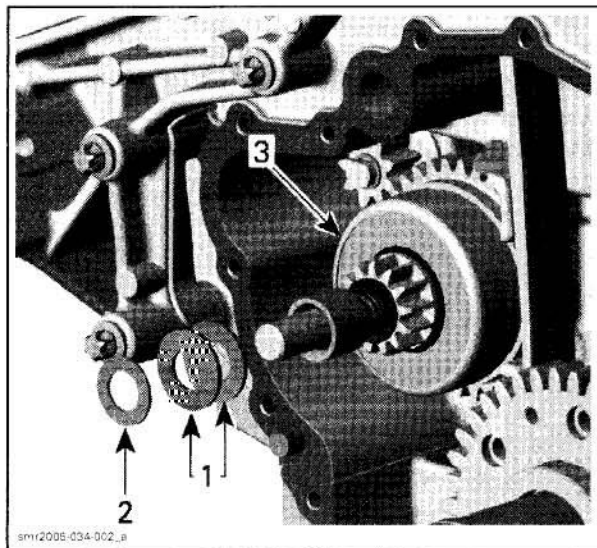

TYPICAL

1. Disc springs
2. Washer
3. Starter drive gear

### Inspection

Check condition of the teeth, shaft, etc. and if the sprag clutch operates well. If damaged, replace faulty part.

### Installation

For installation, reverse the removal procedure. However, pay attention to the following.

**NOTE:** When installing a new starter drive ass'y, oil the shaft and threads of the gear with engine oil.

Apply some Isoflex Topas NB52 grease (P/N 293 550 021) on the starter drive bearing located in the cylinder block and on the starter drive support in the PTO housing cover.

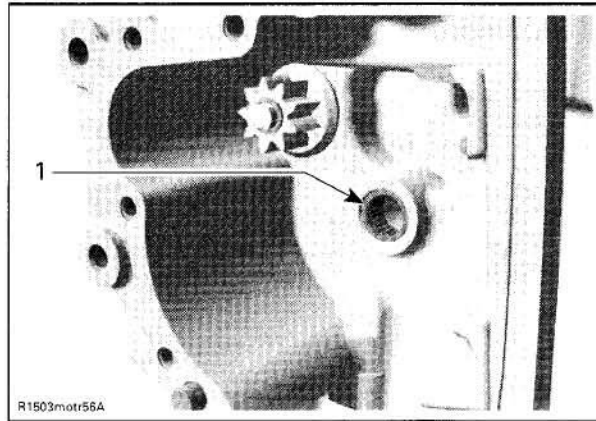

TYPICAL

1. Starter drive bearing

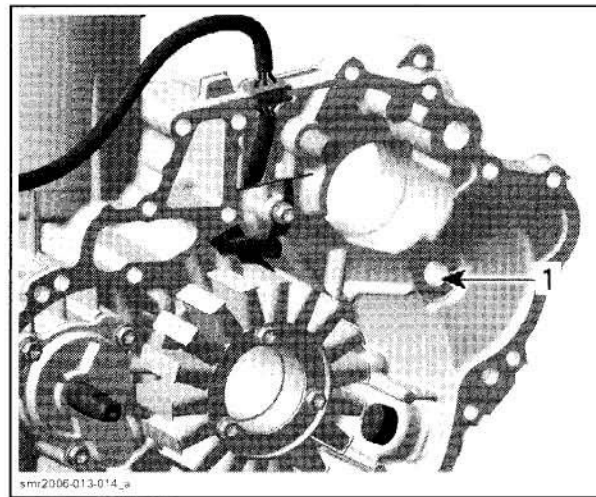

TYPICAL

1. Starter drive support

**CAUTION:** Be sure not to forget the distance washer, disc springs and washer on the starter drive shaft when assembling.



## OIL SPRAY NOZZLE

### *Supercharged Engines Only*

#### Removal

Remove the PTO housing as described above:

- Turn oil spray nozzle no. 23 by using a grip plier to crack the Loctite.

**CAUTION:** Do not try to pull out the oil spray nozzle with a plier. This may damage the force fit in the PTO housing.

- Fix supercharger spray nozzle remover tight on oil spray nozzle.

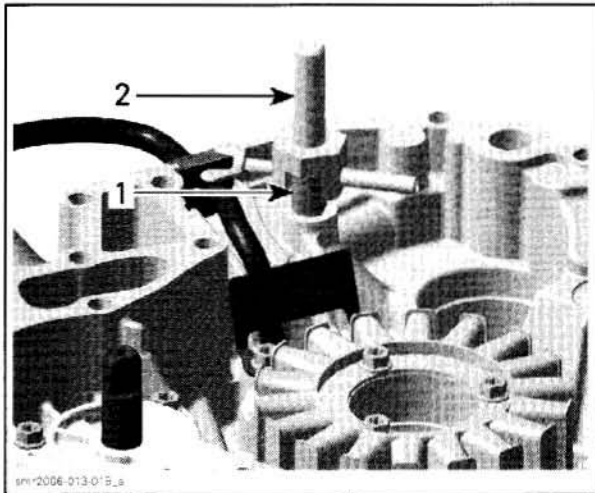

1. Oil spray nozzle
2. Spray nozzle remover

- Remove oil spray nozzle carefully by using a slide hammer puller.

#### Installation

For installation, reverse the removal procedure. However, pay attention to the following.

Apply Loctite 648 (P/N 413 711 400) on oil spray nozzle fitting surface.

**CAUTION:** The oil spray nozzle must be in exact position to supply enough oil to the supercharger. Any other installation will lead to a supercharger damage.

Only use supercharger spray nozzle installer to push in the nozzle no. 23. Use retaining screw hole to ensure the exact position.

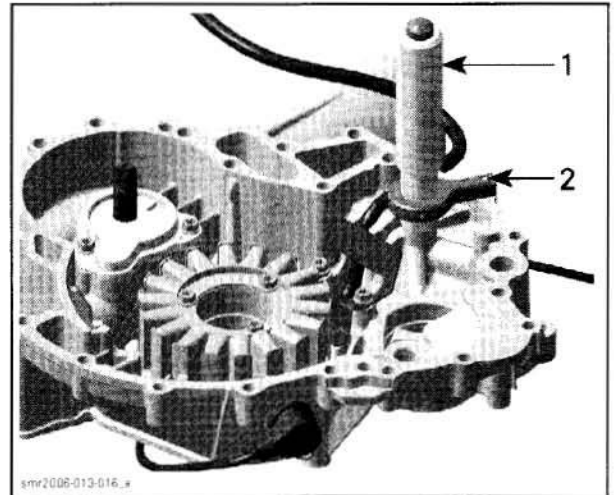

1. Spray nozzle installer
2. Screw hole for positioning

# LUBRICATION SYSTEM

## SERVICE TOOLS

<b>Description</b>	<b>Part Number</b>	<b>Page</b>
hose adaptor .....	529 035 652 .....	98
oil filter cover puller .....	529 036 057 .....	97
oil filter cover separator .....	529 036 038 .....	97
oil pressure gauge .....	529 035 709 .....	98
oil seal guide .....	529 035 822 .....	105
rotary seal pusher .....	529 035 823 .....	105
suction pump .....	529 035 880 .....	97

## SERVICE PRODUCTS

<b>Description</b>	<b>Part Number</b>	<b>Page</b>
Loctite 243 .....	293 800 060 .	101–102, 106, 108, 110–111
pulley flange cleaner .....	413 711 809 .....	97, 100, 106
Super Lube grease .....	293 600 016 .....	98

# Section 03 ENGINE

## Subsection 08 (LUBRICATION SYSTEM)

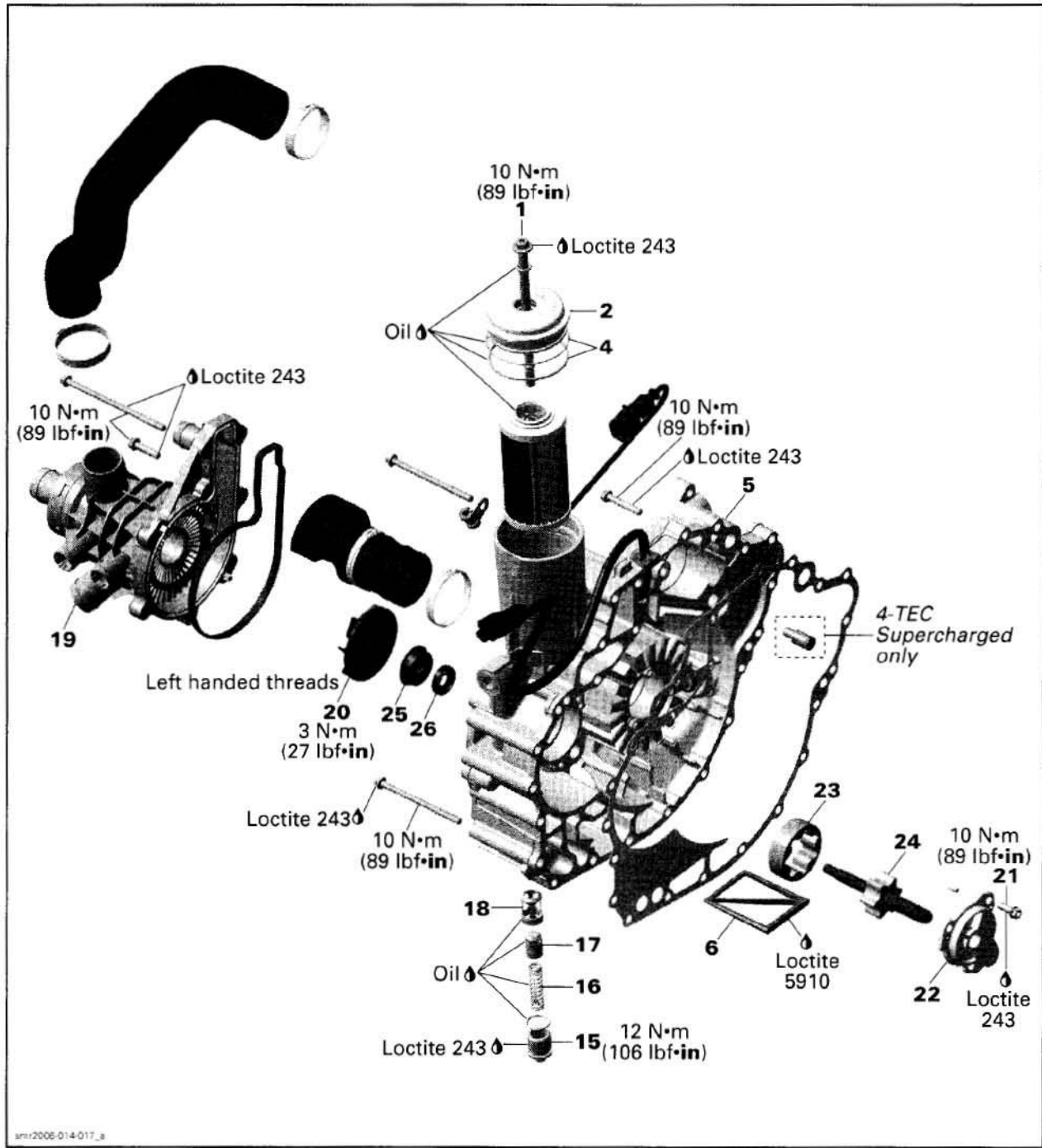



**Section 03 ENGINE**  
**Subsection 08 (LUBRICATION SYSTEM)**

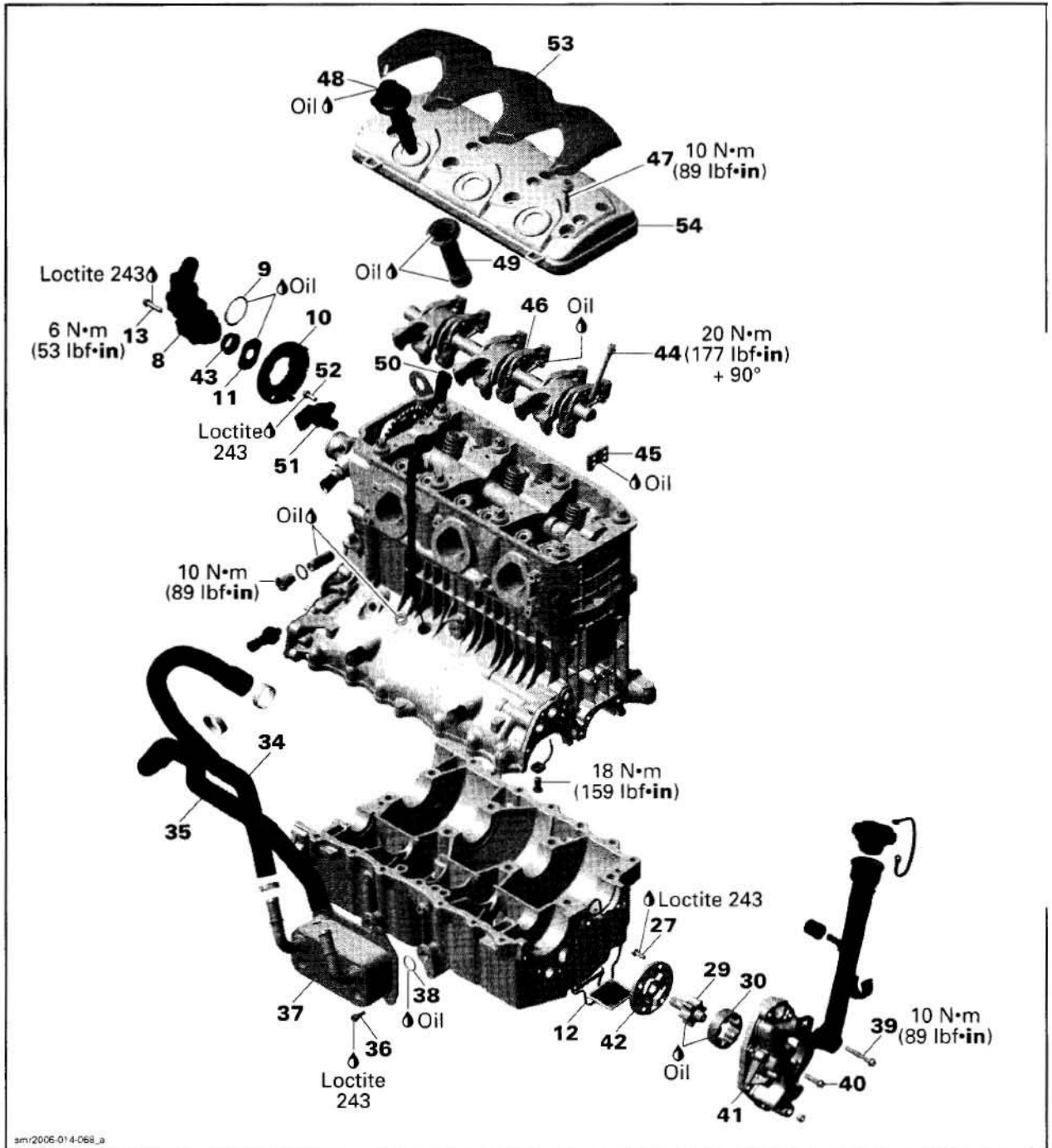

## Section 03 ENGINE

### Subsection 08 (LUBRICATION SYSTEM)

## MAINTENANCE

### OIL LEVEL VERIFICATION

**CAUTION:** Check level frequently and refill if necessary. Do not overfill - it would make the engine smoke and reduce its power. Operating the engine with an improper level may severely damage engine. Wipe off any spillage.

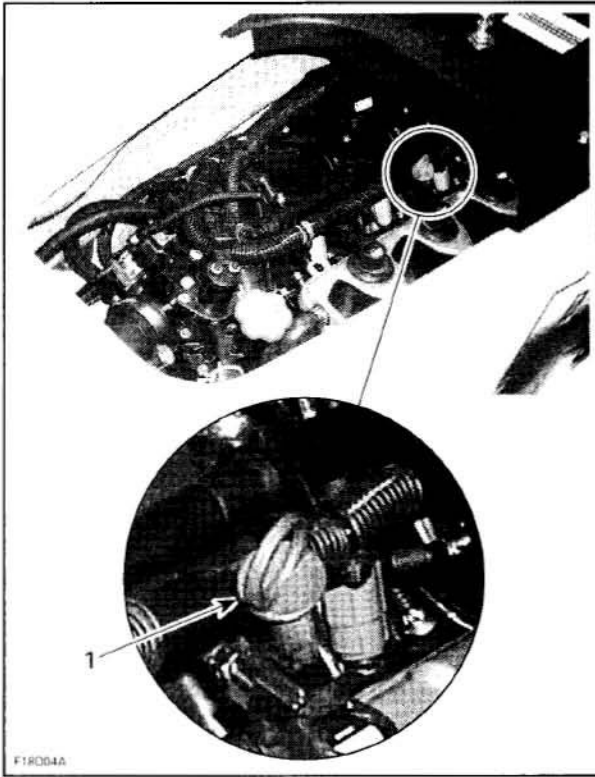

1. Dipstick

Check the oil level as follows:

**NOTE:** It is of the utmost importance to follow this procedure in order to obtain an accurate reading of the engine oil level.

- Watercraft must be level. Check oil level either with watercraft in water or out of water. Engine should be **warm**.

**CAUTION:** Never run engine without supplying water to the exhaust cooling system when watercraft is out of water.

- If out of water, raise trailer tongue and block in position when bumper rail is level. Link a garden hose to the hose adapter. Refer to *STORAGE PROCEDURES* in *MAINTENANCE* section and follow the procedures.

**CAUTION:** Failure to flush exhaust cooling system, when watercraft is out of water, may severely damage engine and/or exhaust system.

- Warm-up engine then let idle for 30 seconds before stopping.
- Stop engine.
- Wait at least 30 seconds then pull dipstick out and wipe clean.

### WARNING

Engine oil may be hot. Certain components in the engine compartment may be very hot. Direct contact may result in skin burn.

**CAUTION:** Never run engine longer than 5 minutes. Drive line seal has no cooling when watercraft is out of water.

- Reinstall dipstick, push in completely.
- Remove dipstick and read oil level. It should be between marks.

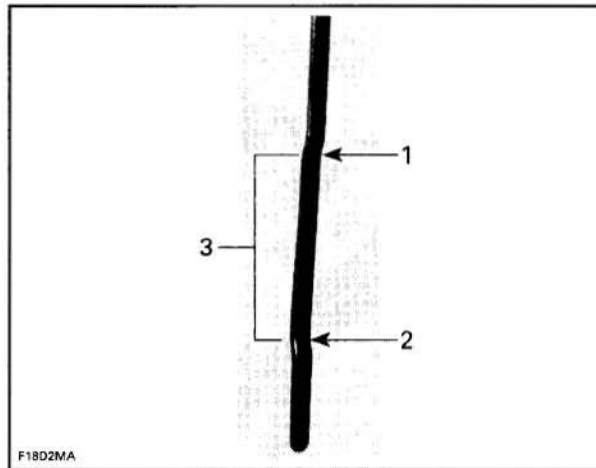

1. Full
2. Add
3. Operating range

- Otherwise, add oil until its level is between marks as required.
- To add oil, unscrew oil cap. Place a funnel into the opening and add the recommended oil to the proper level. Do not overfill.

## OIL CHANGE

Oil and oil filter must be replaced at the same time. Oil change and oil filter replacement should be done with a warm engine.

### Oil Draining

**NOTE:** If water is found in oil (oil will be milky), refer to *SPECIAL PROCEDURES* in *MAINTENANCE* section and follow the procedure to flush it.



## Section 03 ENGINE

### Subsection 08 (LUBRICATION SYSTEM)

Bring engine to its normal operating temperature.

**CAUTION:** Never run engine without supplying water to the exhaust system when watercraft is out of water.

**CAUTION:** Failure to cool exhaust system, when engine is out of water, may severely damage exhaust system.

#### **⚠ WARNING**

Engine oil may be hot. Certain components in the engine compartment may be very hot. Direct contact may result in skin burn.

**CAUTION:** Never run engine longer than 5 minutes. Drive line seal has no cooling when watercraft is out of water.

Run engine for 10 seconds at 4000 RPM and shut it off at this RPM. This will move oil from PTO housing to oil tank to allow maximum oil draining. Remove oil filler cap and dipstick.

Using the suction pump (P/N 529 035 880), siphon oil through dipstick hole.

**CAUTION:** Never crank or start engine when siphon tube is in dipstick hole. Never start engine when there is no oil in engine.

**NOTE:** So that siphon tube is located at the proper height to siphon oil, it is suggested to put some electrical tape on siphon tube at 475 mm (18.7 in) from its end. Then, insert siphon tube until you reach the tape.

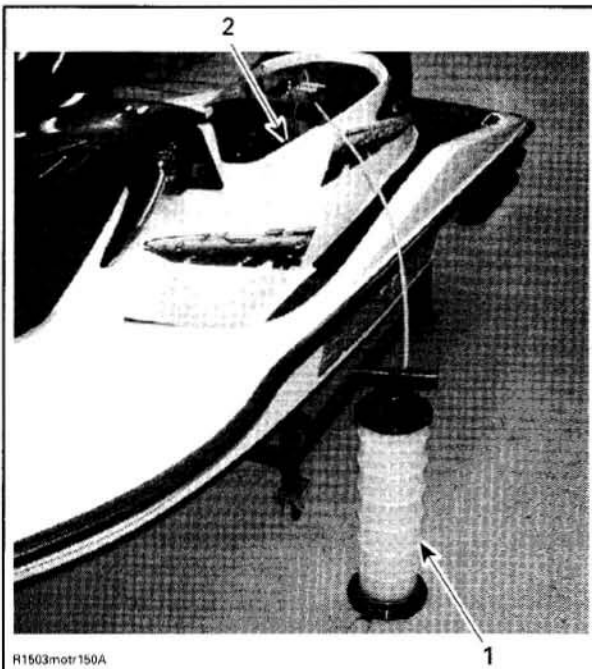

1. Suction pump  
2. Siphon tube in dipstick hole

Pull siphon tube out of dipstick hole then crank engine (do not start) while in engine down mode (fully depress throttle lever and HOLD, then crank engine).

Crank engine for 10 seconds. Siphon oil again. Repeat the crank-siphon cycle 2 - 3 times.

#### Oil Filling

Refill engine with oil meeting the specific requirements of the engine. Refer to *TECHNICAL SPECIFICATIONS*. Reinstall oil filler cap and dipstick.

#### OIL FILTER

##### Removal

Remove:

- oil filter screw
- oil filter cover
- oil filter.

**NOTE:** If the oil filter cover is hard to remove, use the oil filter cover separator (P/N 529 036 038) and the oil filter cover puller (P/N 529 036 057).

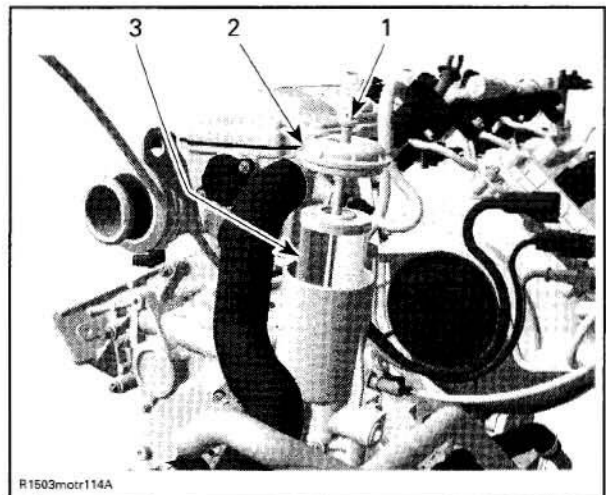

##### TYPICAL

1. Oil filter screw
2. Oil filter cover
3. Oil filter

Place rags in filler area to prevent spillage. If spillage occurs, clean immediately with the pulley flange cleaner (P/N 413 711 809) to prevent stains.

#### **⚠ WARNING**

Wear safety glasses and work in a well ventilated area when working with strong chemical products. Also wear suitable non-absorbent gloves to protect your hands.



## Section 03 ENGINE

### Subsection 08 (LUBRICATION SYSTEM)

#### Inspection

Check oil filter cover O-ring and oil filter screw O-ring, change if necessary.

Check and clean the oil filter inlet and outlet area for dirt and other contaminations.

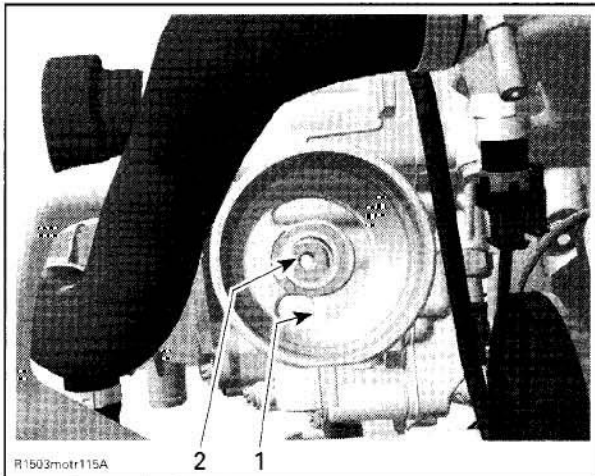

#### TYPICAL

1. Inlet bore from the oil pump to the oil filter
2. Outlet bore to the engine oil providing system

#### Installation

For installation, reverse the removal procedure. Pay attention to the following details.

Install a new oil filter.

Install O-ring on oil filter cover.

**NOTE:** In salt water area, it is recommended to coat mating surface of cover with Super Lube grease (P/N 293 600 016).

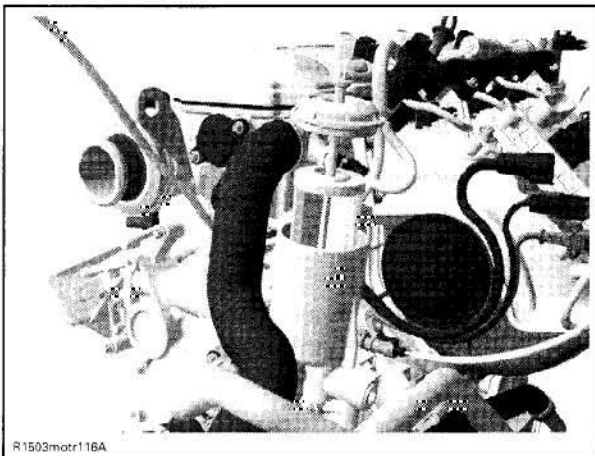

#### TYPICAL

Torque oil filter screw to 9 N•m (80 lbf•in).

## INSPECTION

### ENGINE OIL PRESSURE

**NOTE:** Depending on the oil pressure switch, the threshold value to send a signal of low oil pressure may vary from a minimum of 180 kPa (26 PSI) to a maximum of 220 kPa (32 PSI).

**NOTE:** The engine pressure test should be done with a warm engine and the recommended oil.

Use oil pressure gauge (P/N 529 035 709) and hose adaptor (P/N 529 035 652) and install where shown. A 1/8 NPT pipe extension may ease the installation.

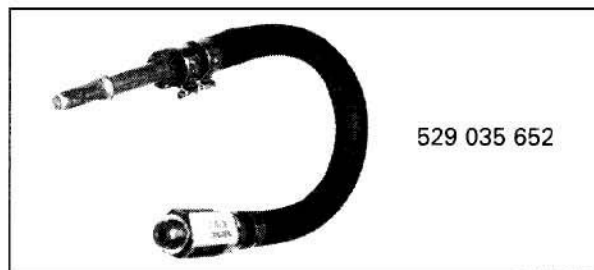
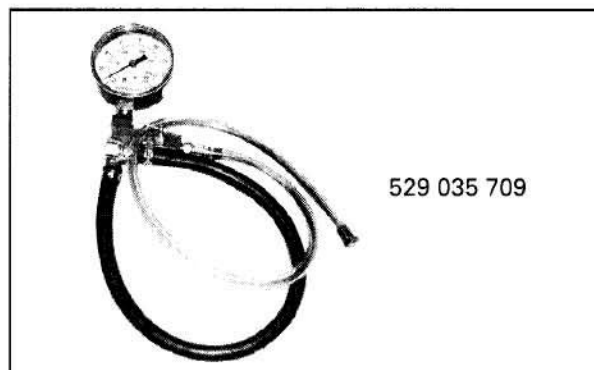

#### Test at the Oil Pressure Switch Location

Remove oil pressure switch and install gauge.

**Section 03 ENGINE**  
Subsection 08 (LUBRICATION SYSTEM)

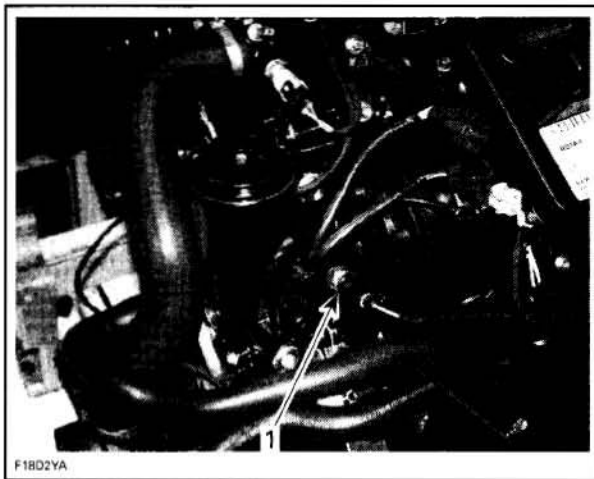

**INSTALLATION AT PRESSURE SWITCH LOCATION**  
1. Remove oil pressure switch and install gauge here

To prevent the EMS to go in limp home mode (at 2500 RPM) or to generate a fault code, start engine, THEN ground OPS connector to engine.

Read oil pressure at different RPM as per following table.

<b>OIL PRESSURE MEASURED AT PRESSURE SWITCH LOCATION</b>	
ALL 1503 4-TEC ENGINES kPa (PSI)	
Idle (cold)	448 - 648 (65 - 94) for a very short time
Idle (at 80°C (176°F))	Min. 228 (33)
4000 - 7500	400 - 496 (58 - 72)

Reinstall oil pressure switch.

### Test at the Cylinder Head Location

The oil pressure may be measured from cylinder head if desired.

Remove plug located on cylinder head and install gauge.

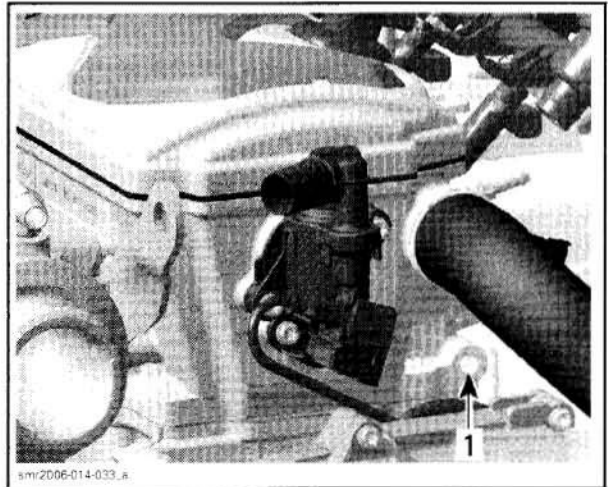

**INSTALLATION AT CYLINDER HEAD**  
1. Remove plug and install gauge here

Start engine and read pressure at different RPM as per following table.

<b>OIL PRESSURE MEASURED AT CYLINDER HEAD LOCATION</b>	
ALL 1503 4-TEC ENGINES kPa (PSI)	
Idle (cold)	448 - 648 (65 - 94) for a very short time
Idle (at 80°C (176°F))	Min. 228 (33)
4000 - 7500	400 - 496 (58 - 72)

Reinstall plug.

## PROCEDURES

### PTO OIL STRAINER

**NOTE:** The oil strainer does not need to be cleaned at every oil change. Clean it during other inspections, especially when the engine is disassembled.

#### Removal

Remove:

- engine oil (refer to *OIL CHANGE*)
- PTO cover no. 5 (refer to *PTO COVER AND MAGNETO* section)
- oil strainer no. 6.



## Section 03 ENGINE

### Subsection 08 (LUBRICATION SYSTEM)

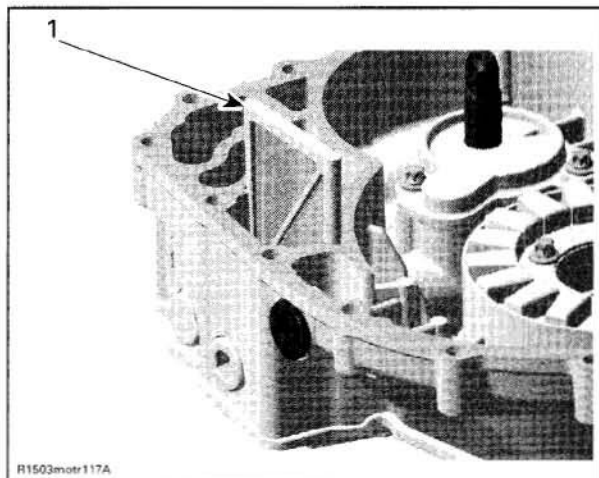

1. Oil strainer

#### Cleaning and Inspection

Clean oil strainer with a part cleaner then use an air gun to dry it.

#### **⚠ WARNING**

Always wear eye protector. Chemicals can cause a rash break out in and an injury to your eyes.

Check and clean the oil outlet area for dirt and other contaminations.

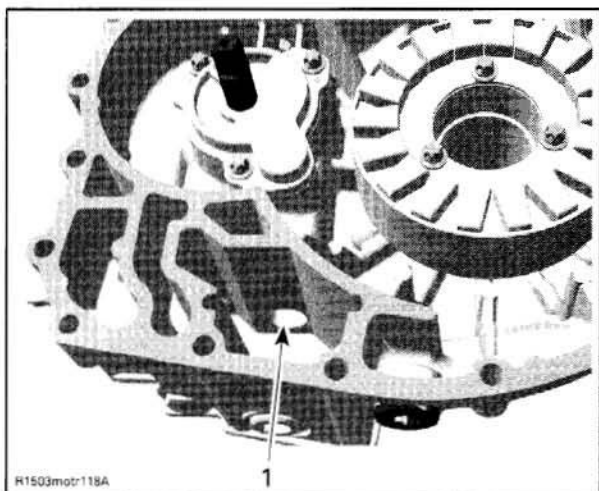

1. Oil inlet to the oil pump

#### Installation

For installation, reverse the removal procedure.

Refill engine at the proper level with the recommended oil. Refer to *OIL LEVEL VERIFICATION* for the procedure.

#### SUCTION PUMP OIL STRAINER

**NOTE:** The oil strainer does not need to be cleaned at every oil change. Clean it during other inspections, especially when the engine is disassembled.

#### Removal

**NOTE:** The intercooler outlet hose (if so equipped) does not need to be removed to remove the oil strainer.

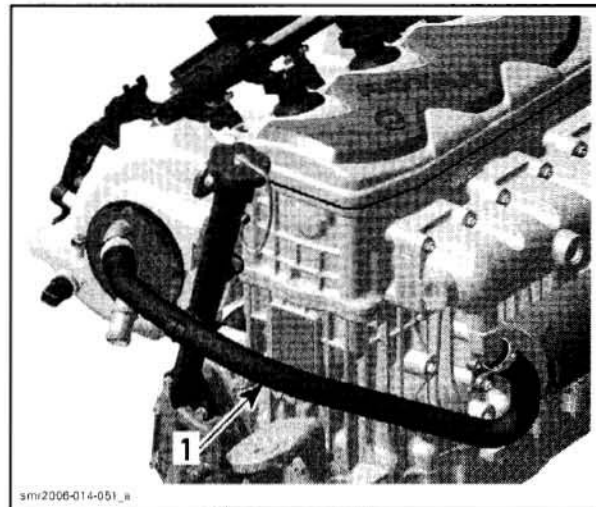

TYPICAL — SUPERCHARGED INTERCOOLED ENGINES  
1. Outlet hose

- Detach intake hose from throttle body (naturally aspirated engine only).
- Remove other required parts from vehicle to access the oil suction pump cover.
- Remove retaining screws from oil filler tube no. 39.
- Remove oil filler tube no. 14.
- Remove retaining screws from suction pump cover no. 40.
- Place rags under cover to prevent spillage. If spillage occurs, clean with the pulley flange cleaner (P/N 413 711 809).

#### **⚠ WARNING**

Wear safety glasses and work in a well ventilated area when working with strong chemical products. Also wear suitable non-absorbent gloves to protect your hands.

- Remove oil suction pump cover no. 41.
- Remove oil strainer from the suction pump cover no. 12.



**Section 03 ENGINE**  
**Subsection 08 (LUBRICATION SYSTEM)**

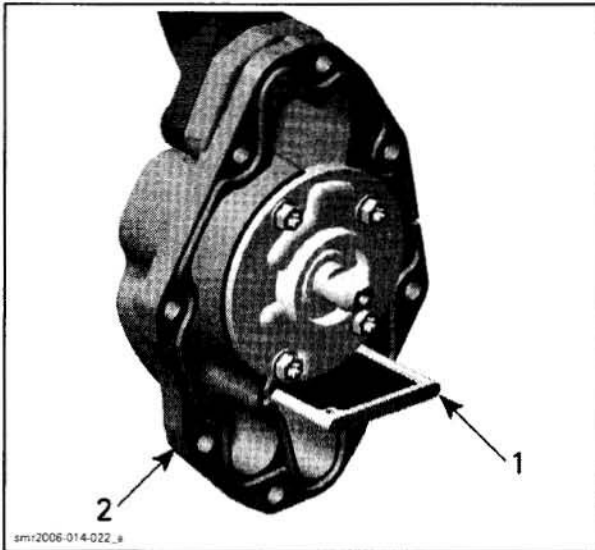

- 1. Oil strainer
- 2. Suction pump cover

**Cleaning and Inspection**

Clean oil strainer with a part cleaner then use an air gun to dry it.

**⚠ WARNING**

Always wear eye protector. Chemicals can cause a rash break out in and an injury to your eyes.

Inspect rubber ring gaskets.

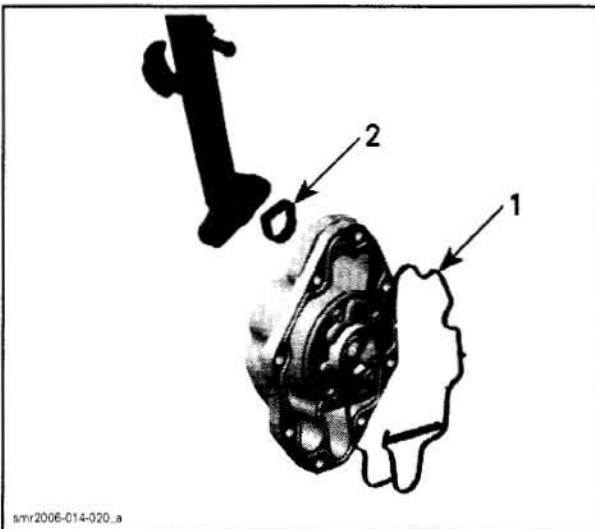

- TYPICAL — NATURALLY ASPIRATED AND SUPERCHARGED ENGINES**
- 1. Rubber ring gasket
  - 2. Rubber ring gasket

If rubber rings are brittle, cracked or hard, replace them.

Clean both contact surfaces of oil suction pump cover.

Check and clean the oil inlet and outlet area for dirt and other contaminations.

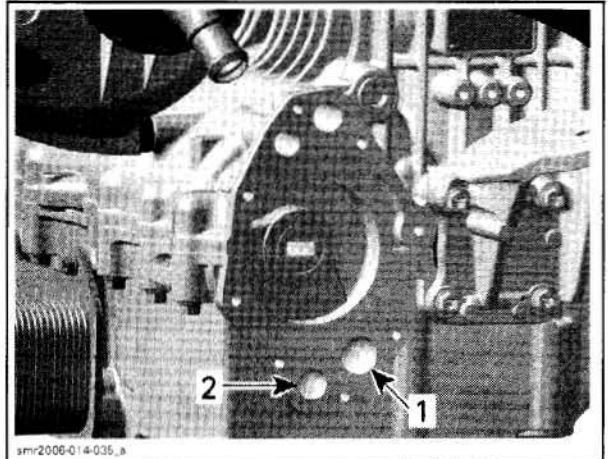

- TYPICAL**
- 1. Oil inlet
  - 2. Oil outlet

**Installation**

For installation, reverse the removal procedure.

Position screws according to their length as shown.

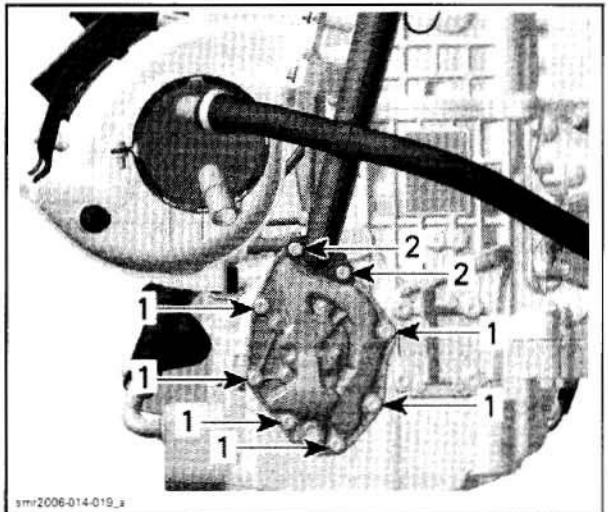

- TYPICAL**
- 1. Screws M6 x 25
  - 2. Screws stainless steel M6 x 45

Torque suction pump cover screws to 10 N•m (89 lbf•in) as per sequence illustrated below. Apply Loctite 243 (P/N 293 800 060) on threads.

## Section 03 ENGINE

### Subsection 08 (LUBRICATION SYSTEM)

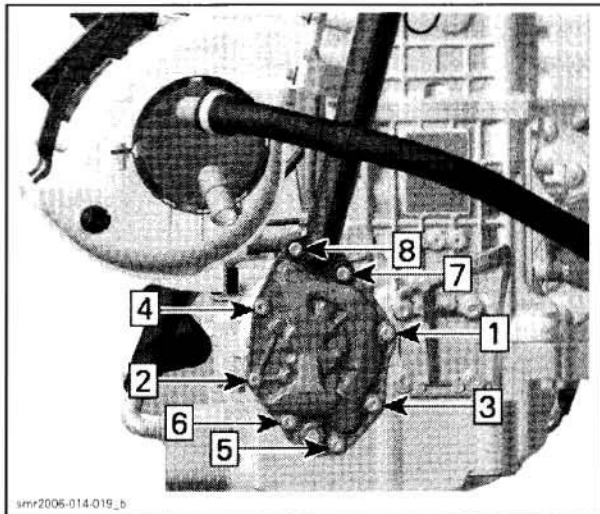

## ENGINE OIL PRESSURE REGULATOR

The oil pressure regulator is located on the bottom of the PTO housing.

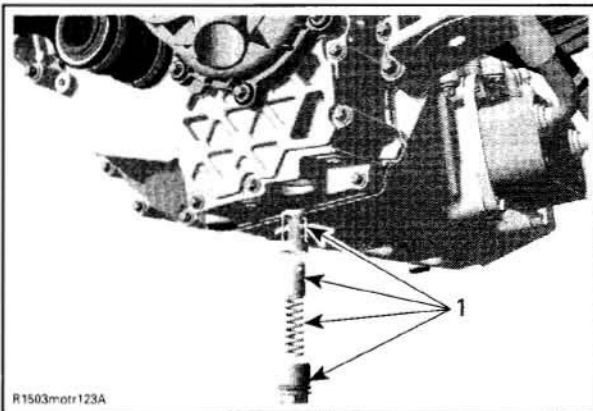

**TYPICAL**  
1. Oil pressure regulator

**NOTE:** The oil pressure regulator system opens when the oil pressure exceeds 400 kPa (58 PSI).

### Removal

Remove:

- engine oil (refer to *OIL CHANGE*)
- oil pressure regulator plug no. 15, compression spring no. 16, valve piston no. 17 and valve piston guide no. 18.

### **⚠ WARNING**

Oil pressure regulator plug on oil pump housing is spring loaded.

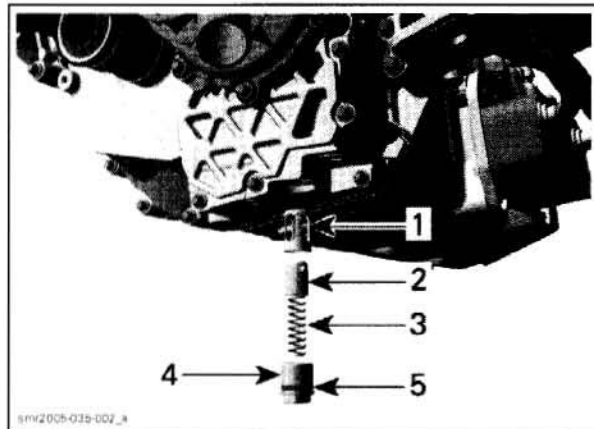

**TYPICAL**  
1. Valve piston guide  
2. Valve piston  
3. Compression spring  
4. Oil pressure regulator plug  
5. O-Ring

### Inspection

Inspect valve piston and valve piston guide for scoring or other damages.

Check compression spring for free length.

COMPRESSION SPRING FREE LENGTH	
NEW NOMINAL	58.2 mm (2.291 in)
SERVICE LIMIT	50.3 mm (1.980 in)

Replace parts if important wear or damage are present.

Clean bore and threads in the PTO housing from metal shavings and other contaminations.

### Installation

For installation, reverse the removal procedure. Pay attention to the following details.

Be careful that the O-ring on plug screw is in place.

Torque plug screw to 12 N•m (106 lb•in) maximum. Apply Loctite 243 (P/N 293 800 060) on threads.

## OIL PRESSURE PUMP

The oil pressure pump is located in the PTO housing and is driven by the balance shaft.

### Removal

Remove:

- engine oil (refer to *OIL CHANGE*)
- PTO housing (refer to *PTO HOUSING AND MAGNETO* section)



**Section 03 ENGINE**  
Subsection 08 (LUBRICATION SYSTEM)

- water pump housing no. 19 and impeller no. 20 (refer to *COOLING SYSTEM* section)
- screws no. 21
- oil pump cover no. 22

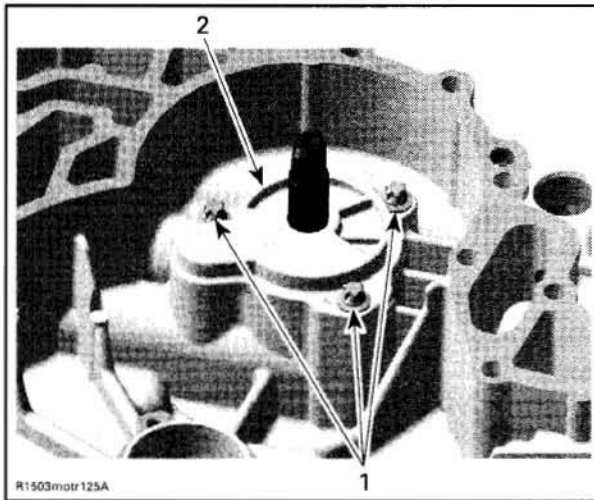

1. Screws
2. Oil pump cover

- outer oil pump rotor no. 23

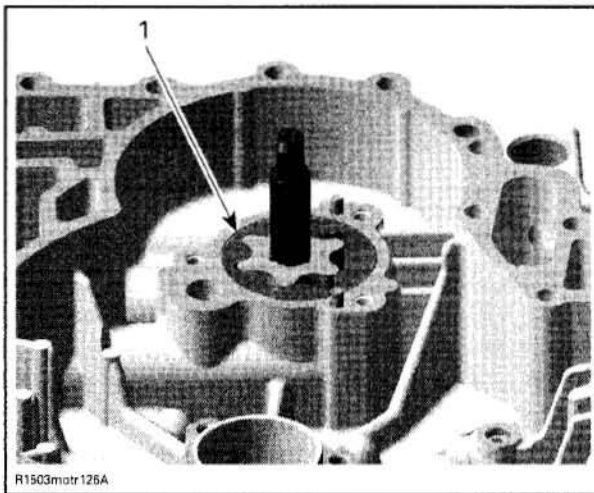

1. Outer oil pump rotor

- extract the water/oil pump shaft no. 24 from outside PTO housing with a pusher
- remove rotary seal no. 25 with a screwdriver

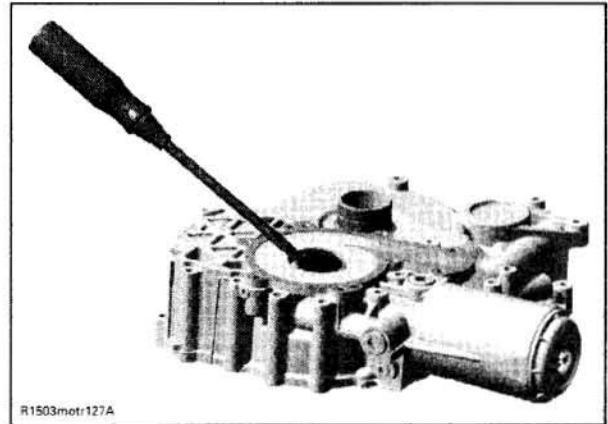

TYPICAL

**CAUTION:** Be careful not to damage the surface of the rotary seal bore in PTO housing cover.

- oil seal no. 26.

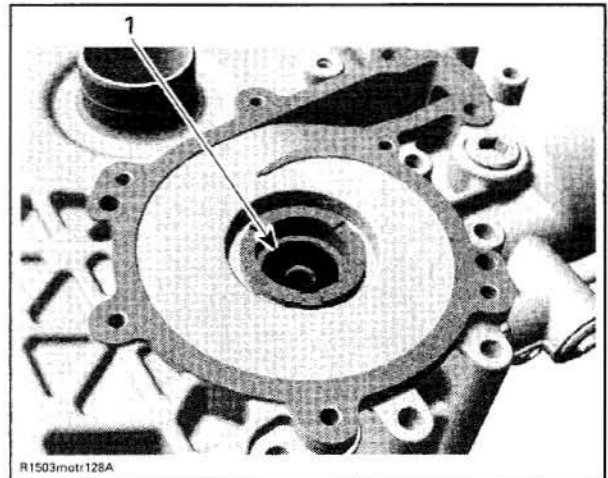

1. Oil seal

### Inspection

Inspect oil pump shaft, housing and cover for marks or other damages.

Check inner rotor for corrosion pin-holes or other damages. If so, replace oil pump shaft. Ensure to also check oil pump housing and cover and replace if damaged.



## Section 03 ENGINE

### Subsection 08 (LUBRICATION SYSTEM)

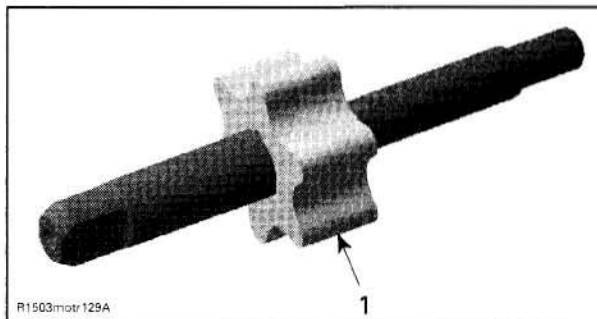

1. Pittings on the teeth

Using a feeler gauge, measure the clearance between inner and outer rotors.

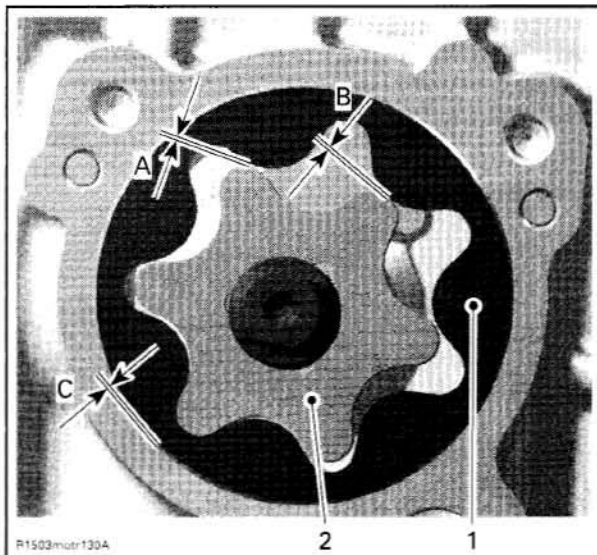

1. Outer rotor  
2. Inner rotor

OUTER AND INNER ROTOR CLEARANCE	
SERVICE LIMIT	
A	0.25 mm (.009 in)
B	
C	

If clearance between inner and outer rotors exceeds the tolerance, replace water/oil pump shaft. Ensure to also check oil pump housing and cover and replace if damaged.

If clearance between outer rotor and its bore in oil pump exceeds the tolerance, replace the complete oil pump and the PTO housing.

Using a vernier depth gauge, measure side wear as shown.

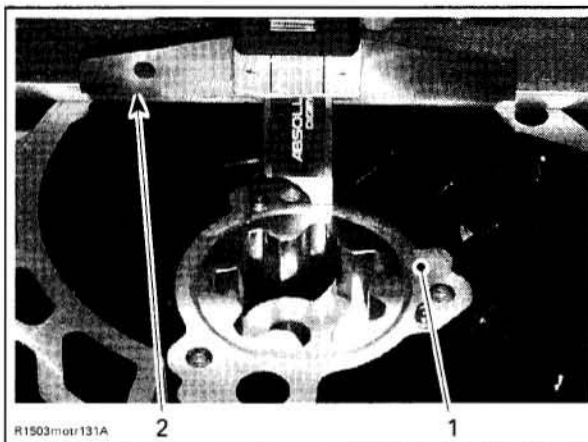

1. PTO housing surface  
2. Vernier depth gauge

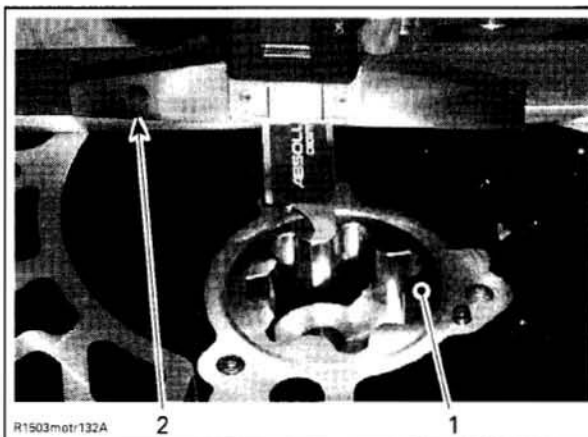

1. Oil pump outer rotor surface  
2. Vernier depth gauge

Difference between pump housing and outer rotor should not exceed 0.1 mm (.004 in). If so, replace the complete oil pump assembly.

**NOTE:** When the axial clearance of the oil pump shaft increases, the oil pressure decreases.

Check the inside of oil pump housing and its cover for scoring or other damages and replace if damaged.

### Installation

For installation, reverse the removal procedure. Pay attention to the following details.

**NOTE:** Never use oil in the press fit area of the rotary seal.

Push water/oil pump shaft seal in place by using thumb.

**Section 03 ENGINE**  
**Subsection 08 (LUBRICATION SYSTEM)**

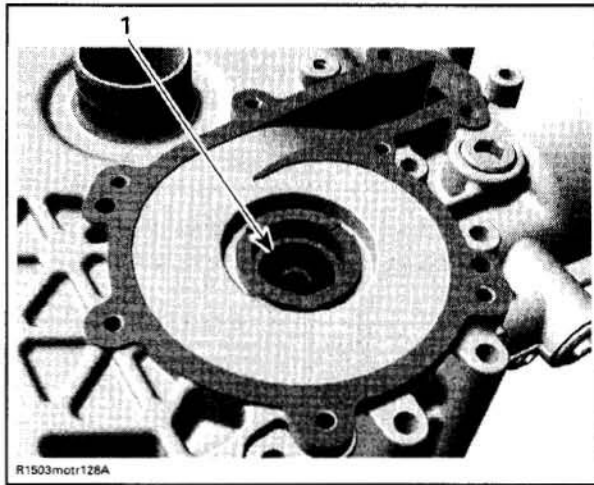

1. Oil seal

Install the new rotary seal by using the rotary seal pusher (P/N 529 035 823).

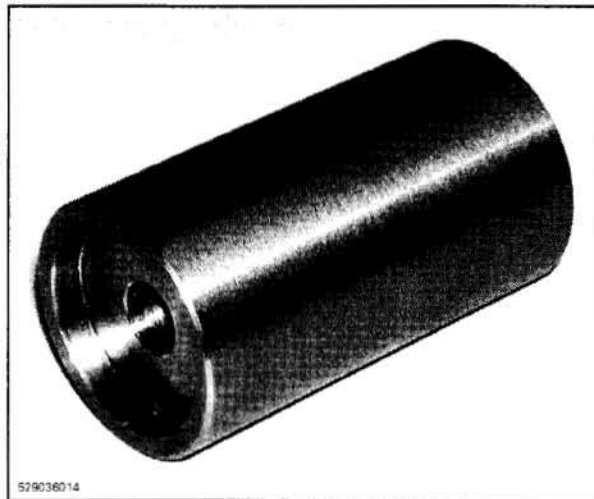

**CAUTION:** Never use a hammer for the rotary seal or water/oil pump shaft installation. Only use a press to avoid damaging the ceramic component.

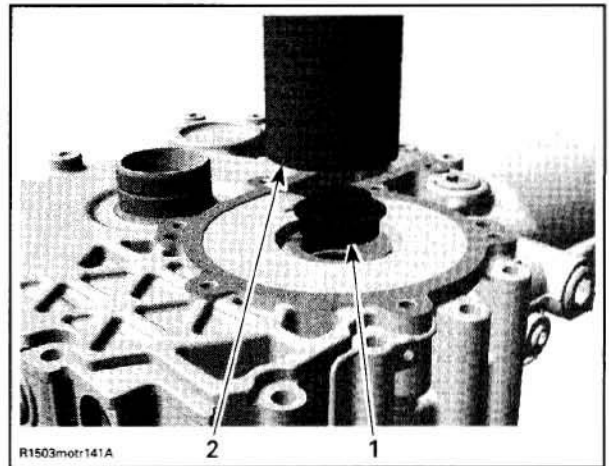

**TYPICAL**  
 1. Rotary seal  
 2. Rotary seal pusher

Install the water/oil pump shaft using the rotary seal pusher (P/N 529 035 823) on the opposite side to support the rotary seal. Use the oil seal guide (P/N 529 035 822) with a press.

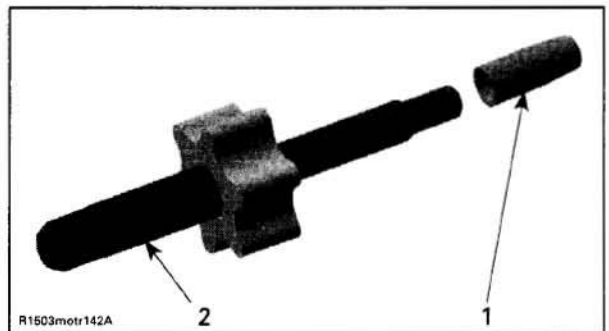

1. Oil seal guide  
 2. Water/oil pump shaft

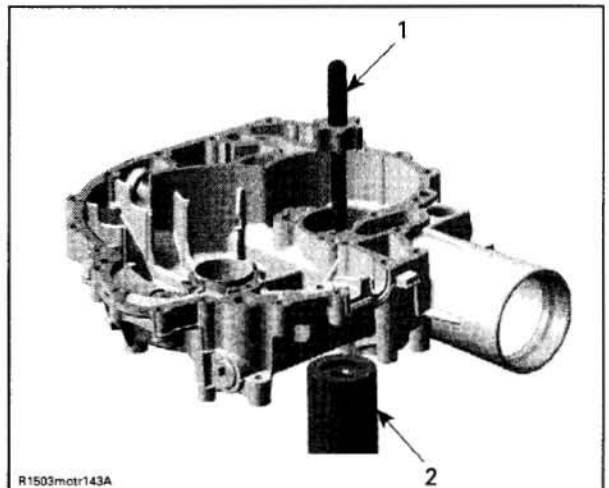

1. Water/oil pump shaft with oil seal guide  
 2. Rotary seal pusher



## Section 03 ENGINE

### Subsection 08 (LUBRICATION SYSTEM)

Tighten oil pump cover screws and torque to 10 N•m (89 lbf•in). Apply Loctite 243 (P/N 293 800 060) on threads.

#### Final Test

After engine is completely reassembled, start engine and make sure oil pressure is within specifications.

### OIL SUCTION PUMP

The oil suction pump is located on the front side of the engine inside of the oil suction pump housing at the bottom of the oil filler tube.

#### Removal

**NOTE:** The intercooler outlet hose (if so equipped) does not need to be removed to remove the oil suction pump.

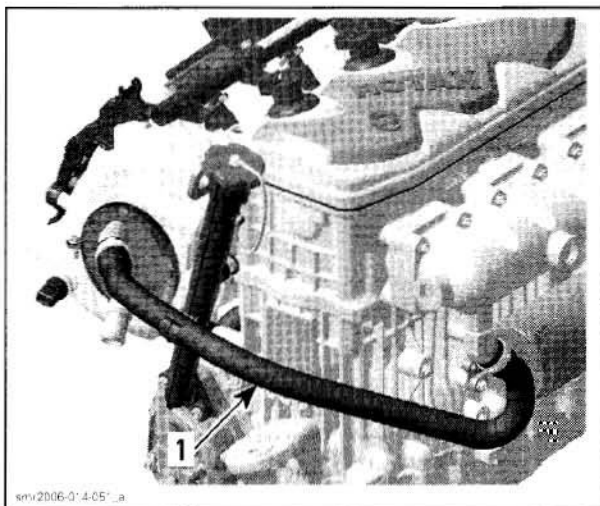

**TYPICAL — SUPERCHARGED INTERCOOLED ENGINES**  
1. Outlet hose

- Detach intake hose from throttle body (naturally aspirated engine only).
- Remove other required parts from vehicle to access the oil suction pump housing.
- Remove retaining screws from oil filler tube no. 39.
- Remove oil filler tube no. 14.
- Remove retaining screws no. 40.
- Place rags under cover to prevent spillage. If spillage occurs, clean with the pulley flange cleaner (P/N 413 711 809).

#### **⚠ WARNING**

Wear safety glasses and work in a well ventilated area when working with strong chemical products. Also wear suitable non-absorbent gloves to protect your hands.

- Remove the oil suction pump housing.
- Remove oil pump screws no. 27 and cover no. 42.

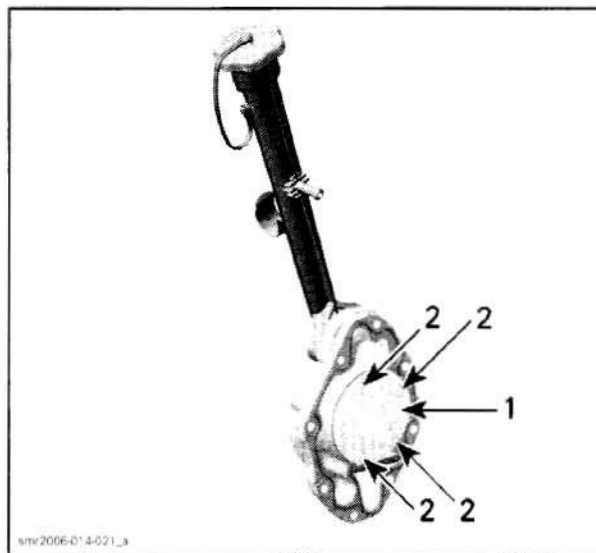

**TYPICAL**  
1. Oil pump cover  
2. Oil pump screws

- Remove oil pump shaft no. 29.
- Remove outer rotor no. 30.

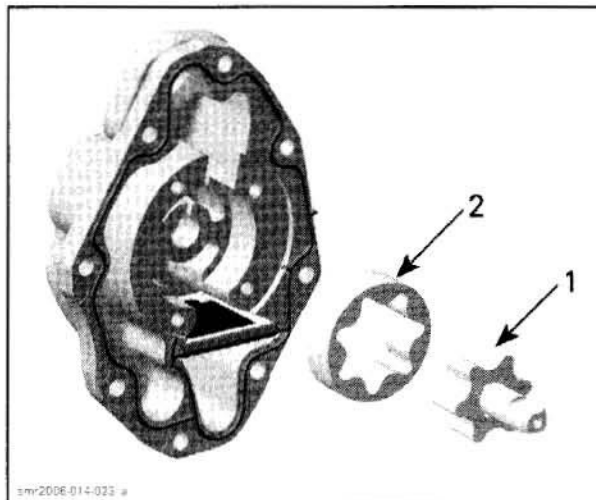

**TYPICAL**  
1. Oil pump shaft ass'y  
2. Outer rotor



**Section 03 ENGINE**  
Subsection 08 (LUBRICATION SYSTEM)

**Inspection**

Inspect oil pump shaft, housing and cover for marks or other damages.

Check inner rotor for corrosion, pin-holes or other damages. If so, replace oil pump shaft. Ensure to also check oil pump housing and cover and replace if damaged.

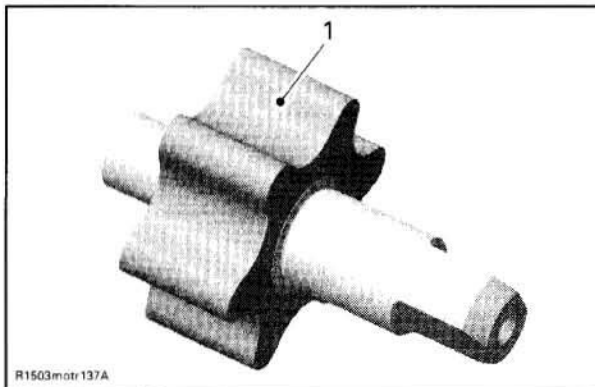

1. Pittings on the teeth

Using a feeler gauge, measure the clearance between inner and outer rotors.

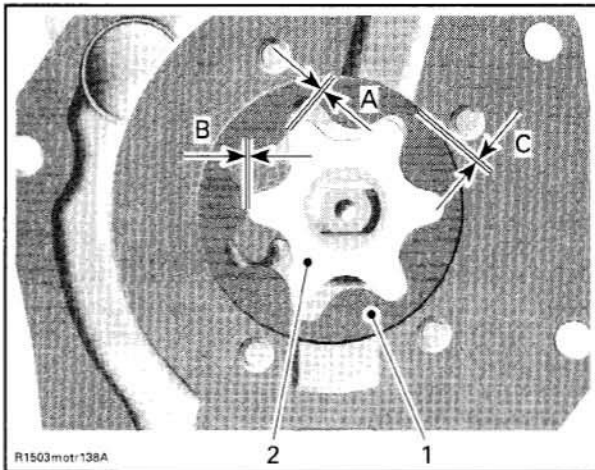

1. Outer rotor  
2. Inner rotor

OUTER AND INNER ROTOR CLEARANCE	
SERVICE LIMIT	
A	0.25 mm (.009 in)
B	
C	

If clearance between inner and outer rotors exceeds the tolerance, replace oil pump shaft. Ensure to also check oil pump housing and cover and replace if damaged.

If clearance between outer rotor and its bore in oil pump exceeds the tolerance, replace the complete oil pump and the PTO housing.

Using a vernier depth gage, measure side wear as shown.

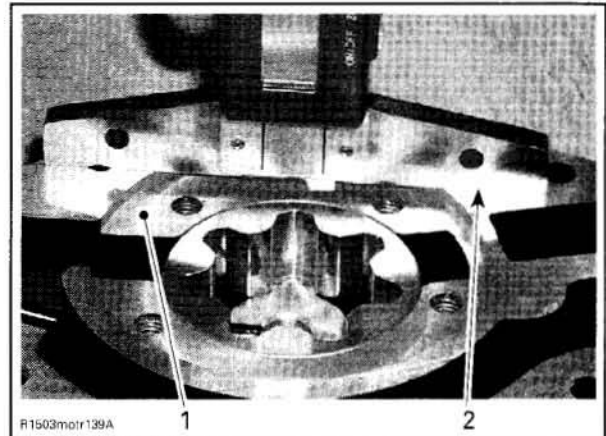

1. Oil pump housing surface  
2. Vernier depth gage

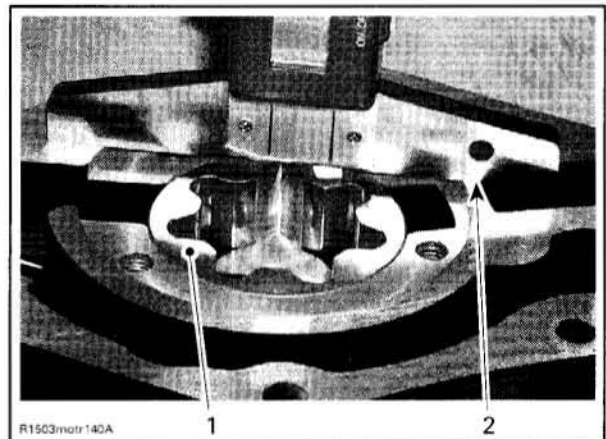

1. Oil pump outer rotor surface  
2. Vernier depth gage

Difference between pump housing and outer rotor should not exceed 0.1 mm (.004 in). If so, replace the complete oil pump assembly.

**NOTE:** When the axial clearance of the oil pump shaft assembly increases, the oil pressure decreases.

Check the inside of oil pump housing and its cover for scoring or other damages and replace if damaged.

**Installation**

For installation, reverse the removal procedure. Pay attention to the following details.

## Section 03 ENGINE

### Subsection 08 (LUBRICATION SYSTEM)

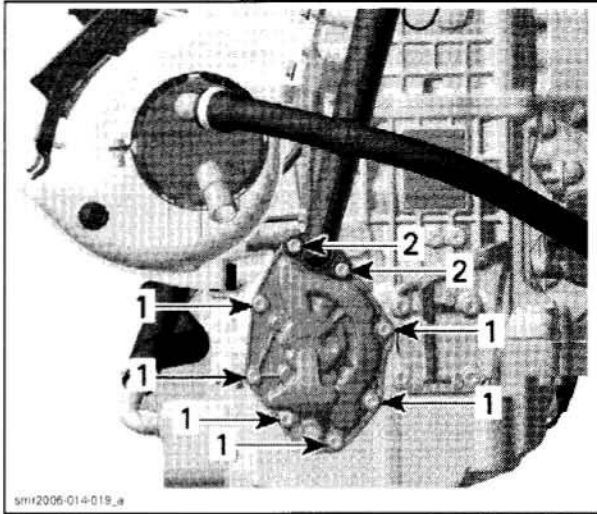

1. Screws M6 x 25
2. Screws M6 x 45

Torque oil pump cover screws to 10 N•m (89 lbf•in)

Tighten suction pump housing screws as per following sequence and torque to 10 N•m (89 lbf•in). Apply Loctite 243 (P/N 293 800 060) on threads.

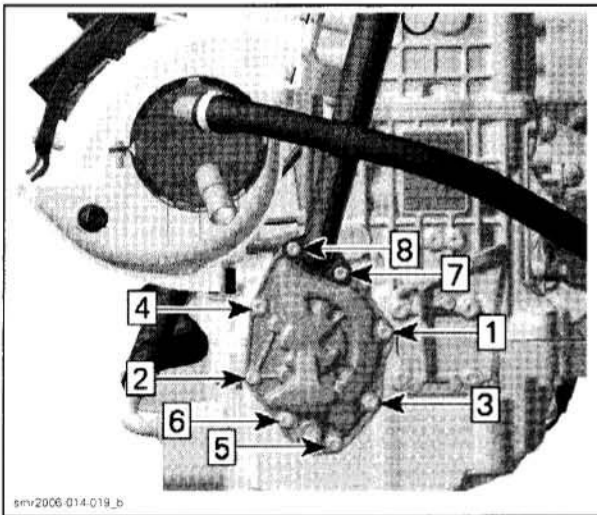

## OIL SEPARATOR COVER

### Removal

- Remove the ventilation hose from TOPS valve no. 8.

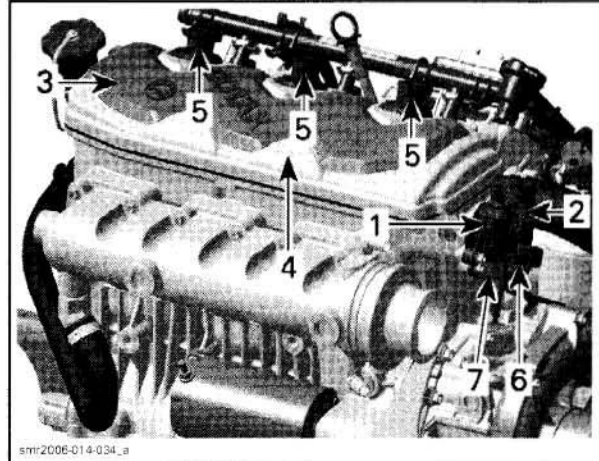

### TYPICAL

1. TOPS valve
2. Ventilation hose (not visible)
3. Valve cover cowl
4. Valve cover
5. Ignition coil
6. Crankshaft position sensor cable
7. Camshaft position sensor

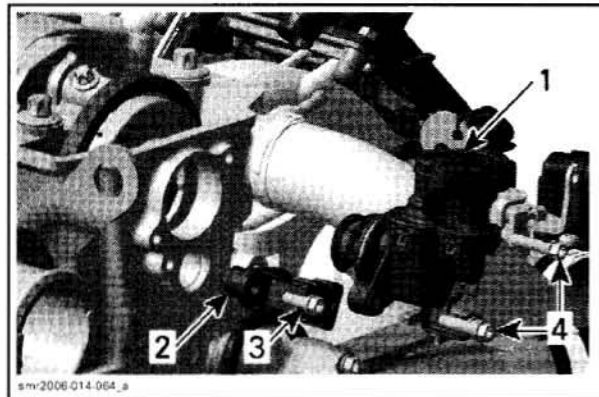

1. TOPS valve
2. Camshaft position sensor
3. Retaining screw
4. Retaining screws

- Remove CPS cable from TOPS valve.
- Remove retaining screws no. 13 holding TOPS valve.
- Remove TOPS valve.
- Remove retaining screw no. 52 and camshaft sensor no. 51.
- Take off engine cover and valve cover cowl no. 53.
- Remove ignition coils no. 48.
- Remove retaining screw no. 47 and valve cover no. 54.
- Remove thrust washer no. 11 from oil separator cover no. 10.



**Section 03 ENGINE**  
Subsection 08 (LUBRICATION SYSTEM)

**NOTE:** Make sure not to loose thrust washer when removing it from oil separator cover, otherwise thrust washer would fall into the PTO housing.

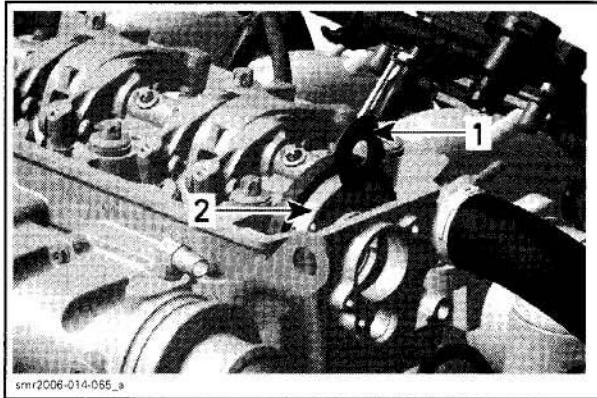

1. Thrust washer  
2. Oil separator

- Remove spark plug tube no. 49.
- Remove retaining screws no. 44 and rocker arm shaft together with rocker arms
- Remove chain guide no. 50 and camshaft guide no. 45.

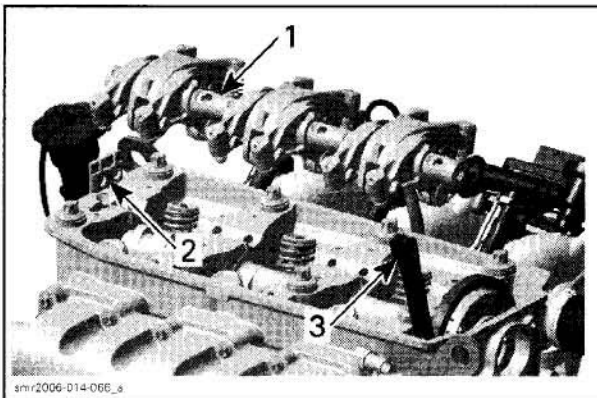

1. Rocker arm  
2. Camshaft guide  
3. Chain guide

- Move camshaft backwards as far as possible.
- Unclip oil separator cover no. 10 from timing gear.

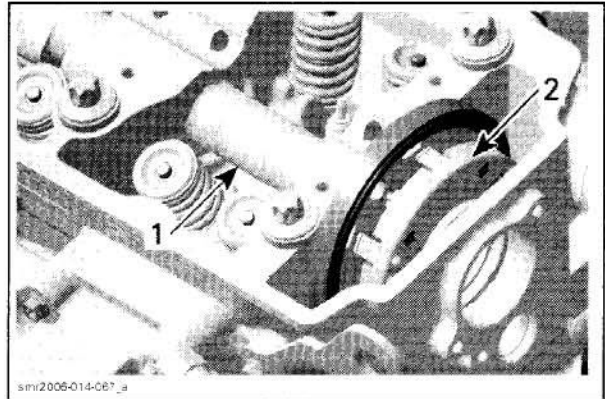

1. Camshaft  
2. Oil separator cover

**NOTE:** Be careful not to break the holding clips from oil separator cover when its removed from the timing gear.

### Inspection

If O-rings and V-rings are brittle, cracked or hard, replace them.

Clean all contact surfaces of oil separator cover and TOPS valve.

Inspect oil separator cover for marks or other damages. Ensure to check also the holding clips of oil separator cover and for thrust washer. If any damage is visible replace oil separator cover.

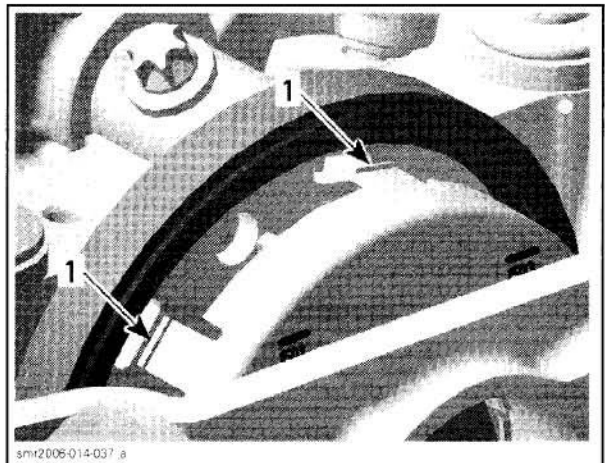

1. Holding clips

### Installation

For installation, reverse the removal procedure. Pay attention to the following details.

Apply grease on O-rings and V-rings.

**NOTE:** Make sure not to loose thrust washer when installed on oil separator cover.



## Section 03 ENGINE

### Subsection 08 (LUBRICATION SYSTEM)

**NOTE:** Oil separator cover and thrust washer need to be in a perfect even position with timing gear.  
Torque screws to 6 N•m (53 lbf•in). Apply Loctite 243 (P/N 293 800 060) on threads.

## TOPS VALVE

The TOPS valve is a mechanical device that does not require electrical supply for its operation.

### Removal

Remove ventilation hose from TOPS valve

Unscrew and remove the TOPS valve.

Remove O-ring and V-ring

**NOTE:** TOPS valve can not be disassembled.

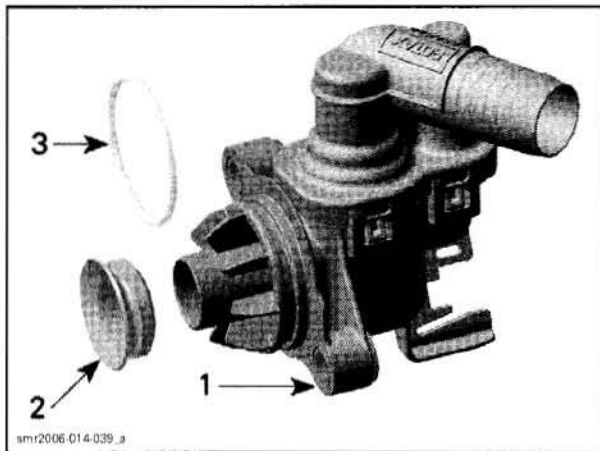

1. TOPS valve
2. V-ring
3. O-ring

### Inspection

If O-rings or V-rings are brittle, cracked or hard, replace them.

If TOPS valve is damaged, replace it

Clean all contact surfaces of TOPS valve.

Place a clean rag on valve inlet.

Blow air through inlet port. Air must flow freely to the outlet port.

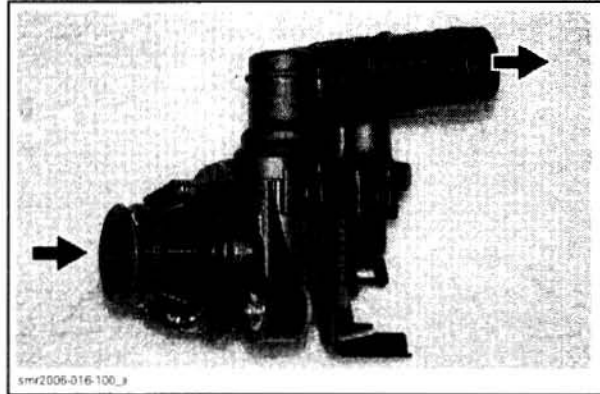

Turn valve upside down and blow air again. Air must not flow out.

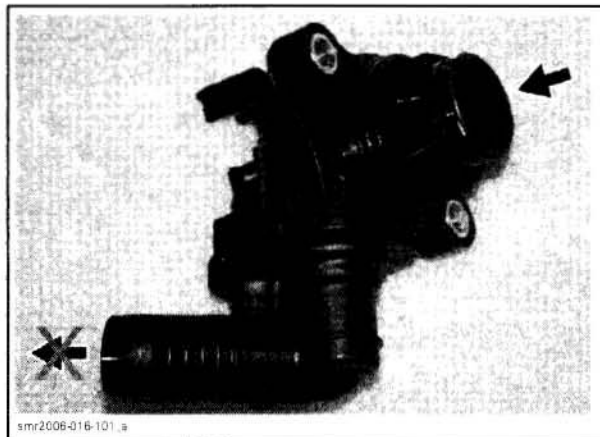

If test fails, replace valve.

### Installation

Install the TOPS valve with new O-ring and V-ring. Apply Loctite 243 (blue) on threads and torque to 6 N•m (53 lbf•in).

Reinstall remaining removed parts.

## OIL COOLER

The oil cooler is located below the air intake manifold.

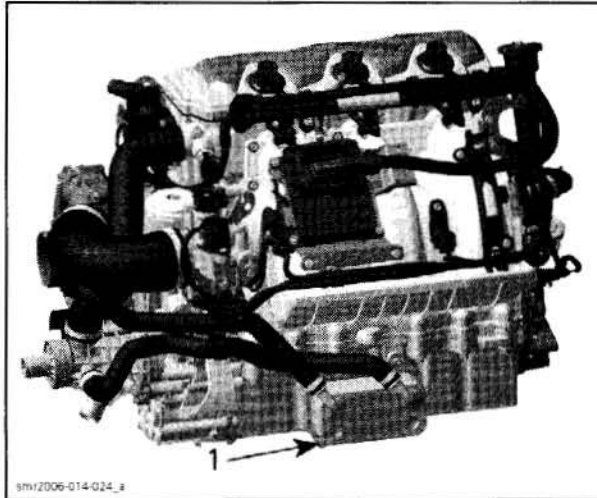

**TYPICAL**  
1. Oil cooler

### Removal

Remove:

- cooling hoses no. 34 and no. 35
- retaining screws no. 36
- oil cooler no. 37

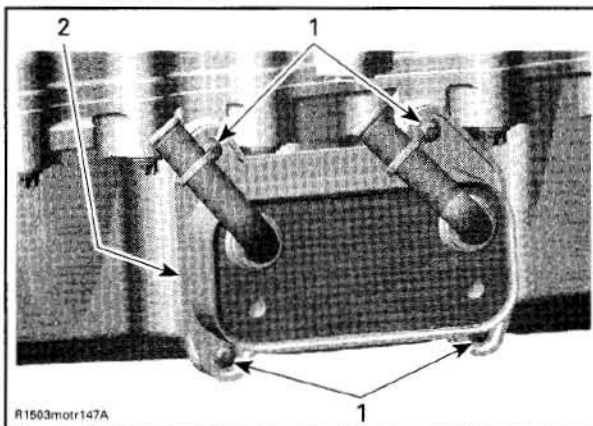

1. Screws  
2. Oil cooler

- O-rings no. 38.

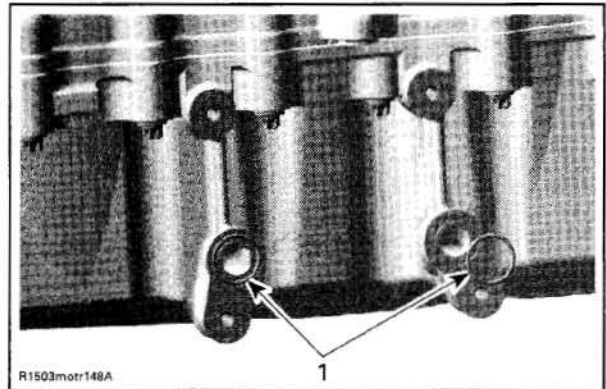

1. O-rings

### Inspection

If O-rings are brittle, cracked or hard, replace them.

Clean both contact surfaces of oil cooler.

Check and clean the oil inlet and outlet area for dirt and other contaminations.

### Installation

For installation, reverse the removal procedure. Pay attention to the following details.

Apply grease on O-rings.

Torque oil pump cover screws to 10 N•m (89 lbf•in). Apply Loctite 243 (P/N 293 800 060) on threads.

# COOLING SYSTEM

## SERVICE TOOLS

<b>Description</b>	<b>Part Number</b>	<b>Page</b>
oil seal protector .....	529 035 822 .....	123
pliers Oetiker 1099 .....	295 000 070 .....	119
rotary seal installer .....	529 035 823 .....	123
test cap .....	529 035 991 .....	116
vacuum/pressure pump .....	529 021 800 .....	117

## SERVICE PRODUCTS

<b>Description</b>	<b>Part Number</b>	<b>Page</b>
Loctite 243 .....	290 897 651 .....	120
premixed antifreeze .....	219 700 362 .....	117



**CLOSED LOOP COOLING SYSTEM**

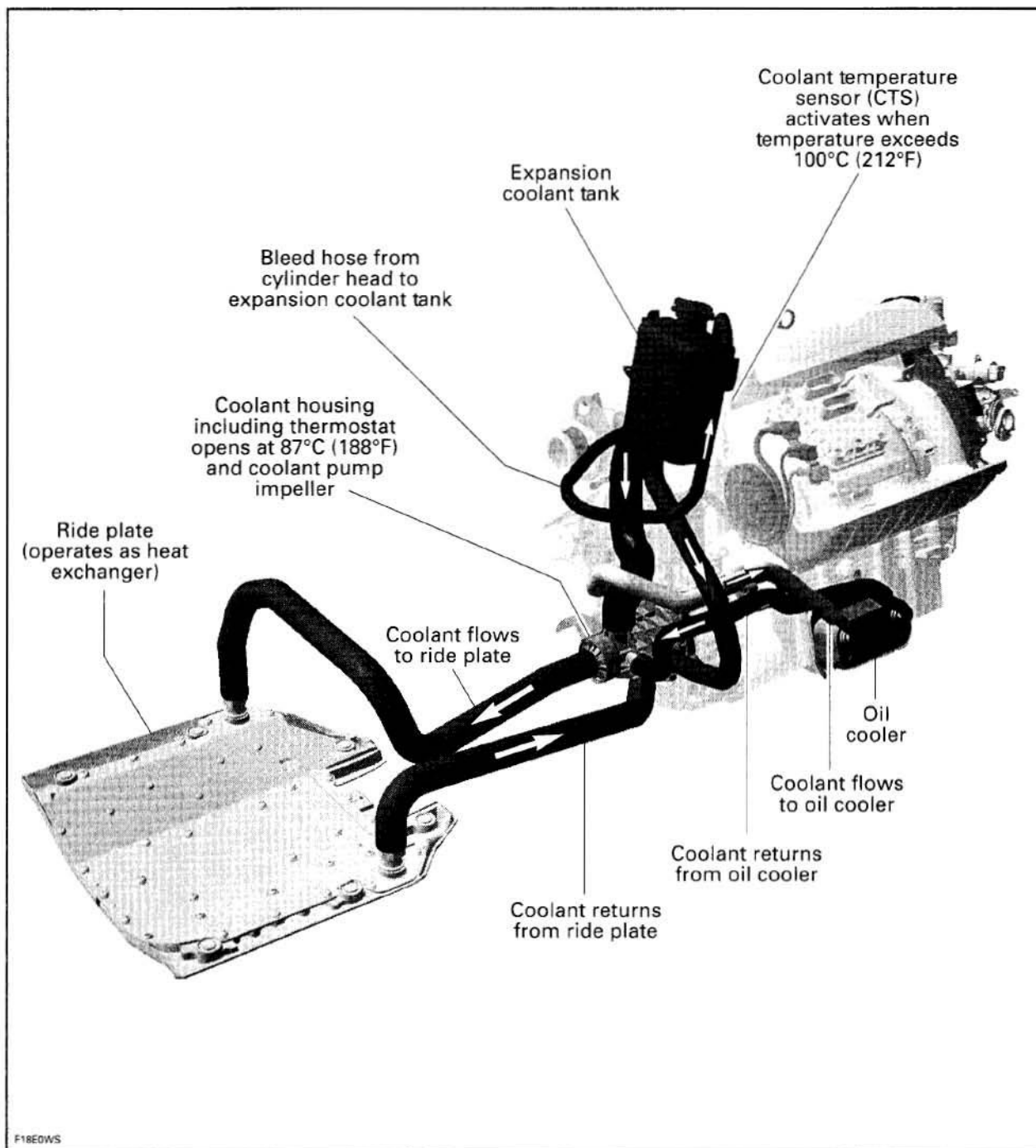

**ENGINE COMPONENTS**

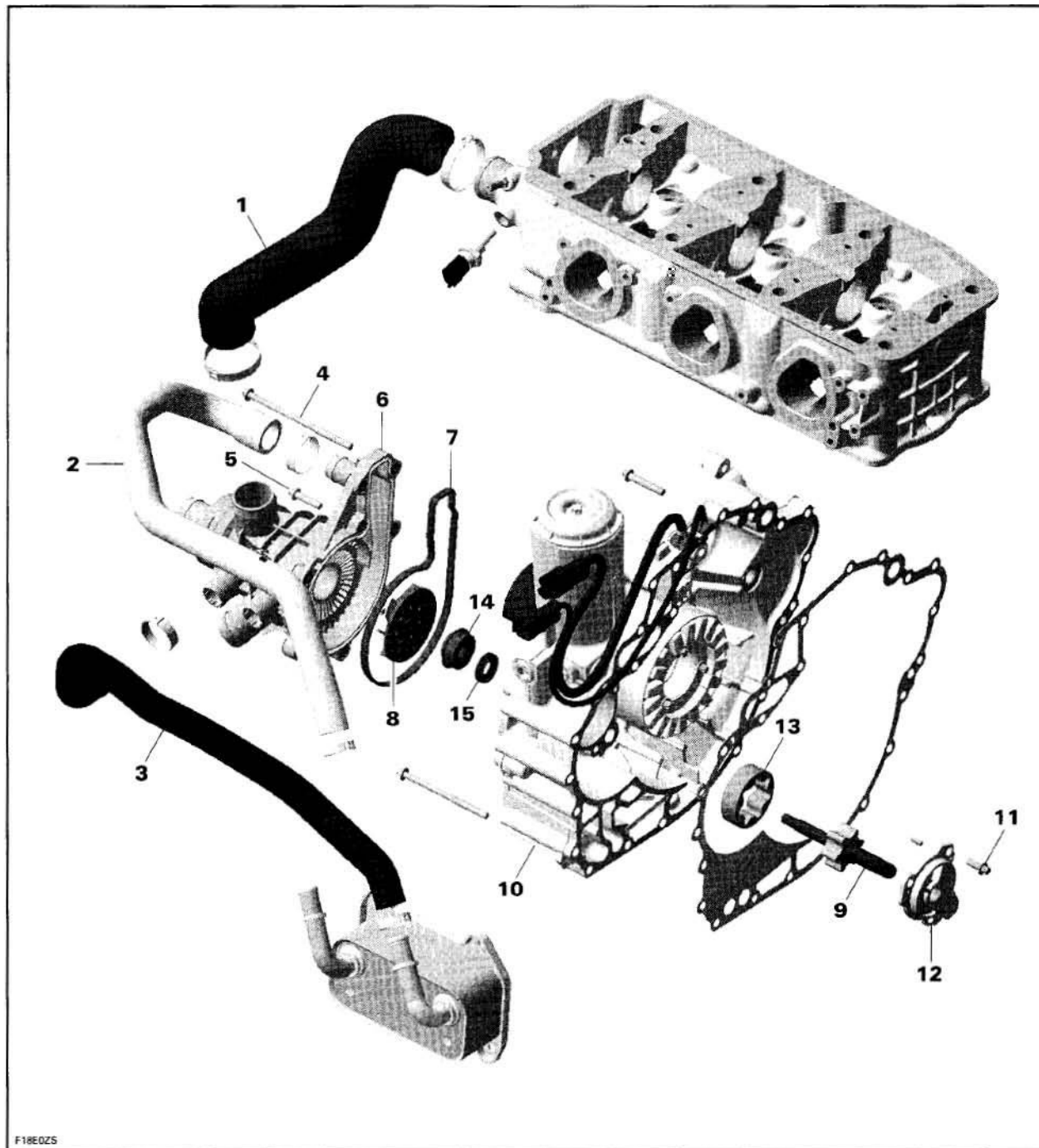

## GENERAL

### CIRCUIT

A closed loop cooling system is utilized on the 1503 4-TEC engines, which offers an efficient engine cooling while keeping dirt and salt water out of the cooling system. This system keeps the temperature constant and prevents internal engine corrosion.

A separate coolant expansion tank ensures that enough engine coolant is in the circuit during any operating condition.

The coolant flow comes from the water pump impeller into the cylinder block. It goes around the cylinders and straight up to the cylinder head. A smaller quantity of engine coolant enters the cylinder block on the exhaust side for a better cooling. In the cylinder head the water channels flow around the exhaust and then the intake valves and leave the engine through a large hose. From there the coolant goes back to the water pump housing and depending on the engine temperature, it flows through the thermostat directly back to the water pump impeller, or it takes its way through the ride plate which operates as a heat exchanger.

Engine coolant is also directed towards the oil cooler (coolant type).

Coolant temperature sensor and bleed nipple are located on the cylinder head.

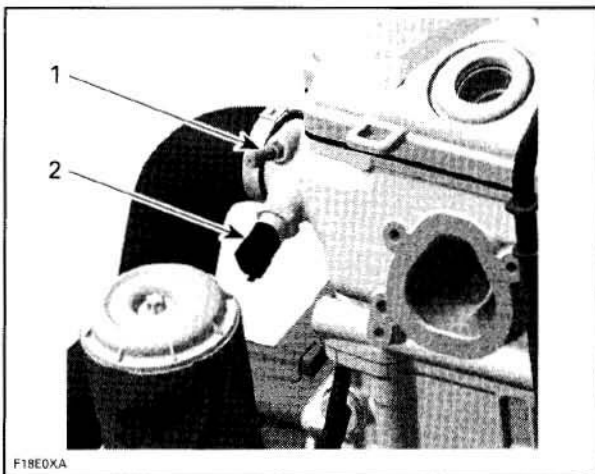

1. Bleed nipple  
 2. Coolant temperature sensor (CTS)

**CAUTION:** Never modify cooling system arrangement, otherwise serious engine damage could occur.

## TECHNICAL SPECIFICATIONS

TYPE	Closed loop cooling system.
COOLANT FLOW	Flow from water pump.
TEMPERATURE CONTROL	Thermostat.
SYSTEM BLEEDING	Self-bleed type through expansion tank (hose at uppermost point of circuit).
MONITORING BEEPER	Turns on at 100°C (212°F) on naturally aspirated engines. Turns on at 110°C (230°F) on supercharged engines.
COOLANT LIFE CYCLE	100 hours or 1 year. Should be replaced before storage.

## INSPECTION

### PRESSURE CAP

Using a pressure cap tester, check pressure cap efficiency. If the efficiency is feeble, install a new 90 kPa (13 PSI) cap (do not exceed this pressure).

### HOSES AND CLAMPS

Check general condition of hoses and clamp tightness.

### COOLING SYSTEM LEAK TEST

#### **⚠ WARNING**

To avoid potential burns, do not remove the expansion tank cap or loosen the ride plate drain plug if the engine is hot.

Install the test cap (P/N 529 035 991).

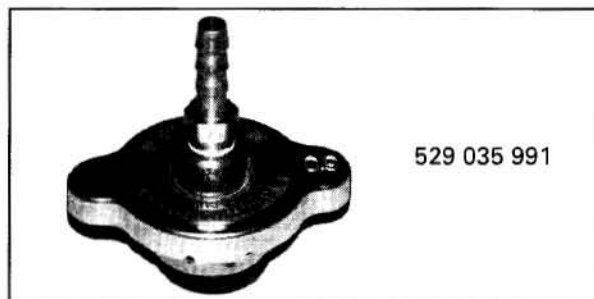

**NOTE:** It is not necessary to install a hose pincher on overflow hose.



Connect the vacuum/pressure pump (P/N 529 021 800) to test cap and pressurize system through coolant expansion tank to 90 kPa (13 PSI).

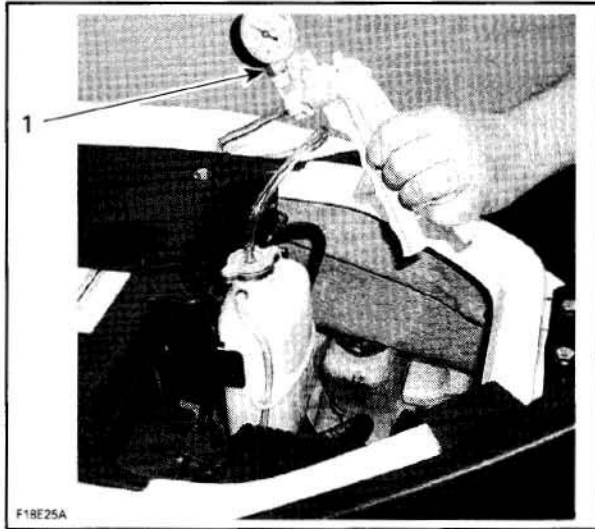

**TYPICAL**  
1. Vacuum/pressure pump

Check all hoses, ride plate, engine and oil cooler for coolant leaks. Spray a soap/water solution and look for air bubbles.

Check the leak indicator hole if there is oil or coolant. If so, replace appropriate water pump shaft seal.

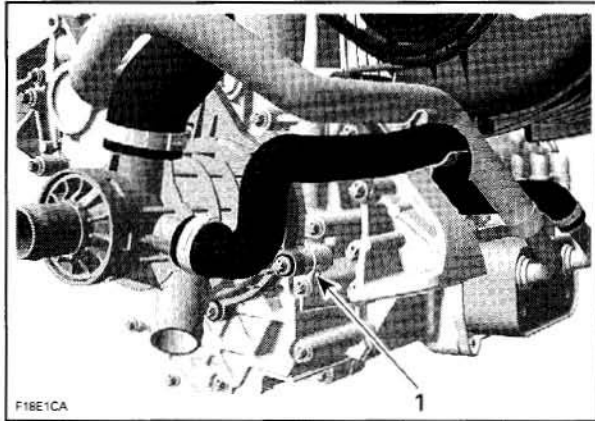

1. Leak indicator hole

## MAINTENANCE

### COOLANT REPLACEMENT

#### **⚠ WARNING**

To avoid potential burns, do not remove the expansion tank cap or loosen the ride plate drain plug if the engine is hot.

#### Recommended Coolant

Use premixed antifreeze (P/N 219 700 362) or a blend of 50% antifreeze with 50% demineralized water.

**NOTE:** Using a blend of 40% antifreeze with 60% demineralized water will improve the cooling efficiency when watercraft is used in particularly hot weather and/or hot water condition.

To prevent antifreeze deterioration, always use the same brand. Never mix different brands unless cooling system is completely flushed and refilled.

**CAUTION:** To prevent rust formation or freezing condition in cold areas, always replenish the system with 50% antifreeze and 50% demineralized water. Pure antifreeze will freeze at a higher temperature than the optimal water/antifreeze mix. Always use ethylene glycol antifreeze containing corrosion inhibitors specifically recommended for aluminum engines. Using water tap instead of demineralized water, would contribute to make deposits in cooling system and to reduce antifreeze efficiency. This could lead to engine overheating.

#### Draining the System

#### **⚠ WARNING**

Never drain or refill cooling system when engine is hot.

Remove coolant expansion tank cap.

To drain cooling system, unscrew cooling system drain plug at the rear of ride plate.

**NOTE:** Raising the front of the vehicle will contribute to drain the cooling system.

## Section 03 ENGINE

### Subsection 09 (COOLING SYSTEM)

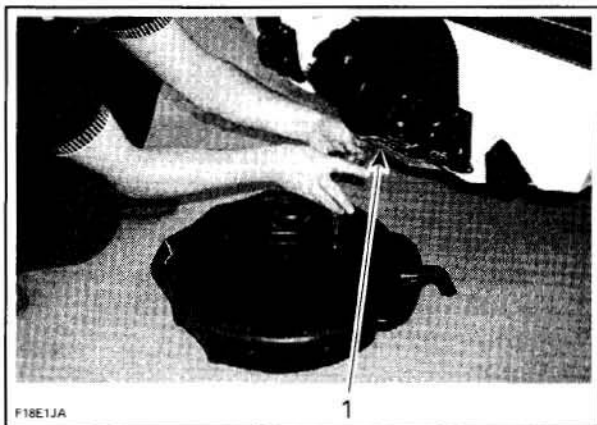

1. Cooling drain plug

Use an appropriate container to collect coolant. Dispose coolant as per local regulations.

Do not reinstall drain plug at this time.

### Cleaning the System

**CAUTION:** Cleaning the cooling system as per the following procedure is required when engine overheats (assuming everything else is operating normally) or each time coolant is replaced.

Drain the cooling system. Clean thoroughly using the Valvoline Zerex Super Cleaner (or equivalent).

Add the cleaning product in coolant expansion tank then fill cooling system with demineralized water.

Reinstall cap on coolant expansion tank.

Install watercraft in a water tank or ride on a water plane. Start engine and run for approximately 15 minutes mostly at full throttle.

**IMPORTANT:** Ensure thermostat opens so that the cleaning product flows in ride plate properly.

Stop engine and let the cleaning product work for 12 to 16 hours.

Thereafter, engine can be run one last time to soak off deposits.

Drain and thoroughly rinse the cooling system with clean fresh water.

Refill cooling system as described below.

### Refilling the System

Watercraft should be level, engine cold and drain plug removed for refilling.

Place a container under drain plug to collect antifreeze.

Ask someone to pour antifreeze in expansion tank while watching antifreeze and air bubble flowing out through drain hole. When no air bubbles escape, reinstall drain plug. Torque to 8.3 N•m (73 lbf•in).

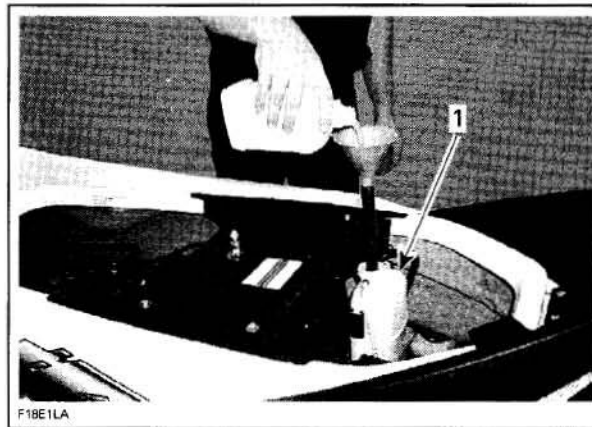

1. Pour antifreeze/water mix in expansion tank

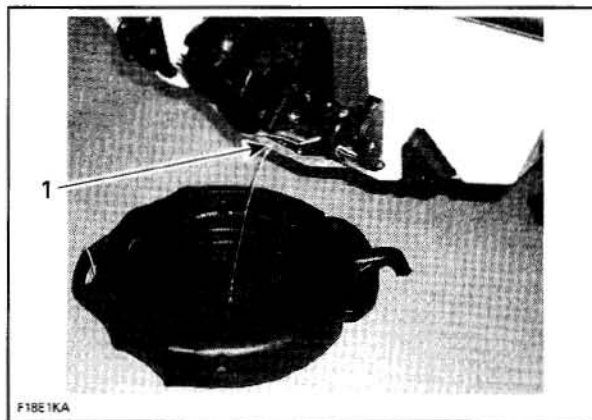

1. Watch air bubbles flowing here

Continue to pour and fill expansion tank between marks.



**Section 03 ENGINE**  
**Subsection 09 (COOLING SYSTEM)**

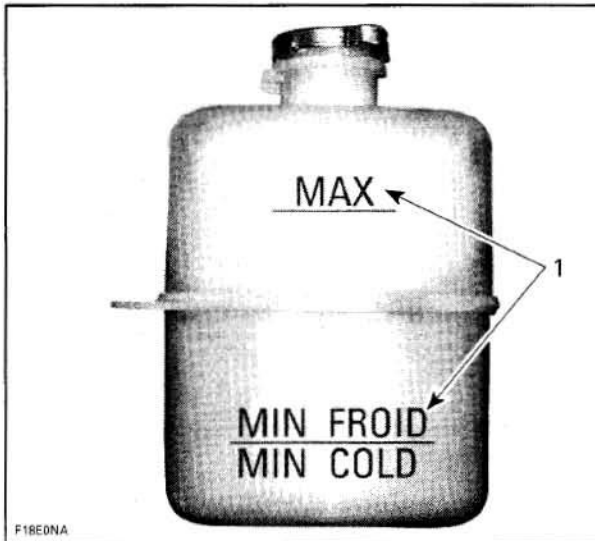

F18E0NA

1. Level between marks when engine is cold

Do not install pressure cap at this time. Properly cool exhaust system by installing a garden hose. Refer to *STORAGE* section. Start engine and let run for 2 minutes. Stop engine and wait 15 minutes to cool down. Refill tank as necessary. Repeat this run-stop cycle 2 - 3 times until thermostat opens and stop engine.

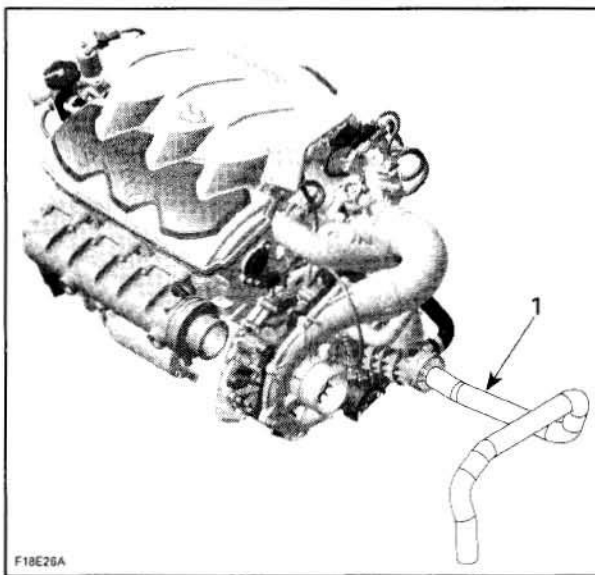

F18E26A

1. This hose becomes hot when thermostat opens

Last, refill expansion tank and install pressure cap. When engine has completely cooled down, recheck coolant level in radiator and coolant tank and top up if necessary.

Test the density of the coolant using an antifreeze hydrometer.

**NOTE:** Follow hydrometer manufacturer instructions for proper use.

The reading should be some degrees below the coldest temperature you expect in the area where the watercraft is to be used. Add demineralized water or antifreeze accordingly. Refill to the proper level.

**CAUTION:** Pure antifreeze will freeze at a higher temperature than the optimal water/antifreeze mix. Using water tap instead of demineralized water, would contribute to make deposits in cooling system and to reduce antifreeze efficiency. This could lead to engine overheating.

## PROCEDURES

### CLAMPS

#### Replacement

To cut or secure Oetiker clamps of cooling system hoses, use the pliers Oetiker 1099 (P/N 295 000 070).

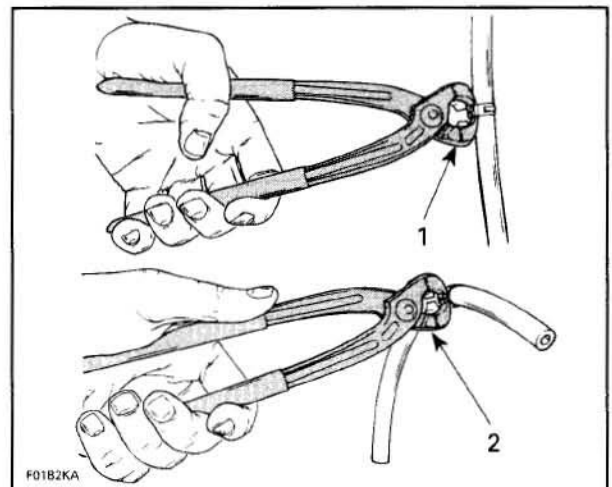

F01B2KA

1. Cutting clamp  
2. Securing clamp



## Section 03 ENGINE

### Subsection 09 (COOLING SYSTEM)

#### WATER PUMP HOUSING



1. Water pump housing

#### Removal

##### Supercharged Engines

Remove supercharger inlet and outlet hoses to make room.

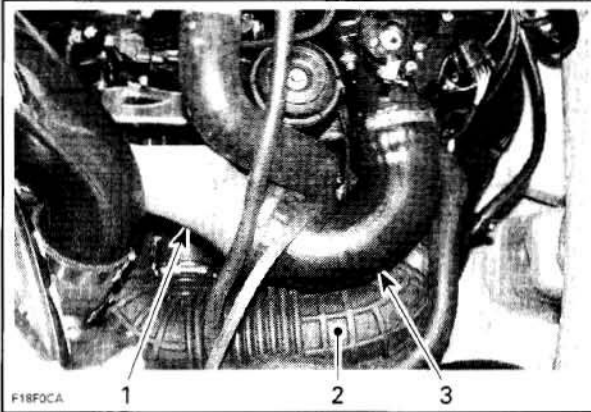

1. Supercharger  
2. Inlet hose  
3. Outlet hose

#### All Engines

Drain cooling system and engine oil.

Remove from housing:

- ride plate inlet and outlet hoses
- cylinder head outlet hose no. 1
- oil cooler inlet hose no. 2
- oil cooler outlet hose no. 3
- screws no. 4 and no. 5 retaining water pump housing no. 6
- water pump housing no. 6.

#### Inspection

Check if gasket no. 7 is brittle, hard or damaged and replace as necessary.

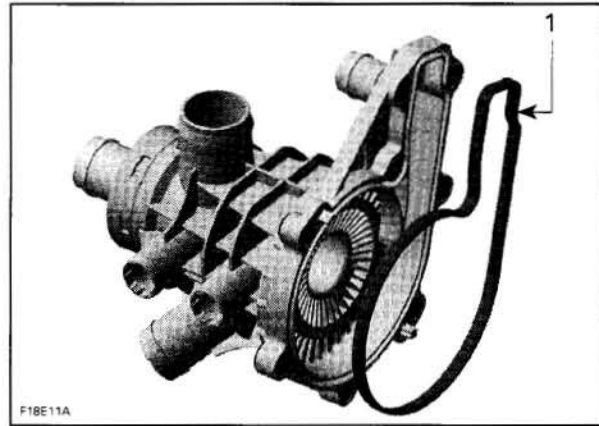

1. Water pump housing gasket

Check if thermostat is in good condition. Refer to *THERMOSTAT* elsewhere in this section.

#### Installation

The installation is the opposite of the removal procedure. Install screws as per the following illustration.

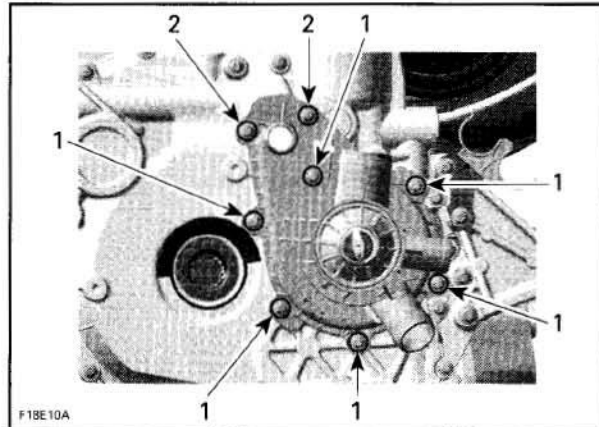

1. Screws M6 x 25  
2. Screws M6 x 105

**CAUTION:** To prevent leaking, take care that the gaskets are exactly in groove when you re-install the water pump housing.

Apply Loctite 243 (P/N 290 897 651) on screw threads and torque to 10 N•m (89 lbf•in).

Tightening sequence for screws on water pump housing is as per following illustration.

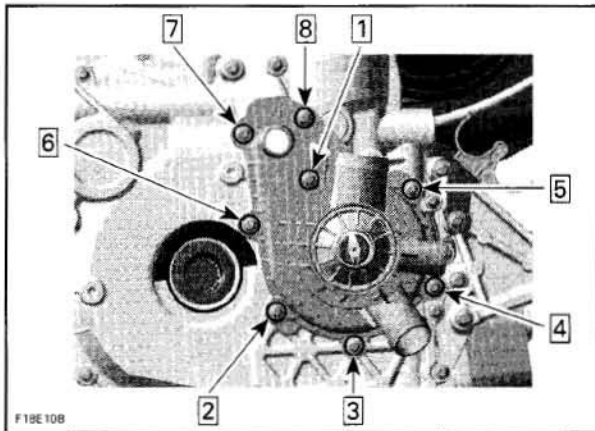

## WATER PUMP IMPELLER

### Removal

Remove:

- water pump housing no. 6 as described in this section
- unscrew the impeller no. 8 clockwise.

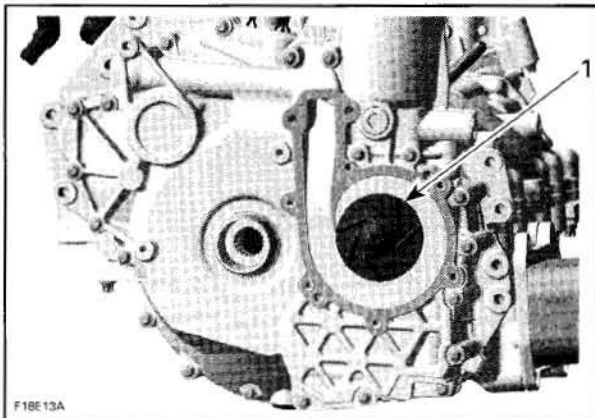

1. Impeller

**CAUTION:** Coolant/oil pump shaft no. 9 and impeller no. 8 have left-hand threads. Remove by turning clockwise and install by turning counterclockwise.

### Inspection

Check impeller for cracks or other damage. Replace impeller if damaged.

### Installation

The installation is the opposite of the removal procedure. Pay attention to the following details.

**CAUTION:** Be careful not to damage impeller wings during installation.

Torque impeller to 3 N•m (26 lbf•in).

## THERMOSTAT

The thermostat is a single action type.

### Removal

Remove the water pump housing from the PTO cover. Refer to *WATER PUMP HOUSING* above in this section.

**NOTE:** The thermostat is located inside the water pump housing.

### Leak Test

Plug the connections of the oil cooler return hose, coolant tank hose, ride plate return hose and cylinder head return hose with a rag.

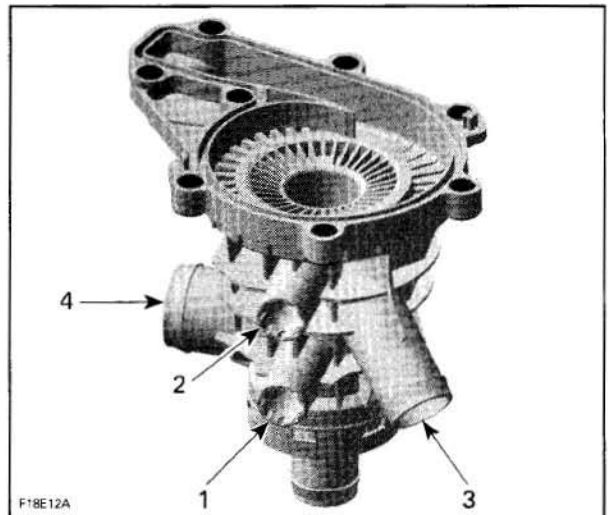

1. Oil cooler return connection
2. Coolant tank hose connection
3. Ride plate return hose connection
4. Cylinder head return hose connection

Fill the water pump housing with water.

If a bigger quantity of coolant leaks out at the ride plate outlet connection, replace the water pump housing. Refer to *WATER PUMP HOUSING* in this section.

If there is no leak, check the operation of the thermostat.

### Dynamic Test

To check the operation of the thermostat, put it in water and heat water. Look inside the cylinder head return hose connection to see the movement of the thermostat. Thermostat should open when water temperature reaches 87°C (188°F).

If there is no operation, replace the water pump housing.



## Section 03 ENGINE

### Subsection 09 (COOLING SYSTEM)

#### Installation

For installation, reverse the removal procedure, paying attention to the following details.

Refer to *WATER PUMP HOUSING* in this section.

#### ROTARY SEAL

##### Inspection

Check weep hole for oil or coolant leak.

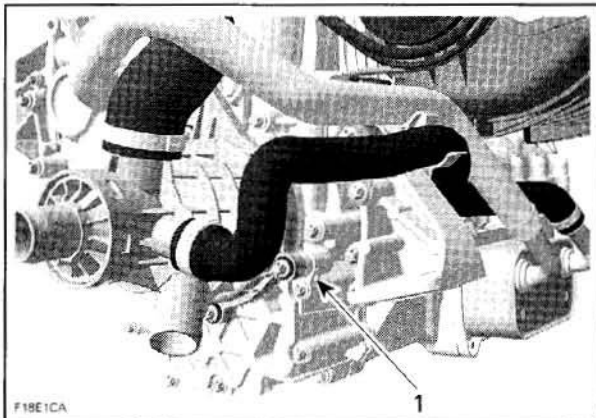

1. Weep hole

Coolant leaking out of the hole indicates a defective rotary seal. Leaking oil indicates a faulty oil seal.

However, if seal is disassembled both parts have to be replaced together.

##### Removal

Remove:

- water pump housing no. 6

**CAUTION:** Always unscrew the impeller clockwise otherwise you can damage the components.

- unscrew the impeller no. 8 clockwise
- remove PTO cover no. 10 (refer to *PTO HOUSING/MAGNETO* section)
- remove screws no. 11 retaining oil pump cover

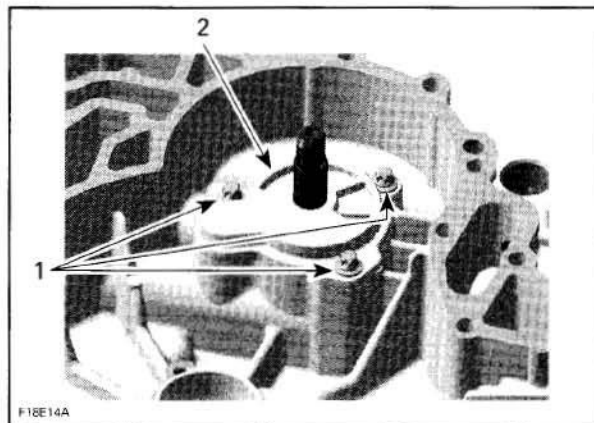

1. Retaining screws  
2. Oil pump cover

- remove oil pump cover no. 12
- remove outer oil pump rotor no. 13

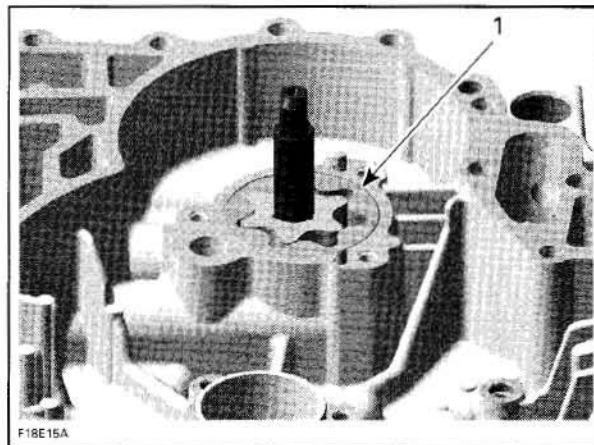

1. Outer oil pump rotor

- extract the coolant/oil pump shaft no. 9 from outside PTO housing cover with a pusher



**Section 03 ENGINE**  
**Subsection 09 (COOLING SYSTEM)**

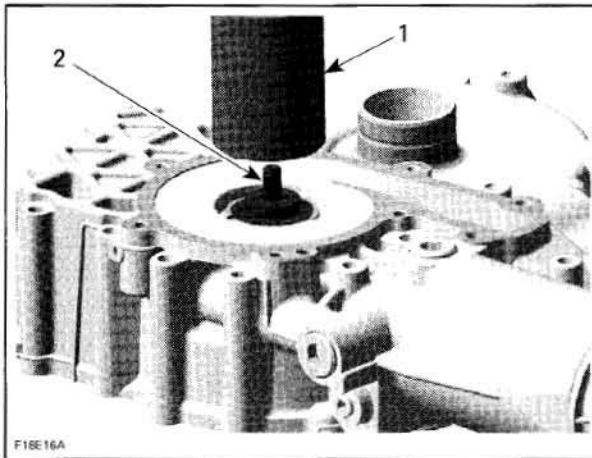

1. Pusher  
 2. Coolant/oil pump shaft

– remove rotary seal no. 14 with a screwdriver

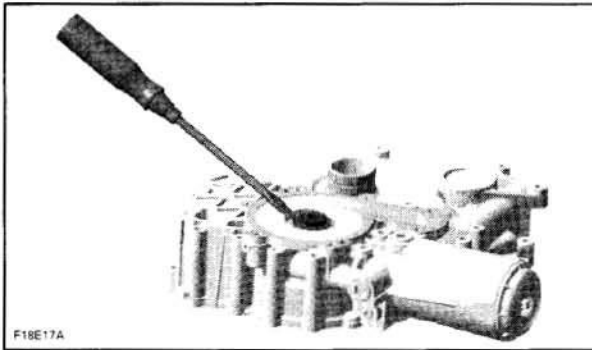

**CAUTION:** Be careful not to damage the surface of the rotary seal bore in magneto housing cover.

– always replace also the oil seal no. 15 behind the rotary seal.

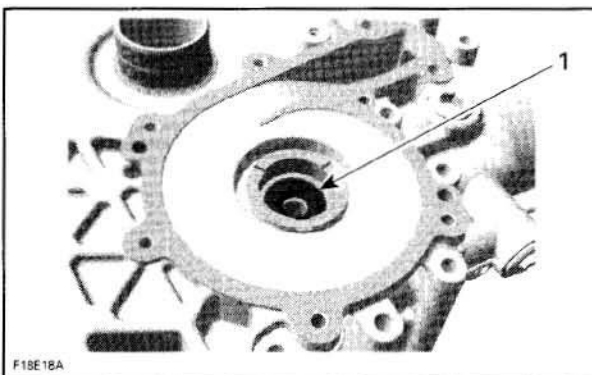

1. Oil seal

**Installation**

The installation is the opposite of the removal procedure. Pay attention to the following details.

**NOTE:** Never use oil in the press fit area of the oil seal and rotary seal.

Push water pump shaft oil seal in place by using thumb.

Install the new rotary seal using the rotary seal installer (P/N 529 035 823).

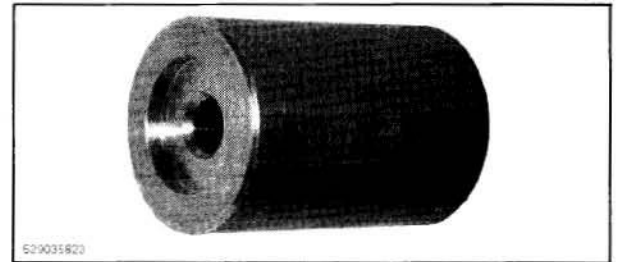

**CAUTION:** Never use a hammer for the rotary seal or water/oil pump shaft installation. Only use a press to avoid damaging the ceramic component.

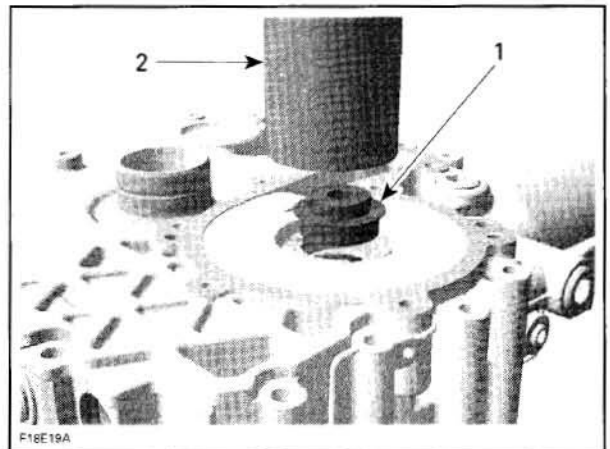

1. Rotary seal  
 2. Rotary seal installer

Install the coolant/oil pump shaft using the rotary seal installer (P/N 529 035 823) on the opposite side to the rotary seal and the oil seal protector (P/N 529 035 822) with a press.

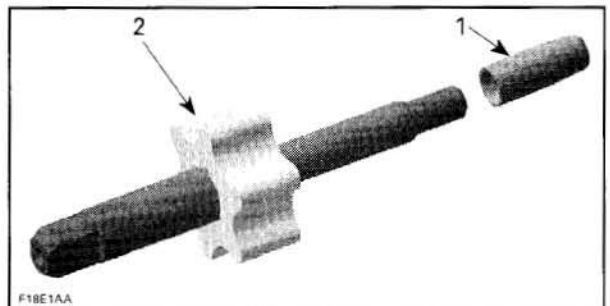

1. Oil seal protector  
 2. Coolant/oil pump shaft

## Section 03 ENGINE

### Subsection 09 (COOLING SYSTEM)

---

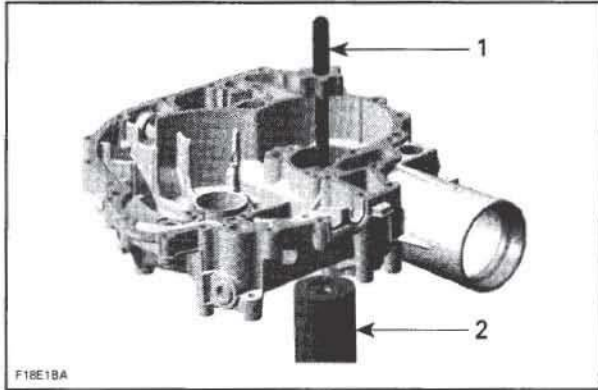

- F18E18A
1. Coolant/oil pump shaft with oil seal protector
  2. Rotary seal installer

# CYLINDER HEAD

## SERVICE TOOLS

<b>Description</b>	<b>Part Number</b>	<b>Page</b>
camshaft locking tool.....	529 035 839 .....	130-131
valve spring compressor clamp.....	529 035 724 .....	135
valve spring compressor cup.....	529 035 725 .....	135

## SERVICE PRODUCTS

<b>Description</b>	<b>Part Number</b>	<b>Page</b>
Clueber Isoflex grease.....	293 550 021 .....	135
Loctite 243 (blue).....	293 800 060 .....	127
Molykote G-N paste.....	413 703 700 .....	139



**Section 03 ENGINE**  
**Subsection 10 (CYLINDER HEAD)**

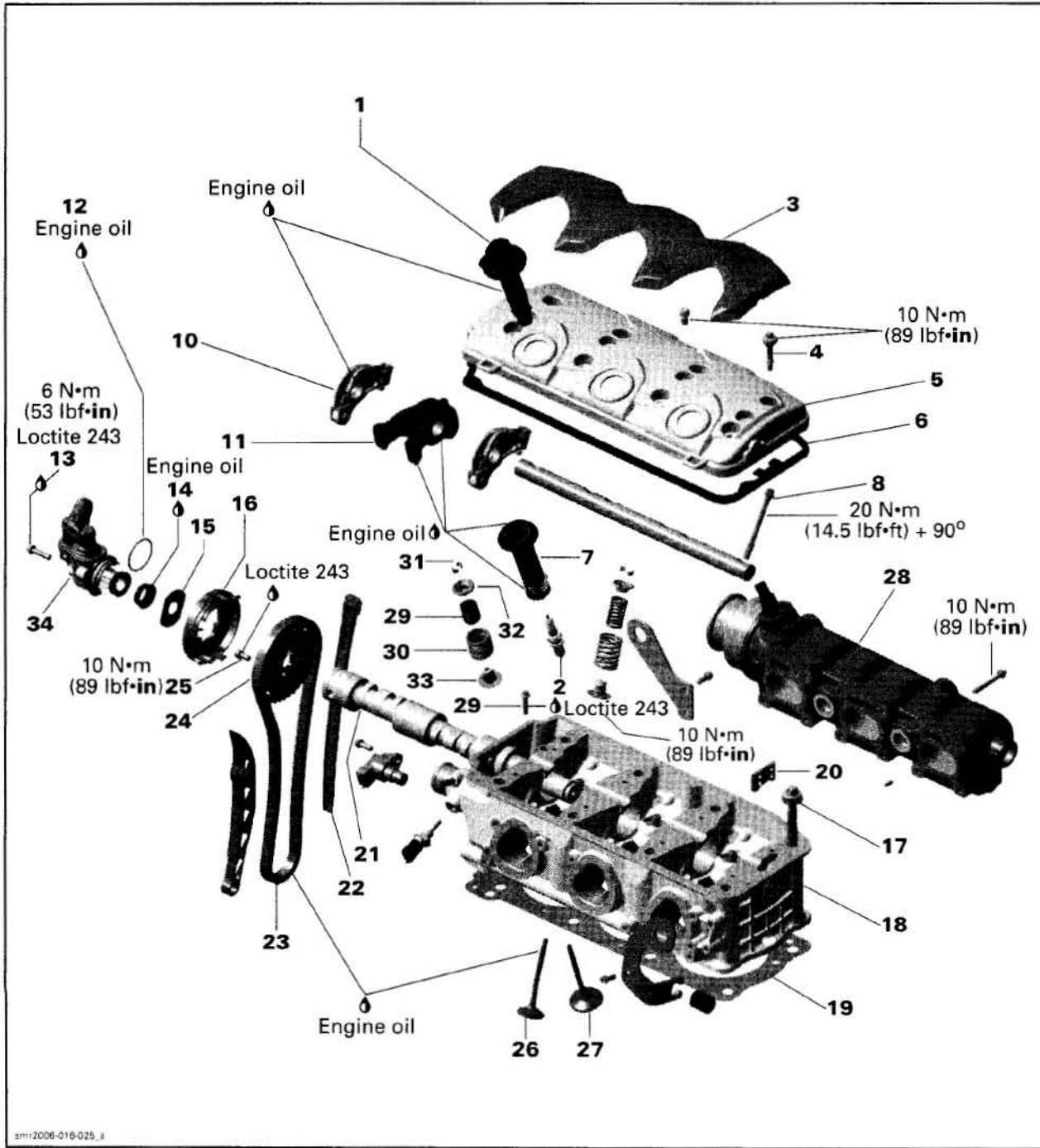

## GENERAL

**NOTE:** When diagnosing an engine problem, always perform an engine leak test. This will help pin-point a problem. Refer to *ENGINE LEAK TEST* section for procedures.

Always place the vehicle on level surface.

Always disconnect the negative wire from the battery before working on the engine.

Even if the removal of many parts is not necessary to reach another part, it is recommended to remove these parts in order to check them.

For installation, use the torque values and Loctite products as mentioned. Clean threads before using Loctite product when installing screws.

When disassembling parts that are duplicated in the engine, (e.g.: valves, bushings), it is strongly recommended to note their position (cylinder 1, 2 or 3) and to keep them as a "group". If you find a defective component, it would be much easier to find the cause of the failure within the group of parts (e.g.: you found a worn valve guide. A bent spring could be the cause and it would be easy to know which one among the springs is the cause to replace it if you grouped them at disassembly). Besides, since used parts have matched together during the engine operation, they will keep their matched fit when you reassemble them together within their "group".

## PROCEDURES

### EXHAUST MANIFOLD

#### Removal

Refer to *EXHAUST SYSTEM* to remove exhaust pipe and cooling hoses.

Unscrew the exhaust manifold **no. 28** beginning with the bottom screws. This will help holding the manifold while you remove the screws.

Remove exhaust manifold.

#### Inspection

Inspect exhaust manifold condition paying attention for cracks or other damage. Check contact surfaces and hose. Replace any defective part.

Inspect plane surfaces for warpage. Small deformation can be corrected by grinding surface with a fine sand paper. Install sand paper on a surface plate and rub part against oiled sand paper.

## Installation

**NOTE:** There is no gasket between cylinder block and exhaust manifold.

Apply Loctite 243 (blue) (P/N 293 800 060) on threads of screws.

Torque screws to 10 N•m (89 lbf•in) as per following illustrated sequence.

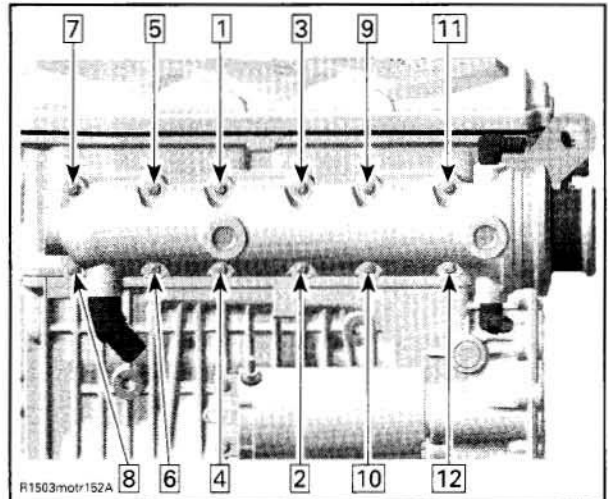

## VALVE COVER

### Removal

Remove:

- ignition coils **no. 1**
- valve cover cowl **no. 3**
- valve cover screws **no. 4**

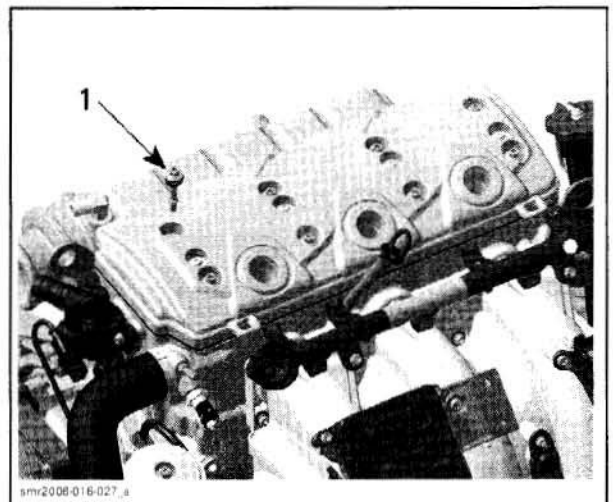

1. Valve cover screws



## Section 03 ENGINE

### Subsection 10 (CYLINDER HEAD)

- valve cover no. 5 and gasket no. 6.

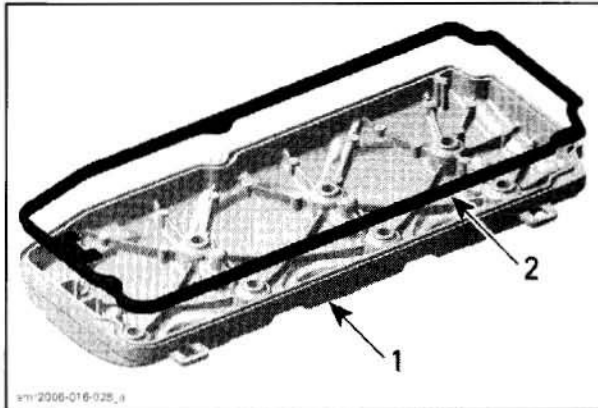

1. Valve cover  
2. Gasket

### Inspection

Check if the gasket on the valve cover and the rubber bushing on the valve cover screws are brittle, cracked or hard. If so, replace the gasket or the valve cover screw accordingly.

### Installation

For installation, reverse the removal procedure.

**NOTE:** Install the valve cover screws according to following sequence.

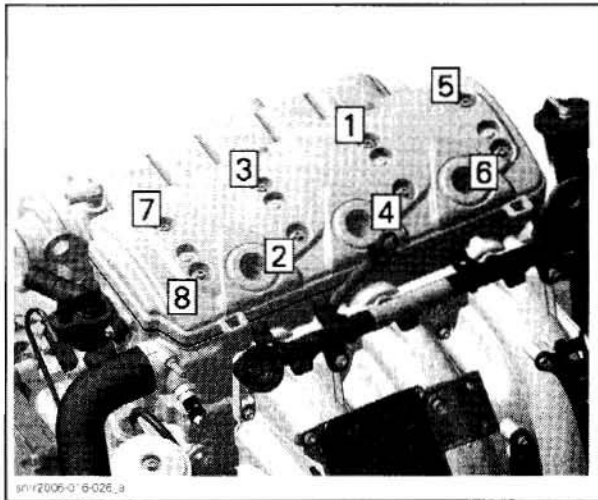

Torque screws to 10 N•m (89 lbf•in).

## ROCKER ARM

### Removal

Lock crankshaft, refer to *CYLINDER BLOCK* section.

Remove:

- ignition coils no. 1

- spark plugs
- valve cover no. 5
- spark plug tube no. 7

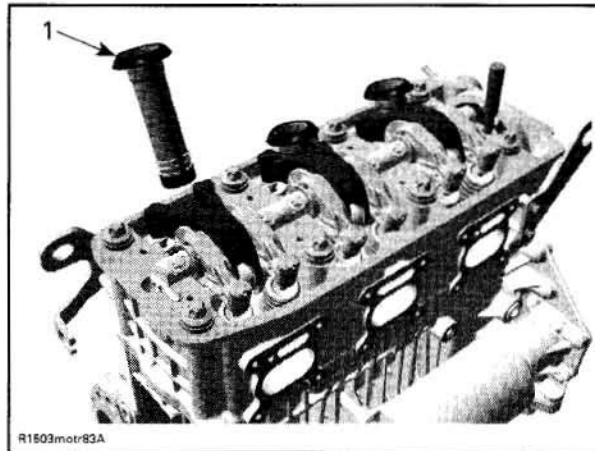

1. Spark plug tube

- rocker arm shaft screws no. 8. Discard screws

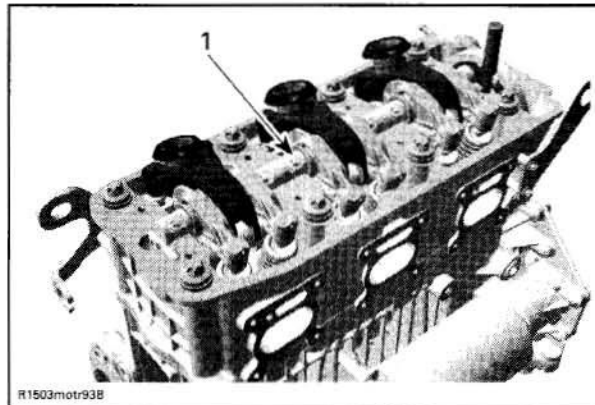

1. Rocker arm shaft screws

- rocker arm shaft no. 9 with rocker arm assembly (exhaust side no. 10 and intake side no. 11).

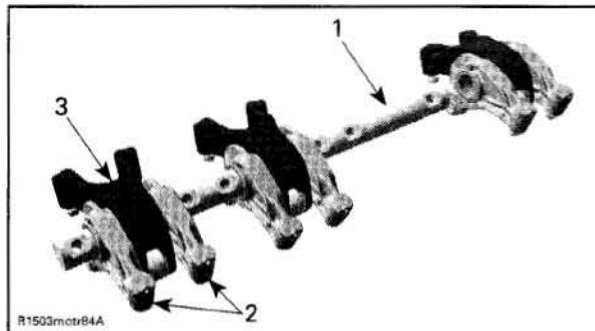

1. Rocker arm shaft  
2. Rocker arms (exhaust side)  
3. Rocker arm (intake side)



**Section 03 ENGINE**  
Subsection 10 (CYLINDER HEAD)

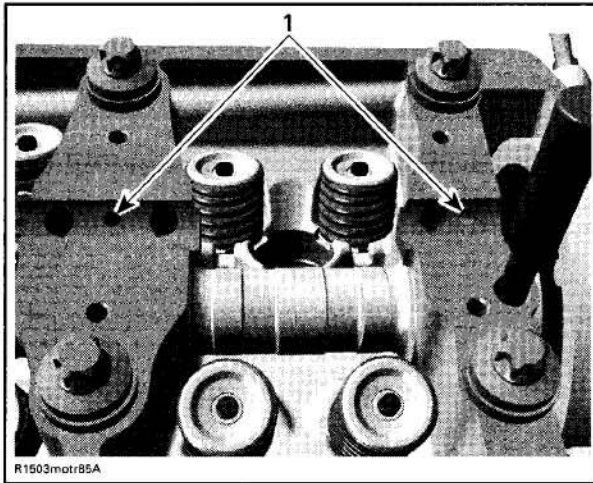

1. Oil supply from the camshaft to the rocker arm shaft, then to the rocker arms and finally to the valve adjustment

**Inspection**

**Spark Plug Tube**

Check seals on spark plug tube. If seals are brittle, cracked or hard, replace spark plug tube.

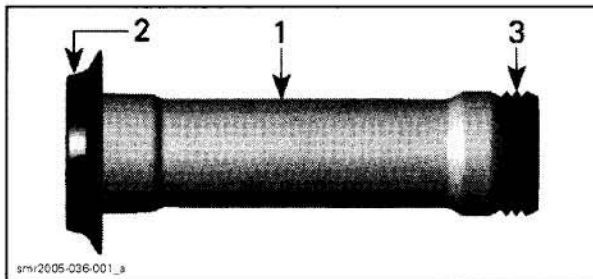

**TYPICAL**  
1. Spark plug tube  
2. Seal to the valve cover  
3. Seal to the cylinder head

**Rocker Arm**

Inspect each rocker arm for cracks and scored friction surfaces. If so, replace rocker arm assembly.

Check the rocker arm rollers for free movement, wear and excessive radial play. Replace rocker arm assembly as necessary.

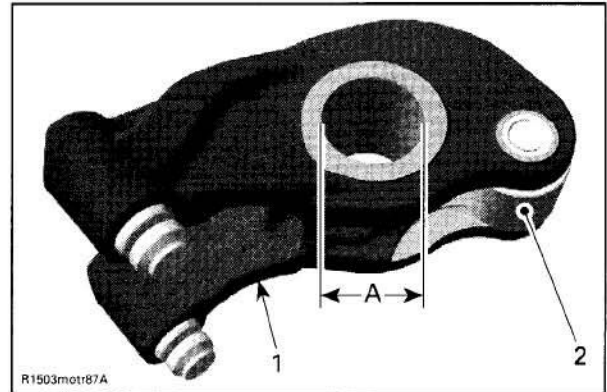

1. Rocker arm (intake side)  
2. Roller  
A. Bore for rocker arm shaft

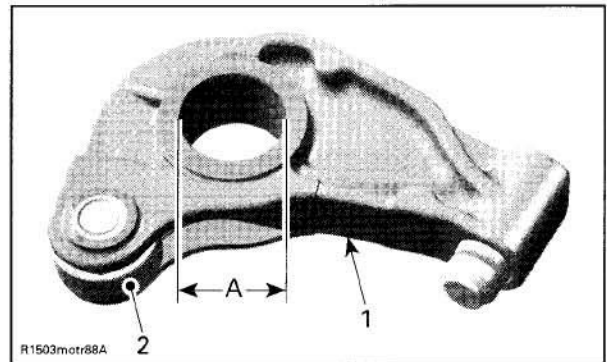

1. Rocker arm (exhaust side)  
2. Roller  
A. Bore for rocker arm shaft

Measure rocker arm bore diameter. If diameter is out of specification, change the rocker arm assembly.

ROCKER ARM BORE DIAMETER	
NEW MINIMUM	20.007 mm (.7877 in)
NEW MAXIMUM	20.020 mm (.7881 in)
SERVICE LIMIT	20.035 mm (.7887 in)

Press the hydraulic lifter with your thumb. If the hydraulic lifter groove disappears inside rocker arm casting, replace rocker arm assembly. Lifter must turn freely in rocker arm bore. Otherwise, replace.

## Section 03 ENGINE

### Subsection 10 (CYLINDER HEAD)

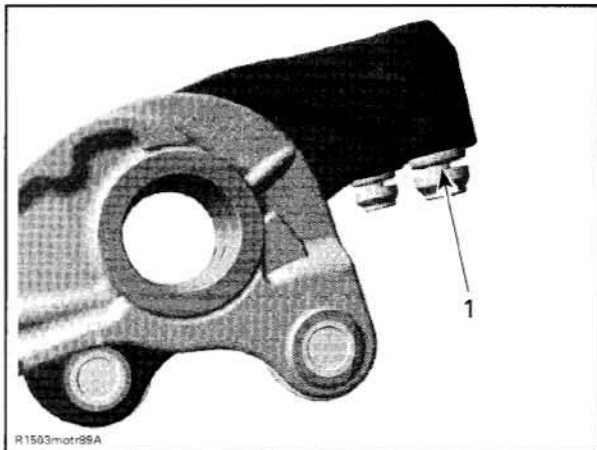

1. Hydraulic lifter groove

#### Rocker Arm Shaft

Check for scored friction surfaces, if so, replace parts.

Measure rocker arm shaft diameter.

ROCKER ARM SHAFT DIAMETER	
NEW MINIMUM	19.980 mm (.7866 in)
NEW MAXIMUM	19.993 mm (.7871 in)
SERVICE LIMIT	19.965 mm (.7860 in)

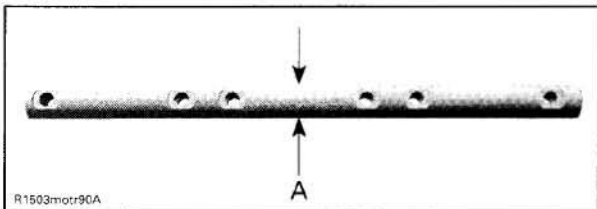

A. Measure rocker arm shaft diameter here

Any area worn excessively will require parts replacement.

#### Installation

For installation, reverse the removal procedure. Pay attention to the following details.

Apply engine oil on rocker arm shaft.

**IMPORTANT:** The rocker arm shaft can only be installed in one specific position. Therefore crankshaft as well as camshaft has to be positioned with their locking pins when the piston of cylinder no. 3 is on ignition TDC. Refer to *CYLINDER BLOCK* section for crankshaft and the following for the camshaft locking.

**NOTE:** Cylinder no. 3 is next to the oil filler tube.

Use camshaft locking tool (P/N 529 035 839). Rotate camshaft so that tool can be pushed in camshaft hole and lock camshaft in place.

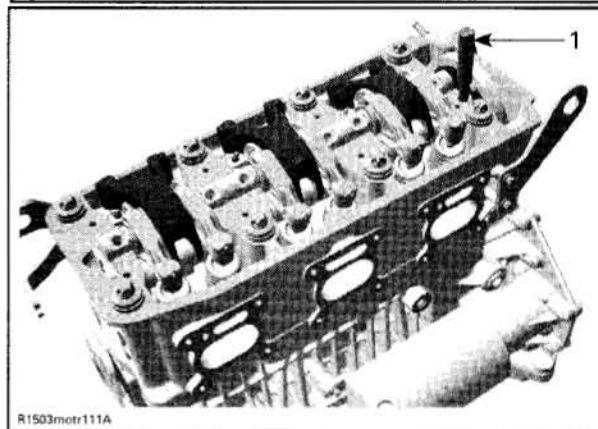
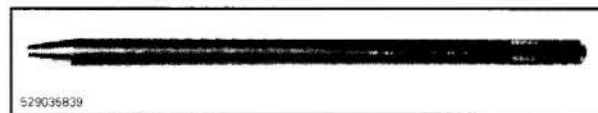

1. Camshaft locking tool

Then, the camshaft sprocket lines should be lined up as shown in the following illustration.

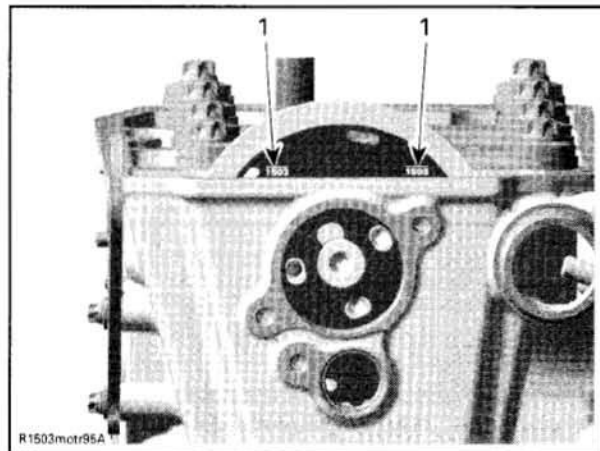

1. Position lines

Position the rocker arm shaft with the notches on top.



**Section 03 ENGINE**  
Subsection 10 (CYLINDER HEAD)

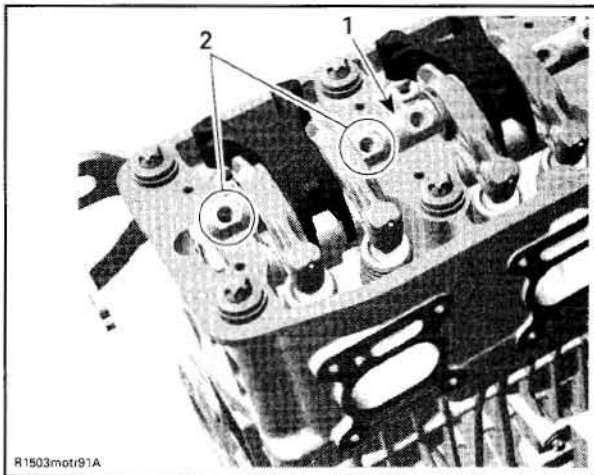

1. Rocker arm shaft  
2. Rocker arm shaft notches

Install NEW rocker arm shaft screws no. 8. Torque as per following procedure:

**CAUTION:** This assembly uses stretch screws. As the screws have been stretched from the previous installation, it is very important to use new screws at assembly. Failure to replace screws and to strictly follow the torque procedure may cause screws to loosen and lead to engine damage.

- Torque screws at first to 10 N•m (89 lbf•in) according to following sequence.

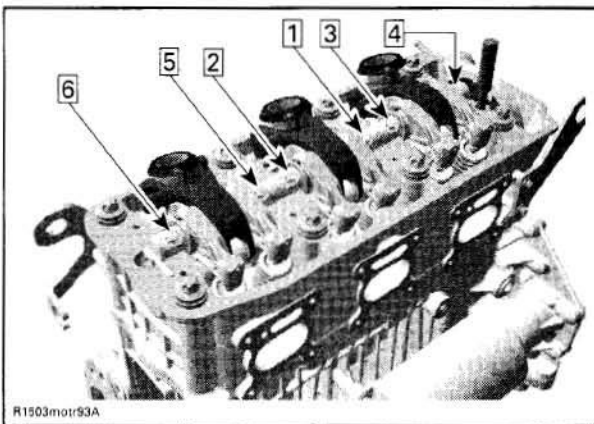

- Torque screws to 20 N•m (177 lbf•in).
- Finish tightening screws turning an additional 90° rotation with a torque angle gauge.

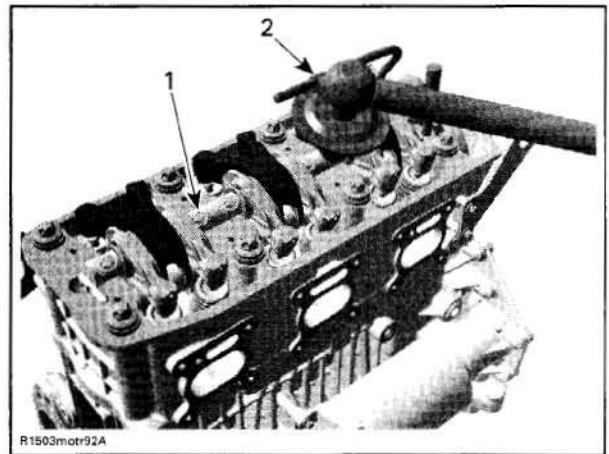

1. Rocker arm shaft screw  
2. Torque angle gauge

### CAMSHAFT TIMING GEAR

**NOTE:** Although it is not necessary to position crankshaft to TDC for disassembly, it is a good practice to do it, as a troubleshooting step, to know before disassembly if valve timing was appropriate.

#### Removal

Lock crankshaft, refer to *CYLINDER BLOCK* section.

Remove:

- valve cover no. 5
- chain guide no. 22
- Allen screws no. 25
- camshaft timing gear no. 24.

**NOTE:** Secure timing chain no. 23 with a retaining wire.

#### Inspection

Check camshaft timing gear for wear or deterioration.

If gear is worn or damaged, replace it as a set (camshaft timing gear and timing chain).

For crankshaft timing gear, refer to *CYLINDER BLOCK* section.

#### Installation

For installation, reverse the removal procedure. Pay attention to the following details.

Using the camshaft locking tool (P/N 529 035 839), lock camshaft on TDC position.





## Section 03 ENGINE

### Subsection 10 (CYLINDER HEAD)

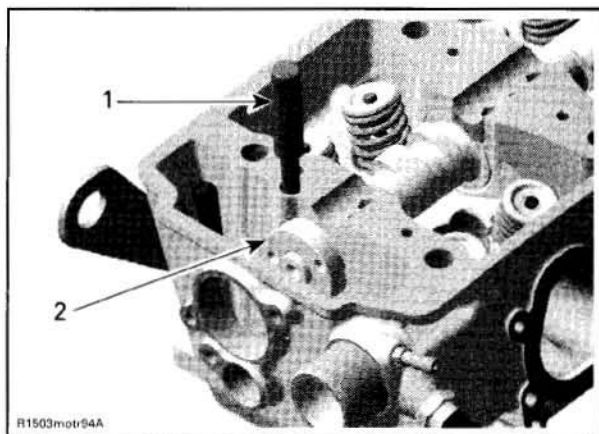

1. Camshaft locking tool  
2. Camshaft on TDC position

Install the camshaft timing gear with the writing visible, i.e. to be able to see the position lines when looking from outside of engine.

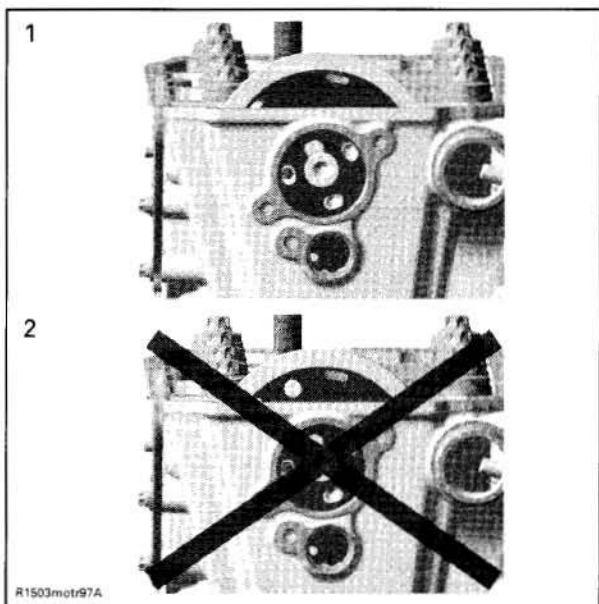

1. Good (with 1503 aligned)  
2. Never

Install timing chain. Refer to *CYLINDER BLOCK* section.

Ensure chain guides are in place.

Loosely install screws.

Install chain tensioner.

**NOTE:** There can be 2 different positions to install the timing gear on the camshaft. Basically both positions are working well, since the camshaft and crankshaft are locked in their proper position. Due to some tolerances, there could be one position which fits better than the other one. To check this, perform the following test.

Check if screws are still loose. If screws are squeezed by the timing gear, remove the chain tensioner again and rotate timing gear by one tooth clockwise. Then install the chain tensioner again.

Tighten screws and torque to 10 N•m (89 lbf•in).

Remove locking tools.

**CAUTION:** Crankshaft and camshaft must be locked on TDC position to place camshaft timing gear and timing chain in the proper position. To double check, take a look at the timing gear lines. They must be parallel to the cylinder head surface.

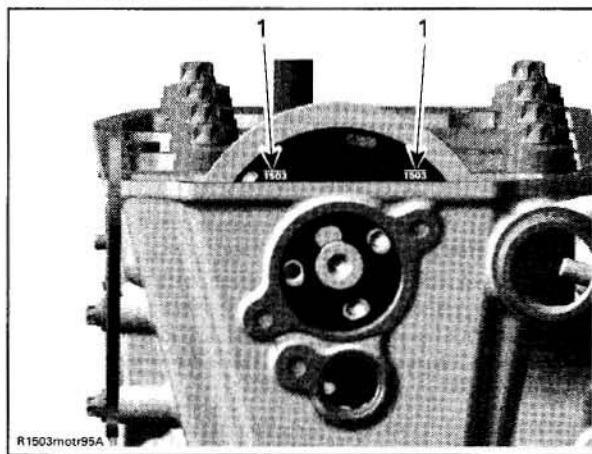

1. Position lines

**CAUTION:** Ensure to remove locking tools when finished.

## TIMING CHAIN

Refer to *CYLINDER BLOCK* section.

## CYLINDER HEAD

### Removal

Lock crankshaft, refer to *CYLINDER BLOCK* section.

Drain coolant (refer to *COOLING SYSTEM*).

Disconnect coolant temperature and camshaft position sensors (CTS and CAPS).

Remove:

- exhaust manifold (refer to *EXHAUST MANIFOLD* in this section)
- engine hoses

**Section 03 ENGINE**  
Subsection 10 (CYLINDER HEAD)

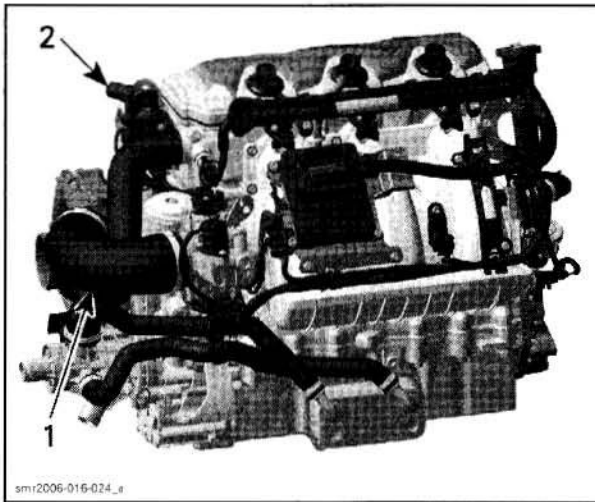

**TYPICAL**  
1. Coolant hose  
2. TOPS ventilation hose

- chain tensioner (refer to *CYLINDER BLOCK* section)
- valve cover
- camshaft timing gear
- cylinder head screws M6 no. 29

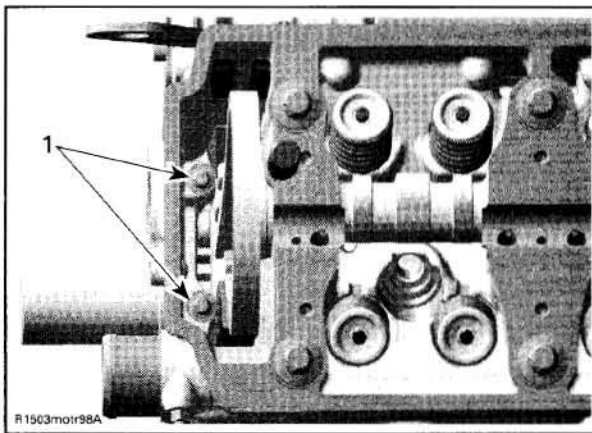

1. Cylinder head screws M6

- cylinder head screws M11 no. 17 retaining cylinder head to cylinder block.

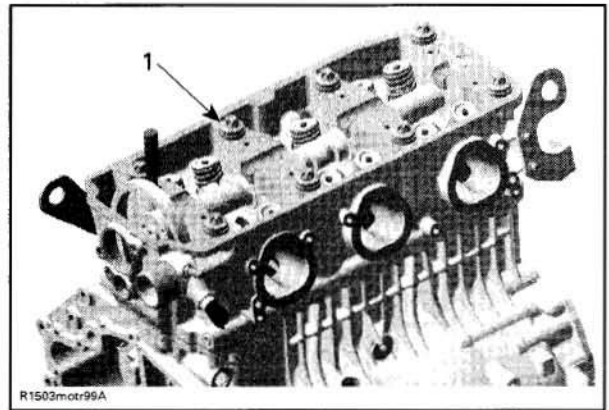

1. Cylinder head screws M11

Pull up cylinder head no. 18.

Remove gasket no. 19.

**Cleaning**

Remove carbon deposits from combustion chamber, exhaust port and piston top.

**Inspection**

Check for cracks between valve seats and warpage of cylinder head, if so, replace cylinder head.

Check mating surface between cylinder and cylinder head for contamination. If so, clean both surfaces.

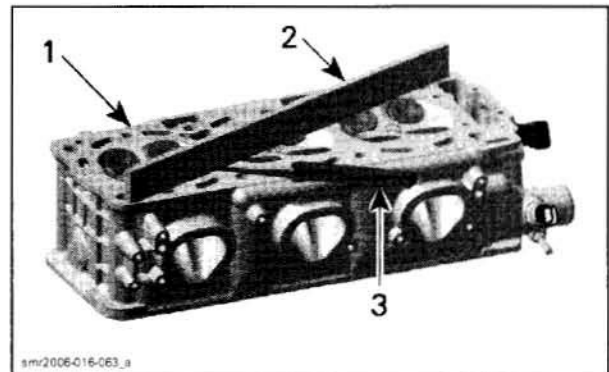

1. Cylinder head  
2. Flat bar  
3. Feeler gauge

If warpage of cylinder head is more than 0.15 mm (.006 in) replace cylinder head.

**Installation**

For installation, reverse the removal procedure. Pay attention to the following details.

Ensure dowel pins are in place.

Install new cylinder head gasket.



## Section 03 ENGINE

### Subsection 10 (CYLINDER HEAD)

**CAUTION:** Each installation of the cylinder head requires a new cylinder head gasket. Using a gasket twice will cause engine damage, even if the engine had not run.

Install cylinder screws M11 no. 17. Torque screws as per following procedure.

**CAUTION:** This assembly uses stretch screws. As the screws have been stretched from the previous installation, it is very important to measure each screw at assembly. If screw is out of specification, replace by a new. Failure to replace screws and to strictly follow the torque procedure may cause screws to loosen and lead to engine damage.

#### CYLINDER SCREW M11

SERVICE LIMIT	148.5 mm (5.846 in)
---------------	---------------------

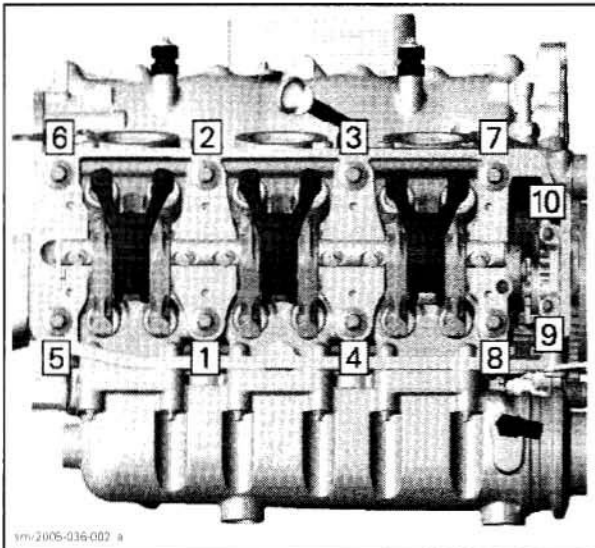

**NOTE:** Torque screws no. 29 after the tightening of the cylinder head screws is finished.

Torque screws according to following sequence.

First torque to 40 N•m (30 lbf•ft).

Then tighten screws turning an additional 120° rotation with a torque angle gauge and finish tightening with a 90° rotation. Torque screws no. 29 to 10 N•m (89 lbf•in).

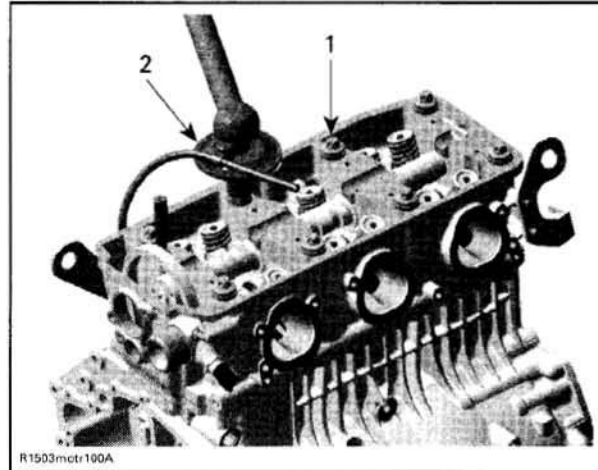

1. Cylinder screws M11  
2. Angle torque wrench

Remove crankshaft locking tool then install plug with sealing ring.

## CAMSHAFT

### Removal

Remove:

- valve cover
- rocker arms
- chain tensioner (refer to *CYLINDER BLOCK* section)
- camshaft timing gear
- camshaft lock no. 20
- camshaft no. 21.

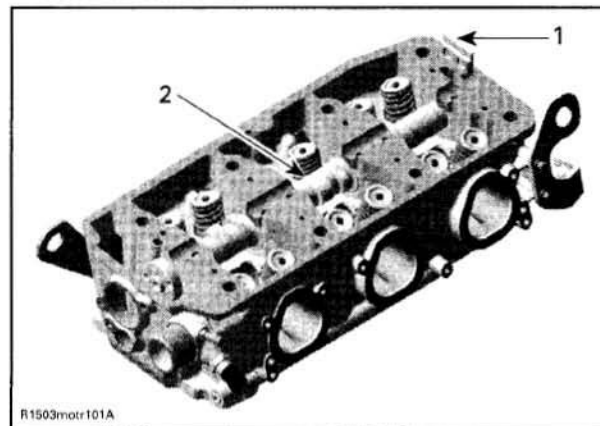

1. Camshaft lock  
2. Camshaft

### Inspection

Check each lobe and bearing journal of camshaft for scoring, scuffing, cracks or other signs of wear.

Measure camshaft bearing journal diameter and lobe height using a micrometer.



**Section 03 ENGINE**  
Subsection 10 (CYLINDER HEAD)

Measure clearance between both ends of camshaft and cylinder head.

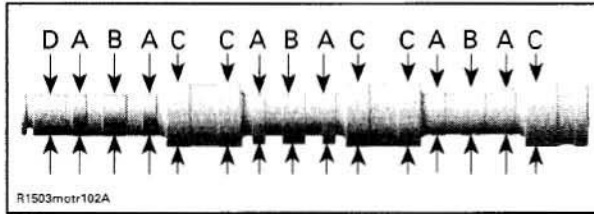

- A. Camshaft lobe (exhaust valves)  
B. Camshaft lobe (intake valves)  
C. Camshaft bearing journal  
D. Camshaft bearing journal — engine front

CAMSHAFT LOBE — EXHAUST VALVE	
NEW MINIMUM	31.699 mm (1.248 in)
NEW MAXIMUM	31.809 mm (1.252 in)
SERVICE LIMIT	31.670 mm (1.247 in)
CAMSHAFT LOBE — INTAKE VALVE	
NEW MINIMUM	31.480 mm (1.239 in)
NEW MAXIMUM	31.590 mm (1.244 in)
SERVICE LIMIT	31.450 mm (1.238 in)
CAMSHAFT BEARING JOURNAL	
NEW MINIMUM	39.892 mm (1.5705 in)
NEW MAXIMUM	39.905 mm (1.5711 in)
SERVICE LIMIT	39.860 mm (1.5693 in)
CAMSHAFT BEARING JOURNAL — ENGINE FRONT	
NEW MINIMUM	24.939 mm (.9818 in)
NEW MAXIMUM	24.960 mm (.9826 in)
SERVICE LIMIT	24.910 mm (.9807 in)
CAMSHAFT BORE MEASURED IN DIAMETER	
NEW MINIMUM	40.000 mm (1.5748 in)
NEW MAXIMUM	40.016 mm (1.5754 in)
SERVICE LIMIT	40.050 mm (1.5767 in)
CAMSHAFT BORE — ENGINE FRONT MEASURED IN DIAMETER	
NEW MINIMUM	25.000 mm (.9842 in)
NEW MAXIMUM	25.013 mm (.9848 in)
SERVICE LIMIT	25.050 mm (.9862 in)

Replace parts that are not within specifications.

### Installation

For installation, reverse the removal procedure. Pay attention to the following details.

Grease the camshaft bearing journals well by using the Klueber Isoflex grease (P/N 293 550 021) or a similar product.

Install camshaft then place the camshaft lock no. 20 in the slot.

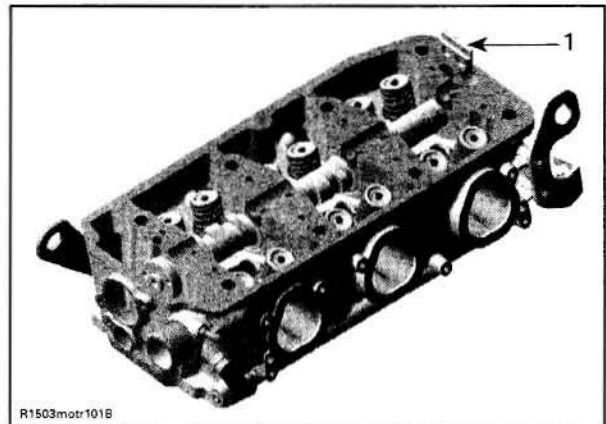

1. Camshaft lock position

For other parts, refer to proper installation procedure.

## VALVE SPRING

### Removal

Remove:

- rocker arms
- cylinder head.

Compress valve springs no. 29 and no. 30. Use valve spring compressor clamp (P/N 529 035 724) and valve spring compressor cup (P/N 529 035 725).

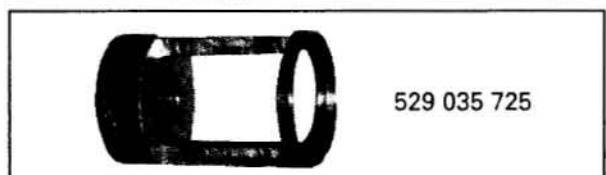
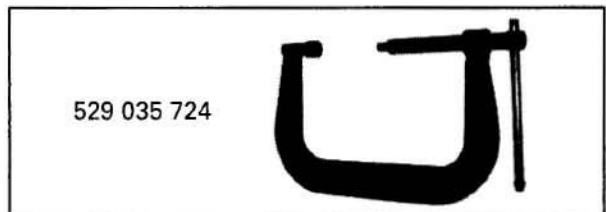

### **⚠ WARNING**

Always wear safety glasses when disassembling valve springs. Be careful when unlocking valves. Components could fly away because of the strong spring preload.

**Section 03 ENGINE**  
**Subsection 10 (CYLINDER HEAD)**

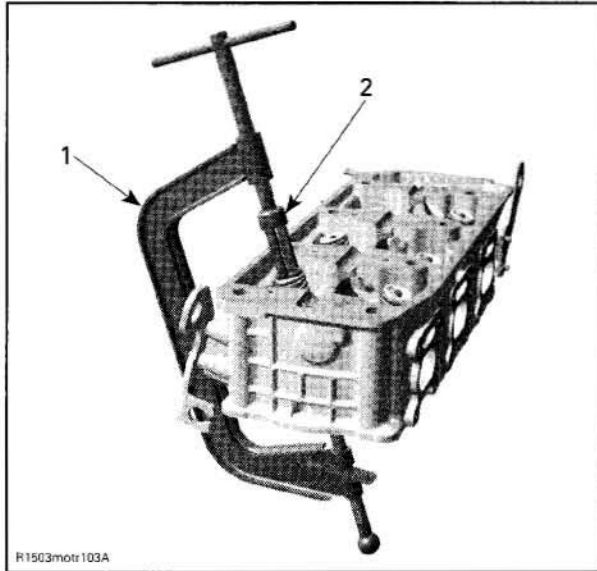

R1503motr103A

- 1. Valve spring compressor clamp
- 2. Valve spring compressor cup

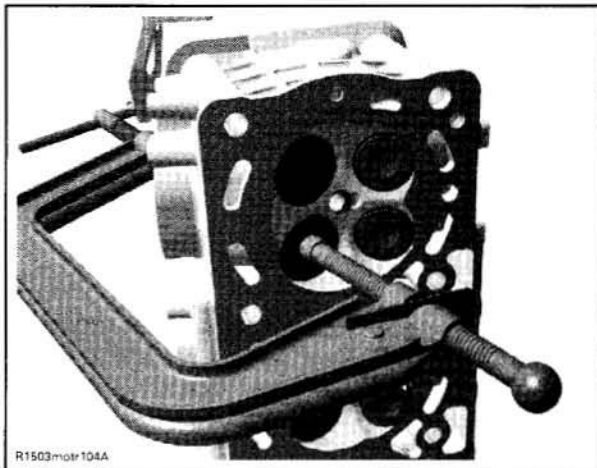

R1503motr104A

**LOCATE VALVE SPRING COMPRESSOR CLAMP IN CENTER OF THE VALVE**

Remove valve cotters no. 31.  
 Withdraw valve spring compressor, valve spring retainer no. 32 and valve springs.

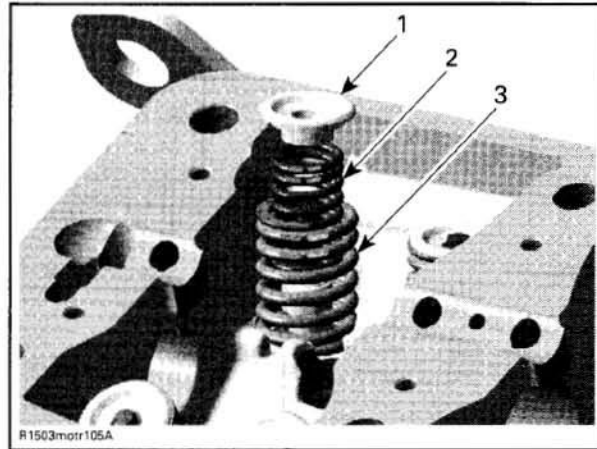

R1503motr105A

- 1. Valve spring retainer
- 2. Inner valve spring
- 3. Outer valve spring

**Inspection**

Check valve springs for rust, corrosion or other visible damages. If so, replace faulty valve springs.  
 Check valve springs for free length and straightness.

Replace valve springs if not within specifications.

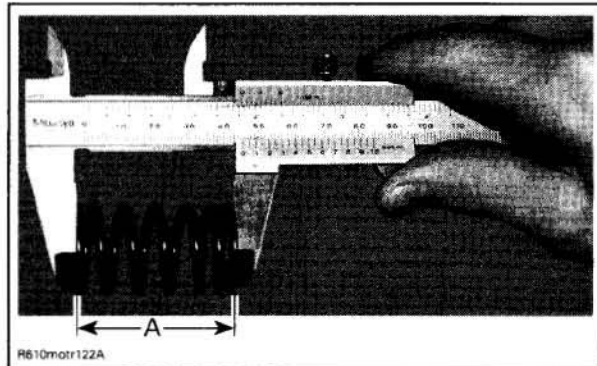

R610motr122A

A. Valve spring length

OUTER VALVE SPRING FREE LENGTH	
NEW NOMINAL	45.45 mm (1.789 in)
SERVICE LIMIT	43 mm (1.693 in)
INNER VALVE SPRING FREE LENGTH	
NEW NOMINAL	41.02 mm (1.615 in)
SERVICE LIMIT	38.8 mm (1.499 in)

**Installation**

For installation, reverse the removal procedure. Pay attention to the following details.

Colored area of the valve spring must be placed on top.



**NOTE:** Valve cotters must be properly engaged in valve stem grooves.

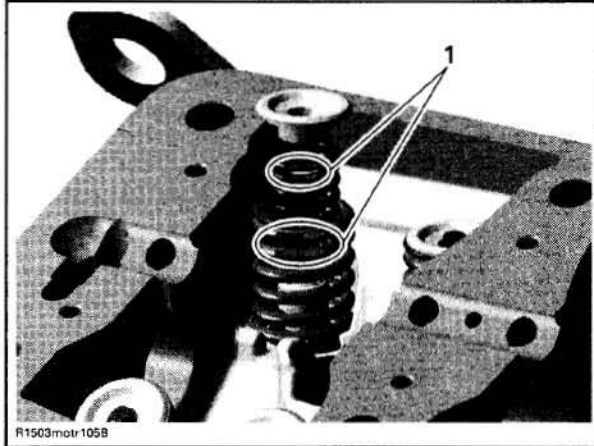

1. Position of the valve spring

## VALVE

### Removal

Remove valve spring.

Push valve stem then pull valves no. 26 and no. 27 out of valve guides.

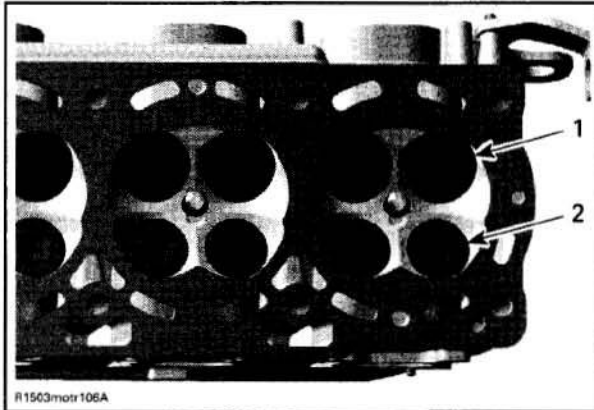

1. Intake valve 38 mm  
2. Exhaust valve 31 mm

Remove valve stem seal no. 33 with special pliers such as Snap-on YA 8230.

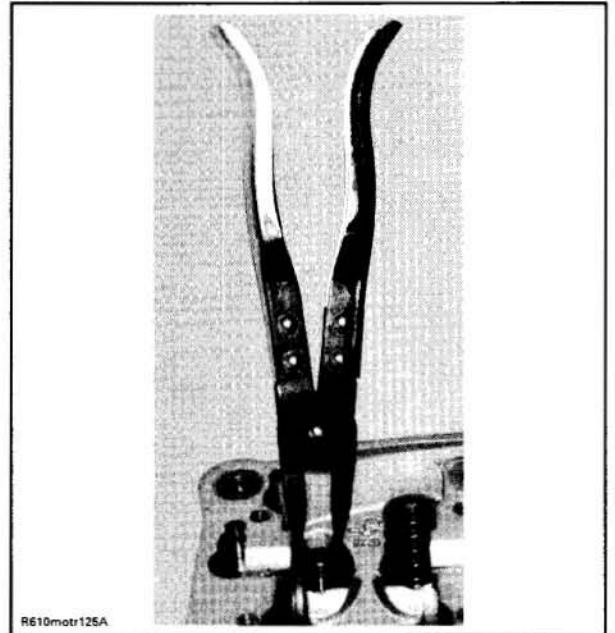

### Inspection

#### Valve Stem Seal

Inspection of valve stem seals is not needed because new seals should always be installed whenever cylinder head is removed.

#### Valve

Inspect valve surface, check for abnormal stem wear and bending. If so, replace by a new one.

#### Valve Stem and Valve Guide Clearance

Measure valve stem and valve guide in three places, using a micrometer and a small bore gauge.

**NOTE:** Clean valve guide to remove carbon deposits before measuring.

Change valve if valve stem is out of specification or has other damages such as wear or friction surface.



**Section 03 ENGINE**  
**Subsection 10 (CYLINDER HEAD)**

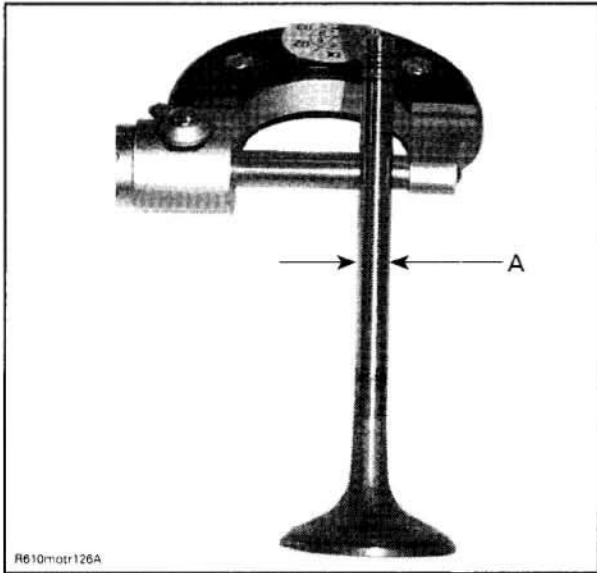

R610motr126A

A. Valve stem diameter

VALVE STEM DIAMETER	
NEW MINIMUM	
Exhaust	5.946 mm (.2341 in)
Intake	5.961 mm (.2347 in)
NEW MAXIMUM	
Exhaust	5.960 mm (.2346 in)
Intake	5.975 mm (.2352 in)
SERVICE LIMIT	
Exhaust	5.93 mm (.233 in)
Intake	

Replace valve guide if it is out of specification or has other damages such as wear or friction surface. Refer to valve guide replacement below.

VALVE GUIDE DIAMETER	
NEW MINIMUM	
Exhaust	5.994 mm (.2359 in)
Intake	
NEW MAXIMUM	
Exhaust	6.018 mm (.2369 in)
Intake	
SERVICE LIMIT	
Exhaust	6.060 mm (.2386 in)
Intake	

**Valve Guide Replacement**

**CAUTION:** Do not heat cylinder head for this procedure.

**CAUTION:** The sharp edge near the top of the valve guide must be machined away. Otherwise it will foul the valve guide hole in the cylinder head and destroy the cylinder head, as the valve guide is removed.

Use a special reamer as far as the top of the notch.

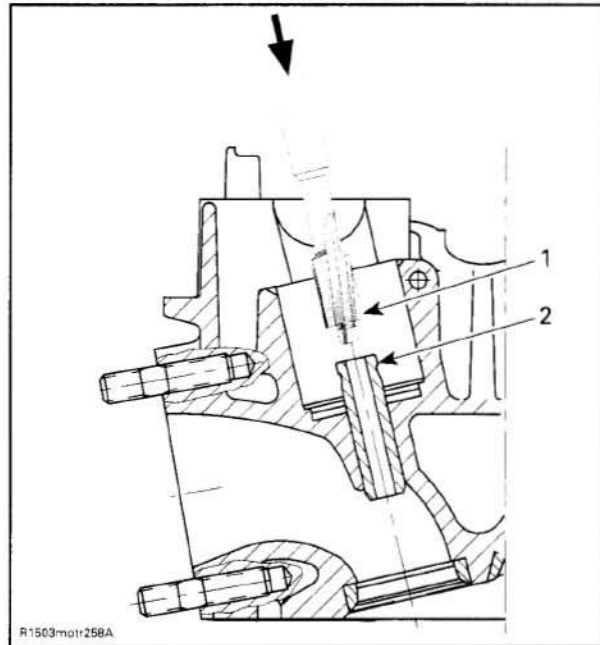

R1503motr258A

TYPICAL  
 1. Special reamer  
 2. Notch

Chase valve guide out of the cylinder head towards combustion chamber by using a suitable punch.

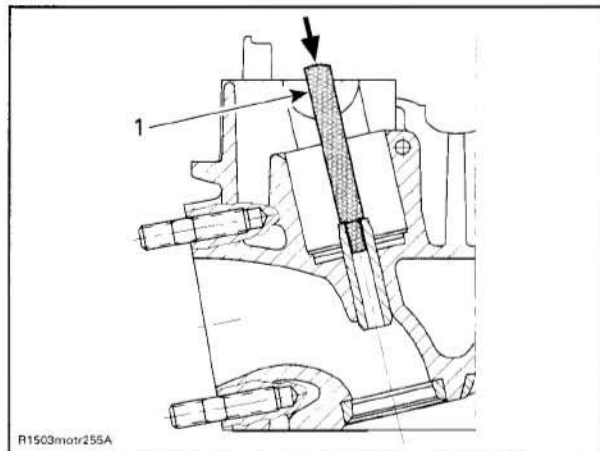

R1503motr255A

TYPICAL  
 1. Punch

**Section 03 ENGINE**  
**Subsection 10 (CYLINDER HEAD)**

Check valve guide bore for abraded material. The inlet and exhaust valve guides have the same length and are interchangeable.

**NOTE:** If valve guide has caused scoring during extraction, replace the cylinder head.

Grease the bore in cylinder head and the leading end of valve guide with Molykote G-N paste (P/N 413 703 700).

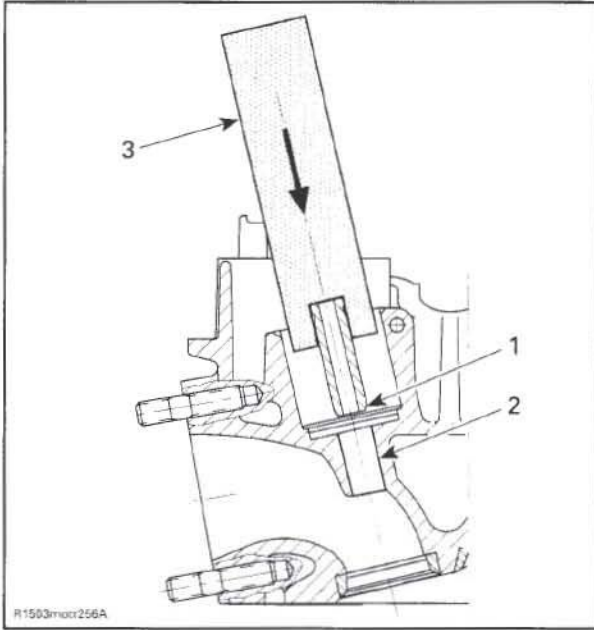

**TYPICAL**  
 1. Valve guide leading end  
 2. Cylinder head bore  
 3. Jig

With a suitable jig press the valve guide into the cold cylinder head as shown.

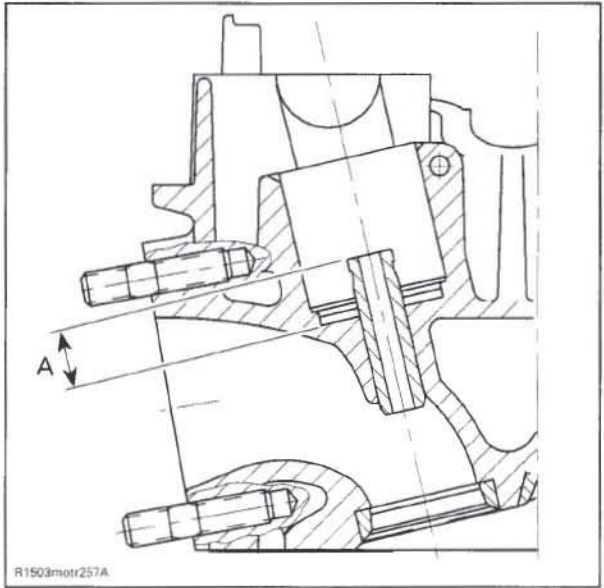

**TYPICAL**  
 A. Protrusion

VALVE GUIDE PROTRUSION	
MINIMUM	12.4 mm (.4882 in)
MAXIMUM	12.8 mm (.5039 in)

**NOTE:** For lubrication of the reamer use only cutting oil. Turn the reamer only forward, in cutting direction, never backward. Clean the reamer at short intervals from swarf, moving the reamer only while turning in cutting direction.

Ream the new valve guide with a reamer 6 mm diameter.

Clean cylinder head carefully. Check that the valve seat is concentric with the new guide axis (check contact surface with engineer's blue).

## Section 03 ENGINE

### Subsection 10 (CYLINDER HEAD)

#### Valve Face and Seat

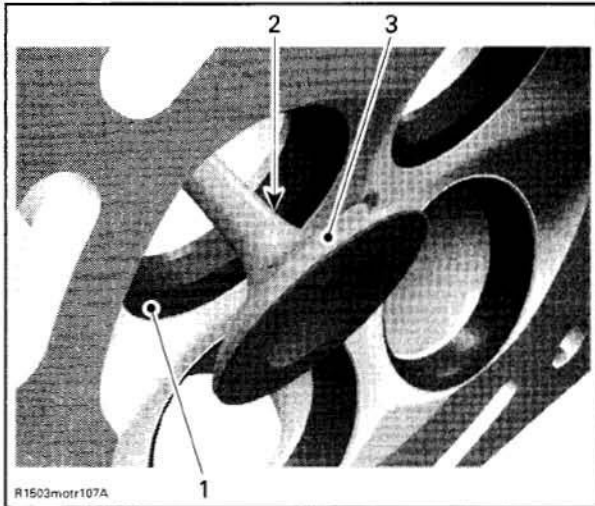

- 1 Valve seat
- 2 Exhaust valve contaminated area
- 3 Valve face (contact surface to valve seat)

Check valve face and seat for burning or pittings and replace valve or cylinder head if there are signs of damage.

Ensure to seat valves properly. Apply some lapping compound on valve face and work valve on its seat with a lapping tool.

Measure valve face contact width.

**NOTE:** The location of contact area should be in center of valve seat.

Measure valve seat width, using a caliper.

VALVE SEAT CONTACT WIDTH	
NEW	
Exhaust	1.25 to 1.55 mm (.049 to .061 in)
Intake	1.10 to 1.30 mm (.043 to .051 in)
SERVICE LIMIT	
Exhaust	2 mm (.078 in)
Intake	1.8 mm (.07 in)

If valve seat contact width is too wide or has dark spots, replace the cylinder head.

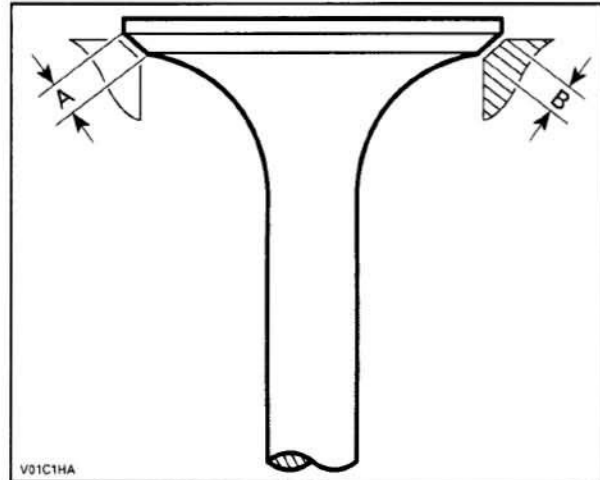

- A Valve face contact width
- B Valve seat contact width

#### Valve Seat Grinding

**NOTE:** The valve seats may be reground with a valve seat grinder which centers on the valve guide.

- Grind the valve seat at 45°. Remove no more material than absolutely necessary to clean the seat up.
- Using a 35° stone, narrow the valve seat until the appropriate outer diameter is obtained.

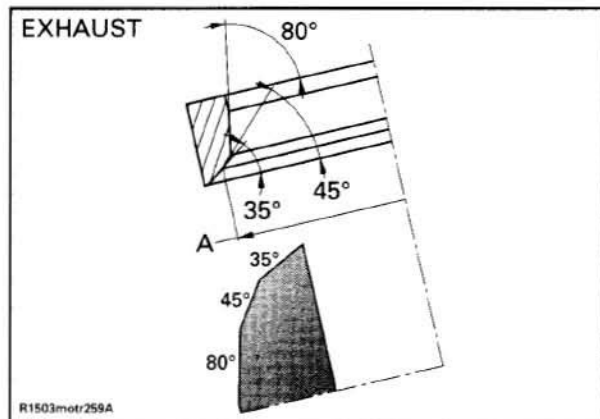

- A Valve seat outer diameter EXHAUST



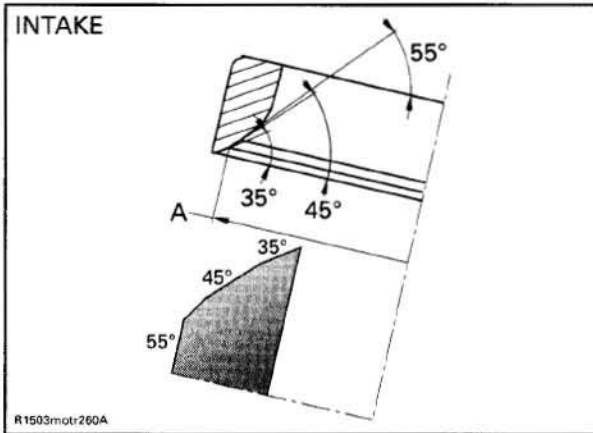

A. Valve seat outer diameter INTAKE

VALVE SEAT OUTER DIAMETER	
Intake	37.35 mm (1.4705 in)
Exhaust	30.3 mm (1.1929 in)

- Using a 55° stone for the intake and an 80° stone for the exhaust valve, reduce the valve seat contact width to the appropriate value mentioned above.
- Finally, coat the valve seating surface with a fine paste of valve grinding compound using a manual valve grinding mandrel. Lightly grind the valves until a smooth, even, uniform sealing surface of the appropriate inside and outside diameter is obtained on both the valve and the seat. Use only a hand held valve grinding mandrel with a suction cup, rotating the valve back and forth through about 45°, and then advancing the valve 45° before repeating this operation.

### Installation

For installation, reverse the removal procedure. Pay attention to the following details.

Install valve stem seal no. 33.

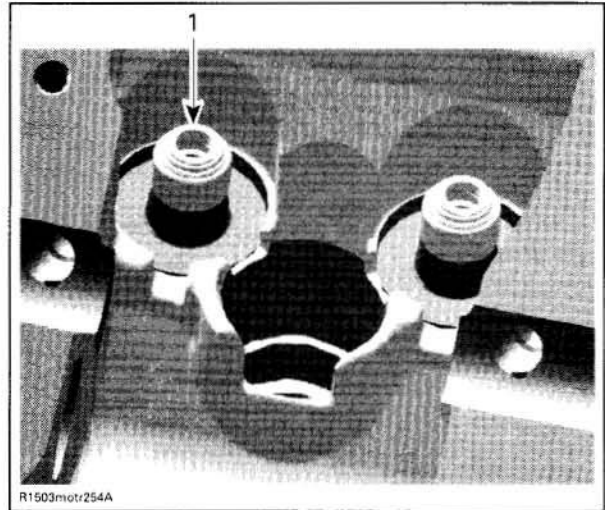

1. Valve stem seal

Apply engine oil on valve stem and install it.

**CAUTION:** Be careful when valve stem is passed through sealing lips of valve stem seal.

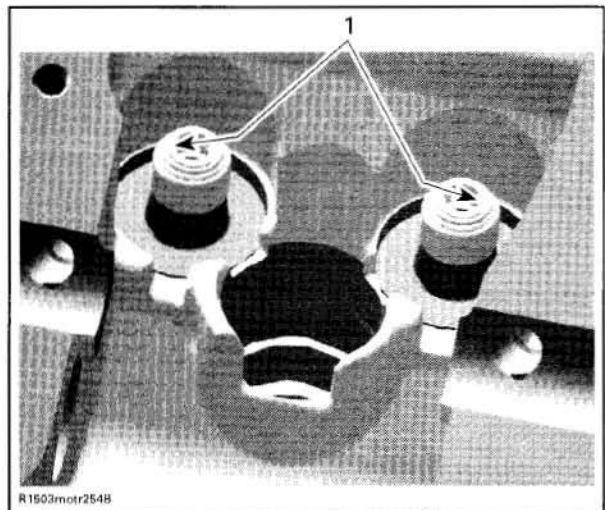

1. Sealing lips of valve stem seal

To ease installation of cotters, apply oil or grease on them so that they remain in place while releasing the spring.

After spring is installed, ensure it is properly locked by tapping on valve stem end with a soft hammer so that valve opens and closes a few times.

**CAUTION:** An improperly locked valve spring will cause engine damage.

# CYLINDER BLOCK

## SERVICE TOOLS

<b>Description</b>	<b>Part Number</b>	<b>Page</b>
crankshaft locking tool.....	529 035 821 .....	153, 157, 159, 164
handle.....	420 877 650 .....	162
piston circlip installer .....	529 035 765 .....	150
pusher.....	420 876 502 .....	162

## SERVICE PRODUCTS

<b>Description</b>	<b>Part Number</b>	<b>Page</b>
chisel gasket remover .....	413 708 500 .....	163
Loctite 243 (blue).....	293 800 060 .....	163
Loctite 5910.....	293 800 081 .....	163

# Section 03 ENGINE

## Subsection 11 (CYLINDER BLOCK)

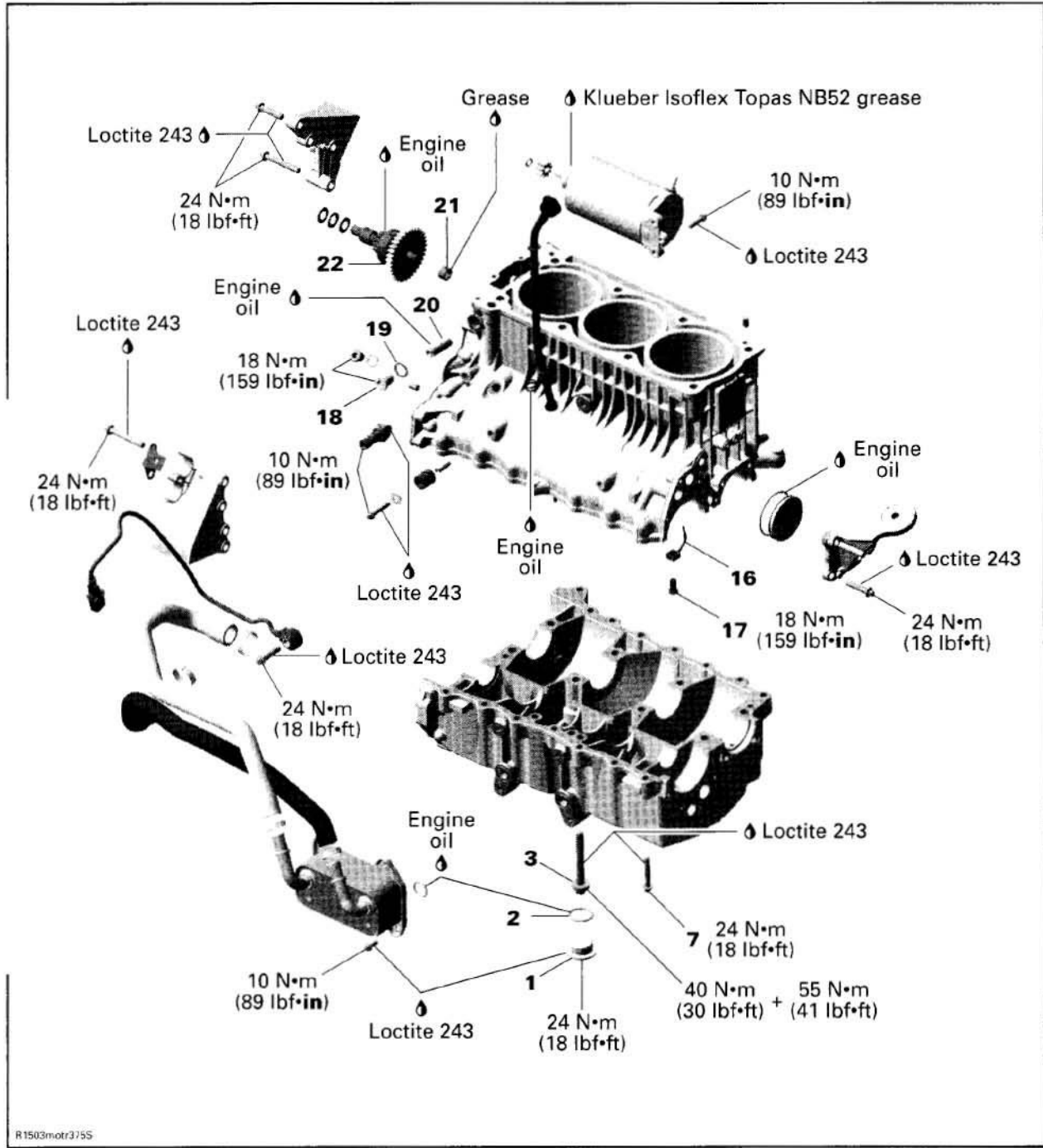

R1503motr375S



**Section 03 ENGINE**  
Subsection 11 (CYLINDER BLOCK)

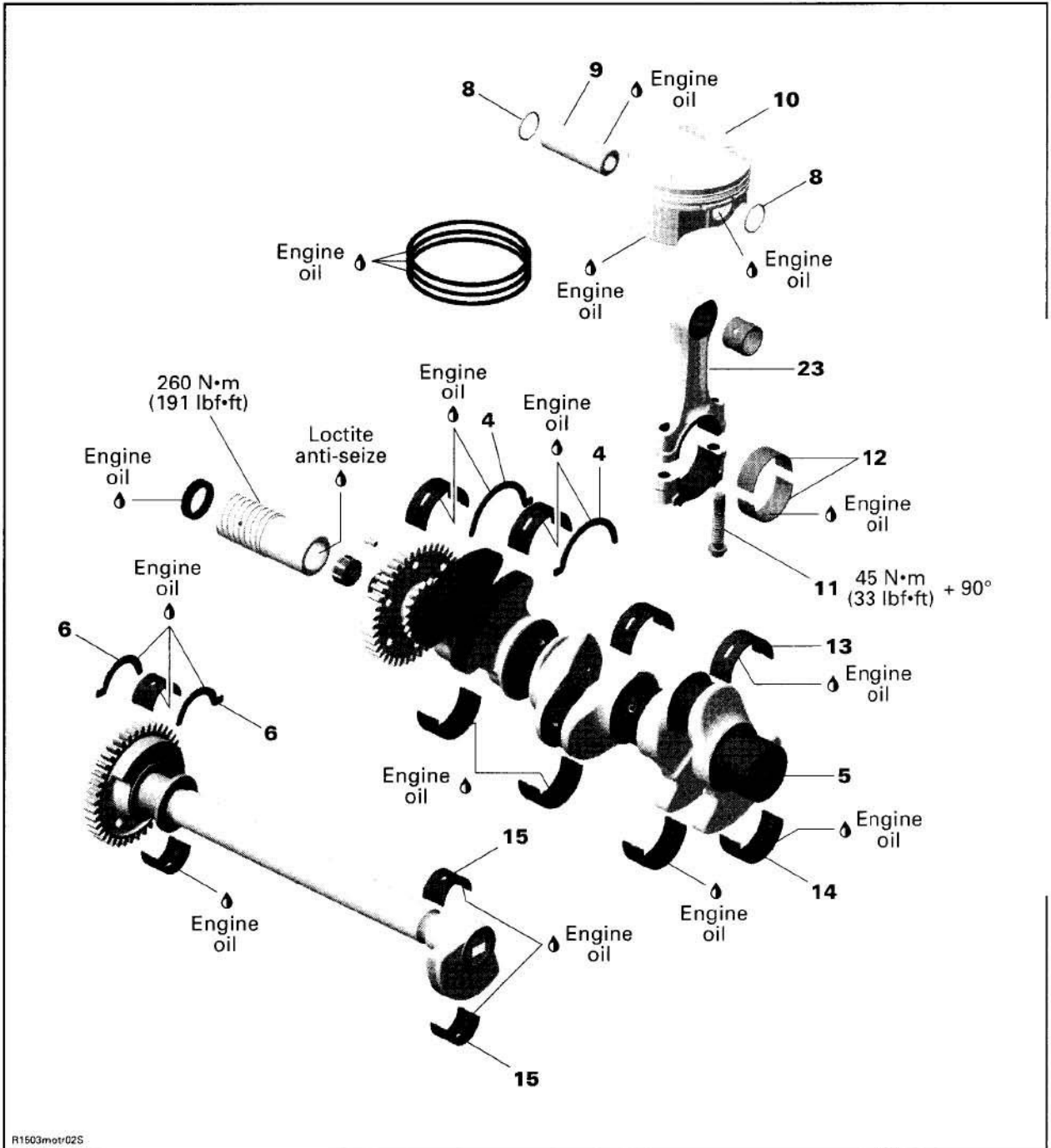

R1503motr02S

## Section 03 ENGINE

### Subsection 11 (CYLINDER BLOCK)

## GENERAL

When disassembling parts that are duplicated in the engine, (e.g.: pistons, connecting rods etc.), it is strongly recommended to note their position (cylinder 1, 2 or 3) and to keep them as a "group". If you find a defective component, it would be much easier to find the cause of the failure within the group of parts. Besides, since used parts have matched together during the engine operation, they will keep their matched fit when you reassemble them together within their "group".

## PROCEDURES

### TIMING CHAIN

#### Inspection

Check timing chain on camshaft gear for excessive radial play.

Check chain condition for wear and rollers condition.

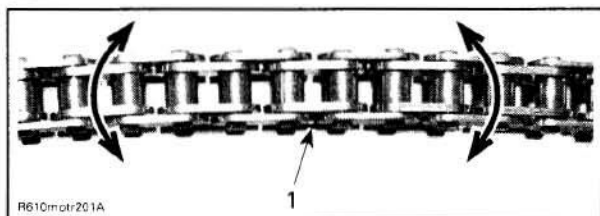

1. Timing chain

If chain is excessively worn or damaged, replace it as a set (camshaft timing gear and timing chain).

#### Removal

Remove:

- engine oil (refer *LUBRICATION SYSTEM*)
- engine from vehicle (refer to *ENGINE REMOVAL AND INSTALLATION*)
- cylinder head (refer to *CYLINDER HEAD* section)
- PTO housing (refer to *PTO HOUSING AND MAGNETO* section)
- crankshaft (refer to *CRANKSHAFT* in this section)
- timing chain.

#### Installation

The installation is essentially the reverse of the removal procedure but, pay attention to the following details.

Ensure to perform proper valve timing. Lock crankshaft and camshaft at TDC (refer to *CYLINDER HEAD* section for the camshaft locking procedure).

Install chain then, install chain tensioner.

**CAUTION:** Improper valve timing will damage engine components.

## CHAIN TENSIONER

### Removal

**NOTE:** Removal of the intake manifold allows easier access to the chain tensioner, but is not necessary. Refer to *INTAKE MANIFOLD AND INTER-COOLER* section.

Remove:

- chain tensioner plug screw no. 18 with gasket ring no. 19
- chain tensioner no. 20.

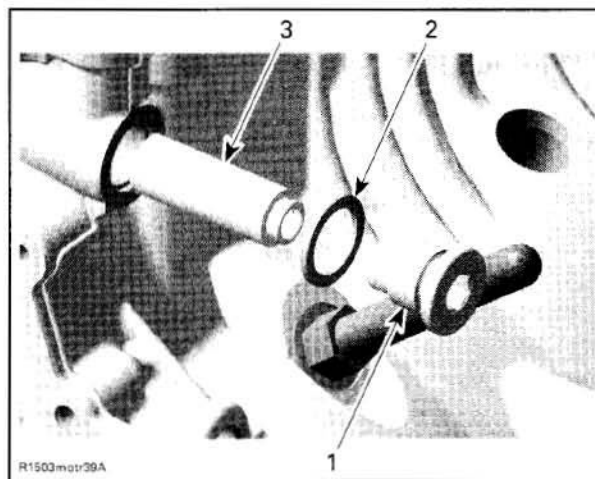

1. Plug screw
2. Gasket ring
3. Chain tensioner

### Inspection

Check chain tensioner for excessive wear or cracks. Also check free movement of the chain tensioner piston.

### Installation

The installation is essentially the reverse of the removal procedure but, pay attention to the following details.

Torque chain tensioner plug screw to 18 N•m (160 lbf•in).

## PISTON/CONNECTING ROD

### Removal

Disassemble cylinder block as per procedure in this section. Refer to *CYLINDER BLOCK*.

**NOTE:** It is recommended to measure connecting rod big end axial play prior to remove connecting rod. Refer to *INSPECTION* below.

Remove connecting rod cap screws.

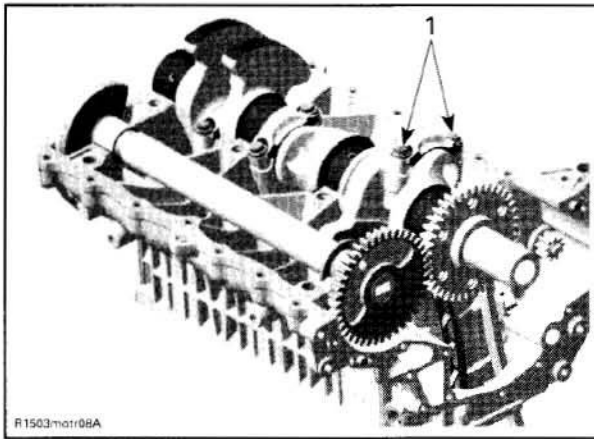

1. Connecting rod screws

**NOTE:** Before removing the connecting rod caps, mark them to remember the right position when reassembling.

Pull piston with connecting rod out of the cylinders.

Remove one piston circlip no. 8 and discard it.

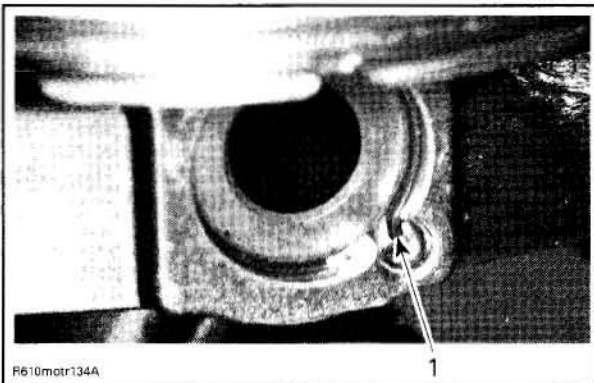

1. Piston circlip

**NOTE:** The removal of both piston circlips is not necessary to remove piston pin.

Push piston pin no. 9 out of piston.

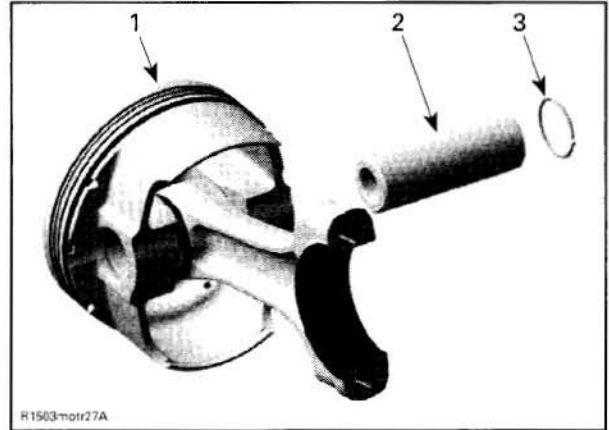

1. Piston  
2. Piston pin  
3. Circlip

Detach piston no. 10 from connecting rod.

### Inspection

#### Connecting Rod Big End Axial Play

Using a feeler gauge, measure distance between butting face of connecting rod and crankshaft counterweight. If the distance exceeds specified tolerance, replace the worn part.

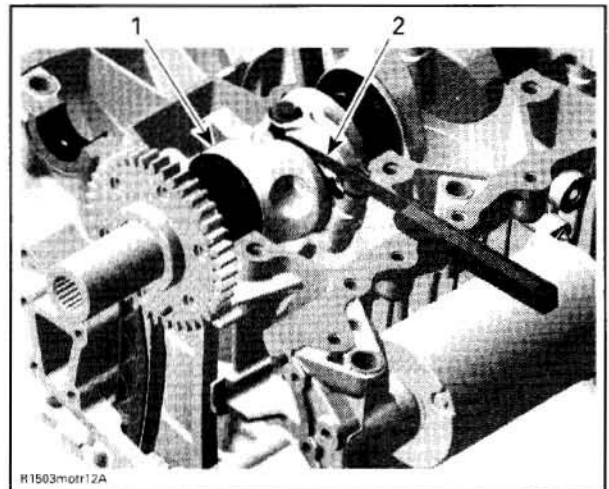

1. Crankshaft  
2. Feeler gauge

CONNECTING ROD BIG END AXIAL PLAY mm (in)	
NEW MINIMUM	0.150 (.06)
NEW MAXIMUM	0.302 (.01)
SERVICE LIMIT	0.5 (.02)

#### Connecting Rod/Piston Pin Clearance

Measure piston pin. Compare to inside diameter of connecting rod no. 5.



## Section 03 ENGINE

### Subsection 11 (CYLINDER BLOCK)

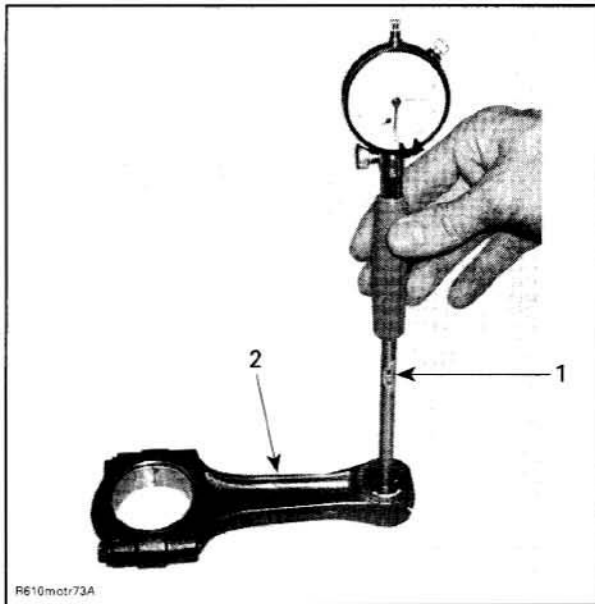

1. Bore gauge
2. Connecting rod

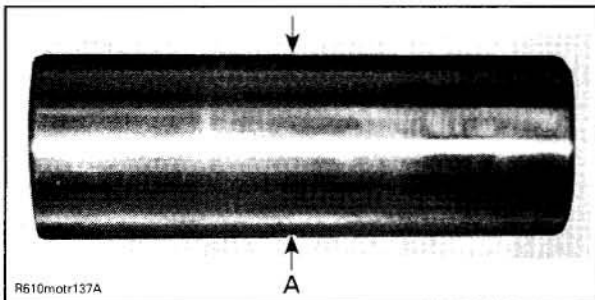

A. Piston pin diameter in the area of the bushing

CONNECTING ROD SMALL END DIAMETER mm (in)	
NEW MINIMUM	23.01 (.9059)
NEW MAXIMUM	23.02 (.9063)
SERVICE LIMIT	23.07 (.908)

PISTON PIN DIAMETER mm (in)	
NEW MINIMUM	22.996 (.9053)
NEW MAXIMUM	23.000 (.9055)
SERVICE LIMIT	22.990 (.904)

PISTON PIN BORE CLEARANCE mm (in)	
SERVICE LIMIT	0.080 (.0035)

If the connecting rod small end diameter is out of specification, replace small end bearing sleeve.

**NOTE:** For small end bearing sleeve replacement contact a machine shop. After installing a new small end bearing sleeve on the connecting rod, the inner diameter and the oil holes need to be machined to specification.

#### Connecting Rod Big End Radial Play

Measure inside diameter of connecting rod big end. Compare to crankshaft pin.

To measure the connecting rod big end diameter, use the OLD screws no. 11.

Install the OLD bearings no. 12 as they were mounted initially.

Do the torque procedure as described below.

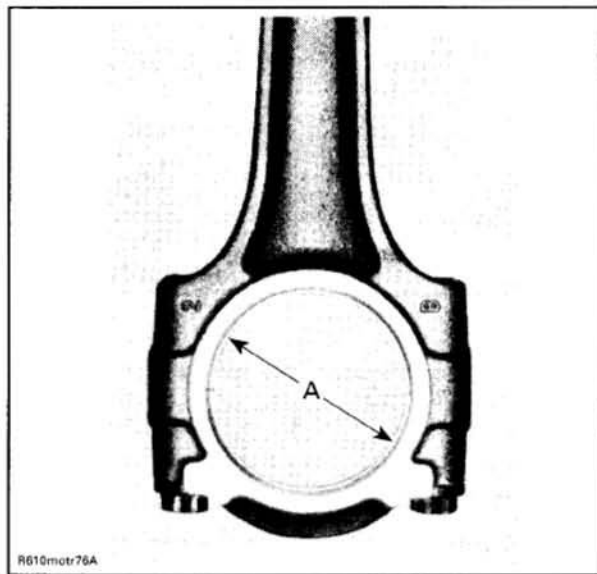

A. Connecting rod big end bearing

CONNECTING ROD BIG END DIAMETER mm (in)	
SERVICE LIMIT	45.080 (1.774)

CONNECTING ROD BIG END CLEARANCE mm (in)	
SERVICE LIMIT	0.09 (.0035)

Use NEW bearings no. 12, when connecting rod big end diameter is out of specification.

#### Piston

Inspect piston for scoring, cracking or other damages. Replace piston and piston rings if necessary.

Using a micrometer, measure piston at 18 mm (.709 in) perpendicularly (90°) to piston pin axis.

**Section 03 ENGINE**  
**Subsection 11 (CYLINDER BLOCK)**

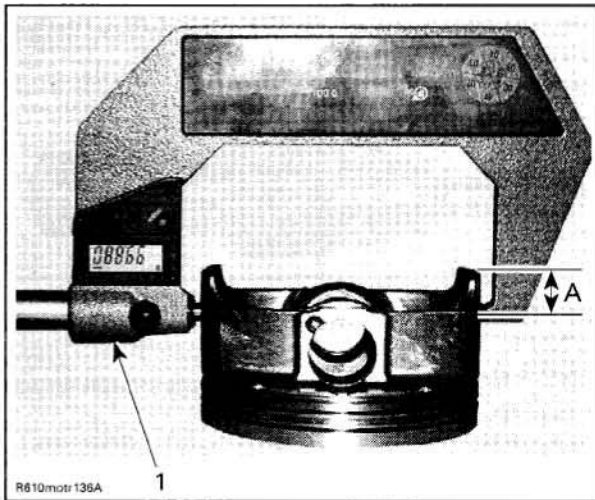

1. Measuring perpendicularly (90°) to piston pin axis  
 A. 18 mm (.709 in)

The measured dimension should be as described in the subsequent table. If not, replace piston.

PISTON MEASUREMENT mm (in)	
NEW NOMINAL	99.951 to 99.969 (3.935 to 3.936)
SERVICE LIMIT	99.90 (3.933)

**Piston/Cylinder Wall Clearance**

Adjust and lock a micrometer to the piston dimension.

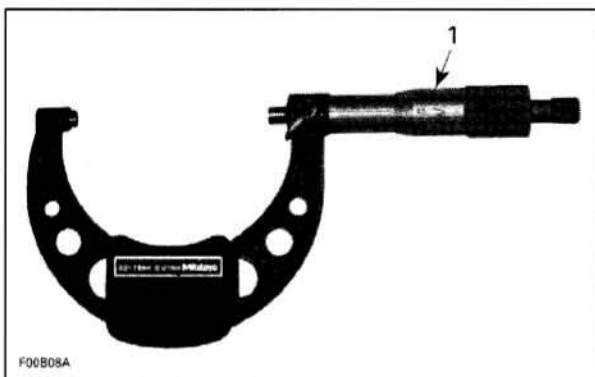

1. Micrometer set to the piston dimension

With the micrometer set to the dimension, adjust a cylinder bore gauge to the micrometer dimension and set the indicator to 0 (zero).

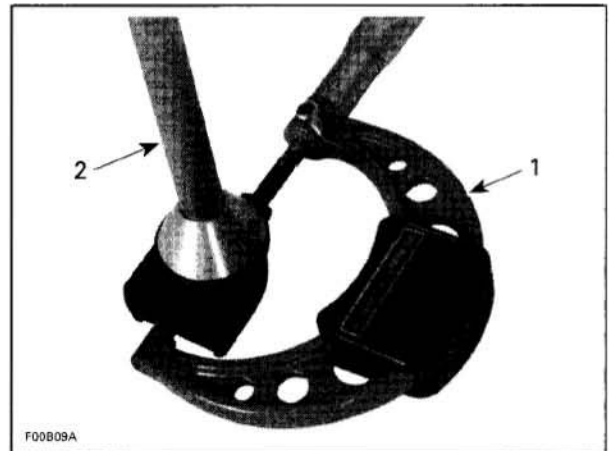

1. Use the micrometer to set the cylinder bore gauge  
 2. Dial bore gauge

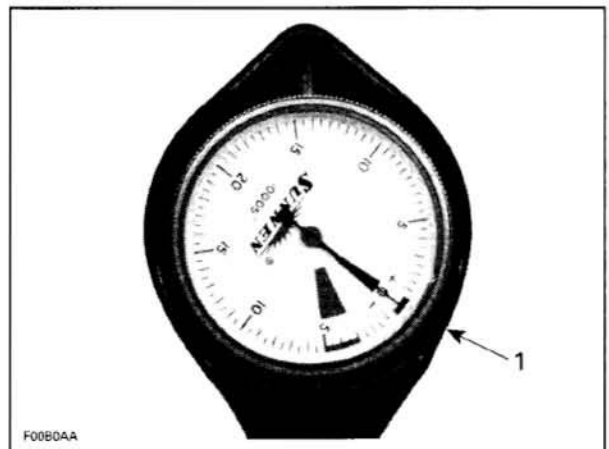

TYPICAL  
 1. Indicator set to 0 (zero)

Position the dial bore gauge 62 mm (2.44 in) above cylinder base, measuring perpendicularly (90°) to piston pin axis.

Read the measurement on the cylinder bore gauge. The result is the exact piston/cylinder wall clearance.

PISTON/CYLINDER CLEARANCE mm (in)	
NEW NOMINAL	0.024 to 0.056 (.0009 to .0022)
SERVICE LIMIT	0.090 (.004)

**NOTE:** Make sure used piston is not worn.

If clearance exceeds specified tolerance, rehone cylinder sleeve and replace piston ass'y by an oversize one.



**Section 03 ENGINE**  
**Subsection 11 (CYLINDER BLOCK)**

**NOTE:** It is not necessary to have all pistons replaced with an oversize if they are not all out of specification. Mixed standard size and oversize piston are allowed.

**NOTE:** Make sure the cylinder bore gauge indicator is set exactly at the same position as with the micrometer, otherwise the reading will be false.

**Piston Pin**

Using synthetic abrasive woven, clean piston pin from deposits.

Inspect piston pin for scoring, cracking or other damages.

Measure piston pin. See the following illustration for the proper measurement positions.

**Piston Pin/Connecting Rod Bearing Clearance**

Measure inside diameter of connecting rod.

CONNECTING ROD SMALL END DIAMETER mm (in)	
NEW MINIMUM	23.01 (.9059)
NEW MAXIMUM	23.02 (.9063)
SERVICE LIMIT	23.07 (.908)

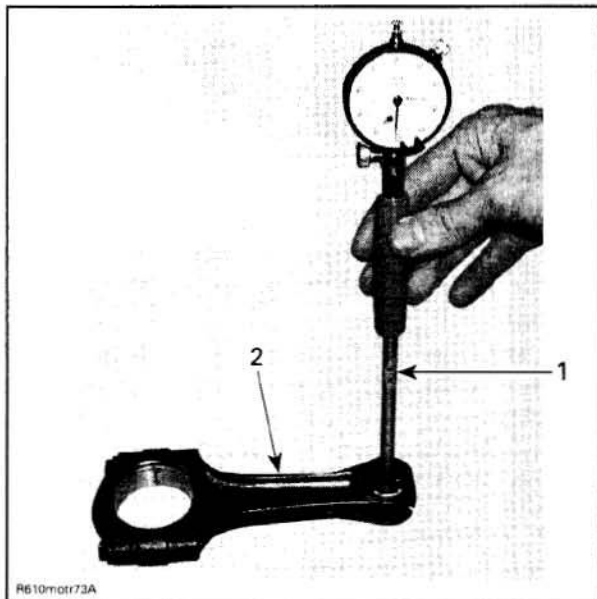

1. Bore gauge  
 2. Connecting rod

**Installation**

For installation, reverse the removal procedure. Pay attention to the following details.

Apply engine oil on the piston pin.

Insert piston pin into piston and connecting rod.

Use the piston circlip installer (P/N 529 035 765) to assemble the piston circlip.

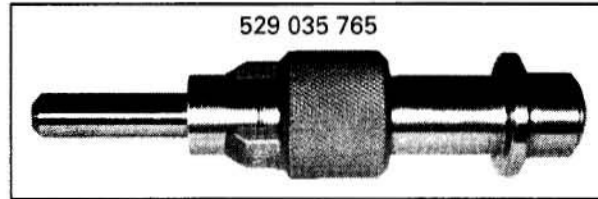

**CAUTION:** Secure piston pin with new piston circlips.

**NOTE:** Take care that the hook of the piston circlip is positioned properly.

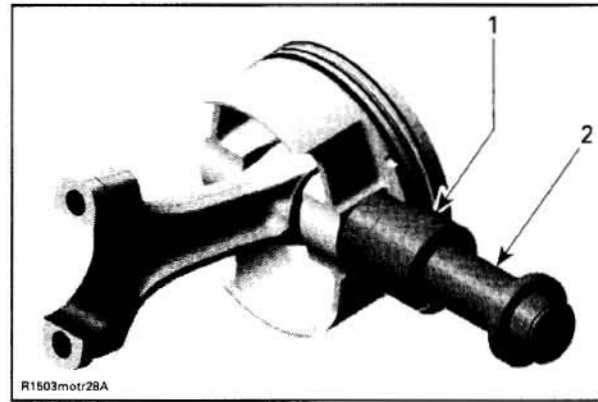

1. Sleeve with piston circlip inside  
 2. Assembly jig from piston clip installer

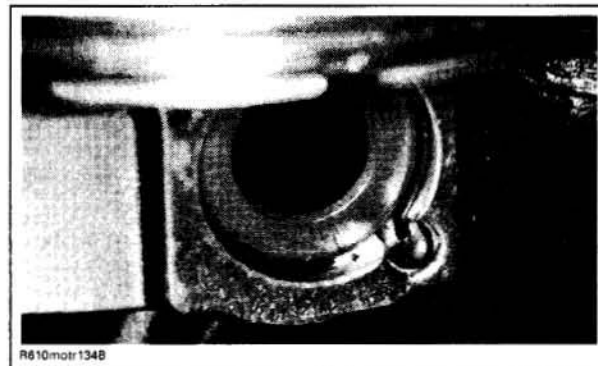

**CORRECT POSITION OF THE PISTON CIRCLIP**

Using piston ring compressor pliers, such as Snap-On RC-980, slide piston into cylinder.



**Section 03 ENGINE**  
**Subsection 11 (CYLINDER BLOCK)**

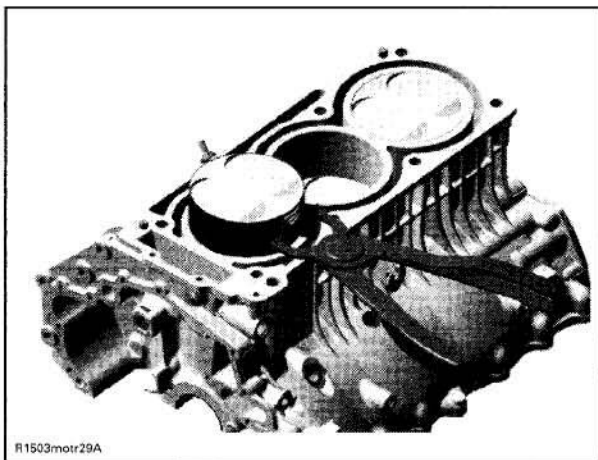

**CAUTION:** Install piston with punched arrow toward exhaust side.

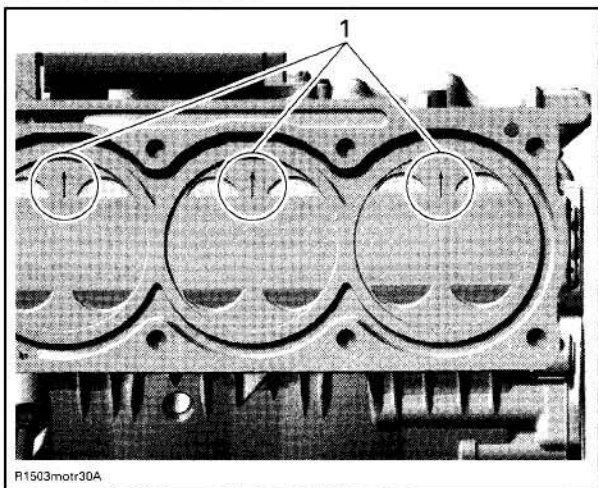

1. Arrow toward exhaust side

Correctly install bearings and carefully clean split surface on both sides (cracked area).

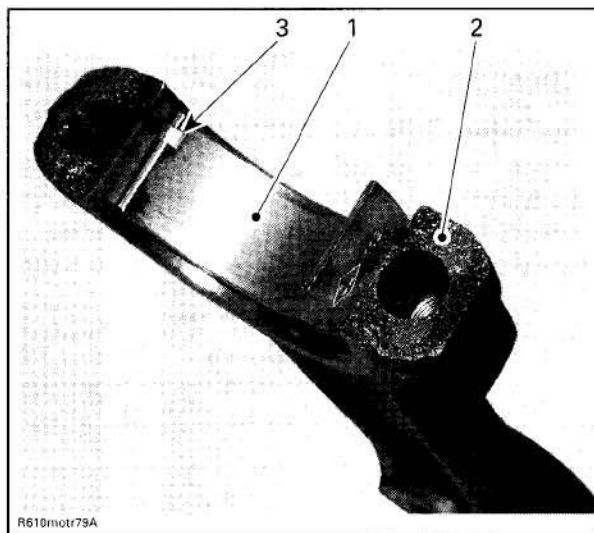

1. Half bearing of connecting rod big end
2. Split surface of the connecting rod
3. Protrusion of bearing in line with connecting rod groove

Torque NEW connecting rod screws no. 11 as per following procedure:

- Install screws and torque to 45 N•m (33 lbf•ft). Do not apply any thread locker product.
- Finish tightening the screws with an additional 90° turn using an angle torque wrench.

**CAUTION:** Failure to strictly follow this procedure may cause screw to loosen and lead to engine damage. Knowing that the screws have been stretched from the previous installation, it is very important to use new screws at assembly.

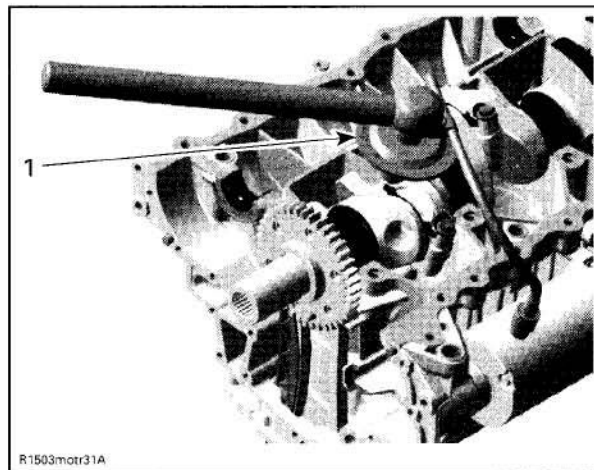

1. Angle torque wrench

**PISTON RINGS**

**Removal**

Remove piston assembly as described above.

**Section 03 ENGINE**  
**Subsection 11 (CYLINDER BLOCK)**

Remove rings.

**Inspection**

**Ring/Piston Groove Clearance**

Using a feeler gauge measure each ring/piston groove clearance. If the clearance is too large, the piston and the piston rings should be replaced.

<b>RING/PISTON GROOVE CLEARANCE mm (in)</b>	
<b>NEW MINIMUM</b>	
RECTANGULAR	0.025 (.001)
TAPER-FACE	0.015 (.0006)
OIL SCRAPER RING	0.020 (.0008)
<b>NEW MAXIMUM</b>	
RECTANGULAR	0.070 (.0028)
TAPER-FACE	0.060 (.0024)
OIL SCRAPER RING	0.055 (.0021)
<b>SERVICE LIMIT</b>	
ALL	0.15 (.006)

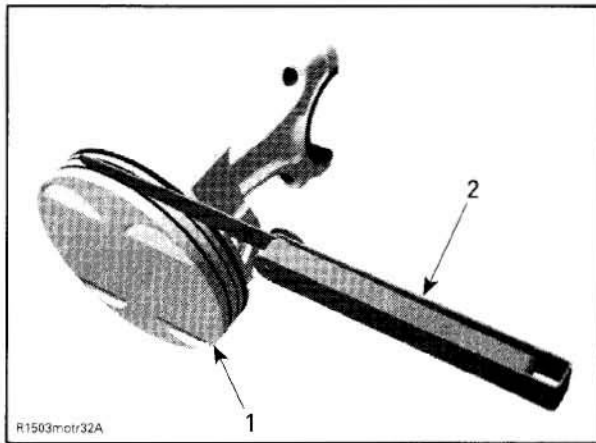

1. Piston  
 2. Filler gauge

**Ring End Gap**

<b>RING END GAP mm (in)</b>	
<b>NEW MINIMUM</b>	
RECTANGULAR	0.35 (.014)
TAPER-FACE	
OIL SCRAPER RING	
<b>NEW MAXIMUM</b>	
RECTANGULAR	0.50 (.020)
TAPER-FACE	
OIL SCRAPER RING	
<b>SERVICE LIMIT</b>	
ALL	1 (.04)

Measure position for ring end gap in the area of 8 to 16 mm (.315 to .630 in) from top of cylinder.

**NOTE:** In order to correctly position the ring in the cylinder, use piston as a pusher.

Using a feeler gauge, check ring end gap. Replace ring if gap exceeds above described specified tolerance.

**Installation**

For installation, reverse the removal procedure. Pay attention to the following details.

Install the oil scraper ring first, then the taper-face ring with the word "TO" facing up, then the rectangular ring with the word "T" facing up.

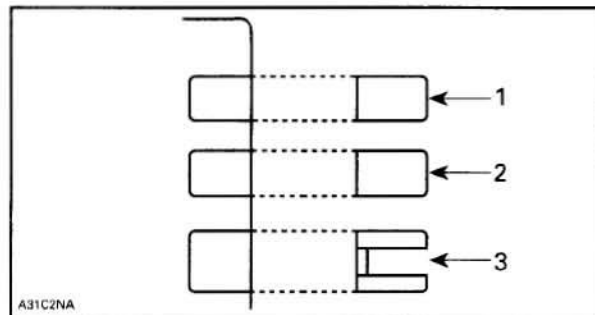

1. Rectangular ring  
 2. Taper-face ring  
 3. Oil scraper ring

**CAUTION:** Ensure that top and second rings are not interchanged

**NOTE:** Use a ring expander to prevent breakage during installation. The oil ring must be installed by hand.

Check that rings rotate smoothly after installation.



**Section 03 ENGINE**  
Subsection 11 (CYLINDER BLOCK)

Space the piston ring end gaps 120° apart and do not align the gaps with the piston pin bore or the thrust side axis.

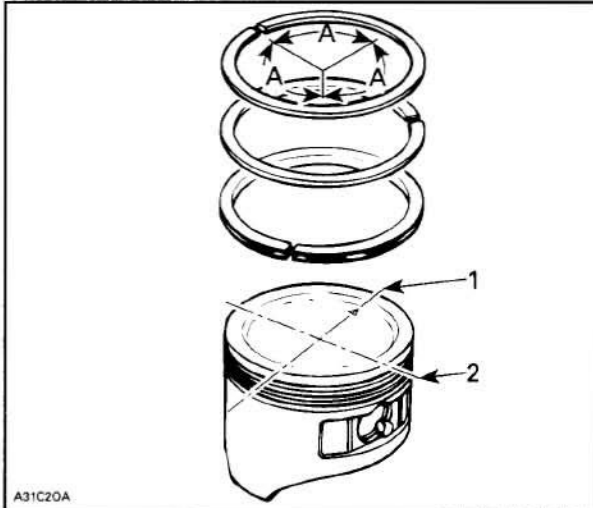

A31C20A

1. DO NOT align ring gap with piston thrust side axis  
2. DO NOT align ring gap with piston pin bore axis  
A. 120°

## CRANKSHAFT

### Crankshaft Locking

Remove:

- intake manifold (refer to *INTAKE MANIFOLD AND INTERCOOLER* section)
- engine cover
- spark plugs
- crankshaft access plug screw.

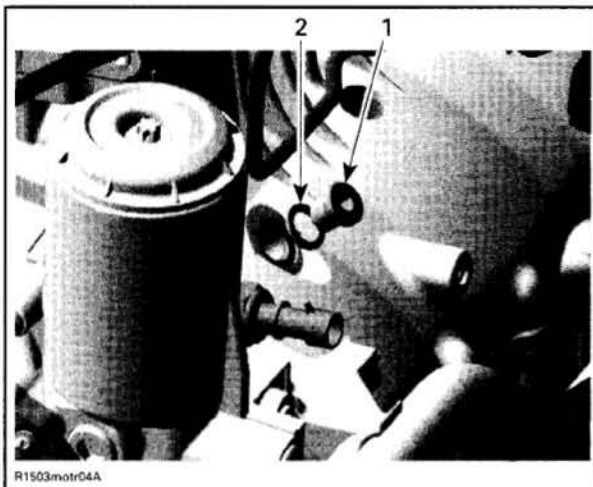

R1503motr04A

- TYPICAL**  
1. Crankshaft access plug screw  
2. Gasket ring

Put a screwdriver or similar tool into the spark plug hole of cylinder no. 3 and feel when the piston reaches TDC.

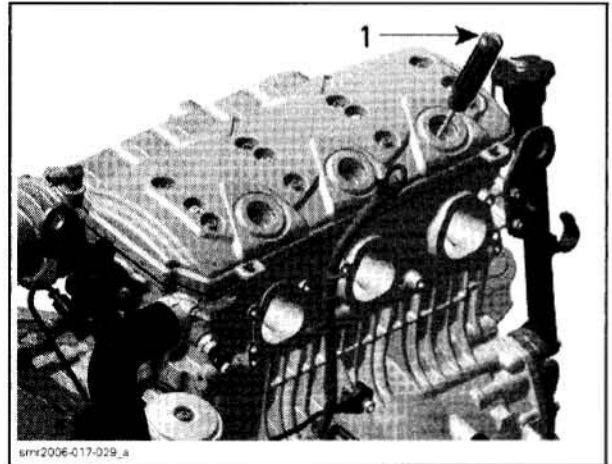

smr2006-017-029\_a

1. Screwdriver

In this position, the crankshaft can be locked by using crankshaft locking tool (P/N 529 035 821).

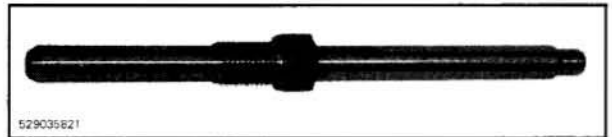

529035821

When finished, reinstall all removed parts.

### Removal

Remove:

- engine oil (refer to *LUBRICATION SYSTEM*)
- engine from vehicle (refer to *ENGINE REMOVAL AND INSTALLATION*)
- cylinder head (refer to *CYLINDER HEAD* section)
- PTO housing (refer to *PTO HOUSING AND MAGNETO* section)
- starter gear (refer to *PTO HOUSING AND MAGNETO* section)
- starter drive
- oil suction pump (refer to *LUBRICATION SYSTEM* section)
- engine mounting brackets
- oil reservoir plug screws no. 1 with O-ring no. 2



**Section 03 ENGINE**  
**Subsection 11 (CYLINDER BLOCK)**

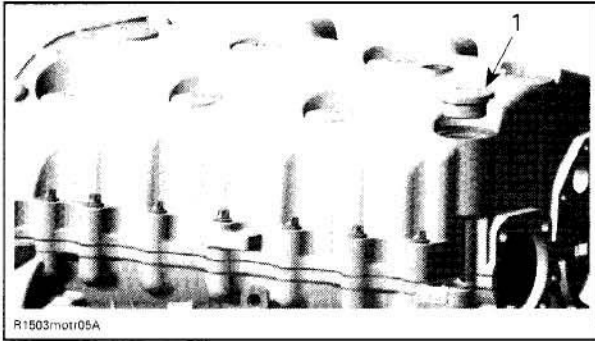

R1503motr05A  
**ENGINE UPSIDE DOWN**  
 1. Oil reservoir plug screw with O-ring

– cylinder block screws no. 3 and no. 7

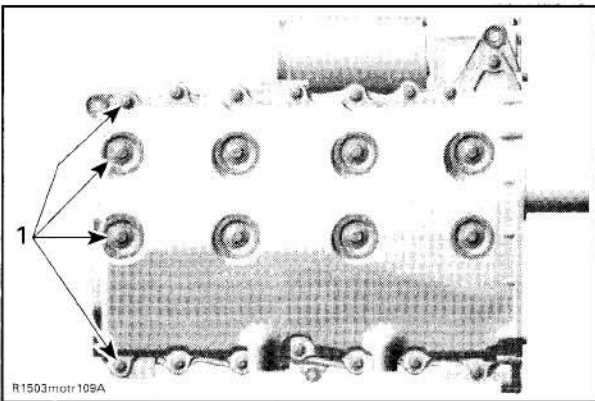

R1503motr109A  
**BOTTOM VIEW OF ENGINE**  
 1. Screws

– cylinder block lower half  
 – connecting rod screws

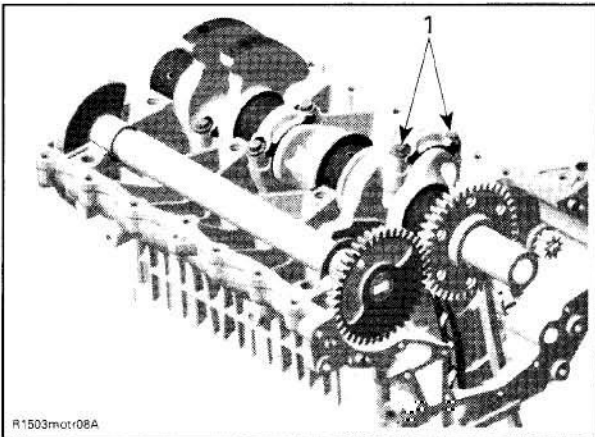

R1503motr08A  
 1. Connecting rod screws

**NOTE:** Before removing the connecting rod caps, mark them to remember the right position when reassembling. It is recommended to measure connecting rod big end axial play prior to remove connecting rod. Refer to *PISTON/CONNECTING ROD* in this section for the procedure.

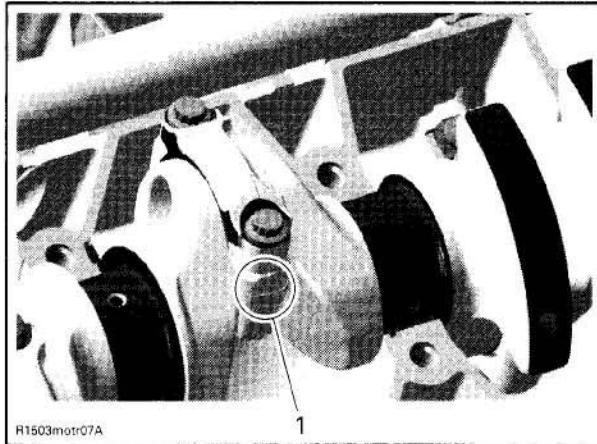

R1503motr07A  
 1. Mark on connecting rod

– thrust washers no. 4

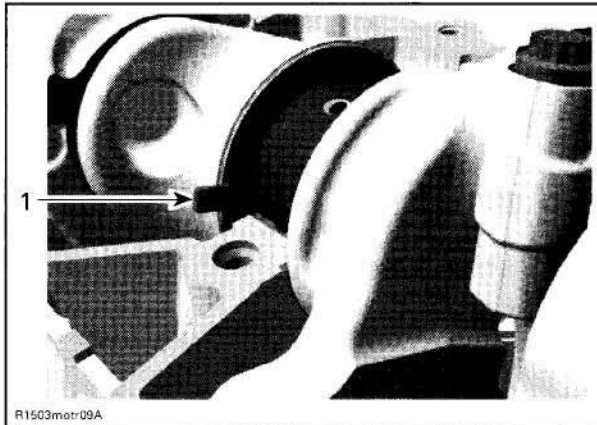

R1503motr09A  
 1. Thrust washer

– crankshaft no. 5.

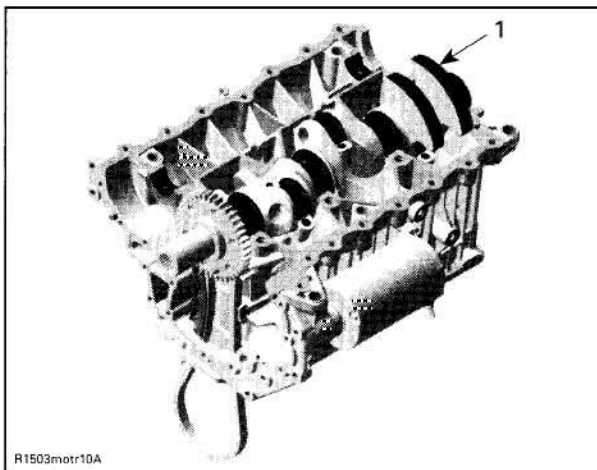

R1503motr10A  
 1. Crankshaft

**Section 03 ENGINE**  
Subsection 11 (CYLINDER BLOCK)

**Inspection**

Replace crankshaft if the gears are worn or otherwise damaged.

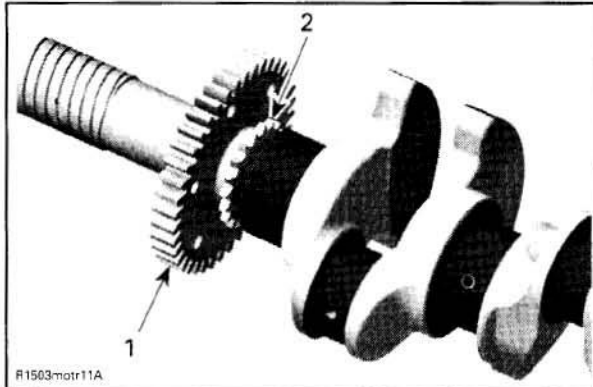

- 1. Balancer gear
- 2. Crankshaft timing gear

**Crankshaft Radial Play**

Measure all crankshaft journals. Compare to inside diameter of crankshaft bearings (elsewhere in this section).

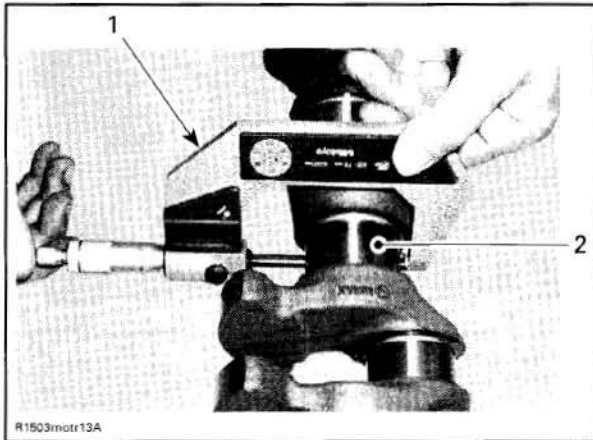

- 1. Micrometer
- 2. Crankshaft area for bearing

CRANKSHAFT JOURNAL DIAMETER mm (in)	
NEW MINIMUM	49.991 (1.9681)
NEW MAXIMUM	50.01 (1.9689)
SERVICE LIMIT	49.95 (1.9665)

CRANKSHAFT JOURNAL RADIAL CLEARANCE mm (in)	
SERVICE LIMIT	0.07 (.0028)

**Crankshaft Pin**

Measure all crankshaft pin diameters. Compare to inside diameter of connecting rod bearings (elsewhere in this section).

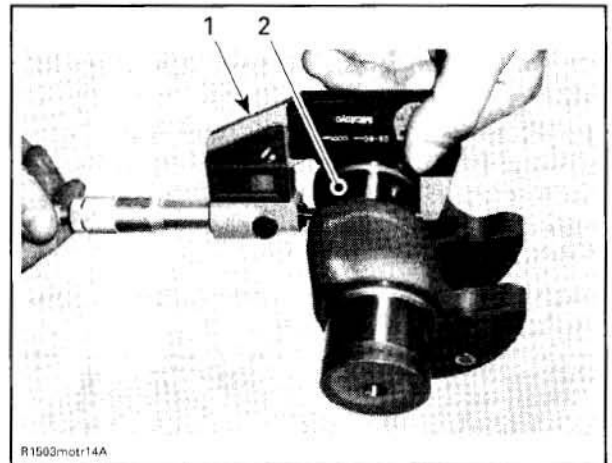

- 1. Micrometer
- 2. Crankshaft pin area for bearing

CRANKSHAFT PIN DIAMETER mm (in)	
NEW MINIMUM	45.032 (1.7729)
NEW MAXIMUM	45.048 (1.7735)
SERVICE LIMIT	45.029 (1.7728)

CRANKSHAFT PIN RADIAL CLEARANCE mm (in)	
SERVICE LIMIT	0.09 (.0035)

**Crankshaft Axial Clearance**

When assembling the cylinder-block, measure the crankshaft axial clearance:

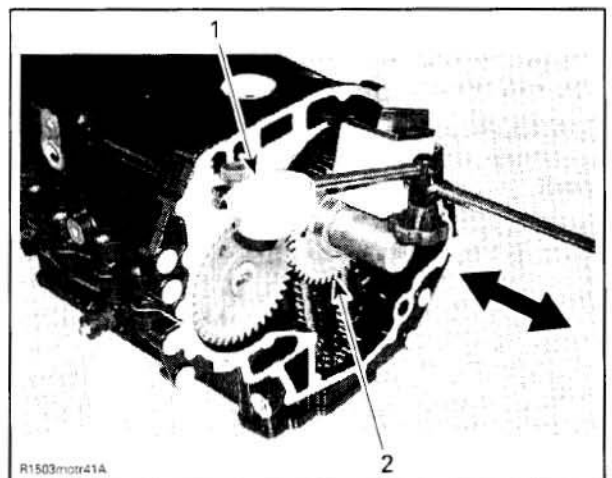

- 1. Dial gauge
- 2. Crankshaft

CRANKSHAFT AXIAL CLEARANCE mm (in)	
NEW MINIMUM	0.08 (.003)
NEW MAXIMUM	0.22 (.009)
SERVICE LIMIT	0.35 (.014)



## Section 03 ENGINE

### Subsection 11 (CYLINDER BLOCK)

#### Installation

For installation, reverse the removal procedure. Pay attention to following details.

**NOTE:** Before installing the crankshaft, make sure that the timing chain is on the crankshaft and the chain guide has been installed first. Those parts cannot be installed when the crankshaft is in place.

**CAUTION:** Crankshaft and balancer shaft marks have to be aligned.

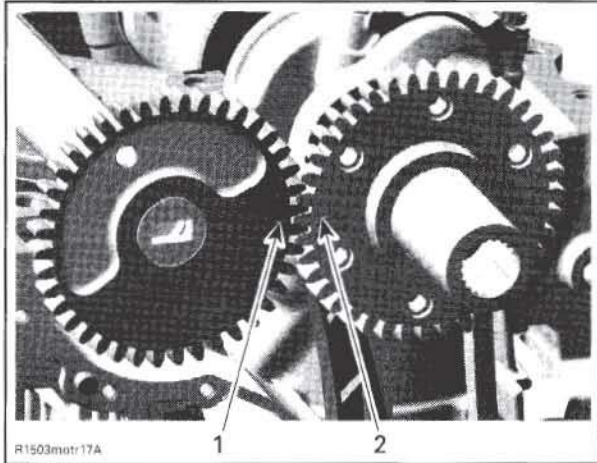

1. Mark on balancer shaft
2. Mark on crankshaft

For correct installation of the connecting rods, refer to *PISTON/CONNECTING ROD* in this section.

**CAUTION:** It is absolutely necessary to follow this procedure. Otherwise severe engine damage can occur.

**CAUTION:** Never forget thrust washers no. 4 on center of crankshaft to control axial adjustment.

Insert thrust washers as soon as crankshaft is in place as per following illustration.

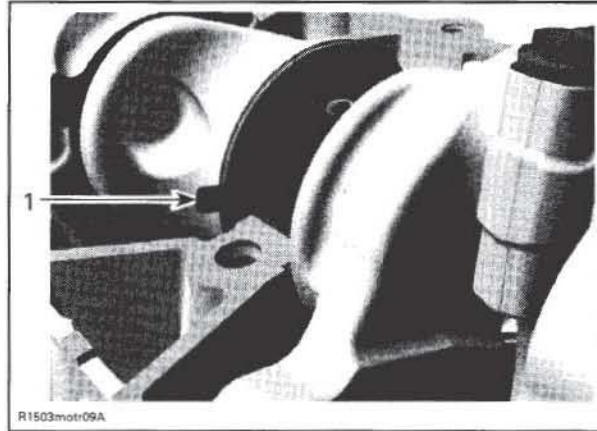

#### THRUST WASHER INSERT DIRECTION

1. Thrust washer

**CAUTION:** Thrust washers have to be flush with the cylinder block sealing surface.

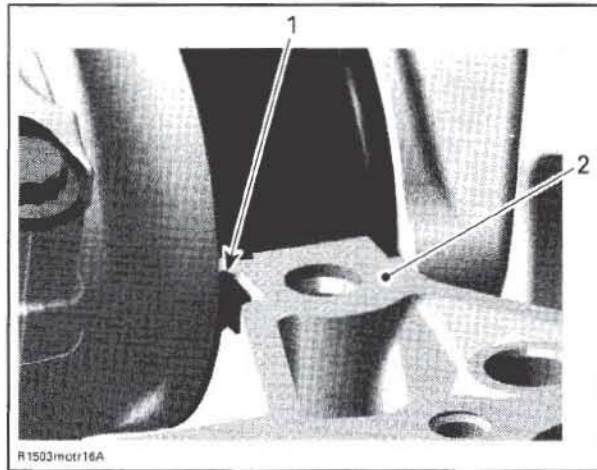

1. Thrust washer
2. Sealing surface

Install cylinder block lower half. Refer to *CYLINDER BLOCK* in this section.

Install the crankshaft cover before mounting the engine bracket. Apply oil on O-ring and press cover in. Crankshaft cover has to be flush with cylinder block surface.



## Section 03 ENGINE

### Subsection 11 (CYLINDER BLOCK)

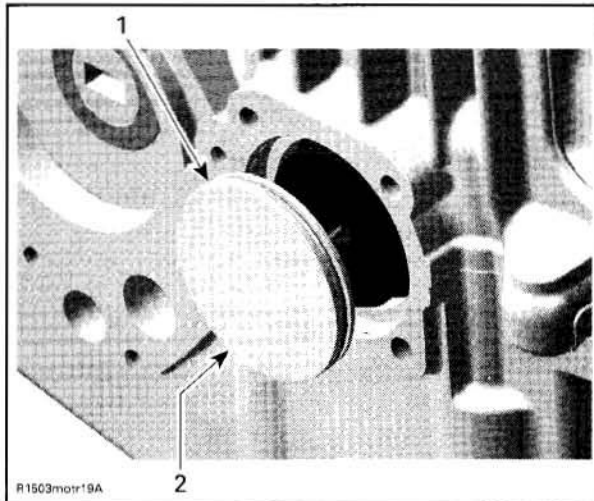

1. O-ring  
2. Crankshaft cover

**CAUTION:** Install crankshaft locking tool (P/N 529 035 821) right away to position crankshaft at TDC before installing the camshaft and rockers (refer to *CYLINDER HEAD*).

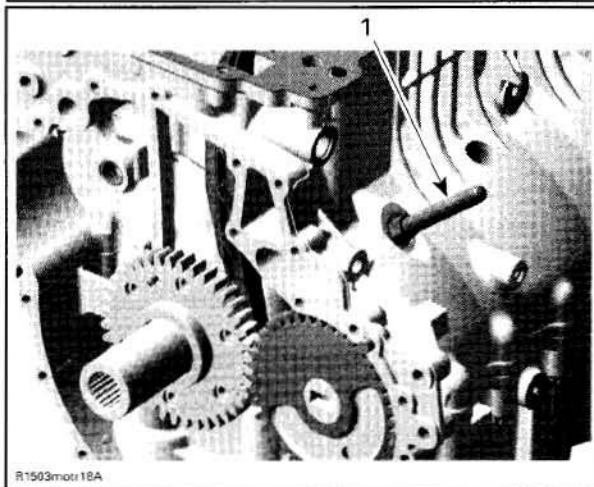
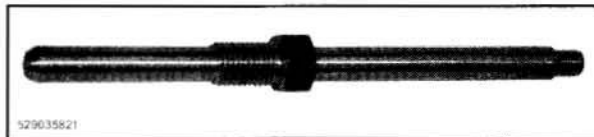

1. Crankshaft locking tool

- cylinder head (refer to *CYLINDER HEAD* section)
- PTO housing (refer to *PTO HOUSING AND MAGNETO* section)
- starter gear (refer to *PTO HOUSING AND MAGNETO* section)
- starter drive
- oil suction pump (refer to *LUBRICATION SYSTEM* section)
- engine mounting brackets
- oil reservoir plug screws no. 1 with O-ring no. 2

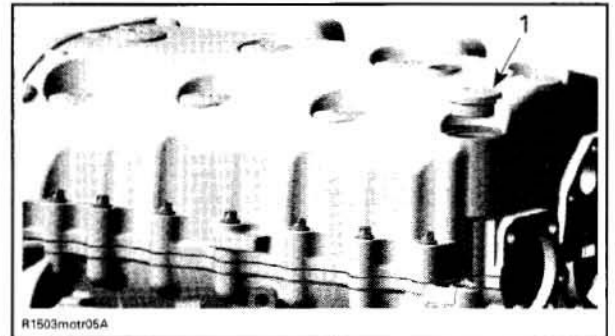

**ENGINE UPSIDE DOWN**  
1. Oil reservoir plug screw with O-ring

- cylinder block screws no. 3

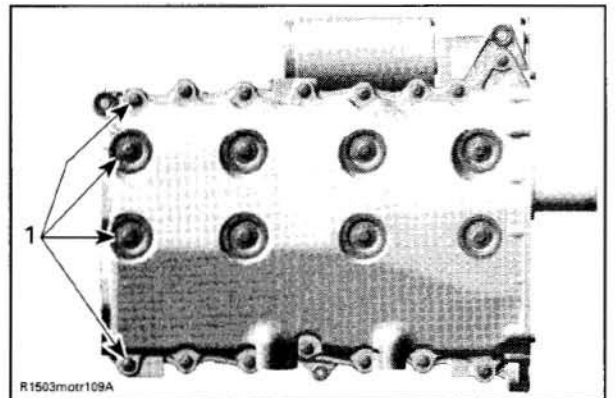

1. Screws

- cylinder block lower half
- thrust washers no. 6

## BALANCER SHAFT

### Removal

Remove:

- engine oil (refer to *LUBRICATION SYSTEM*)
- engine from vehicle (refer to *ENGINE REMOVAL AND INSTALLATION*)

## Section 03 ENGINE

### Subsection 11 (CYLINDER BLOCK)

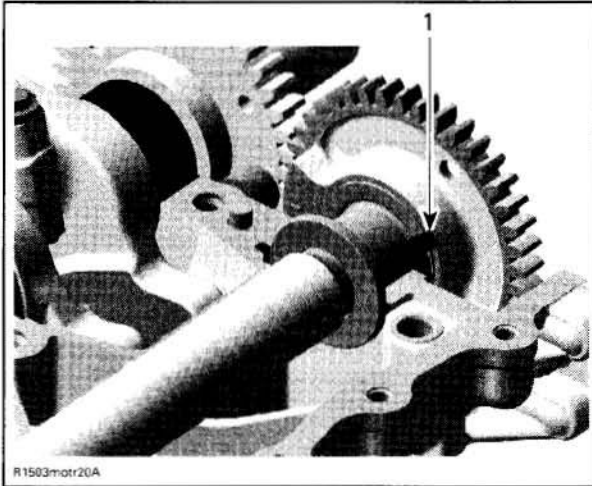

1. Thrust washer

– balancer shaft.

#### Inspection

Check balancer shaft and replace if damaged.

If the gear on the balancer shaft is damaged, replace balancer shaft.

Check gear on the crankshaft at the same time and replace crankshaft if necessary (refer to *CRANK-SHAFT* above).

#### Balancer Shaft Bearing Seat Play

Measure all balancer shaft bearing seats. Compare to inside diameter of balancer shaft bearings (elsewhere in this section).

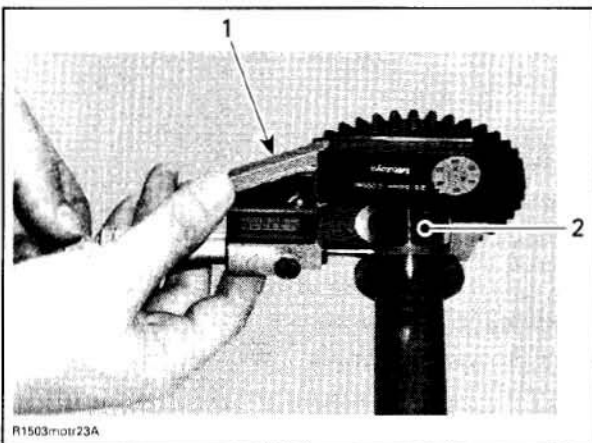

1. Micrometer  
2. Balancer shaft area for bearing

BALANCER SHAFT SEAT DIAMETER mm (in)	
NEW MINIMUM	31.984 (1.2592)
NEW MAXIMUM	32.000 (1.2598)
SERVICE LIMIT	31.960 (1.2583)

#### BALANCER SHAFT SEAT RADIAL CLEARANCE mm (in)

SERVICE LIMIT	0.07 (.0028)
---------------	--------------

#### Balancer Shaft Axial Clearance

When assembling the cylinder-block, measure the balance shaft axial play:

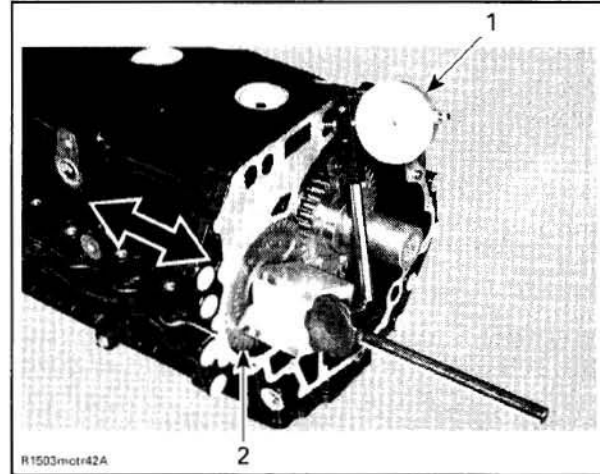

1. Dial gauge  
2. Balancer shaft

#### BALANCER SHAFT AXIAL CLEARANCE mm (in)

NEW MINIMUM	0.02 (.001)
NEW MAXIMUM	0.25 (.010)
SERVICE LIMIT	0.35 (.014)

#### Installation

For installation, reverse the removal procedure. Pay attention to following detail.

**CAUTION:** Balancer shaft and crankshaft marks have to be aligned.



**Section 03 ENGINE**  
**Subsection 11 (CYLINDER BLOCK)**

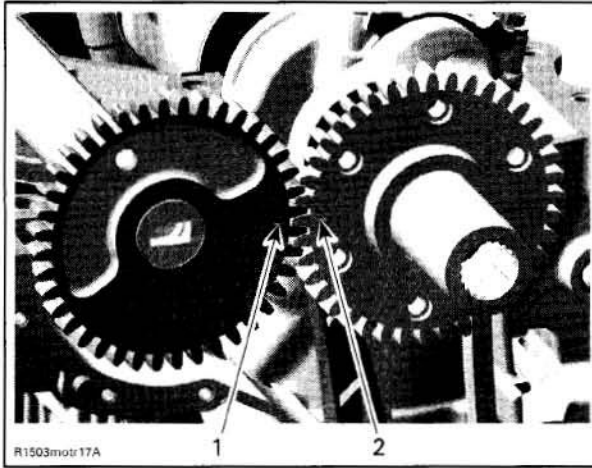

1. Mark on balancer shaft
2. Mark on crankshaft

**CAUTION:** Never forget thrust washers no. 6 on PTO side to control axial adjustment on balancer.

Insert thrust washers as soon as balancer shaft is in place as per following illustration.

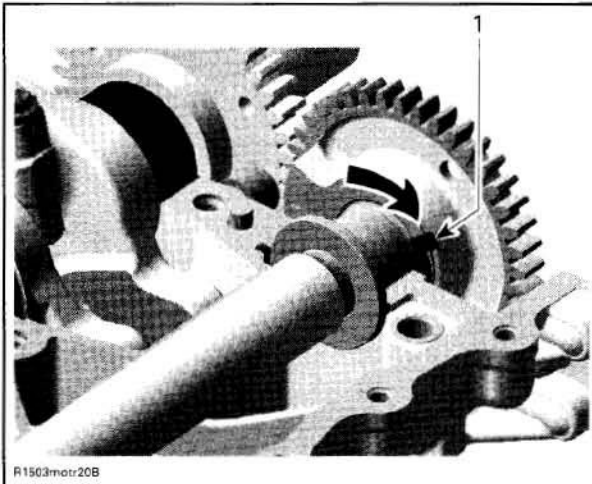

- THRUST WASHER INSERT DIRECTION**
1. Thrust washer

**CAUTION:** Thrust washers have to be flush with the cylinder block sealing surface.

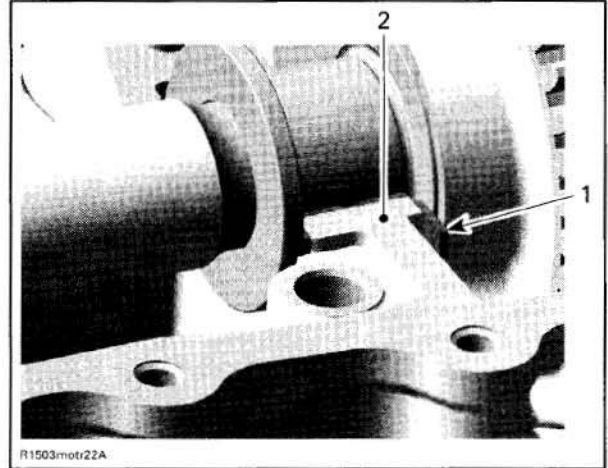

1. Thrust washer
2. Sealing surface

Install cylinder block lower half. Refer to *CYLINDER BLOCK* in this section.

Install the crankshaft cover before mounting the engine bracket. Apply oil on O-ring and press cover in. Crankshaft cover has to be flush with cylinder block surface.

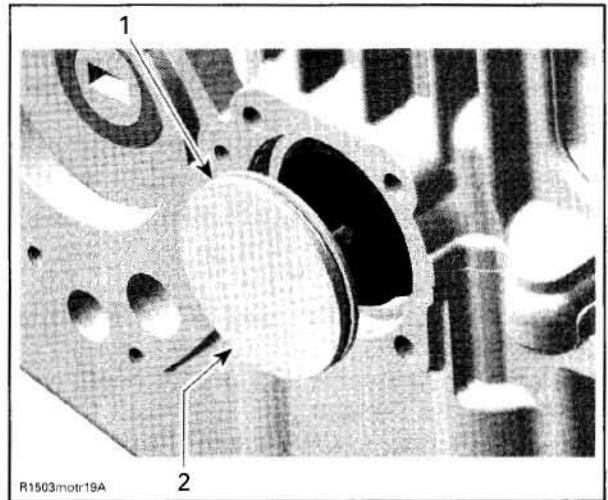

1. O-ring
2. Crankshaft cover

**CAUTION:** Install crankshaft locking tool (P/N 529 035 821) right away to position crankshaft at TDC before installing the camshaft and rockers (refer to *CYLINDER HEAD*).

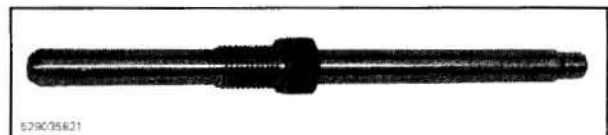



## Section 03 ENGINE

### Subsection 11 (CYLINDER BLOCK)

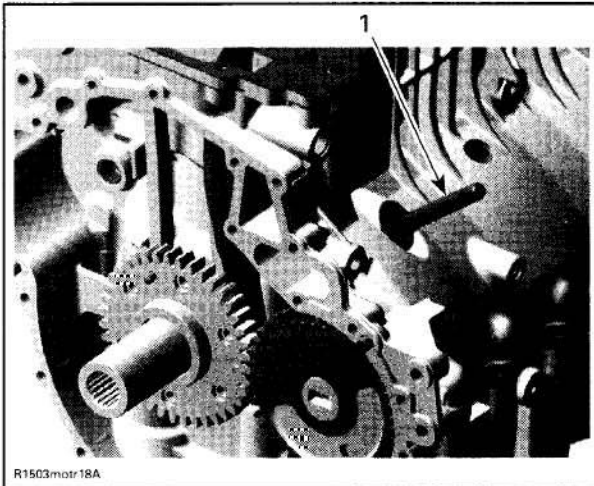

1. Crankshaft locking tool

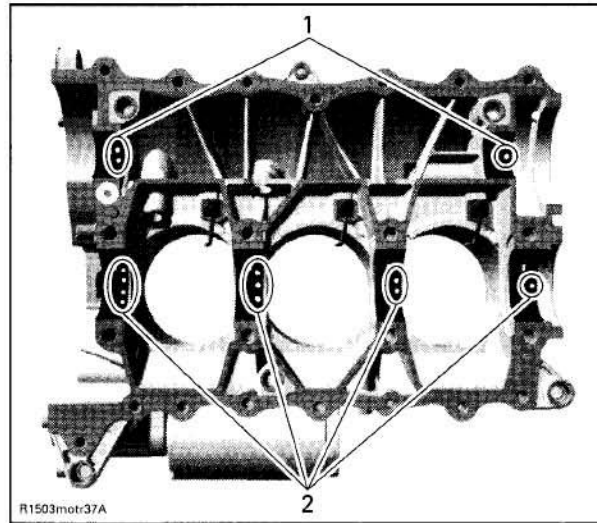

1. Mark on balancer shaft bearings
2. Mark on crankshaft bearings

## CYLINDER BLOCK

### Disassembly

Remove:

- engine oil (refer to *LUBRICATION SYSTEM*)
- engine from vehicle (refer to *ENGINE REMOVAL AND INSTALLATION*)
- cylinder head (refer to *CYLINDER HEAD* section)
- PTO housing (refer to *PTO HOUSING AND MAGNETO* section)
- starter gear (refer to *PTO HOUSING AND MAGNETO* section)
- starter drive
- oil suction pump (refer to *LUBRICATION SYSTEM* section)
- balancer shaft (refer to *BALANCER SHAFT* elsewhere in this section)
- crankshaft (refer to *CRANKSHAFT* elsewhere in this section)
- piston with connecting rod (refer to *PISTON/CONNECTING ROD* elsewhere in this section).

### Bearings

When bearings need to be removed from the cylinder block, mark them to identify the correct position at installation. See the following illustration for an example:

### Starter Drive Bearing

Check bearing no. 21 of starter drive assembly no. 22 in cylinder block and replace it if damaged.

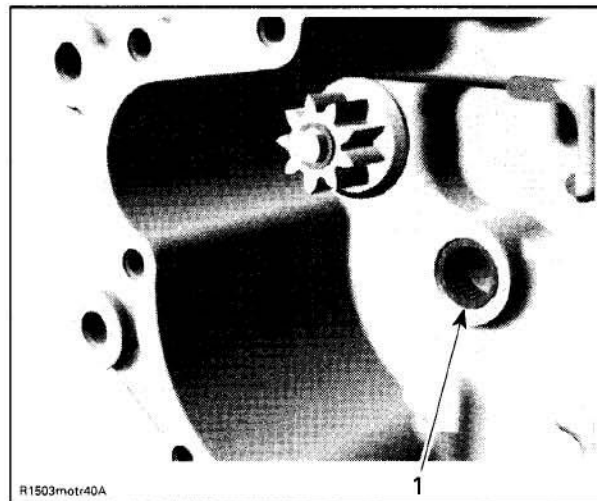

#### TYPICAL

1. Bearing of starter drive assembly

Starter drive bearing can be easily removed from crankcase lower half using the following suggested tool or equivalent:

- Snap-on hammer puller including:
  - handle CJ93-1
  - hammer CJ125-6
  - claws CJ93-4.

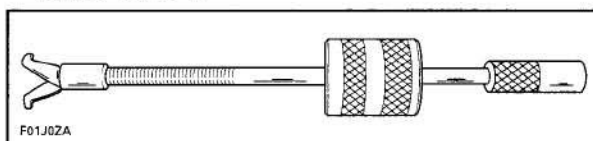

**Section 03 ENGINE**  
Subsection 11 (CYLINDER BLOCK)

Close puller claws so that they can be inserted in end bearing. Holding claws, turn puller shaft clockwise so that claws open and become firmly tight against bearing.

Slide puller hammer outwards and tap puller end. Retighten claws as necessary to always maintain them tight against bearing. Continue this way until bearing completely comes out.

**Inspection**

**Cylinder**

Check cylinder for cracks, scoring and wear ridges on the top and bottom of the cylinder. If so, replace cylinder.

**Cylinder Taper**

Measure cylinder bore and if it is out of specifications, rehone cylinder sleeve and replace piston ass'y with first oversize.

**NOTE:** It is not necessary to have all cylinders rehone if they are not all out of specification. Mixed standard size and oversize cylinders are allowed.

Measure cylinder bore at 3 recommended positions. See the following illustration.

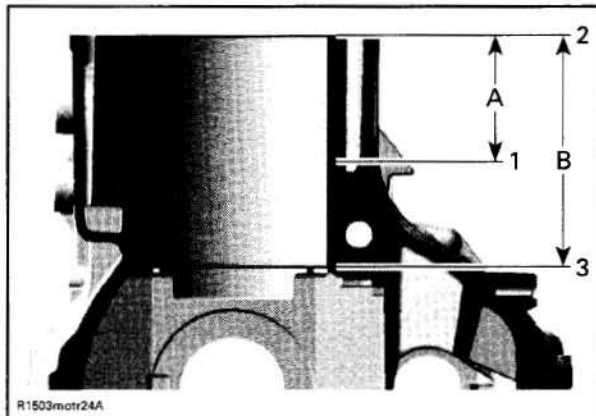

- 1. First measuring diameter
- 2. Second measuring diameter
- 3. Third measuring diameter
- A. 60 mm (2.362 in)
- B. 110 mm (4.331 in)

<b>CYLINDER TAPER IN DIAMETER mm (in)</b>	
<b>NEW MAXIMUM</b>	0.038 (.001)
<b>SERVICE LIMIT</b>	0.090 (.004)

Distance between measurements should not exceed the service limit mentioned above.

**Cylinder Out of Round**

Measure cylinder diameter in piston axis direction from top of cylinder. Take an other measurement 90° from first one and compare.

**NOTE:** Take the same measuring points as described in *CYLINDER TAPER* above.

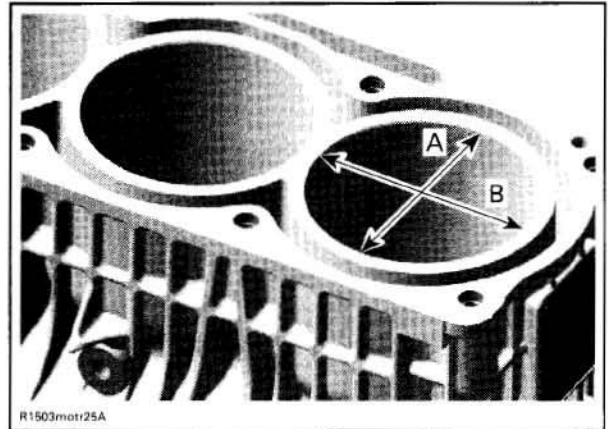

A. Perpendicular to crankshaft axis  
B. Parallel to crankshaft axis

<b>CYLINDER OUT OF ROUND mm (in)</b>	
<b>NEW MAXIMUM</b>	0.008 (.0003)
<b>SERVICE LIMIT</b>	0.015 (.0006)

**Bearings**

To measure the wear of the crankshaft bearings no. 13 and no. 14 and balancer shaft bearings no. 15, both cylinder block halves with OLD bearings have to be screwed together as per tightening procedure described below.

Measure the inside diameter of the bearings with a bore gauge.

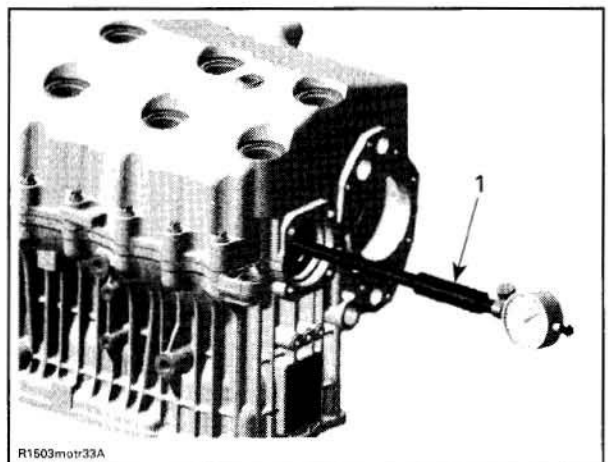

**ENGINE UPSIDE DOWN**  
1. Bore gauge



## Section 03 ENGINE

### Subsection 11 (CYLINDER BLOCK)

#### CRANKSHAFT BEARING INSIDE DIAMETER mm (in)

SERVICE LIMIT	50.1 (1.9724)
---------------	---------------

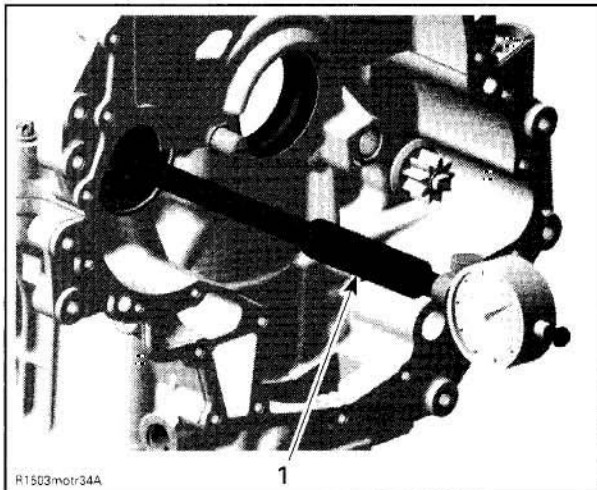

ENGINE UPSIDE DOWN  
1. Bore gauge

#### BALANCER SHAFT BEARING INSIDE DIAMETER mm (in)

SERVICE LIMIT	32.11 mm (1.2642 in)
---------------	----------------------

Replace bearings if they are out of specifications.

#### Oil Spray Nozzles

Remove oil spray nozzle no. 16 and banjo screw no. 17 from cylinder block.

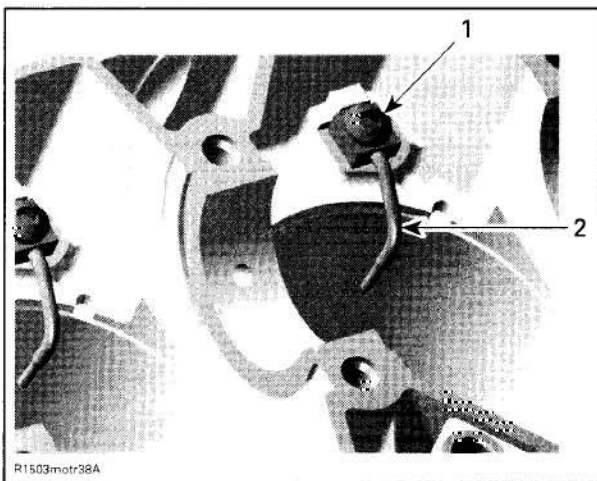

1. Banjo screw  
2. Oil spray nozzle

Check if ball inside moves freely in the banjo screw. Clean Nozzle and banjo screw from dirt and debris.

#### Assembly

For assembly, reverse the disassembly procedure. Pay attention to the following details.

Torque oil spray nozzle to 18 N•m (160 lbf•in).

To install starter drive bearing no. 21 of starter drive assembly, use pusher (P/N 420 876 502) and handle (P/N 420 877 650).

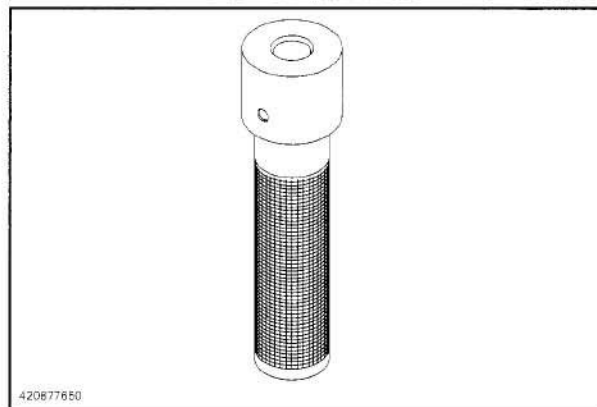
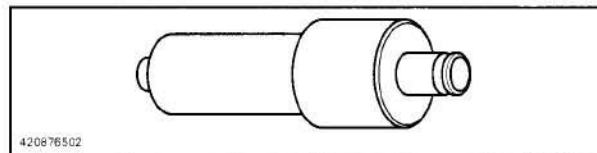

Use NEW bearings when diameters are out of specification.

If OLD bearings can be used again, make sure they are at the same position as they were before.

Correctly install bearings. Top crankshaft bearing halves have a bore which has to be placed in the upper cylinder block.

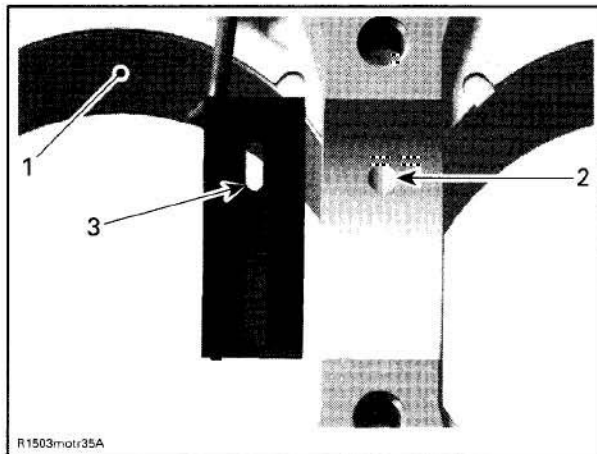

1. Cylinder block upper half  
2. Oil bore in cylinder block  
3. Oil bore in bearing



## Section 03 ENGINE

### Subsection 11 (CYLINDER BLOCK)

Bearings have to be flush with the cylinder block split surface and their protrusions have to fit in the notched areas in the cylinder block seat.

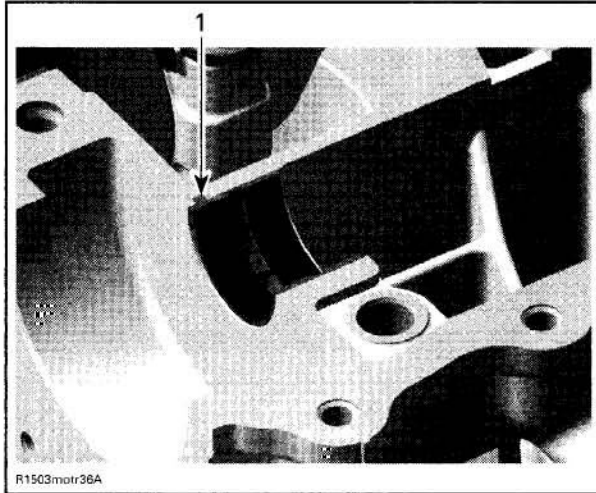

1. Bearing protrusion in cylinder block notch

Apply engine oil on all bearings, in the bottom area of the cylinder bore and also on the band of the piston ring compressor tool.

For proper installation of pistons, refer to *PISTON/CONNECTING ROD* in this section.

**NOTE:** Before installing the crankshaft, make sure that the timing chain is on the crankshaft and the chain guide has been installed first. Those parts cannot be installed after as the crankshaft is in place.

Clean oil passages and make sure they are not clogged.

Clean all metal components in a solvent.

Cylinder block mating surfaces are best cleaned using a combination of the chisel gasket remover (P/N 413 708 500) and a brass brush. Brush a first pass in one direction then make the final brushing perpendicularly (90°) to the first pass (cross hatch).

**CAUTION:** Do not wipe with rags. Use a new clean hand towel only.

**IMPORTANT:** When beginning the application of the crankcase sealant, the assembly and the first torquing should be done within 10 minutes. It is suggested to have all you need on hand to save time.

**NOTE:** It is recommended to apply this specific sealant as described here to get an uniform application without lumps. If you do not use the roller method, you may use your finger to uniformly distribute this sealant.

Use the silicone-based Loctite 5910 (P/N 293 800 081) on mating surfaces.

**CAUTION:** Do not use other products to seal crankcase. Do not use an activator with the Loctite 5910. Using other products or non silicone-based sealant over a previously sealed crankcase with Loctite 5910 will lead to poor adhesion and possibly a leaking crankcase.

**NOTE:** Refer to the product label for the sealant curing time. Respect the manufacturer's recommendations prior to start engine.

Use a plexiglass plate and apply some sealant on it. Use a soft rubber roller (50 - 75 mm (2 - 3 in)) (available in arts products suppliers for printmaking) and roll the sealant to get a thin uniform coat on the plate (spread as necessary). When ready, apply the sealant on crankcase mating surfaces.

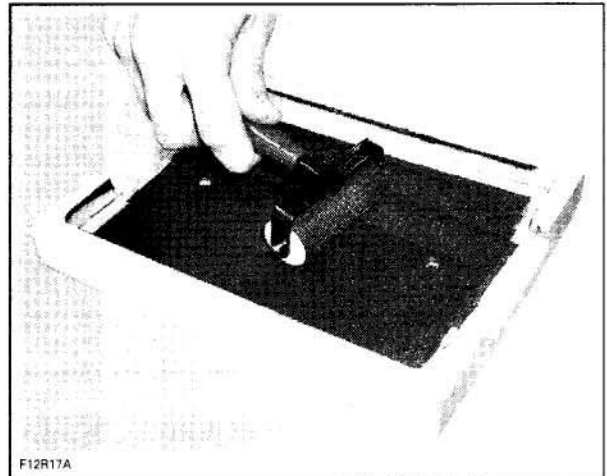

Do not apply in excess as it will spread out inside crankcase.

Tighten cylinder block screws as per following procedure:

Apply Loctite 243 (blue) (P/N 293 800 060) on screw threads.

Torque cylinder block screws no. 3 to 40 N•m (29 lbf•ft) following sequence 1 to 8 and then to 55 N•m (41 lbf•ft) (repeat sequence).

Torque cylinder block screws no. 7 to 22 N•m (17 lbf•ft) following sequence 9 to 23.

## Section 03 ENGINE

### Subsection 11 (CYLINDER BLOCK)

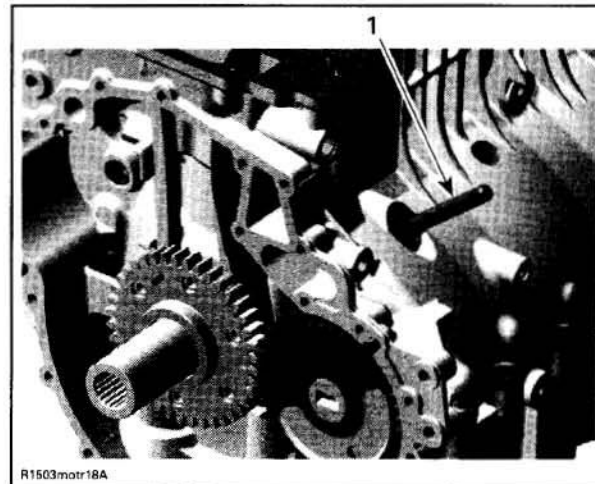
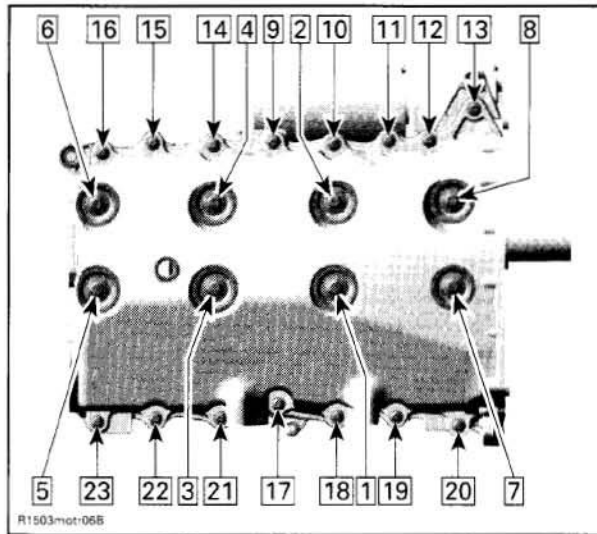

1. Crankshaft locking tool

**NOTE:** Before continuing the assembly process, the axial clearance of balancer shaft and crankshaft has to be checked. Refer to *CRANKSHAFT* and *BALANCER SHAFT* in this section for the procedure.

Install cylinder head, PTO housing and the other parts in accordance with the proper assembly procedures.

Install the crankshaft cover before mounting the engine bracket. Apply oil on O-ring and press cover in. Crankshaft cover has to be flush with cylinder block surface.

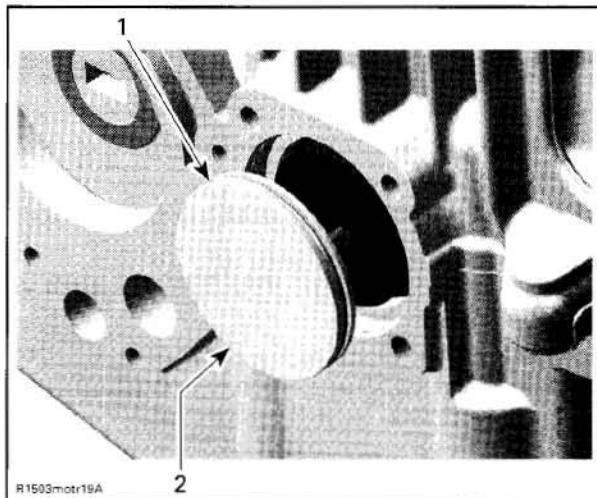

1. O-ring  
2. Crankshaft cover

**CAUTION:** Install crankshaft locking tool (P/N 529 035 821) right away to position crankshaft at TDC before installing the camshaft and rockers (refer to *CYLINDER HEAD*).

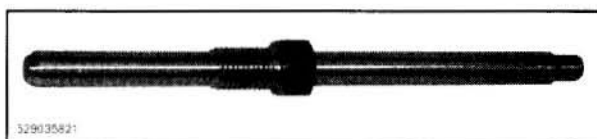



**Section 04 ENGINE MANAGEMENT (1503 4-TEC)**

Subsection 01 (OVERVIEW)

# OVERVIEW

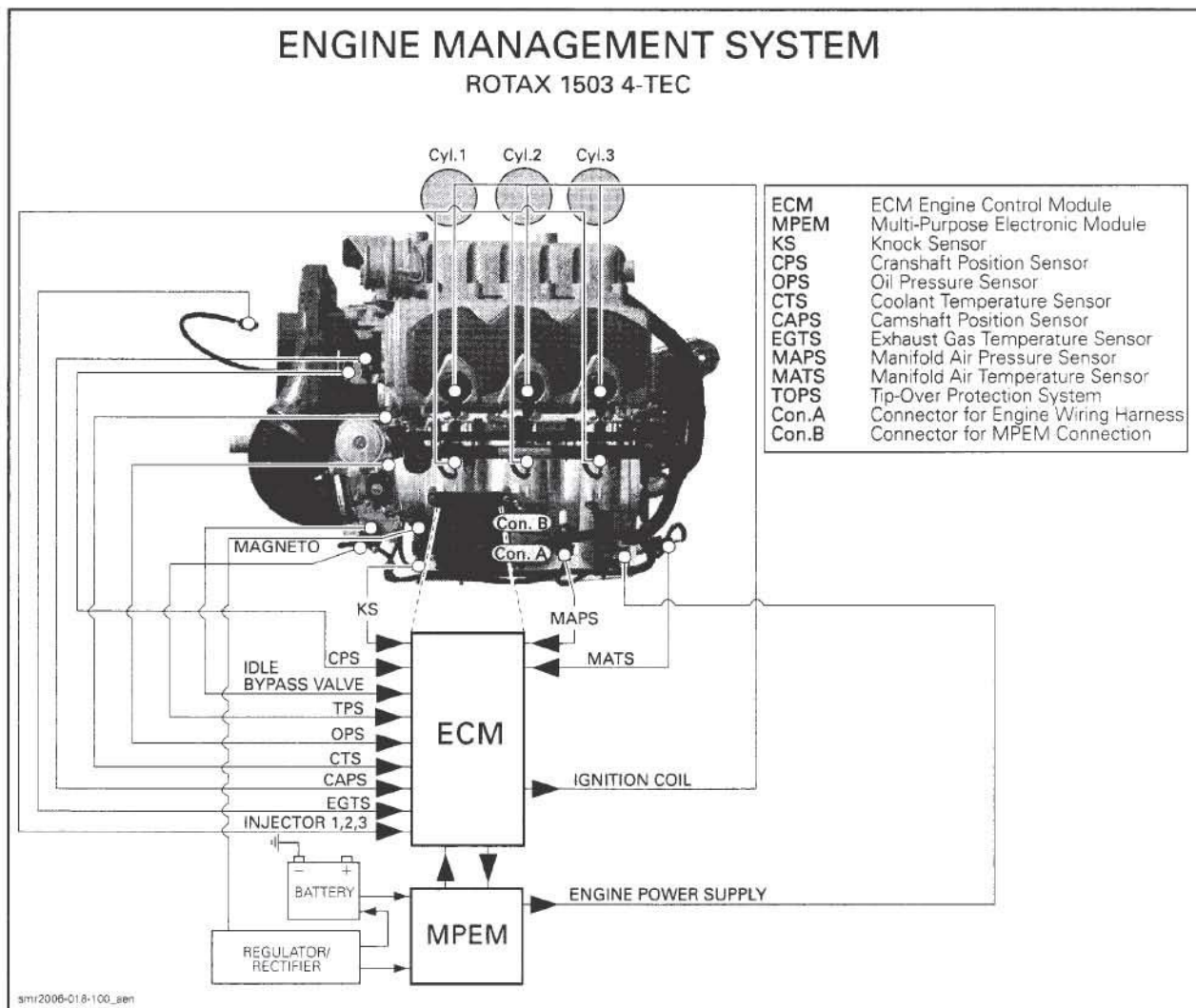



**GENERAL**

There are 3 main systems in interaction with the engine management system:

- 1. air induction system
- 2. fuel delivery system
- 3. electrical system.

**OPERATING PRINCIPLE**

**AIR INDUCTION**

**Throttle Body**

A 52 mm throttle body is mounted on the intake manifold. Fitted on the throttle body, the TPS and the idle bypass valve allow the ECM to control the RPM while the throttle plate is closed.

**4-TEC Naturally-Aspirated Engine**

Air for combustion is drawn directly at the front of the engine through the throttle body. The air flow is controlled by a throttle plate and an idle bypass valve. The air continues through the intake manifold, which contains the flame arrester and goes into the cylinder head.

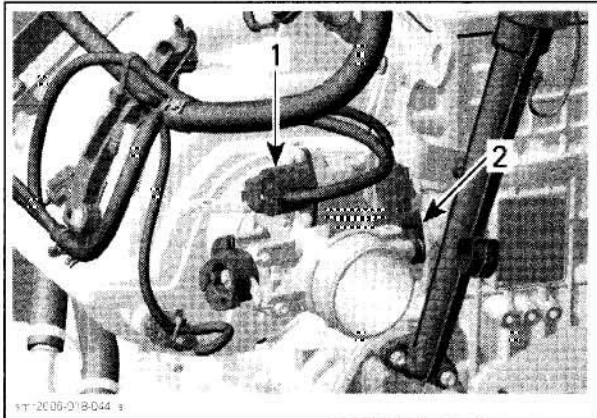

**52 MM THROTTLE BODY**  
1. Idle bypass valve  
2. Throttle position sensor (TPS)

**4-TEC Supercharged Engine**

Air for combustion is drawn at the back of the engine by a mechanically-driven supercharger. The compressed air flows through the throttle body and is controlled by a throttle plate and an idle bypass valve. The air continues through the intake manifold, which contains the flame arrester and goes into the cylinder head.

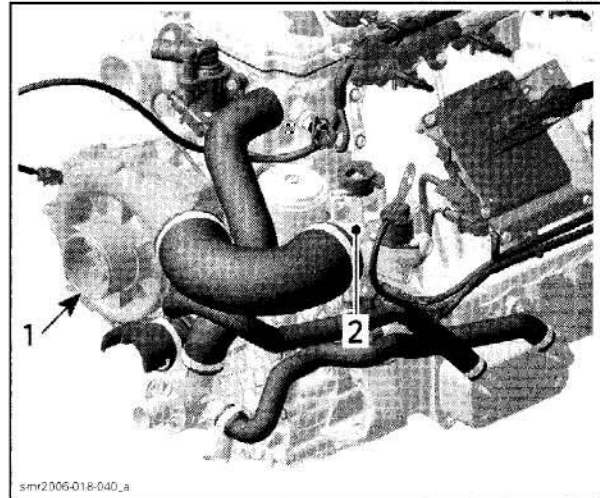

1. Supercharger  
2. Throttle body

**4-TEC Supercharged Intercooled Engine**

Air for combustion is drawn at the back of the engine by a mechanical driven supercharger. The compressed air flows through the throttle body and is controlled by a throttle plate and an idle bypass valve. The air continues through the intake manifold, which contains the water/air intercooler (which cools down the intake air) and goes into the cylinder head.

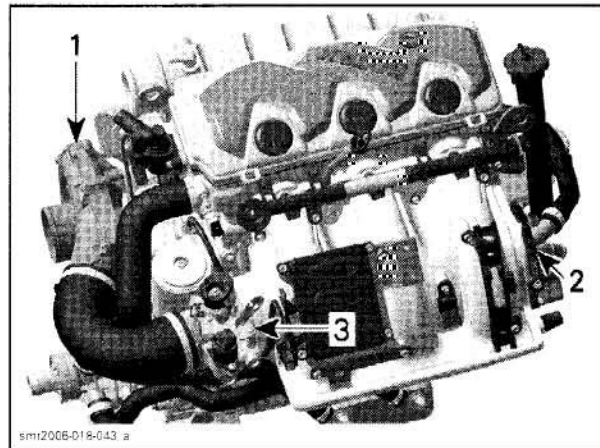

1. Supercharger  
2. Intercooler  
3. Throttle body

**Intake Manifold**

The intake manifold is mounted on the RH side of the cylinder block. It provides support for the fuel injectors, the fuel rail, the ECM, the flame arrester and the throttle body. The intake manifold is a resonator between the throttle body and the cylinder head.



## Section 04 ENGINE MANAGEMENT (1503 4-TEC)

### Subsection 01 (OVERVIEW)

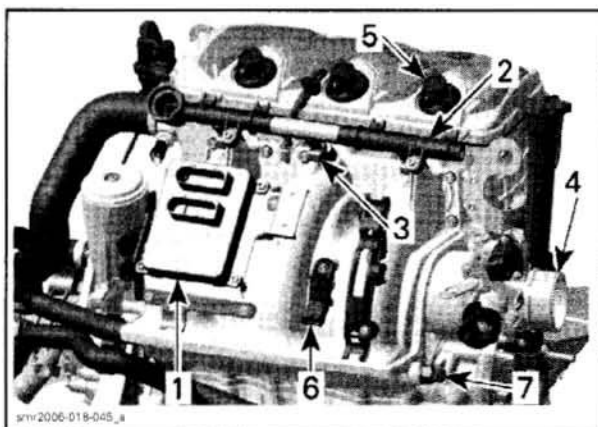

**INTAKE MANIFOLD (4-TEC NATURALLY ASPIRATED)**

1. Engine Control Module (ECM)
2. Fuel rail
3. Injector
4. Throttle body
5. Ignition coil
6. Manifold air pressure sensor (MAPS)
7. Manifold air temperature sensor (MATS)

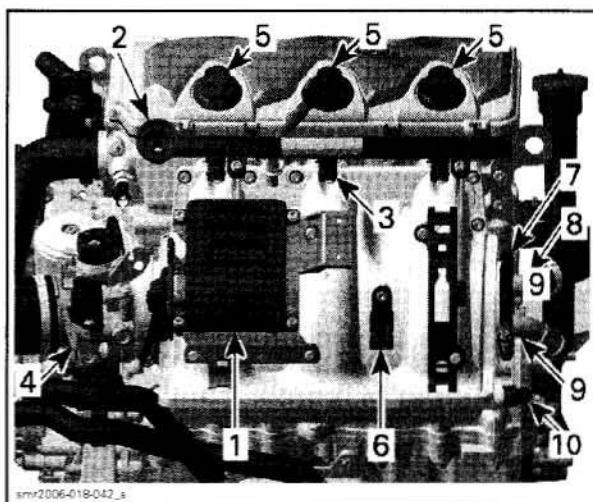

**INTAKE MANIFOLD (4-TEC SUPERCHARGED INTERCOOLED)**

1. Engine Control Module (ECM)
2. Fuel rail
3. Injector
4. Throttle body
5. Ignition coil
6. Manifold air pressure sensor (MAPS)
7. Intercooler
8. Intercooler outlet
9. Intercooler inlet
10. Manifold air temperature sensor (MATS)

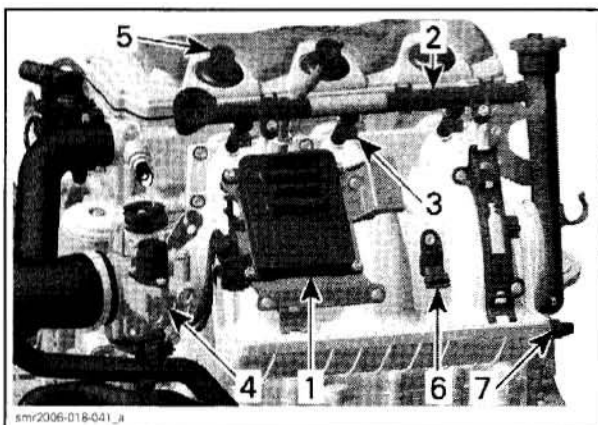

**INTAKE MANIFOLD (4-TEC SUPERCHARGED)**

1. Engine Control Module (ECM)
2. Fuel rail
3. Injector
4. Throttle body
5. Ignition coil
6. Manifold air pressure sensor (MAPS)
7. Manifold air temperature sensor (MATS)

### Flame Arrester

The flame arrester is a tube inside the intake manifold. It prevents flames leaving through the intake system if the engine backfires.

### Intercooler

The intercooler is a tube which comprises smaller tubes. Water taken from the outside of the watercraft is pumped through the smaller tubes and cools down the intake air. Therefore the air density is higher and you get more air into the engine.

## FUEL SYSTEM

When the intake valve reaches the correct position, the ECM (Engine Control Module) opens the fuel injector and fuel is discharged into the intake port at the intake manifold by the high fuel pressure inside the fuel rail. The air/fuel mixture enters then the combustion chamber through the open intake valve. This mixture is then ignited by the spark plug.

### Fuel Rail

The fuel rail is a small tube on which the three injectors are mounted. It ensures all the time, that enough fuel at the right pressure can be delivered to the fuel injectors. The fuel rail is fed by the fuel pump.

#### Fuel Injector

Three fuel injectors (one per cylinder) are used to inject fuel into the intake ports of the cylinder head.

#### Fuel Pump Module

The fuel pump module is located inside the fuel tank. The module includes the fuel pump, fuel pressure regulator and fuel level sensor.

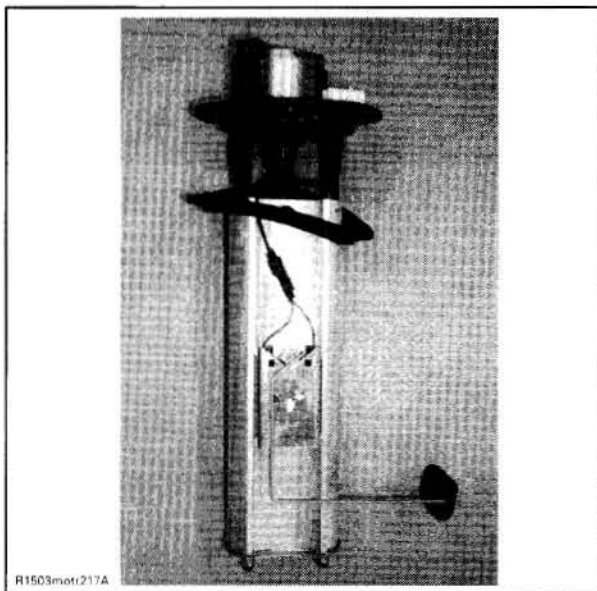

The fuel pump provides fuel pressure and flow rate to the system.

#### Fuel Pressure Regulator

A fuel pressure regulator controls the pressure in the system and allows the excess of fuel to return to the fuel tank. The fuel pressure regulator regulates the fuel pressure within 290 - 310 kPa (42 - 45 PSI) for all 4-TEC Naturally-Aspirated, super-charged engines and at 386 - 414 kPa (56 - 60 PSI) for intercooled engines.

#### Fuel Filter

A mesh filter is located at the bottom of the fuel pump module inside the fuel tank.

## ELECTRICAL SYSTEM

The complete electrical system is managed by micro-controllers working together. Overall, the Multi-Purpose Electronic Module (MPEM) manages the vehicle electrical system, while the engine control module (ECM) is the brain of the engine management system (EMS).

The information center is used to display information that comes both from MPEM and ECM.

A communication link is used between the electronic modules to communicate with each other. It consists of a twisted pair of wires (WHITE/RED and WHITE/BLACK).

For communication link troubleshooting, refer to *GAUGE, SENSORS AND FUSES* in *ELECTRICAL SYSTEM* section.

The communication link is also used to communicate informative messages, monitoring and diagnostic codes to the information center and to B.U.D.S. software (Bombardier utility and diagnostic system) is used for diagnosing and troubleshooting the system.

#### Multi-Purpose Electronic Module (MPEM)

The MPEM distributes power from battery to all accessories and the ECM. Accessories are protected by fuses integrated in the MPEM. Fuse ratings is identified besides their holder.

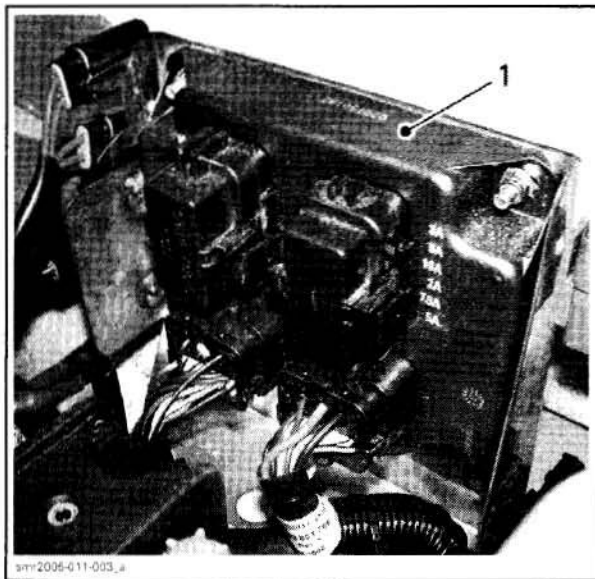

1. MPEM

**IMPORTANT:** Some components are continuously powered with the supply from the battery through the MPEM. The ECM switches the ground to complete the electrical circuits it controls. Take this into account when troubleshooting the electrical system.

#### Gauges Current Supply

When installing the safety lanyard, it activates the reading of gauges without the engine running. It will give access to most functions of the information center gauge without starting the engine.



## Section 04 ENGINE MANAGEMENT (1503 4-TEC)

### Subsection 01 (OVERVIEW)

Gauges are supplied with current whenever the safety lanyard cap is installed on its post.

#### Fuel Pump Current Supply

The fuel pump will be activated for 2 seconds to build up pressure in the fuel injection system, only when connecting the safety lanyard cap to the post.

#### Addition of Electrical Accessories

Every time an accessory is added such as an electric bilge pump or a VTS for instance, it must be "registered" using B.U.D.S. to activate it in the MPEM. Otherwise, the accessory will not work. Use B.U.D.S. Refer to *GAUGE, SENSORS AND FUSES*.

#### Low-Fuel Level Warning Device

When the fuel level in the reservoir is low, the fuel level sensor transmits a signal to the MPEM. The MPEM sends out signals to the beeper and to the information center.

#### ECM (Engine Control Module)

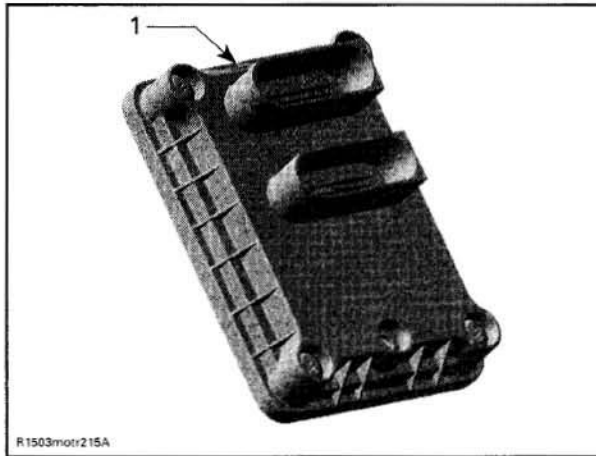

TYPICAL  
1. ECM

The ECM is mounted on the intake manifold. It controls all engine management functions, by processing the information given by various sensors.

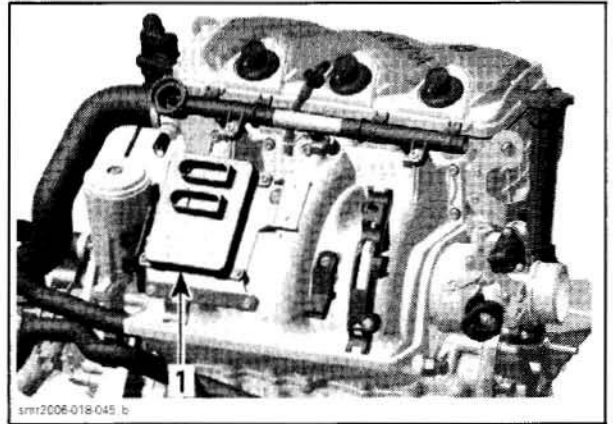

TYPICAL  
1. ECM on intake manifold

The ECM gets its power by the MPEM which is directly powered by the battery. It is responsible for the following engine management/electrical functions:

- interpreting information
- distributing information
- start/stop function
- DESS (Digitally Encoded Security System)
- ignition timing control
- injection control
- engine RPM limiter
- etc.

The ECM also stores the fault codes and general information such as: operating conditions, vehicle hours, serial numbers, customer and maintenance information. The ECM features a permanent memory that will keep these informations, even when the battery is removed from the watercraft.

**Section 04 ENGINE MANAGEMENT (1503 4-TEC)**

Subsection 01 (OVERVIEW)

ECM and MPEM Interaction with the Electrical System

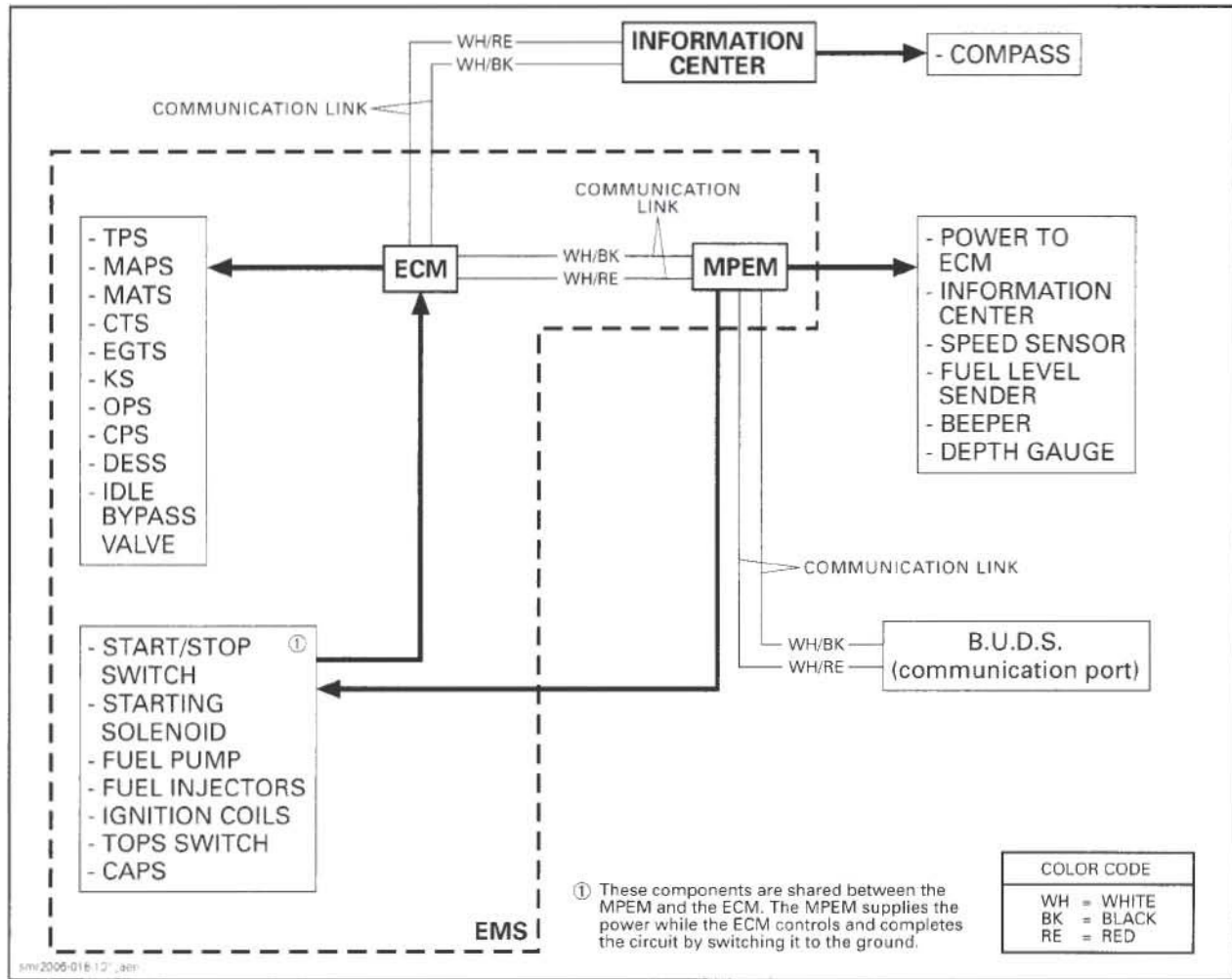



## **ENGINE MANAGEMENT SYSTEM (EMS)**

A highly advanced EMS has been used to ensure a high power output with cleanest combustion.

### **ELECTRONIC FUEL INJECTION**

The ECM reads the signals from different sensors which indicate engine operating conditions at milli-second intervals.

Signals from sensors are used by the ECM to determine the injection parameters (fuel maps) required for optimum air-fuel ratio.

The CPS, the MATS, the MAPS and the TPS are the primary sensors used to control the injection and ignition timing. Other sensors (like temperature sensors, etc.) are used for secondary input.

**NOTE:** The EGTS, CTS and OPS sensors do not provide control inputs to the ECM. Their sole purpose is to protect the engine components by emitting a warning signal in the event of overheating or low oil pressure.

### **IGNITION SYSTEM**

The ignition system is a digital inductive type. The ECM controls the ignition system parameters, such as ignition timing (for each cylinder separately), spark duration and firing order to achieve the proper engine requirements.

#### **Ignition Timing**

The ECM is programmed with data (it contains ignition mappings) for optimum ignition timing under all operating conditions. Using engine operating conditions provided by the sensors, the ECM controls the ignition timing for optimum engine operation. No ignition timing adjustment can be performed.

#### **Ignition Coils**

Three separate ignition coils induce voltage to a high level in the secondary windings to produce a spark at the spark plug.

The ignition coils receive input from the ECM. Each coil provides high voltage to its corresponding spark plug.

This ignition system allows spark plugs to spark independently.

All three ignition coils are located on the cylinder head directly on the spark plugs.

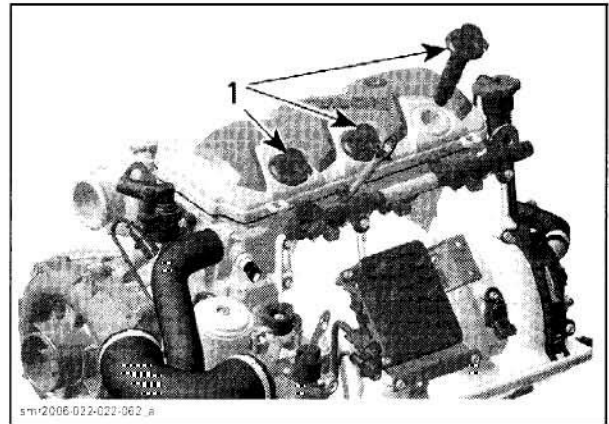

**TYPICAL**  
1. Ignition coils

**NOTE:** To test ignition coils, refer to *IGNITION SYSTEM* subsection.

#### **Knock Sensor**

A knock sensor is mounted on the cylinder block behind the intake manifold. It detects specific vibration that would be typically generated by engine detonation. If detonation occurs, the knock sensor detects it and the ECM retards the ignition advance temporarily (it goes in a specific mode) until detonation stops. The ECM is able to evaluate the knocking cylinder and modifies the ignition advance just on the detonating one.

### **ENGINE MODES OF OPERATION**

The ECM controls different operation modes of the engine to allow proper operation for all possible conditions:

#### **Engine Starting**

If the ECM recognizes a valid safety lanyard, it allows engine to start when the start/stop button is pressed.

If start/stop button is held after engine has started, the ECM automatically stops the starter when the engine speed reaches 1600 RPM.

If start button is activated while the throttle lever is depressed more than 65%, the engine will not be allowed to start.

#### **Engine RPM Limiter**

The ECM will limit the maximum engine speed.

#### **Drowned Mode**

If engine is fuel-flooded and does not start, this special mode can be activated to prevent fuel injection and ignition while cranking. Proceed as follows to activate it.

## Section 04 ENGINE MANAGEMENT (1503 4-TEC)

### Subsection 01 (OVERVIEW)

---

With safety lanyard on its post while engine is stopped, press and HOLD throttle lever.

Press the start/stop button. The mode is now on.

Releasing throttle lever will bring back to its normal mode.

If engine does not start, it may be necessary to remove spark plugs and crank engine with rags over spark plug holes. Refer to *IGNITION SYSTEM* subsection.

#### Limp Home Modes

Besides the signals as seen above, the ECM may automatically use default parameters for the engine management to ensure the adequate operation of the watercraft if a component of the fuel injection system is not operating properly.

The following components failure will trigger a limp home mode: CTS, EGTS and OPS.

When minor fault occurs, the fault and message/beeper will disappear automatically, if the condition does not exist anymore.

Releasing throttle and letting the engine returning at idle speed may allow normal operation to come back. If it does not work, try removing and reinstalling the safety lanyard on its post.

Depending on the malfunction, the watercraft speed may be reduced and not allowed to reach its usual top speed. The engine speed will be limited to 2500 or 5000 RPM.

These performance-reduced modes allow the rider to go back home which would not be possible without this advanced system.

If a fault occurs and involves a limp home mode operation, the engine management system will reduce engine RPM gradually to the required level.

#### MONITORING SYSTEM

The ECM monitors the electronic components of the fuel injection system and also the engine components of the electrical system. When a fault occurs, it sends visual messages through the information center and/or audible signals through a beeper to inform you of a particular condition.

#### Low-Oil Pressure Warning Device

When the oil pressure falls under a certain level, the ECM sends out signals to the beeper and to the information center. Additionally the engine goes in limp home mode.

#### High Coolant Temperature and EGTS Warning Device

When the coolant temperature or the exhaust gas temperature is getting to high, the ECM sends out signals to the beeper and to the information center.

#### DIAGNOSTIC MODE

The malfunctions are recorded in the memory of the ECM. The memory of the ECM can be checked using the B.U.D.S. software to see the fault codes. The ECM and the B.U.D.S. are able to communicate through a connector on the vehicle. Refer to the *EMS DIAGNOSTIC AND COMMUNICATION TOOLS* section.



## Section 04 ENGINE MANAGEMENT (1503 4-TEC)

### Subsection 01 (OVERVIEW)

## ENGINE MANAGEMENT SYSTEM DIAGRAM

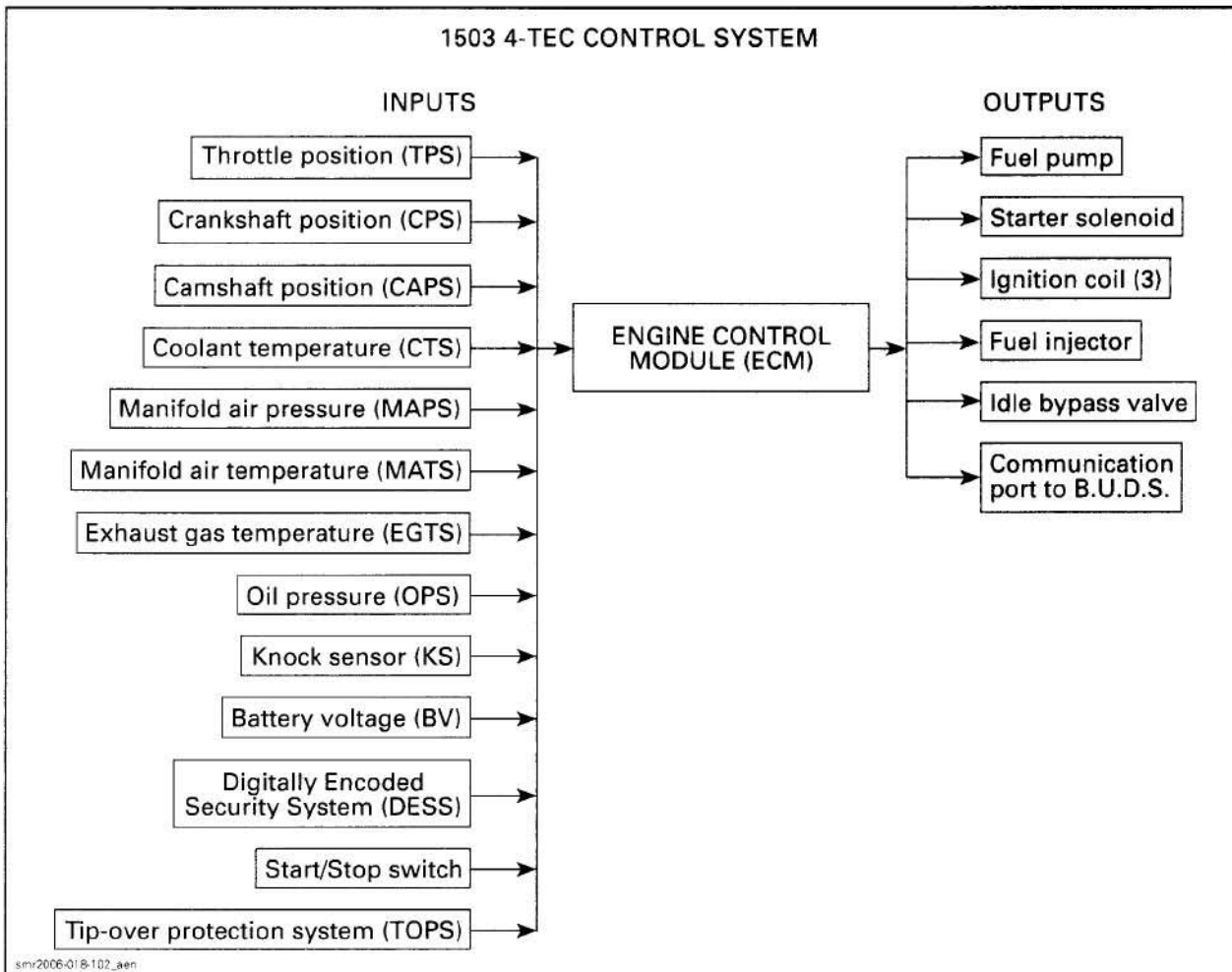

As shown in the 1503 4-TEC CONTROL SYSTEM diagram, the ECM is the central point of the engine management system. It reads the inputs, makes computations, uses pre-determined parameters and sends the proper signals to the outputs for proper engine management.

# EMS DIAGNOSTIC AND COMMUNICATION TOOLS

## SERVICE TOOLS

Description	Part Number	Page
Communication kit.....	529 035 981 .....	179
DESS post interface .....	529 036 019 .....	181
Diagnostic cable .....	710 000 851 .....	181
MPI-2.....	529 036 018 .....	181
Optional extension cable .....	529 035 697 .....	181
Optional extension cable .....	529 035 703 .....	179

## GENERAL

Here is the basic order suggested to diagnose a suspected engine management or fuel injection related problem.

- Check the *TROUBLESHOOTING* section to have an overview of problems and suggested solutions.
- Check if there is a message displayed by the vehicle information center. If so, use B.U.D.S. software and look for fault codes to diagnose the trouble.

**NOTE:** Fault codes, the letter P — followed by 4 digits (P-1234), are displayed in the information center for troubleshooting.

- Check all fuses.
- Check fuel pressure.
- Check spark plugs condition.
- Check fuel pump pressure.
- Check all connections of the wiring harness.
- Refer to *ADJUSTMENT AND REPAIR PROCEDURES*.

## Terminology

Some documents or softwares use technical terms that may be different from the one used in this manual. The following table will help to find the equivalence.

TERMS USED IN THIS MANUAL	TERMS USED IN OTHER DOCUMENTS SOFTWARES
Camshaft	Cam
Communication link	CAN
Crankshaft	Crank
CTS (Coolant Temperature Sensor)	WTS (Water Temperature Sensor)
ECM	- ECU - Module
EGTS (Exhaust Gas Temperature sensor)	ETS (Exhaust Temperature Sensor)
Idle bypass valve	- DLA (Digital Linear Actuator) - Idle actuator - Idle air control valve - Idle valve
Information center	Cluster
MAPS (Manifold Air Pressure Sensor)	APS (Air Pressure Sensor) or (Atmospheric Pressure Sensor)
MATS (Manifold Air Temperature Sensor)	ATS (Air Temperature Sensor) or (Intake manifold Temperature Sensor)



## Section 04 ENGINE MANAGEMENT (1503 4-TEC)

### Subsection 02 (EMS DIAGNOSTIC AND COMMUNICATION TOOLS)

## DIAGNOSTIC

### MONITORING SYSTEM

When one of the below conditions occurs, the monitoring system emits the following beep signals.

CODED SIGNALS	POSSIBLE CAUSE	REMEDY
2 short beeps (while installing DESS key on post).	<ul style="list-style-type: none"><li>- Confirms key signal operation.</li><li>- Key is recognized by the ECM.</li><li>- Good contact between key and DESS post.</li></ul>	<ul style="list-style-type: none"><li>- Engine can be started.</li></ul>
1 long beep (while installing key on post).	<ul style="list-style-type: none"><li>- Bad DESS system connection.</li><li>- Wrong key.</li><li>- Defective key.</li><li>- Dried salt water or dirt in key.</li><li>- Defective DESS post.</li><li>- Improper operation of ECM or defective wiring harness.</li></ul>	<ul style="list-style-type: none"><li>- Reinstall key correctly over post.</li><li>- Use a key that has been programmed for the watercraft. If it does not work, check key with B.U.D.S. Replace key if defective.</li><li>- Use another programmed key.</li><li>- Clean key to remove salt water.</li><li>- Refer to <i>DESS</i> section.</li><li>- Refer to <i>ADJUSTMENT AND REPAIR</i> section.</li></ul>
4 short beeps every 3 seconds interval.	<ul style="list-style-type: none"><li>- DESS key has been left on its post without starting engine or after engine was stopped.</li></ul>	<ul style="list-style-type: none"><li>- To prevent battery discharge, remove the key from its post.</li></ul>
2 seconds beep every 15 minutes interval.	<ul style="list-style-type: none"><li>- Watercraft is upside down.</li><li>- Wrong information center installed.</li><li>- Battery voltage too low.</li><li>- Engine coolant temperature sensor or circuit malfunction.</li><li>- Exhaust temperature sensor or circuit malfunction.</li><li>- Engine oil pressure sensor or circuit malfunction.</li><li>- TOPS, MAP, CPS, TPS, or knock sensor or circuit malfunction.</li><li>- Fuel injector or circuit malfunction.</li><li>- Ignition coil or circuit malfunction.</li><li>- Fuel pump or circuit malfunction.</li><li>- Starter solenoid circuit malfunction.</li></ul>	<ul style="list-style-type: none"><li>- Turn watercraft upright. If it does not work, check the TOPS switch. Refer to <i>ADJUSTMENT AND REPAIR</i> section.</li><li>- Refer to <i>GAUGE, SENSORS AND FUSES</i>.</li><li>- Refer to <i>CHARGING SYSTEM</i> section.</li><li>- Refer to <i>ADJUSTMENT AND REPAIR</i> section.</li><li>- Refer to <i>ADJUSTMENT AND REPAIR</i> section.</li><li>- Refer to <i>ADJUSTMENT AND REPAIR</i> section.</li><li>- Refer to <i>ADJUSTMENT AND REPAIR</i> section.</li><li>- Refer to <i>ADJUSTMENT AND REPAIR</i> section.</li><li>- Refer to <i>IGNITION SYSTEM</i> section.</li><li>- Refer to <i>FUEL SYSTEM</i> section.</li><li>- Refer to <i>STARTING SYSTEM</i> section.</li></ul>
A 2 seconds beep every 5 minutes interval.	<ul style="list-style-type: none"><li>- Low fuel level.</li><li>- Fuel tank level sensor or circuit malfunction.</li></ul>	<ul style="list-style-type: none"><li>- Refer to <i>GAUGE, SENSORS AND FUSES</i> section.</li><li>- Refer to <i>GAUGE, SENSORS AND FUSES</i> section.</li></ul>
Continuously beeps.	<ul style="list-style-type: none"><li>- High engine coolant temperature.</li><li>- High exhaust temperature.</li><li>- Low engine oil pressure.</li></ul>	<ul style="list-style-type: none"><li>- Refer to <i>COOLING SYSTEM</i> section.</li><li>- Refer to <i>EXHAUST SYSTEM</i> section.</li><li>- Refer to <i>LUBRICATION SYSTEM</i> section.</li></ul>

**Section 04 ENGINE MANAGEMENT (1503 4-TEC)**  
**Subsection 02 (EMS DIAGNOSTIC AND COMMUNICATION TOOLS)**

## FAULT CODES

### General

The faults registered in the MPEM/ECM are kept when the battery is disconnected.

**IMPORTANT:** After a problem has been solved, ensure to clear the fault(s) in the MPEM/ECM using the B.U.D.S. software. This will properly reset the appropriate counter(s). This will also records that the problem has been fixed in the MPEM/ECM memory.

Many fault codes at the same time is likely to be burnt fuse(s).

For more information pertaining to the code faults (state, count, first, etc.) and report, refer to B.U.D.S. online help.

When using the service action suggested in the Fault section of B.U.D.S., the system circuits are referred as 4-23 for instance. It means Amp connector no. 4 and the circuit wire no. 23 as found in the wiring diagram.

When they are referred as A-41, it means connector "A" on the ECM and the circuit 41.

### TPS (Throttle Position Sensor) Faults

Faults which are reported in B.U.D.S. fall into two groups: TPS faults and adaptation faults. These are displayed on the B.U.D.S. system as TPS OUT OF RANGE and TPS ADAPTATION FAILURE.

#### TPS "OUT OF RANGE" Fault

It is caused by the sensor reading going out of its allowable range. This fault can occur during the whole range of movement of the throttle.

To diagnose this fully, it is recommended to operate the throttle through its full range. It is also recommended to release the throttle quickly as this may also show up a fault that is intermittent.

POSSIBLE CAUSES	ACTION
Check if connector is disconnected from TPS.	Fix.
Check if sensor is loose.	Fix and reset Closed Throttle and Idle Actuator.
Inspect sensor for damage or corrosion.	Replace and reset Closed Throttle and Idle Actuator.
Inspect wiring (voltage test).	Repair.
Inspect wiring and sensor (resistance test).	<ul style="list-style-type: none"> <li>- If bad wiring, repair.</li> <li>- If bad TPS, replace and reset Closed Throttle and Idle Actuator.</li> </ul>
Test sensor operation (wear test).	Replace and reset Closed Throttle and Idle Actuator.

#### TPS "ADAPTATION FAILURE" Fault

It is caused by the idle position moving out of an acceptable range.

Following failures can be effected by a TPS "Adaptation Failure":

- Idle speed is out of range.
- Engine stops, when throttle is released quickly.
- Engine runs inconsistent in low partload or low RPM.

POSSIBLE CAUSES	ACTION
Sensor has been replaced and TPS closed position not reset.	Reset Closed Throttle and Idle Actuator.
Throttle body has been replaced and TPS closed position not reset.	Reset Closed Throttle and Idle Actuator.
ECM has been replaced and TPS closed position not reset.	Reset Closed Throttle and Idle Actuator.
Throttle cable too tight.	Fix and reset Closed Throttle and Idle Actuator.
Sensor is loose.	Fix and reset Closed Throttle and Idle Actuator.
Throttle bracket is loose.	Fix and reset Closed Throttle and Idle Actuator.
Adjustment screw worn or loose.	Change throttle body.



### Supplemental Information for Some Specific Faults

**Communication link fault code 1681:** Sometimes the information center does not synchronize fast enough for the MPEM. That brings this fault code. Simply clear the fault and try again.

**ECM fault codes P0601, P0602, P0604 and P605:** These codes may occur in the following situations:

- Electrical noise is picked up by the ECM. Ensure that all connections are in good condition, also grounds (battery, ECM, engine and ignition system), they are clean and well tightened and that all electronic components are genuine – particularly in the ignition system. Installing resistive caps, non-resistive spark plugs or improper knock sensor wiring/routing may lead to generate this fault code.
- Electrical noise might also lead engine to occasional cutout without generating a fault code when engine is restarted. When looking at the fault code, pay attention to the "count" value in the software B.U.D.S. A value between 1 and 9 confirms an electrical noise problem. A value of 10 and above will generate a fault code.
- When installing a new ECM. It is not properly programmed from the factory. The ECM must be returned to be properly "activated".
- If everything is in good condition, try a new ECM.

**Fault code P1513:** Wrong ECM or information center. Installed part is not appropriate for the vehicle. Engine will crank but will not start. Refer to parts catalogs for proper part according to vehicle.



**Section 04 ENGINE MANAGEMENT (1503 4-TEC)**  
**Subsection 02 (EMS DIAGNOSTIC AND COMMUNICATION TOOLS)**

**COMMUNICATION TOOLS**

Two different MPI (Multi Purpose Interface) can be used with B.U.D.S. software: MPI and MPI-2. Refer to the following for proper connections.

**NOTE:** The MPEM programmer does not work on 4-TEC models.

**MPI (Multi-Purpose Interface)**

PART REQUIRED	OPERATION TO PERFORM
	ALL
PC computer	X
B.U.D.S. software Use latest version available on BOSSWeb	X
Communication kit (P/N 529 035 981) 	X
Optional extension cable (P/N 529 035 703) 	X

**MPI Supply**

The MPI can use the vehicle power for its supply. Four AA batteries or an AC/DC power supply can also be used. Make sure to respect MPI specification if a power supply is used.

**Connections with Vehicle**

**⚠ WARNING**

If the computer you are using is connected to the power outlet, there is a potential risk of electrocution when working in contact with water. Be careful not to touch water while working with the computer.

Remove protective cap from the 6-pin connector. Connect the 6-pin adapter to the vehicle connector.

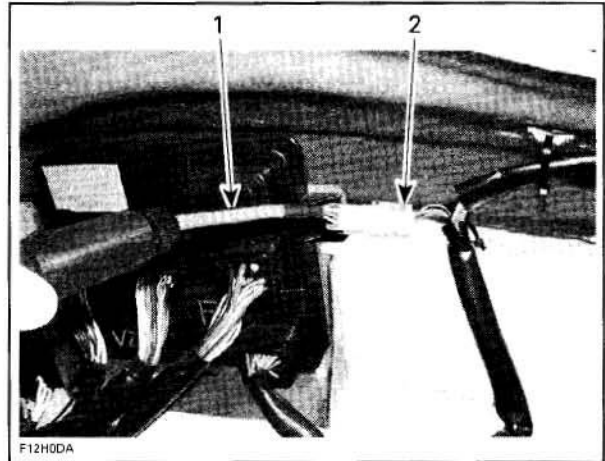

**TYPICAL**  
 1. 6-pin adapter  
 2. Connector close to MPEM

Connect the diagnostic cable to the 6-pin adapter.

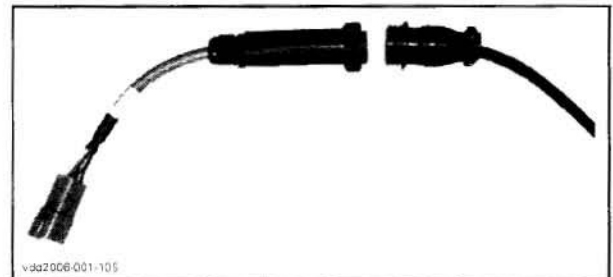

Connect the other diagnostic cable connector to MPI connector.

Connect serial cable to MPI connector.





---

## Section 04 ENGINE MANAGEMENT (1503 4-TEC)

### Subsection 02 (EMS DIAGNOSTIC AND COMMUNICATION TOOLS)

---

Connect remaining serial cable connector to the serial port of a PC (personal computer).

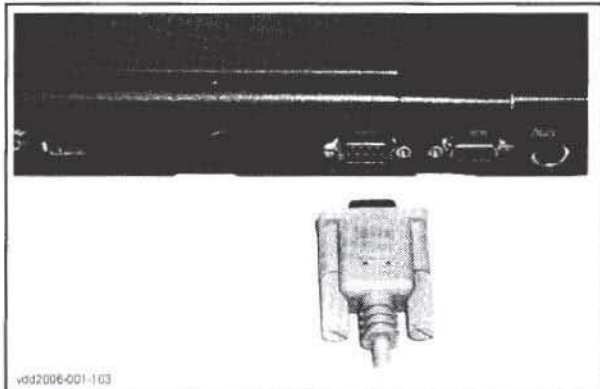

Use B.U.D.S. software as described further in *B.U.D.S. SOFTWARE*.

**Section 04 ENGINE MANAGEMENT (1503 4-TEC)**  
**Subsection 02 (EMS DIAGNOSTIC AND COMMUNICATION TOOLS)**

**MPI-2 (Multi-Purpose Interface)**

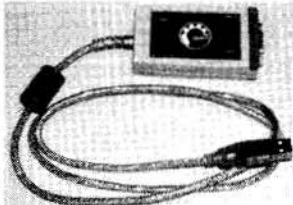
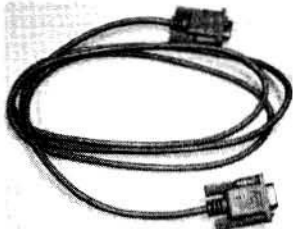
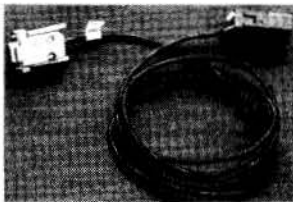
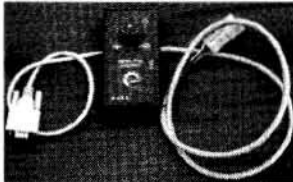
PART REQUIRED	OPERATION	
	- PROGRAMMING KEY(S)	- ENTERING CUSTOMER INFORMATION - SETTING IGNITION TIMING/CLOSED TPS - READING FAULT CODES - ACTIVATION OF COMPONENTS (IGNITION COIL, FUEL PUMP ETC.)
PC computer	X	X
B.U.D.S. software Use latest version available on BOSSWeb	X	X
MPI-2 (P/N 529 036 018) 	X	X
Optional extension cable (P/N 529 035 697) 	X	X
Diagnostic cable (P/N 710 000 851) 	X	X
DESS post interface (P/N 529 036 019) 	X	



### MPI-2 Supply

The MPI can use the vehicle power for its supply. Two AA batteries or an AC/DC power supply can also be used. Make sure to respect MPI-2 specification if a power supply is used.

### Connections with Vehicle

**⚠ WARNING**

If the computer you are using is connected to the power outlet, there is a potential risk of electrocution when working in contact with water. Be careful not to touch water while working with the computer.

Remove protective cap from the 6-pin connector.

**NOTE:** To program key(s), install DESS post interface between vehicle 6-pin connector and MPI-2. You can leave post interface connected for all operations you do with B.U.D.S.

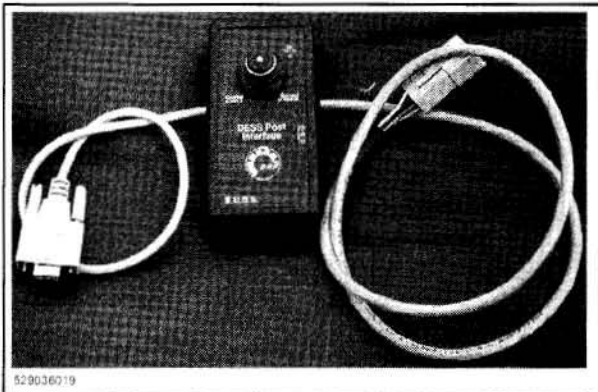

Connect diagnostic cable to vehicle connector.



Connect remaining connector to MPI-2 connector.

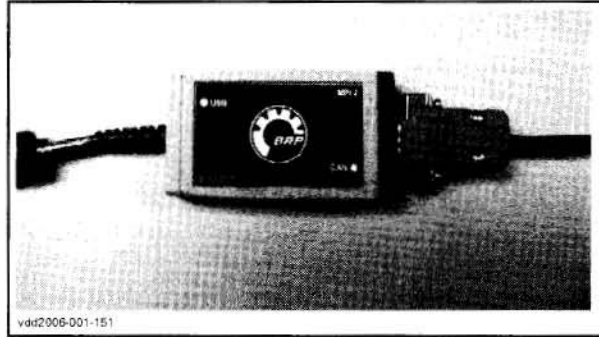

Connect remaining MPI-2 connector to the USB port of a PC (personal computer).

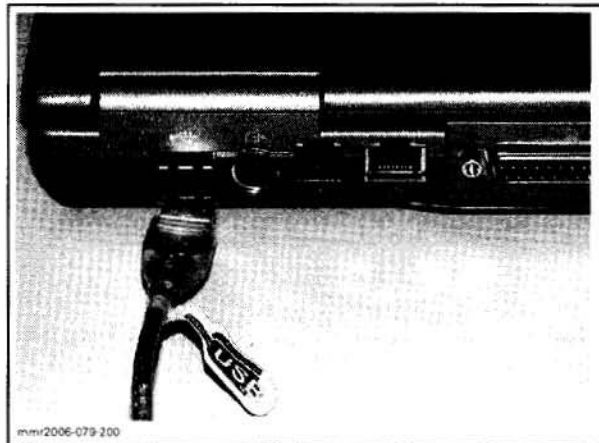

Use B.U.D.S. software as described further in *B.U.D.S. SOFTWARE*.

### B.U.D.S. SOFTWARE

B.U.D.S. (Bombardier Utility and Diagnostic Software) is designed to program key(s), to allow electrical component inspection, diagnostic options and adjustments such as the closed throttle.

For more information pertaining to the use of the B.U.D.S. software, use its help which contains detailed information on its functions.

When using the service action suggested in the Fault section of B.U.D.S., for instance, a system circuit referred to as A-35, means connector "A" on the ECM and the contact 35.

Ensure to use the latest B.U.D.S. version available on BossWeb.

When using the B.U.D.S. software:

- Connect key to vehicle DESS post to activate the communication.
- Ensure that 115200 speed is properly selected in "MPI" under "Choose speed".

---

## Section 04 ENGINE MANAGEMENT (1503 4-TEC)

### Subsection 02 (EMS DIAGNOSTIC AND COMMUNICATION TOOLS)

---

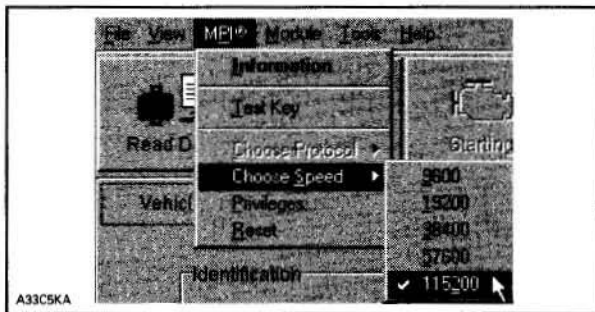

### Changes in ECM

Anytime a change is brought in ECM through B.U.D.S., there will be an "EMS Tracking" message that will say "Remove key from vehicle". When this occurs, remove the DESS key from its post and wait until the message disappears (it lasts approximately 15 seconds after key removal).

**NOTE:** If you are using an old PC computer, it may be necessary to use a slower speed so that the communication works.

- Ensure that the protocol "Kw2000" is properly selected in "MPI" under "Choose protocol."

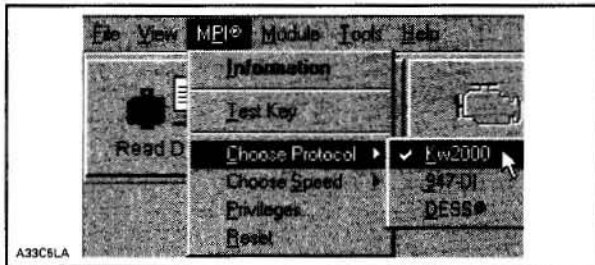

- Ensure the status bar shows the Kw2000 and the number 3 to the right.

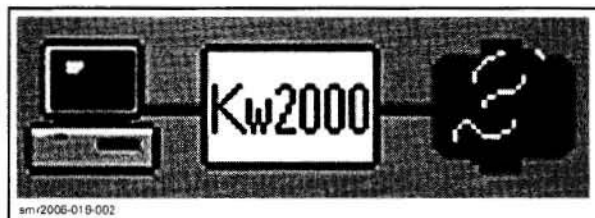

**CONNECTION SUCCESSFUL**

Number 3 means that 3 "ECUs" are connected (Information center, MPEM and ECM).

If an "X" is shown, the DESS key is not installed on its post or there is a problem with all "ECUs". Ensure B.U.D.S. is working properly and check connections on MPI and watercraft.

- information center, MPEM or ECM is not powered-up
- wrong protocol is used
- bad connection between MPI and MPEM.



# ADJUSTMENT AND REPAIR PROCEDURES

## SERVICE TOOLS

Description	Part Number	Page
ECM adapter.....	420 277 010 .....	188
Fluke 111 .....	529 035 868 .....	187
fuel hose disconnect tool .....	529 036 037 .....	195
tachometer .....	529 014 500 .....	191

## SERVICE PRODUCTS

Description	Part Number	Page
Loctite 243 .....	293 800 060 .....	200

## GENERAL

Engine problems are not necessarily related to the engine management system.

It is important to ensure that the mechanical integrity of the engine/propulsion system is present:

- good jet pump/drive system operation
- good engine compression and properly operating mechanical components, no leaks etc.
- fuel pump connection and fuel lines without leaks.

Check the chart in *TROUBLESHOOTING* section to have an overview of problems and suggested solutions.

When replacing a component, always check its operation after installation.

Whenever watercraft is out of water and engine is running, ensure to supply water through the connector on jet pump support to cool down exhaust system.

**CAUTION:** Never run engine without supplying water to the exhaust system when watercraft is out of water.

## FUEL SYSTEM

**⚠ WARNING**

The fuel system of a fuel injection system holds much more pressure than on a carbureted watercraft. Prior to disconnecting a hose or to removing a component from the fuel system, follow the recommendation described here. Note that some hoses may have more than one clamp at their ends. Ensure to reinstall the same quantity of clamps at assembly.

Use the B.U.D.S. software to release the fuel pressure in the system. Look in the **Activation** tab.

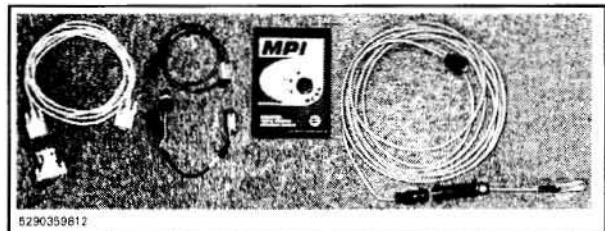



## Section 04 ENGINE MANAGEMENT (1503 4-TEC)

### Subsection 03 (ADJUSTMENT AND REPAIR PROCEDURES)

#### WARNING

Fuel lines remain under pressure at all times. Always proceed with care and use appropriate safety equipment when working on pressurized fuel system. Wear safety glasses. Do not allow fuel to spill on hot engine parts and/or on electrical connectors. Proceed with care when removing/installing high pressure test equipment or disconnecting fuel line connections. Use the B.U.D.S. software to release fuel pressure prior to removing a hose. Cover the fuel line connection with an absorbent shop rag. Slowly disconnect the fuel hose to minimize spilling. Wipe off any fuel spillage in the bilge. Fuel is flammable and explosive under certain conditions. Always work in a well ventilated area. Always disconnect battery prior to working on the fuel system. After performing a pressure test, use the valve on the fuel pressure gauge to release the pressure (if so equipped).

Always disconnect battery properly prior to working on the fuel system. Refer to *CHARGING SYSTEM* section.

When the job is done, ensure that hoses from fuel rail going to fuel pump are properly secured in their supports. Then, pressurize the fuel system. Perform the high pressure test as explained in this section and pressurize the fuel separator and fuel lines as explained in *FUEL SYSTEM* section.

Properly reconnect the battery.

#### WARNING

Ensure to verify fuel line connections for damage and that NO fuel line is disconnected prior to installing the safety lanyard on the DESS post. Always perform the high pressure test if any component has been removed. A pressure test must be done before connecting the safety lanyard. The fuel pump is started each time the safety lanyard is installed and it builds pressure very quickly.

To check fuel rail for leaks, first pressurize the system then spray soapy water on all hose connections, regulators and injectors. Air bubbles will show the leaking area. Check also for leaking fuel or fuel odor.

#### WARNING

If any gasoline leak and/or odor are present, do not start the engine. Repair the leak.

#### WARNING

Never use a hose pincher on high pressure hoses.

### Fuel Rail

Pressure at fuel rail is supplied and controlled by the fuel pump module. Refer to *FUEL TANK AND FUEL PUMP* subsection for pressure test.

There is a valve on fuel inlet hose connected to the fuel rail. This valve is for manufacturing purpose only.

#### WARNING

**PRESSURIZED FUEL.** Do not unscrew protective cap. Do not operate the watercraft without cap properly installed.

### Fuel Rail Replacement

Refer to *FUEL INJECTOR* in this section.

### Fuel Pump

Refer to *FUEL SYSTEM* section.

## ELECTRICAL SYSTEM

It is important to check that the following electrical system components are functioning properly:

- battery
- fuses
- DESS
- ignition (spark)
- ground connections
- wiring connectors.

It is possible that a component seems to operate in static condition but in fact, it is defective. In this case, the best way to solve this problem is to remove the original part and replace it with one which is in good condition.

Never use a battery charger to substitute temporarily the battery, as it may cause the MP/ECM to work erratically or not to work at all. Check related-circuit fuse solidity and condition with an ohmmeter. Visual inspection could lead to false results.

**Section 04 ENGINE MANAGEMENT (1503 4-TEC)**  
**Subsection 03 (ADJUSTMENT AND REPAIR PROCEDURES)**

**⚠ WARNING**  
 All electrical actuators (idle bypass valve, injectors, fuel pump, ignition coils and starter solenoid) are permanently supplied by the battery when the safety lanyard is installed. Always disconnect the battery prior to disconnecting any electrical or electronic parts.

To perform verifications, a good quality multimeter such as Fluke 111 (P/N 529 035 868) should be used.



Pay particular attention to ensure that terminals are not out of their connectors or out of shape. The troubleshooting procedures cover problems not resulting from one of these causes.

**⚠ WARNING**  
 Ensure all terminals are properly crimped on wires and connector are properly fastened.

Before replacing a MPEM or ECM, always check electrical connections. Make sure that they are very tight and they make good contact and that they are corrosion-free. Check if wiring harness shows any signs of scoring. Particularly check MPEM and ECM ground connections. Ensure that contacts are good and clean. A "defective module" could possibly be repaired simply by unplugging and replugging the MPEM or ECM. The voltage and current might be too weak to go through dirty wire terminals. Check carefully if terminals show signs of moisture, corrosion or if they look dull. Clean terminals properly and then coat them prior to assembling as follows:

**NOTE:** Do not apply dielectric grease or any other lubricant on the ECM or MPEM connectors.

Other connectors: Apply a silicon-based dielectric grease or other appropriate lubricant. If the newly replaced MPEM or ECM is working, try the old one and recheck if it works.

Ensure that all electronic components are genuine — any modification on the wiring harness may lead to generate fault codes or bad operation.

**NOTE:** For diagnostics purposes, use B.U.D.S. software. See *EMS DIAGNOSTIC AND COMMUNICATION TOOLS* subsection.

After a problem has been solved, ensure to clear the fault(s) in the ECM using the B.U.D.S. software.

**Sensor Resistance Measurement**

When measuring the resistance with an ohmmeter, all values are given for a temperature of 20°C (69°F). The value of a resistance varies with the temperature. The resistance value for usual resistor or windings (such as injectors) **increases** as the temperature increases. However, our temperature sensors are NTC types (Negative Temperature Coefficient) and work the opposite which means that the resistance value **decreases** as the temperature increases. Take it into account when measuring at temperatures different from 20°C (69°F). Use this table for resistance variation relative to temperature for temperature sensors.

TEMPERATURE		RESISTANCE (OHMS)		
°C	°F	NOMINAL	LOW	HIGH
- 30	- 22	12600	11800	13400
- 20	- 4	11400	11000	11800
- 10	14	9500	8000	11,000
0	32	5900	4900	6900
10	50	3800	3100	4500
20	68	2500	2200	2800
30	86	1700	1500	1900
40	104	1200	1080	1320
50	122	840	750	930
60	140	630	510	750
70	158	440	370	510
80	176	325	280	370
90	194	245	210	280
100	212	195	160	210
110	230	145	125	160
120	248	115	100	125

CONVERSION CHART FOR TEMPERATURE SENSORS



**Section 04 ENGINE MANAGEMENT (1503 4-TEC)**  
**Subsection 03 (ADJUSTMENT AND REPAIR PROCEDURES)**

The resistance value of a temperature sensor may test good at a certain temperature but it might be defective at other temperatures. If in doubt, try a new sensor.

Also remember this validates the operation of the sensor at ambient temperature. It does not validate the over temperature functionality. To test it, the sensor could be removed from the engine/muffler and heated with a heat gun while it is still connected to the harness to see if the ECM will detect the high temperature condition and generate a fault code.

**NOTE:** In case of overheating, EGTS and CTS do not generate fault codes. A message will be displayed on the information center, the beeper will be activated and the EMS will be set in limp home mode.

**ECM Connectors**

The most recommended and safest method to probe ECM connector terminals is to use the ECM adapter (P/N 420 277 010). This tool will prevent deforming or enlarging terminals which would lead to bad ECM terminal contact creating intermittent or permanent problems.

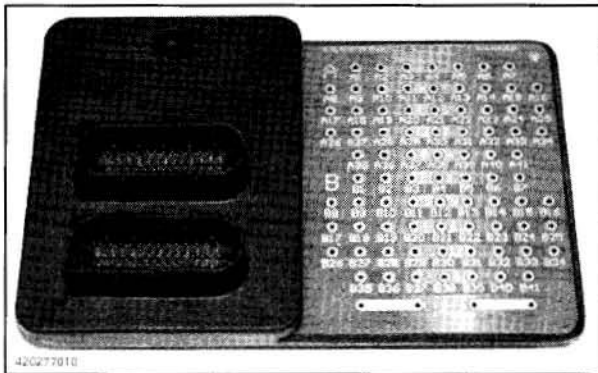

Disconnect the desired connector from ECM and reconnect on the tool connector. Probe required terminals directly in the tool holes.

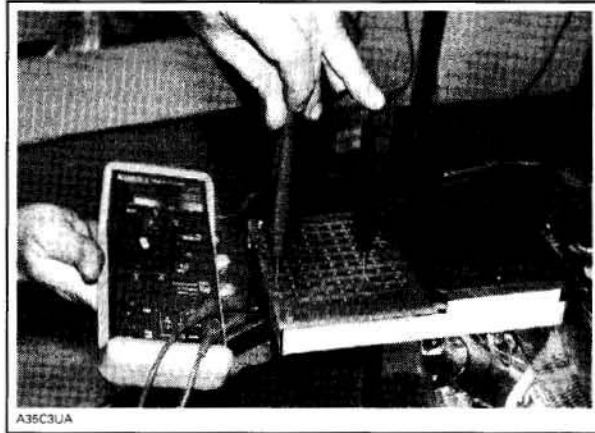

**CAUTION:** If not using the ECM adapter, probe on top of terminal only. Do not try to probe inside terminal or to use a paper clip to probe inside terminal, it will damage the square-shaped terminal and this could lead to improper function of the engine management system.

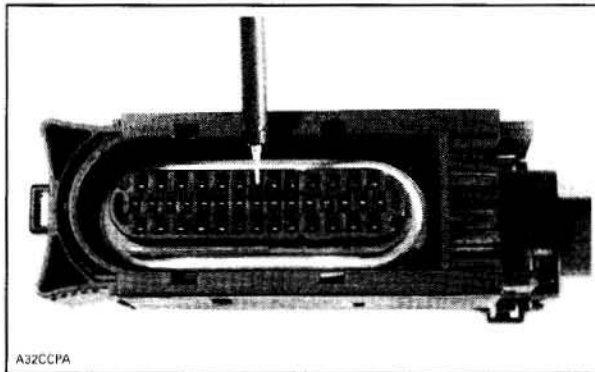

PROBE ONLY TOP OF TERMINAL

Use this diagram to locate the terminal numbers on the ECM connector "A" of the wiring harness when performing tests.

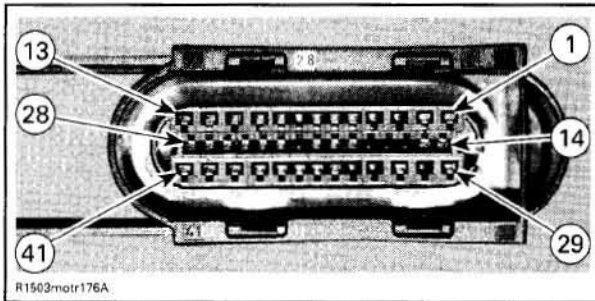

TERMINAL IDENTIFICATION OF ECM CONNECTOR "A" (WIRING HARNESS SIDE)

**CAUTION:** Do not disconnect the ECM connectors needlessly. They are not designed to be disconnected/reconnected repeatedly.



## Section 04 ENGINE MANAGEMENT (1503 4-TEC)

### Subsection 03 (ADJUSTMENT AND REPAIR PROCEDURES)

**NOTE:** For more details on ECM connectors servicing, refer to *ELECTRICAL CONNECTORS AND WIRING DIAGRAM* section.

#### Engine Wiring Harness

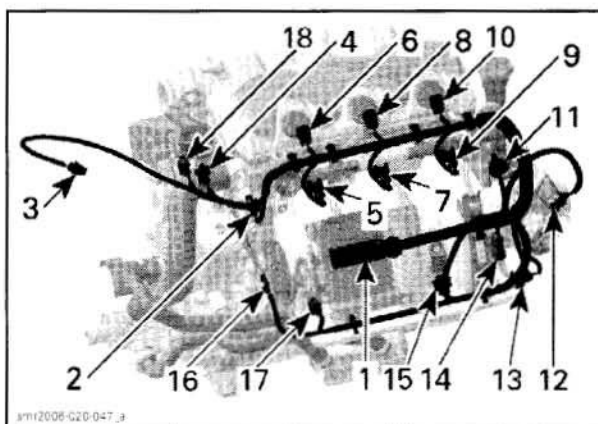

#### 4-TEC NATURALLY ASPIRATED ENGINES

1. ECM connector
2. CTS connector
3. EGTS connector
4. CAPS connector
5. Fuel injector connector (cylinder 1)
6. Ignition coil connector (cylinder 1)
7. Fuel injector connector (cylinder 2)
8. Ignition coil connector (cylinder 2)
9. Fuel injector connector (cylinder 3)
10. Ignition coil connector (cylinder 3)
11. TPS connector
12. Idle bypass valve connector
13. MATS connector
14. Engine connector
15. MAPS connector
16. OPS connector
17. KS connector
18. CPS connector

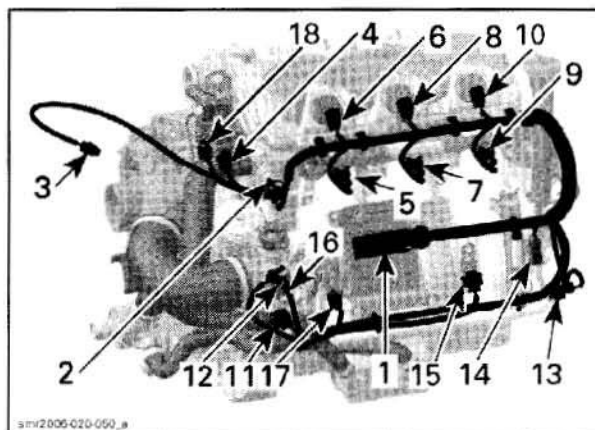

#### ALL 4-TEC SUPERCHARGED ENGINES

1. ECM connector
2. CTS connector
3. EGTS connector
4. CAPS connector
5. Fuel injector connector (cylinder 1)
6. Ignition coil connector (cylinder 1)
7. Fuel injector connector (cylinder 2)
8. Ignition coil connector (cylinder 2)
9. Fuel injector connector (cylinder 3)
10. Ignition coil connector (cylinder 3)
11. TPS connector
12. Idle bypass valve connector
13. MATS connector
14. Engine connector
15. MAPS connector
16. OPS connector
17. KS connector
18. CPS connector

#### Resistance Test

Check continuity of the circuits according to the wiring diagram in the *ELECTRICAL CONNECTORS AND WIRING DIAGRAM* section of this manual.

If wiring harness is good, check the respective sensor/actuator as described in this section.

Otherwise, repair the connectors, replace the wiring harness or the ECM/MPEM as diagnosed.

#### Removal

Remove fuel rail cover.

Disconnect the wiring harness from all sensors/actuators.

Disconnect the ECM connector from the ECM.

Cut all tie raps which are holding the wiring harness in position.

**Section 04 ENGINE MANAGEMENT (1503 4-TEC)**  
**Subsection 03 (ADJUSTMENT AND REPAIR PROCEDURES)**

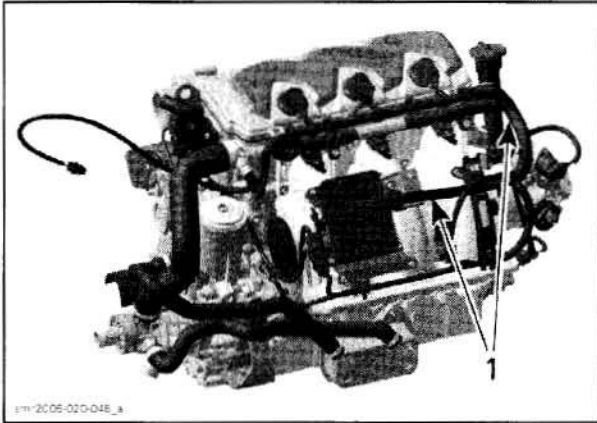

**TYPICAL**  
 1. Wiring harness

Remove complete wiring harness.

**Installation**

First connect the ECM connector A and fix the harness on the wiring support with a locking tie.

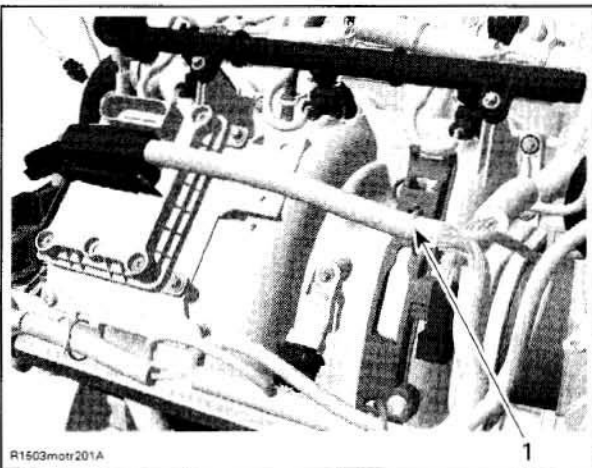

1. Locking tie

Lead the cable bundle with the injector and ignition coil connectors to the fuel rail and fix it also by using 4 locking ties.

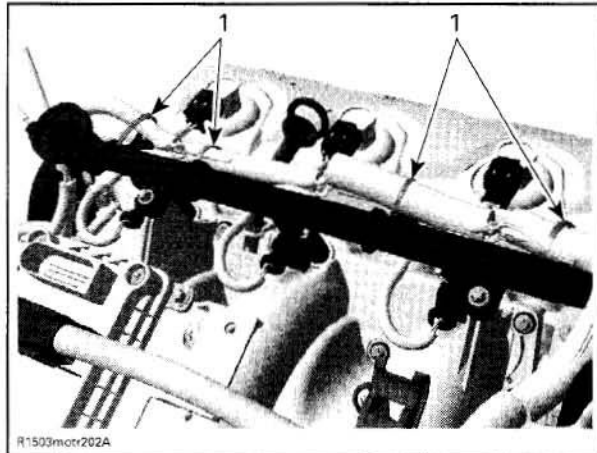

1. Locking ties

Connect the fuel injectors, ignition coils, CAPS, CTS and EGTS to the wiring harness.

**⚠ WARNING**

Pay attention not to mix injectors or ignition coils wires between cylinders. The location of the splice connectors indicate which cylinder wires belong to.

Install the engine connector on the appropriate bracket on the wiring support.

Then fix the other bundle on the appropriate supports on the wiring support and the ECM bracket with locking ties.

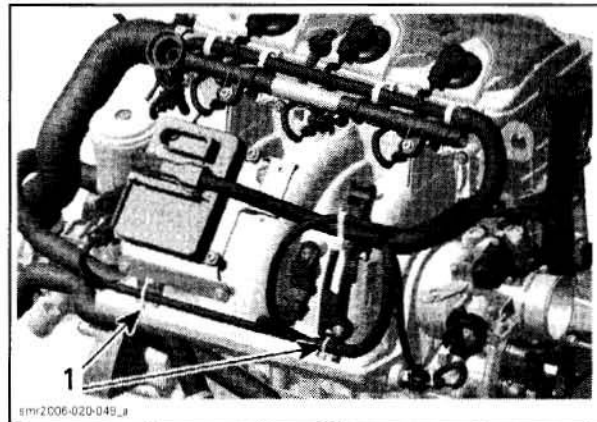

**TYPICAL**  
 1. Locking ties

Connect the CPS, KS, OPS, and the MAPS to the wiring harness.

Also connect now the MATS, TPS, and idle bypass valve to the wiring harness.

Fix the wiring for the MATS with a locking tie to support the cables.



**Section 04 ENGINE MANAGEMENT (1503 4-TEC)**  
Subsection 03 (ADJUSTMENT AND REPAIR PROCEDURES)

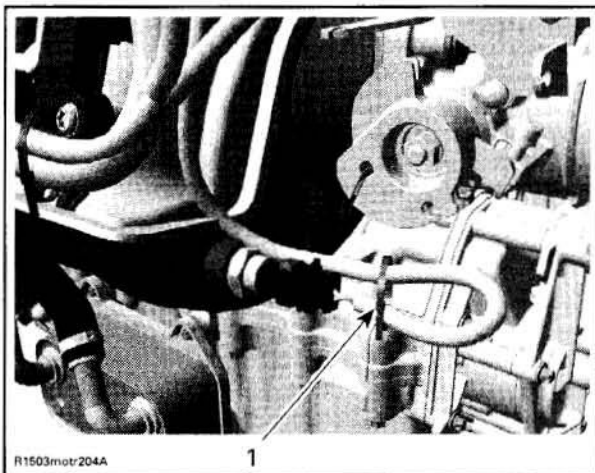

TYPICAL  
1. Locking tie

Install all remaining parts, which has been removed.

## BASIC ADJUSTMENTS

### IDLE SPEED

The idle speed is not adjustable. The ECM controls the idle speed of the engine.

If desired, the engine RPM can be measured following this procedure:

Use tachometer (P/N 529 014 500).

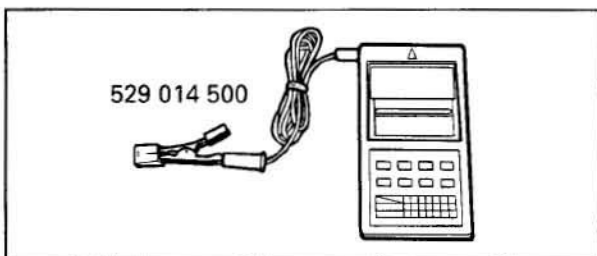

Wrap the tachometer's wire a few times around the protruding part of ignition coil.

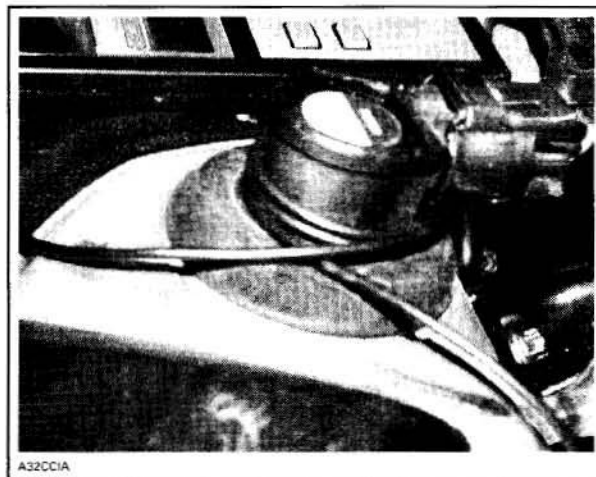

TYPICAL

Start engine to verify engine RPM.

**NOTE:** If idle speed is not within specifications, check if there is any occurred or active fault code(s). If not, check throttle cable adjustment and proceed with the **Closed Throttle and Idle Actuator** reset. If idle speed is still not adequate, there is probably a mechanical problem.

### THROTTLE CABLE

Mechanically adjust the throttle cable.

When throttle is released, cable must have a free play of 0.5 - 4 mm (1/64 - 5/32 in).

Throttle lever must reach handlebar grip without causing strain to cable or brackets. Ensure throttle lever fully closes on it's stopper.

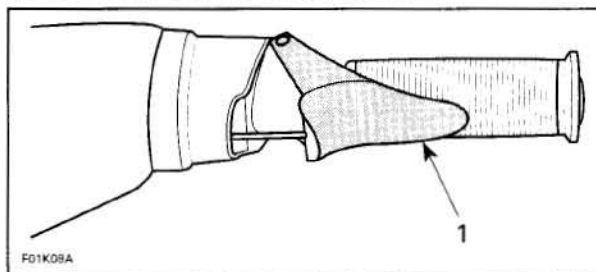

1. Must touch handlebar grip

Ensure throttle body is fully open at full throttle position. At this position, throttle lever stopper is almost in contact with throttle body.

**NOTE:** Apply a light pressure on the throttle plate, a slight play should be obtained.

## Section 04 ENGINE MANAGEMENT (1503 4-TEC)

### Subsection 03 (ADJUSTMENT AND REPAIR PROCEDURES)

**CAUTION:** If there is no free-play at idle position, it may cause poor idling and startability. Improper cable adjustment will cause strain on cable and/or damage cable bracket or throttle lever at handlebar. Do not alter throttle cable routing.

To adjust, loosen jam nut then turn adjustment nut as necessary.

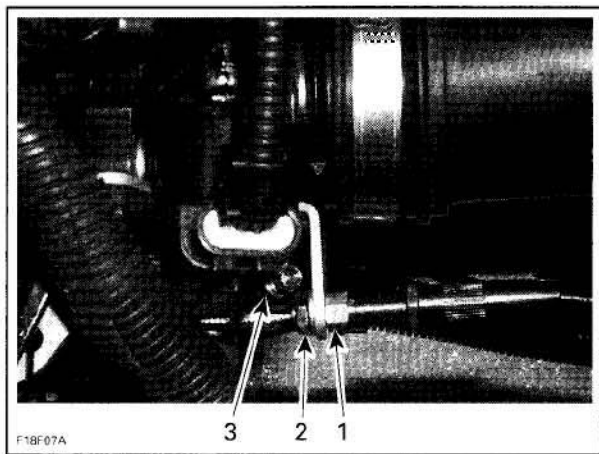

1. Adjustment nut
2. Jam nut
3. Throttle lever stopper

Tighten jam nut and recheck adjustment.

#### **⚠ WARNING**

Make sure idle speed stopper contacts throttle cam when throttle lever is fully released at handlebar.

After cable adjustment, always perform the Closed Throttle and Idle Actuator reset.

### CLOSED THROTTLE AND IDLE ACTUATOR RESET

**NOTE:** This operation performs a reset of the values in the ECM.

This reset is very important. The setting of the TPS will determine the basic parameters for all fuel mapping and several ECM calculations and the setting of the idle bypass valve will determine the basic parameters for the idle speed control of the engine.

**NOTE:** Reset must be done each time the throttle position sensor (TPS) or the idle bypass valve is loosened or removed or throttle body is replaced or ECM is replaced.

**CAUTION:** An improperly set TPS or idle bypass valve may lead to poor engine performance and emission compliance could possibly be affected. In addition, improper idle bypass valve reset may lead to poor engine starting, improper idle (too low or too high) and engine stop on deceleration.

Use the B.U.D.S. software to perform this adjustment.

Ensure the throttle body plate stop lever rest against its stopper. Open throttle approximately one quarter then quickly release. Repeat 2 - 3 times to settle throttle plate. If stopper does not rest against its stop lever, perform throttle cable adjustment.

To properly reset valve, first install safety lanyard then remove it and then wait 5 seconds. Repeat this cycle 2 - 3 times.

Push the **Reset** button in the **Setting** tab of B.U.D.S.

**NOTE:** If TPS is not within the allowed range while resetting the **Closed Throttle and Idle Actuator**, the ECM will generate a fault code and will not accept the setting.

Start engine and make sure it operates normally through its full engine RPM range. If fault codes appear, refer to *EMS DIAGNOSTIC AND COMMUNICATION TOOLS* section for more information.

### IGNITION TIMING

The ECM is able to determine the exact position of camshaft and crankshaft. That means that no ignition timing setting has to be performed.

## REPAIR PROCEDURES

### ENGINE CONTROL MODULE (ECM)

#### ECM Replacement

Prior to replacing a suspected ECM, ensure that all the recommendations in the general introduction of this section have been followed.

If the defective ECM can be read with B.U.D.S., it is possible to transfer the recorded information of this module to the new ECM. Use **Replace ECM** in the **Module** menu of B.U.D.S. Follows instructions in its help system.

If the defective ECM can not be read, continue procedure.

Disconnect battery cables.



---

## Section 04 ENGINE MANAGEMENT (1503 4-TEC)

### Subsection 03 (ADJUSTMENT AND REPAIR PROCEDURES)

---

#### **⚠ WARNING**

Battery BLACK negative cable must always be disconnected first and connected last.

Disconnect both ECM connectors from ECM.

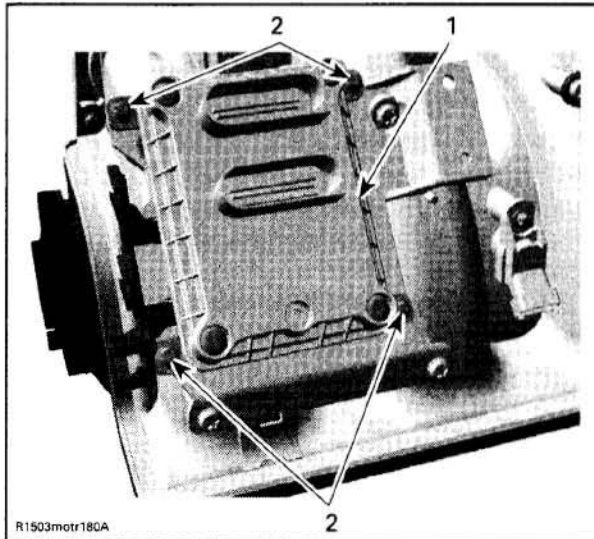

TYPICAL  
1. ECM  
2. Retaining screws

Unscrew all retaining screws and remove the engine ECM from intake manifold.

Install the new ECM to the engine.

**CAUTION:** Always replace ECM by the same part or by an approved equivalent.

Reconnect ECM connectors to ECM then battery cables.

#### **If the Previous ECM was Read with B.U.D.S.**

Transfer the data from the previous ECM to the new one using B.U.D.S. then proceed with the required resets.

Continue procedure as per *FINALIZING ECM REPLACEMENT* below.

#### **If the Previous ECM was NOT Read with B.U.D.S.**

- Enter the old ECM serial number in the Part Replacement under **History** tab. Click on **Add part in History**.
- Reprogram safety lanyard(s).

**NOTE:** The ECM serial number can be found on the ECM sticker that also shows the P/N.

Continue procedure as per *FINALIZING ECM REPLACEMENT* below.

#### **Finalizing ECM Replacement**

**IMPORTANT:** When the ECM is replaced, the Closed Throttle and Idle Actuator must be reset. Refer to *BASIC ADJUSTMENTS* for the procedure.

After performing the required reset, ensure to clear all faults from the newly replaced ECM.

Start the engine and increase engine speed above 5000 RPM to be sure no fault appears.

## MULTI-PURPOSE ELECTRONIC MODULE (MPEM)

### MPEM Replacement

Prior to replacing a suspected MPEM, ensure that all the recommendations in the general introduction of this section have been followed.

If the defective MPEM can be read with B.U.D.S., it is possible to transfer the recorded information to the new MPEM. Use **Replace MPEM** in the **Module** menu of B.U.D.S. Follows instructions in its help system.

If the defective MPEM can not be read, continue procedure.

Disconnect battery cables.

#### **⚠ WARNING**

Battery BLACK negative cable must always be disconnected first and connected last.

Disconnect AMP connectors from MPEM. Remove retaining nuts on top.

Pull MPEM out.

Install the new MPEM in vehicle. Reconnect AMP connectors to MPEM.

#### **If the Previous MPEM was Read with B.U.D.S.**

Transfer the data from the previous MPEM to the new one using B.U.D.S.

Continue procedure as per *FINALIZING MPEM REPLACEMENT* below.

#### **If the Previous MPEM was NOT Read with B.U.D.S.**

- Enter the vehicle and engine serial numbers in the **Vehicle** tab.
- Enter the old MPEM serial number in the **Part Replacement** under **History** tab. Click on **Add part in History**.

**NOTE:** The MPEM serial number can be found on the MPEM sticker that also shows the P/N.

## Section 04 ENGINE MANAGEMENT (1503 4-TEC)

### Subsection 03 (ADJUSTMENT AND REPAIR PROCEDURES)

- Manually activate the options installed on vehicle under the **Setting** tab.

**NOTE:** If an option is installed but not checked in B.U.D.S., the information center will not display that option. If an option is checked in B.U.D.S. but not installed in vehicle, a fault code will be generated.

Continue procedure as per *FINALIZING MPEM REPLACEMENT* below.

#### Finalizing MPEM Replacement

Ensure to clear all faults from the newly replaced MPEM.

Start engine and ensure no fault is active.

## FUEL INJECTOR

**IMPORTANT:** Never mix up fuel injectors of naturally-aspirated and supercharged 4-TEC engines. Doing so will automatically lead to a malfunction of the EMS and will cause a bad engine calibration.

#### Leakage Test

To perform a leakage test, the injectors and fuel rail have to be removed from the engine. See *FUEL INJECTOR REPLACEMENT* below for the procedure.

**NOTE:** Do not detach injectors from the fuel rail. Reconnect the fuel line and the wiring harness.

Place each injector in a clean bowl.

Install the safety lanyard cap on the DESS post to activate the fuel pump.

Check for fuel leakage from the injector nozzle. There should be less than 1 drop per minute. Perform the test for 2 minutes.

If not within specification, replace the fuel injector(s).

Properly reinstall removed parts.

The leakage test is validated when performing the fuel pump pressure test. Refer to *FUEL SYSTEM*.

#### Electrical Test

##### Voltage Test

Safety lanyard must be on DESS post.

Using the B.U.D.S. software, energize the fuel injector from the **Activation** tab.

If the injector does not work, disconnect the connector from the injector.

Install a temporary connector on the injector with wires long enough to make the connection outside the bilge and apply voltage (12 V) to this test harness.

**CAUTION:** While doing fuel injector electrical test, do not apply continuous voltage to the connector. This can damage the injector.

This will validate the injector mechanical and electrical operation.

If it does not work, replace it. If it works, continue procedure.

Using B.U.D.S., activate injector while probing terminal 2 (of injector on harness side) and battery ground.

- If 12 V is read, check continuity of circuit as per following table. If it is good, try a new ECM.

CIRCUIT NUMBER (ECM CONNECTOR "A")	INJECTOR NUMBER
A-15	1
A-33	2
A-14	3

- If it does not read 12 V, check continuity of circuit as per following table. If it is good, try a new MPEM.

CIRCUIT NUMBER (AMP CONNECTOR NO. 2)	INJECTOR NUMBER
2-16	1
2-17	2
2-18	3

#### Resistance Test

Reconnect the injector and disconnect the ECM connector A.

Remove safety lanyard and wait 15 seconds. Disconnect engine connector.

**CAUTION:** Before unplugging engine connector, always remove safety lanyard and wait 15 seconds. Otherwise, damage to CAPS may occur.

Using a multimeter, check resistance value between terminals as follows.



**Section 04 ENGINE MANAGEMENT (1503 4-TEC)**  
**Subsection 03 (ADJUSTMENT AND REPAIR PROCEDURES)**

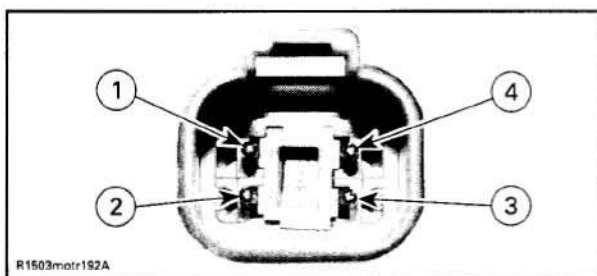

R1503motr152A  
**ENGINE CONNECTOR**

COMPONENT	TERMINAL LOCATION
Fuel injector cylinder 1	1 (engine connector) and A-15 (ECM connector)
Fuel injector cylinder 2	2 (engine connector) and A-33 (ECM connector)
Fuel injector cylinder 3	3 (engine connector) and A-14 (ECM connector)

**4-TEC Naturally Aspirated Models**

The resistance should be between 11.4 and 12.6  $\Omega$ .

If resistance value is correct, try a new ECM. Refer to *ENGINE CONTROL MODULE (ECM)* in this section.

If resistance value is incorrect, repair the wiring harness/connectors or replace the wiring harness between ECM connector and fuel injector.

**All 4-TEC Supercharged Models**

The resistance should be between 14 and 15  $\Omega$ .

If resistance value is correct, try a new ECM. Refer to *ENGINE CONTROL MODULE (ECM)* in this section.

If resistance value is incorrect, repair the wiring harness/connectors or replace the wiring harness between ECM connector and fuel injector.

**Fuel Injector Replacement**

**Removal**

Remove fuel rail cover from the engine.

Release the fuel pressure in the system using B.U.D.S. Look in the **Activation** tab.

Disconnect wiring harness from the three fuel injectors.

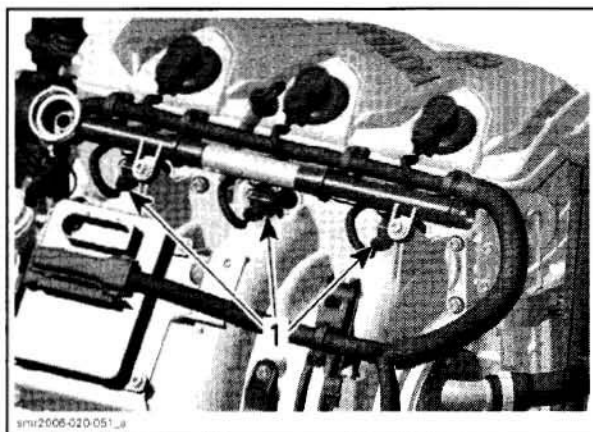

1. Fuel injector connectors

Disconnect fuel hose using the fuel hose disconnect tool (P/N 529 036 037).

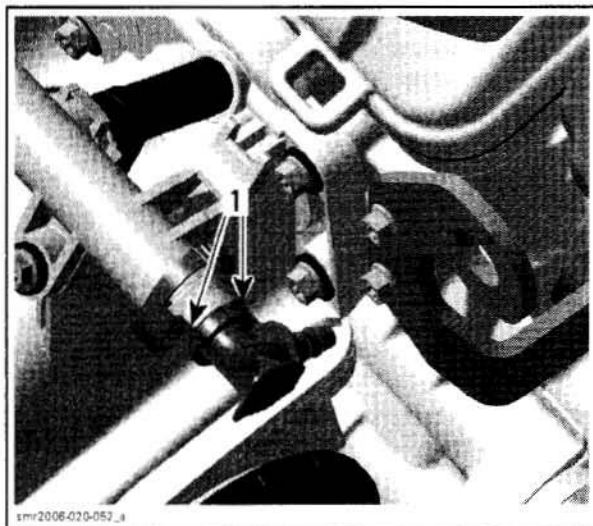

1. Insert pointed tool each side

Wrap a rag around the hose end to prevent rail draining.

Cut tie raps and remove the wiring harness from the fuel rail.

Unscrew rail retaining screws.

Gently pull rail up by hand, working each side slightly at a time.

Pull rail out with fuel injectors.

Then remove the injector clip. Now the fuel injector can be easily pulled out of the fuel rail.

## Section 04 ENGINE MANAGEMENT (1503 4-TEC)

### Subsection 03 (ADJUSTMENT AND REPAIR PROCEDURES)

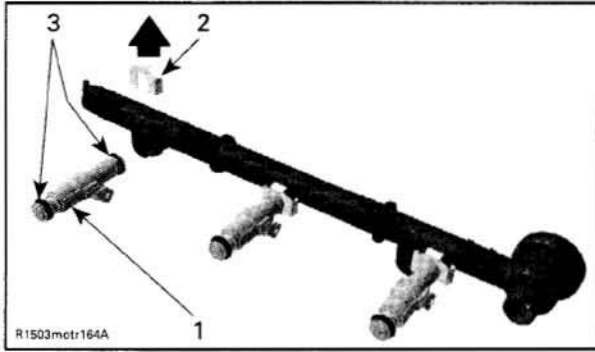

#### FUEL RAIL ASS'Y

1. Fuel injector
2. Injector clip
3. O-ring

#### Installation

For the installation, reverse the removal procedure. Paying attention to the following details.

If you reinstall a used injector, carefully inspect O-ring condition before reinstalling fuel injector. Replace O-ring with a new one if damaged. Insert the fuel injector in place with your hand.

**NOTE:** A thin film of engine oil should be applied to O-rings to ease insertion in fuel rail and intake manifold.

Apply Loctite 243 on rail retaining screws then torque to 10 N•m (89 lbf•in).

When installing fuel line connector to the fuel rail, put some oil on the O-ring to ease installation.

#### **WARNING**

Perform a fuel pressure test and ensure that there is no leak. Refer to *FUEL SYSTEM* section.

## THROTTLE BODY

**IMPORTANT:** Never mix up throttle bodies of naturally-aspirated and supercharged 4-TEC engines. Doing so will automatically lead to a malfunction of the EMS and will cause a bad engine calibration.

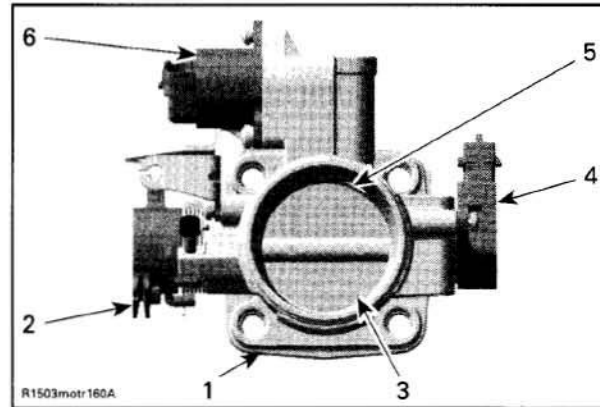

#### TYPICAL

1. Throttle body
2. Throttle cable attachment
3. Throttle plate
4. TPS
5. Idle bypass channel
6. Idle bypass valve

The adjustment of the idle stop screw is optimized by the throttle body manufacturer and locked to prevent any modification.

**CAUTION:** Never attempt to adjust the idle speed through this screw. See *IDLE SPEED* in *BASIC ADJUSTMENTS*.

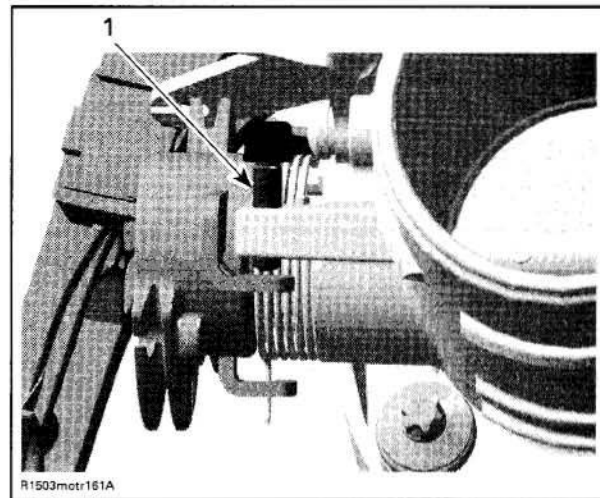

#### THROTTLE BODY

1. Idle stop screw (do not tamper adjustment)

## Mechanical Inspection

Check that the throttle plate moves freely and smoothly when depressing throttle lever. Throttle plate must return freely, quickly and completely. If not, check for salt accumulation on throttle plate shaft. Try lubricating throttle plate shaft, moving plate several times and recheck. Replace throttle body if necessary.



## Section 04 ENGINE MANAGEMENT (1503 4-TEC)

### Subsection 03 (ADJUSTMENT AND REPAIR PROCEDURES)

#### **⚠ WARNING**

Replace throttle body when throttle plate does not return properly.

Before replacing any part, check the following as these could be causing the fault. Perform the test while the engine is not running.

- Throttle cable adjustment too tight. Not returning fully to idle stop.
- Throttle body idle set screw is loose or worn (in this case, throttle body must be replaced).
- TPS is loose.
- Idle bypass valve is loose.
- Corroded or damaged wiring or connectors.
- Throttle body has been replaced and the **Closed Throttle and Idle Actuator** reset has not been performed.
- ECM has been replaced and the **Closed Throttle and Idle Actuator** reset has not been performed.

#### Electrical Inspection

Refer to *THROTTLE POSITION SENSOR (TPS)* and *IDLE BYPASS VALVE* further in this section.

#### Replacement

##### Removal

To remove the throttle body from engine, proceed as follows:

- Disconnect air intake silencer from throttle body. Move boot away.
- Remove retaining screws of throttle body.

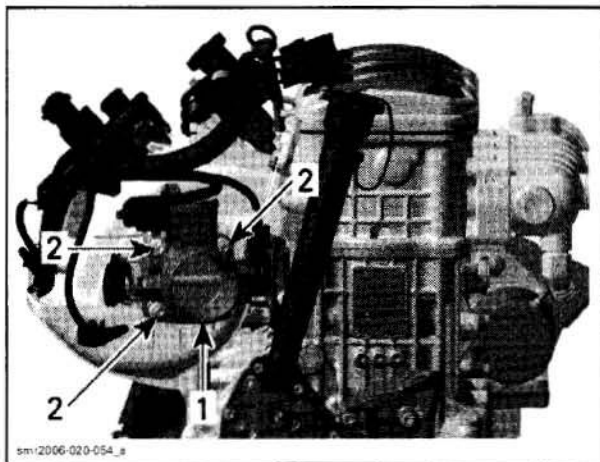

**4-TEC NATURALLY ASPIRATED MODELS**  
1. Throttle body  
2. Screws

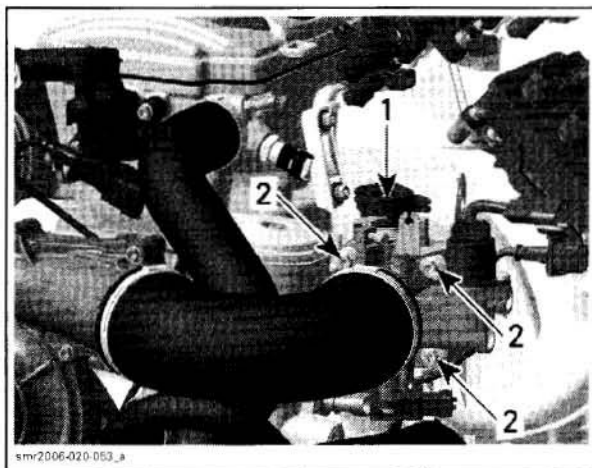

**ALL 4-TEC SUPERCHARGED MODELS**

1. Throttle body  
2. Screws

- Slightly pull throttle body out.
- Disconnect connectors from idle bypass valve, and TPS.
- Disconnect throttle cable.

##### Installation

Installation of the new throttle body is the reverse of the removal procedure.

Make sure throttle cable is correctly adjusted.

Perform the **Closed Throttle and Idle Actuator** reset. See procedure in *BASIC ADJUSTMENTS*.

#### THROTTLE POSITION SENSOR (TPS)

##### General

The throttle position sensor (TPS) is a potentiometer that sends a signal to the ECM which is proportional to the throttle plate angle.

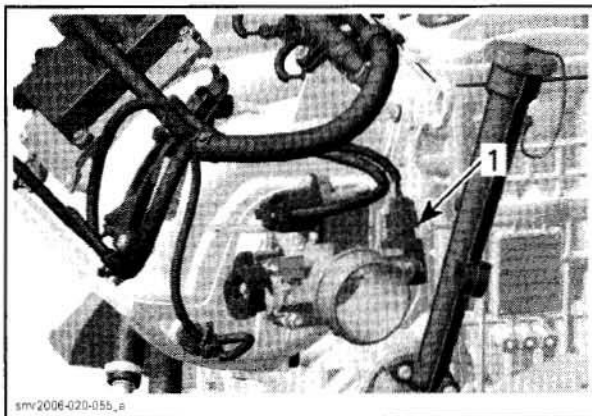

**4-TEC NATURALLY ASPIRATED ENGINES**  
1. Throttle position sensor (TPS)

**Section 04 ENGINE MANAGEMENT (1503 4-TEC)**  
**Subsection 03 (ADJUSTMENT AND REPAIR PROCEDURES)**



ALL 4-TEC SUPERCHARGED ENGINES  
 1. Throttle position sensor (TPS)

**IMPORTANT:** Prior to testing the TPS, ensure that mechanical components are adequate according to *THROTTLE BODY* above.

The EMS may generate several fault codes pertaining to the TPS. Refer to *EMS DIAGNOSTIC AND COMMUNICATION TOOLS* section for more information.

**Wear Test**

While engine is not running, activate throttle and pay attention for smooth operation without physical stops of the cable.

Using the B.U.D.S. software, use the **Throttle Opening** display under **Monitoring** tab.

Slowly and regularly depress the throttle. Observe the needle movement. It must change gradually and regularly as you move the throttle. If the needle "sticks", bounces, suddenly drops or if any discrepancy between the throttle movement and the needle movement is noticed, it indicates a worn TPS that needs to be replaced.

**Voltage Test**

Check the ECM voltage output from to the throttle position sensor.

Disconnect connector from throttle position sensor. To unlock connector, insert a small screwdriver between the folded tab.

**NOTE:** On the **Supercharged models**, a mirror is useful to see under throttle body.

To see the connector pin-out, temporarily remove the connector shield joining the harness, to expose the terminal numbers. Connect a voltmeter to the terminals of the wiring harness as per the following table.

Remove and reinstall the safety lanyard to activate the ECM.

Check the voltage readings as follows.

CONNECTION	VOLTAGE
Terminal 1 with engine ground	0 V
Terminal 2 with engine ground	5 V
Terminal 3 with engine ground	4.5 - 5 V

If voltage test is good, replace the TPS.

If voltage test is not good, check the resistance of the TPS circuit.

**Resistance Test**

Reconnect the TPS.

Disconnect the ECM connector "A" on the ECM. Using a multimeter, check resistance values as per the following table.

ECM CONNECTOR		THROTTLE IDLE POSITION	WIDE OPEN THROTTLE POSITION
PIN	PIN	RESISTANCE Ω	
A-24	A-25	1000 - 1100	2600 - 2700
A-25	A-39	1600 - 2400	1600 - 2400
A-24	A-39	2500	1000 - 1100

**NOTE:** The resistance value should change smoothly and proportionally to throttle movement. Otherwise, replace TPS.

If resistance values are correct, try a new ECM. Refer to *ENGINE CONTROL MODULE (ECM)* in this section.

If resistance values are incorrect, replace TPS.

**Replacement**

Remove the throttle body as described above.

Loosen two screws retaining the TPS.

Remove TPS.



## Section 04 ENGINE MANAGEMENT (1503 4-TEC)

### Subsection 03 (ADJUSTMENT AND REPAIR PROCEDURES)

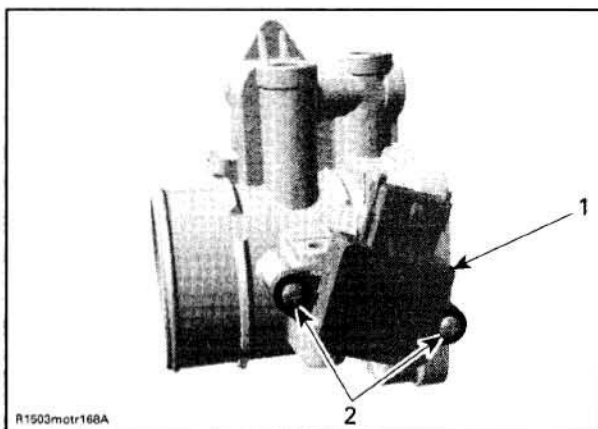

#### THROTTLE BODY

1. Throttle position sensor (TPS)
2. Screws

Apply Loctite 243 on screw threads, install the new TPS.

Reinstall remaining removed parts.

Proceed with the **Closed Throttle and Idle Actuator** reset as described in *BASIC ADJUSTMENTS*.

## IDLE BYPASS VALVE

An idle bypass valve with good resistance measurement can still be faulty. It is also possible that a mechanical failure occurs which is not detectable without measuring the air flow. Replacing the idle bypass valve may be necessary as a test.

### Resistance Test

Disconnect idle bypass valve from the wiring harness.

Using a multimeter, check the resistance in both windings.

Check the resistance between terminals A and D and also between terminals C and B of the idle bypass valve.

The resistance in each winding should be approximately 50  $\Omega$  at 23°C (73°F).

If the resistance of one or both windings is not good, replace the idle bypass valve.

If resistance test of valve windings is good, check continuity of circuits A-35, A-36, A-37, A-38.

### Visual Inspection

Remove idle bypass valve from throttle body.

Check the piston and bypass channel for dirt/deposits which can cause a sticking piston.

**CAUTION:** Do not try to operate the piston of the idle bypass valve when it is dismantled. Also do not move the piston by hand. The screw drive is very sensitive and will be destroyed.

Clean the parts and install the idle bypass valve on the throttle body.

Proceed with the **Closed Throttle and Idle Actuator** reset as described in *BASIC ADJUSTMENTS*.

## CRANKSHAFT POSITION SENSOR (CPS)

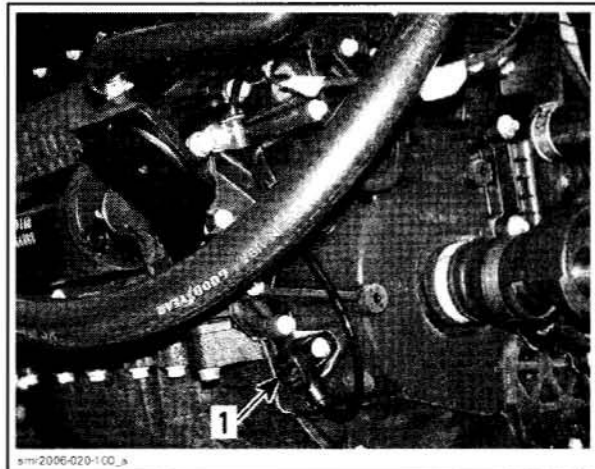

1. Crankshaft Position Sensor (CPS)

Ensure that information center works. Needles will sweep, LED and LCD segments will turn on when the safety lanyard is installed. Check for RPM display at the information center while cranking in engine drowned mode. Press and HOLD throttle lever then press start/stop button. 800 - 1000 RPM should display. Otherwise perform the following tests.

**NOTE:** Take into account that a CPS fault can be triggered by a bent or missing trigger wheel tooth. First check fault codes then CPS as per following procedure; if it tests good, verify trigger wheel teeth condition. Refer to *PTO HOUSING AND MAGNETO* in the *ENGINE* section.

Disconnect CPS wiring harness connector. Probe terminals coming from CPS while cranking engine. Voltage should be within 1 - 2 Vac. Otherwise, inspect wiring and replace CPS if wiring is good.

### Resistance Test

Disconnect the CPS connector from the wiring harness and check the resistance of the sensor itself.

## Section 04 ENGINE MANAGEMENT (1503 4-TEC)

### Subsection 03 (ADJUSTMENT AND REPAIR PROCEDURES)

The resistance should be between 190  $\Omega$  and 290  $\Omega$ .

Otherwise, replace the CPS.

If resistance tests good, reconnect the CPS and disconnect the ECM connector A on the ECM.

Using a multimeter, recheck resistance value between terminals 5 and 19.

If resistance value is correct, try a new ECM. Refer to *ENGINE CONTROL MODULE (ECM)* in this section.

If resistance value is incorrect, repair the connectors or replace the wiring harness between ECM connector and the CPS.

#### Replacement

Drain oil from PTO housing. Refer to *PTO HOUSING AND MAGNETO*.

**NOTE:** It is not necessary to drain oil from engine. Disconnect CPS connector.



1. CPS connector

Remove wire retaining clip.  
Remove CPS retaining screw.

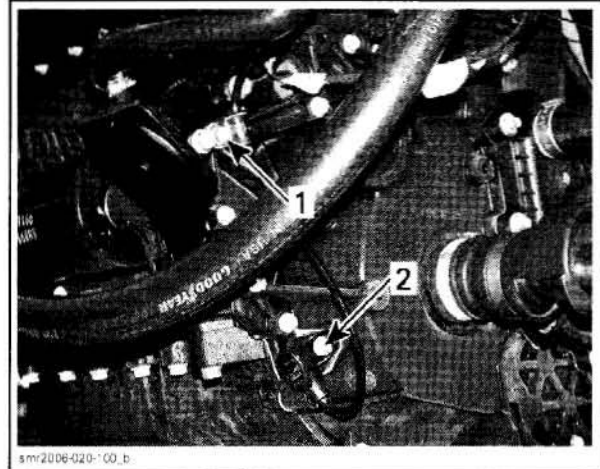

1. Wire retaining clip  
2. CPS retaining screw

Pull out CPS.

Reverse procedure for installation. However, pay attention to the following.

Apply Loctite 243 (P/N 293 800 060) on screw threads then torque to 9 N•m (80 lbf•in).

Readjust the engine oil level.

#### Trigger Wheel Inspection

Refer to *PTO HOUSING AND MAGNETO* in the *ENGINE* section.

#### CAMSHAFT POSITION SENSOR (CAPS)

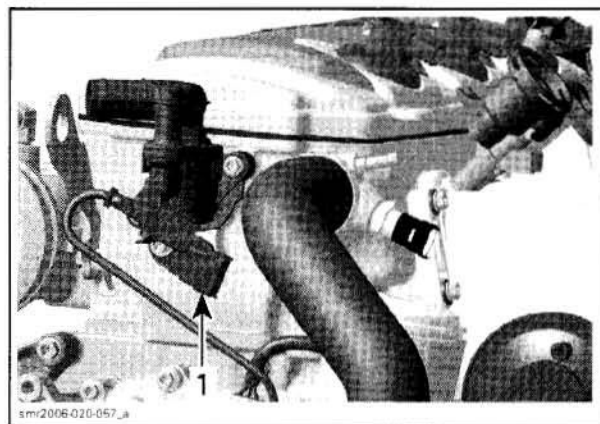

1. CAPS

#### Voltage Test (harness)

Disconnect the connector from the wiring harness.

To see the connector pin-out, temporarily remove the connector shield joining the harness, to expose the terminal numbers.



## Section 04 ENGINE MANAGEMENT (1503 4-TEC)

### Subsection 03 (ADJUSTMENT AND REPAIR PROCEDURES)

Remove and reinstall safety lanyard to activate the system.

Probe terminal 3 of CAPS connector (wiring harness side) and battery ground.

- If 12 V is read, check continuity of circuits A-20 and A-34. If they test good, perform the CAPS voltage test as explained below. If CAPS tests good, try a new ECM.
- If 12 V is not read, check continuity of circuit 2-19 from MPEM to the CAPS. If it tests good, try a new MPEM. Otherwise, repair wiring harness.

Remove the CAPS from the cylinder head.

Set up the following electric circuit to perform the voltage test.

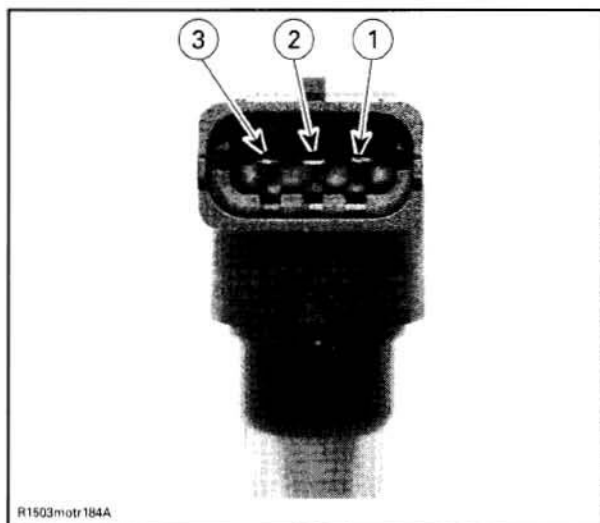

CAPS PIN-OUT

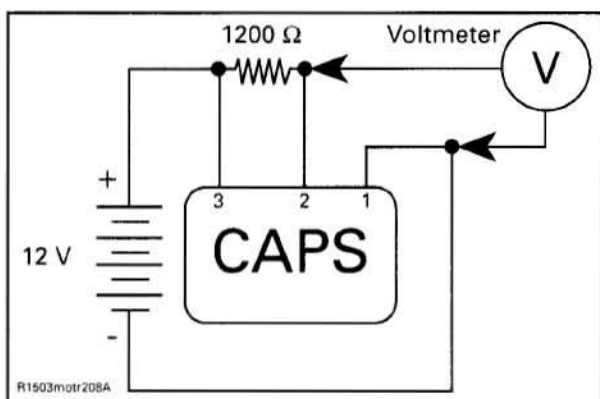

Touch the CAPS with a conductor (ex.: screwdriver) and look if the voltage at the multimeter switches from 12 V to less than 1 V.

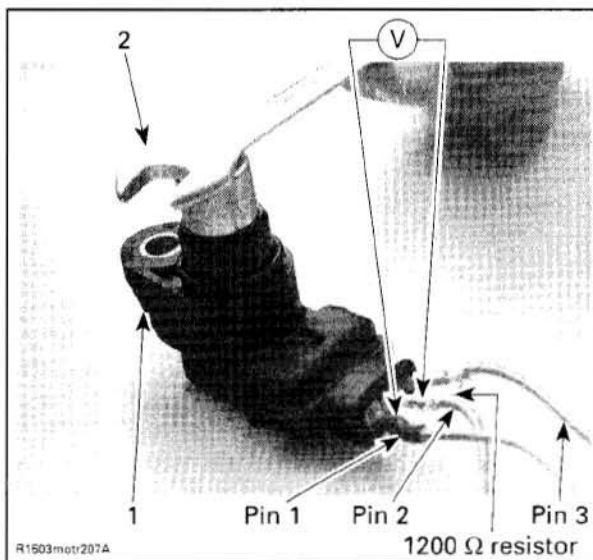

1. CAPS
2. Conductor

If the voltage is not good, replace the CAPS.

#### Replacement

Unscrew the retaining screw and replace the CAPS. Ensure to reinstall O-ring.

Apply Loctite 243 (blue) on thread and torque to 6 N•m (53 lbf•in).

#### MANIFOLD AIR TEMPERATURE SENSOR (MATS)

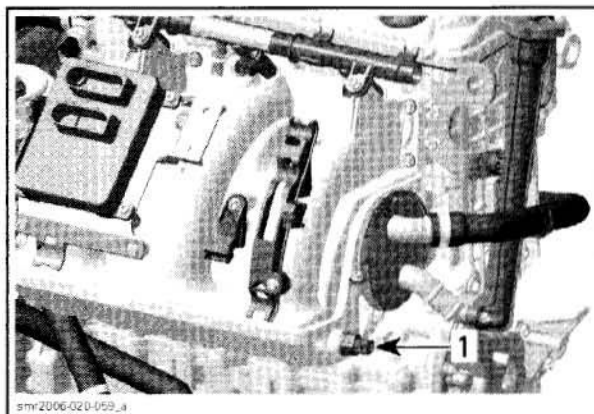

TYPICAL — INTAKE MANIFOLD  
1. Manifold air temperature sensor (MATS)

#### Resistance Test

Disconnect the connector from the MATS and check the resistance of the sensor itself.

The resistance should be between 2280  $\Omega$  and 2740  $\Omega$  at 20°C (68°F).

**Section 04 ENGINE MANAGEMENT (1503 4-TEC)**  
**Subsection 03 (ADJUSTMENT AND REPAIR PROCEDURES)**

Ensure sensor is correctly installed on intake manifold. Otherwise, the MAPS could generate a fault code for an unexpected sensor range at idle when it reads the atmospheric pressure. Remove sensor and check for oil or dirt on its end and if problem persists, check throttle plate condition/position and the wiring harness. Perform the following tests.

**Voltage Test**

Check the voltage output from ECM to the manifold air pressure sensor (MAPS).

Disconnect connector from MAPS and connect a voltmeter to the terminals of the wiring harness as per the following table.

CONNECTION	VOLTAGE
Terminal 1 with engine ground	5 V
Terminal 2 with engine ground	0 V
Terminal 3 with engine ground	0 V

Remove and reinstall the safety lanyard to activate the ECM.

If voltage test is good, replace the MAPS.

If voltage test is not good, check the continuity of the MAPS circuit.

**Resistance Test**

Disconnect the ECM connector A on the ECM.

Using a multimeter, check continuity of circuits 12, 28 and 40.

If wiring harness is good, try a new ECM. Refer to *ENGINE CONTROL MODULE (ECM)* in this section.

Otherwise, repair the connectors or replace the wiring harness between ECM connector and the MAPS.

**Replacement**

Disconnect MAPS connector and remove the MAPS.

Install the new MAPS paying attention to index its tab into the adaptor notch. Apply Loctite 243 (blue) on screw then torque to 10 N•m (89 lbf•in).

**EXHAUST GAS TEMPERATURE SENSOR (EGTS)**

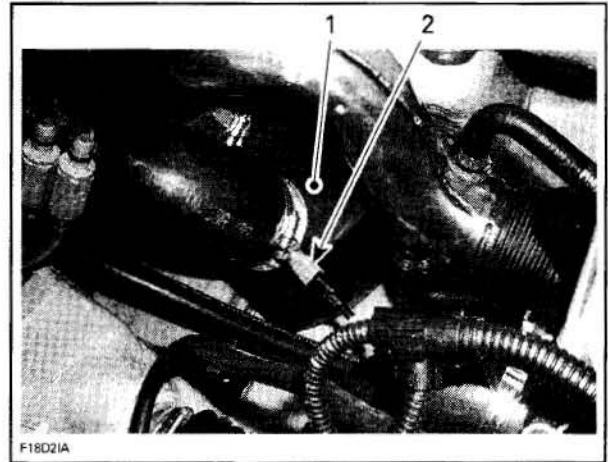

**TYPICAL**  
 1. Muffler  
 2. Exhaust gas temperature sensor (EGTS)

**NOTE:** Overheat signals will appear when exhaust temperature reaches:

ENGINE	TEMPERATURE
All 1503	100°C (212°F)

**Resistance Test**

Disconnect the connector from the EGTS and check the resistance of the sensor itself.

The resistance should be between 2280 Ω and 2740 Ω at 20°C (68°F).

Otherwise, replace the EGTS.

If resistance tests good, reconnect the EGTS and disconnect the ECM connector A on the ECM.

Using a multimeter, recheck resistance value between terminals 10 and 26.

If resistance value is correct, try a new ECM. Refer to *ENGINE CONTROL MODULE (ECM)* in this section.

If resistance value is incorrect, repair the connector or replace the wiring harness between ECM connector and the EGTS.

**Replacement**

Disconnect EGTS connector and remove EGTS.

Apply Loctite 518 on threads of the EGTS then install.

Replug connector.



## KNOCK SENSOR (KS)

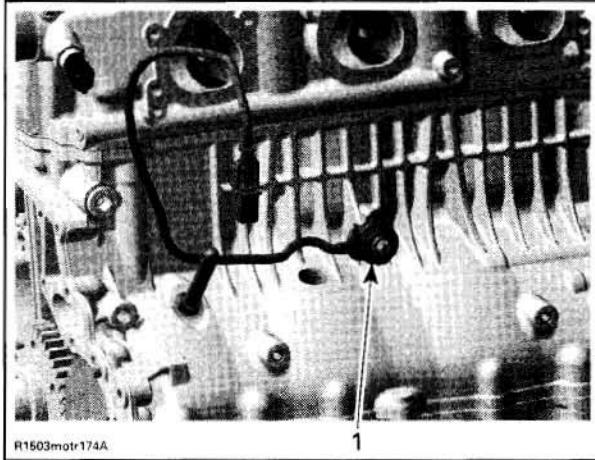

1. Knock sensor (KS)

### Dynamic Test

Using the B.U.D.S. software, monitor the knock sensor using the **Faults** section.

Start the engine and bring engine RPM above 5000 RPM. If no fault code occurs, the knock sensor is good.

Otherwise, do the following.

Ensure sensor and cylinder head contact surfaces are clean and mounting bolt and washer are correct and properly torqued down.

**NOTE:** It is necessary to remove intake manifold to inspect contact surfaces. Refer to *INTAKE MANIFOLD AND INTERCOOLER* section.

Check the knock sensor resistance.

### Static Resistance Test

Disconnect the connector from knock sensor harness.

Using a multimeter, check the resistance between both terminals on the knock sensor.

The resistance should be approximately 5 M $\Omega$ .

If resistance is not good, replace knock sensor.

If resistance is good, reconnect the knock sensor connector and disconnect A connector from ECM.

Using a multimeter, recheck resistance value between terminals 9 and 23.

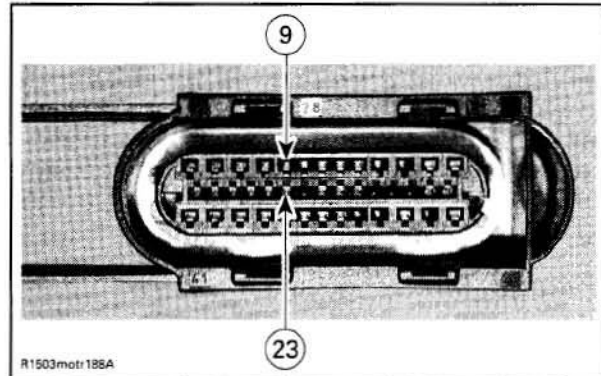

If wiring harness is good, try a new ECM. Refer to *ENGINE CONTROL MODULE (ECM)* in this section.

Otherwise, repair the connector or replace the wiring harness between ECM connector and knock sensor.

### Replacement

Remove the intake manifold. Refer to *INTAKE MANIFOLD AND INTERCOOLER* in the *ENGINE* section.

Unscrew and remove knock sensor.

Clean contact surface, apply Loctite 243 in threaded hole then install the new knock sensor.

Torque screw to 24 N•m (18 lbf•ft).

**CAUTION:** Improper torque might prevent sensor to work properly and lead engine to severe damage of internal components.

Replug connector.

## OIL PRESSURE SENSOR (OPS)

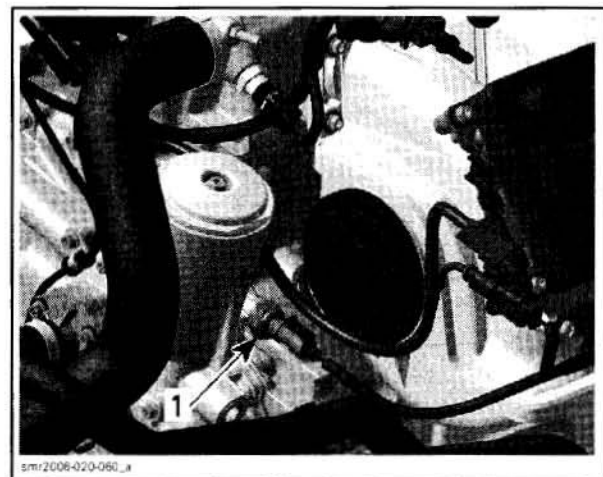

TYPICAL  
1. OPS

## Section 04 ENGINE MANAGEMENT (1503 4-TEC)

### Subsection 03 (ADJUSTMENT AND REPAIR PROCEDURES)

#### Oil Pressure Test

First, carefully check the condition of the connector terminals. Clean to remove dirt and corrosion that could affect proper operation of the sensor.

**IMPORTANT:** Do not apply dielectric grease on terminal.

To check the function of the oil pressure sensor, an oil pressure test has to be performed. Refer to *LUBRICATION SYSTEM* in the *ENGINE* section.

If the engine oil pressure is good, the OIL message in the information center is present and the beeper is ON, check the resistance of the OPS while engine is off and while engine is running. A dynamic test of the circuit can also be conducted.

#### Resistance Test

Disconnect the connector from the OPS and use a multimeter to check the resistance between OPS terminal and engine ground while engine is stopped (without oil pressure) and while engine is running (with oil pressure).

When engine is stopped the resistance is close to  $0\ \Omega$  (normally closed switch).

When engine is running and the oil pressure reaches 180 - 220 kPa (26 - 32 PSI), the resistance of the OPS is infinitely high.

If resistance values are incorrect, replace OPS.

If the values are correct, check the continuity of the wiring harness.

Disconnect the ECM connector A from the ECM and check continuity of circuit 6.

If wiring harness is good, try a new ECM. Refer to *ENGINE CONTROL MODULE (ECM)* in this section.

Otherwise, repair the connector or replace the wiring harness between ECM connector and OPS.

#### Dynamic Test

First, ensure an oil pressure test is performed and the pressure is within specifications.

Disconnect the connector from the oil pressure sensor (OPS).

Start the engine.

Ground the OPS connector AND bring engine speed above 3300 RPM.

A fault code and low oil should appear in the information center. If so, try a new sensor.

Otherwise, check wiring continuity between sensor and MPEM.

#### TOPS SWITCH

When watercraft tips over, that changes TOPS switch state and the ECM shuts down engine.

As a quick test, use B.U.D.S. to monitor switch state. Look in **Monitoring** tab. If it does not work, do the following tests.

Disconnect TOPS switch and remove from MPEM bracket.

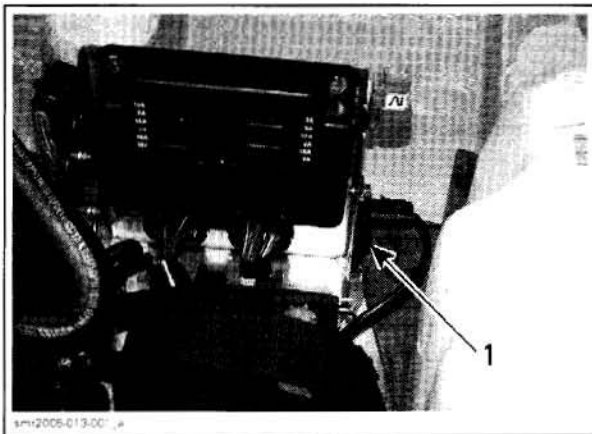

1. Tops switch

Install a temporary connector with 3 wires to TOPS switch.

Connect battery positive terminal to pin A of connector and battery ground to pin B.

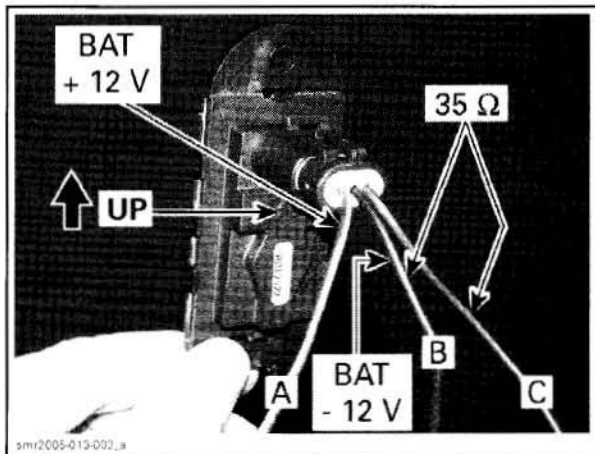

Measure resistance between pin A and C. In the UP position, it should be approximately  $35\ \Omega$ .

Turn switch upside down. It should now read approximately  $10\ k\Omega$ . Otherwise, replace switch.

**NOTE:** While turning switch upside down, ensure that switch resistance does not change before it reaches  $120^\circ \pm 10$  from the vertical axis. From the upside down position, switch resistance should not change before  $60^\circ \pm 10$  from the vertical axis.



**Section 04 ENGINE MANAGEMENT (1503 4-TEC)**  
Subsection 03 (ADJUSTMENT AND REPAIR PROCEDURES)

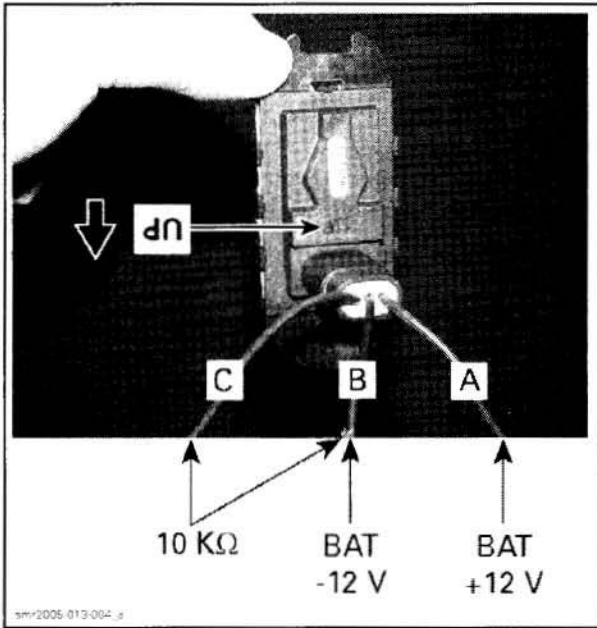

If switch tests good, make sure DESS key is on, and check if there is battery voltage between pins A and B of switch harness connector.

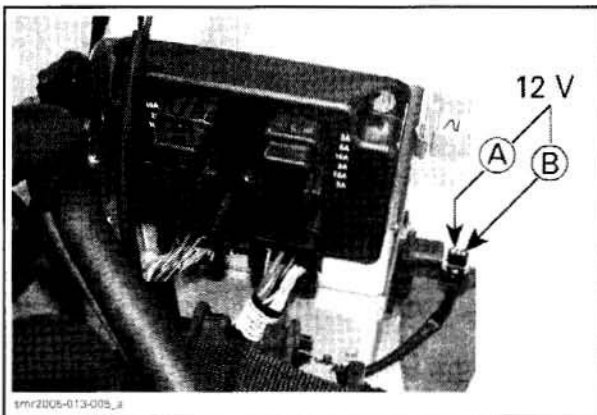

*MEASURE WHEN DESS KEY IS ON*

If battery voltage is not read, check TOPS switch fuse condition. If good, check continuity of circuits 2-2 and 2-25 going to MPEM. If continuity does not test good, repair/replace wiring/connector. If it tests good, try a new MPEM.

If battery voltage is read, check continuity between pin C and B-9 at ECM. If continuity does not test good, repair/replace wiring/connector. If it tests good, try a new ECM.

# FUEL TANK AND FUEL PUMP

## SERVICE TOOLS

<b>Description</b>	<b>Part Number</b>	<b>Page</b>
fuel pressure gauge.....	529 035 591 .....	211
hook tool.....	529 035 989 .....	214
pliers.....	295 000 070 .....	212
small hose pincher.....	295 000 076 .....	209
vacuum/pressure pump.....	529 021 800 .....	209





## GENERAL

### WARNING

The fuel system of a fuel injection system holds much more pressure than on a carbureted watercraft. Prior to disconnecting a hose or to removing a component from the fuel system, follow the recommendation described here.

### WARNING

Fuel lines remain under pressure at all times. Always proceed with care and use appropriate safety equipment when working on pressurized fuel system. Wear safety glasses. Always disconnect battery prior to working on the fuel system. Fuel is flammable and explosive under certain conditions. Always work in a well ventilated area. Do not allow fuel to spill on hot engine parts and/or on electrical connectors. Proceed with care when removing/installing high pressure test equipment or disconnecting fuel line connections. Use B.U.D.S. software to release fuel pressure prior to removing a hose. Cover the fuel line connection with an absorbent shop rag. Slowly disconnect the fuel hose to minimize spilling. Wipe off any fuel spillage in the bilge. Before reconnecting battery, make sure there is no fuel odor present and if so, vent the bilge area thoroughly.

### WARNING

Whenever repairing the fuel system, always verify for water infiltration in reservoir. Replace any damaged, leaking or deteriorated fuel lines. When the repair is completed, ensure that hoses from fuel rail going to fuel pump are properly secured in their supports. Then, pressurize the fuel system. After performing a pressure test, use the valve on the fuel pressure gauge to release the pressure (if so equipped).

### WARNING

Ensure to verify fuel line connections for damage and that NO fuel line is disconnected prior to installing the safety lanyard on the DESS post. Always perform the high pressure test if any component has been removed. A pressure test must be done before connecting the safety lanyard. The fuel pump is started each time the safety lanyard is installed and it builds pressure very quickly.

## INSPECTION

### FUEL SYSTEM LEAK TEST

#### WARNING

Whenever doing any type of repair on watercraft or if any components of the fuel system are disconnected, a pressure test must be done before starting engine. Ensure to verify fuel line ends for damage. Always cut damaged end before reinstallation.

Fill up fuel tank. Reinstall and tighten fuel cap.

Install a small hose pincher (P/N 295 000 076) on vent line (OUTLET side).

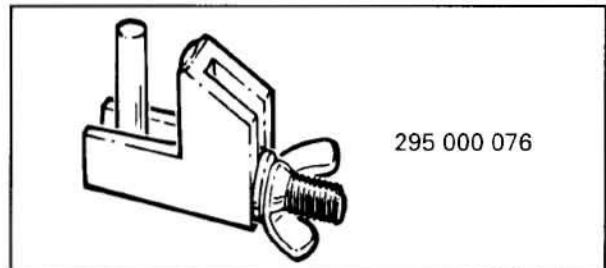

Disconnect inlet valve from body.

Use the vacuum/pressure pump (P/N 529 021 800).

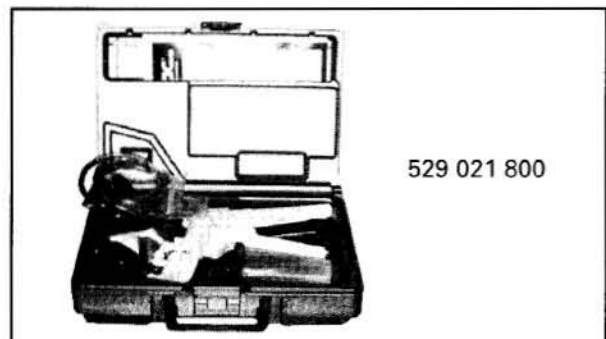

Pressurize fuel tank through vent line (INLET side) as follows.



## Section 05 FUEL SYSTEM

### Subsection 01 (FUEL TANK AND FUEL PUMP)

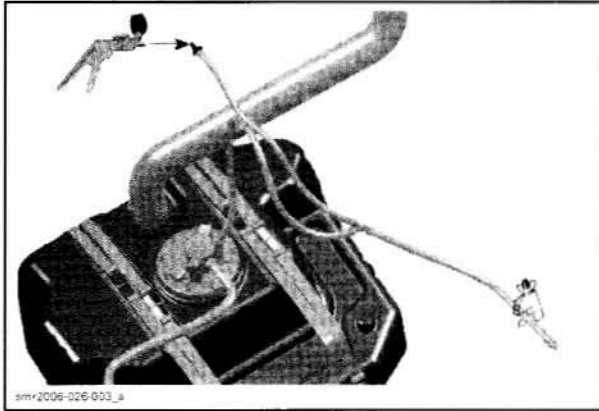

PRESSURE	TIME WITHOUT PRESSURE DROP
34 kPa (5 PSI)	10 minutes

If pressure drops, locate fuel leak(s) and repair/replace leaking component(s).

To ease locating leak(s), spray soapy water on components; bubbles will indicate leak location(s).

#### **WARNING**

If any leak is found, do not start the engine and wipe off any fuel leakage. Do not use electric powered tools on watercraft unless system has passed pressure test.

#### Check Valve and Pressure Relief Valve

Air can enter fuel tank at all times through INLET side.

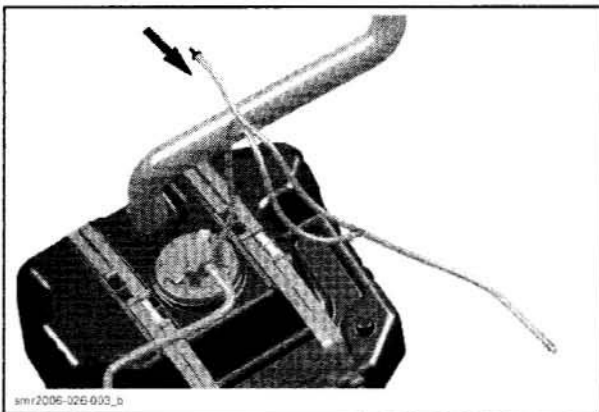

The check valve no. 18 prevents fuel to flow out. Air cannot go out (unless pressure increases).

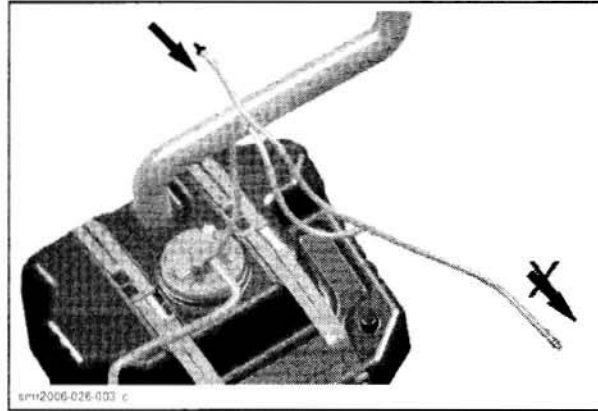

#### **WARNING**

If pressure relief valve is stuck, the pressure in fuel system will build up and it may cause fuel leakage in engine compartment.

Always reinstall valve with the black side as shown.

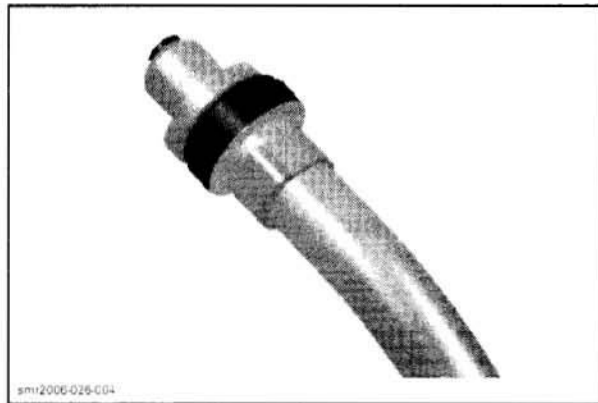

If pressure in fuel tank build up and exceed 3.5 kPa (.5 PSI), pressure relief valve no. 17 open and let excess pressure evacuate through OUTLET side.

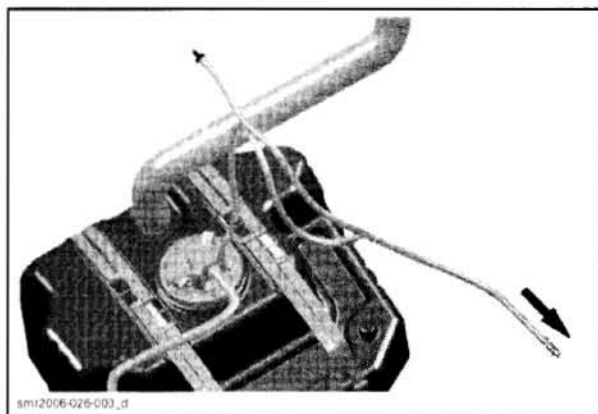

Always reinstall valve according to arrow on valve as shown.

**Section 05 FUEL SYSTEM**  
Subsection 01 (FUEL TANK AND FUEL PUMP)

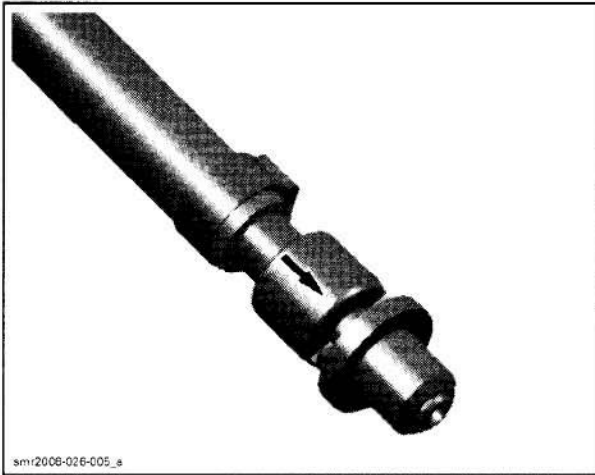

**Test**

Pressurized fuel tank (see above) and proceed as follows:

When removing hose pincher, alternately touch and release end of pressure relief valve no. 17. You should feel pressurized air flowing out indicating relief valve is working.

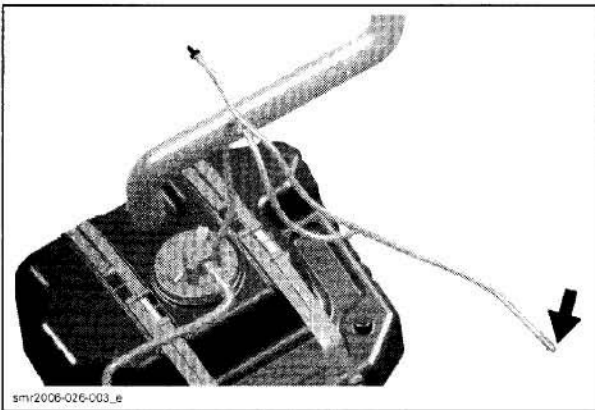

Ensure grommets no. 20 are not plugged.

Remove fuel tank cap.

With your mouth, blow air from outlet nipple. Air must freely flows towards fuel tank neck.

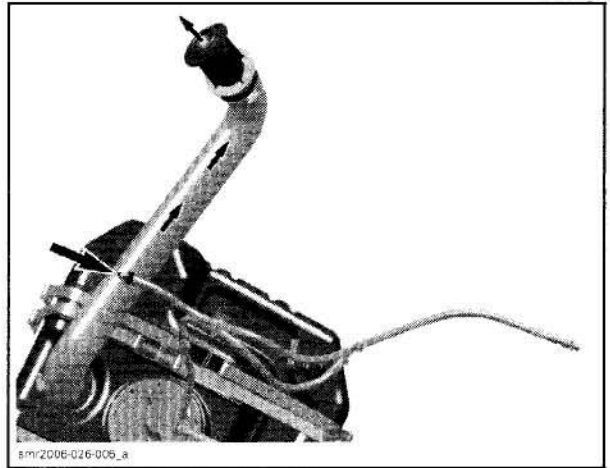

Ensure to reinstall inlet valve in its grommet.

**High Pressure Test (fuel pump circuit)**

Refer to *FUEL PUMP PRESSURE TEST* below.

**FUEL PUMP PRESSURE TEST**

Before proceeding to the pressure test ensure the battery is fully charged. Battery voltage must be over 12 volts.

Release the fuel pressure in the system using B.U.D.S. Look in the **Activation** tab.

**⚠ WARNING**

The fuel hose may be under pressure. Cover the fuel line connection with an absorbent shop rag. Slowly disconnect the fuel hose to release the pressure. Wipe off any fuel spillage inside bilge.

The pressure test will show the available pressure at the fuel pump outlet. It validates the pressure regulator, the fuel pump and leaks in the system.

Remove glove box to have access to fuel pump. Refer to *HULL/BODY* section.

Remove air vent tube from front storage area.

Ensure there is no leak from hoses and fittings. Repair any leak.

Ensure there is enough gas in fuel tank.

Disconnect outlet hose from fuel pump.

Install fuel pressure gauge (P/N 529 035 591) between disconnected hose (inline installation).



## Section 05 FUEL SYSTEM

### Subsection 01 (FUEL TANK AND FUEL PUMP)

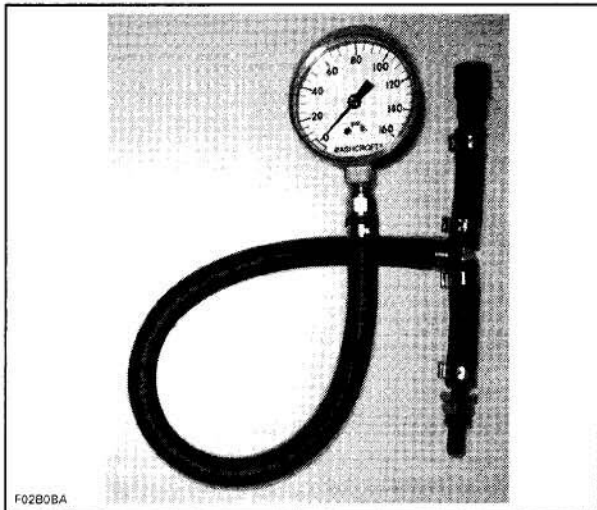

FUEL PRESSURE GAUGE

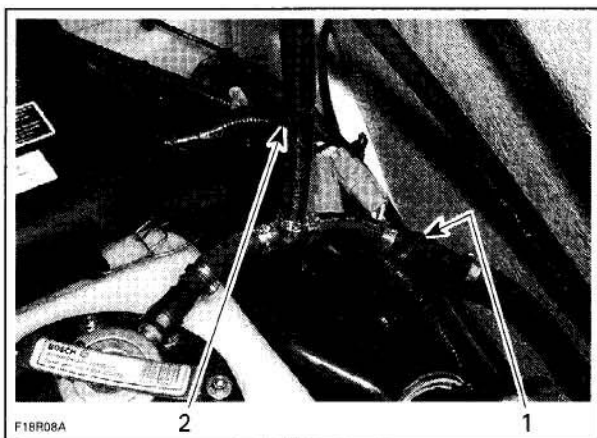

1. Hose disconnected from fuel pump
2. In-line installation of fuel pressure gauge

Install safety lanyard and observe fuel pressure. **Do not crank engine.** Repeat twice. Release pressure using B.U.D.S. between tests so that the gauge is "reset" to zero (0).

MODELS	FUEL PRESSURE (when installing safety lanyard)
4-TEC naturally aspirated/supercharged	290 - 310 kPa (42 - 45 PSI)
4-TEC supercharged intercooled	386 - 414 kPa (56 - 60 PSI)

**Crank or start engine** and observe fuel pressure. The fuel pressure should be the same as above.

If pressure is good, fuel pump and pressure regulator are working adequately.

A rapid pressure drop indicates leakage either from the fuel rail or from the fuel pump check valve. Check fuel rail for leaks. If it occurs while installing safety lanyard on DESS and fuel rail is not leaking, then replace fuel pump.

A slow pressure drop indicates leakage either from the fuel injector or from the fuel pressure regulator. Check fuel injector for leaks (see below). If it is not leaking then replace fuel pump module.

Release fuel pressure in the system using B.U.D.S. Look in the **Activation** tab.

Remove pressure gauge and reinstall fuel hose.

#### **⚠ WARNING**

Wipe off any fuel spillage in the bilge. Fuel is flammable and explosive under certain conditions. Always work in a well ventilated area.

Reinstall removed parts.

## PROCEDURES

### FUEL HOSES AND OETIKER CLAMPS

#### Inspection

Inspect all fuel hoses for wear or cracks.

Inspect all clamps for tightness.

#### Replacement

When replacing the fuel lines on all SEA-DOO models be sure to use "A1" type for pressurized hoses and "B1" type for ventilation hoses. These hoses are available from BRP. This will ensure continued proper and safe operation.

#### **⚠ WARNING**

Use of improper fuel lines could compromise fuel system integrity.

To secure or cut Oetiker clamps **no. 1** on fuel lines, use pliers (P/N 295 000 070).

## Section 05 FUEL SYSTEM

### Subsection 01 (FUEL TANK AND FUEL PUMP)

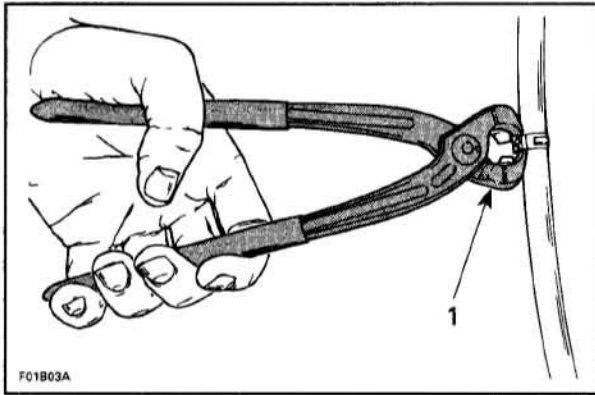

1. Cutting clamp

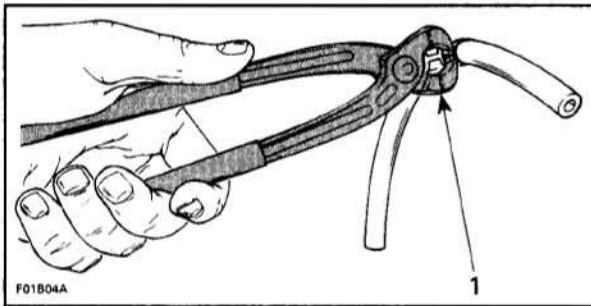

1. Securing clamp

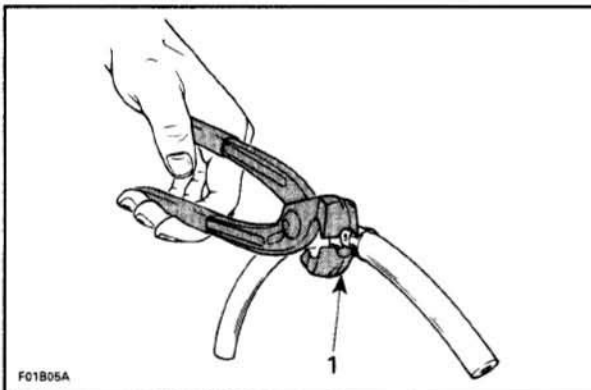

1. Securing clamp in limited access

## FUEL FILTER

### Removal

**NOTE:** The fuel filter does not require replacement under normal operating conditions. Replace only if permanently clogged or damaged. The fuel pump assembly has to be removed from the fuel tank to have access to the fuel filter.

Remove fuel pump. Refer to *FUEL PUMP* for the procedure.

Turn fuel pump upside down. Using a small flat screwdriver, remove the fuel filter by prying the inner plastic ring.

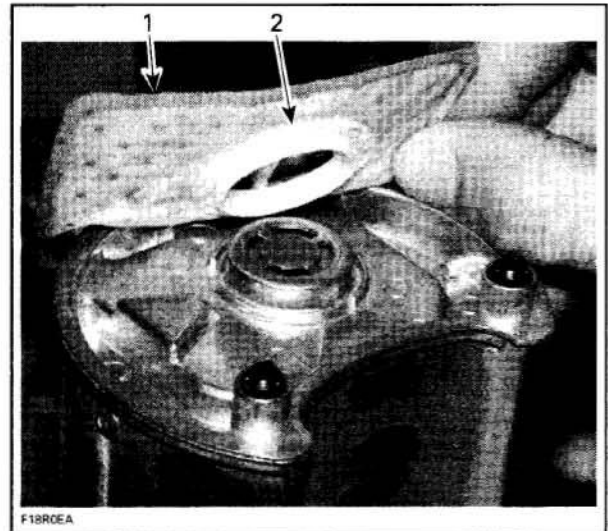

1. Fuel filter  
2. Inner plastic ring

### Inspection

Check if particles are present in fuel filter. If so, replace it.

### Installation

New filter can be pressed back on by hand. Ensure it is fully seated for complete filtering of the fuel.

Reinstall fuel pump.

## FUEL TANK

### Inspection

#### Fuel Filler Hose

Verify fuel filler hose **no. 15** for wear or cracks. Always ensure that clamps **no. 16** are well positioned and tightened. Torque clamps to 4 N•m (35 lbf•in).

#### Fuel Tank Straps

Inspect retaining straps for wear or cracks.

#### Fuel Tank

Inspect fuel tank for wear caused by any abnormal contact or rubbing with other component(s).

Disconnect fuel filler hose.

Visually inspect the inside and outside of the fuel tank necks for crack(s). If crack(s) are existing, replace fuel tank **no. 6**.



## Section 05 FUEL SYSTEM

### Subsection 01 (FUEL TANK AND FUEL PUMP)

Check with your finger to feel the inside and outside surfaces of fuel tank. Flex fuel tank necks to ensure there are no hidden cracks.

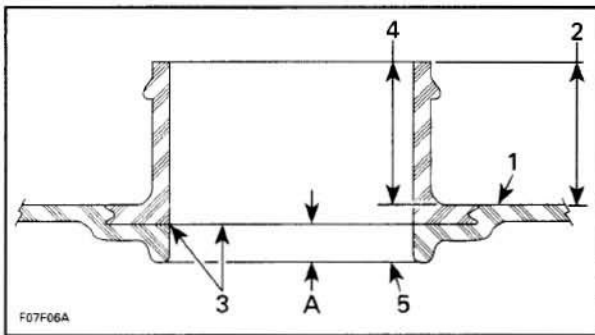

1. Tank upper surface
  2. Inspect outside, above upper surface
  3. Normal molding seam
  4. Inspect inside, above upper surface
  5. Base of the neck
- A. Approx. 4 mm (5/32 in)

**NOTE:** A fuel tank is comprised of 2 components: the tank and the filler neck. The necks are injection molded and the tank is then blow molded over the necks. During the molding process, a small molding seam may appear on the inner side of the necks at approximately 4 mm (5/32 in) from the base of the neck. It is a normal situation to have a molding seam and it should not be confused with a crack.

#### Removal

The engine removal is necessary to remove fuel tank.

Siphon fuel tank.

#### Models with MPEM besides Engine

Disconnect MPEM connectors.

Detach MPEM assembly and support from bilge. Remove TOPS switch from electrical harness or MPEM bracket.

#### All Models

Remove air intake silencer. Refer to *AIR INTAKE SYSTEM* subsection.

From storage compartment disconnect fuel pump connections.

Remove fuel pump no. 5 from fuel tank no. 6. Refer to *FUEL PUMP*.

Detach reverse system support.

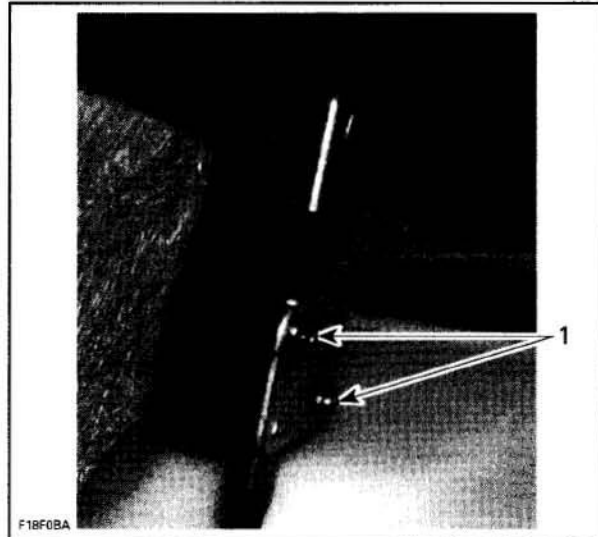

1. Screws

#### Models with MPEM besides Engine

Remove battery. Refer to *CHARGING SYSTEM* subsection.

#### All Models

Disconnect fuel tank connections.

Cut locking ties as required to release wiring harness.

Detach straps no. 13 with hook tool (P/N 529 035 989).

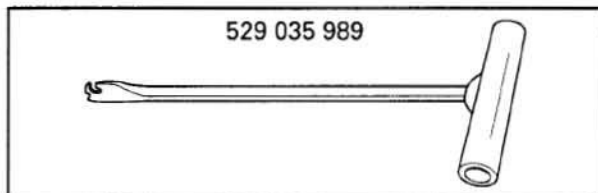

Remove fuel tank from the vehicle.

Verify hull and rubber pad for wear.

#### **WARNING**

Check that fiberglass is not exposed.

#### Installation

Ensure rubber carpets no. 19 are in place.

Insert tank, air box and straps.

Place straps in clips (bottom) and in guides of air box. Use tape to hold straps on the top of fuel tank.

Insert strap ends in hooks.

Properly secure harnesses.

Reinstall all other removed parts.

## Section 05 FUEL SYSTEM

### Subsection 01 (FUEL TANK AND FUEL PUMP)

Perform a fuel system leak test. See procedure in *INSPECTION*.

## FUEL PUMP

### Test

**NOTE:** See also the *FUEL PUMP DIAGNOSTIC FLOW CHART* further.

When connecting the safety lanyard to the DESS post, the fuel pump should run for 2 seconds to build up the pressure in the system.

If the pump does not work, disconnect the connector from the fuel pump.

Install a temporary connector on the fuel pump with wires long enough to make the connection outside the bilge.

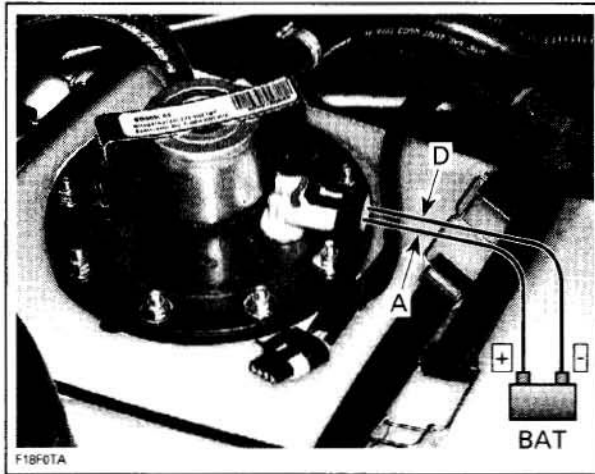

**CAUTION:** Running pump a few minutes with reverse polarity can damage the pump.

If pump does not run, replace the fuel pump module.

Otherwise, probe terminals as shown.

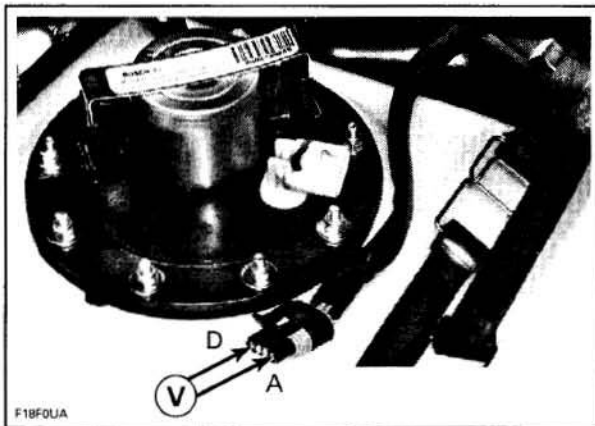

When installing safety lanyard, you should read battery voltage for approximately 2 seconds (then voltage will drop to approximately 11 V).

If battery voltage is read, the problem can be in fuel pump or in harness connector. Repair or replace appropriate part.

If battery voltage is not read, probe terminals as shown.

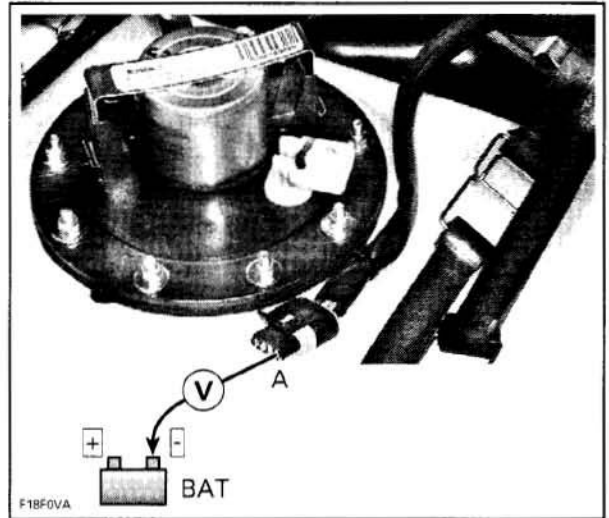

- If battery voltage is read, check continuity of circuit B-29 going towards ECM. If it is good, try a new ECM.
- If battery voltage is not read, check continuity of circuit 1-26 going towards MPEM. If it is good, try a new MPEM.

### Removal

Open front storage compartment cover.

Remove the storage basket (if so equipped).

Remove front access panel (see *HULL/BODY* section).

Remove front vent tubes.

Remove glove box (see *HULL/BODY* section).

Disconnect electrical connector.

Disconnect vent tube from fuel pump.

Release the fuel pressure in the system using B.U.D.S. Look in the **Activation** tab.

Disconnect inlet hose from fuel pump.

From glove box opening, remove fuel pump retaining nuts.



## Section 05 FUEL SYSTEM

### Subsection 01 (FUEL TANK AND FUEL PUMP)



**CAUTION:** While pulling out the fuel pump, pay attention to fuel sensor float arm. Float arm can get stuck and bend which can reduce the fuel sensor capabilities.

Pull fuel pump out from glove box opening.

#### **WARNING**

Always wipe off any fuel spillage from the watercraft. While dealing with fuel or fuel system always work in well ventilated area.

### Installation

Align tab of gasket with tank neck and then align arrow of fuel pump with tab of gasket.

Refer to following illustration for tightening sequence. Torque 1 to 4 at 1 N•m (9 lbf•in) and then 5 to 13 at 2 N•m (18 lbf•in).

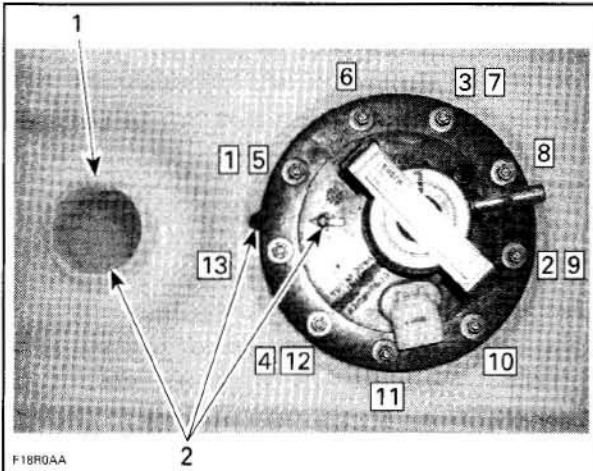

#### **TIGHTENING SEQUENCE**

1. Fuel tank neck
2. Align

Perform a fuel system leak test. See procedure in *INSPECTION*.

**Section 05 FUEL SYSTEM**  
Subsection 01 (FUEL TANK AND FUEL PUMP)

Fuel Pump Diagnostic Flow Chart

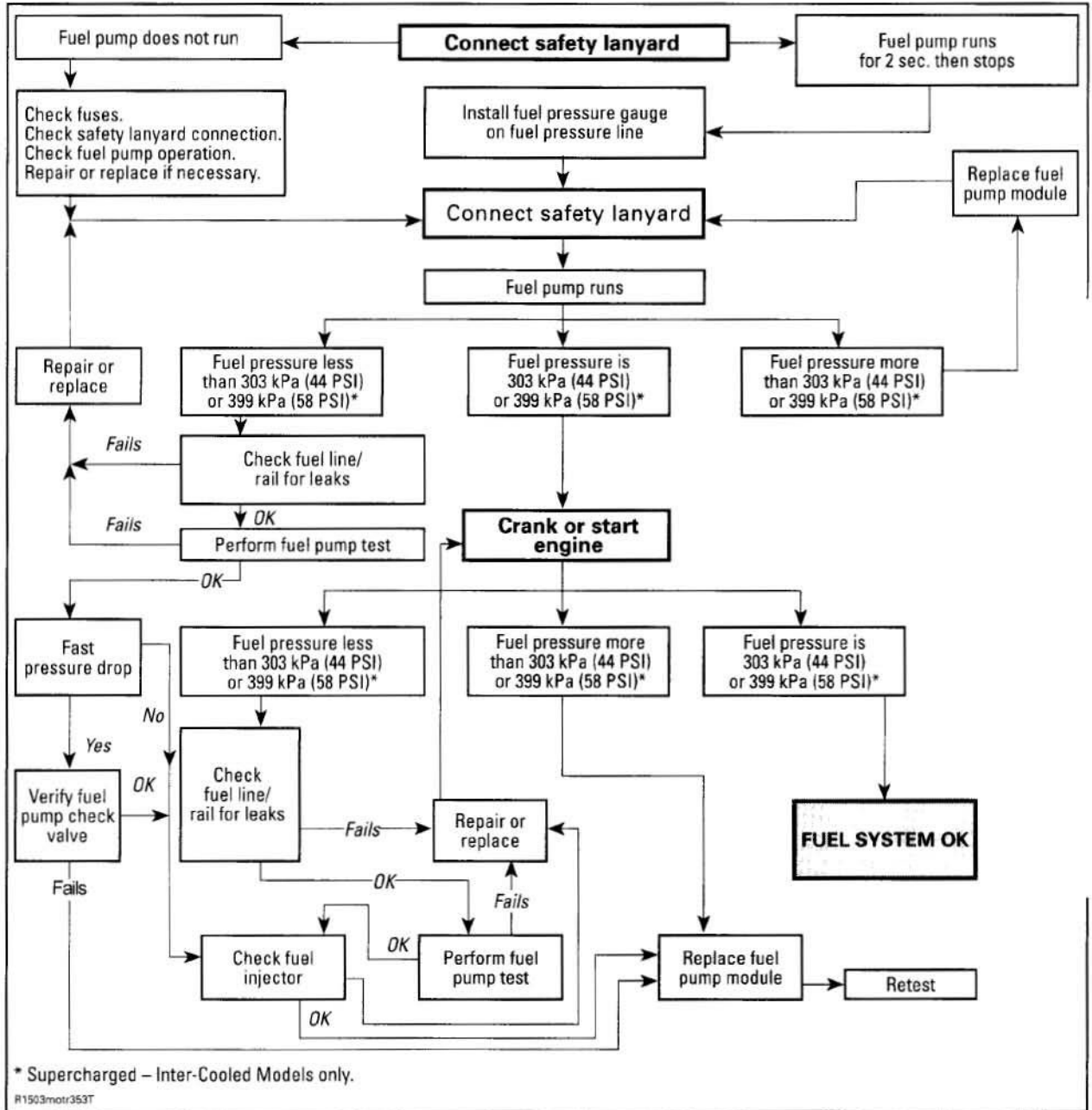



# IGNITION SYSTEM

## SERVICE TOOLS

<b>Description</b>	<b>Part Number</b>	<b>Page</b>
ECM adapter.....	420 277 010 .....	222

## SERVICE PRODUCTS

<b>Description</b>	<b>Part Number</b>	<b>Page</b>
silicone lubricant.....	293 600 041 .....	222

**Section 06 ELECTRICAL SYSTEM**  
**Subsection 01 (IGNITION SYSTEM)**

**Ignition System Wiring Diagram**

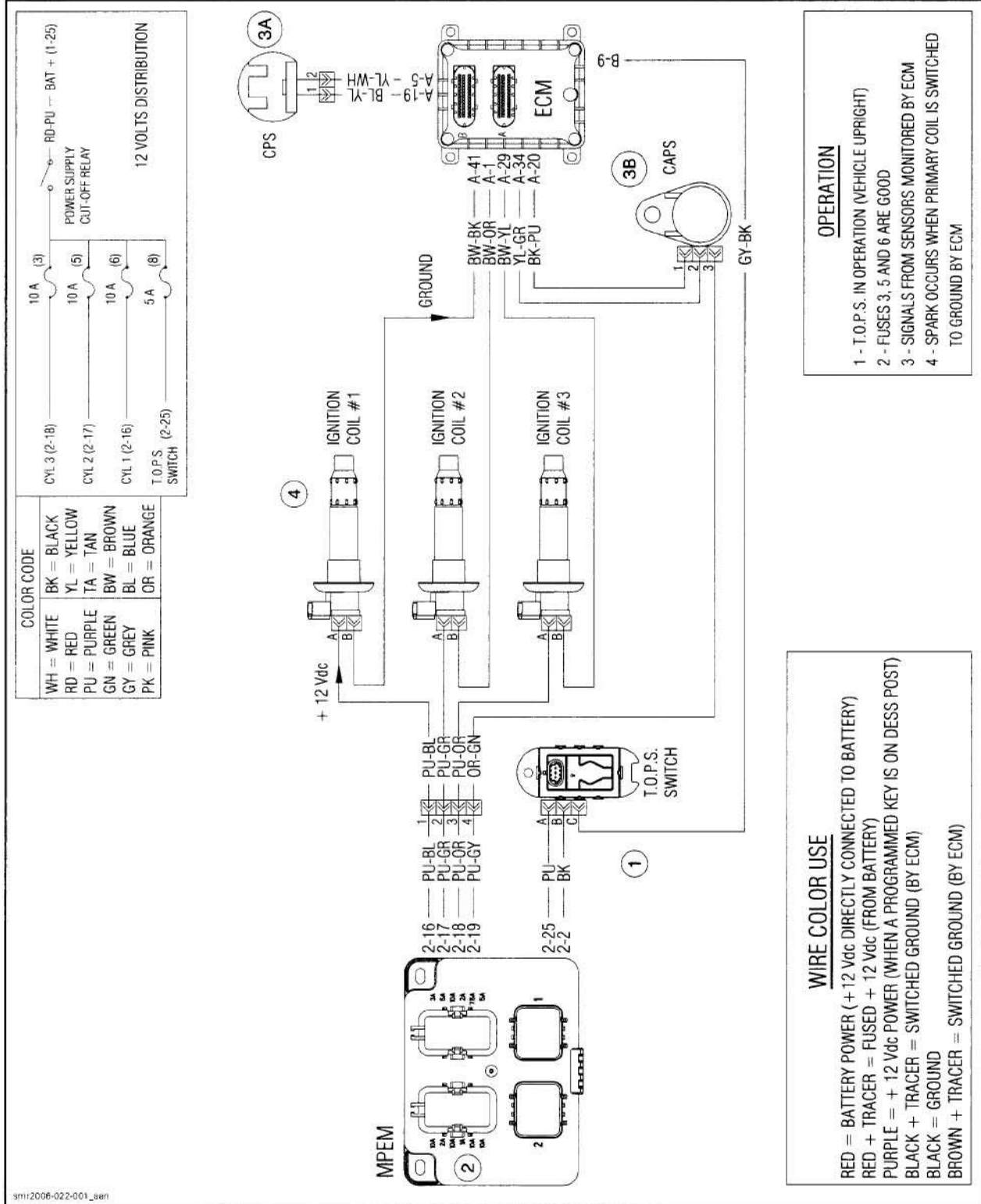



## GENERAL

**NOTE:** It is a good practice to check for fault codes using B.U.D.S. software as a first troubleshooting step. Refer to *EMS DIAGNOSTIC AND COMMUNICATION TOOLS*.

**NOTE:** The EMS controls the ignition system. For more information, refer to *ENGINE MANAGEMENT*.

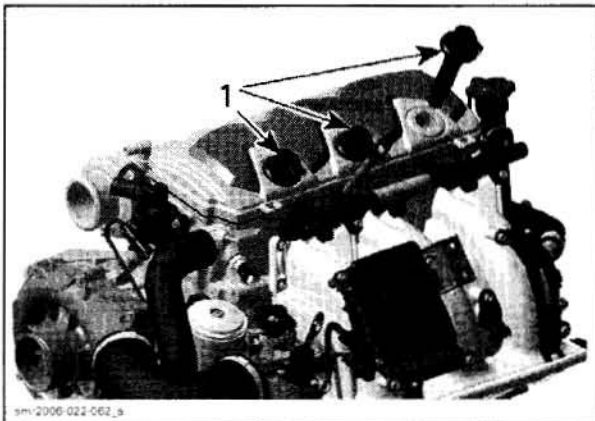

1. Ignition coil

**NOTE:** The MPKM energizes the primary side of each ignition coil individually while the ECM completes the circuit by switching it to the ground at the right moment. The ECM can detect open and short circuit in the primary winding but it does not check the secondary winding.

### **⚠ WARNING**

Never check for engine ignition spark from an open coil and/or spark plug in the engine compartment as spark may cause potential fuel vapor to ignite.

**CAUTION:** Do not remove the ignition coil before disconnecting the connector, or the wires will be damaged. Do not pry up ignition coil with a screwdriver to avoid damage.

## PROCEDURES

### IGNITION COIL

#### Quick Test with B.U.D.S.

Using the B.U.D.S. software, energize the ignition coil.

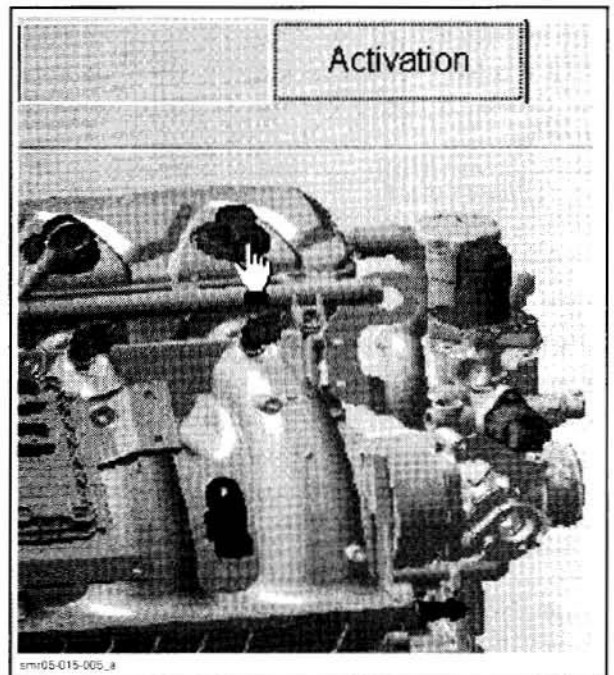

You should hear the spark occurring. In doubt, use an inductive spark tester or a sealed tester - available from tool suppliers to prevent spark occurring in the bilge. If there is no spark, perform the following checks.

**NOTE:** Keep in mind that even if there is a spark during this static test, voltage requirement is higher to produce a spark in the combustion chamber when engine is running. Ignition coil could be not working in real operation. Replacing ignition coil may be necessary as a test.

#### Voltage Test

Disconnect the connector from the ignition coil and check the voltage supplied by the MPKM.

Install safety lanyard on the DESS post. Read voltage.

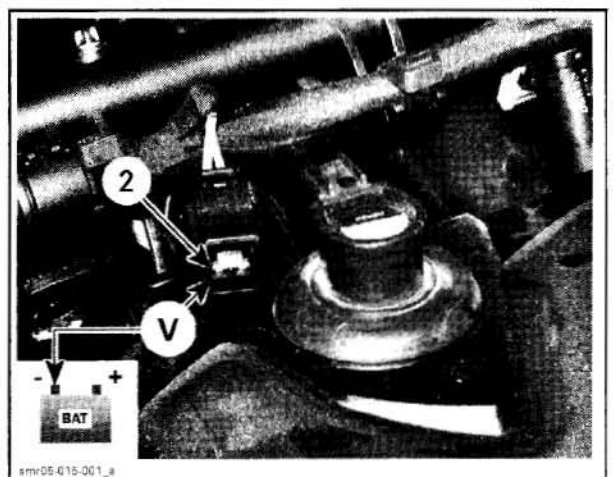

**Section 06 ELECTRICAL SYSTEM**  
**Subsection 01 (IGNITION SYSTEM)**

The voltage should be 12 V.

If 12 V is NOT read, check continuity of appropriate circuit. If wiring harness is good, try a new MPEM.

COMPONENT	CIRCUIT NUMBER
Cylinder 1	2 - 16
Cylinder 2	2 - 17
Cylinder 3	2 - 18

If 12 V is read, disconnect the ECM connector "A" and check the continuity of appropriate circuit.

**NOTE:** For this test, use the ECM adapter (P/N 420 277 010) to probe ECM connector. Refer to *ENGINE MANAGEMENT* for more information.

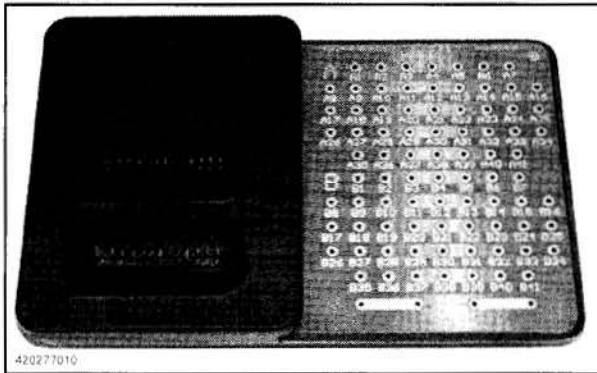

COMPONENT	CIRCUIT NUMBER
Cylinder 1	41
Cylinder 2	1
Cylinder 3	29

If wiring harness is defective, repair the connector or replace the wiring harness between ECM connector and the ignition coil.

If wiring harness is good, try a new ECM.

**Resistance Test**

An ignition coil with good resistance measurement can still be faulty. Voltage leak can occur at high voltage level which is not detectable with an ohmmeter. Replacing the ignition coil may be necessary as a test.

Remove ignition coil from spark plug.

Using a multimeter, check the resistance in both primary and secondary windings.

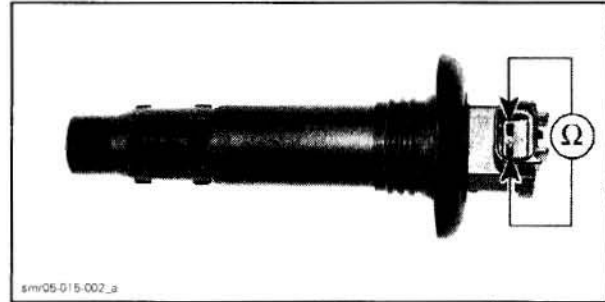

PRIMARY CIRCUIT

CIRCUIT	TERMINAL	RESISTANCE @ 20°C (68°F)
Primary	1 and 2	0.85 - 1.15 Ω

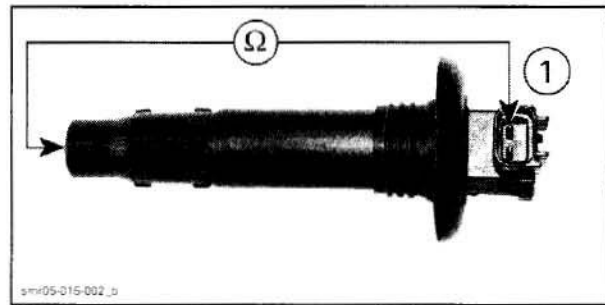

SECONDARY CIRCUIT

CIRCUIT	TERMINAL	RESISTANCE @ 20°C (68°F)
Secondary	1 and spark plug terminal	9.5 - 13.5 kΩ

If any resistance is not good, replace ignition coil. If the windings test good, try a new ECM.

**NOTE:** Prior to inserting the ignition coil to its location, apply some silicone lubricant (P/N 293 600 041) as shown. After installation, ensure the seal seats properly with engine top surface.

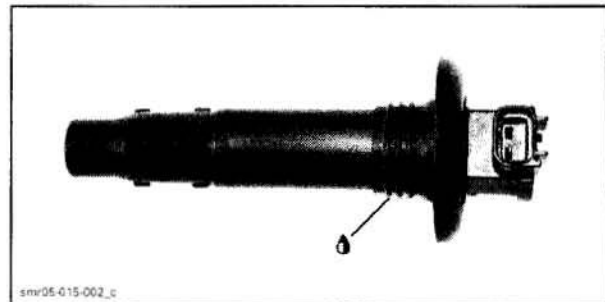



**Section 06 ELECTRICAL SYSTEM**  
**Subsection 01 (IGNITION SYSTEM)**

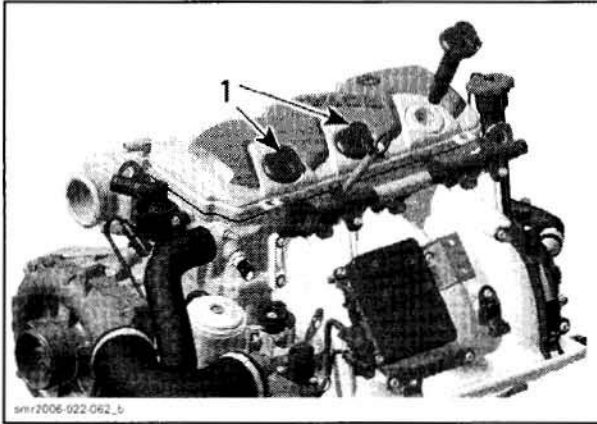

1. Seal properly seated

**SPARK PLUGS**

**Disassembly**

Remove engine cover.

Disconnect the electrical connector from the ignition coil.

Remove the ignition coil.

**⚠ WARNING**

Never remove ignition coil from the spark plug without disconnecting it from the wiring harness. Flammable vapors may be present in the bilge and ignited by a spark which could cause an explosion.

Unscrew the spark plug one turn.

Clean the spark plug and cylinder head with pressurize air.

Unscrew spark plug then use the ignition coil to take spark plug out of spark plug hole.

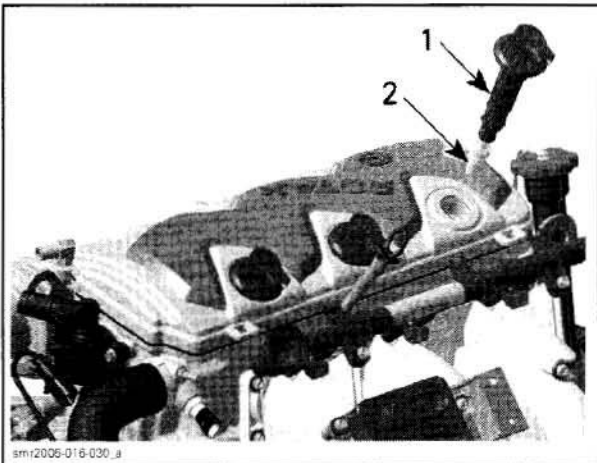

1. Ignition coil  
 2. Spark plug

**Spark Plug Installation**

Prior to installation make sure that contact surfaces of the cylinder head and spark plug are free of grime.

1. Using a wire feeler gauge, set electrode gap according to the following chart.
2. Apply anti-seize lubricant over the spark plug threads to prevent possible seizure.
3. Hand screw spark plug into cylinder head. Then, tighten the spark plug clockwise an additional 1/4 turn with a proper socket.

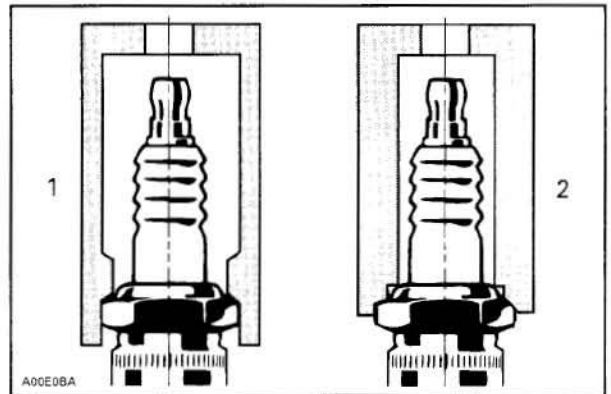

1. Proper socket  
 2. Improper socket

ENGINE	SPARK PLUG	TORQUE	GAP mm (in)
All 4-TEC	NGK DCPR8E	Hand tighten + 1/4 turn with a socket	0.75 (.030)

# CHARGING SYSTEM

## SERVICE TOOLS

<b>Description</b>	<b>Part Number</b>	<b>Page</b>
3-pin magneto harness adapter .....	529 036 016 .....	229–230
engine leak test kit .....	295 500 352 .....	231
multimeter Fluke 111 .....	529 035 868 .....	227



**Section 06 ELECTRICAL SYSTEM**  
**Subsection 02 (CHARGING SYSTEM)**

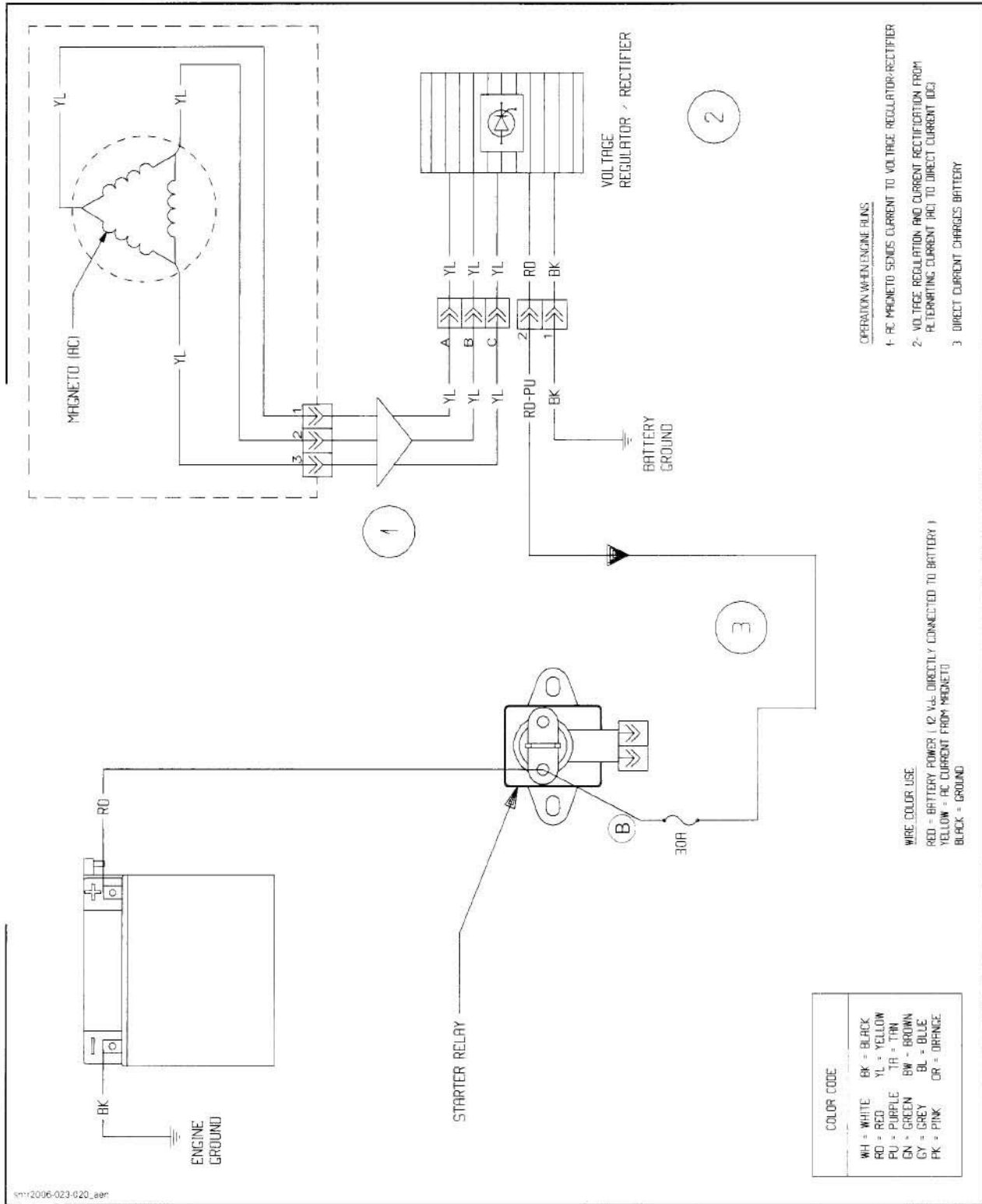

**Section 06 ELECTRICAL SYSTEM**  
Subsection 02 (CHARGING SYSTEM)

**GENERAL**

The purpose of the charging system is to keep the battery at a full state of charge.

**Magneto**

The magneto is the primary source of electrical energy. It transforms magnetic field into electric current (AC).

The magneto has a 3 phase-delta wound stator on 18 poles. Capacity is 380 watts.

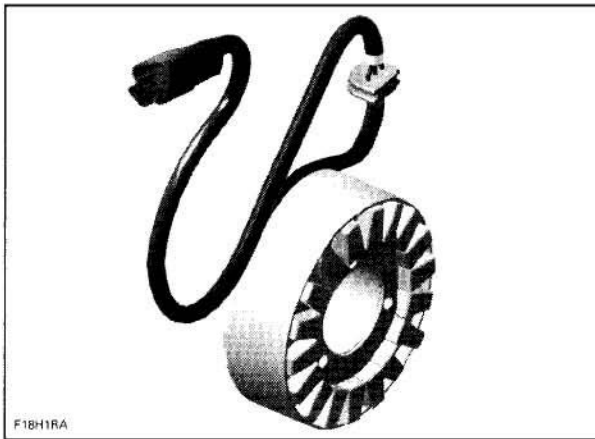

**Rectifier/Regulator**

The rectifier receives AC current from the magneto and transforms it into direct current (DC).

The regulator, included in the same unit, limits voltage at a maximum level (14.5 to 14.8 volts) to prevent any damage to electrical components.

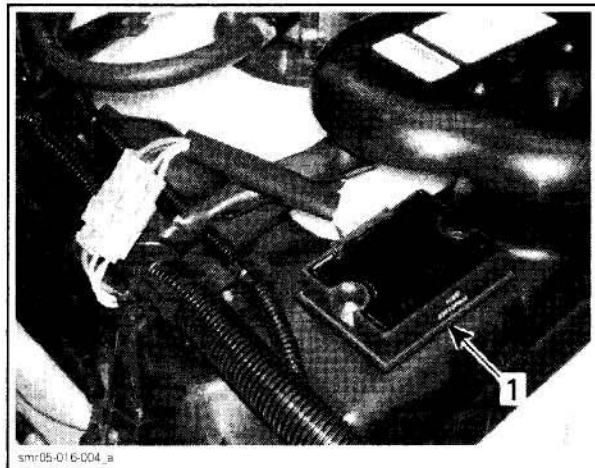

1. Rectifier/Regulator

**Battery**

The battery is the DC source for the electric starter, the MPEM, ECM and all accessories.

**Fuse**

If the battery is regularly discharged, check charging system fuse condition.

**NOTE:** The fuse holder for the charging fuse is located beside the MPEM.

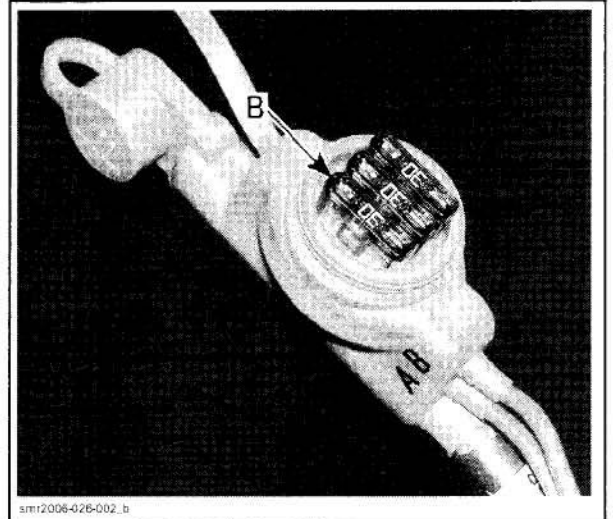

B. Charging system fuse

The rectifier/regulator could be the culprit of a blown fuse. To check, simply disconnect the rectifier/regulator from the circuit.

If the fuse still burns, check for a defective wire.

**CAUTION:** Do not use a higher rated fuse as this cause severe damage.

**TESTING PROCEDURE**

First ensure that battery is in good condition prior to performing the following tests.

For best results, use the multimeter Fluke 111 (P/N 529 035 868).





**Section 06 ELECTRICAL SYSTEM**  
**Subsection 02 (CHARGING SYSTEM)**

**RECTIFIER/REGULATOR**

**Continuity Test**

Due to internal circuitry, there is no static test available to check continuity.

**Current Test**

Remove charging system fuse.

**NOTE:** The fuse holder for the charging fuse is located beside the MPEM.

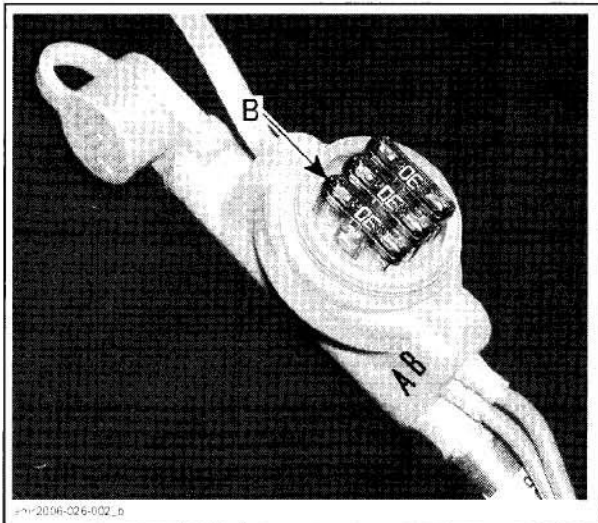

B. Charging system fuse

Set multimeter to Adc.

Connect probes to fuse holder terminals.

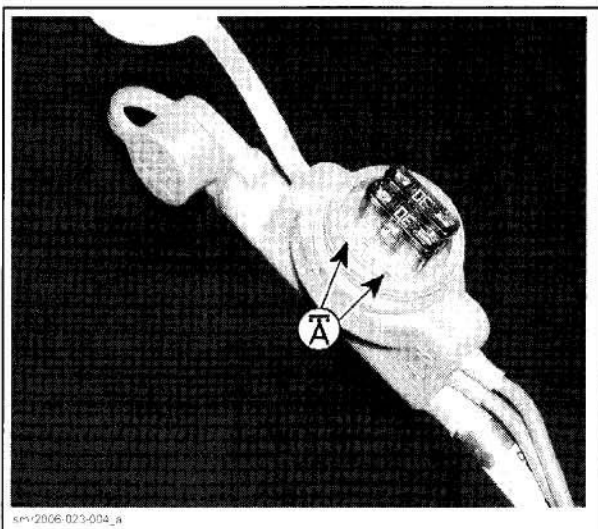

Start engine.  
 Read current.

TEST ENGINE SPEED	CURRENT (DC)
6000 RPM	5 A min.

If current is below specification, check magneto (stator) output prior to concluding that rectifier is faulty.

**Voltage Test**

Set multimeter to Vdc scale.

Connect multimeter to battery posts.

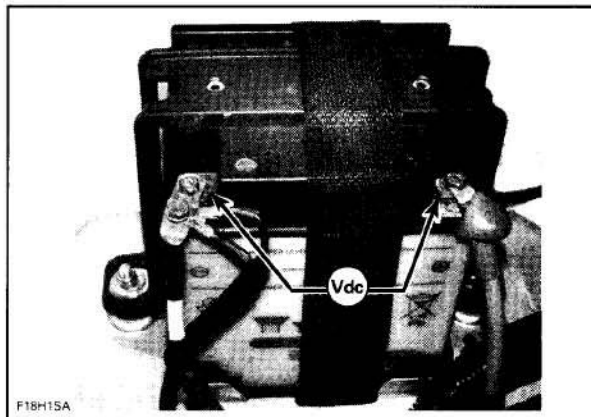

Start engine.  
 Read voltage.

TEST ENGINE SPEED	VOLTAGE (DC)
5500 RPM	15 V max.

If voltage is above specification, replace rectifier/regulator.

**NOTE:** If it is continually necessary to add distilled water to the battery, this indicates an over voltage situation, requiring replacement of the rectifier/regulator. If the battery will not stay charged, the problem can be any of the charging system components. If these all check good, try a new rectifier/regulator.

**STATOR**

**Continuity Test**

Disconnect the magneto wiring harness connector.

**Section 06 ELECTRICAL SYSTEM**  
**Subsection 02 (CHARGING SYSTEM)**

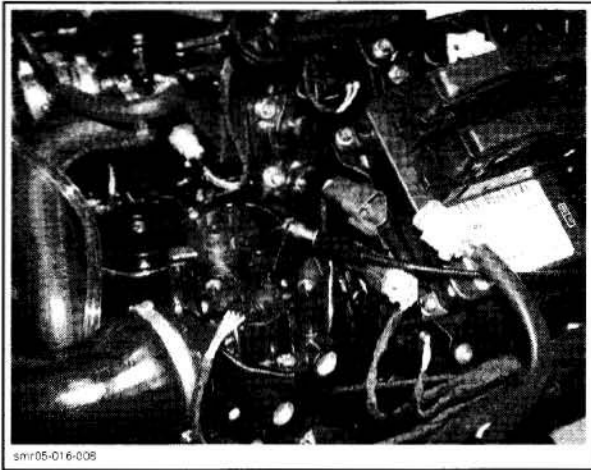

Install the 3-pin magneto harness adapter (P/N 529 036 016) between unplugged connectors.

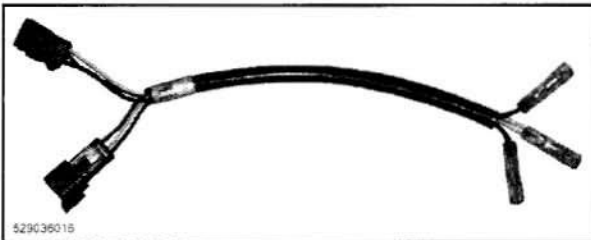

Set multimeter to  $\Omega$ .  
 Connect multimeter between YELLOW wires.

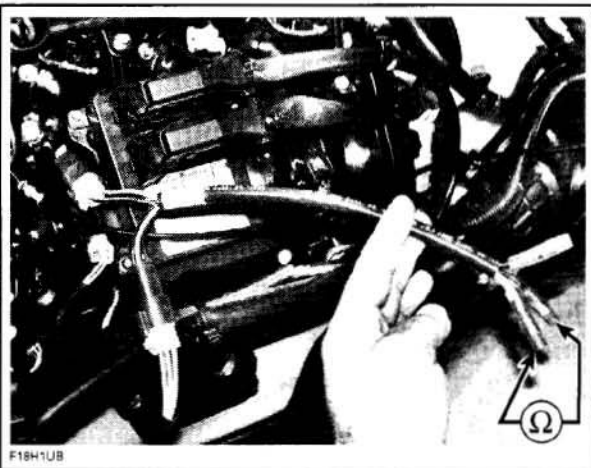

Read resistance.

TERMINAL	RESISTANCE @ 20°C (69°F)
1 and 2	0.1 - 1 $\Omega$
1 and 3	
2 and 3	

If any result is out of specification, replace stator.

**Insulation Test**

Disconnect the magneto wiring harness connector.

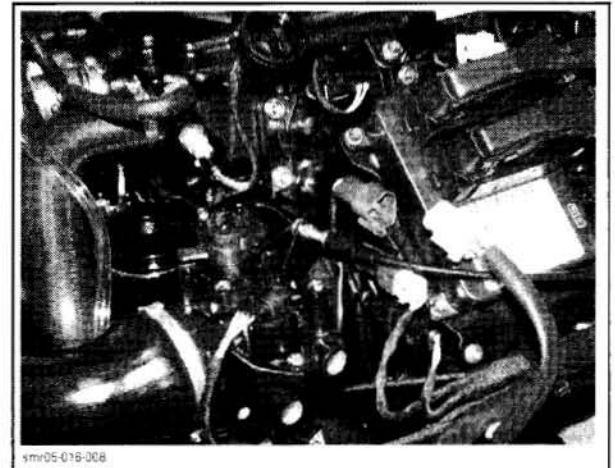

Install the 3-pin magneto harness adapter (P/N 529 036 016) to the magneto wiring harness.

**IMPORTANT:** Leave wiring harness side disconnected.

Set multimeter to  $\Omega$ .

Connect multimeter to a YELLOW wire and engine ground.

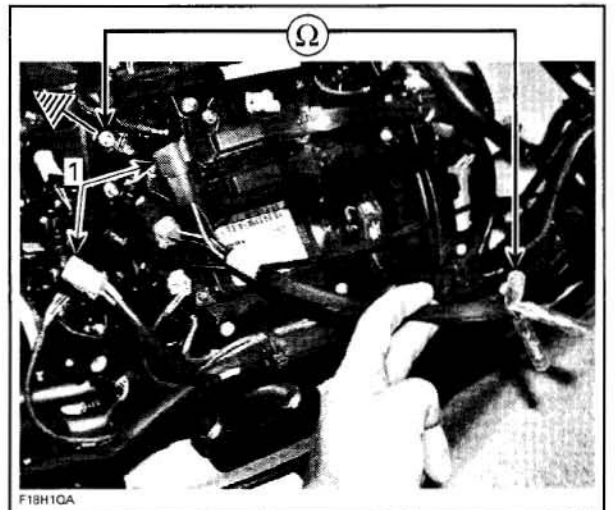

1. These connectors not plugged for this test

Read resistance.



**Section 06 ELECTRICAL SYSTEM**  
**Subsection 02 (CHARGING SYSTEM)**

TERMINAL	RESISTANCE @ 20°C (69°F)
Any YELLOW wire and engine ground	Infinity (open circuit)

Repeat test for the other yellow wires.

If there is a resistance or continuity, the stator coils and/or the wiring is grounded and need to be repaired or replaced.

**Voltage Test**

Disconnect the voltage regulator/rectifier connectors.

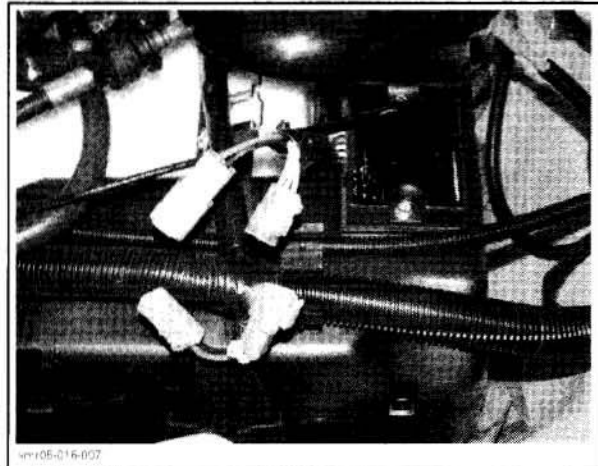

Disconnect the magneto wiring harness connector.

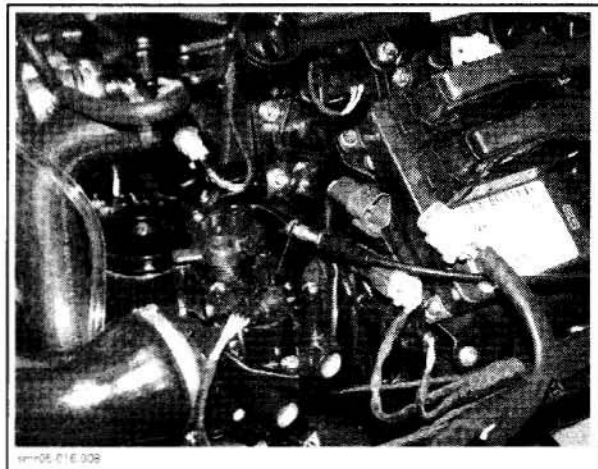

Install the 3-pin magneto harness adapter (P/N 529 036 016) between unplugged connectors.

Set multimeter to Vac scale.

Connect multimeter between YELLOW wires.

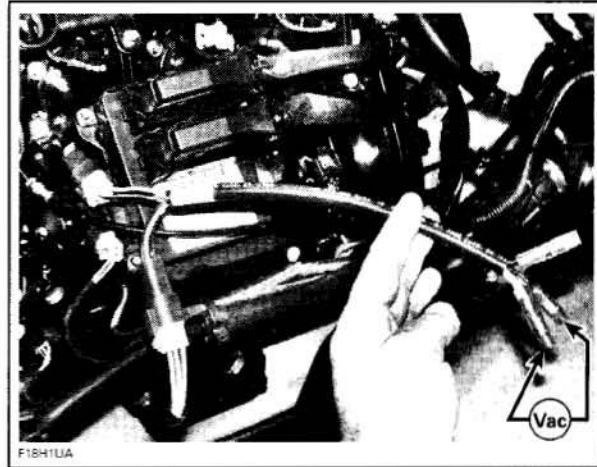

Start engine.

Read voltage.

TEST ENGINE SPEED	TERMINAL	VOLTAGE (AC)
3500 RPM	1 and 2	Approx. 25 V
	1 and 3	
	2 and 3	

If voltage is lower than specification, replace stator.

**BATTERY**

**Troubleshooting**

<b>SYMPTOM: DISCHARGED OR WEAK BATTERY</b>	
CAUSE	REMEDY
Battery posts and/or cable terminal oxidized.	Clean and coat with dielectric grease.
Loose or bad connections.	Check wiring and connector cleanliness, damaged or short circuit.
Faulty battery (sulfated, doesn't keep a full charge, damaged casing, loose post).	Replace.
Burnt fuse(s) or faulty rectifier.	First check fuse(s). If it is in good condition, check rectifier/regulator.
Faulty battery charging coil (or stator).	Check and replace.

## Section 06 ELECTRICAL SYSTEM

### Subsection 02 (CHARGING SYSTEM)

#### Removal

#### **⚠ WARNING**

Battery BLACK negative cable must always be disconnected first and connected last. Never charge or boost battery while installed in watercraft.

Proceed as follows:

- Disconnect the BLACK negative cable first.
- Disconnect the RED positive cable last.
- Remove the vent line from the battery.
- Remove the holding strap(s).
- Withdraw battery from watercraft being careful not lean it so that electrolyte flows out of vent elbow.

#### **⚠ WARNING**

Electrolyte is poisonous and dangerous. Avoid contact with eyes, skin and clothing. Wear a suitable pair of non-absorbent gloves when removing the battery by hand.

**CAUTION:** Should any electrolyte spillage occur, immediately wash off with a solution of baking soda and water.

#### Cleaning

Clean the battery casing, caps, cables and battery posts using a solution of baking soda and water.

**CAUTION:** Do not allow cleaning solution to enter battery.

Remove corrosion from battery cable terminals and battery posts using a firm wire brush. Rinse with clear water and dry well.

#### Inspection

Visually inspect battery casing for cracks or other possible damage. If casing is damaged, replace battery and thoroughly clean battery tray and close area with water and baking soda.

Inspect battery posts for security of mounting.

Inspect for cracked or damaged battery caps, replace defective caps.

**NOTE:** Hand tighten caps then tighten an additional 1/4 turn using a 20 mm (3/4 in) socket. Using other tool could damage the plastic battery caps.

#### **⚠ WARNING**

Battery electrolyte is caustic. To prevent spillage, battery cell cap should be sufficiently tight to properly seal.

#### Electrolyte Level

Check electrolyte level in each cell, add distilled water up to upper level line.

**CAUTION:** Add only distilled water in an activated battery.

#### Battery Vent and Check Valve

#### **⚠ WARNING**

Battery caps do not have vent holes. Make sure that vent line is not obstructed.

Check vent line condition.

Use pump in engine leak test kit (P/N 295 500 352).

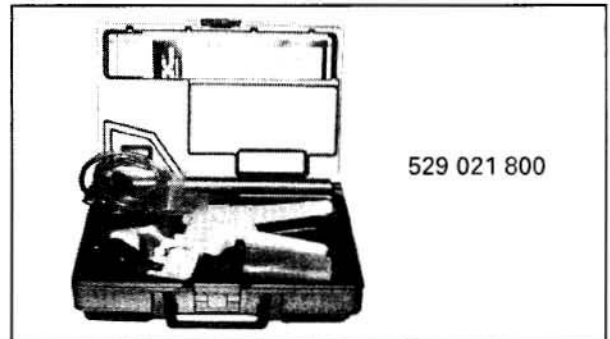

Set pump to PRESSURE and verify check valve operation as follows.

Check valve must let air to flow out when orange side is opposite to pump.

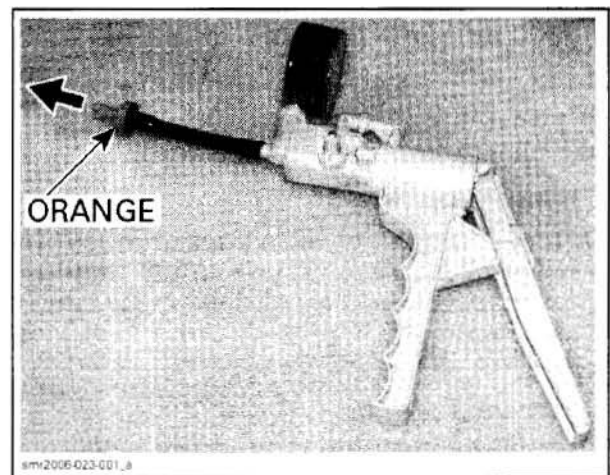

AIR MUST FLOW OUT IN THIS POSITION



**Section 06 ELECTRICAL SYSTEM**  
**Subsection 02 (CHARGING SYSTEM)**

Check valve must hold air with 34 kPa (5 PSI) without leaking when orange side is on pump side.

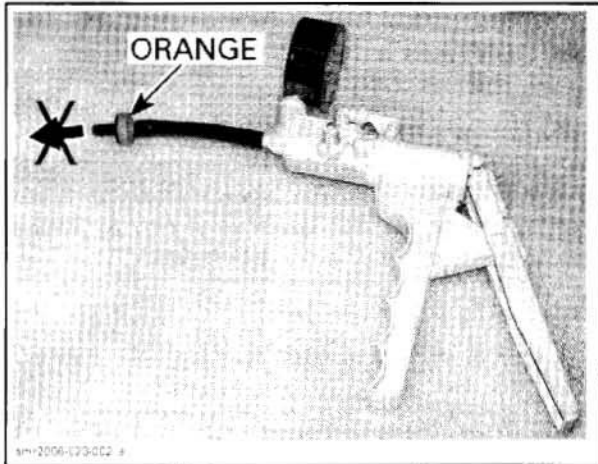

MUST HOLD AIR IN THIS POSITION

At installation, ensure to position check valve with the orange side as shown.

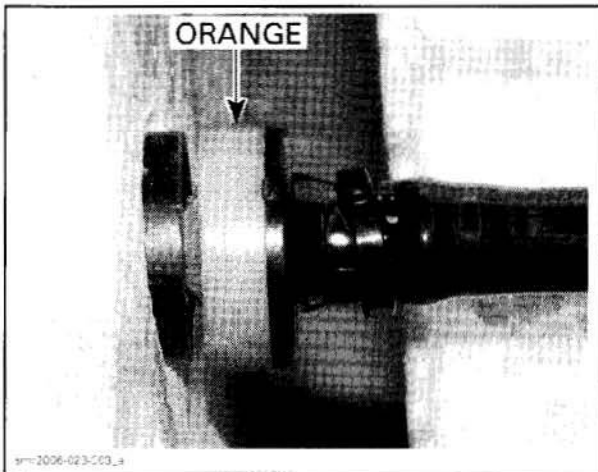

**Battery Testing**

There are 2 types of battery tests: electrolyte reading and load test. An electrolyte reading is made on a battery without discharging current. It is the simplest and commonly used. A load test gives more accuracy of the battery condition.

**Electrolyte Reading**

Check charge condition using either a hydrometer or multimeter.

Set multimeter to Vdc and measure voltage at battery posts.

BATTERY CONDITION	VOLTAGE
Fully charged	12.6 Vdc

A hydrometer measures the charge of a battery in terms of specific gravity of the electrolyte.

BATTERY CONDITION	SPECIFIC GRAVITY
Fully charged	1.265 - 1.280

Most hydrometers give a true reading at 21°C (70°F).

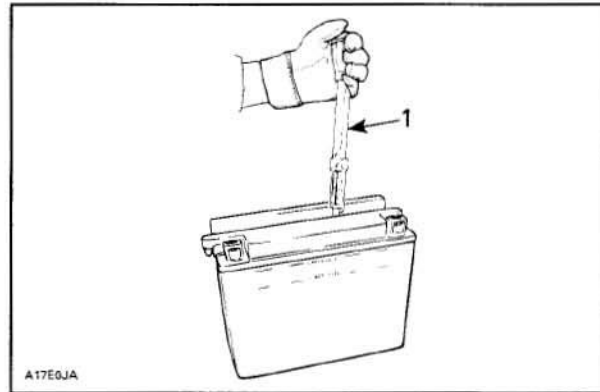

1. Specific gravity 1.265

In order to obtain correct readings, adjust the initial reading by adding .004 points to the hydrometer readings for each 5.5°C (10°F) above 21°C (70°F) and by subtracting .004 point for every 5.5°C (10°F) below 21°C (70°F).

This chart will be useful to find the correct reading.

ELECTROLYTE TEMPERATURE		OPERATION TO PERFORM	
°C	°F		
38	100	.012	Add to the reading
32	90	.008	
27	80	.004	
21	70	CORRECT READING	
16	60	.004	Subtract from the reading
10	50	.008	
4	40	.012	
- 1	30	.016	

**EXAMPLE NO. 1**

TEMPERATURE ABOVE 21°C (70°F):  
 Hydrometer reading: 1.250  
 Electrolyte temperature: - 1°C (30°F)  
 Subtract .016 Sp. Gr.  
 Corrected Sp. Gr. is 1.234

**EXAMPLE NO. 2**

TEMPERATURE ABOVE 21°C (70°F):  
 Hydrometer reading: 1.235  
 Electrolyte temperature: 38°C (100°F)  
 Add .012 Sp. Gr.  
 Corrected Sp. Gr. is 1.247

**Section 06 ELECTRICAL SYSTEM**  
**Subsection 02 (CHARGING SYSTEM)**

<b>SPECIFIC GRAVITY READING USING A HYDROMETER</b>		
<b>STATE OF CHARGE</b>	<b>ELECTROLYTE TEMPERATURE</b>	
	27°C (80°F)	4°C (40°F)
100%	1.26/1.27	1.27/1.28
75%	1.21/1.22	1.22/1.23
50%	1.16/1.17	1.17/1.18
25%	1.12/1.13	1.13/1.14
0%	1.10 or less	1.11 or less

**Load Test**

This is the best test of battery condition under a starting load. Use a load testing device that has an adjustable load.

Apply a load of 3 times the ampere-hour rating of the battery for 14 seconds, then check battery voltage.

<b>LOAD</b>	<b>VOLTAGE</b>
3 times the Ah/14 seconds	10.5 Vdc min.

**Battery Storage**

**CAUTION:** Battery storage is critical for battery life. Regularly charging the battery during storage will prevent cell sulfation. Keeping the battery in vehicle for storage may lead to contacts degradation/corrosion and case damage if freezing occurs. A discharged battery will freeze and break in area where freezing point is experienced. Electrolyte leakage will damage surrounding parts. Always remove battery from vehicle for storage and regularly charge to keep an optimal condition.

Disconnect and remove battery from watercraft as explained in *REMOVAL*.

Check electrolyte level in each cell, add distilled water up to upper level line.

**CAUTION:** Do not overfill.

The battery must always be stored in fully charged condition. If required, charge until specific gravity of 1.265 is obtained.

**CAUTION:** Battery electrolyte temperature must not exceed 50°C (122°F). The casing should not feel hot.

Clean battery terminals and cable connections using a wire brush. Apply a light coat of dielectric grease on terminals.

Clean battery casing and caps using a solution of baking soda and water.

**CAUTION:** Do not allow cleaning solution to enter battery.

Rinse battery with clear water and dry well using a clean cloth.

Store battery in a cool dry place. Such conditions reduce self-discharging and keep fluid evaporation to a minimum. Keep battery away from dew, high moisture and direct sunlight.

During the storage period, recheck electrolyte level and specific gravity readings at least every month. If necessary, keep the battery at its upper level line and near full charge as possible (trickle charge).

**Activation of a New Battery**

**⚠ WARNING**  
**Never charge or boost battery while installed in watercraft.**

Perform the following operations anytime a new battery is to be installed.

- Remove the sealing tube from the vent elbow.

**⚠ WARNING**  
**Failure to remove the sealing tube could result in an explosion.**

- Remove caps and fill battery to UPPER LEVEL line with electrolyte (specific gravity: 1.265 at 21°C (70°F)).

**NOTE:** This battery may fill slower than others due to the anti-spill check ball design.



**Section 06 ELECTRICAL SYSTEM**  
**Subsection 02 (CHARGING SYSTEM)**

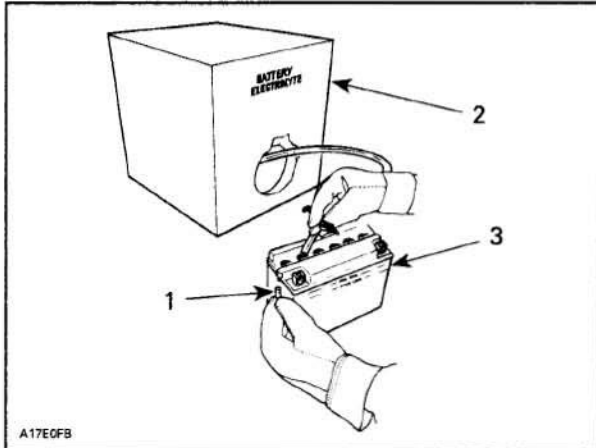

1. Sealing tube removed
2. Battery electrolyte
3. Upper level line

– Allow the battery to stand for 30 minutes MINIMUM so that electrolyte soak through battery cells.

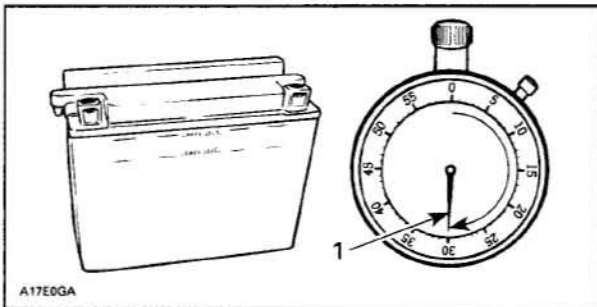

1. 30 minutes

– Readjust the electrolyte level to the UPPER LEVEL line.

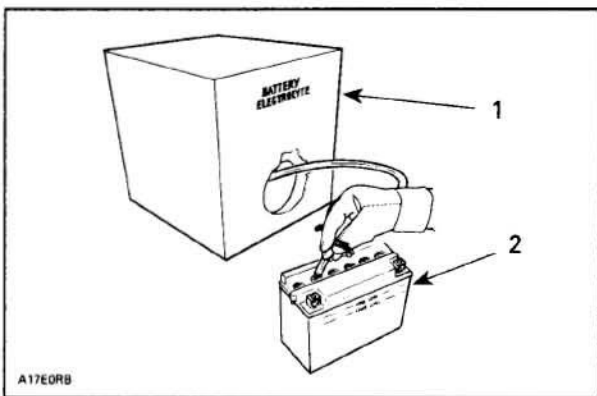

1. Battery electrolyte
2. Upper level line

– Connect a 2 A battery charger for 3 to 5 hours.

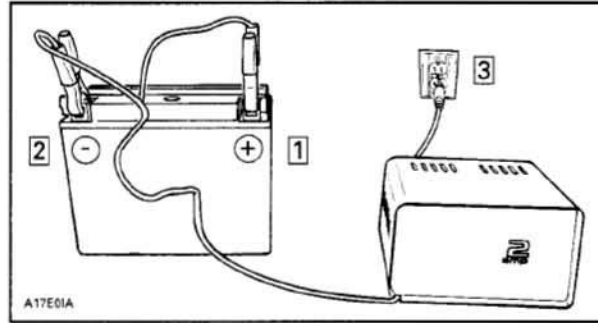

- Step 1: Connect + lead to battery + post
- Step 2: Connect - lead to battery - post
- Step 3: Plug battery charger

**⚠ WARNING**

Gases given off by a battery being charged are highly explosive. Always charge in a well ventilated area. Keep battery away from cigarettes or open flames. Always turn battery charger off prior to disconnecting cables. Otherwise a spark will occur and battery might explode.

**CAUTION:** If charging rate raises higher than 2.4 A reduce it immediately. If cell temperature rises higher than 50°C (122°F) or if the casing feels hot, discontinue charging temporarily or reduce the charging rate.

– Disconnect battery charger.

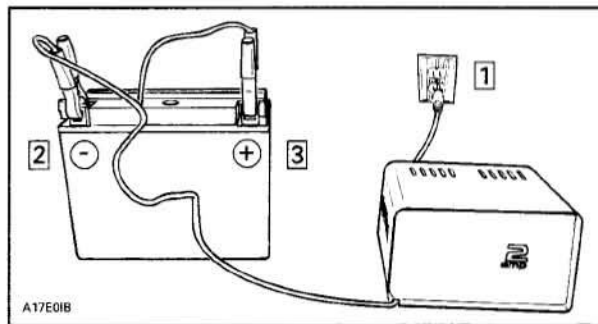

- Step 1: Unplug battery charger
- Step 2: Disconnect - lead
- Step 3: Disconnect + lead

– Test battery state of charge. Use a hydrometer.

## Section 06 ELECTRICAL SYSTEM

### Subsection 02 (CHARGING SYSTEM)

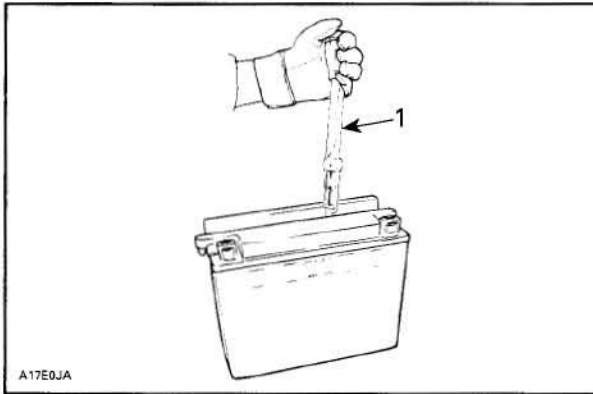

1. Specific gravity 1.265

- If electrolyte level has dropped after charging, fill with distilled water to UPPER LEVEL line. After water is added, continue charging for 1 to 2 hours to mix water with electrolyte.
- Reinstall caps and clean any electrolyte spillage using a solution of baking soda and water.

**NOTE:** Hand tighten caps then tighten an additional 1/4 turn using a 20 mm (3/4 in) socket. Using other tool could damage the plastic battery caps.

#### **⚠ WARNING**

Battery electrolyte is caustic. To prevent spillage, battery cell cap should be sufficiently tight to properly seal.

### Charging a Used Battery

#### **⚠ WARNING**

Never charge battery while installed in watercraft.

For best results, battery should be charged when the electrolyte and the plates are at room temperature. A battery that is cold may not accept current for several hours after charging begun.

Do not charge a frozen battery. If the battery charge is very low, the battery may freeze. If it is suspected to be frozen, keep it in a heated area for about 2 hours before charging.

#### **⚠ WARNING**

Always charge battery in a well ventilated area.

The time required to charge a battery will vary depending on some factors such as:

- Battery temperature: The charging time is increased as the temperature goes down. The current accepted by a cold battery will remain low. As the battery warms up, it will accept a higher rate of charge.
- State of charge: Because the electrolyte is nearly pure water in a completely discharged battery, it cannot accept current as well as electrolyte. This is the reason the battery will not accept current when the charging cycle first begins. As the battery remains on the charger, the current from the charger causes the electrolytic acid content to rise which makes the electrolyte a better conductor and then, the battery will accept a higher charging rate.
- Type of charger: Battery chargers vary in the amount of voltage and current that they can supply. Therefore, the time required for the battery to begin accepting measurable current will also vary.

### Charging a Very Flat or Completely Discharged Battery

The battery charger should have an adjustable charging rate. Variable adjustment is preferred, but a unit which can be adjusted in small increments is acceptable.

The battery charger must be equipped with an ammeter capable of accurately measuring current of less than 1 ampere.

Unless this procedure is properly followed, a good battery may be needlessly replaced.

- Measure the voltage at the battery posts with an accurate voltmeter. If it is below 10 volts, the battery will accept current at very low rate, in term of milliamperes, because electrolyte is nearly pure water as explained above. It could be some time before the charging rate increases. Such low current flow may not be detectable on some charger ammeters and the battery will seem not to accept any charge.
- Exceptionally for this particular case, set the charger to a high rate.



## Section 06 ELECTRICAL SYSTEM

### Subsection 02 (CHARGING SYSTEM)

---

**NOTE:** Some chargers have a polarity protection feature which prevents charging unless the charger leads are connected to the correct battery terminals. A completely discharged battery may not have enough voltage to activate this circuitry, even though the leads are connected properly. This will make it appear that the battery will not accept a charge. Follow the charger manufacturer's instruction on how to bypass or override this circuitry so that the charger will turn on and charge a low-voltage battery.

- Since the battery chargers vary in the amount of voltage and current they provide, the time required for the battery to accept measurable charger current might be up to approximately 10 hours or more.
- If the charging current is not up to a measurable amount at the end of about 10 hours, the battery should be replaced.
- If the charging current is measurable before the end or at the end of about 10 hours, the battery is good and charging should be completed in the normal manner as specified in *ACTIVATION OF A NEW BATTERY*.
- It is recommended that any battery recharged by this procedure be load tested prior to returning it to service.

### Battery Installation

#### **WARNING**

Always connect battery cables exactly in the specified order, RED positive cable first BLACK negative cable last.

Proceed as follows:

- Install battery in its emplacement.
- Secure vent line to the battery and support. Ensure vent line is not kinked or obstructed.

#### **WARNING**

Vent line must be free and open. Avoid skin contact with electrolyte.

- First connect RED positive cable.
- Connect BLACK negative cable last.
- Apply dielectric grease on battery posts.
- Verify cable routing and attachment.

# STARTING SYSTEM

## SERVICE PRODUCTS

<b>Description</b>	<b>Part Number</b>	<b>Page</b>
dielectric grease .....	293 550 004 .....	242
Isoflex grease Topas NB52 .....	293 550 021 .....	242
Loctite 243 .....	290 897 651 .....	242



**Section 06 ELECTRICAL SYSTEM**  
Subsection 03 (STARTING SYSTEM)

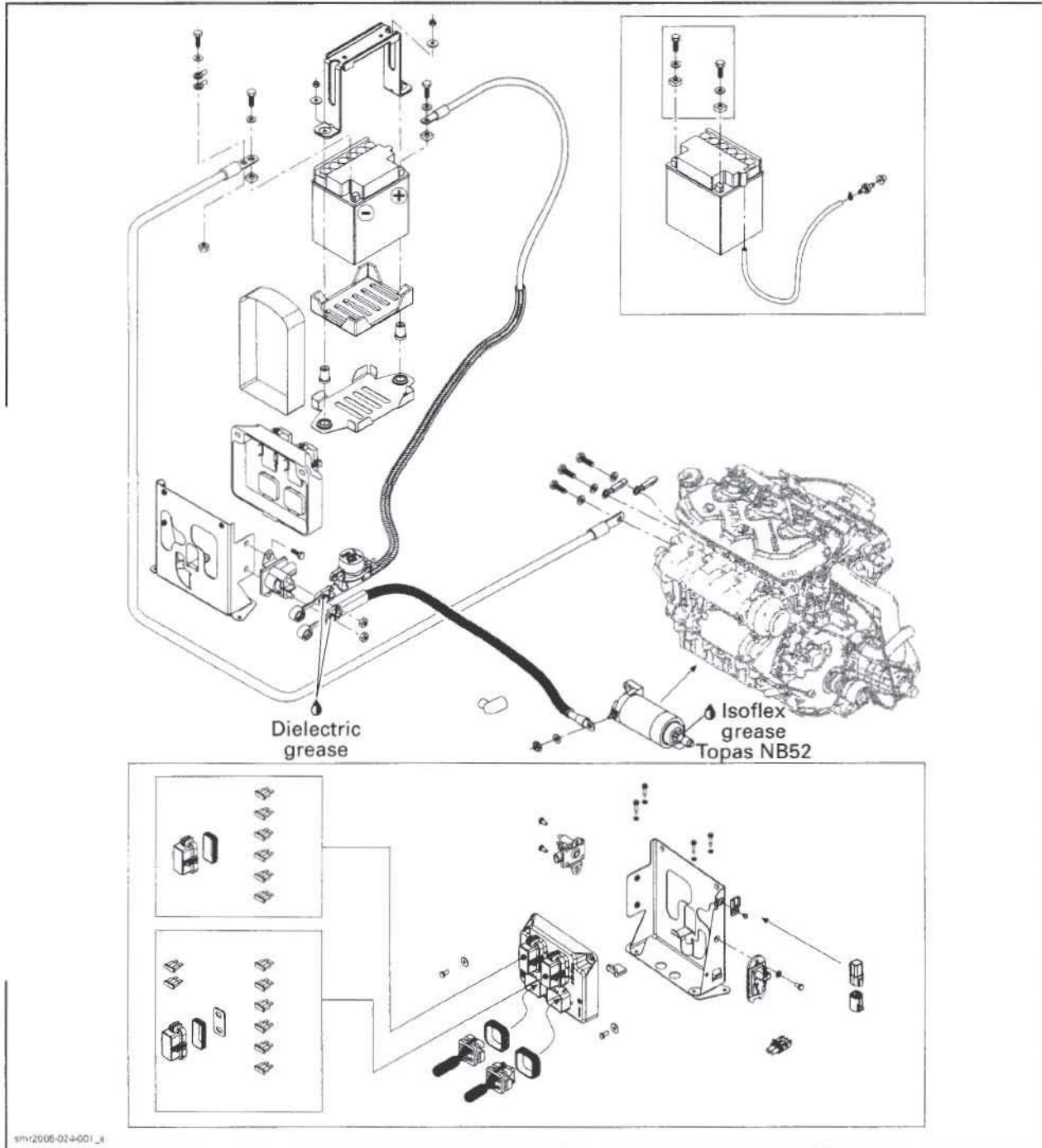





## Section 06 ELECTRICAL SYSTEM

### Subsection 03 (STARTING SYSTEM)

## GENERAL

Causes of troubles are not necessarily related to starter but may be due to a burnt fuse, faulty battery, start/stop switch, DESS post, MPEM or ECM, solenoid, electrical cables or connections. Check these components before removing starter.

To check battery condition, refer to *CHARGING SYSTEM*.

**NOTE:** It is a good practice to check for fault codes using B.U.D.S. software as a first troubleshooting step. Refer to *EMS DIAGNOSTIC AND COMMUNICATION TOOLS*.

Consult also the *TROUBLESHOOTING* section for a general view of possible problems.

### ⚠ WARNING

Short circuiting electric starter is always a danger, therefore disconnect the battery ground cable before carrying out any kind of maintenance on starting system. Do not place tools on battery.

## Starter Specifications

Nominal output	0.9 kW	
Voltage	12 V	
Rated time	30 seconds	
Rotation	Counterclockwise (viewed from pinion side)	
Weight	2.5 kg (5.39 lb)	
Performance specification at 20°C (68°F)	No load	11.4 V 23 A max. 8600 RPM
	Load	8.5 V 140 A max. 5200 RPM
	Stall	3.75 V 330 A max. 0 RPM

## TEST

### ELECTRICAL CABLES OR CONNECTIONS

Check all connections, cables and wires. Tighten any loose cables. Replace any chafed wires.

### FUSE

Make sure the 10 A fuse (no. 9 on wiring diagram) fuse on the MPEM and the 30 A main fuse (starting system) besides the MPEM are in good condition.

The solenoid may be the cause of a burnt fuse. If the solenoid checks good, one of the accessory may be defective.

### ENGINE CONTROL MODULE (ECM)

If 2 short beeps are not heard when installing the safety lanyard, refer to *ENGINE MANAGEMENT*.

### ENGINE START/STOP SWITCH

A quick operation test can be done with the B.U.D.S. software, using the **Monitoring** tab. Press the start button and look at the **Start button LED**. It should turn on, indicating the starting system is working on the input side of the starting system (start button, MPEM, ECM and wiring). You know now the problem is on the output side of the starting system (MPEM output signal to starting solenoid, wiring harness going to the solenoid and starter motor). Otherwise, check the input side as follows.

Disconnect the start/stop switch connector.

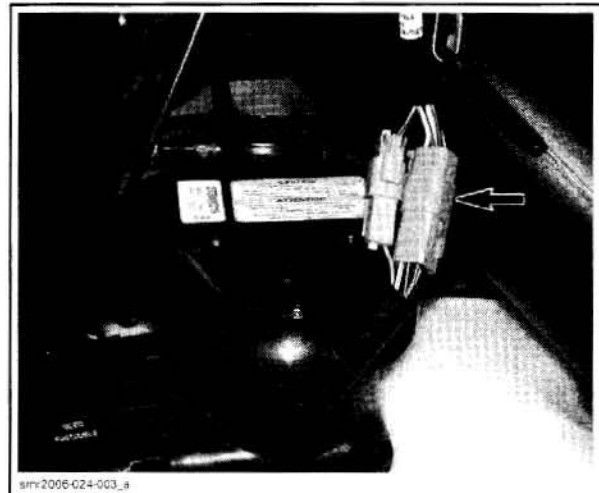

Use a multimeter and set it to  $\Omega$ . Measure resistance, as follows.

SWITCH POSITION	WIRES	RESISTANCE
Released	YELLOW/RED and PURPLE	Infinite (OL.)
Pressed and held		Up to 10 $\Omega$

**Section 06 ELECTRICAL SYSTEM**  
**Subsection 03 (STARTING SYSTEM)**

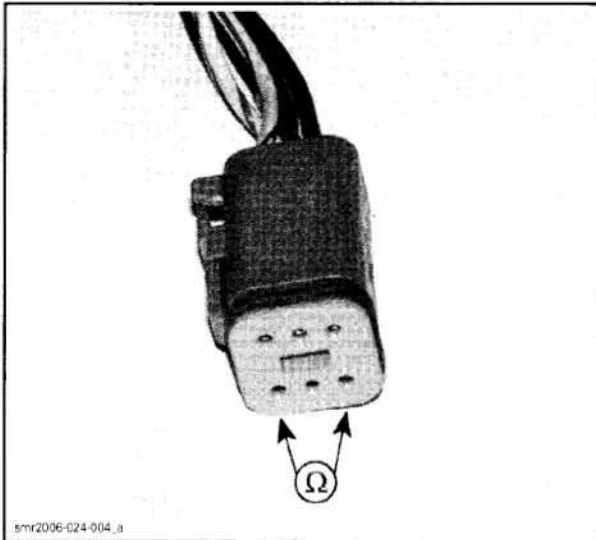

If switch is out of specification, replace it.  
 Test continuity of circuit 2-23. If it is faulty, repair harness/connectors. Otherwise, try a new MPEM.  
 Test continuity of circuit B-19. If it is faulty, repair harness/connectors. Otherwise, try a new ECM.

**SOLENOID**

Solenoid is located beside the MPEM.



Inspect connections and clean as necessary.

**Continuity Test**

Use a multimeter and set it to  $\Omega$ .  
 Measure winding resistance, as follows.

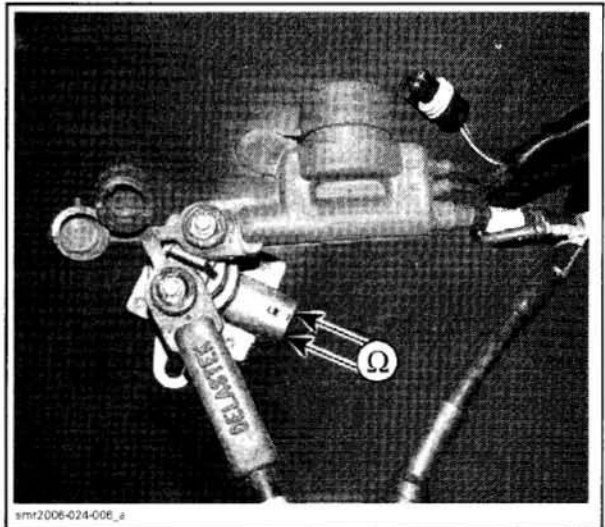

PIN	RESISTANCE
A and B	Approximately 5 $\Omega$

There should be no continuity between the positive posts of the solenoid.

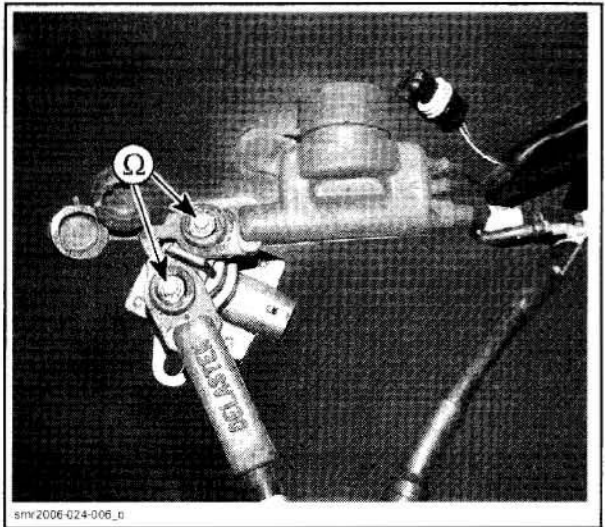

**Dynamic Test**

Set ECM in engine drowned mode as follows:  
 Depress throttle lever and install a rubber band to hold lever in full throttle position.  
 Use a multimeter and set it to Vdc.  
 Depress start/stop button and while engine is cranking, measure the voltage drop.



**Section 06 ELECTRICAL SYSTEM**  
**Subsection 03 (STARTING SYSTEM)**

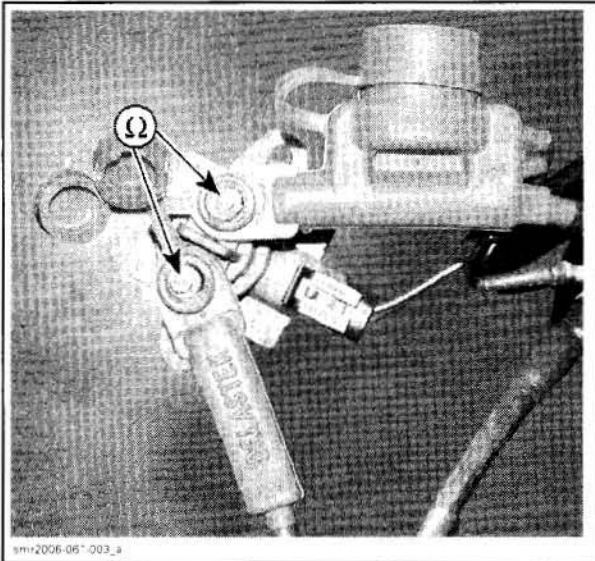

SOLENOID POST		VOLTAGE (DC)
Post coming from battery	Post going to starter	0.2 V max.

If voltage is out of specification, replace solenoid.

**⚠ WARNING**  
 Remove rubber band from throttle lever to release it.

**PARTS REPLACEMENT**

**STARTER**

**Removal**

Disconnect BLACK cable ground connection from battery.

**⚠ WARNING**  
 Always disconnect ground cable first and re-connect last.

Disconnect RED cable connection from battery.

**NOTE:** To facilitate starter removal on RXP models, remove engine cover. Refer to BODY section.

Remove retaining screws from starter.

Pull starter out. Lift starter enough to reach starter cable then disconnect from starter.

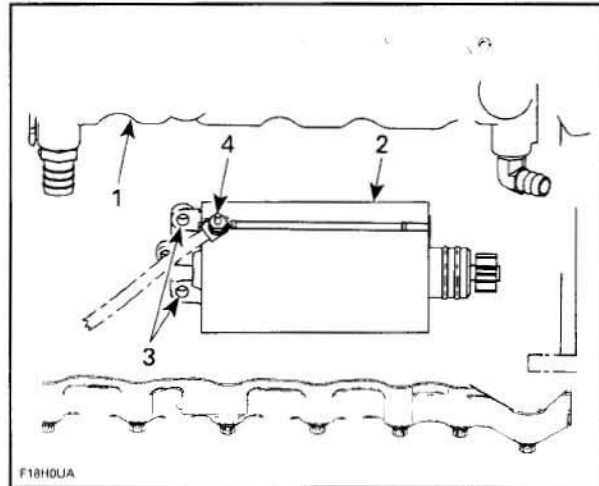

- 1. Exhaust manifold
- 2. Starter
- 3. Retaining screws
- 4. Nut

**Installation**

Installation is essentially the reverse of removal procedure. However, pay particular attention to the following.

Make sure that starter and engine mating surfaces are free of debris. Serious trouble may arise if starter is not properly aligned.

Apply grease Isoflex grease Topas NB52 (P/N 293 550 021) on O-rings of starter.

Install starter.

**NOTE:** If starter does not mesh properly, try to pull it out and slightly rotate the starter gear; then re-install starter. One could also temporarily remove both O-rings, properly mesh gears then remove starter to reinstall O-rings, being careful not to rotate gear to keep its position, to finally reinstall starter.

Apply Loctite 243 (P/N 290 897 651) on retaining screws and torque to 10 N•m (89 lbf•in).

Connect the RED positive cable to the starter and torque nut to 7 N•m (62 lbf•in). Apply dielectric grease (P/N 293 550 004) on terminal and nut.

Ensure to slide protector over nut to hide metallic parts.

**Section 06 ELECTRICAL SYSTEM**  
Subsection 03 (STARTING SYSTEM)

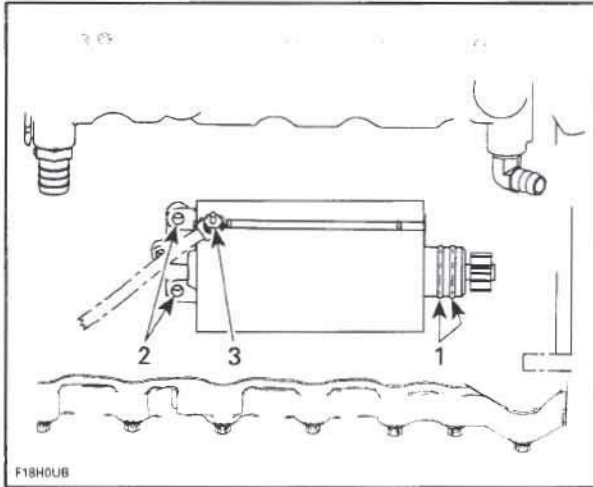

1. Dielectric grease on O-rings
2. Torque nut to 7 N•m (62 lb•in) and apply dielectric grease and install protection cover
3. 10 N•m (89 lb•in)

**⚠ WARNING**

Always connect RED positive cable first then BLACK negative cable last. Whenever connecting the RED positive cable to the starter motor make sure the battery cables are disconnected to prevent electric shock.

## STARTER GEAR

### Removal

Remove starter.

Remove gear retaining circlip and pull out starter gear.

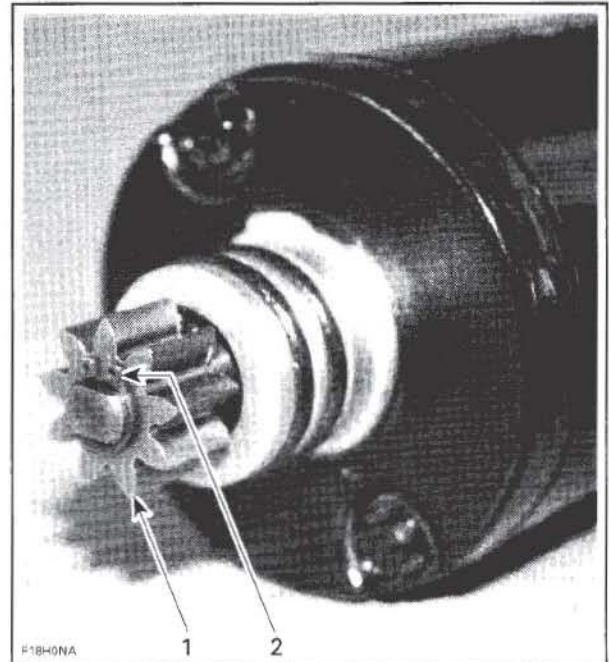

1. Retaining circlip
2. Starter gear

### Installation

Installation is essentially the reverse of removal procedure. However, pay particular attention to the following.

It is recommended to use a new circlip.



# DIGITALLY ENCODED SECURITY SYSTEM (DESS)

## SERVICE TOOLS

Description	Part Number	Page
multimeter FLUKE 111 .....	529 035 868 .....	247

## GENERAL

**NOTE:** It is a good practice to check for fault codes using B.U.D.S. software as a first troubleshooting step. Refer to *EMS DIAGNOSTIC AND COMMUNICATION TOOLS*.

This system allows starting the engine only with safety lanyard(s) that has been programmed to operate a specific watercraft. This functionality is the DESS system.

**NOTE:** If desired, a DESS key can be used on other watercraft equipped with the DESS. It only needs to be programmed for that watercraft.

The following components are specially designed for this system: Multi-Purpose Electronic Module (MPEM), ECM, DESS key and DESS post.

The DESS key cap contains a magnet and a ROM chip. The magnet actually closes the reed switch inside the post which is the equivalent of a mechanical ON/OFF switch. The chip has a unique digital code which is the equivalent of the notch pattern on a conventional key.

The system is quite flexible. Up to 8 keys may be programmed in the memory of the ECM. They can also be erased individually.

The memory of the ECM is programmed to recognize the digital code of the DESS key. This is achieved with the B.U.D.S. software.

In addition to the standard DESS key, the ECM also offers special keys that can be programmed so that the vehicle can be run only at a limited speed. Such feature is ideal for first time riders or renters.

AVAILABLE TYPE OF DESS KEYS	COLOR	MAXIMUM VEHICLE SPEED ALLOWED
Standard	Yellow	Full speed allowed
Learning	White	55 km/h (35 MPH)
Rental <sup>(1)</sup>	Orange	70 km/h (45 MPH)

**NOTE:** <sup>(1)</sup> Available on GTI Rental models only.

**⚠ WARNING**

When programming a Sea-Doo® Learning Key™ or Rental Key, use only a key that is identified for that purpose. Otherwise, a customer could use a vehicle with a greater speed than he was expecting.

When connecting a key on the post, the DESS is activated and will emit audible signals:

BEEP	SIGNIFICATION
2 short	Indicate a working DESS key. Engine starting can take place.
1 long	Indicates a wrong DESS key is being used or something is defective. Engine starting is not allowed.

Other beeps can be heard. The ECM features a self-diagnostic mode. Refer to *EMS DIAGNOSTIC AND COMMUNICATION TOOLS* for more information.

When ordering a new ECM from the regular parts channel, the DESS circuitry will be activated.

### Key Reminder

If engine is not started within 5 seconds after installing the DESS key on its post, 4 very short beeps every 3 second interval will sound to remind you to start the engine or to remove the key. Afterwards, the beeps will stop. The same will occur when the key is left on its post 5 seconds after engine is stopped.

## Section 06 ELECTRICAL SYSTEM

### Subsection 04 (DIGITALLY ENCODED SECURITY SYSTEM (DESS))

Always ensure DESS key is not left on its post after engine is stopped.

**IMPORTANT:** Leaving the DESS key on its post when engine is not running will slowly discharge the battery.

## KEY PROGRAMMING

Use the latest B.U.D.S. software available from BOSSWeb. Refer to *EMS DIAGNOSTIC AND COMMUNICATION TOOLS* for proper connection instructions.

The B.U.D.S. software is designed to allow, among other things, the programming of DESS key(s) and entering customer information.

For more information pertaining to the use of the software B.U.D.S., use its help which contains detailed information on its functions.

### WARNING

If the computer you are using is connected to the 110 Vac power outlet, there is a potential risk of electrocution when working in contact with water. Be careful not to touch water while working with the VCK.

Read ECM using READ DATA button.

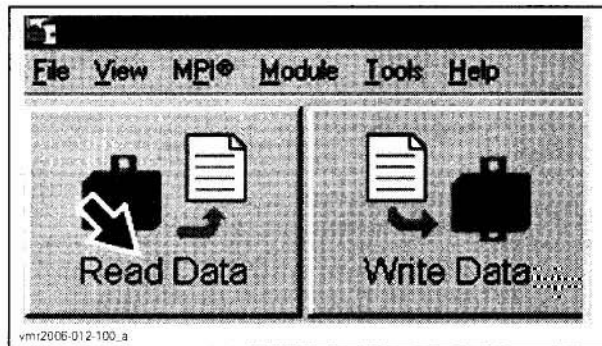

Install the new key to be programmed on MPI or DESS post interface tool.



MPI

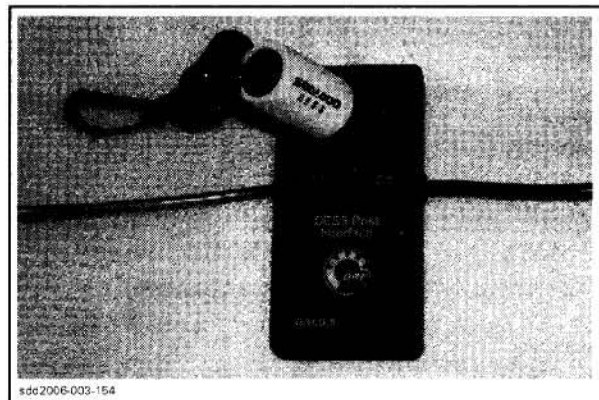

MPI-2

Click on KEYS tab.

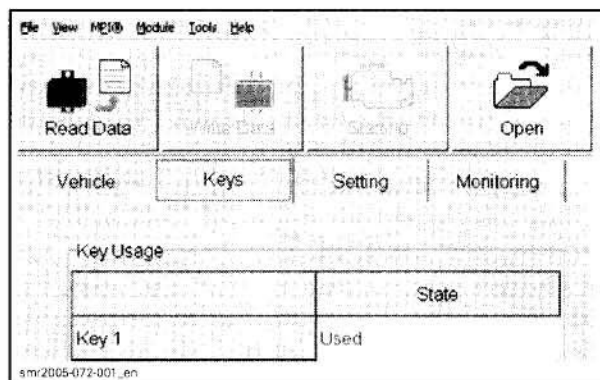

Click on the desired ADD KEY button on bottom of screen according to the type of key you want to program. Ensure to use the color that matches the key usage.

A new key is now saved in the computer.

**NOTE:** To program other key(s), install a new key and click again on ADD KEY tab.

Ensure to save new data in ECM using WRITE DATA button.



**Section 06 ELECTRICAL SYSTEM**  
Subsection 04 (DIGITALLY ENCODED SECURITY SYSTEM (DESS))

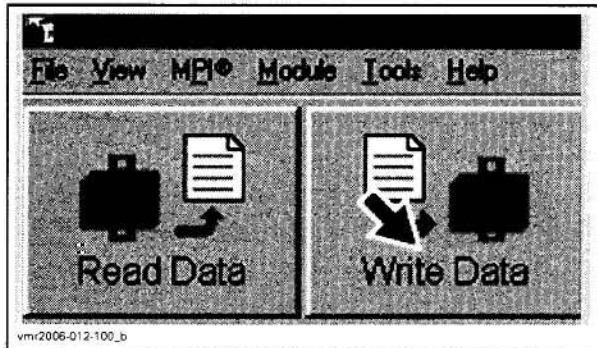

## TROUBLESHOOTING

If no beep is heard when installing the DESS key on the post, test beeper operation as follows.

Use the latest B.U.D.S. software available from BOSSWeb. Refer to *EMS DIAGNOSTIC AND COMMUNICATION TOOLS* for proper connection instructions.

Energize Buzzer from Activation tab.

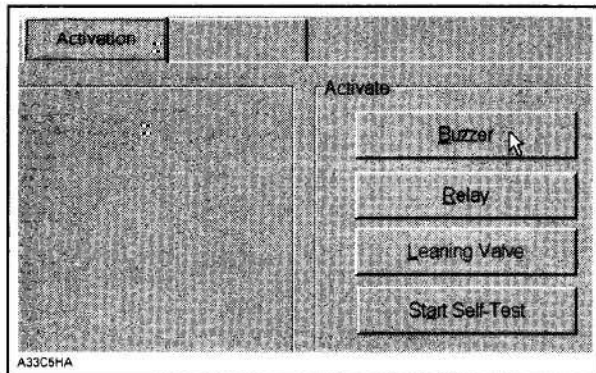

If beeper properly works, refer to *EMS DIAGNOSTIC AND COMMUNICATION TOOLS* and check for fault codes. If beeper does not work, check it and its wiring.

### DESS Post

The following continuity tests can be performed using an ohmmeter.

For best results, use the multimeter FLUKE 111 (P/N 529 035 868).

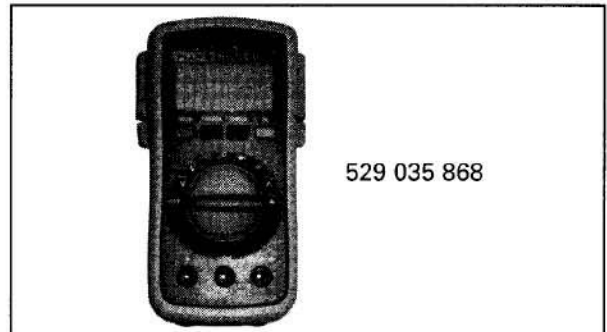

Disconnect DESS post wires.

### DESS Key Removed from Post

Connect test probes to DESS post as per tables and measure resistance.

DESS POST		RESISTANCE $\Omega$ @ 20°C (68°F)
WIRE		
BLACK	BLACK/YELLOW	Open circuit

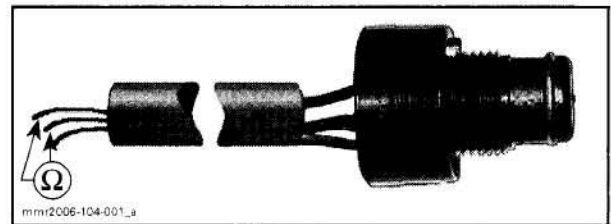

DESS POST		RESISTANCE $\Omega$ @ 20°C (68°F)
WIRE		
WHITE/GREY	Post terminal	Close to 0 $\Omega$

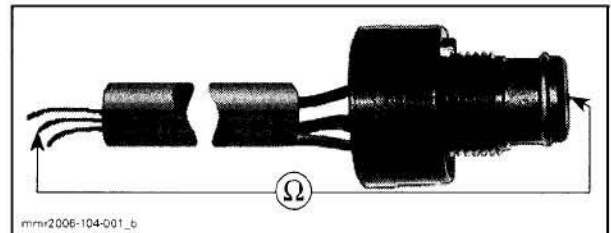

DESS POST		RESISTANCE $\Omega$ @ 20°C (68°F)
WIRE		
BLACK	Post ring	Close to 0 $\Omega$

## Section 06 ELECTRICAL SYSTEM

### Subsection 04 (DIGITALLY ENCODED SECURITY SYSTEM (DESS))

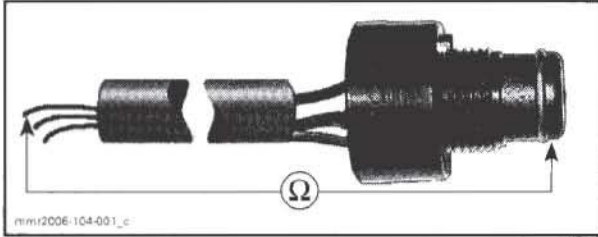

#### DESS Key on Post

Connect test probes to DESS post as per table and measure resistance.

DESS POST		RESISTANCE $\Omega$ @ 20°C (68°F)
WIRE		
BLACK	BLACK/YELLOW	Close to 0 $\Omega$

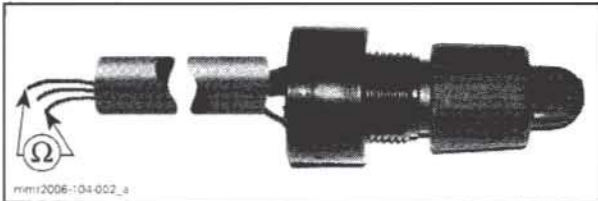

If any resistance test fails, replace DESS post.



# GAUGE, SENSORS AND FUSES

## SERVICE TOOLS

Description	Part Number	Page
multimeter Fluke 111 .....	529 035 868 .....	249

### GENERAL

**NOTE:** For a complete overview of the vehicle electrical system, refer to *ENGINE MANAGEMENT*.

**NOTE:** It is a good practice to check for fault codes using B.U.D.S. software as a first troubleshooting step. Refer to *EMS DIAGNOSTIC AND COMMUNICATION TOOLS*.

**⚠ WARNING**

It is recommended to always disconnect the battery when replacing any electric or electronic parts. Always disconnect battery exactly in the specified order, BLACK (-) cable first. Do not place tools on battery. Clean threads before applying a threadlocker. Refer to *SELF-LOCKING FASTENERS* and *LOCTITE APPLICATION* at the beginning of this manual for complete procedure. Torque wrench tightening specifications must strictly be adhered to. Locking devices (e.g.: locking tabs, elastic stop nuts, self-locking fasteners, etc.) must be installed or replaced with new ones where specified. If the efficiency of a locking device is impaired, it must be renewed.

It is possible that a component seems to operate in static condition but in fact, it is defective. In this case, the best way to solve this problem is to remove the original part and replace it with a known good component.

**IMPORTANT:** When solving an electrical problem, the first thing to do is to check battery condition as well as its cables and connections. Install safety lanyard to activate ECM, MPEM and Information Center to perform testing procedures that requires the device to be supplied with electricity. Check solidity (close to battery) and related-circuit fuse condition with an ohmmeter (visual inspection could lead to false results). Also visually examine harness and connections.

For best results, use the multimeter Fluke 111 (P/N 529 035 868).



Pay particular attention to ensure that pins are not out of their connectors or damaged. The troubleshooting procedures cover problems not resulting from one of these causes.

**CAUTION:** Ensure all terminals are properly crimped on wires and connector housings are properly fastened. replacing any electric or electronic part(s), always check electrical connections. Make sure that they are tight and they make good contact and are corrosion-free. The voltage and current might be too weak to go through dirty wire pins. Check the posts for signs of moisture, corrosion or if they look dull. Clean pins properly and then coat them with silicon-based dielectric grease or other appropriate lubricant (except if otherwise specified) when reassembling them. See connectors information in *ELECTRICAL CONNECTORS*.

Pay attention to ground wires.

### Checking for Shorts Between 2 Wires

When checking continuity of a wire in a circuit, wires should be checked for short circuit as follows.

Make sure to isolate circuit by unplugging connectors.

Let's suppose that the circuit to be checked has a RED and a BLACK wire. Using an ohmmeter, measure the resistance between the RED and the BLACK wire. The resistance should be infinite (OL). Otherwise, there is a short circuit between both wires. We must therefore identify and correct the fault.

**Section 06 ELECTRICAL SYSTEM**  
**Subsection 05 (GAUGE, SENSORS AND FUSES)**

**Addition of Electrical Accessories**

Every time an electrical accessory is added such as an electric bilge pump or a VTS for instance, it must be registered using B.U.D.S. to activate it in the MPEM.

If an option is installed but not checked in B.U.D.S., the information center will not display that option. If an option is checked in B.U.D.S. but not installed in vehicle, SENSOR will be displayed in Information Center.

Use the OPTIONS area in the **Setting** tab in B.U.D.S.

**FUSES**

If an electrical problem occurs, check the fuses. If a fuse is burnt, replace by one of the same rating.

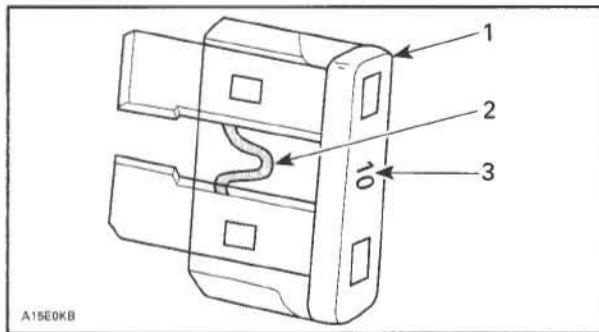

- 1. Fuse
- 2. Check if melted
- 3. Ampere rating

**⚠ WARNING**  
 Do not use a higher rated fuse as this can cause severe damage. If a fuse has burnt out, source of malfunction should be determined and corrected before restarting.

Fuses can be found on the MPEM and on starting solenoid cable besides MPEM.

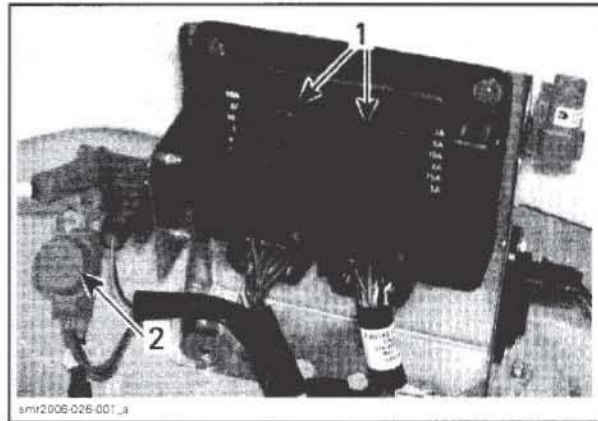

TYPICAL  
 1. MPEM fuses  
 2. Main fuses

**MPEM Fuses Identification**

Fuses rating are identified on the MPEM, beside the fuse holders.

MPEM	
Camshaft position sensor	10 A
Spare fuse (accessory).	2 A
Depth sounder (GTX LTD)	10 A
Cylinder 3 ignition coil and injection	10 A
Spare fuse (permanent 12V)	1 A
Cylinder 2 ignition coil and injection	10 A
Cylinder 1 ignition coil and injection	10 A
	3 A Bilge pump (optional), beeper, diagnostic connector
	5 A Information center, TOPS sensor
	10 A Electric starter, fuel pump
	2 A MPEM
	7.5 A VTS (if so equipped)
	5 A EMS, start/stop switch



**Section 06 ELECTRICAL SYSTEM**  
 Subsection 05 (GAUGE, SENSORS AND FUSES)

**Main Fuses Identification**

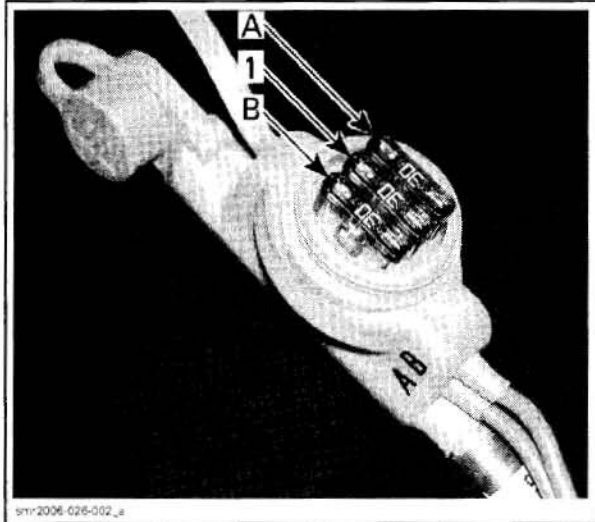

- 1. Spare fuse
- A. Main fuse
- B. Charging system fuse

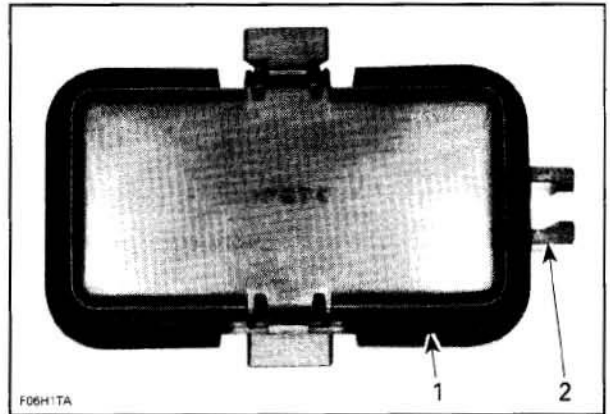

- 1. Fuse cover
- 2. Fuse tabs

One cover contains spare fuses.

To gain access to spare fuses, remove the cover identified "SPARE FUSES INSIDE". Look inside cover and pull the rubber protector with a finger. Take care not to drop the fuses.

**MPEM Fuse Replacement**

Squeeze locking tabs together, hold and pull fuse cover from the MPEM.

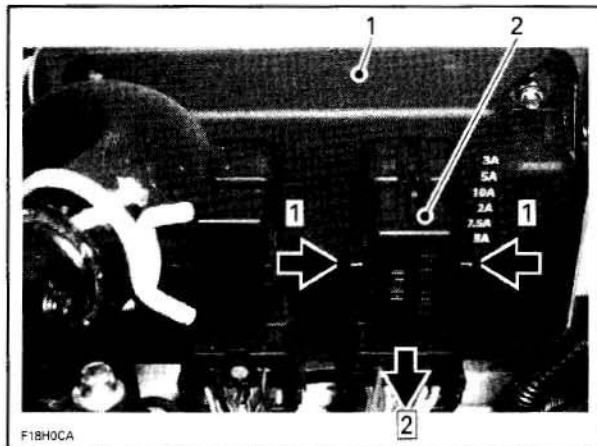

- TYPICAL**  
 Step 1: Press  
 Step 2: Pull  
 1. MPEM  
 2. Fuse cover

Use the tabs of the fuse cover to remove and re-install fuses. Slide cover tabs along fuse top.

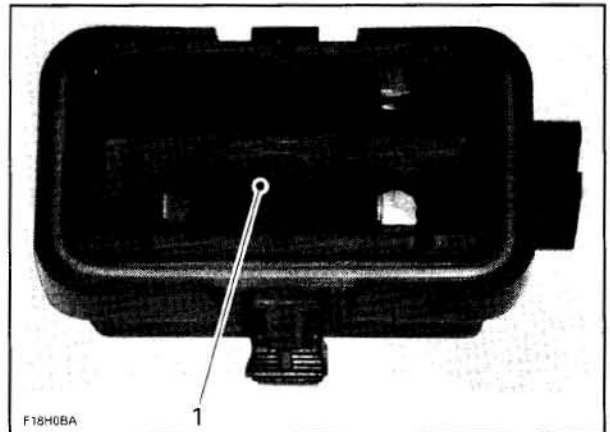

- 1. Rubber protector

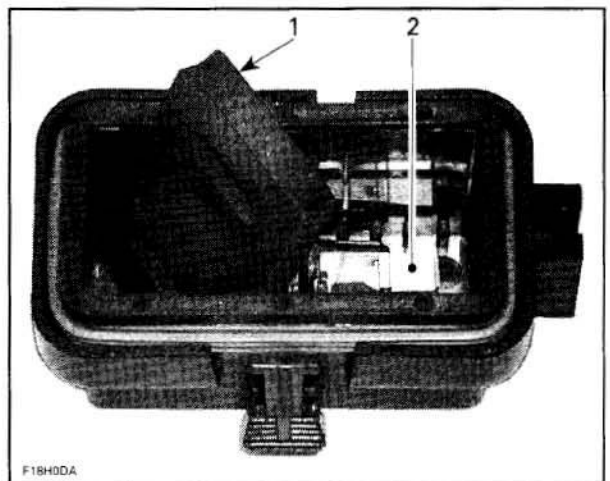

- 1. Rubber protector
- 2. Spare fuses

**Section 06 ELECTRICAL SYSTEM**  
**Subsection 05 (GAUGE, SENSORS AND FUSES)**

When finished, reinstall the remaining fuse(s) and reinstall the protector over fuse(s).

**CAUTION:** Do not install more than 4 fuses in cover to allow proper installation of cover.

**INFORMATION CENTER**

**Overview**

This is a multifunction gauge that supplies several real time useful information to the driver either in English, French or Spanish. Units can be displayed either in SAE custom system or in the metric system. Use B.U.D.S. to change these functions.

At start-up, all LCD segments and indicator lights will turn on for 3 seconds each time the information center is activated (when safety lanyard is installed). This allows the driver to validate they are all working properly.

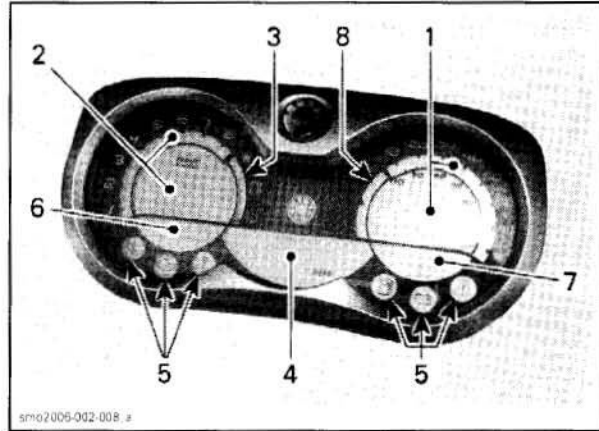

- OTHER MODELS**
- 1. Speedometer
  - 2. Tachometer
  - 3. Fuel level
  - 4. Information display
  - 5. Indicator lights
  - 6. Water depth display
  - 7. Water temperature display
  - 8. VTS position indicator

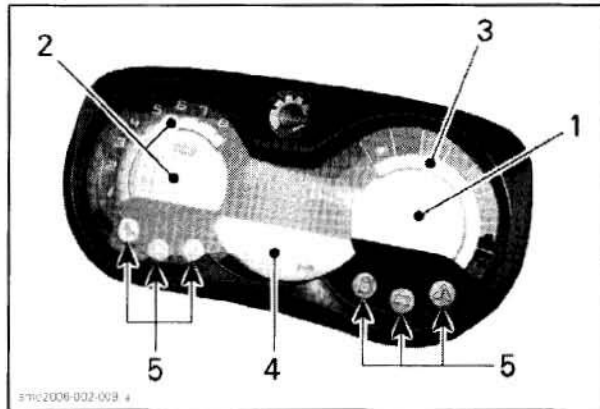

- GTI MODELS**
- 1. Speedometer
  - 2. Tachometer
  - 3. Fuel level
  - 4. Information display
  - 5. Indicator lights

**1) Speedometer**

Speedometer indicates the speed of watercraft in miles per hour (MPH) or kilometers per hour (km/h).

**2) Tachometer**

Tachometer indicates the revolutions per minute (RPM) of the engine. Multiply by 1000 to obtain the actual revolutions.

**3) Fuel Level**

Bar gauge continuously indicates the amount of fuel in the fuel tank while riding. A low-fuel condition is also indicated on the information display as only one bar is displayed. See MESSAGE DISPLAY below.

**4) Information Display**

**On so Equipped Models**

**Compass**

Displays the cardinal points to indicate the orientation of the watercraft.

**⚠ WARNING**

Use the compass as a guide only. Not to be used for navigation purposes.

**Water Temperature**

Displays the water temperature of the water surface in degrees Celsius (°C) or Fahrenheit (°F).

**NOTE:** Water temperature and depth gauge will be displayed alternately.



---

## Section 06 ELECTRICAL SYSTEM

### Subsection 05 (GAUGE, SENSORS AND FUSES)

---

#### Water Depth

Display the water depth under the hull within 0 to 50 meters (0 to 170 feet).

**NOTE:** Under certain conditions, the gauge may stop displaying. The gauge ability to display the depth depends on the usage conditions.

#### **WARNING**

Never use the depth gauge as a warning device to ride in shallow water. Use it as a navigation guide only. Not to be used for navigation purposes.

**NOTE:** Water temperature and depth gauge will be displayed alternately.

#### **All Models**

##### Hourmeter (HR)

Displays the time in hours of the watercraft usage.

##### Message Display

Displays a message whenever one of the following circumstances occurs. The abbreviations between parenthesis here are the code displayed:

- engine or exhaust system overheating (EX-HAUST or ENGINE)
- low oil pressure (OIL)
- low battery voltage (12 V LOW)
- high battery voltage (12 V HI)
- low fuel level (FUEL-LO)
- maintenance reminder (MAINT)

**NOTE:** When the watercraft is due for a maintenance inspection, the message MAINT will blink. After servicing, clear it using B.U.D.S.

- check engine (CHK ENG)

**NOTE:** If a fault occurs, this system generates numbered fault codes (P-XXXX) that are displayed through the information center. Use B.U.D.S. to help troubleshooting.

- sensor failure (vehicle electronic equipment) (SENSOR)
- invalid safety lanyard (KEY)
- safety lanyard, learning key active (L KEY) (includes the Rental key as well).

A beeper will sound and indicator light will blink depending on the fault occurring to catch the driver attention when necessary. Use B.U.D.S. for troubleshooting when such a message is displayed.

#### 5) Indicator Lights

**NOTE:** Refer to *INFORMATION DISPLAY* above for additional information regarding messages.

##### Low oil pressure (OIL)



Check engine (CHK ENG)



Engine or exhaust system overheating (H-TEMP)



Low fuel level (FUEL-LOW)



Low/high battery voltage (12 V LOW/HI)



Maintenance reminder (MAINT)



#### 6) Water Depth Display

##### **On so Equipped Models**

Displays the water depth under the hull within 0 to 50 meters (0 to 170 feet).

**NOTE:** Under certain conditions, the gauge may stop displaying. The gauge ability to display the depth depends on the usage conditions.

#### **WARNING**

Never use the depth gauge as a warning device to ride in shallow water. Use it as a navigation guide only. Not to be used for navigation purposes.

**7) Water Temperature Display**

**On So Equipped Models**

Displays the water temperature of the water surface in degrees Celsius (°C) or Fahrenheit (°F).

**8) VTS Position Indicator**

**On So Equipped Models**

The VTS position indicator shows the riding attitude of the watercraft.

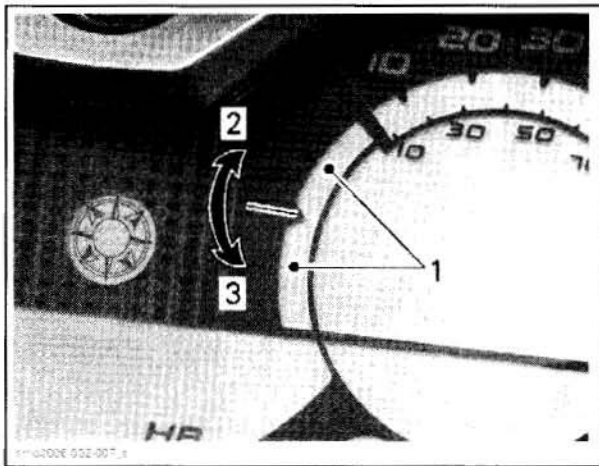

1. Position indicator  
 2. Bow up  
 3. Bow down

- Check communication link wires (WHITE/RED and WHITE/BLACK):
  - To quickly check if the communication link is working, temporarily disconnect a sensor on the engine to create a fault code. Start the engine. The information center should display a fault code.
  - Check if wires are swapped, unconnected or short circuited.
  - One faulty wire will cause a longer delay to perform the self-test when safety lanyard is installed.
- If everything tests good, try a new information center.

**Information Center Removal**

**CAUTION:** Information center locking tabs may break when removing its trim; extreme care must be taken while performing trim removal procedure.

Take a small wooden stick (coffee stirrer type) and chamfer its end; refer to photo.

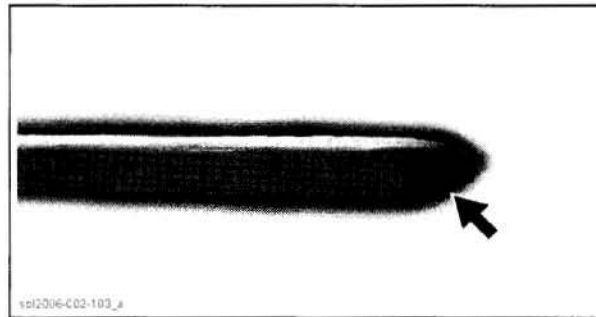

Slide chamfered end between trim and information center, in line with each side locking tab, pushing out smoothly while lifting out trim; repeat procedure with lower locking tab and then, gently lift trim upward, out of its upper locking tabs.

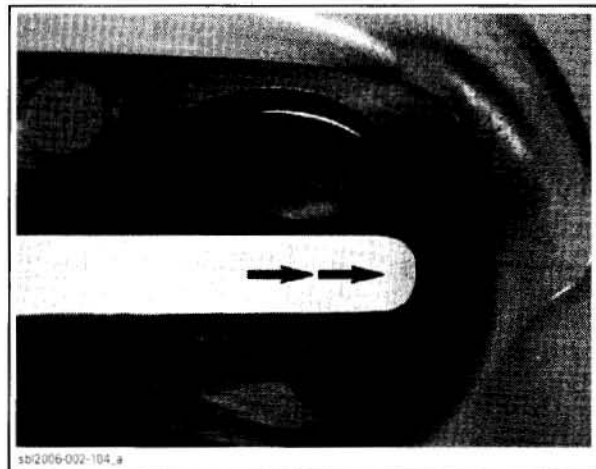

**PROCEDURES**

**INFORMATION CENTER**

**Setting Language and Units**

Use B.U.D.S. and go to page 2 in **Settings** tab.

**Clearing Maintenance Light**

Use B.U.D.S. and use Reset button in **Vehicle** tab.

**Troubleshooting**

When there is no display at the information center, perform the following:

- Check fuses.
- B.U.D.S. can be used to check its operation. Look in the **Monitoring** tab.
- Check supply wire (1-18) and ground wire (1-8) from MPEM.



## Section 06 ELECTRICAL SYSTEM

### Subsection 05 (GAUGE, SENSORS AND FUSES)

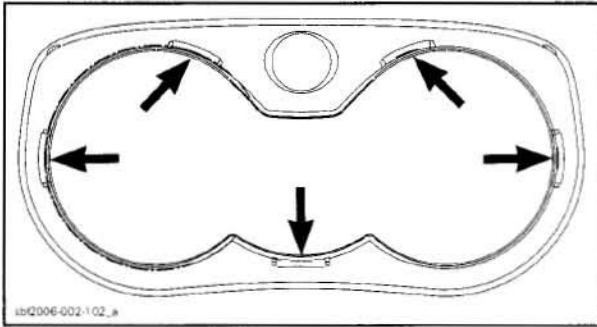

Remove and keep both screws retaining information center.



1. Information center screws

Unplug and set information center aside.

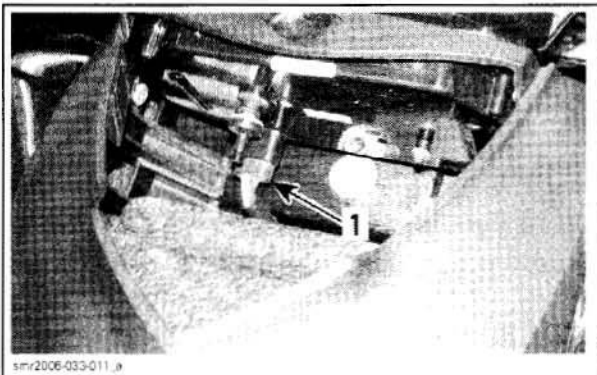

1. Information center connector.

**NOTE:** At 2 places at the bottom of information center, rubber pads are folded on body for a tight fit; care should be taken not to lose those pads so they are reused when reinstalling information center.

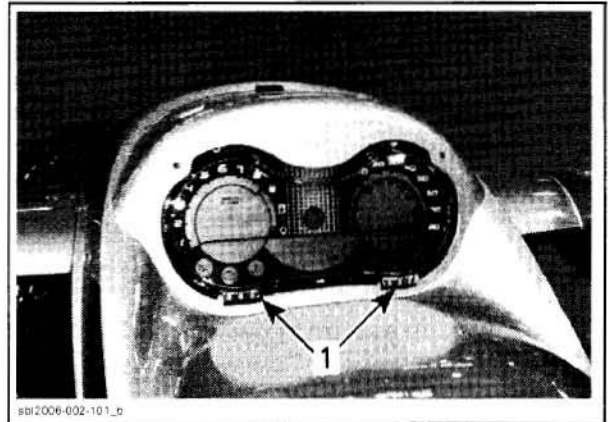

1. Rubber pads

### Information Center Installation

The installation is the reverse of the removal procedure. However, pay attention to the following. Torque screws to a **MAXIMUM** of 1.5 N•m (13 lbf•in).

Reinstall information center trim simply by pushing it in so it snaps back in place.

### New Information Center Settings

Use B.U.D.S. to set parameters in information center.

Install safety lanyard on its post.

**NOTE:** If an information center from another watercraft model is installed, the following message will be displayed. Also, engine starting will not be allowed.

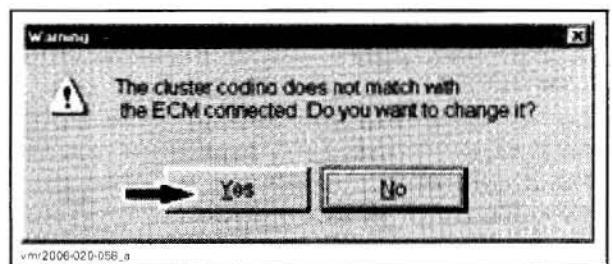

Click NO and install the appropriate information center for this watercraft.

**NOTE:** If for some reason, you need to start engine, click YES. Engine starting will be allowed and the message will not appear anymore. Remove and reinstall safety lanyard to start engine. However, since this is not the right gauge, some functions may not work properly.

Set language and units as described above.

Set compass pitch (if so equipped) in page 2 of Settings tab as per following table.

## Section 06 ELECTRICAL SYSTEM

### Subsection 05 (GAUGE, SENSORS AND FUSES)

MODELS	COMPASS PITCH
GTX and RXT	41
RXP	51

**NOTE:** Failure to properly set compass pitch will lead to inaccurate display of compass.

### FUEL BAFFLE PICK-UP SENDER

The fuel pick-up system is part of the fuel pump module mounted inside the fuel reservoir.

The fuel level gauge sender is also mounted on this module.

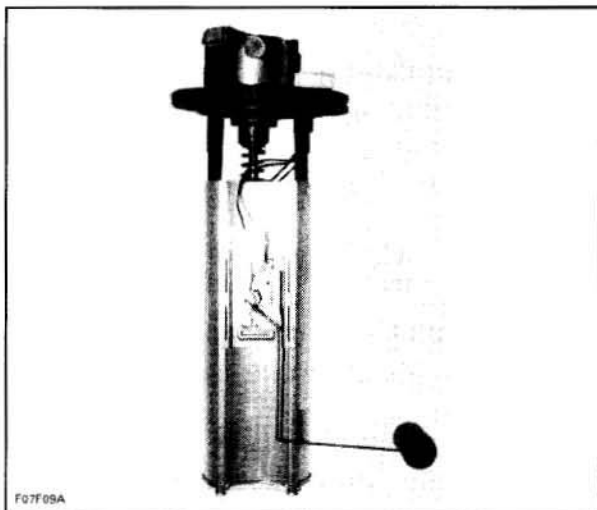

TYPICAL — FUEL LEVEL GAUGE SENDER MOUNTED ON FUEL PUMP MODULE

Refer to *FUEL TANK AND FUEL PUMP* for fuel pump testing. For fuel level sensor, follow procedures below.

The resistance measured between PINK/BLACK and PINK wires must be in accordance with fuel level (measured from under the flange) as specified in the following charts.

RESISTANCE ( $\Omega$ )	FLOAT HEIGHT (bottom of float with bottom of pump module) (mm)
$4.8 \pm 2.2$	$247 \pm 5.0$
$17.8 \pm 2.2$	$207 \pm 5.0$
$27.8 \pm 2.2$	$183 \pm 5.0$
$37.8 \pm 2.2$	$158 \pm 5.0$
$47.8 \pm 2.2$	$133 \pm 5.0$
$57.8 \pm 2.4$	$105 \pm 5.0$
$67.8 \pm 2.8$	$76 \pm 5.0$
$77.8 \pm 3.6$	$55 \pm 5.0$
$89.8 \pm 3.6$	$35.3 \pm 5.0$

### WATER TEMPERATURE SENSOR

#### *On so Equipped Models*

The water temperature sensor is integrated with the speed. As a result, that sensor has 3 wires instead of 2.

B.U.D.S. can be used to check its operation. Look in the **Monitoring** tab.

To check if the water temperature sensor is operational, select the water temperature mode in the Information Center.

With a garden hose, spray the speed sensor with water. The temperature reading on the Information Center should adjust to the water temperature.

If not, replace the speed sensor.

### COMPASS

#### *On so Equipped Models*

The compass is located inside the information center.

B.U.D.S. can be used to check the operation. Look in the **Monitoring** tab.

Change the direction of the vehicle. There should be a change of direction on the Information Center.

**NOTE:** To check the accuracy of the compass, you can use a portable compass and point it in the same direction. Compare the given directions, they should be the same otherwise, check compass pitch setting with B.U.D.S. If the setting is appropriate, try a new information center.



## SPEED SENSOR

The speedometer gives a reading through a speed sensor. It works with the water flow which turns a magnetic paddle wheel that triggers an electronic pick-up that in turn sends a speed signal to the speedometer through the MPEM.

The paddle wheel is protected by the pick-up housing.

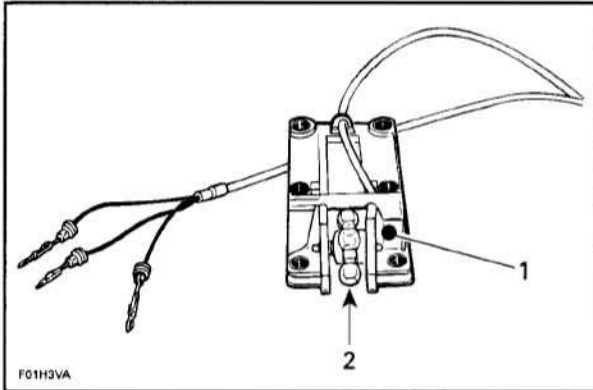

1. Pick-up housing
2. Paddle wheel

To check if the speed sensor is operational, disconnect the speed sensor connector housing from inside bilge.

Using an appropriate terminal remover (Snap-on TT600-4), remove the PURPLE/YELLOW and BLACK/ORANGE wires from the tab housing of the speed sensor.

**NOTE:** On models with 3 wires, the remaining wire is for the water temperature sensor.

Reconnect the PURPLE/YELLOW and BLACK/ORANGE wires in the receptacle housing.

Connect the positive probe of a multimeter to speed sensor PURPLE/YELLOW wire and the negative probe to speed sensor BLACK/ORANGE wire.

Slowly rotate the paddle wheel. Every 1/8 turn, the observed voltage should fluctuate between 5.5 and 8.5 Vdc.

## DEPTH GAUGE

### *On so Equipped Models*

#### Removal

Remove muffler.

Turn depth gauge counterclockwise and pull it out.

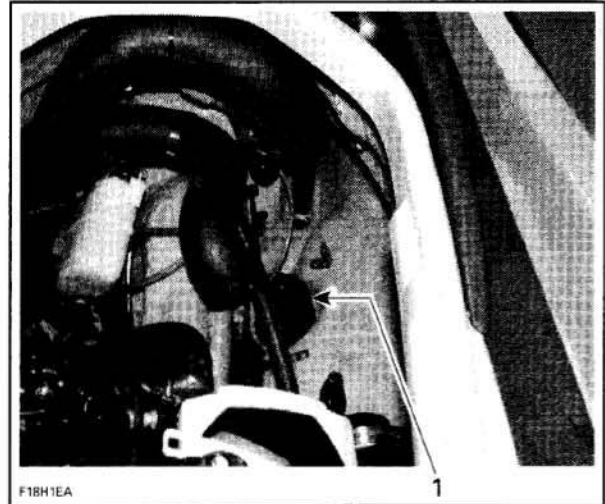

**TYPICAL**  
1. Depth gauge

#### Inspection

Ensure the silicone pad is in good condition. There must be no air between the bottom of the depth gauge and the bilge. Otherwise, the gauge will not work.

If silicone pad is damaged, replace it.

#### Installation

Ensure O-ring is in good condition and in place.

After installation, try pulling the gauge out to ensure it is properly locked.

Test run gauge.

# JET PUMP

## SERVICE TOOLS

<b>Description</b>	<b>Part Number</b>	<b>Page</b>
drive shaft holder.....	529 035 986 .....	265
Impeller remover/installer.....	529 035 820 .....	268-269
Impeller remover/installer.....	529 035 956 .....	268-269
impeller shaft pusher.....	529 035 955 .....	269, 271-272
pressure cap.....	529 035 843 .....	263
seal/bearing pusher .....	529 035 819 .....	271-273
vacuum/pressure pump kit.....	529 031 800 .....	263

## SERVICE PRODUCTS

<b>Description</b>	<b>Part Number</b>	<b>Page</b>
jet pump bearing grease.....	293 550 032 .....	272-273
Loctite 243 (blue).....	293 800 060 .....	264, 266
Loctite 767 (antiseize lubricant).....	293 800 070 .....	269
pulley flange cleaner.....	413 711 809 .....	265, 269
XP-S Lube.....	293 600 016 .....	266, 269
XP-S synthetic grease.....	293 550 010 .....	266, 269



# Section 07 PROPULSION

## Subsection 01 (JET PUMP)

### PLASTIC HOUSING

GTI Series (except GTI Rental), GTX and GTX WAKE Models

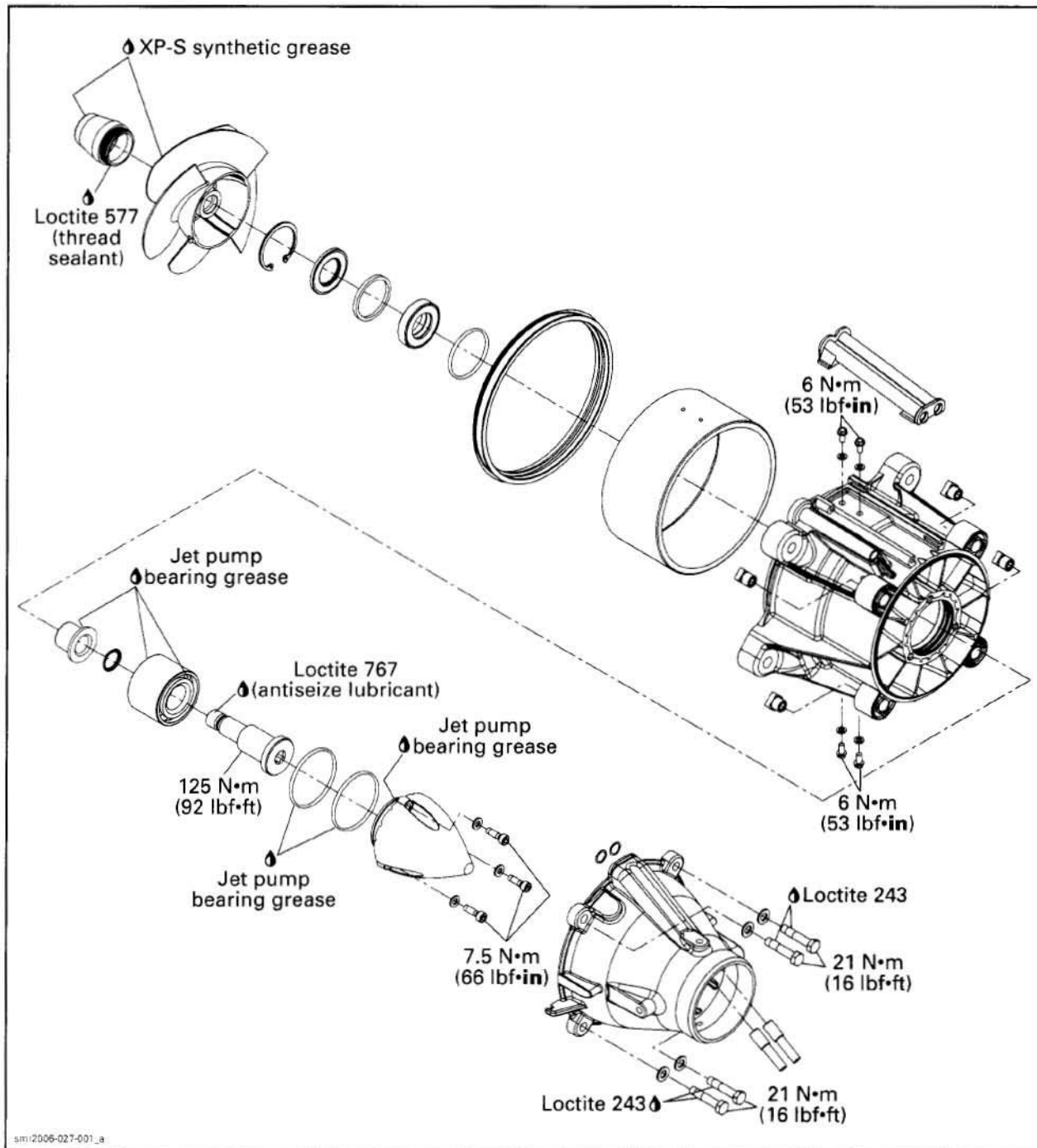

**ALUMINUM HOUSING**

*GTIRental, GTX Limited, GTX Supercharged, RXP and RXT Models*

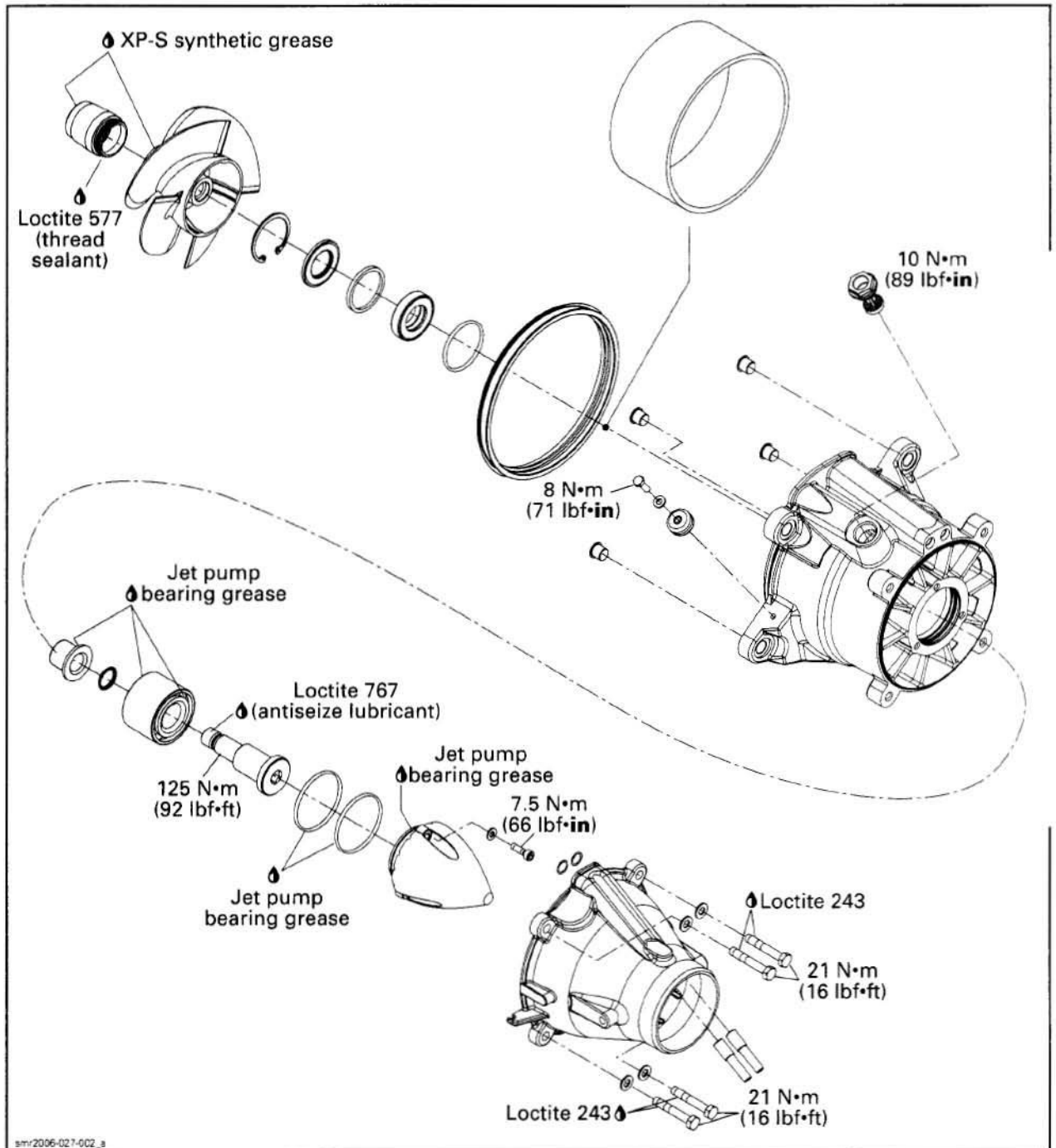



## Section 07 PROPULSION

### Subsection 01 (JET PUMP)

## GENERAL

During assembly/installation, use torque values and service products as in the exploded views.

Clean threads before applying a threadlocker. Refer to *SELF-LOCKING FASTENER* and *LOCTITE APPLICATION* at the beginning of this manual for complete procedure.

### **⚠ WARNING**

Torque wrench tightening specifications must strictly be adhered to.

Locking devices (e.g.: locking tabs, elastic stop nuts, self-locking fasteners, cotter pins, etc.) must be installed or replaced with new ones when specified. If the efficiency of a locking device is impaired, it must be renewed.

## Jet Pump Main Components

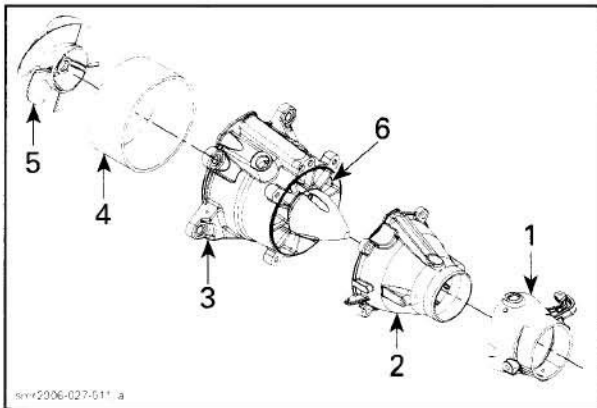

### TYPICAL

1. Nozzle
2. Venturi
3. Jet pump housing
4. Wear ring
5. Impeller
6. Stator

## INSPECTION

### IMPELLER CONDITION

Condition of impeller, impeller boot and impeller ring can be quickly checked from underneath of the watercraft. With the vehicle on the trailer, use a flashlight and look through the inlet grate.

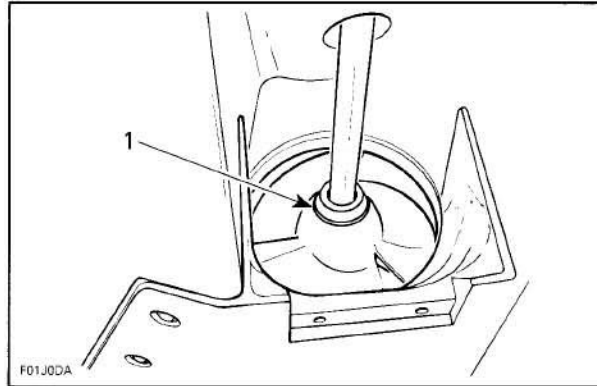

### TYPICAL

1. Inspect impeller and boot

## IMPELLER/WEAR RING CLEARANCE

This clearance is critical for jet pump performance.

To check clearance, remove jet pump.

Using a feeler gauge, measure clearance between impeller blade tip and wear ring. Measure each blade at its center.

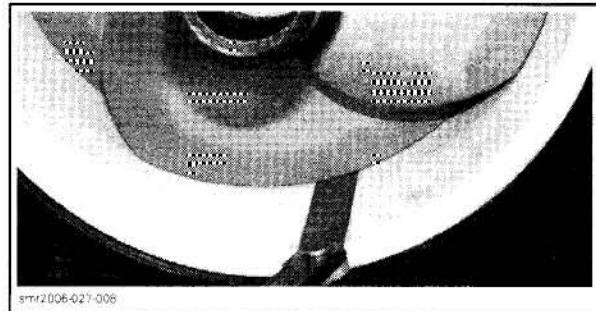

MODEL	MAXIMUM WEAR CLEARANCE mm (in)
All 4-TEC except GTI rental models	0.35 (.014)
GTI rental	0.76 (.030)

**NOTE:** The inner diameter of the wear ring on Rental GTI's aluminum pump is larger than the other models. The minimum clearance between impeller and wear ring is 0.51 mm (.020 in). This wear ring is BLACK and do not replace it with another type.

## LEAK TEST

Whenever doing any type of repair on jet pump, a leak test should be done to check for leakage.

Proceed as follows:

- Remove impeller cover. Install the pressure cap (P/N 529 035 843) on pump housing.
- Connect pump includes in the vacuum/pressure pump kit (P/N 529 031 800) to fitting.
- Pressurize pump to a maximum of 70 kPa (10 PSI).

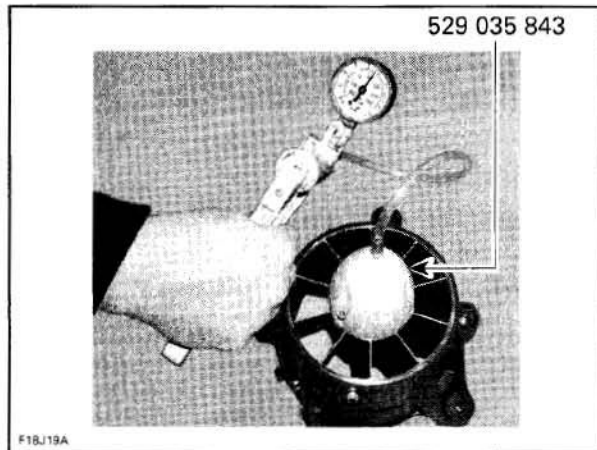

- Pump must maintain this pressure for at least 5 minutes.

**CAUTION:** Repair any leak, failure to correct a leak will lead to premature wear of pump components.

**NOTE:** If there is a pressure drop spray soapy water around cover. If there are no bubbles, impeller shaft, impeller shaft seal, or jet pump housing is leaking through porosity and has to be replaced. Jet pump unit has to be disassembled. There may be 2 or 3 bubbles coming out from the area of sleeve and its seal. This small leak is acceptable. Leaks from other areas must be repaired.

- Disconnect pump and remove pressure cap.
- Reinstall impeller cover with 3 new self-locking screws. Push cover against pump housing while tightening screws.

## PROCEDURES

**NOTE:** Whenever removing a part, visually check for damage such as: corrosion, crack, split, break, porosity, cavitation, deformation, distortion, heating discoloration, wear pattern, defective plating, missing or broken balls in ball bearing, water damage diagnosed by black-colored spots on metal parts, etc. Renew any damaged part. As a quick check, manually feel clearance and end play, where applicable, to detect excessive wear.

## SACRIFICIAL ANODE

**GTI rental, GTX Limited, GTX Supercharged, RXP and RXT Models**

### Inspection

Check for wear. If worn more than half, replace anode.

### Removal

Unscrew sacrificial anode bolt then remove anode.

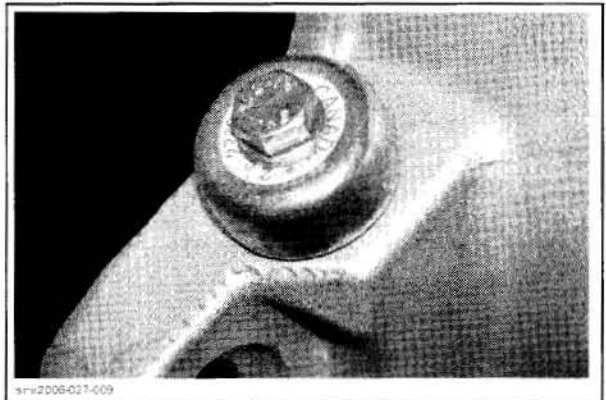

### Installation

The installation is the reverse of the removal procedure.

## VENTURI

### Removal

**NOTE:** In this procedure, the venturi is removed as an assembly with the reverse gate and the steering nozzle.

**GTX Series and RXT Models**

Unplug O.P.A.S. hose from filter.

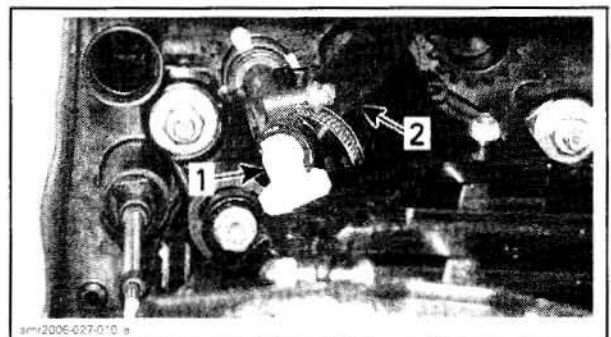

1. Filter
2. O.P.A.S. hose

**RXP Models**

Disconnect VTS link rod.



## Section 07 PROPULSION

### Subsection 01 (JET PUMP)

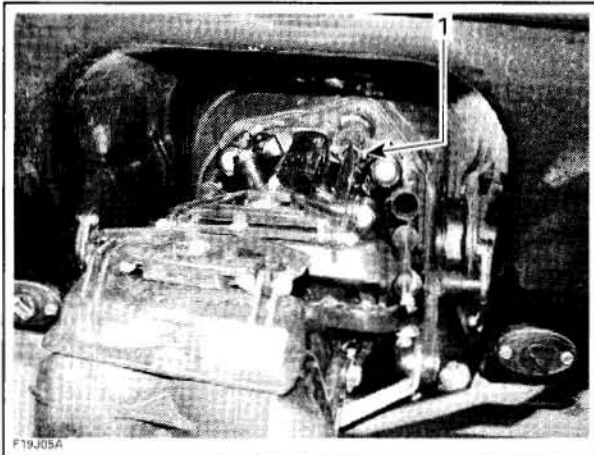

1. Link rod

#### All Models

Disconnect steering and reverse cables.

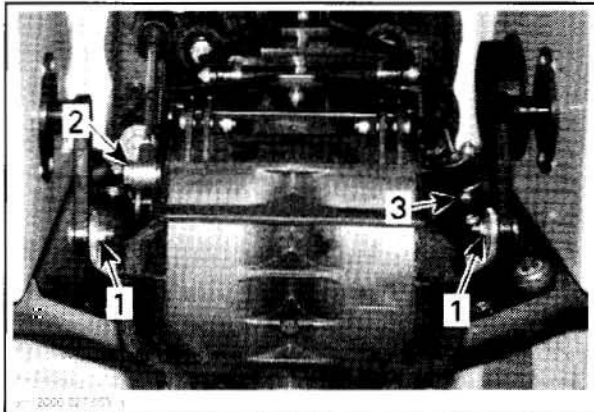

1. O.P.A.S. "U" lever screws
2. Reverse cable
3. Steering cable

Remove O.P.A.S. "U" lever screws.

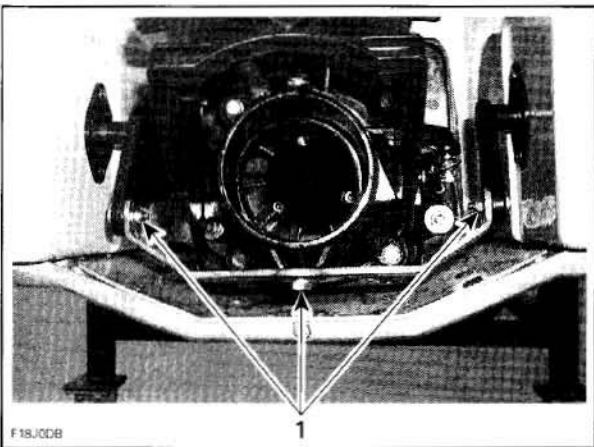

#### TYPICAL

1. "U" lever screws

Remove bolts securing venturi to jet pump housing.

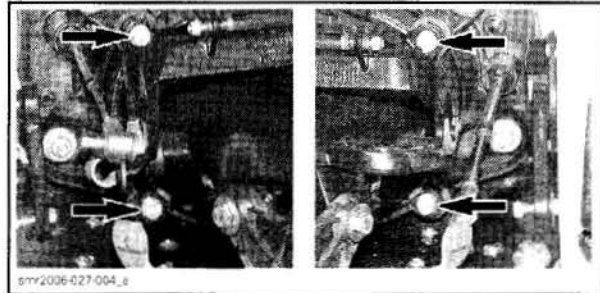

#### Installation

The installation is the reverse of the removal procedure. Pay attention to the following.

If needed, install new O-rings around bailer passages.

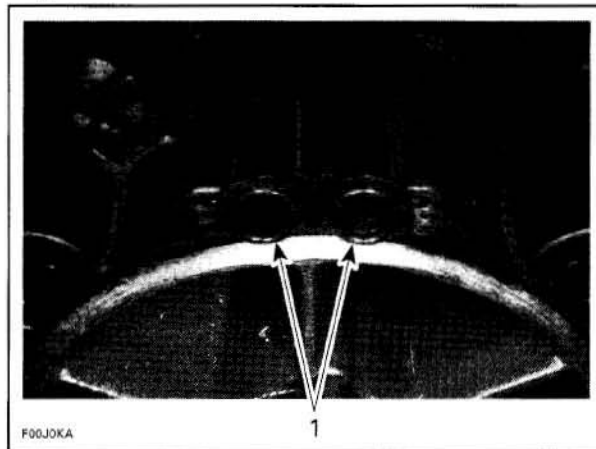

1. O-rings

Position venturi with bailer passages on top.

Apply Loctite 243 (blue) (P/N 293 800 060) on threads of venturi bolts.

Install venturi bolts and flat washers then torque to 21 N•m (16 lbf•ft).

#### JET PUMP HOUSING

**NOTE:** The jet pump housing can be removed as an assembly with the reverse gate, nozzle and venturi. This is the preferred procedure when either the drive shaft or engine removal is required.

#### Removal

Remove venturi, see procedure above.

**NOTE:** To remove jet pump as an assembly, follow venturi removal procedure but do not unscrew venturi from jet pump housing.

## Section 07 PROPULSION

### Subsection 01 (JET PUMP)

Remove nuts or bolts that attach jet pump housing to pump support.

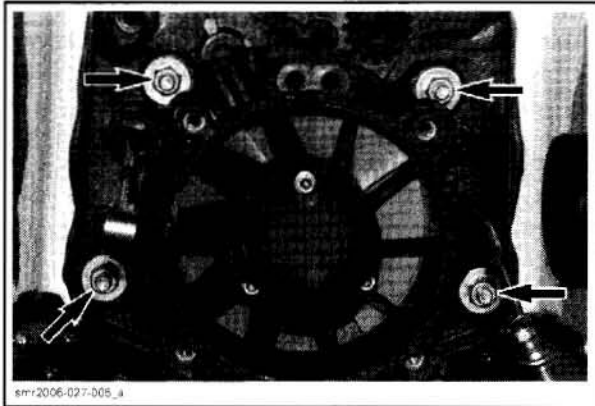

Remove jet pump with a wiggle movement.

**CAUTION:** When removing pump unit, shims could have been installed between hull and pump housing. Be sure to reinstall them otherwise engine and jet pump alignment will be altered.

When removing jet pump from vehicle, install the drive shaft holder (P/N 529 035 986) to support drive shaft and avoid engine oil seal damages.

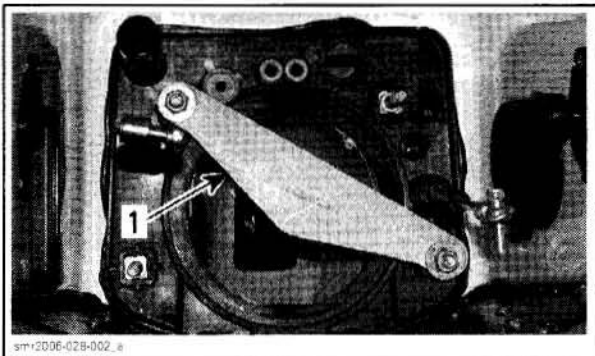

**TYPICAL**  
1. Drive shaft holder

### Inspection and Cleaning

Carefully check water passages. Blow low pressure compressed air through them and make sure they are clear.

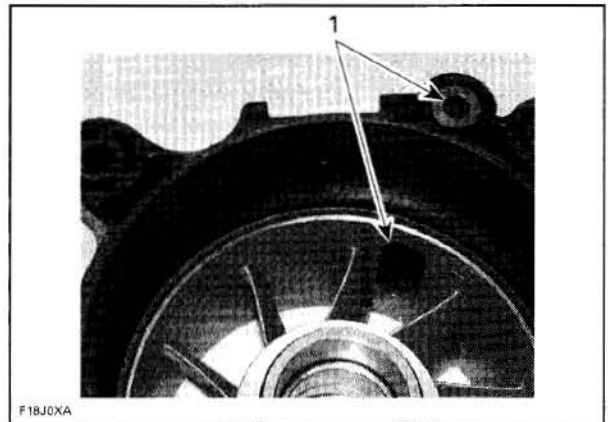

1. Water passages

### Installation

Properly clean all threads.

Remove all O-rings and clean parts in a solvent.

Brush and clean impeller splines and drive shaft splines with pulley flange cleaner (P/N 413 711 809) or equivalent. Free threads and splines from any residue.

The water flow is controlled by a reducer located between the jet pump support and the jet pump on the inlet side. The reducer is color coded according to watercraft model. See table below.

MODEL	REDUCER COLOR
All Models except GTX Supercharged	Yellow
GTX Supercharged	Red

Make sure that the reducer is installed as shown.

**CAUTION:** Misinstallation can cause overheating and damage to exhaust system.

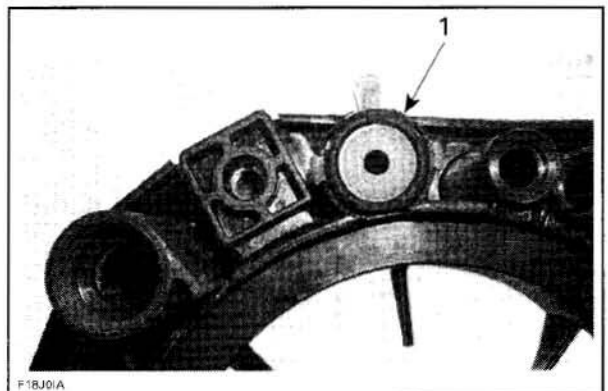

1. Color-coded reducer



## Section 07 PROPULSION

### Subsection 01 (JET PUMP)

Generously apply XP-S synthetic grease (P/N 293 550 010) on drive shaft splines.

Install jet pump. If necessary, wiggle jet pump to engage drive shaft splines in impeller.

**CAUTION:** Some watercraft require a shim between hull and pump; if shim has been removed at pump removal, be sure to reinstall it, otherwise engine alignment will be altered.

Apply Loctite 243 (blue) (P/N 293 800 060) on stud threads or screws (depending on the model) of jet pump housing.

On models with aluminum housing, ensure to re-install bushings in fastener holes.

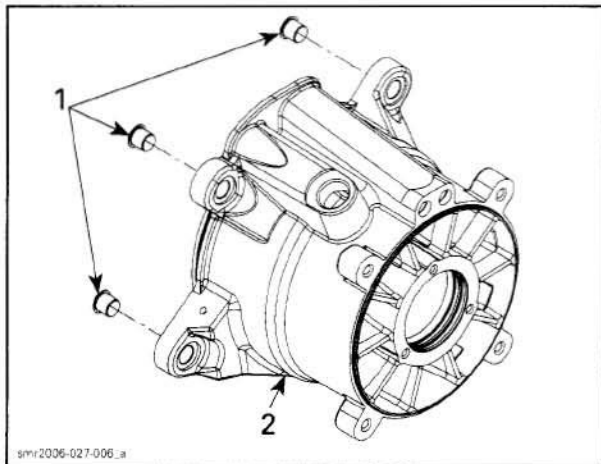

1. Bushings
2. Aluminum housing

Install nuts or bolts. Tighten as per the following sequence.

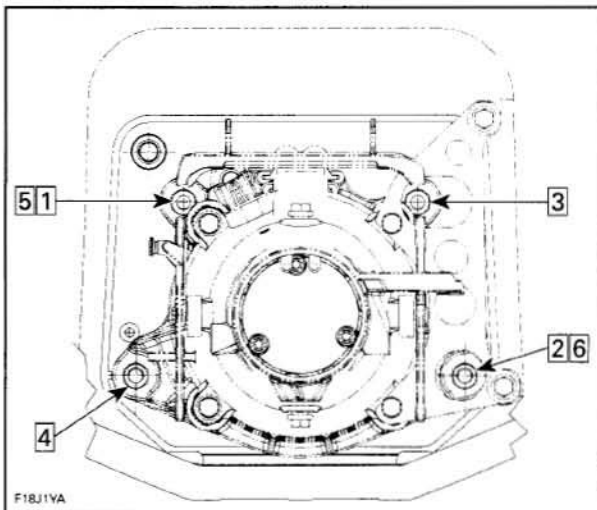

**TYPICAL**  
From 1 to 2: 16 N•m (12 lbf•ft)  
From 3 to 6: 31 N•m (23 lbf•ft)

**NOTE:** Slightly lubricate wear ring with XP-S Lube (P/N 293 600 016) to minimize friction during initial start.

Reconnect O.P.A.S. hose. Torque clamp screw to 1.7 N•m (15 lbf•in).

Fasten O.P.A.S. "U" lever to nozzle and side levers. Apply Loctite 243 (blue) (P/N 293 800 060) on screw threads (or use new self-locking screws). Torque center screw to 20 N•m (15 lbf•ft) and side screw to 7 N•m (62 lbf•in).

## IMPELLER COVER

### Removal

With pump housing in vertical position, remove 3 retaining screws.

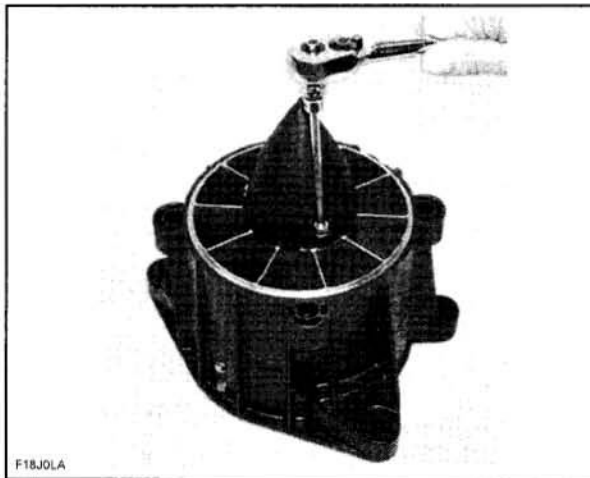

Using a fiber hammer, gently tap impeller cover to release it from jet pump housing. Use flat screwdriver to remove cover.

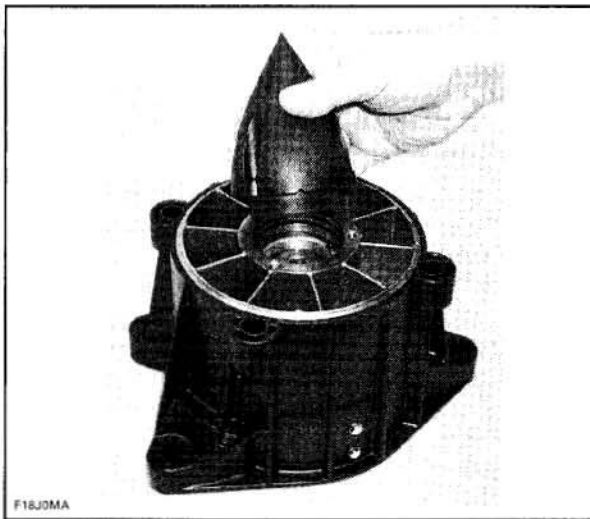

Remove both O-rings.

## Section 07 PROPULSION

### Subsection 01 (JET PUMP)

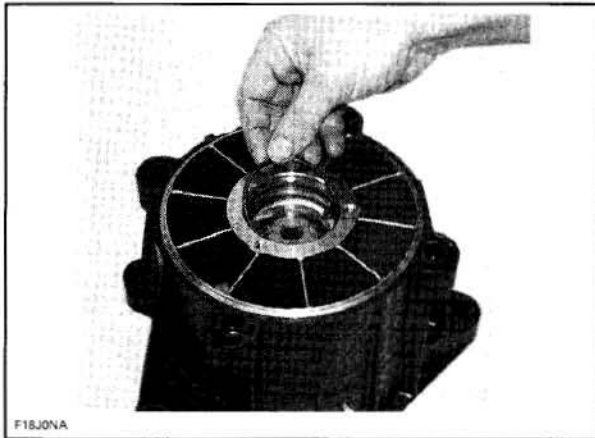

#### Inspection

Check for presence of water in cover and bearing. If so, replace seal and sleeve on impeller side. Also replace O-rings and/or impeller cover.

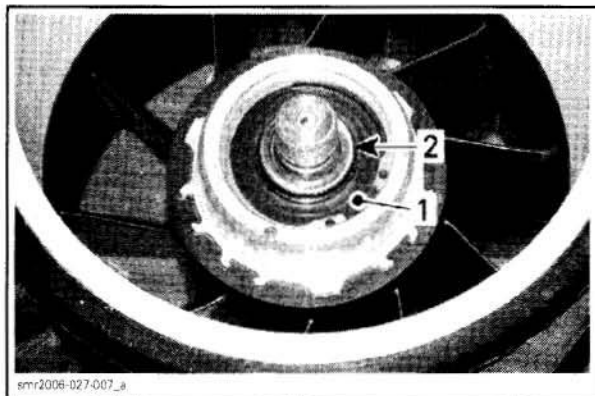

1. Seal
2. Sleeve

Perform a leak test. Refer to *LEAK TEST* at the beginning of this section.

#### Installation

Install 2 new O-rings in their respective groove.

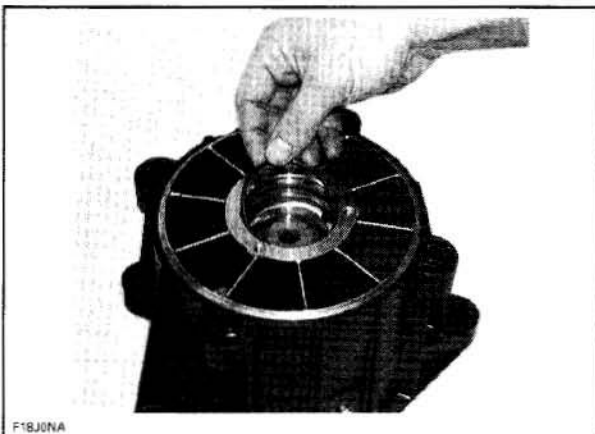

Make sure the cover has the correct amount of grease. When the jet pump is overhauled, put the rest of the grease from the tube used in the cover (approximately 26 grams).

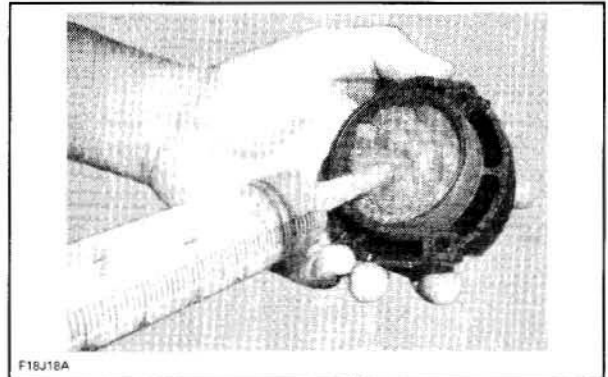

*TYPICAL*

Install impeller cover with new self-locking screws. Torque to 7.5 N•m (66 lbf•in). Push cover against pump housing while tightening screws. Make sure O-rings are positioned correctly and they are not damaged when pushing the cover.

## IMPELLER

#### Removal

Remove jet pump housing. Refer to *JET PUMP HOUSING* in this section.

Remove impeller cover. Refer to *IMPELLER COVER* in this section.

Remove impeller boot by turning it clockwise.

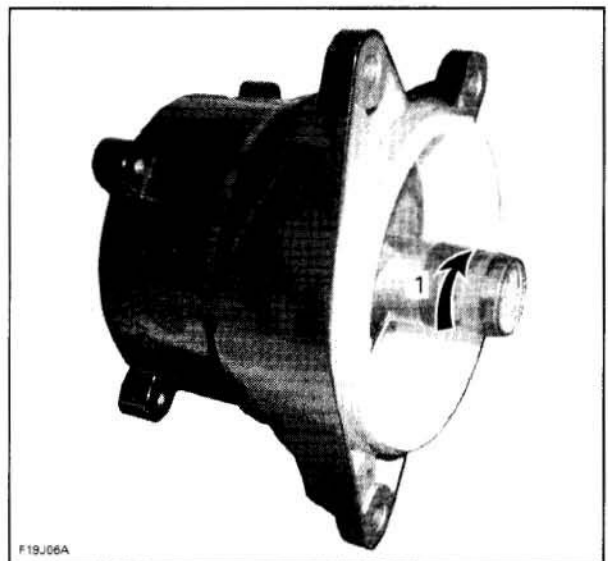

1. Unscrew clockwise



**Section 07 PROPULSION**  
**Subsection 01 (JET PUMP)**

Mount the proper impeller remover/installer in a vise.

MODEL	TOOL
GTI Series, GTX, GTX Wake and GTX Supercharged	Impeller remover/installer (P/N 529 035 820)
GTX Limited, RXP and RXT	Impeller remover/installer (P/N 529 035 956)

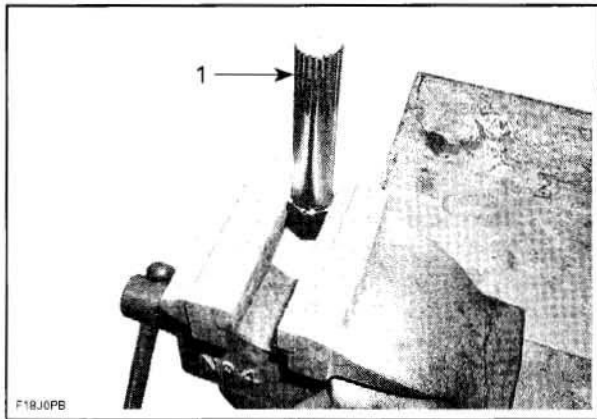

1. Impeller remover/installer

Install jet pump housing over this tool.



Using a 12 mm Allen key, unscrew the impeller.  
**NOTE:** It may be needed to heat the impeller to release the threads.

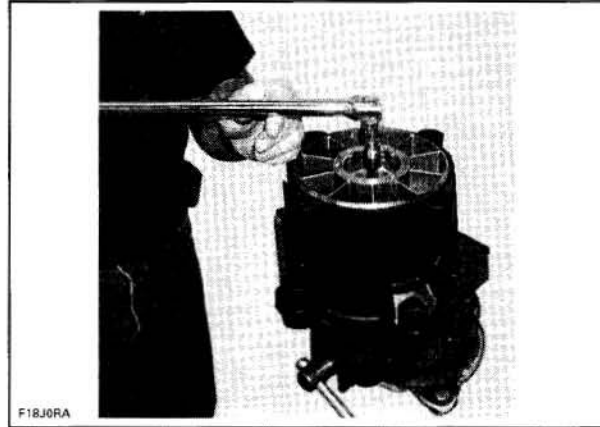

**CAUTION:** Never use any impact wrench to loosen impeller.

To remove impeller, apply a rotating movement and pull at same time. Slide impeller out of housing.

**Inspection**

Check impeller boot for damages. Replace if necessary.

Visually inspect impeller splines. Check for wear or deformation. Renew parts if damaged.

**NOTE:** Check also the drive shaft condition. Refer to *DRIVE SYSTEM*.

Examine impeller in wear ring for distortion.

Check if blade tips are blunted round, chipped or broken. Such impeller is unbalanced and will vibrate and damage wear ring, impeller shaft, shaft seal or bearings. Renew if damaged.

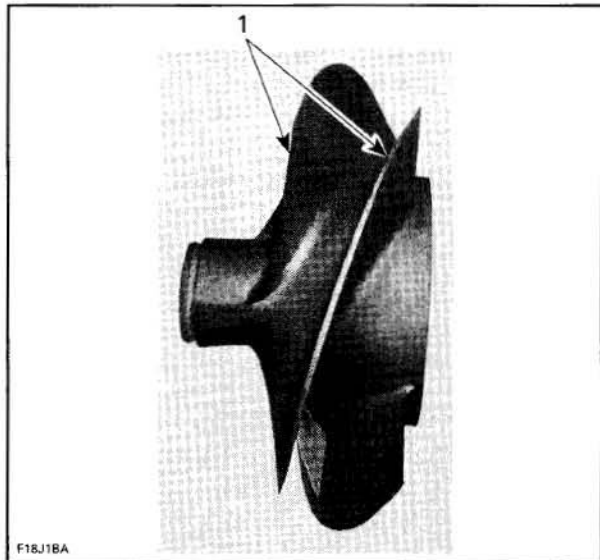

1. Replaced if blunted round or damaged

Check impeller for cavitation damage, deep scratches or any other damage.

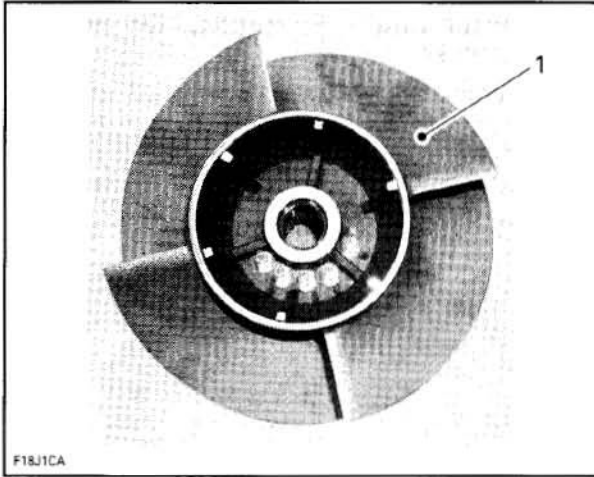

1. Check for cavitation, deep scratches or other damage

### Cleaning

Brush and clean impeller shaft threads, impeller splines and drive shaft splines with pulley flange cleaner (P/N 413 711 809) or equivalent. Free threads and splines from any residue.

### Installation

Apply Loctite 767 (antiseize lubricant) (P/N 293 800 070) on impeller shaft.

Apply XP-S Lube (P/N 293 600 016) on the wear ring surface. Start screwing the impeller on its shaft. If impeller is too tight, use the impeller shaft pusher (P/N 529 035 955) to turn impeller to machine wear ring before installing on vehicle. Make sure to turn it smooth enough so that engine starter should turn it.

Mount the proper impeller remover/installer in a vise.

MODEL	TOOL
GTI Series, GTX, GTX Wake and GTX Supercharged	Impeller remover/installer (P/N 529 035 820)
GTX Limited, RXP and RXT	Impeller remover/installer (P/N 529 035 956)

Install partially screwed impeller on it.

Use a 12 mm Allen key to torque impeller shaft to 125 N•m (92 lbf•ft) then remove tool.

**CAUTION:** Never use any impact wrench to tighten impeller shaft.

Apply XP-S synthetic grease (P/N 293 550 010) on impeller boot threads.

## WEAR RING

### Inspection

Check wear ring for deep scratches, irregular surface or any apparent damage.

If impeller/wear ring clearance is too large and impeller is in good shape, renew wear ring.

### Removal

Remove jet pump housing and impeller. See procedures above.

On plastic pump housing, remove the screws retaining wear ring in the jet pump housing.

Place jet pump housing in a vise with soft jaws. It is best to clamp housing using a lower ear.

Cut wear ring at two places.

**CAUTION:** When cutting ring, be careful not to damage jet pump housing.

**NOTE:** Wear ring can be cut using a jigsaw, a small grinder or a low clearance hacksaw such as Snap-on HS3 or equivalent.

After cutting ring, insert a screwdriver blade between jet pump housing and ring outside diameter.

Push ring so that it can collapse internally.

Pull ring out.

### Installation

To install ring in housing, use a square steel plate of approximately 180 x 180 mm x 6 mm thick (7 x 7 in x 1/4 in) and a press.

Manually engage ring in housing making sure it is equally inserted all around. Press ring until it seats into bottom of housing.



## Section 07 PROPULSION

### Subsection 01 (JET PUMP)

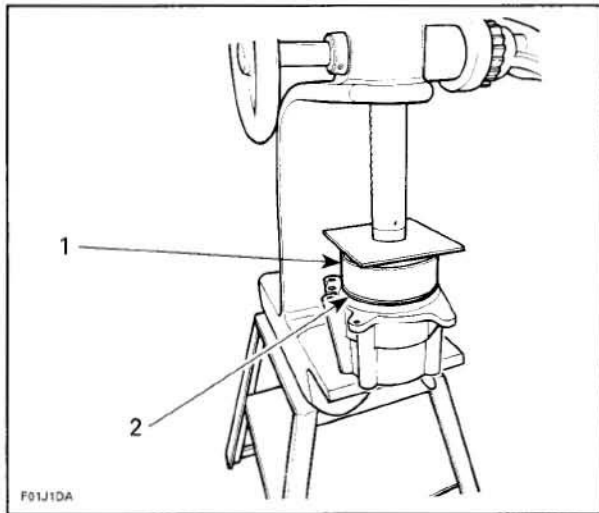

1. Rounded edge
2. Press wear ring

If a press is not readily available, a piece of wood such as a 2 x 4 in x 12 in long, can be used.

Manually engage ring in housing making sure it is equally inserted all around. Place wood piece over ring. Using a hammer, strike on wood to push ring. Strike one side then rotate wood piece about 90° and strike again. Frequently rotate wood piece so that ring slides in evenly until it seats into bottom of housing.

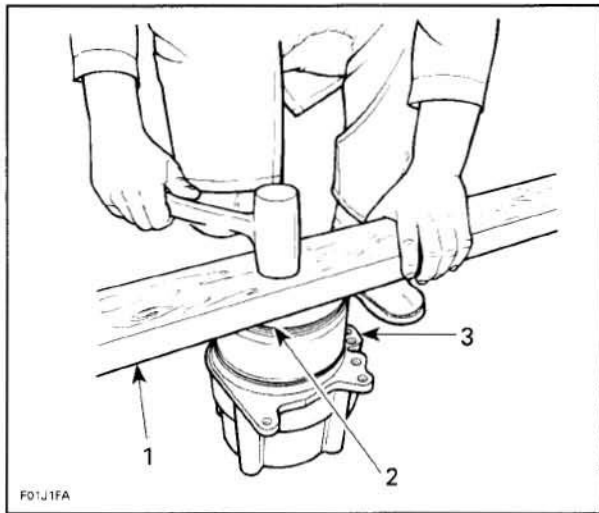

1. Piece of wood
2. Rounded edge
3. Wear ring

#### Models with a Plastic Pump Housing

After wear ring installation, install wear ring screws. Using their holes in jet pump housing as a drilling guide, drill 4 mm (5/32 in) diameter holes in wear ring. The depth of holes does not exceed 5 mm (3/16 in).

**CAUTION:** Drill carefully paying attention not to damage threads in jet pump housing. Drilling holes prior to screw installation will avoid wear ring deformation. Do not drill through wear ring.

Install screws and torque to 6 N•m (53 lbf•in).



TYPICAL

#### All Models

Install all other removed parts.

## IMPELLER SHAFT AND BEARING

### Inspection

#### Wear

**IMPORTANT:** Make sure to reassemble ball cage, bearing inner and outer races to their original position.

Inspect ball bearing. Check for corrosion, scoring, pitting, chipping or other evidence of wear.

With your finger nail, feel contact surface of sleeve. If any irregular surface is found, renew sleeve and seal.

Install bearing, then install impeller shaft and rotate it. Make sure it turns smoothly.

#### Radial Play

Radial play is critical for jet pump unit life span.

Radial play of impeller shaft is checked with shaft in housing, with impeller.

Retain housing in a soft jaw vise making sure not to damage housing lug.

Set a dial gauge and position its tip onto metal end, close to end of threads.

Move shaft end up and down. Difference between highest and lowest dial gauge reading is radial play.

**Section 07 PROPULSION**  
**Subsection 01 (JET PUMP)**

The radial play should be 0 (zero).

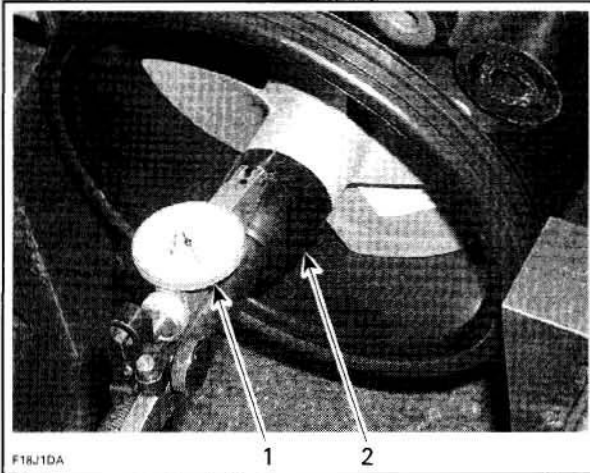

**TYPICAL — MEASURING IMPELLER SHAFT RADIAL PLAY**  
 1. Dial gauge  
 2. Measure close to threads at shaft end

Excessive play can come either from worn bearing or damaged jet pump housing bearing surface.

**Removal**

Remove impeller cover. See procedure in this section.

Remove impeller.

Remove circlip, seal and shaft sleeve.

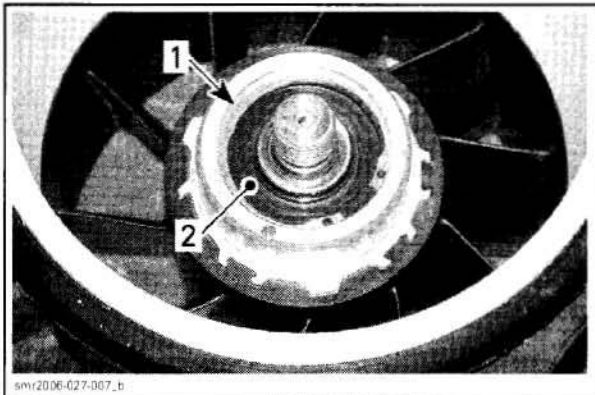

1. Circlip  
 2. Seal

**NOTE:** Ensure to keep shaft sleeve and O-ring in position. The impeller shaft pusher will work against shaft sleeve to properly push bearing out. Use the impeller shaft pusher (P/N 529 035 955) to press out impeller shaft of pump housing. Bearing, will come out with the impeller shaft.

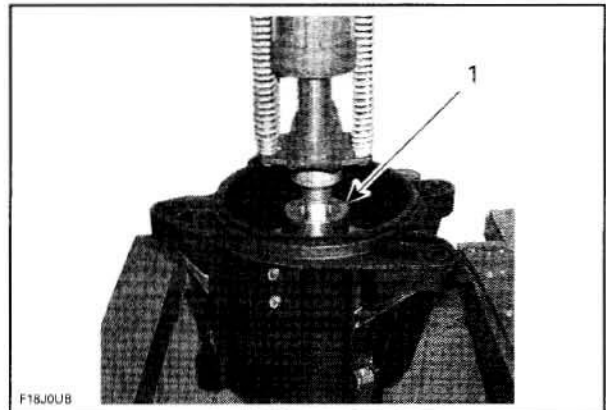
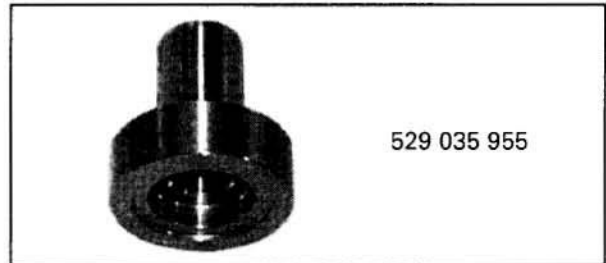

1. Impeller shaft pusher

**CAUTION:** Bearing inner race being in 2 parts, bearing may fall apart during removal.

Use the seal/bearing pusher (P/N 529 035 819) to press out bearing from impeller shaft.

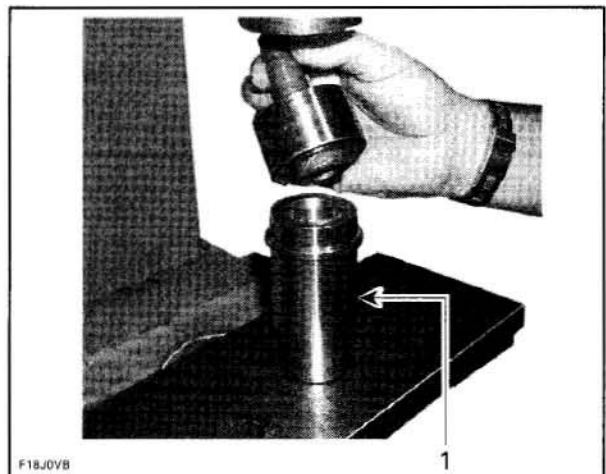

1. Seal/bearing pusher

From the outlet side of pump, use the seal/bearing pusher (P/N 529 035 819) to press out the seal.



## Section 07 PROPULSION

### Subsection 01 (JET PUMP)

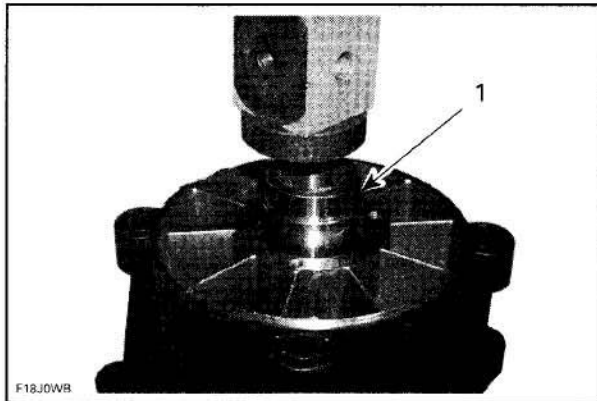
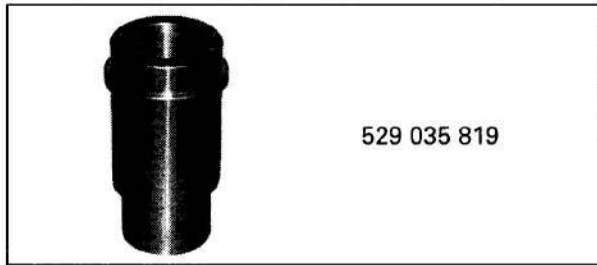

1. Seal/bearing pusher

Remove large O-ring from pump housing.

#### Installation

The installation is essentially the reverse of the removal procedure. However, pay attention to the following.

Using the seal/bearing pusher (P/N 529 035 819) press the bearing by its inner race on the impeller shaft.

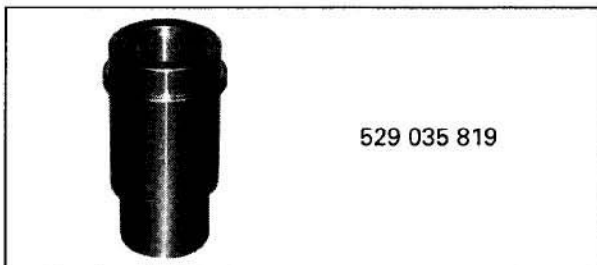

Be careful when removing the plastic retainer from the bearing to avoid the inner races from falling apart. Make sure to reassemble bearing parts to their original position.

The bearing can be installed either side.

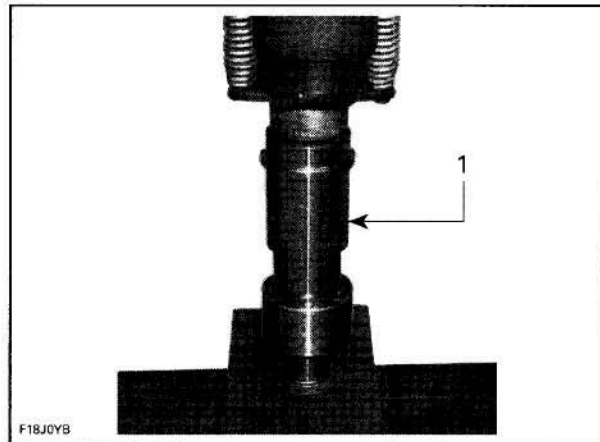

1. Seal/bearing pusher

From the outlet side of pump, press impeller shaft assembly into housing using the impeller shaft pusher (P/N 529 035 955).

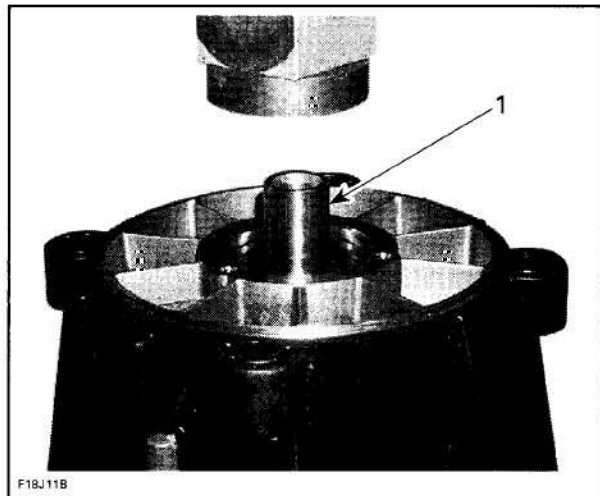
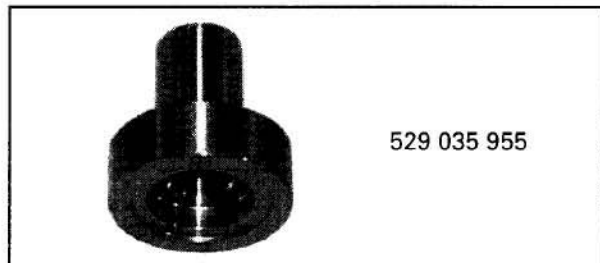

1. Shaft pusher

Coat shaft surface with jet pump bearing grease (P/N 293 550 032).

Install O-ring and shaft sleeve on shaft.

**Section 07 PROPULSION**  
Subsection 01 (JET PUMP)

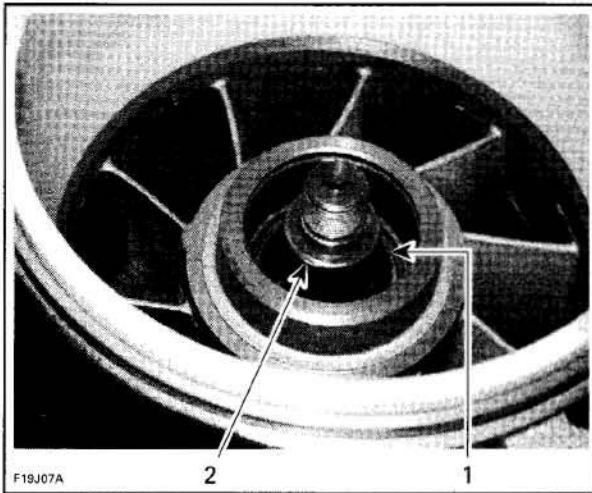

1. O-ring at bottom
2. Shaft sleeve

Apply 4 grams of jet pump bearing grease (P/N 293 550 032) on bearing. Use a new tube of grease each time a jet pump is rebuilt.

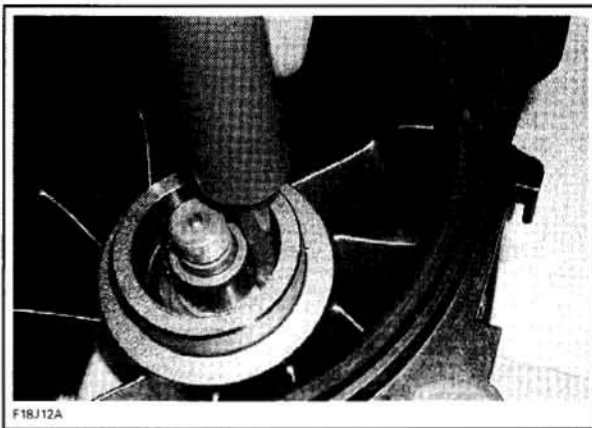

Press **NEW** seal using the seal/bearing pusher (P/N 529 035 819) until tool bottoms. Make sure seal lips are facing up.

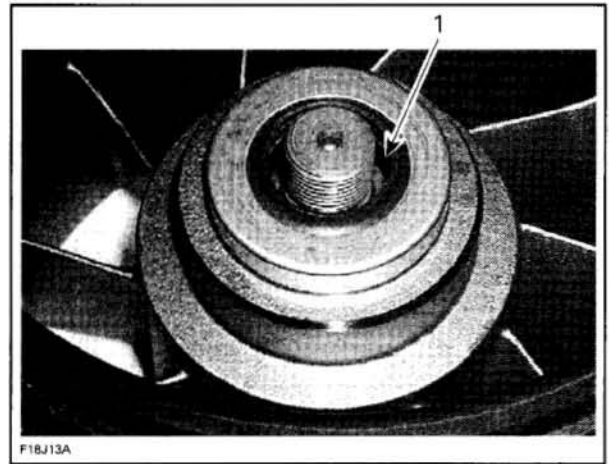

1. Lips facing up

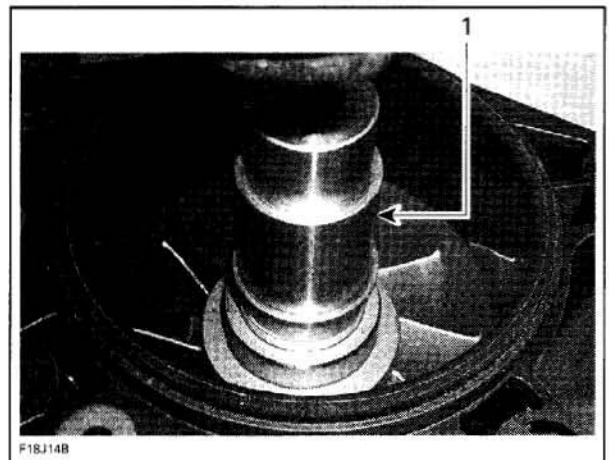

1. Seal/bearing pusher

Install spacer and the other seal. Ensure seal lip is facing up.

Install circlip.

Before installing any other parts, pump can be pressurized to insure proper seal installation. See **LEAK TEST** at the beginning of this section.

Apply 26 grams of jet pump bearing grease (P/N 293 550 032) in the impeller shaft area.



---

**Section 07 PROPULSION**  
Subsection 01 (JET PUMP)

---

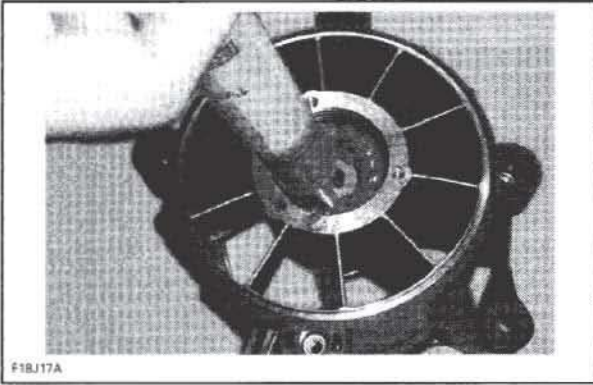

*TYPICAL*

**NOTE:** The remaining grease in the tube will be used for the impeller cover.

# DRIVE SYSTEM

## SERVICE TOOLS

<b>Description</b>	<b>Part Number</b>	<b>Page</b>
drive shaft circlip remover .....	529 036 026 .....	278
drive shaft holder tool.....	529 035 986 .....	277, 283
Drive shaft/floating ring tool .....	529 035 841 .....	279, 283
Drive shaft/floating ring tool .....	529 035 987 .....	279, 283
PTO seal support tool .....	529 035 842 .....	278, 282

## SERVICE PRODUCTS

<b>Description</b>	<b>Part Number</b>	<b>Page</b>
anticorrosion spray .....	219 700 304 .....	277, 281
XP-S Lube .....	293 600 016 .....	279
XP-S synthetic grease.....	293 550 010 .....	281



**Section 07 PROPULSION**  
Subsection 02 (DRIVE SYSTEM)

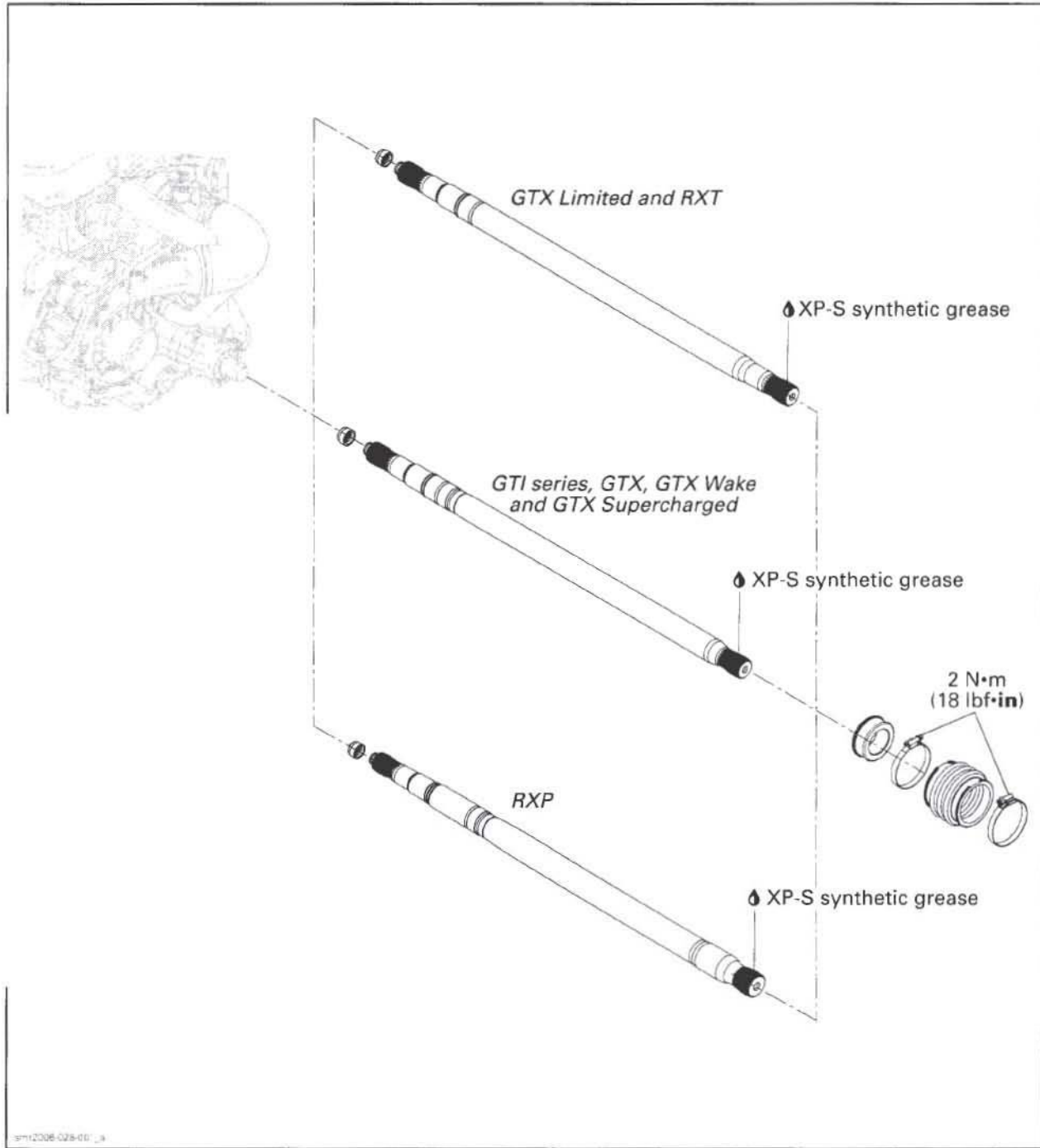

## GENERAL

Jet pump must be removed to replace any components of the drive system. Refer to *JET PUMP* for removal procedure.

During assembly/installation, use torque values and service products as in the exploded view.

Clean threads before applying a threadlocker. Refer to *SELF-LOCKING FASTENERS* and *LOCTITE APPLICATION* at the beginning of this manual for complete procedure.

### **⚠ WARNING**

Torque wrench tightening specifications must strictly be adhered to. Locking devices (e.g.: locking tabs, elastic stop nuts, self-locking fasteners, cotter pins, etc.) must be installed or replaced with new one where specified. If the efficiency of a locking device is impaired, it must be renewed.

## MAINTENANCE

### CORROSION PROTECTION

To prevent possible drive shaft corrosion in salt water, apply anticorrosion spray (P/N 219 700 304) as per interval in *MAINTENANCE CHART*.

### **⚠ WARNING**

Always work in a well ventilated area. Carefully read application instructions on product can.

Drive shaft should be dry and clean prior to applying the anticorrosion product.

Place a plastic sheet underneath hull to recover the excess of sprayed anticorrosion product.

From underneath hull, spray the anticorrosion product through the intake grate all over the visible portion of drive shaft.

Dispose of the soiled plastic sheet as per your local environmental regulations.

From inside bilge, lift rubber protector to expose PTO seal assembly.

**NOTE:** On **Supercharged models**, remove inlet hose from supercharger to gain access.

Cover carbon seal ring and floating ring with a rag or plastic wrap to prevent the anticorrosion product to reach the carbon ring. Place a rag on bottom of hull to recover the excess of sprayed anticorrosion product. Spray the visible portion of drive shaft. When done, dispose soiled rag as per your local environmental regulations.

Install inlet hose to supercharger.

Reposition rubber protector.

Wait 2 hours prior to using the watercraft to allow the anticorrosion product to dry.

## PROCEDURES

### DRIVE SHAFT

#### Removal

**NOTE:** When drive shaft will be removed, some oil will flow out. To prevent it, start engine, run at 4000 RPM for 10 seconds and stop engine at this RPM. This will move oil out of PTO housing into oil tank. If engine cannot be started, remove oil from the PTO area by following the procedure in *PTO HOUSING REMOVAL* of the *PTO HOUSING AND MAGNETO* section.

Remove jet pump. Refer to *JET PUMP*.

Install the drive shaft holder tool (P/N 529 035 986) on pump support. Secure it with jet pump housing fastener (nuts/bolts and washers).

**NOTE:** This is necessary so the drive shaft cannot move rearwards when using the drive shaft/floating ring tool.

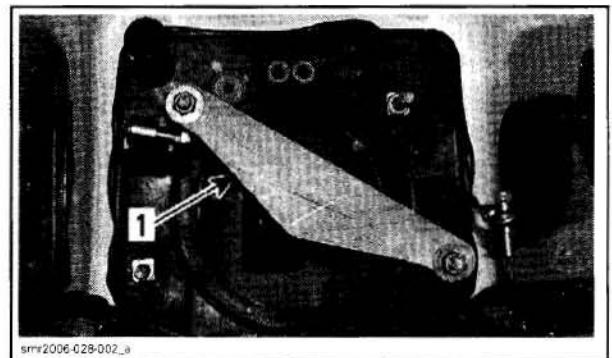

**TYPICAL**  
1. Drive shaft holder

Remove seat.

#### **RXP Models**

Remove engine cover.



## Section 07 PROPULSION

### Subsection 02 (DRIVE SYSTEM)

#### GTX Series and RXT Models

Detach coolant expansion reservoir from vent tube support then move away.

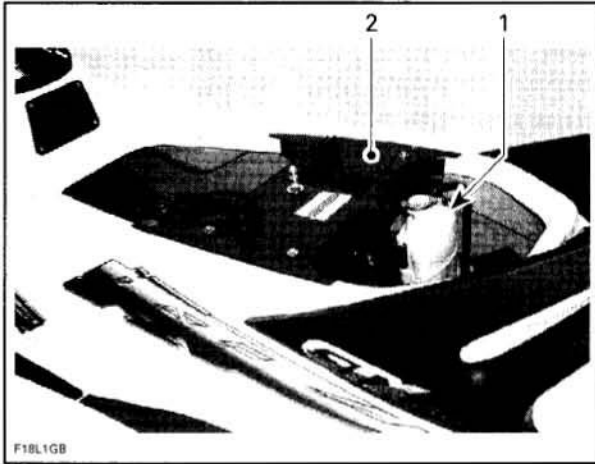

#### TYPICAL

1. Detach expansion reservoir
2. Remove vent tube support

Detach vent tube.

Remove vent tube support.

#### GTX Limited, GTX Supercharged, RXP and RXT Models

Remove supercharger. Refer to *SUPERCHARGER* in *ENGINE* section.

#### All Models

**NOTE:** Use this sequence to minimize the amount of movement the drive shaft will slide back into PTO seal assembly.

Lift rubber protector to expose PTO seal assembly. Install the PTO seal support tool (P/N 529 035 842) on bottom of PTO seal assembly as shown.

**CAUTION:** Strictly follow this procedure otherwise damage to component might occur.

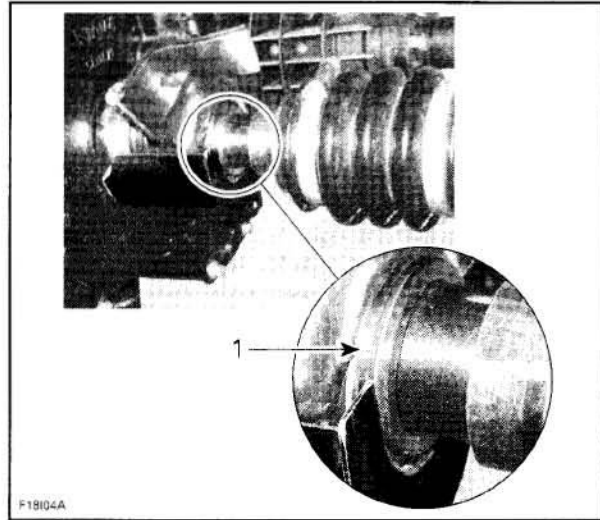
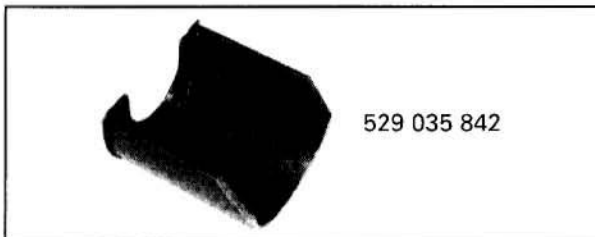

1. Insert in groove of PTO seal assembly

Due to configuration of some models, it may be necessary to disconnect EGTS sensor to make room.

Using the drive shaft circlip remover (P/N 529 036 026), push the floating ring rearwards to expose the circlip. This step is done to ensure floating ring is free and not stuck on the drive shaft. Do not remove circlip at this time.

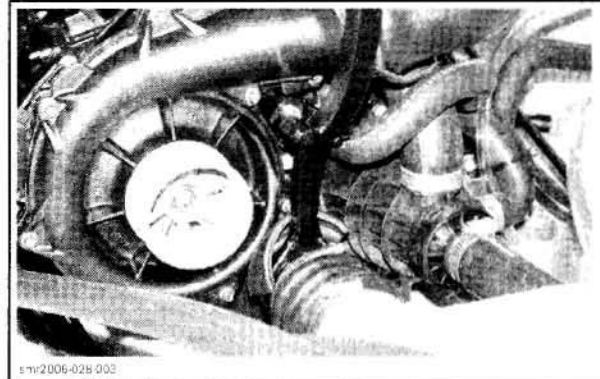
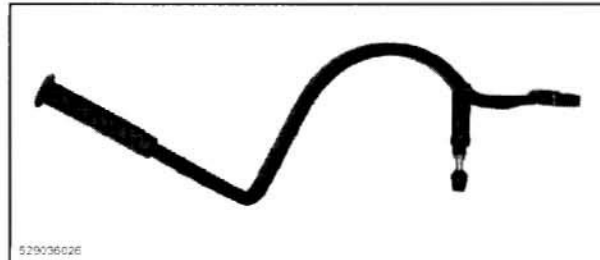

**NOTE:** Place the fork of drive shaft circlip remover against floating ring and the adjustable arm on engine. Move the tool handle toward the front of vehicle to push floating ring.

Remove the drive shaft circlip remover and the drive shaft holder.

**Section 07 PROPULSION**  
Subsection 02 (DRIVE SYSTEM)

Use the drive shaft/floating ring tool. Refer to the following table to use the appropriate tool according to the model.

MODEL	TOOL
GTX Limited, RXP and RXT	Drive shaft/floating ring tool (P/N 529 035 987)
GTI Series, GTX, GTX Wake and GTX Supercharged	Drive shaft/floating ring tool (P/N 529 035 841)

Install tool as shown.

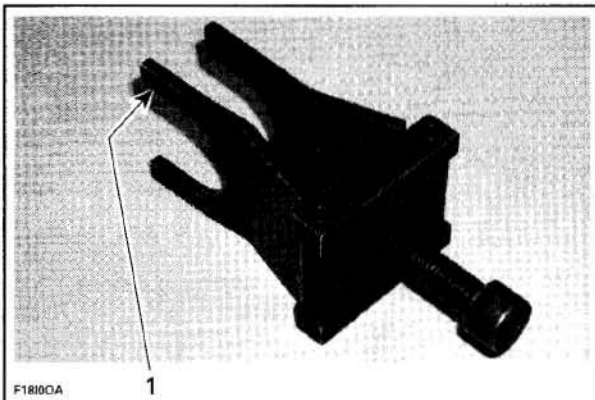

**TYPICAL**  
1. Largest opening on PTO seal side

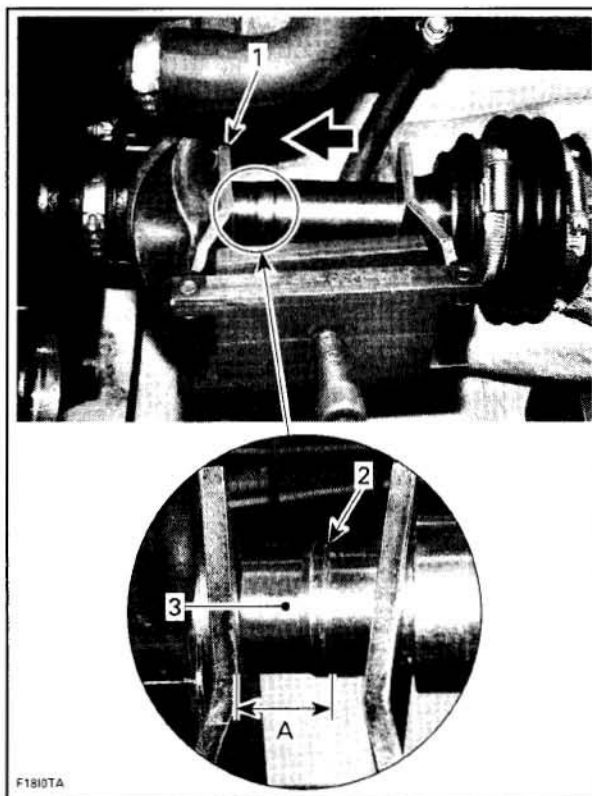

**TYPICAL**  
1. Largest opening here  
2. Telltale groove  
3. Lubricate O-rings contact area  
A. 18 mm (.71 in)

Turn screw clockwise so that the tool pushes the PTO seal forward and the drive shaft to the rear to expose the O-rings contact area. Continue to pull drive shaft out until there is a distance of 18 mm (.71 in) between the telltale groove and the tool edge. Lubricate O-rings contact area with XP-S Lube (P/N 293 600 016).

**NOTE:** This is necessary to ease drive shaft removal later in this procedure.

Remove drive shaft/floating ring tool.

Push drive shaft in and reinstall drive shaft holder tool.



**Section 07 PROPULSION**  
**Subsection 02 (DRIVE SYSTEM)**

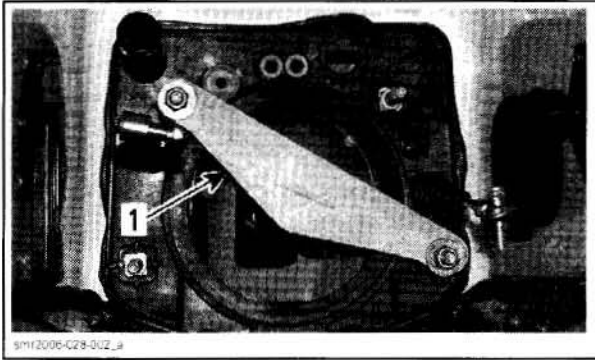

**TYPICAL**  
 1. Drive shaft holder

Reinstall drive shaft/floating ring tool as shown.

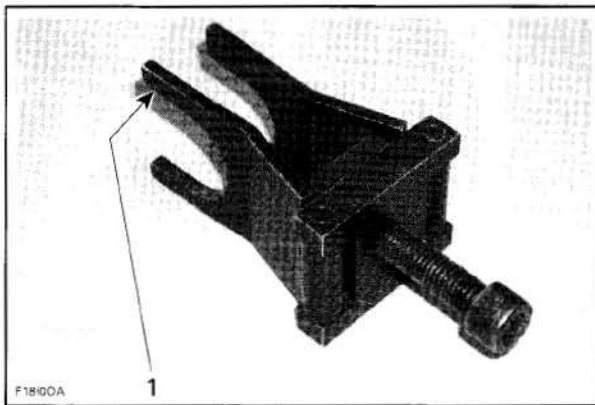

**TYPICAL**  
 1. Largest opening on PTO seal side

Push floating ring rearwards to expose circlip and remove it. Discard circlip.

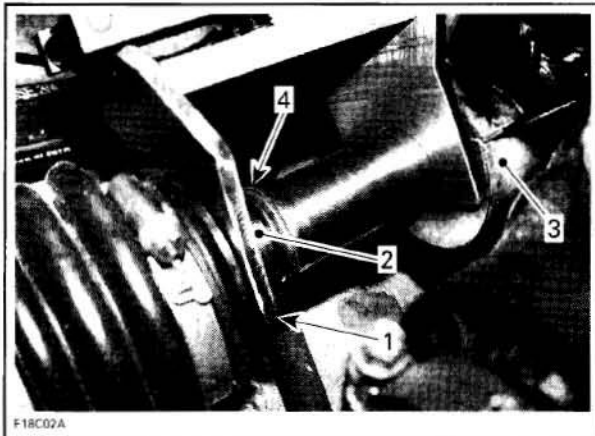

**TYPICAL**  
 1. Largest opening here  
 2. Floating ring  
 3. PTO seal support tool  
 4. Remove circlip

Remove drive shaft holder tool then drive shaft/floating ring tool.

Place rags under PTO housing to prevent spillage. If spillage occurs, clean immediately with the pulley flange cleaner (P/N 413 711 809) to prevent oil stains.

Remove drive shaft.

**NOTE:** A slight jerk to the rear may be required to remove the drive shaft from the PTO seal assembly.

**Inspection and Lubrication**

**Drive Shaft**

Inspect condition of circlip groove. If there is any damage or severe wear, replace drive shaft.

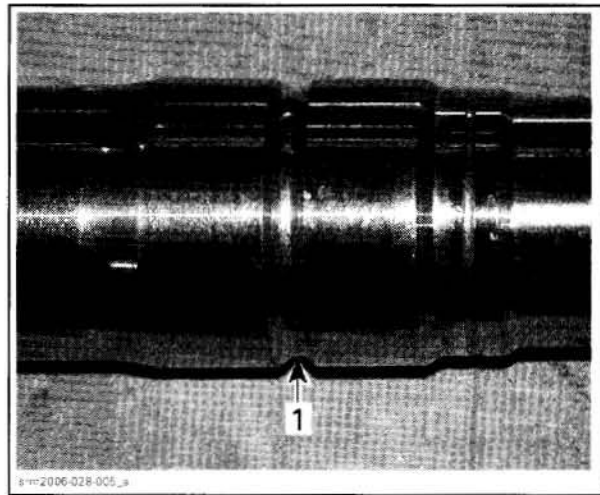

1. Circlip groove

Inspect condition of drive shaft splines. If splines are damaged, replace drive shaft.

With your finger nail, feel machined surface of drive shaft. If any irregular surface is found, renew drive shaft.

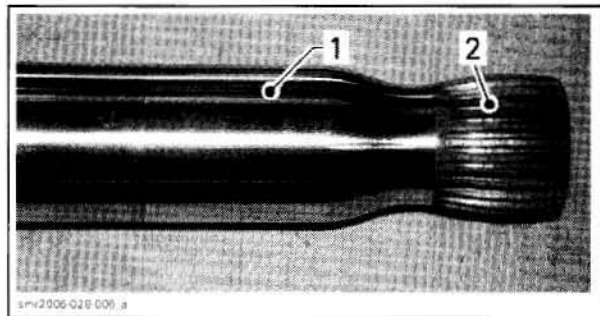

**TYPICAL**  
 1. Surface condition  
 2. Splines condition

Excessive deflection could cause vibration and damage to drive shaft splines, impeller or floating ring.

## Section 07 PROPULSION

### Subsection 02 (DRIVE SYSTEM)

Place drive shaft on V-blocks and set-up a dial gauge in center of shaft. Slowly rotate shaft; difference between highest and lowest dial gauge reading is deflection. Refer to the following illustration.

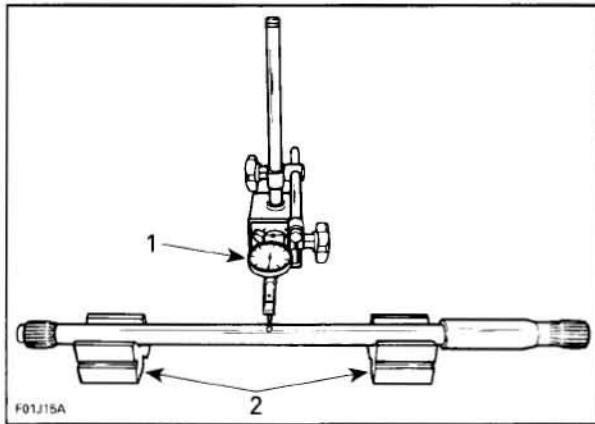

#### MEASURING DRIVE SHAFT DEFLECTION

1. Dial gauge
2. V-blocks

Maximum permissible deflection is 0.5 mm (.020 in).

To prevent possible drive shaft corrosion when the vehicle is used in salt water, apply anticorrosion spray (P/N 219 700 304) on drive shaft where shown.

**NOTE:** Drive shaft should be dry and clean prior to applying the anticorrosion product. If the drive shaft is slightly corroded, a rotating wire brush may be used.

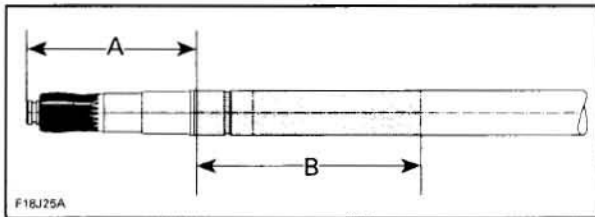

#### ALL MODELS EXCEPT RXP

- A. 89 mm (3.3 in)
- B. 131 mm (5.2 in) — zone to apply anticorrosion product

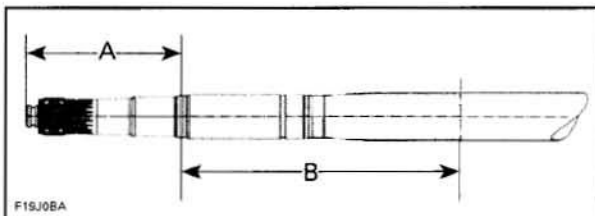

#### RXP MODELS

- A. 101 mm (4 in)
- B. 180 mm (7.1 in) — zone to apply anticorrosion product

### ⚠ WARNING

Always work in a well ventilated area. Carefully read application instructions on product can.

Wait 2 hours prior to using the watercraft to allow anticorrosion product to dry.

#### Floating Ring

Inspect condition of O-rings and contact surface floating ring. Apply a thin coat of XP-S synthetic grease (P/N 293 550 010) on the floating ring O-rings. Do not get grease on floating ring contact surface.

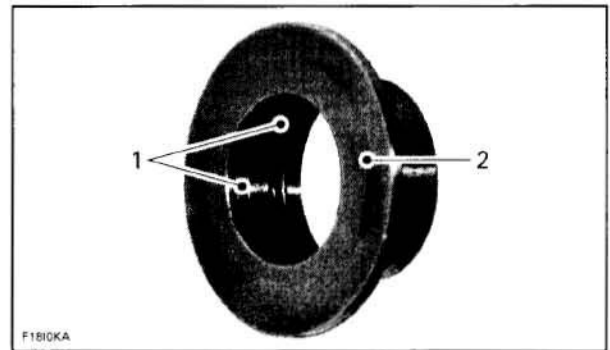

1. XP-S synthetic grease on O-rings
2. No lubrication on contact surface

#### Installation

Before installing drive shaft, discard both O-rings inside PTO seal and install new ones.

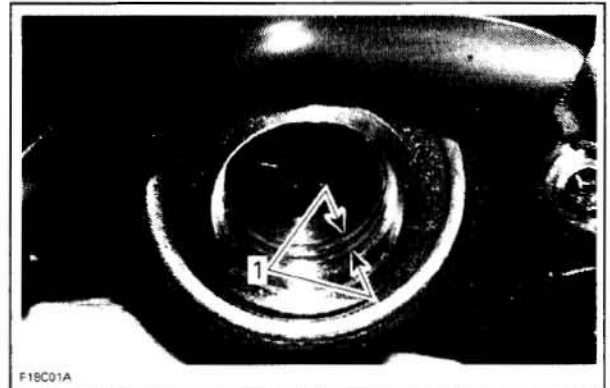

1. O-rings

Inspect PTO seal assembly. The inner sleeve must be flush with outer circumference of the assembly. Otherwise, gently push or tap on inner sleeve until flush.



**Section 07 PROPULSION**  
**Subsection 02 (DRIVE SYSTEM)**

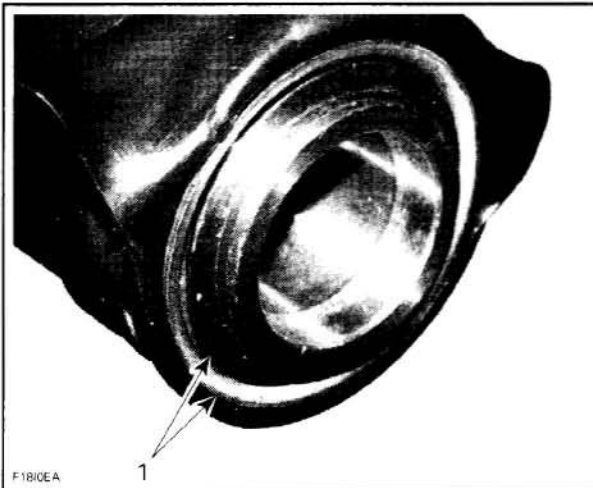

**CORRECT POSITION**  
 1. Inner sleeve flush with outer circumference

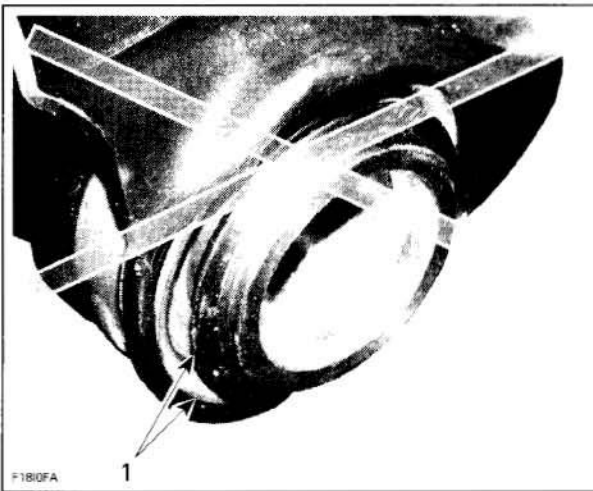

**INCORRECT POSITION**  
 1. Inner sleeve not flush with outer circumference

Remove the damper at the end of drive shaft and replace it with a new one.

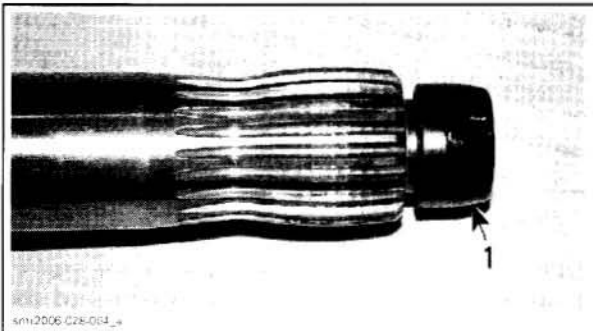

1. Damper

Install the PTO seal support tool (P/N 529 035 842) on PTO seal assembly.

Slide drive shaft far enough to install floating ring.

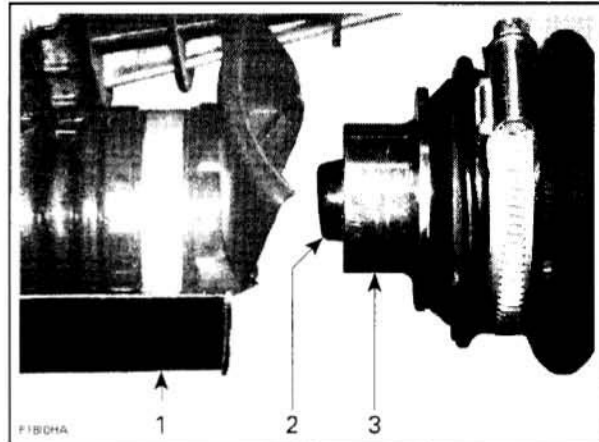

1. PTO seal support  
 2. Drive shaft end  
 3. Insert floating ring on shaft end

Continue pushing drive shaft towards engine carefully guiding it in the PTO seal then in crankshaft splines. It may be necessary to move PTO seal assembly up and down to position it in the same axis as the drive shaft.

**NOTE:** If drive shaft does not enter into the PTO seal, check engine alignment.

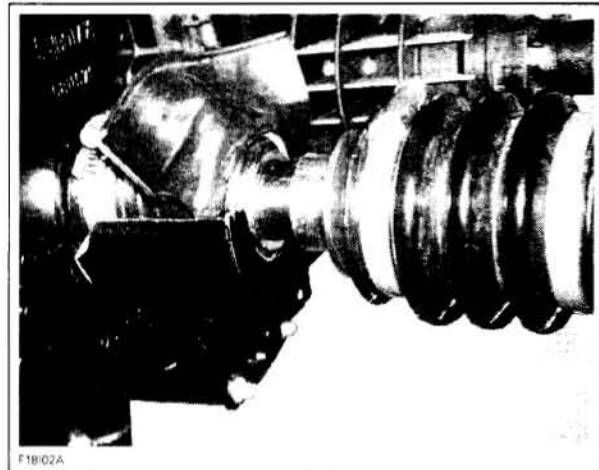

TYPICAL

Maintain PTO seal assembly in the proper position and tap shaft end until it bottoms against engine. At this time, the telltale groove **MUST NOT** be visible. This validates the correct position.

**CAUTION:** If the telltale groove is exposed, the installation is wrong and PTO seal assembly will be pressed into crankshaft splines which could rub a hole in seal thus creating an oil leak.

**Section 07 PROPULSION**  
Subsection 02 (DRIVE SYSTEM)

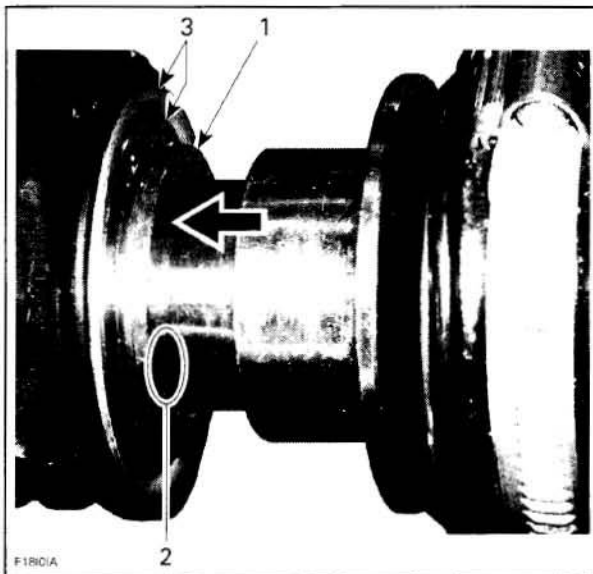

**CORRECT INSTALLATION**  
1. PTO seal assembly  
2. Shaft pushed in, hiding telltale groove  
3. Inner sleeve flush with outer circumference

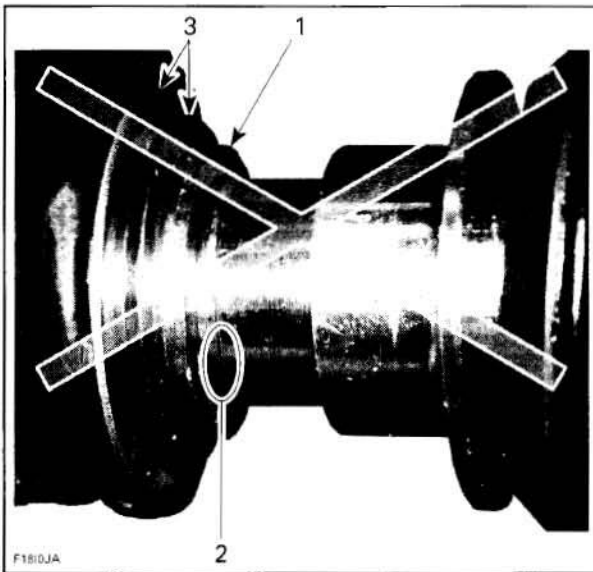

**IMPROPER INSTALLATION**  
1. PTO seal assembly  
2. Telltale groove visible  
3. Inner sleeve NOT flush with outer circumference

Install the drive shaft holder tool (P/N 529 035 986).

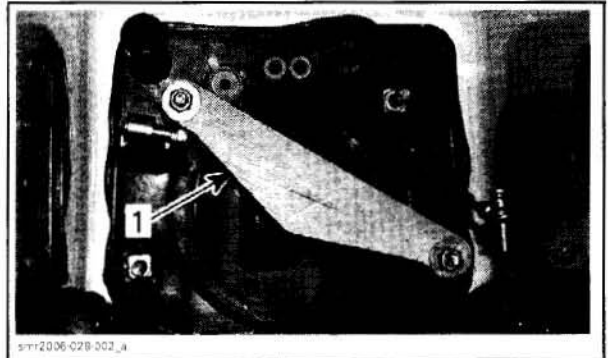

**TYPICAL**  
1. Drive shaft holder

Install drive shaft/floating ring tool as shown. Ensure PTO seal support is still in place.

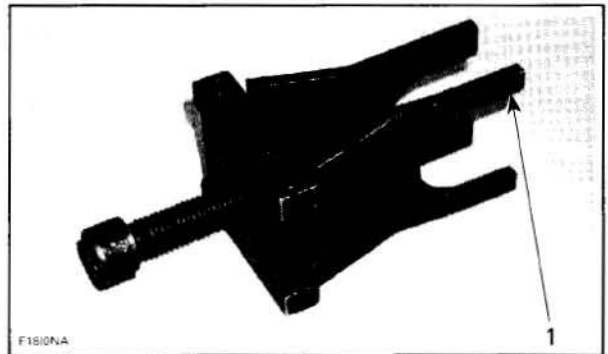

**TYPICAL**  
1. Largest opening on through-hull fitting side

Refer to the following table to use the appropriate tool according to the model.

MODEL	TOOL
GTX Limited, RXP and RXT	Drive shaft/floating ring tool (P/N 529 035 987)
GTI Series, GTX, GTX Wake and GTX Supercharged	Drive shaft/floating ring tool (P/N 529 035 841)

Push floating ring rearwards and install a **NEW** circlip.



## Section 07 PROPULSION

### Subsection 02 (DRIVE SYSTEM)

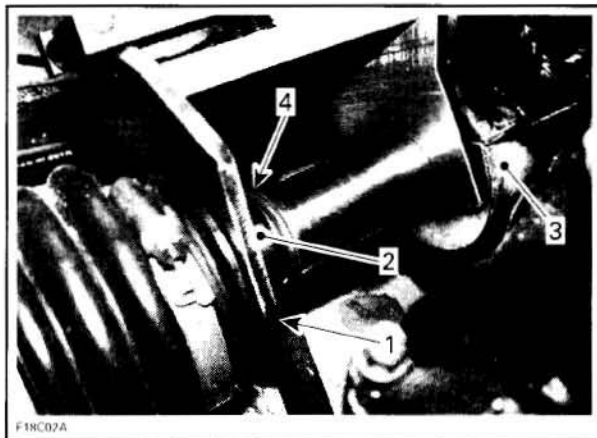

#### TYPICAL

1. Largest opening
2. Floating ring
3. PTO seal support tool
4. Install circlip

Remove drive shaft/floating ring tool, drive shaft holder then PTO seal support.

**NOTE:** Pushing boot rearwards will ease removal of PTO seal support tool.

Now ensure everything is properly positioned:

- telltale groove is not visible
- inner sleeve is flush with outer circumference of PTO seal assembly
- circlip is not exposed.

If telltale groove is visible, push PTO seal assembly rearwards to fully extend it.

If inner sleeve is not flush, gently tap it until it is flush.

Reposition rubber protector.

Reconnect EGTS sensor.

Install jet pump. Refer to *JET PUMP*.

Check engine oil level. Refill as necessary.

Run watercraft then ensure there is no oil leak in PTO seal area.

## BOOT

### Inspection

Inspect the condition of boot. If there is any damage or evidence of wear, replace it.

### Removal

Remove drive shaft. Refer to *DRIVE SHAFT* in this section.

Loosen gear clamp holding boot, then carefully pull boot and carbon ring from hull insert.

### Installation

The installation is the reverse of the removal procedure.

## CARBON RING

### Removal

Remove drive shaft. Refer to *DRIVE SHAFT* in this section.

Loosen gear clamp then pull carbon ring from boot.

### Installation

The installation is the reverse of the removal procedure.

# REVERSE SYSTEM

## SERVICE PRODUCTS

<b>Description</b>	<b>Part Number</b>	<b>Page</b>
Loctite 243 (blue).....	293 800 060 .....	291
Loctite 5150 (silicone sealant).....	293 800 086 .....	290
XP-S synthetic grease.....	293 550 010 .....	289



**Section 07 PROPULSION**  
**Subsection 03 (REVERSE SYSTEM)**

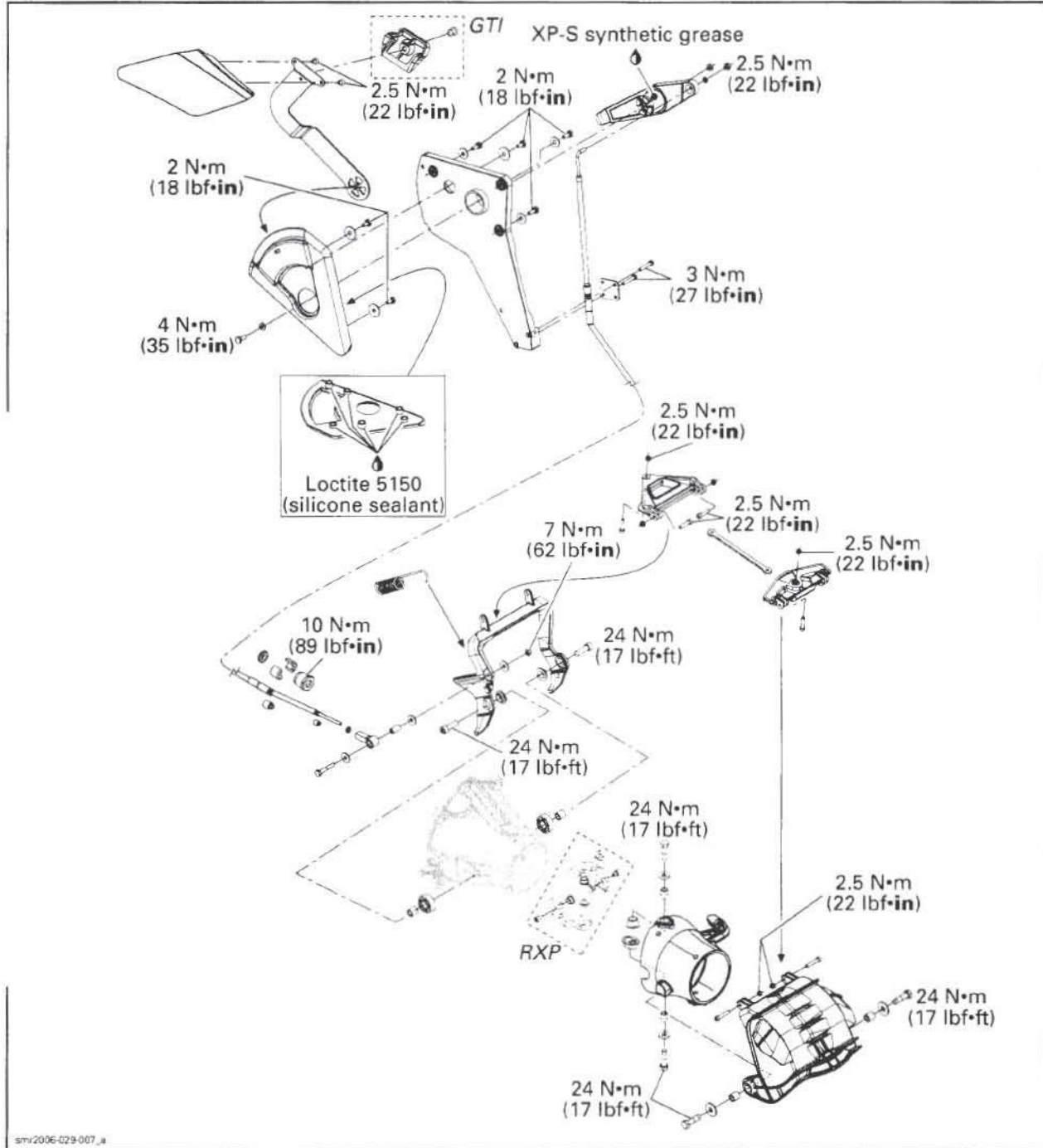

## GENERAL

During assembly/installation, use torque values and service products as in the exploded view.

Clean threads before applying a threadlocker. Refer to *SELF-LOCKING FASTENERS* and *LOCTITE APPLICATION* at the beginning of this manual for complete procedure.

### **⚠ WARNING**

Torque wrench tightening specifications must strictly adhered to.

Locking devices (e.g.: locking tabs, elastic stop nuts, self-locking fasteners, cotter pins, etc.) must be installed or replaced with new ones where specified. If the efficiency of a locking device is impaired, it must be renewed.

## PROCEDURES

### REVERSE CABLE

#### Removal

Unscrew bolt, washers and the elastic stop nut retaining reverse cable on pivot arm.

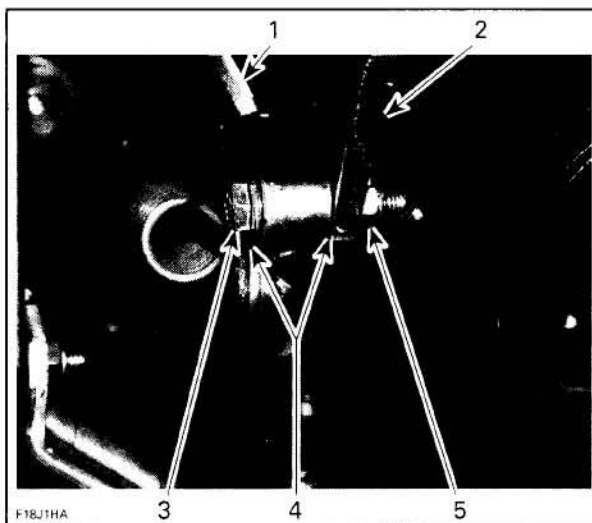

1. Reverse cable
2. Pivot arm
3. Bolt
4. Washer
5. Elastic stop nut

Unscrew the cable lock then remove the half rings.

#### **RXP Models**

Open storage compartment and remove basket.

Remove nut of front vent tube, unsnap wiring harness and separate vent tube.

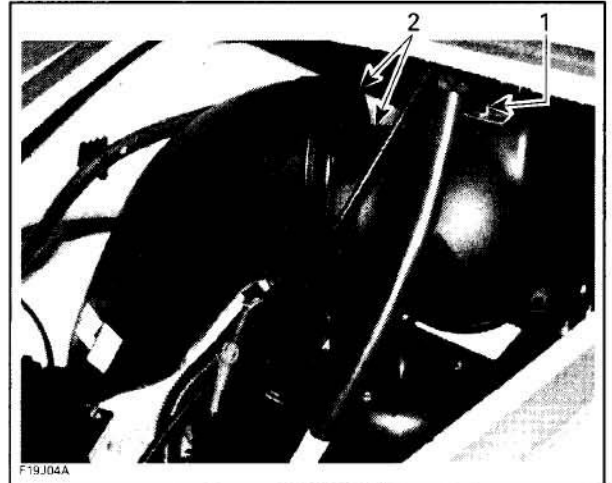

1. Remove nut
2. Separate bottom and top parts

Pull out bottom part first then top part.

#### **GTX and RXT Series**

Remove the seat and the glove box. Refer to *HULL AND BODY*.

Push the vent tube toward the front of the vehicle to get greater access to the reverse cable lever and the reverse cable support.

To release the vent tube, press down its locking tabs and move the tube.

There are two locking tabs; one above and one underneath the hose.

**DO NOT REMOVE** the vent tube completely.



**Section 07 PROPULSION**  
**Subsection 03 (REVERSE SYSTEM)**

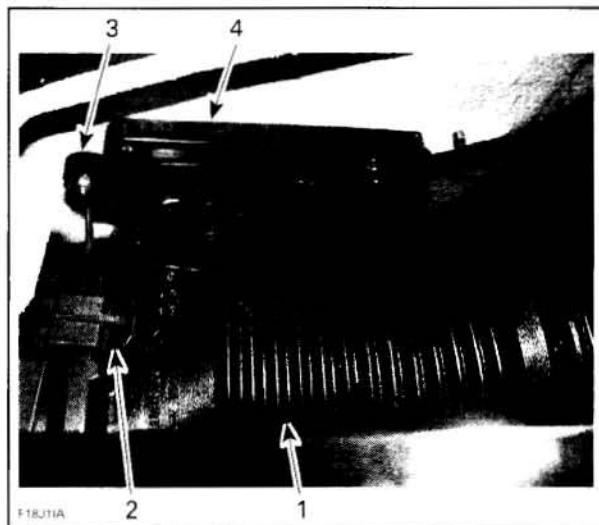

**TYPICAL**  
 1. Engine vent tube  
 2. Vent tube locking tab  
 3. Reverse cable lever  
 4. Reverse cable support

**GTI Series**

Remove glove box. Refer to *HULL AND BODY*.

**All Models**

On the reverse cable lever, unscrew the elastic stop nut and the washer retaining the reverse cable.

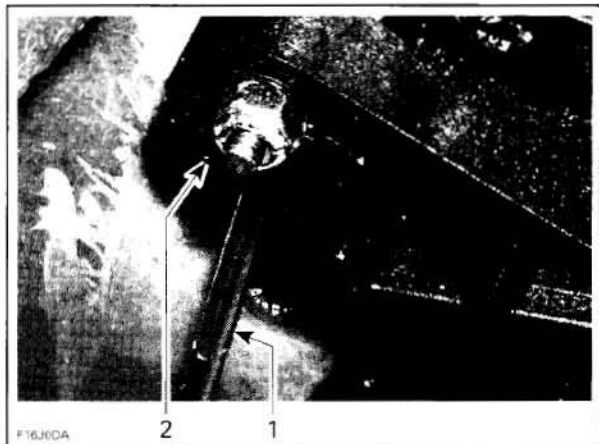

**TYPICAL**  
 1. Reverse cable  
 2. Reverse cable lever

Remove the bracket securing reverse cable at the bottom of reverse cable support.

**NOTE:** Before removing reverse cable from hull, note cable routing for reinstallation.

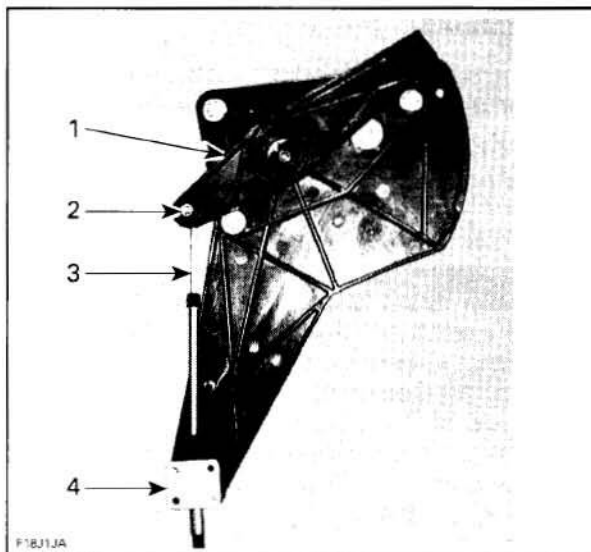

**TYPICAL**  
 1. Reverse cable lever  
 2. Elastic stop nut and washer  
 3. Reverse cable  
 4. Bracket

**Installation**

The installation is the reverse of the removal procedure.

**NOTE:** Adjust cable.

**Adjustment**

Put shift lever in forward position.

**⚠ WARNING**

When adjusting reverse cable, make sure lever is well engaged into the spring slot.

Place reverse gate in the up position.

Turn the joint at the end of reverse cable and align its hole with hole in pivot arm.

Secure with bolt, washers, spacer and elastic stop nut. Torque to 7 N•m (62 lbf•in).

**REVERSE CABLE LEVER**

**Removal**

Detach the reverse cable from reverse cable lever.

**Section 07 PROPULSION**  
Subsection 03 (REVERSE SYSTEM)

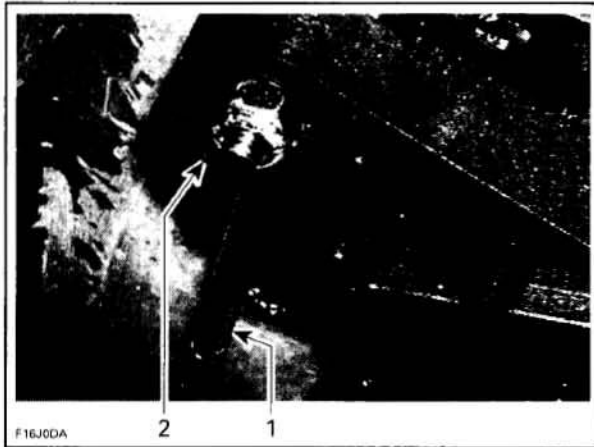

**TYPICAL**  
1. Reverse cable  
2. Reverse cable lever

Unscrew the shift lever retaining bolt, washer and nut, then remove reverse cable lever.

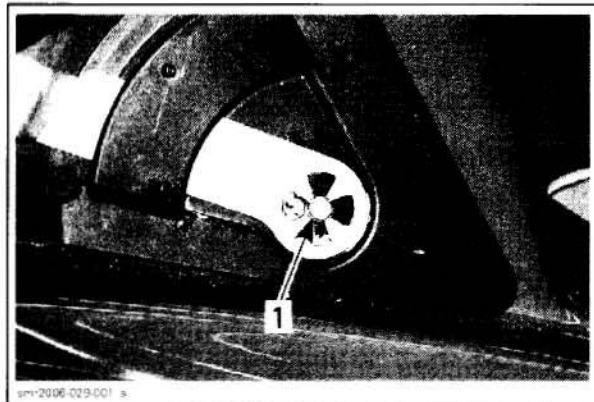

1. Shift lever retaining bolt

### Inspection

Check reverse cable lever for cracks or wear. Replace as required.

### Installation

Apply XP-S synthetic grease (P/N 293 550 010) on the reverse cable lever pivot and in the reverse cable support hole.

Install the reverse cable lever in a rotating movement. Engage properly the reverse cable lever tabs in the shift lever slots.

Insert reverse cable lever into reverse cable support slider and make sure that the lever slides freely in the support.

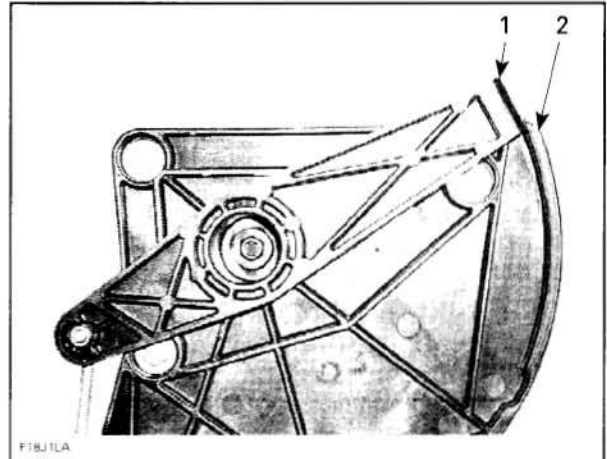

**TYPICAL**  
1. Reverse cable lever  
2. Reverse cable support slider

Make sure the shift lever action is smooth and precise. Forward and reverse positions should be easy to select with a decent position between each.

## SHIFT LEVER

### Removal

Remove shift lever handle.

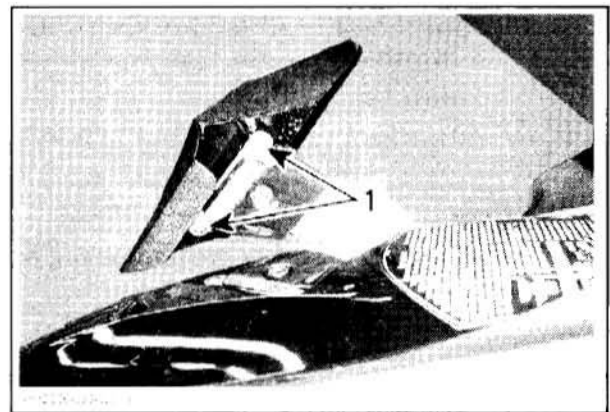

**TYPICAL**  
1. Shift lever handle screws

Unscrew the shift lever retaining bolt, washer and nut.



**Section 07 PROPULSION**  
**Subsection 03 (REVERSE SYSTEM)**

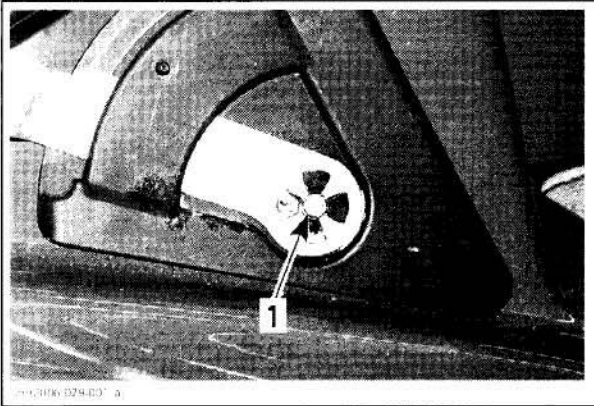

1. Shift lever retaining bolt

Disengage the shift lever slots from reverse cable lever tabs, then remove the shift lever.

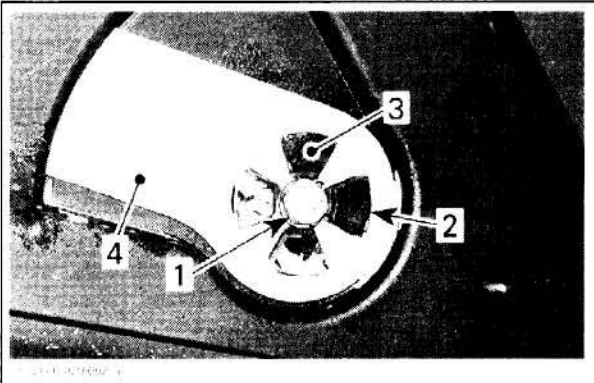

**TYPICAL**  
 1. Shift lever retaining bolt  
 2. Shift lever slot  
 3. Reverse cable lever tab  
 4. Shift lever

**Inspection**

Check shift lever for cracks or wear. Replace as required.

**Installation**

The installation is the reverse of the removal procedure.

**REVERSE CABLE SUPPORT**

**Removal**

Remove shift lever and reverse cable lever. See procedures above.

At the bottom of reverse cable support, remove the bracket securing reverse cable to its support.

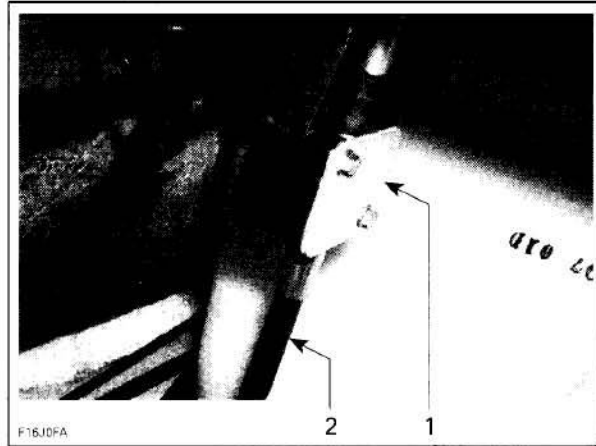

**TYPICAL**  
 1. Bracket  
 2. Reverse cable

Unscrew all bolts securing reverse cable support then remove it.

**Inspection**

Check the reverse cable support for cracks or wear. Replace as required.

**Installation**

The installation is the reverse of the removal procedure.

**SHIFT LEVER HOUSING**

**Removal**

Remove shift lever, reverse cable lever and reverse cable support. See procedures above.

Unscrew all bolts securing shift lever housing and remove it.

**Installation**

The installation is the reverse of the removal procedure. However, pay attention to the following.

Apply Loctite 5150 (silicone sealant) (P/N 293 800 086) around screws locations on shift lever housing as indicated by the shaded areas in the next illustration.

**Section 07 PROPULSION**  
**Subsection 03 (REVERSE SYSTEM)**

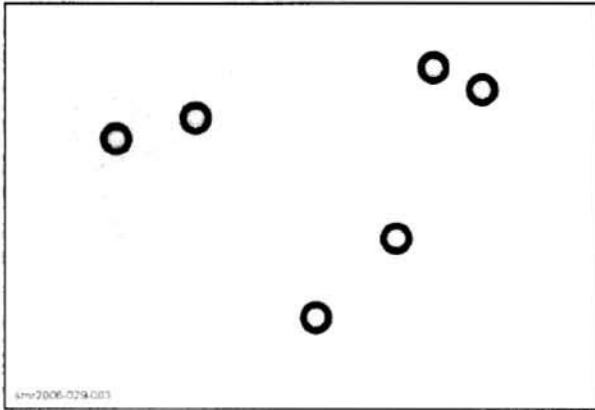

When installing shift lever housing, apply Loctite 243 (blue) (P/N 293 800 060) on threads of screws.

**REVERSE GATE**

**Removal**

To remove reverse gate, put shift lever in reverse position.

Unscrew pivot bolt.

Remove both reverse gate screws.

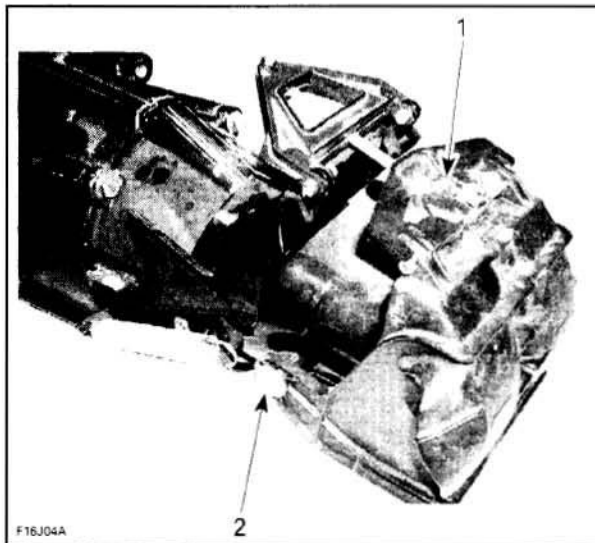

1 Pivot bolt  
 2 Reverse gate screw

**Installation**

Install reverse gate with spacer and washer. Torque to 20 N•m (15 lbf•ft).

**PIVOT SUPPORT**

**Removal**

Unscrew pivot support bolts.

Remove pivot bolt that attach link rod to pivot support.

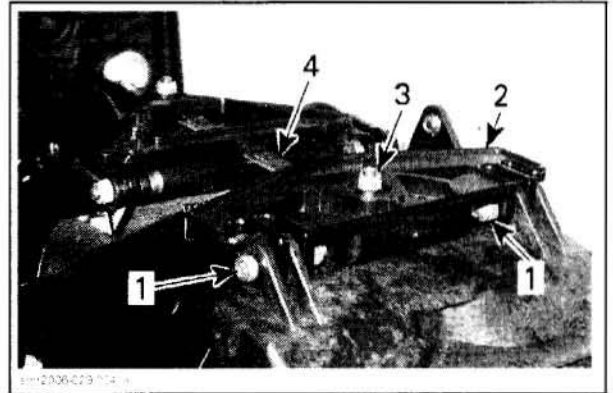

1 Pivot support bolts  
 2 Pivot support  
 3 Pivot bolt  
 4 Link rod

Withdraw pivot support.

**Installation**

The installation is the reverse of the removal procedure.

**LINK ROD**

**Removal**

Unscrew both pivot bolts and remove link rod.

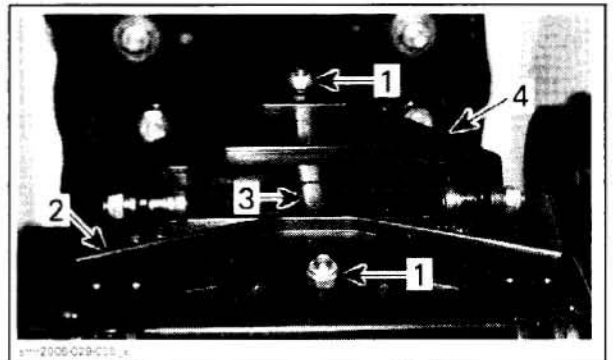

TYPICAL  
 1 Pivot bolts  
 2 Pivot support  
 3 Link rod  
 4 Pivot triangle

**Installation**

The installation is the reverse of the removal procedure.



## PIVOT TRIANGLE

### Removal

Remove link rod.

Unscrew pivot triangle bolts and remove pivot triangle.

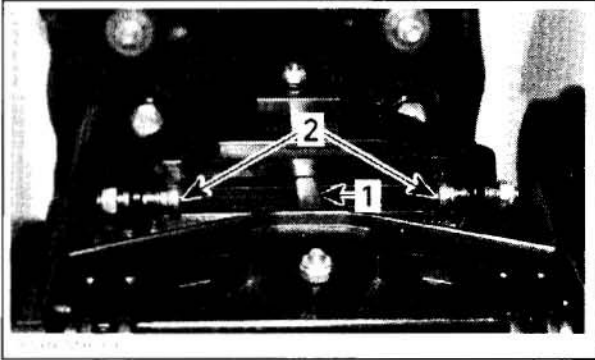

TYPICAL  
1 Link rod  
2 Pivot triangle bolts

### Installation

For installation, reverse the removal procedure.

### Installation

Install head bolts toward inside.

**NOTE:** Make sure the pivot triangle moves freely.

## PIVOT ARM

### Removal

Remove reverse gate. Refer to *REVERSE GATE*.

Position shift lever in forward.

On left side, remove the reverse cable, spring and pivot arm bolt.

On right side, remove steering cable and pivot arm bolt.

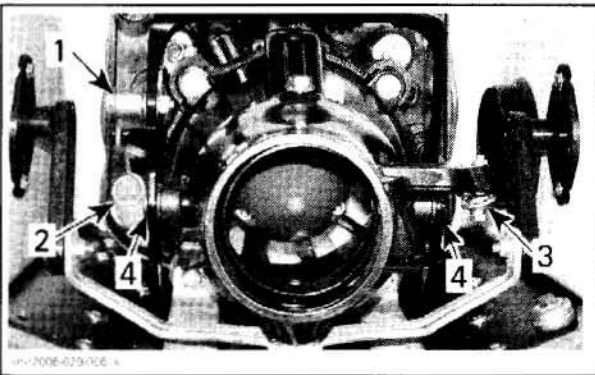

1 Reverse cable  
2 Spring  
3 Steering cable  
4 Pivot arm bolts

Withdraw pivot arm.

# VARIABLE TRIM SYSTEM

## SERVICE TOOLS

<b>Description</b>	<b>Part Number</b>	<b>Page</b>
multimeter FLUKE 111 .....	529 035 868 .....	295
VTS socket tool.....	295 000 133 .....	296-297

## SERVICE PRODUCTS

<b>Description</b>	<b>Part Number</b>	<b>Page</b>
Loctite 243 (blue).....	293 800 060 .....	297
Loctite Primer N .....	293 800 041 .....	297
XP-S synthetic grease.....	293 550 010 .....	297



# Section 07 PROPULSION

## Subsection 04 (VARIABLE TRIM SYSTEM)

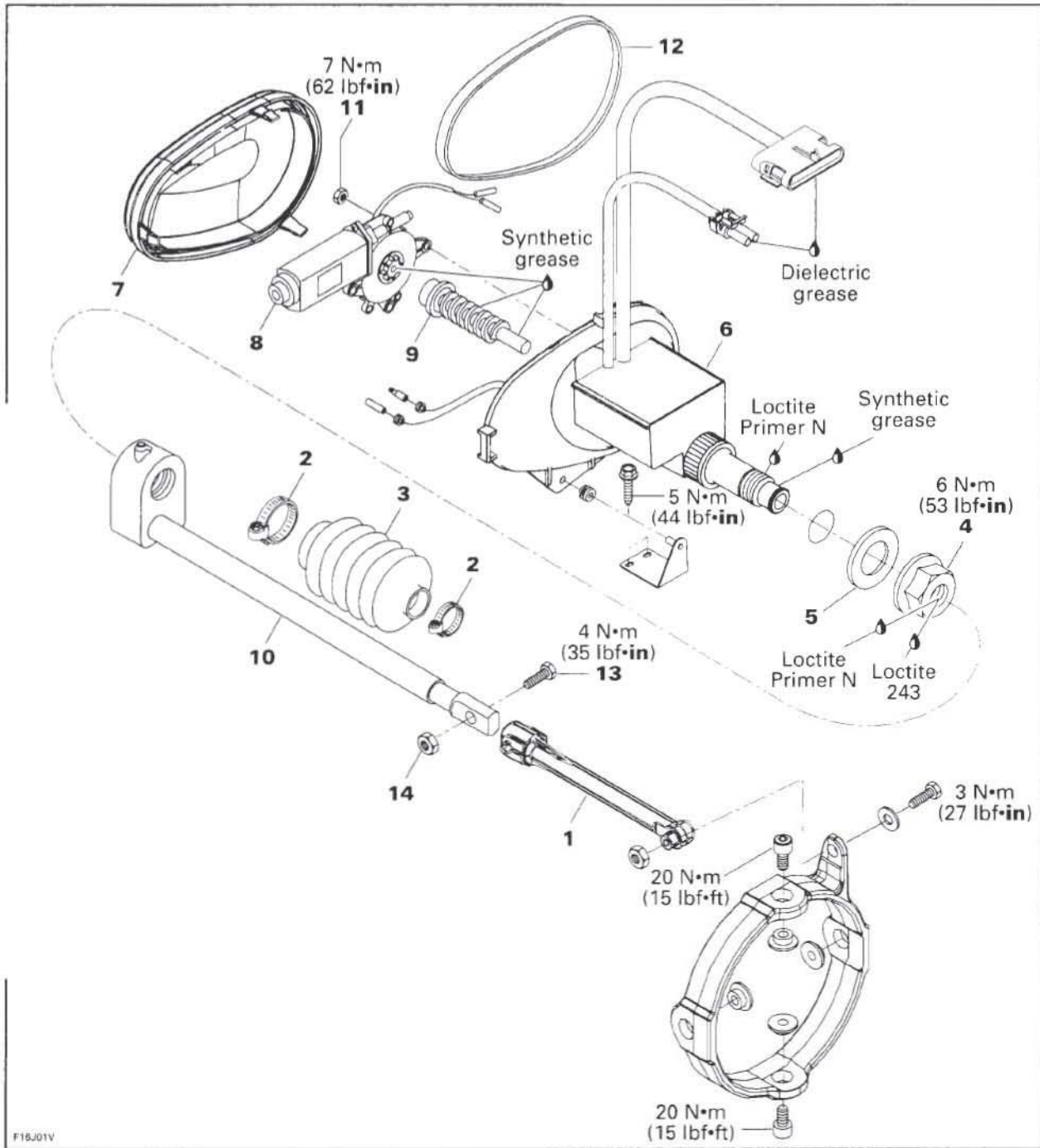

F16J01V

## Section 07 PROPULSION

### Subsection 04 (VARIABLE TRIM SYSTEM)

## GENERAL

During assembly/installation, use torque values and service products as in the exploded view.

Clean threads before applying a threadlocker. Refer to *SELF-LOCKING FASTENERS* and *LOCTITE APPLICATION* at the beginning of this manual for complete procedure.

### WARNING

Torque wrench tightening specifications must strictly adhered to.

Locking devices (e.g.: locking tabs, elastic stop nuts, self-locking fasteners, cotter pins, etc.) must be installed or replaced with new ones where specified. If the efficiency of a locking device is impaired, it must be renewed.

## TEST

### SWITCH

Always confirm first that the fuse is in good condition.

Disconnect BLACK wire, BLUE/WHITE wire and GREEN/WHITE wire of VTS switch.

Using the multimeter FLUKE 111 (P/N 529 035 868), connect test probes to switch BLACK and BLUE/WHITE wires; then, connect test probes to switch BLACK and GREEN/WHITE wires.

Measure resistance; in both test it should be high when button is released and must be close to zero when activated.

### MOTOR

Always confirm first that the fuse is in good condition.

The fuse is located on the MPEM module.

Motor condition can be checked with the multimeter FLUKE 111 (P/N 529 035 868). Install test probes on both RED/PURPLE/WHITE and ground wires of the 2-circuit connector housing. Measure resistance, it should be close to 1.5 ohm.

If motor seems to jam and it has not reached the end of its stroke, the following test could be performed.

First remove motor. Then manually rotate worm to verify VTS system actuating mechanism for free operation.

Connect motor through a 15 A fuse directly to the battery.

Connect wires one way then reverse polarities to verify motor rotation in both ways.

If VTS actuating mechanism is correct and the motor turns freely in both ways, VTS module could be defective.

If VTS motor does not stop at the end of its stroke while installed, the motor could be defective.

## CONTROL MODULE

It receives its current from the battery. It is protected by its own fuse located on the MPEM module.

### Resistance Test

Disconnect BROWN/BLACK wire and BROWN/WHITE wire of VTS control module.



Connect test probes of a multimeter to BROWN/BLACK wire and BROWN/WHITE wire of VTS control module.

Push on VTS switch down position until motor stops.

Read the resistance on the ohmmeter, it should indicate a resistance of 24 ohms  $\pm$  1%.

Push on VTS switch up position until motor stops.

Read the resistance on the ohmmeter, it should indicate a resistance of 167 ohms  $\pm$  1%.

RESISTANCE ( $\Omega$ )	NOZZLE POSITION
167 $\pm$ 1%	UP
	
24 $\pm$ 1%	DOWN

**NOTE:** If the VTS control module passes this resistance test, it does not mean it is in perfect condition.

## PROCEDURES

### CONTROL MODULE AND MOTOR

#### Removal

Remove seat and engine cover to have access to VTS module.

Remove nut **no. 14** and bolt **no. 13** retaining VTS rod **no. 1** to sliding shaft **no. 10**.

Remove clamps **no. 2**.

Remove rubber boot **no. 3**.



## Section 07 PROPULSION

### Subsection 04 (VARIABLE TRIM SYSTEM)

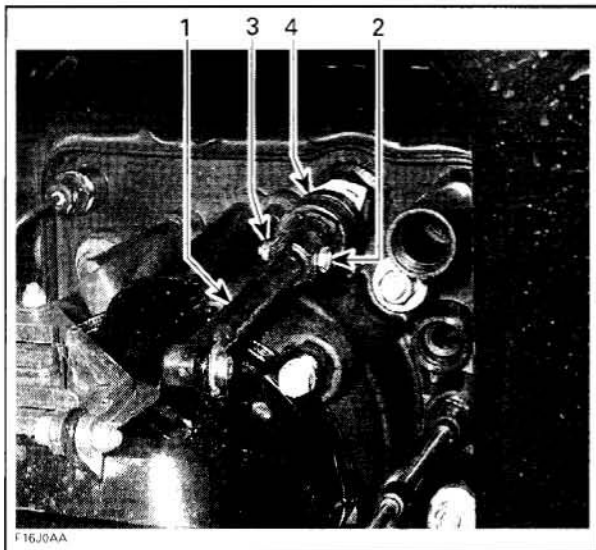

1. VTS rod
2. Bolt
3. Stop nut
4. Rubber boot

To loosen nut no. 4, use the VTS socket tool (P/N 295 000 133).

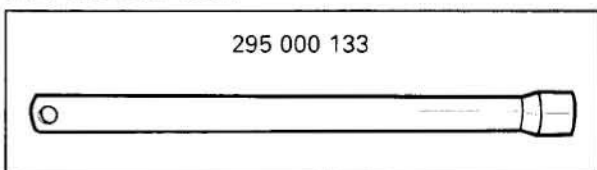

Remove sealing washer no. 5.  
Disconnect wiring harnesses.  
Pull out VTS assembly no. 6 from bilge.

#### Disassembly

##### Cover

Remove VTS cover no. 7 by pressing on tabs.

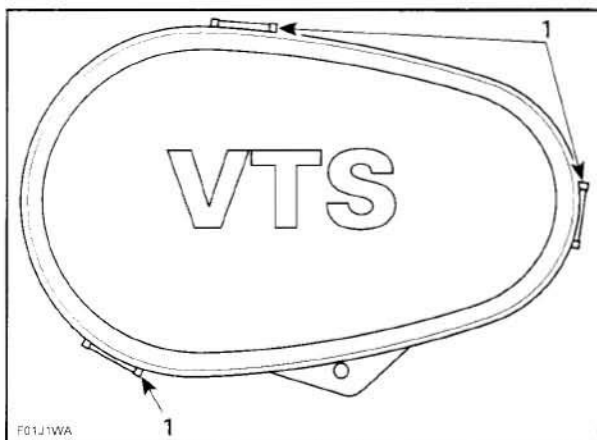

1. Press tabs to remove cover

##### Motor

Disconnect wires from motor no. 8.  
Remove retaining nuts no. 11.

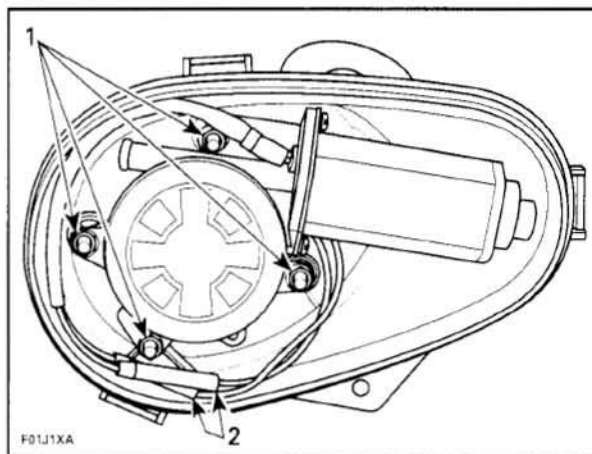

1. Remove nuts
2. Disconnect wires

Pull on motor to remove it.

##### Worm and Sliding Shaft

Simply pull on worm no. 9 and sliding shaft no. 10 in order to remove them.

#### Inspection

##### Rubber Boot

Make sure rubber boot no. 3 is in good condition. If it is cracked or torn, replace boot.

##### Worm

Inspect threads and splines of worm no. 9 for wear. If worm replacement is necessary, renew also sliding shaft.

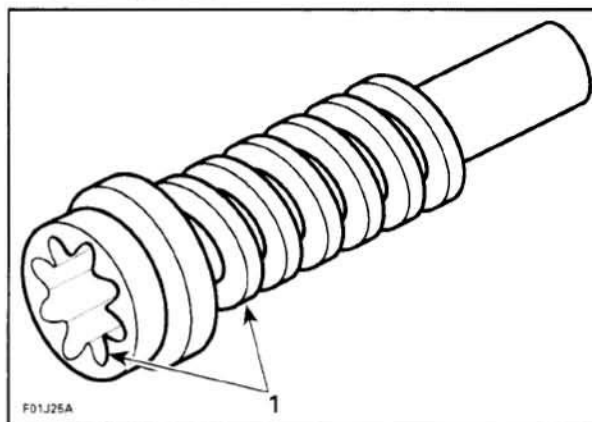

1. Inspect threads and splines

## Section 07 PROPULSION

### Subsection 04 (VARIABLE TRIM SYSTEM)

#### Assembly

Assembly is essentially the reverse of disassembly procedures. However pay particular attention to the following.

#### Motor, Worm and Sliding Shaft

Apply XP-S synthetic grease (P/N 293 550 010) to worm.

Screw worm **no. 9** to sliding shaft **no. 10**.

Mesh worm splines to gear of motor.

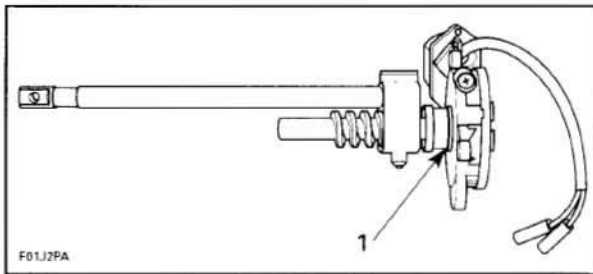

1. Mesh worm spline to gear of motor

Install motor **no. 8**, worm and sliding shaft in VTS housing.

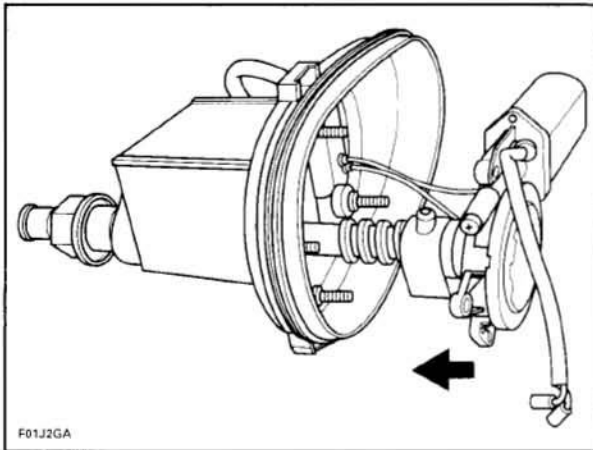

Tighten nuts **no. 11** to 7 N•m (62 lbf•in).

Connect wires of motor.

**CAUTION:** Make sure wire color codes match.

Install cover **no. 7**.

**NOTE:** Make sure seal **no. 12** is in place.

#### Installation

Installation is essentially the reverse of removal procedures. However pay particular attention to the following.

#### Nut and Sealing Washer

Place sealing washer **no. 5** on nut **no. 4**. Make sure seal lips are facing toward hull.

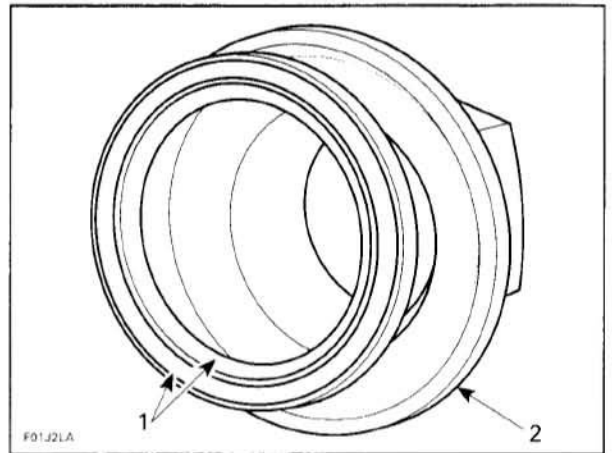

1. Seal lips facing hull  
2. Nut

Apply Loctite Primer N (P/N 293 800 041) to threads of VTS housing, and to nut **no. 4**.

Apply Loctite 243 (blue) (P/N 293 800 060) to nut **no. 4**.

Install nut with sealing washer and torque to 7 N•m (62 lbf•in) using the VTS socket tool (P/N 295 000 133).

#### Sliding Shaft and Rubber Boot

Apply XP-S synthetic grease (P/N 293 550 010) to sliding shaft.

Install rubber boot **no. 3**, over sliding shaft and secure with clamps.

#### VTS Rod

Secure the VTS rod onto the sliding shaft end using bolt **no. 13** and nut **no. 14**. Torque nut to 4 N•m (35 lbf•in).

#### Adjustment

No adjustment is required.



# STEERING SYSTEM

## SERVICE TOOLS

<b>Description</b>	<b>Part Number</b>	<b>Page</b>
safety lanyard switch tool.....	529 035 943 .....	304
steering cable tool .....	295 000 145 .....	310

## SERVICE PRODUCTS

<b>Description</b>	<b>Part Number</b>	<b>Page</b>
Loctite 243 (blue).....	293 800 060 .....	302-303, 307-309
Loctite 271 (red) .....	293 800 005 .....	304, 309
Loctite 767 (antiseize lubricant) .....	293 800 070 .....	309
XP-S synthetic grease.....	293 550 010 .....	308

**Section 08 STEERING SYSTEM**  
 Subsection 01 (STEERING SYSTEM)

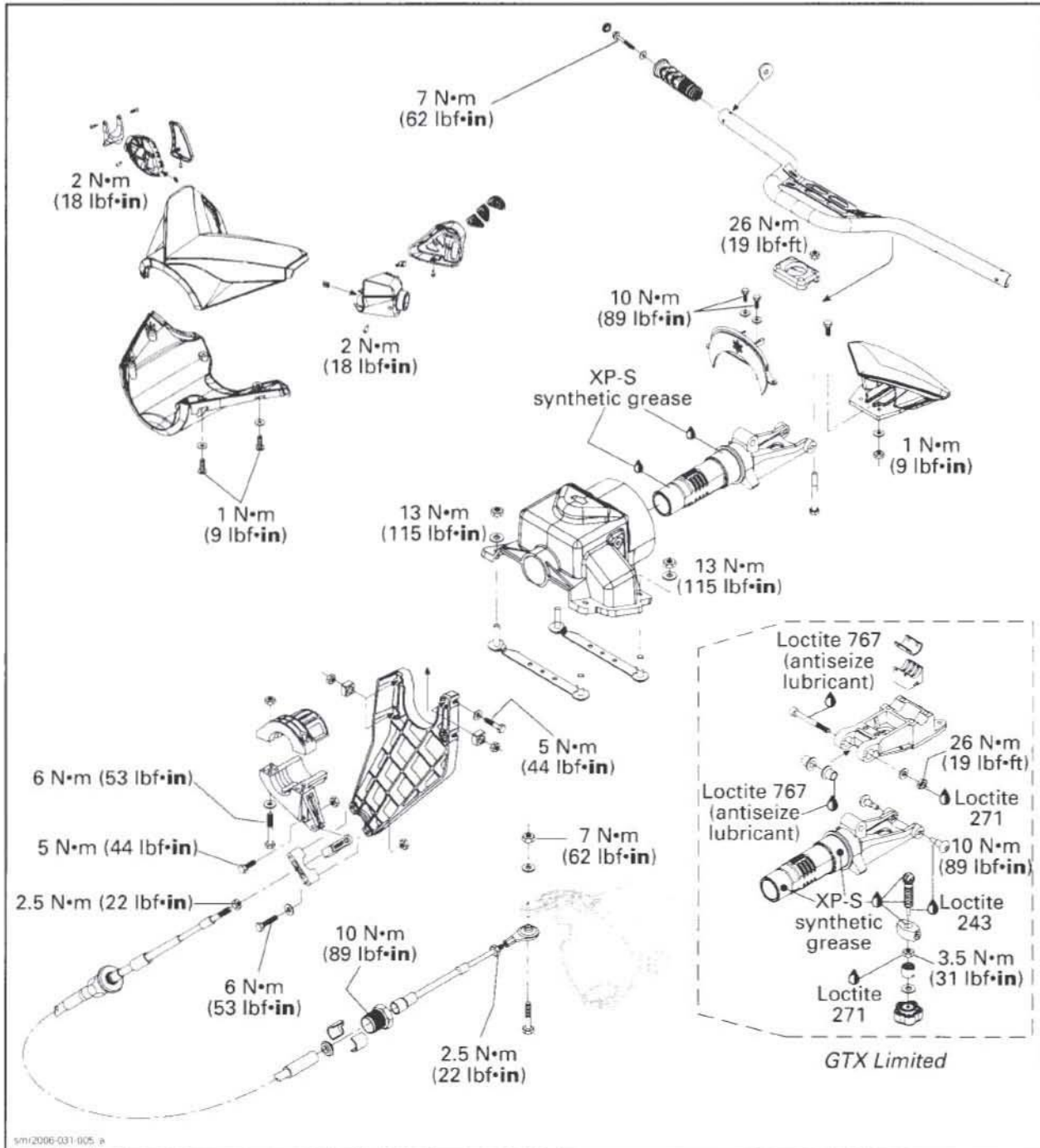



**Section 08 STEERING SYSTEM**  
Subsection 01 (STEERING SYSTEM)

**CAUTION:** Verify when the handlebar is turned completely to the left or right side, that there is no interference with venturi, O.P.A.S. or VTS ring.

**PROCEDURES**

**NOZZLE**

**Removal**

Remove O.P.A.S. "U" lever screws and pull out lever.

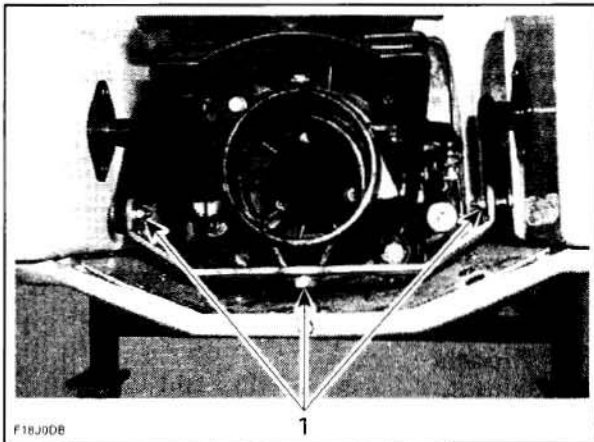

TYPICAL  
1. "U" lever screws

Remove reverse gate. Refer to *REVERSE GATE*.  
Disconnect steering cable from jet pump nozzle.

**RXP Models**

Disconnect VTS link rod.

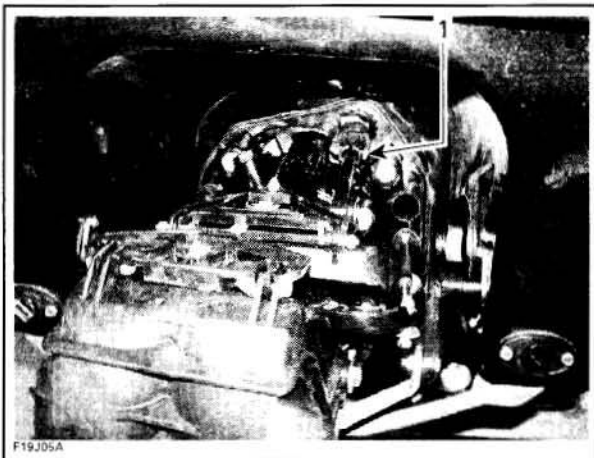

1. Link rod

On both sides, remove screws holding VTS ring to nozzle.

Pull out nozzle and VTS ring.

**Other Models**

Remove retaining screws, sleeves and washers on top and underneath nozzle.

Remove nozzle.

**Installation**

The installation is the reverse of the removal procedure. However, pay attention to the following.

Apply Loctite 243 (blue) (P/N 293 800 060) on screw threads (or use new self-locking screws).

**HANDLEBAR GRIP**

**Removal**

To remove handlebar grip, pull out cap and remove screw.

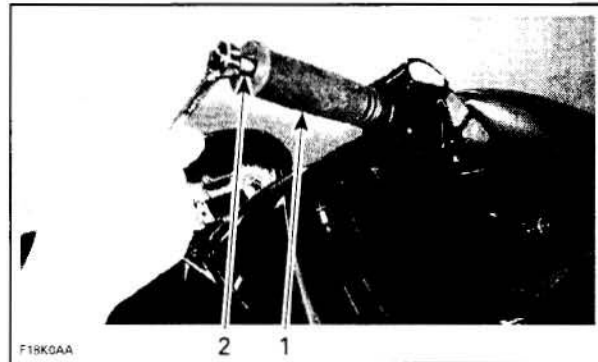

1. Handlebar grip  
2. Handlebar grip screw

Pull out handlebar grip and remove grip insert from handlebar.

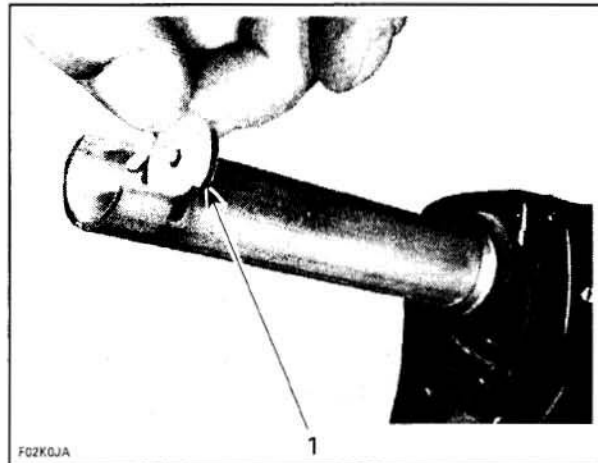

1. Grip insert

**NOTE:** Verify grip insert for damage.

**Section 08 STEERING SYSTEM**  
Subsection 01 (STEERING SYSTEM)

**Installation**

When installing the grip insert in the handlebar, ensure that it is properly inserted in the slot at the end of the handlebar tubing.

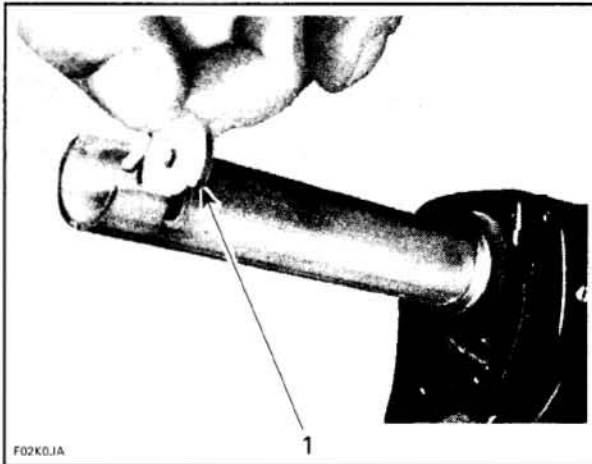

1. Grip insert

Install handlebar grip on handlebar matching it to the notch in the handlebar.

Install flat washer and handlebar grip screw. Apply Loctite 243 (blue) (P/N 293 800 060) on threads screw.

**CAUTION:** Ensure to install flat washer otherwise screw will damage grip end.

Torque handlebar grip screw to 7 N•m (62 lbf•in). Install cap.

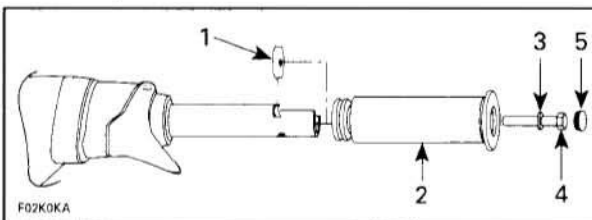

- 1. Grip insert
- 2. Grip
- 3. Flat washer
- 4. Screw
- 5. Cap

**STEERING COVER**

**Removal**

Remove handle grips.

Loosen screws of throttle handle housing and of multifunction switch housing.

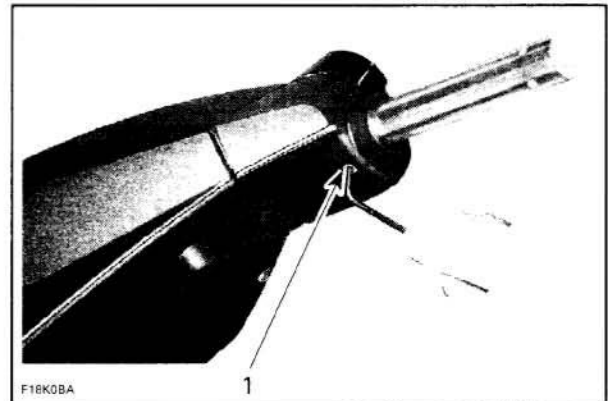

1. Screw

Remove tapping screws.

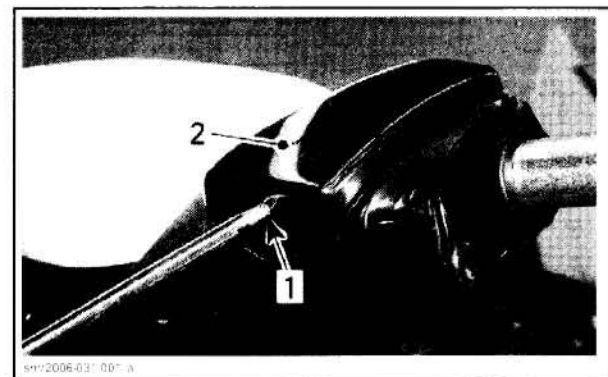

- 1. Tapping screw
- 2. Throttle handle housing

Remove throttle housing cover then the throttle handle housing.

Unhook throttle cable from throttle handle.

Pry out the throttle cable housing from throttle handle housing.

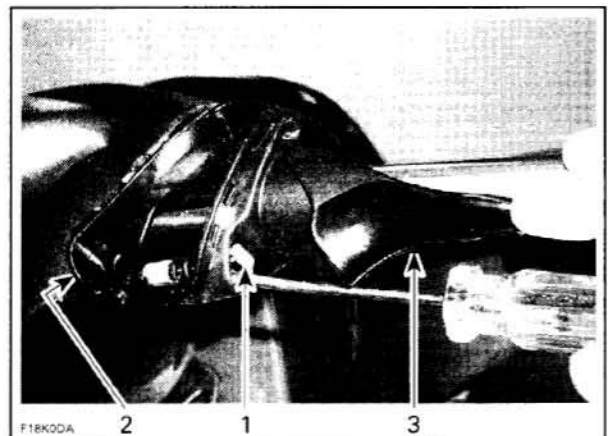

- 1. Throttle cable
- 2. Throttle handle housing
- 3. Throttle handle



## Section 08 STEERING SYSTEM

### Subsection 01 (STEERING SYSTEM)

Unplug and remove the multifunction switch housing.

Remove 6 screws and flat washers each side of steering cover.

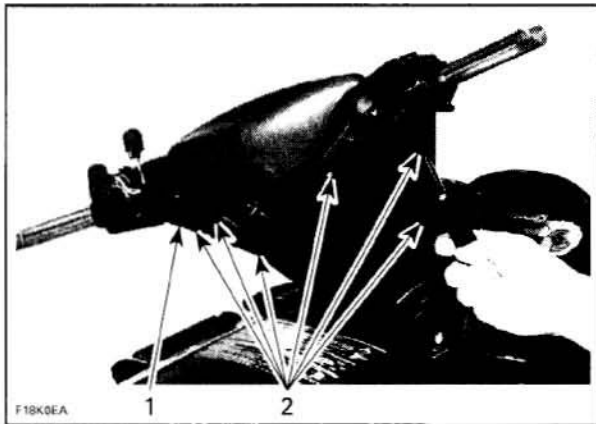

1. Steering cover  
2. Screws

#### GTX Limited Models

Set handlebar to its lowest position by turning adjustment knob counterclockwise.

While holding adjustment knob, turn support bushing clockwise.

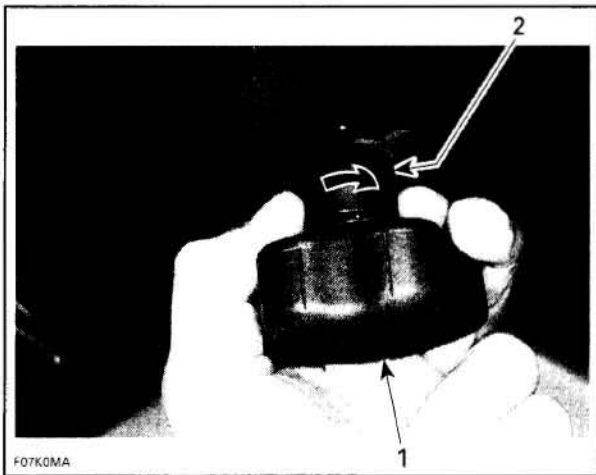

- TYPICAL  
1. Adjustment knob  
2. Support bushing

Hold jam nut and unscrew adjustment knob from adjuster screw.

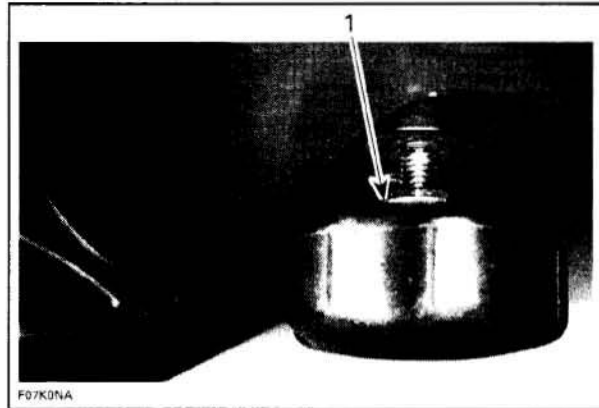

- TYPICAL  
1. Loosen jam nut

#### All Models

Remove lower steering cover.

Unscrew DESS switch nut using safety lanyard switch tool (P/N 529 035 943).

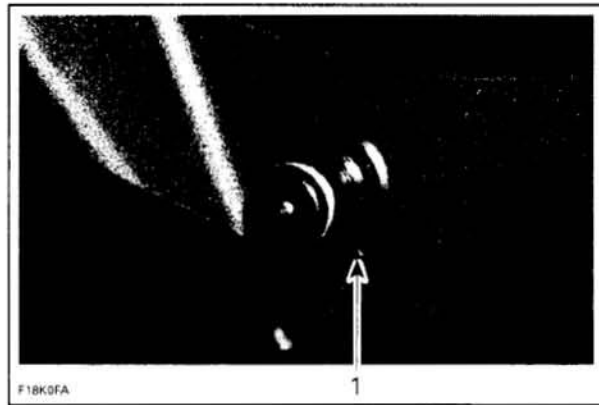

1. DESS switch nut

Remove upper steering cover.

#### Installation

For installation, reverse the removal procedure.

#### GTX Limited Model

Apply Loctite 271 (red) (P/N 293 800 005) on threads of jam nut.

## STEERING PADDING

### Removal

Remove steering cover as mentioned above.

Remove 2 screws, flat washers and nuts securing steering padding to steering stem.

**Section 08 STEERING SYSTEM**  
**Subsection 01 (STEERING SYSTEM)**

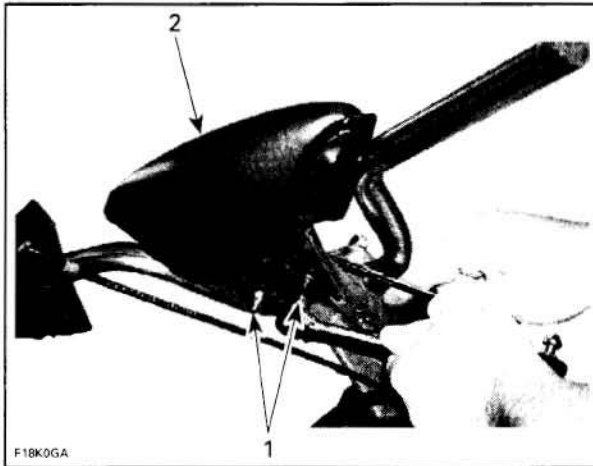

1. Screws  
 2. Steering padding

Remove steering padding.

**Installation**

The installation is the reverse of the removal procedure.

**HANDLEBAR**

**Removal**

Remove steering cover and steering padding as mentioned above.

Remove 4 elastic stop nuts retaining steering clamp. Discard elastic stop nuts.

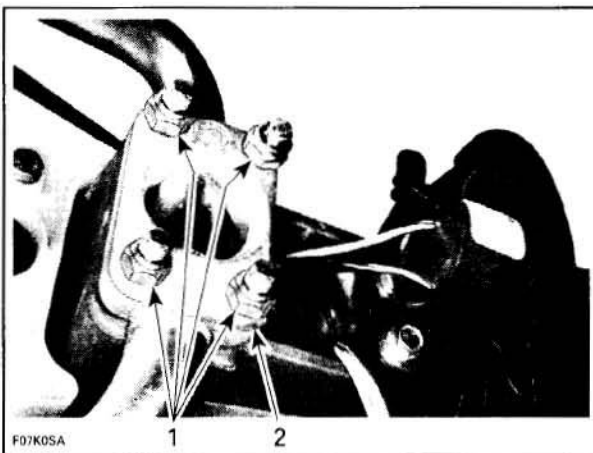

**TYPICAL**  
 1. Remove nuts  
 2. Steering clamp

Detach steering clamp and remove handlebar.  
 On **GTX Limited** models, withdraw rubber pad and stopper.

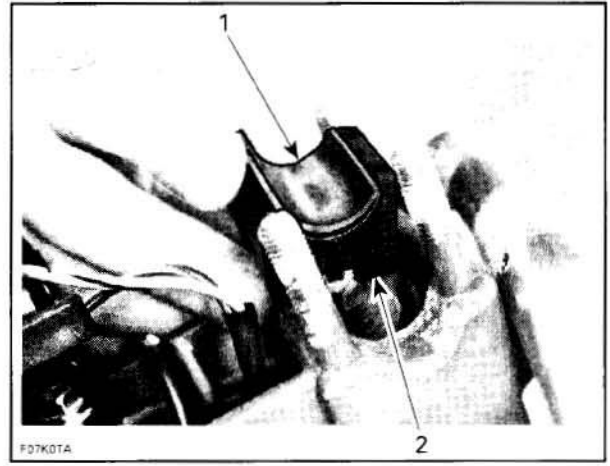

**TYPICAL**  
 1. Rubber pad  
 2. Stopper

**Installation**

**GTX Limited Models Only**

Before installing handlebar, position stopper and rubber pad.

**CAUTION:** Rubber pad must not exceed stopper.

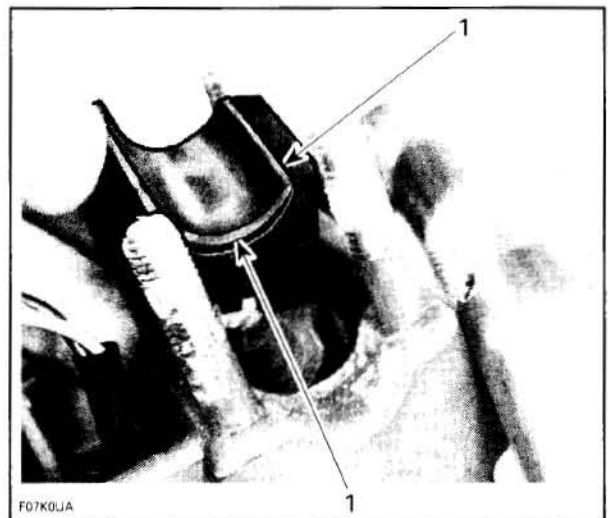

1. Pad must not exceed stopper

**All Models**

Position handlebar. Install steering clamp and secure with **NEW** elastic stop nuts.

Torque nuts to 26 N•m (19 lbf•ft) as per the following sequence.



**Section 08 STEERING SYSTEM**  
**Subsection 01 (STEERING SYSTEM)**

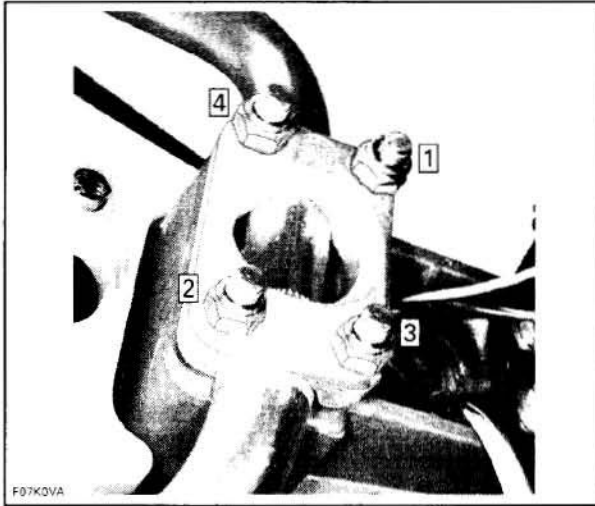

**STEERING CABLE SUPPORT**

**Removal**

**RXP Models**

Open front storage cover and remove basket.  
 Remove front vent tube.

**GTI Series**

Remove glove box and console. Refer to *BODY AND HULL*.

**GTX Series and RXT Models**

Open front storage cover and remove rear access panel.

**All Models**

Unscrew bolts securing retaining block then remove it from steering cable support.

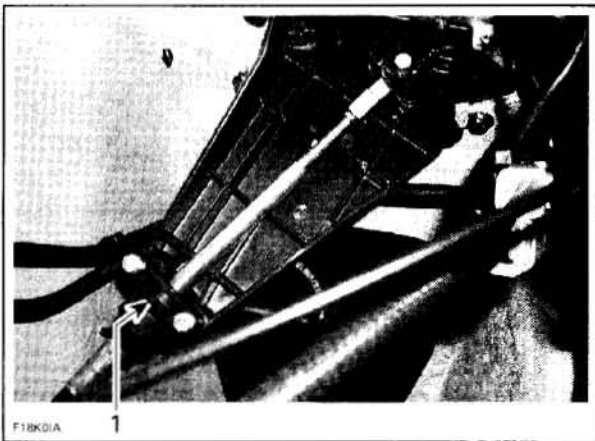

1. Retaining block

Loosen bolts each side of steering support.

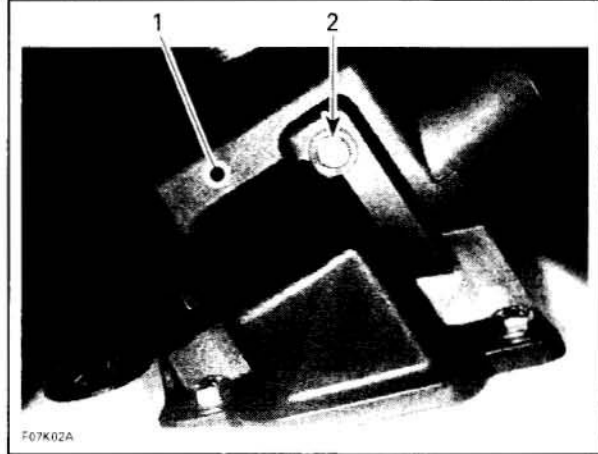

**RIGHT SIDE**  
 1. Steering support  
 2. Bolt

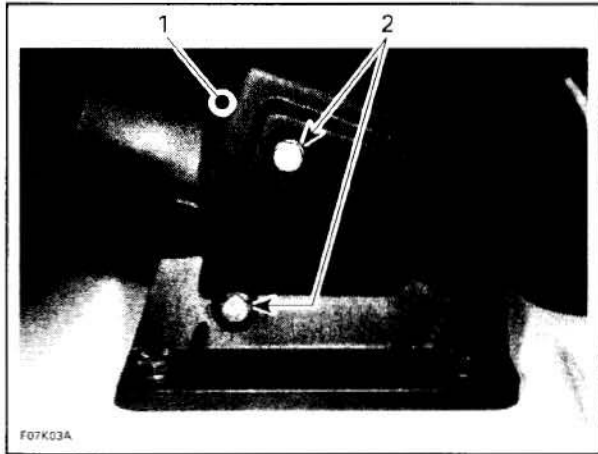

**LEFT SIDE**  
 1. Steering support  
 2. Bolts

Detach fuel lines from steering cable support.

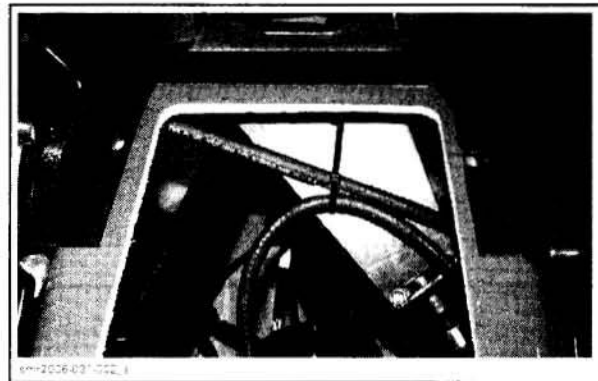

**GTI SE MODEL SHOWN**

Remove steering cable support.

**Section 08 STEERING SYSTEM**  
Subsection 01 (STEERING SYSTEM)

**Installation**

For installation, reverse the removal procedure.

Apply Loctite 243 (blue) (P/N 293 800 060) on threads of bolts before installing them.

**STEERING SUPPORT**

**Removal**

**GTI Series**

Remove console. Refer to *BODY AND HULL*.

**All Models except GTI Series**

Open front storage cover.

**All Models**

Cut locking tie securing wiring harness boot.



**TYPICAL**  
1. Boot  
2. Locking tie

Disconnect the throttle cable from throttle body.

Disconnect the wiring harnesses leading out of steering stem and cut locking tie.

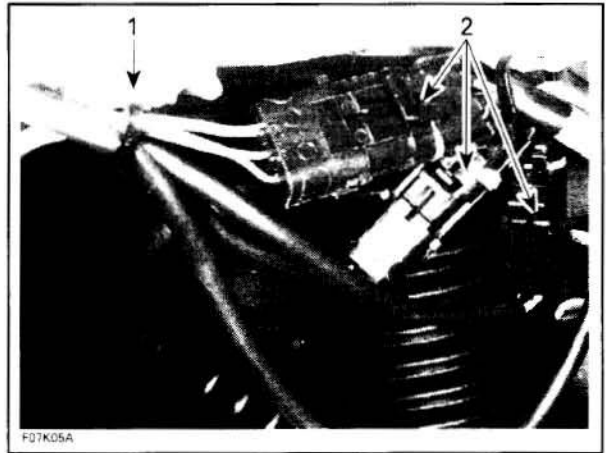

**TYPICAL**  
1. Tie rap  
2. Connectors

Disconnect the steering cable from the steering stem arm.

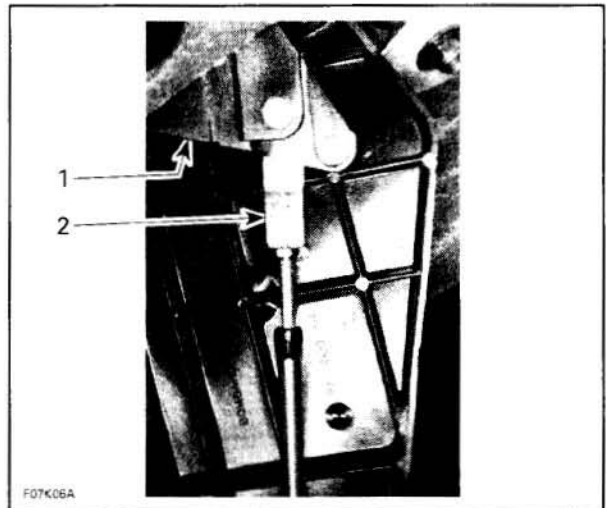

**TYPICAL**  
1. Steering stem arm  
2. Steering cable

Remove bolts retaining cable support to steering support.

Remove bolts and lock nuts from steering retaining strip studs.



## Section 08 STEERING SYSTEM

### Subsection 01 (STEERING SYSTEM)

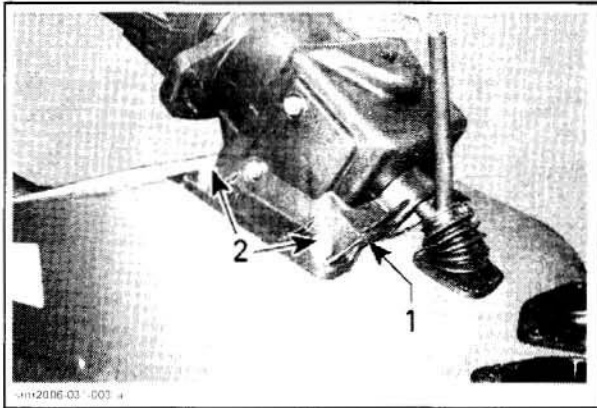

TYPICAL  
 1. Steering support  
 2. Retaining strip studs

Remove steering support with handlebar, wiring harnesses and cables.

### Installation

The installation is the reverse of the removal procedure.

Apply Loctite 243 (blue) (P/N 293 800 060) on threads of bolts before installing them.

## STEERING STEM

### Removal

Remove steering support. Refer to *STEERING SUPPORT* above.

Unscrew steering stem arm support bolts and discard elastic stop nuts.

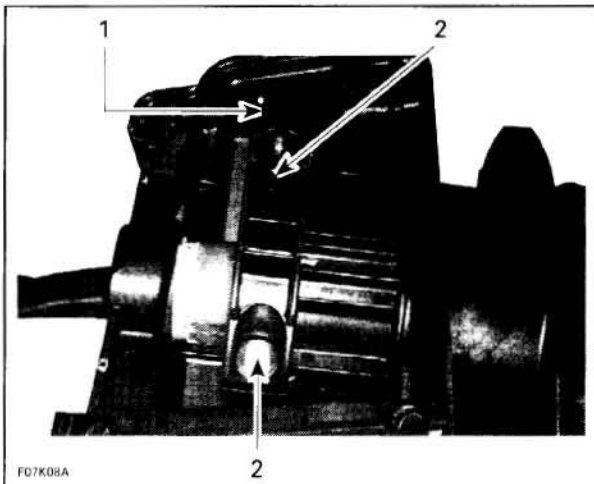

1. Steering stem arm  
 2. Steering stem arm support bolts

Pull steering stem out of steering support.

### Installation

Apply XP-S synthetic grease (P/N 293 550 010) on contact surfaces of steering stem before installing it into steering support.

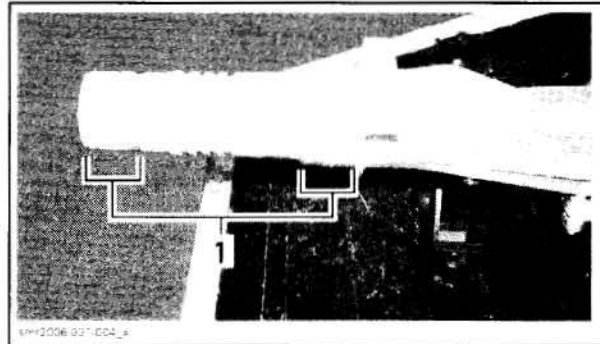

1. Apply grease here

Position steering stem arm onto steering stem.

### ⚠ WARNING

Make sure the integrated flat keys of the steering stem arm and support are properly seated in steering stem keyways. Steering stem arm must be locked in place before torquing the bolts.

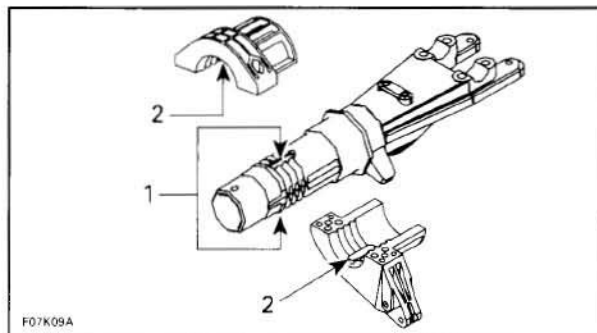

1. Keyways  
 2. Integrated flat key

Torque bolts of steering stem arm to 6 N•m (53 lbf•in). Install **NEW** elastic stop nuts.

Install all other removed parts.

## HANDLEBAR SUPPORT

### Removal

#### **GTX Limited Models**

Remove steering stem from vehicle. See procedure above.

Unscrew nut and remove pivot bolt retaining handlebar support to steering stem.

## Section 08 STEERING SYSTEM

### Subsection 01 (STEERING SYSTEM)

Unscrew threaded pivots to remove threaded block from steering stem.

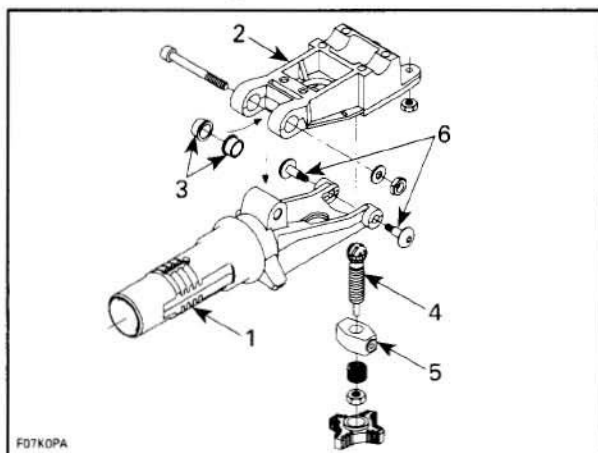

1. Steering stem
2. Handlebar support
3. Support bushing
4. Adjuster screw
5. Threaded block
6. Threaded pivots

### Installation

Apply Loctite 767 (antiseize lubricant) (P/N 293 800 070) then install support bushings on handlebar support.

Apply Loctite 767 (antiseize lubricant) (P/N 293 800 070) on pivot bolt.

**CAUTION:** Make sure antiseize lubricant does not come in contact with threads of bolt.

Apply Loctite 271 (red) (P/N 293 800 005) on threads of jam nut.

Apply Loctite 243 (blue) (P/N 293 800 060) in adjustment knob and on threaded pivots.

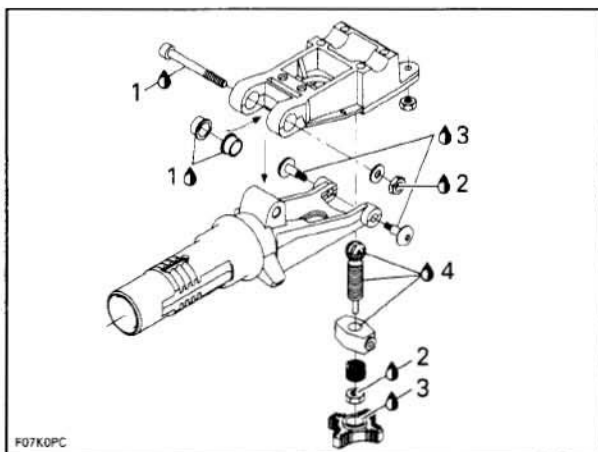

1. Loctite 767 (antiseize lubricant)
2. Loctite 271 (red)
3. Loctite 243 (blue)
4. XP-S synthetic grease

Install handlebar support to steering stem and secure with pivot bolt. Apply Loctite 271 (red) (P/N 293 800 005) on threads of nut then install nut and torque to 26 N•m (19 lbf•ft).

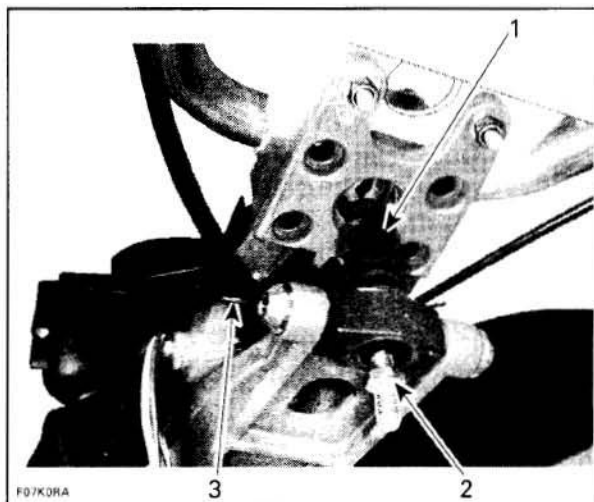

1. Adjuster screw
2. Apply Loctite 271 (red)
3. Locking tie

Ensure wire harness is properly secured to handlebar support with a locking tie.

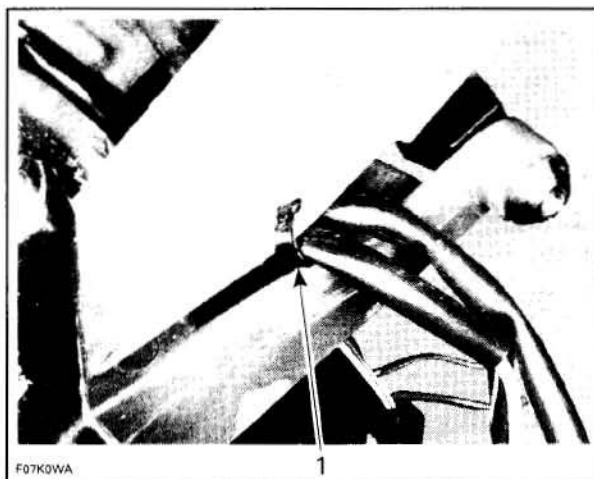

1. Locking tie holding harness to handlebar support

## STEERING CABLE

### Removal

Disconnect steering cable from steering stem arm.

Remove retaining block.

Disconnect ball joint from jet pump nozzle.

Remove ball joint and jam nut from cable.

Loosen nut retaining the steering cable to jet pump nozzle, then remove half rings and O-ring.



## Section 08 STEERING SYSTEM

### Subsection 01 (STEERING SYSTEM)

**NOTE:** To loosen nut, use the steering cable tool (P/N 295 000 145).

Remove steering cable from watercraft. Note routing for installation.

#### Installation

The installation is the reverse of the removal procedure. However, pay attention to the following.

The threaded portion of steering cable inserts into ball joint should have between 8 and 10 mm (5/16 and 25/64 in).

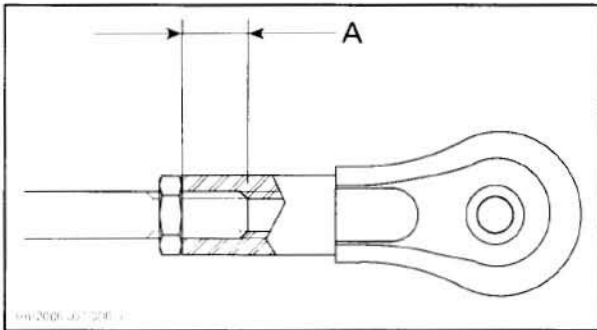

A. 8 to 10 mm (5/16 to 25/64 in)

Torque jam nut to 2.5 N•m (22 lbf•in).

Install cable and make sure its routing is same as the previous cable.

Torque retaining block screws on cable support to 6 N•m (53 lbf•in). Use **NEW** elastic stop nuts.

Secure the steering cable ball joint to the nozzle as per following illustration.

**CAUTION:** Ensure the ball joint is parallel ( $\pm 10^\circ$ ) to the nozzle arm.

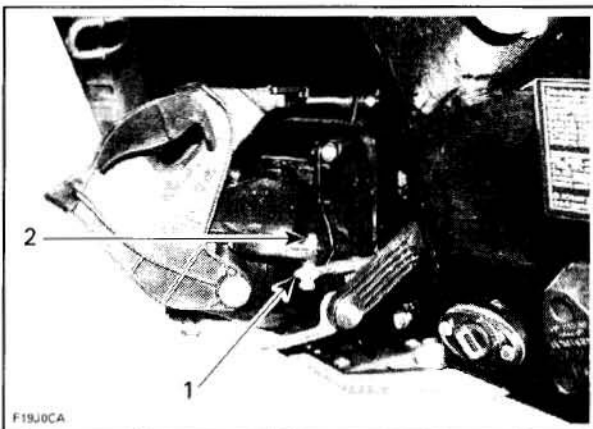

#### TYPICAL

1. Ball joint below steering arm
2. Torque nut to 7 N•m (62 lbf•in)

Check steering alignment.

# OFF-POWER ASSISTED STEERING (O.P.A.S.)

## SERVICE TOOLS

<u>Description</u>	<u>Part Number</u>	<u>Page</u>
O.P.A.S. cylinder nut wrench .....	529 035 840 .....	315, 317, 319

## SERVICE PRODUCTS

<u>Description</u>	<u>Part Number</u>	<u>Page</u>
Loctite 5150 (silicone sealant) .....	293 800 086 .....	320



# Section 08 STEERING SYSTEM

## Subsection 02 (OFF-POWER ASSISTED STEERING (O.P.A.S.))

### GTX and RXT Series

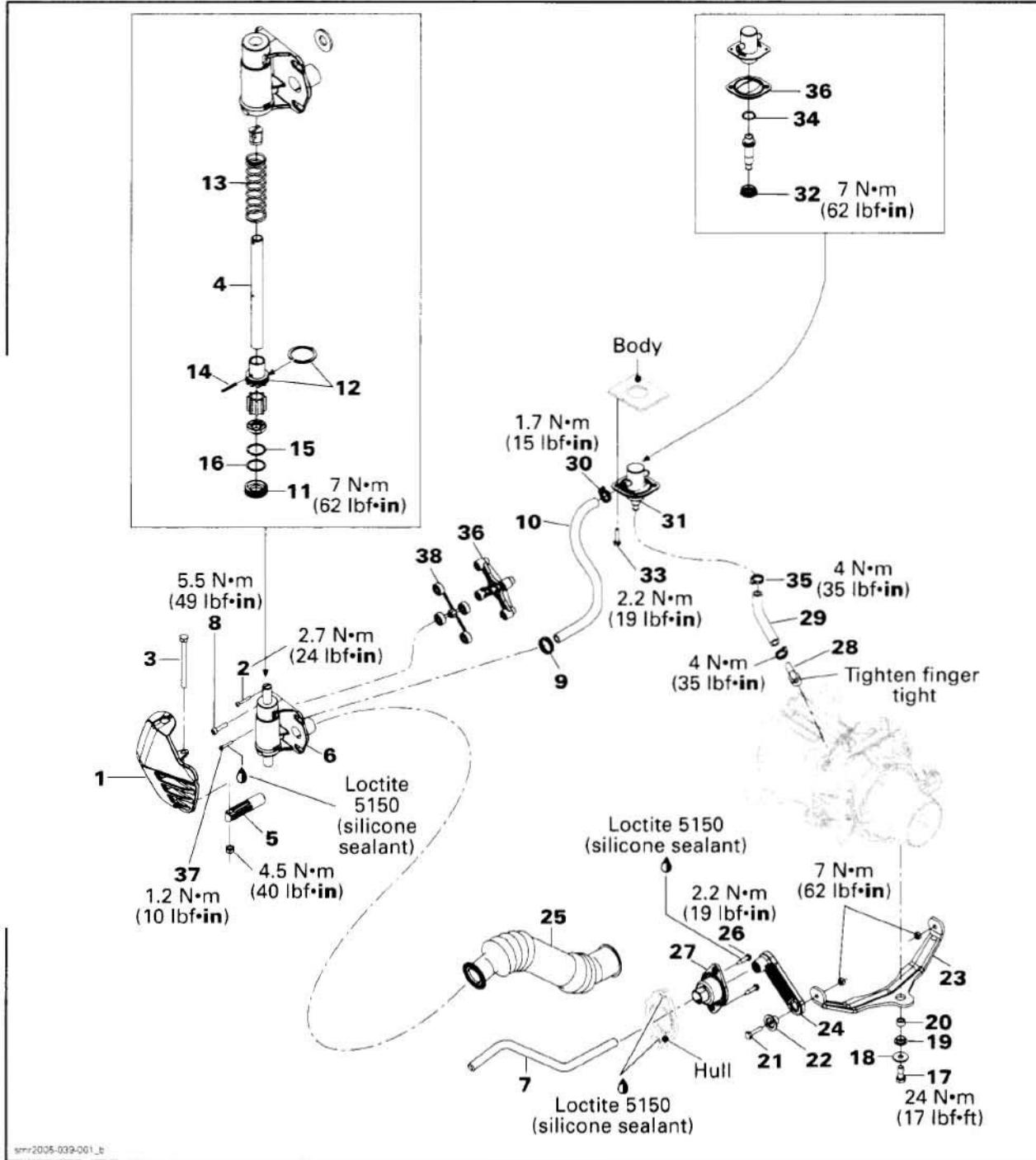

**Section 08 STEERING SYSTEM**  
 Subsection 02 (OFF-POWER ASSISTED STEERING (O.P.A.S.))

**GTI and RXP Series**

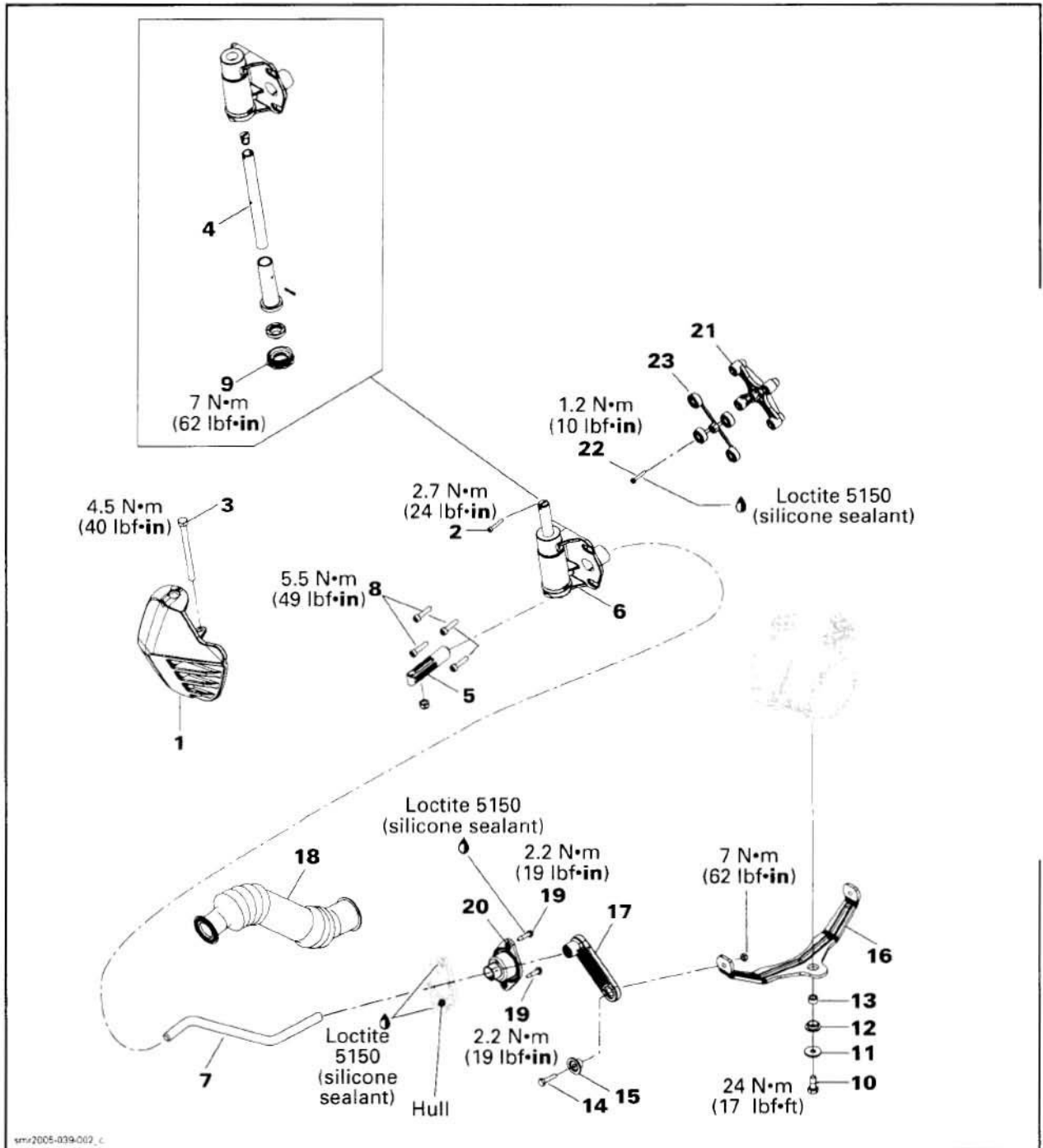

## Section 08 STEERING SYSTEM

### Subsection 02 (OFF-POWER ASSISTED STEERING (O.P.A.S.))

#### GENERAL

The Off-Power Assisted Steering (O.P.A.S.) uses a dual side vanes design that assists the watercraft steering in deceleration, to redirect watercraft path when steering is turned after throttle has been released or engine stopped.

The side vanes on the rear sides of the hull, turn as the steering is turned to assist the watercraft turning. At first, carefully experiment turning with this feature.

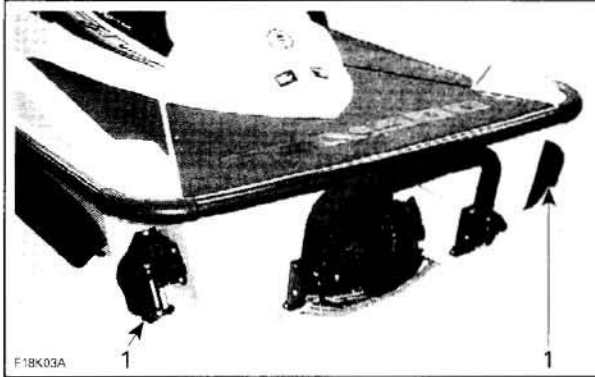

1. Side vanes turn following steering movement

#### GTX and RXT Series

When engine is running at approximately 75% or more RPM, the side vanes are automatically raised to upper position since they are not required at that vehicle speed range.

Between 30% and 75% engine RPM, side vanes are gradually raised from lower position to upper position.

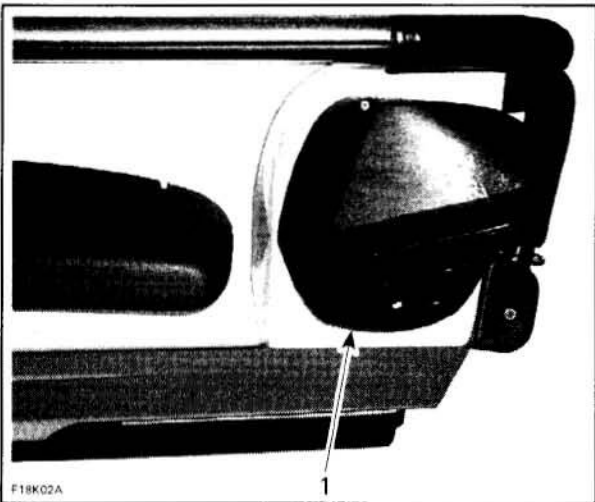

1. Side vane in upper position

When throttle is released and engine RPM drops, the side vanes are automatically lowered thus assisting steering control.

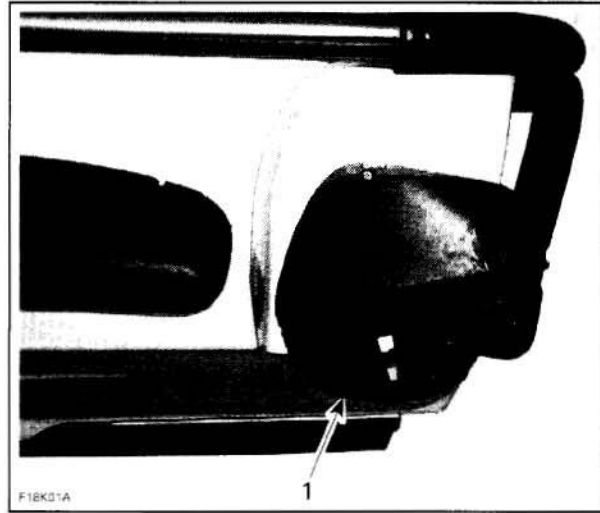

1. Side vane in lower position

#### GTX and RXP Series

These models do not have any vertical travel.

## PROCEDURES

### FILTER

#### GTX and RXT Series

#### Inspection

Check filter cleanliness as per the maintenance chart recommendations. Replace or clean it as necessary.

#### Removal

Unplug O.P.A.S. hose no. 29 from filter no. 28.

Unscrew filter.

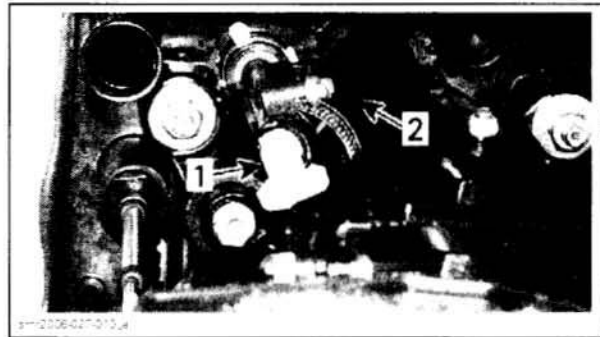

1. Filter  
2. O.P.A.S. hose

#### Installation

Install filter elbow at 20° angle to the right.



**Section 08 STEERING SYSTEM**  
Subsection 02 (OFF-POWER ASSISTED STEERING (O.P.A.S.))

It may exceed inside housing by 2.5 mm (.098 in).  
It may be positioned up to 2.0 mm (.078 in) from housing edge.

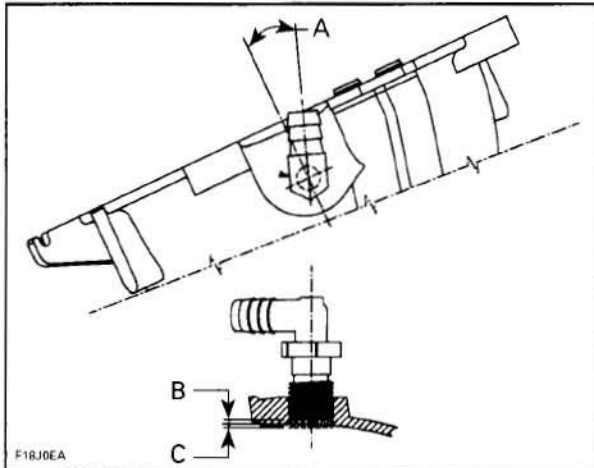

- F18J0EA
- A. 20°
  - B. 2.0 mm (.078 in)
  - C. 2.5 mm (.098 in)

Plug O.P.A.S. hose to filter.

## VALVE

### GTX and RXT Series

#### Removal

Remove O.P.A.S. "U" lever screw no. 17, flat washer no. 18, bushing no. 19 and venturi bushing no. 20 from nozzle.

Remove jet pump, filter and formed hose no. 29.

Remove gear clamps no. 30 to remove water hoses no. 31 from valve.

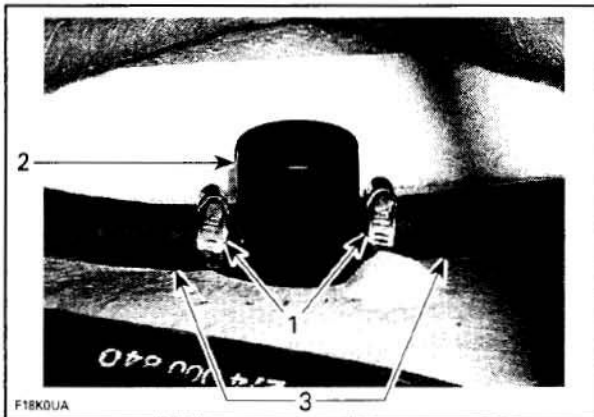

- F18K0UA
- 1. Gear clamps
  - 2. Valve
  - 3. Water hoses

If the disassembly of valve is necessary, loosen bottom nut of valve no. 32 using the O.P.A.S. cylinder nut wrench (P/N 529 035 840).

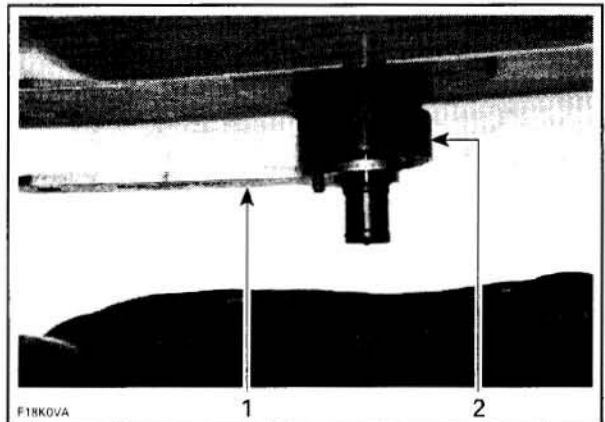

- F18K0VA
- 1. O.P.A.S. cylinder nut wrench
  - 2. Valve

Remove 2 Phillips screws no. 33 from valve collar.

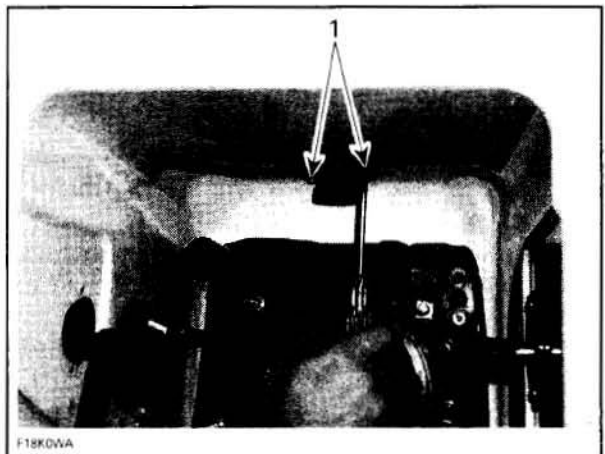

- F18K0VA
- TYPICAL
- 1. Phillips screws

Remove valve downwards from pump tunnel.

#### Disassembly and Assembly

Unscrew the bottom nut of valve completely, this will release all parts from the valve body.

Check if the O-ring no. 34 is brittle or hard. Replace if need be.

Assemble all parts and torque the bottom nut to 7 N•m (62 lbf•in).

#### Installation

Installation is the reverse process of removal, make sure of the following when doing installation:

- Check for cracks on formed hose no. 29, change if necessary.
- Install formed hose on valve. Torque clamp no. 35 manually to 4 N•m (35 lbf•in).
- Install a new gasket no. 36.

## Section 08 STEERING SYSTEM

### Subsection 02 (OFF-POWER ASSISTED STEERING (O.P.A.S.))

- Install the valve.
- Torque Phillips screws no. 33 to 2.2 N•m (19 lbf•in).
- Install water hoses no. 10 on valve.
- Tighten gear clamps no. 30 manually to 1.7 N•m (15 lbf•in).

## WATER HOSE

### GTX and RXT Series

#### Removal

Removal procedure for RH and LH water hose no. 10 is same.

Remove side vane no. 1 and cylinder support no. 6 as mentioned above.

Remove gear clamps no. 30 to remove water hose no. 10 from valve no. 31.

Pull out the water hose from exterior.

#### Installation

Installation is the reverse process of removal, make sure of the following when doing installation:

- Water hose must be installed from the outside to the inside of hull by turning it, oriented towards valve.
- Tighten gear clamps no. 30 manually to 1.7 N•m (15 lbf•in).

## SIDE VANE

#### Removal

Removal procedure for RH and LH side vane no. 1 is same.

Remove socket screw no. 2.

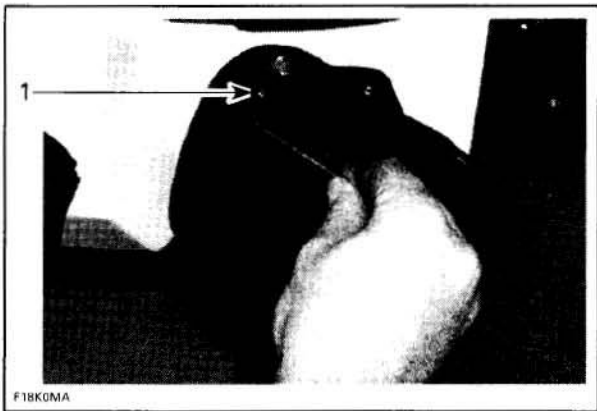

1. Socket screw

Remove the tie-rod screw no. 3.

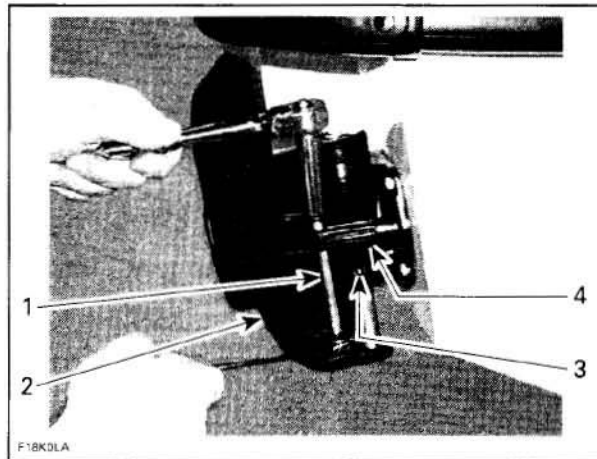

1. Tie rod screw  
2. Side vane  
3. Cylinder support  
4. Tie rod fitting

Lift pivot shaft no. 4 while holding top of side vane. Pull side vane out.

#### Adjustment

During tie-rod fitting adjustment, tie-rod screw no. 3 must be loose and socket screw no. 2 removed.

Put the steering in straight ahead position.

Measure the portion of tie rod fitting no. 5 exceeding from cylinder support no. 6.

The exceeding distance of tie rod fitting from the cylinder support should be  $45 \pm 1$  mm ( $1.65 \pm .04$  in).



A.  $45 \pm 1$  mm ( $1.65 \pm .04$  in)

To adjust the tie-rod fitting no. 5, remove tie-rod screw no. 3 and turn tie-rod fitting. Place tie-rod screw in its place and measure again. Repeat the procedure until the distance is reached.

When the adjustment is done, torque the tie-rod screw to 4.5 N•m (40 lbf•in).



## Section 08 STEERING SYSTEM

### Subsection 02 (OFF-POWER ASSISTED STEERING (O.P.A.S.))

Install socket screw no. 2 and torque it to 2.7 N•m (24 lbf•in).

**NOTE:** The socket screw no. 2 should be turned 2-3 turns before using a tool.

#### Installation

Installation is the reverse process of removal. Install the tie-rod screw no. 3. Do not torque yet. Perform the tie-rod fitting adjustment. See above.

### CYLINDER SUPPORT

#### Removal

Removal procedure for RH and LH cylinder support assembly is same.

Remove side vane as mentioned above.

**NOTE:** To disassemble the cylinder, it is not required to remove it from vehicle. See *DISASSEMBLY* procedure.

Unscrew tie rod fitting no. 5 from tie rod no. 7.

Unscrew 4 socket screws no. 8. Discard them.

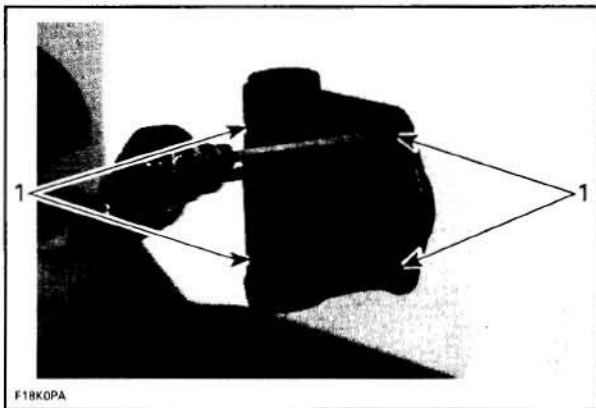

1. Socket screws

#### GTX and RXT Series

Remove Oetiker clamp no. 9 to remove water hose no. 10 from the cylinder support no. 6.

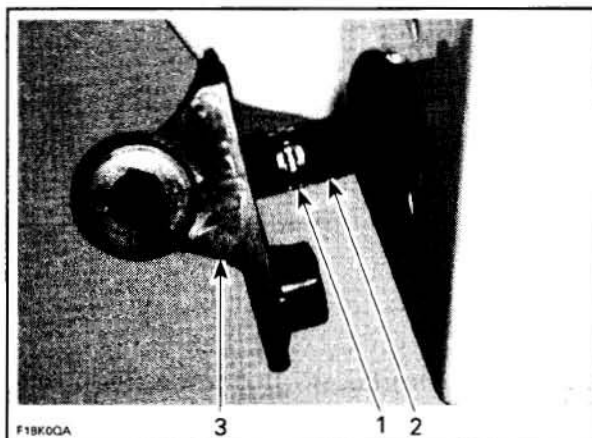

1. Oetiker clamp  
2. Water hose  
3. Cylinder support

#### Disassembly and Assembly

Unscrew cylinder cap no. 11 using the O.P.A.S. cylinder nut wrench (P/N 529 035 840).

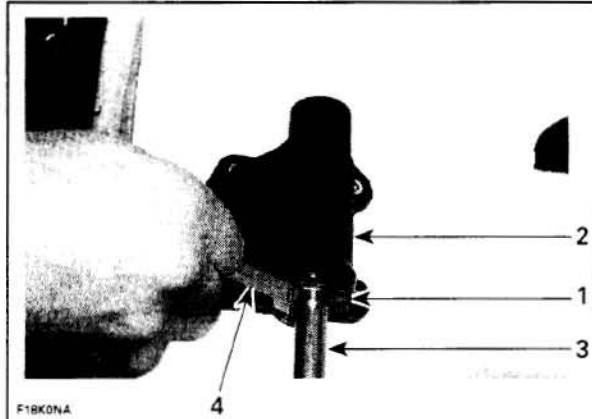
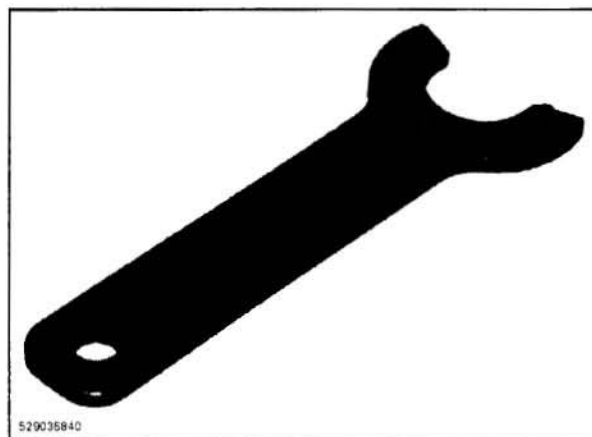

1. Cylinder cap  
2. Cylinder support  
3. Pivot rod  
4. O.P.A.S. cylinder nut wrench

Remove cylinder assembly out of cylinder support



## Section 08 STEERING SYSTEM

### Subsection 02 (OFF-POWER ASSISTED STEERING (O.P.A.S.))

#### GTX and RXT Series

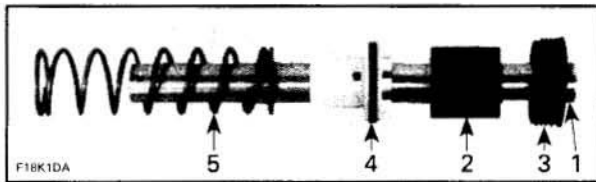

1. Pivot rod
2. Spacer
3. Cylinder cap
4. Piston
5. Spring

Discard the piston no. 12. Due to the presence of split rings around the piston, it must be replaced each time when removed for proper cylinder functionality.

To do this:

- Remove the spring no. 13.
- Remove the spring pin no. 14 from piston and pivot rod no. 4.

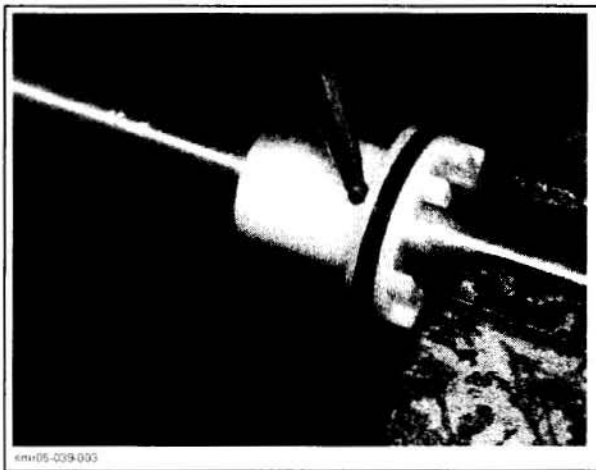

- Remove the piston.
- Check pivot rod no. 4 for cracks or scratches. Replace it, if necessary.
- Install a new piston with a new spring pin.

Before assembly, it will be necessary to change the split rings no. 15 and no. 16 inside cylinder cap no. 11. Do the following:

- To remove the upper split ring no. 15, lift one end over the cap tab.



- Turn the split ring to remove it from cap.



- Repeat the same procedure for the lower split ring no. 16.
- Install new split rings into cylinder cap. The opening of each split ring must be aligned with the appropriate lock inside cap.

## Section 08 STEERING SYSTEM

### Subsection 02 (OFF-POWER ASSISTED STEERING (O.P.A.S.))

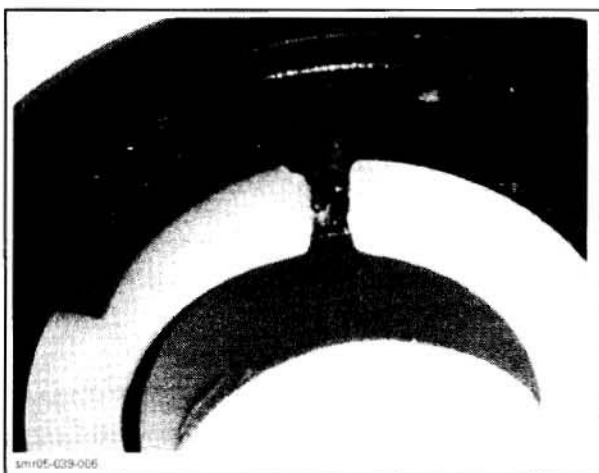

LOWER SPLIT RING

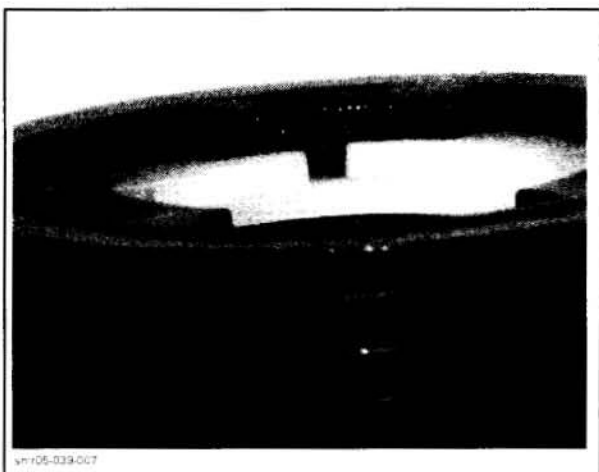

UPPER SPLIT RING

Install removed parts in the cylinder.

Using the O.P.A.S. cylinder nut wrench (P/N 529 035 840) torque the cylinder cap to 7 N•m (62 lbf•in). After tightening, keep turning the cap until the locking tab goes over the stopper.

#### GTI and RXP Series

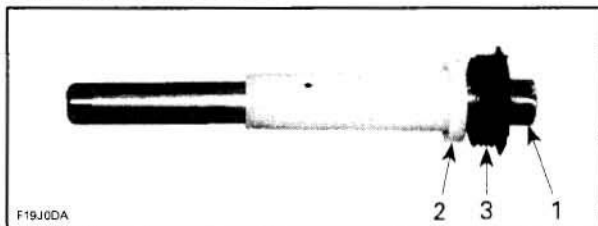

1. Pivot rod
2. Spacer
3. Cylinder cap assembly

The cylinder disassembly is not necessary for these models.

Check pivot rod no. 4 for cracks or scratches. Replace pivot rod, if necessary.

#### Installation

The installation is the reverse of the removal procedure. However, pay attention to the following detail.

Perform the tie-rod fitting adjustment. See above.

#### TIE ROD

##### Removal

Removal procedure for RH and LH tie rod no. 7 is same.

Remove side vane no. 1 and cylinder support no. 6 as mentioned above.

Remove O.P.A.S. "U" lever screw no. 17, flat washer no. 18, bushing no. 19 and venturi bushing no. 20 from nozzle.

Remove jet pump (refer to *JET PUMP*).

Remove screw no. 21 and washers no. 22 to remove "U" lever no. 23 from tie rod connecting levers no. 24.

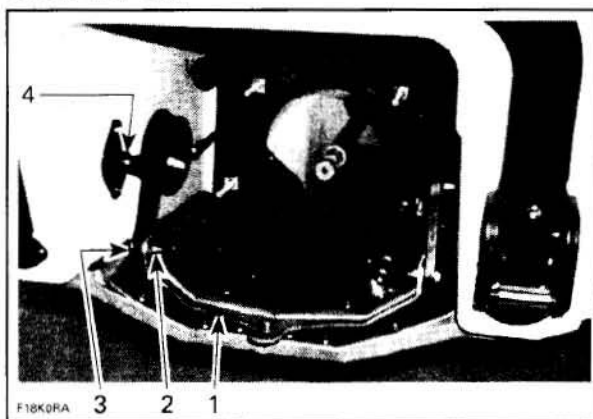

##### TYPICAL

1. "U" lever screw
2. Screw
3. Tie rod connecting lever
4. Tie rod

Pull tie rod out from jet pump side with the sealed tube no. 25.

Unscrew lever from the tie rod.

##### Installation

Installation is the reverse process of removal.

Torque screw no. 21 to 7 N•m (62 lbf•in).

Torque O.P.A.S. "U" lever screw no. 17 to 24 N•m (17 lbf•ft).

## Section 08 STEERING SYSTEM

### Subsection 02 (OFF-POWER ASSISTED STEERING (O.P.A.S.))

#### SEALED TUBE

##### Removal

Removal procedure for RH and LH sealed tube no. 25 is same.

Remove side van no. 1, cylinder housing no. 6 and O.P.A.S. "U" lever no. 23 as mentioned above.

Remove jet pump (refer to *JET PUMP*).

Remove Phillips screws no. 26 and remove rod grommet no. 27.

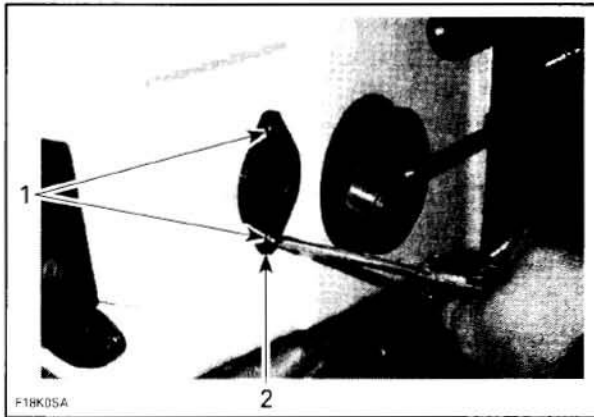

1. Phillips screws  
2. Rod grommet

Pull sealed tube out with tie rod from inside of bilge towards jet pump side.

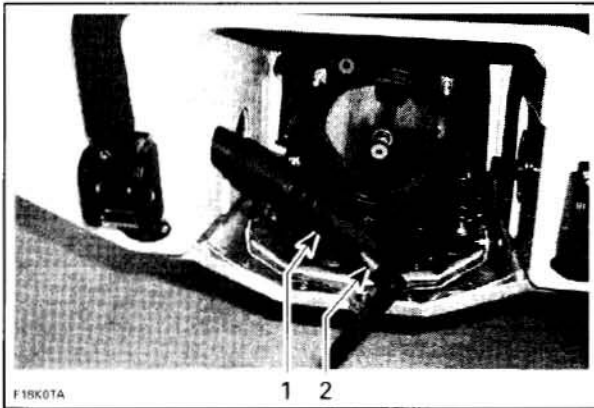

TYPICAL  
1. Sealed tube  
2. Tie rod

Remove old silicone sealant around screws holes.

##### Installation

Installation is the reverse process of removal.

Apply Loctite 5150 (silicone sealant) (P/N 293 800 086) on the screws before installing and, inside the hull, around screw holes after torquing.

Torque Phillips screws no. 26 to 2.2 N•m (19 lbf•in).

#### CROSS SUPPORT PLATE

##### Removal

###### For LH Side Cross Support Plate

Remove inlet hose, exhaust pipe and muffler (refer to *EXHAUST SYSTEM*).

###### For RH Side Cross Support Plate

Remove resonator (refer to *EXHAUST SYSTEM*).

**NOTE:** Use the same procedure for the RH or the LH cross support plate no. 36.

Remove side vane no. 1 and cylinder support no. 6 as mentioned above.

Unscrew the screw no. 37 retaining cross support plate no. 36 to hull.

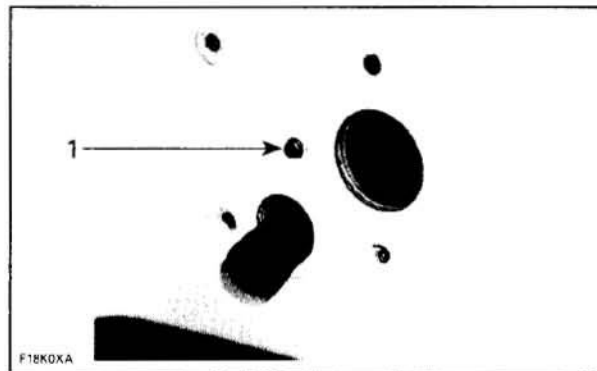

TYPICAL — GTX MODEL SHOWN  
1. Remove screw

Remove cross support plate from the inside of bilge.

##### Inspection

Check for cracks and deterioration of screw threads on cross support plate, replace if necessary.

Verify the condition of gasket no. 38 before installation, replace if necessary.



---

**Section 08 STEERING SYSTEM**  
Subsection 02 (OFF-POWER ASSISTED STEERING (O.P.A.S.))

---

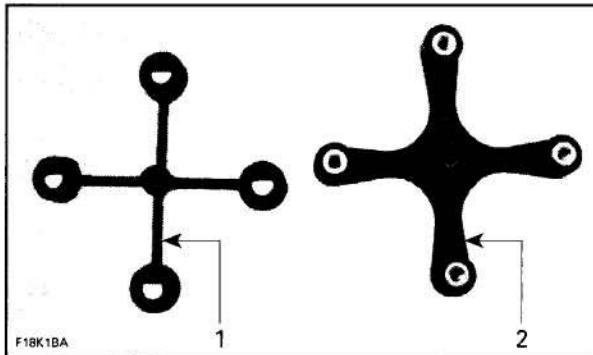

1. Gasket
2. Support plate

### Assembly

Assembly is the reverse process of disassembly, make sure of the following when doing assembly:  
Install the gasket on the cross support plate.

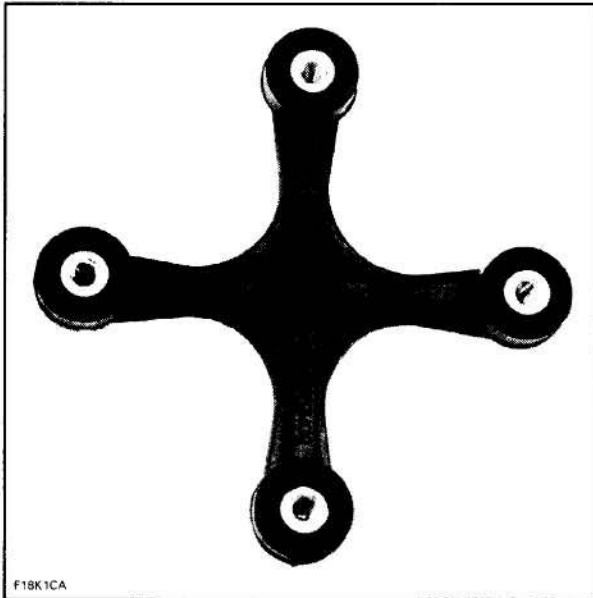

*GASKET INSTALLED ON SUPPORT PLATE*

From inside the bilge, install the cross support plate. Place the gasket against the hull then align the holes.

Torque screw no. 37 to 1.2 N•m (10 lbf•in).

# ADJUSTMENT AND REPAIR

## SERVICE TOOLS

<b>Description</b>	<b>Part Number</b>	<b>Page</b>
Oetiker pliers .....	295 000 070 .....	346
Supertanium™ drill bit .....	529 031 800 .....	341, 353

## SERVICE PRODUCTS

<b>Description</b>	<b>Part Number</b>	<b>Page</b>
BRP Plastic & Vinyl Cleaner .....	413 711 200 .....	362
Loctite 243 (blue) .....	293 800 060 .....	344, 348, 361
Loctite 271 (red) .....	293 800 005 .....	355
Loctite 5150 (silicone sealant) .....	293 800 086 .....	361–362
Loctite 518 .....	293 800 038 .....	358
Loctite 5900 .....	293 800 066 .....	355, 357–358

## Section 09 HULL/BODY

### Subsection 01 (ADJUSTMENT AND REPAIR)

#### GTI Models (body front view)

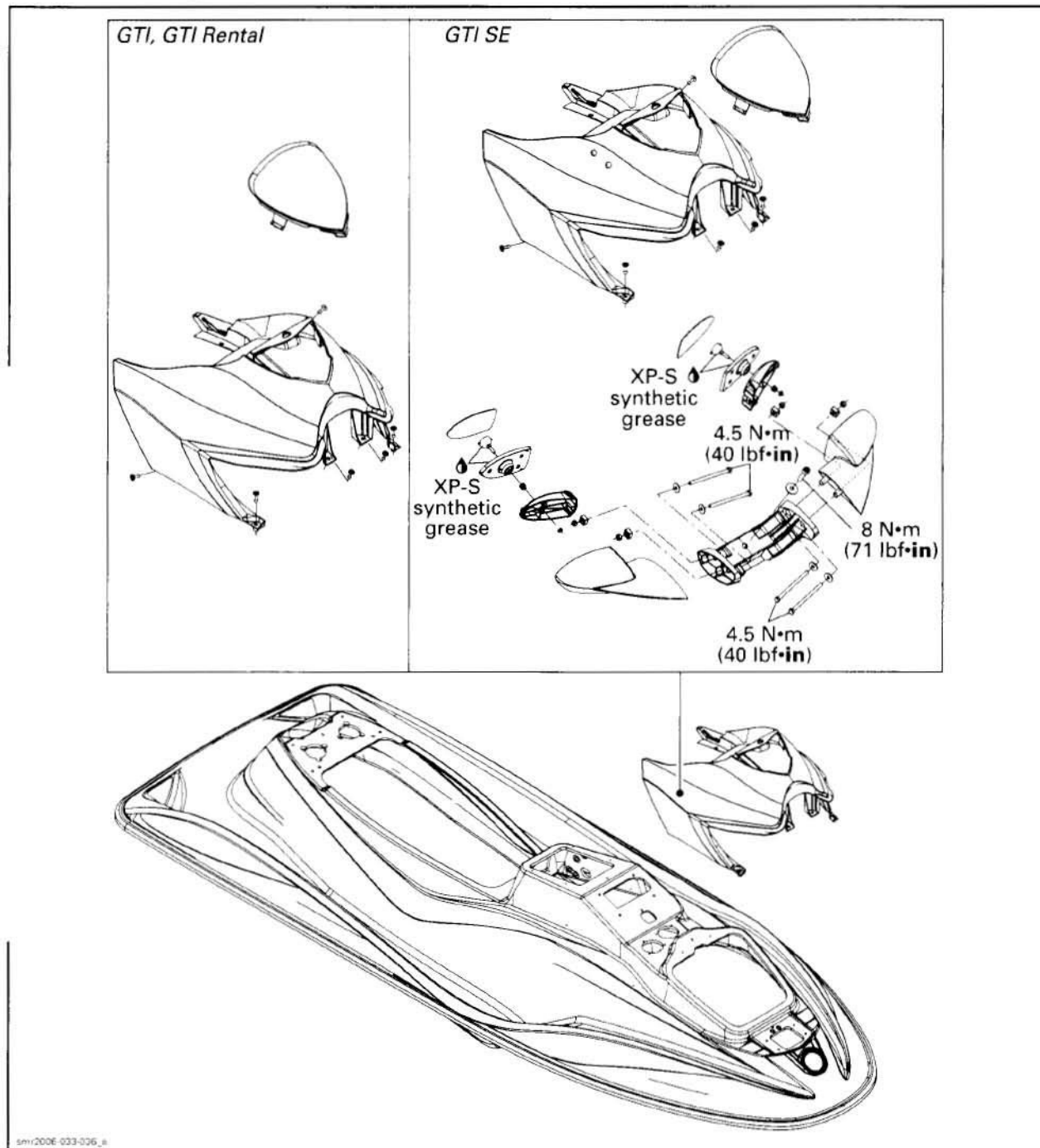



**Section 09 HULL/BODY**  
Subsection 01 (ADJUSTMENT AND REPAIR)

**GTI Models (body rear view)**

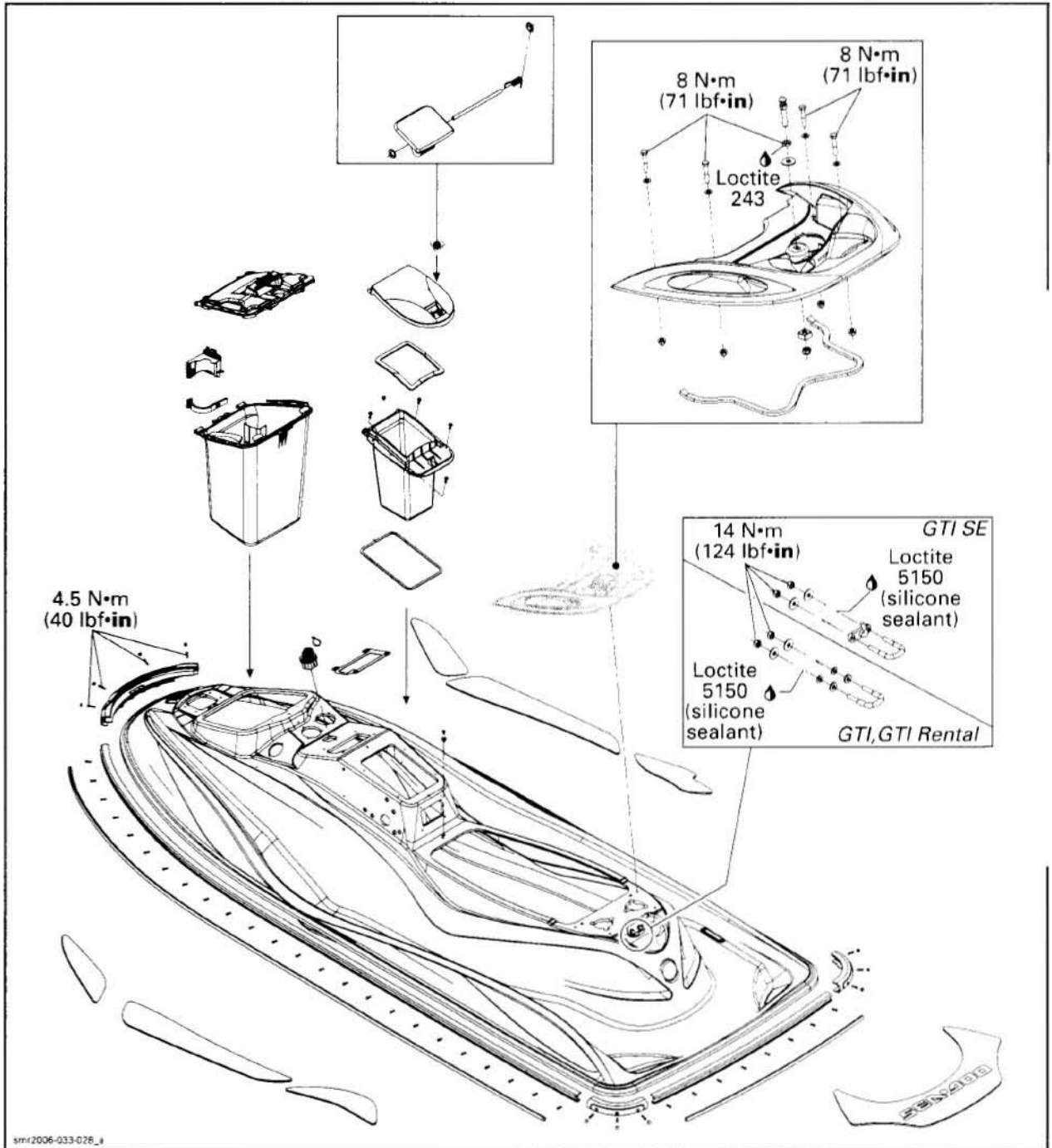

# Section 09 HULL/BODY

## Subsection 01 (ADJUSTMENT AND REPAIR)

### GTI Models (front storage compartment)

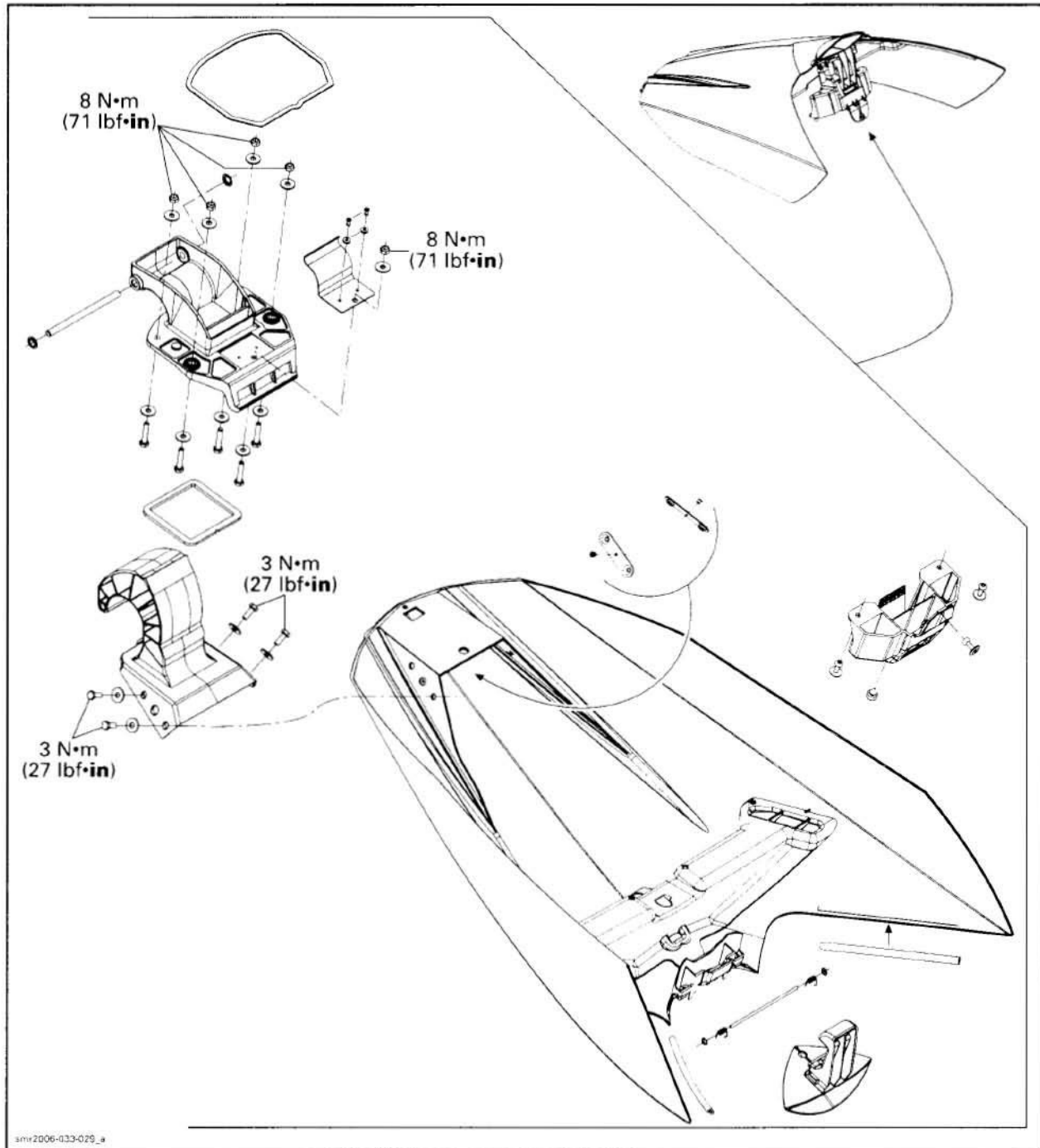

smr2006-033-029\_a

**Section 09 HULL/BODY**  
 Subsection 01 (ADJUSTMENT AND REPAIR)

**GTI Models (hull)**

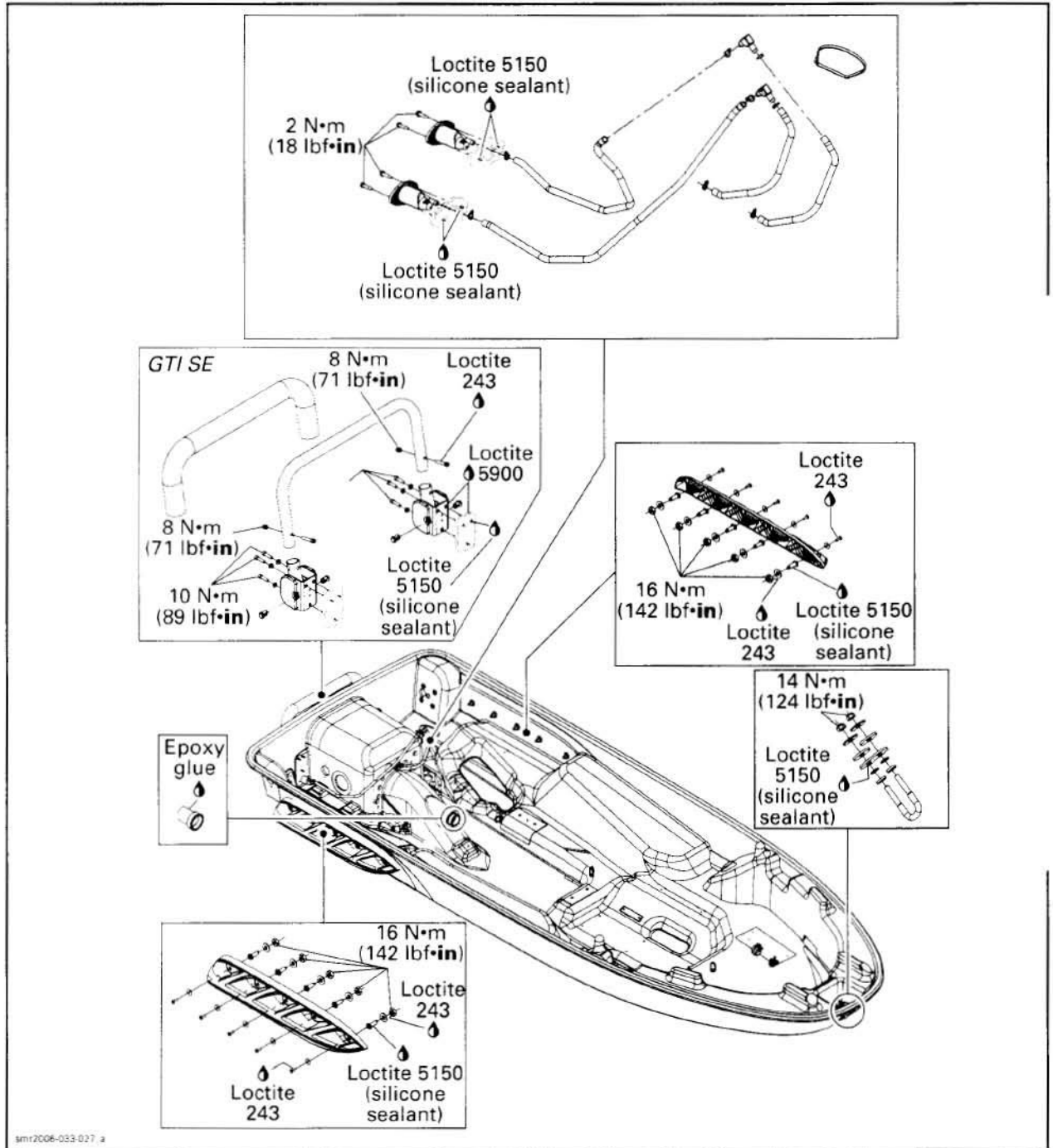

smr2006-033-027 a



**Section 09 HULL/BODY**  
Subsection 01 (ADJUSTMENT AND REPAIR)

**GTI Models (seats)**

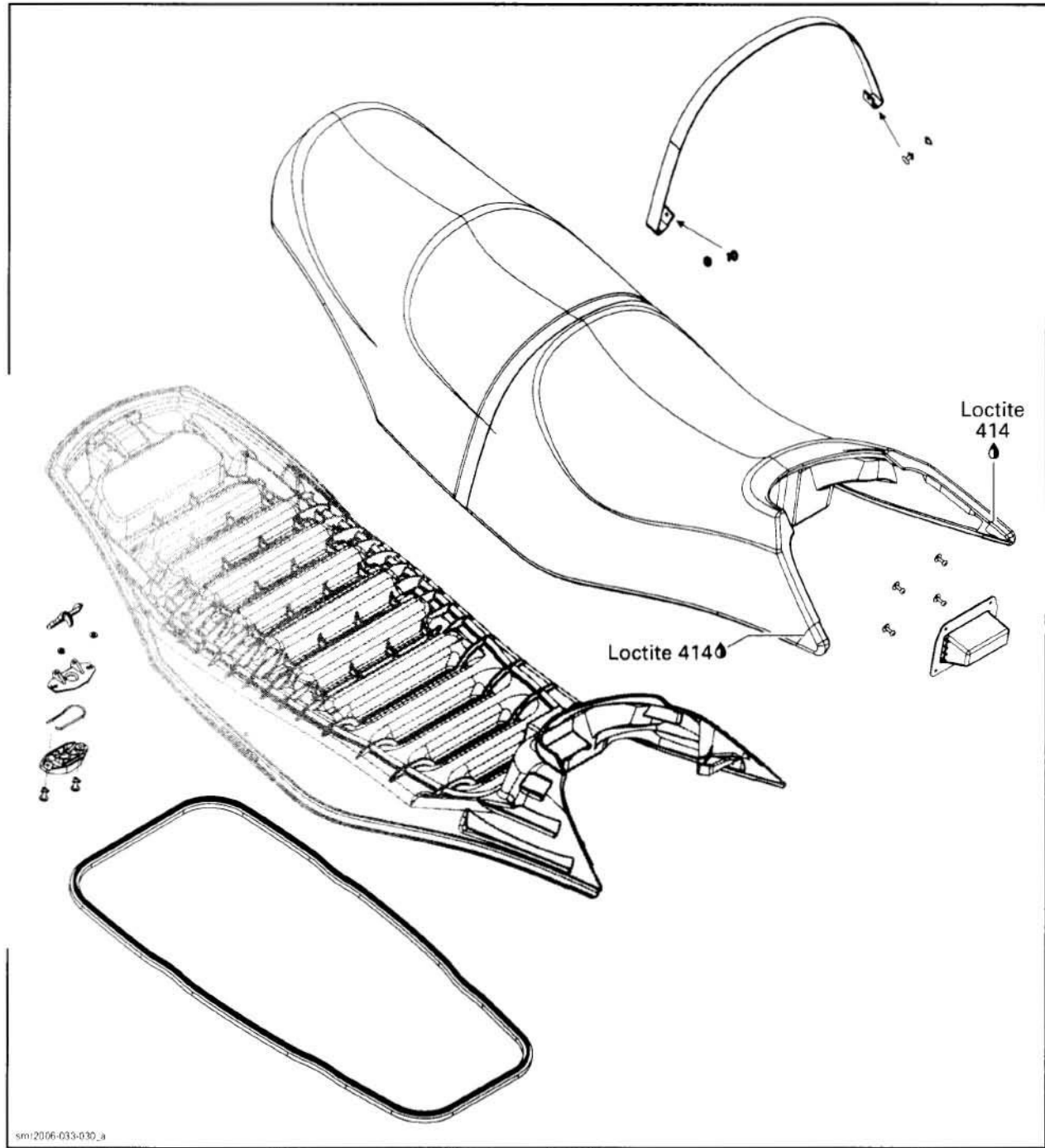

smr2006-033-030\_a

**Section 09 HULL/BODY**  
Subsection 01 (ADJUSTMENT AND REPAIR)

**GTX Series and RXT Models (body front view no. 1)**

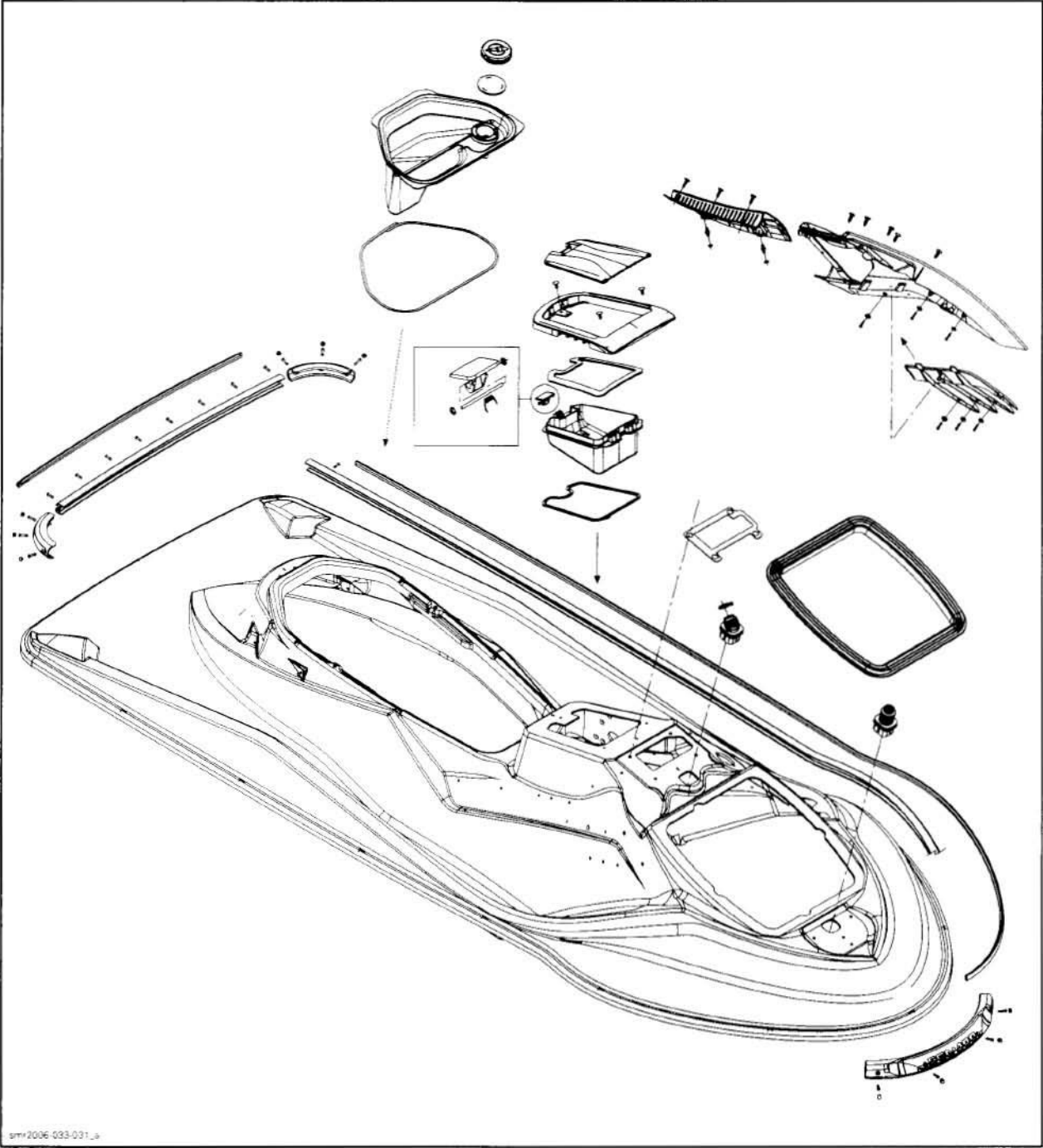

**Section 09 HULL/BODY**

**Subsection 01 (ADJUSTMENT AND REPAIR)**

**GTX Series and RXT Models (body front view no. 2)**

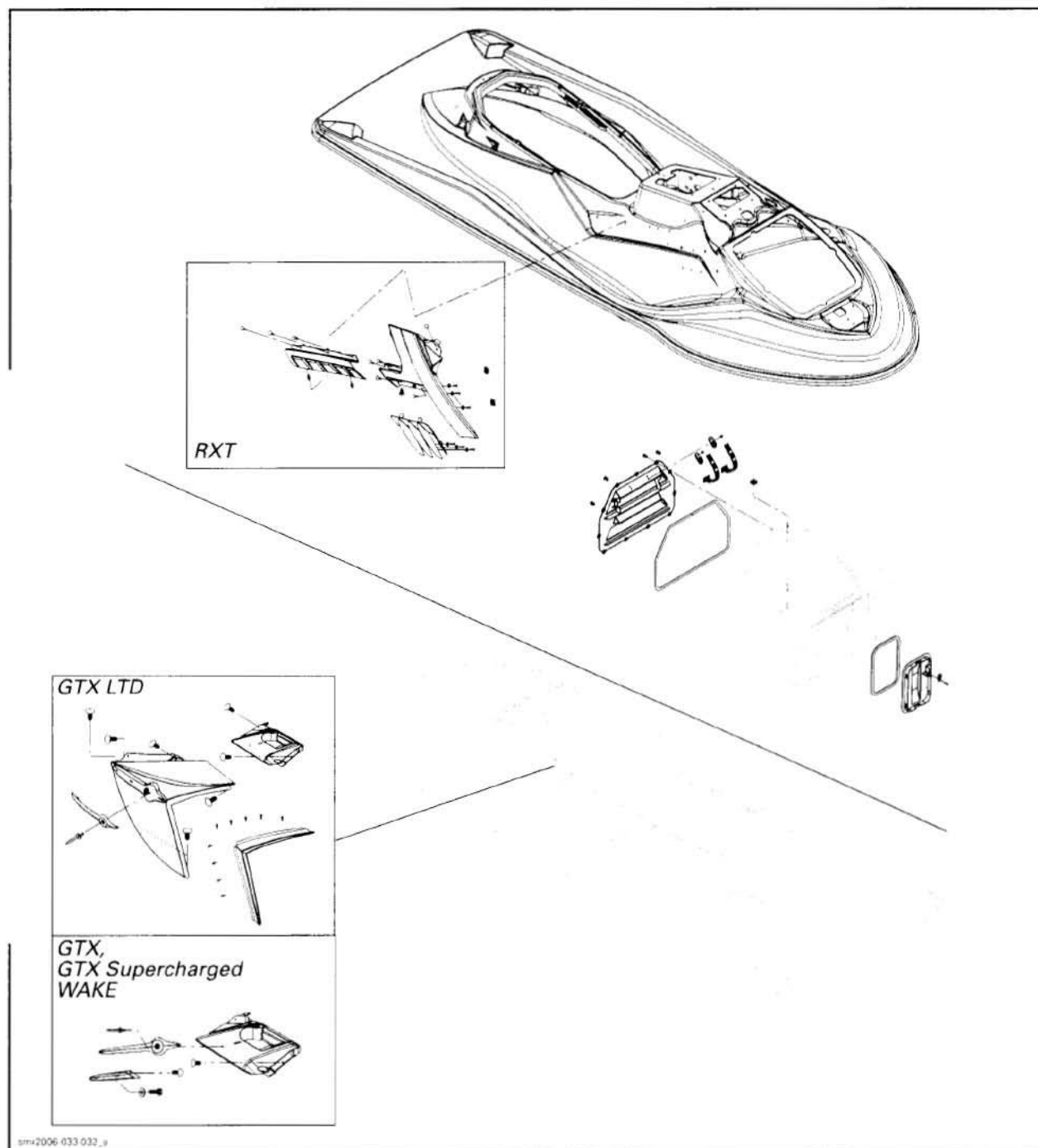



**Section 09 HULL/BODY**

**Subsection 01 (ADJUSTMENT AND REPAIR)**

**GTX Series and RXT Models (body rear view)**

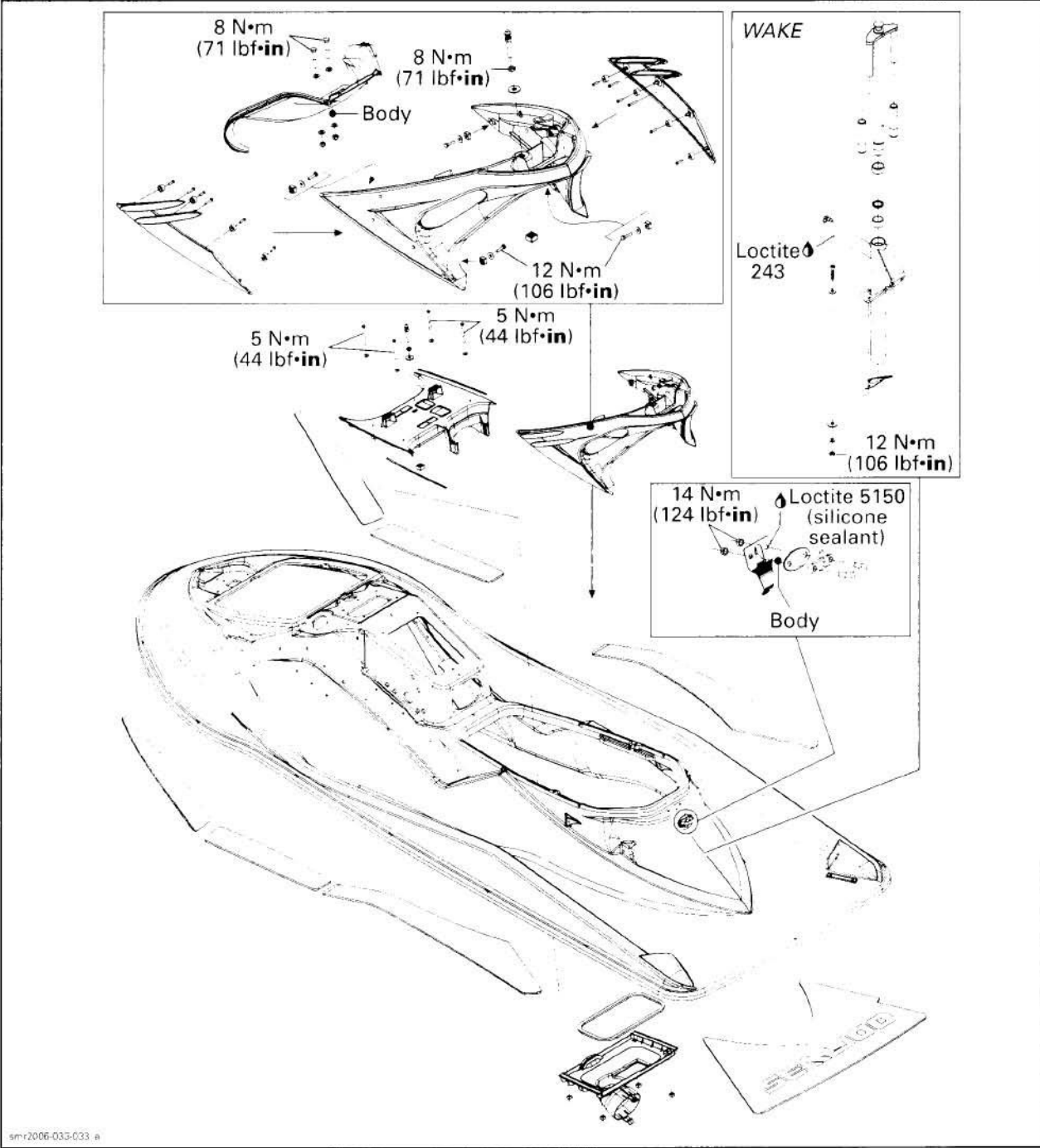

smr2006-033-033 a

# Section 09 HULL/BODY

## Subsection 01 (ADJUSTMENT AND REPAIR)

### GTX Series and RXT Models (front storage compartment)

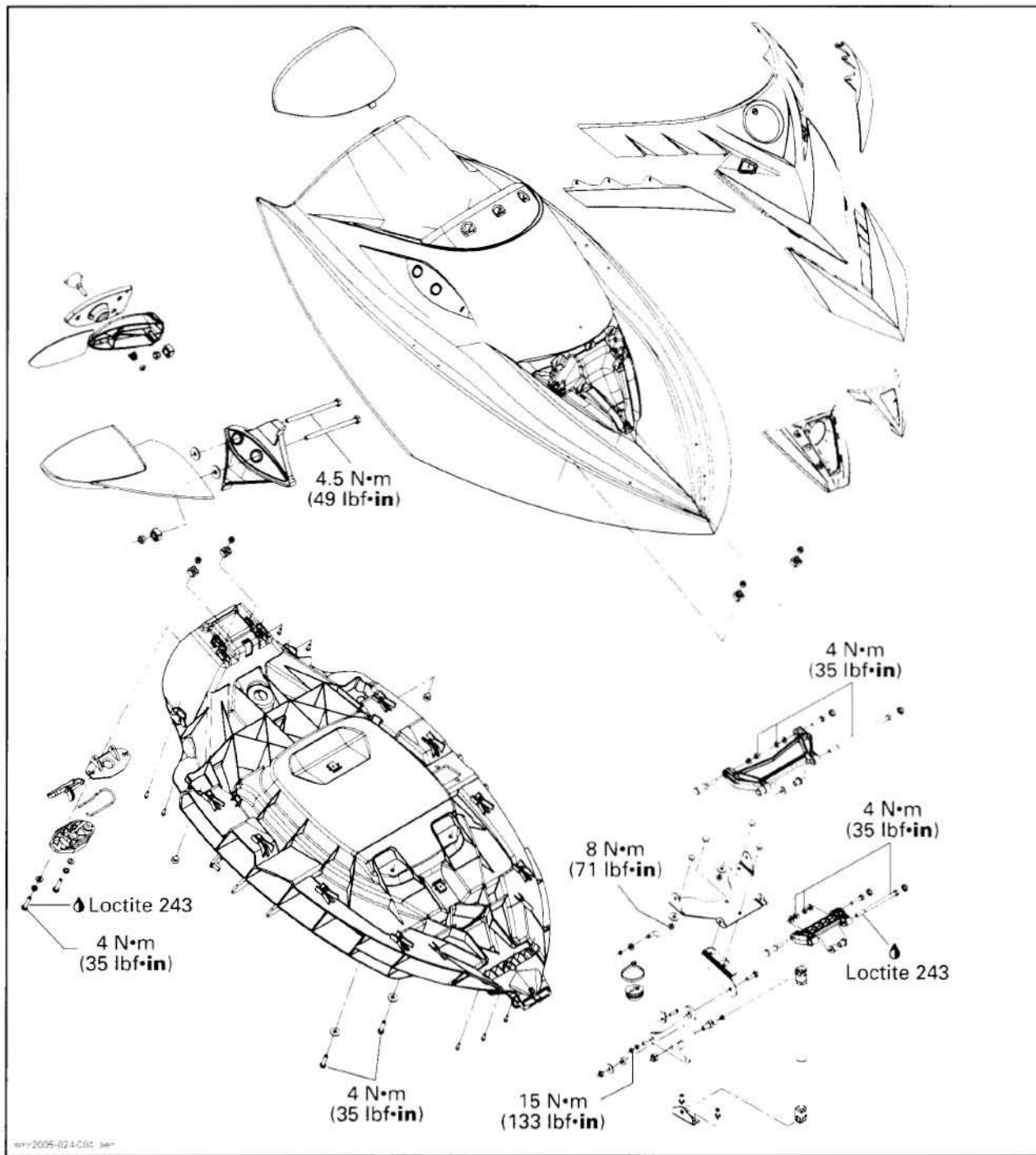

## Section 09 HULL/BODY

### Subsection 01 (ADJUSTMENT AND REPAIR)

#### GTX Series and RXT Models (hull)

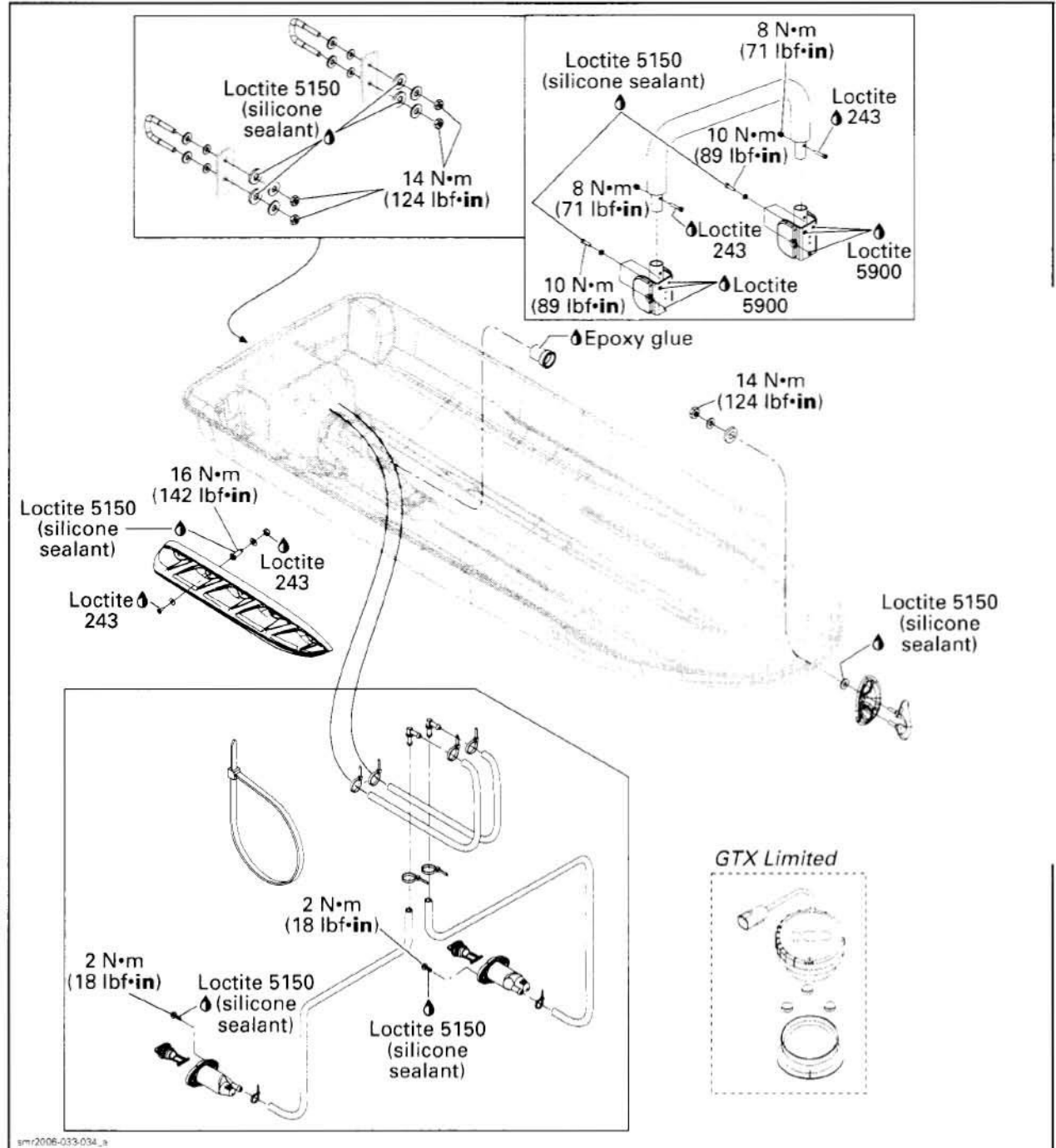







# Section 09 HULL/BODY

## Subsection 01 (ADJUSTMENT AND REPAIR)

RXP Models (body rear view no. 2)

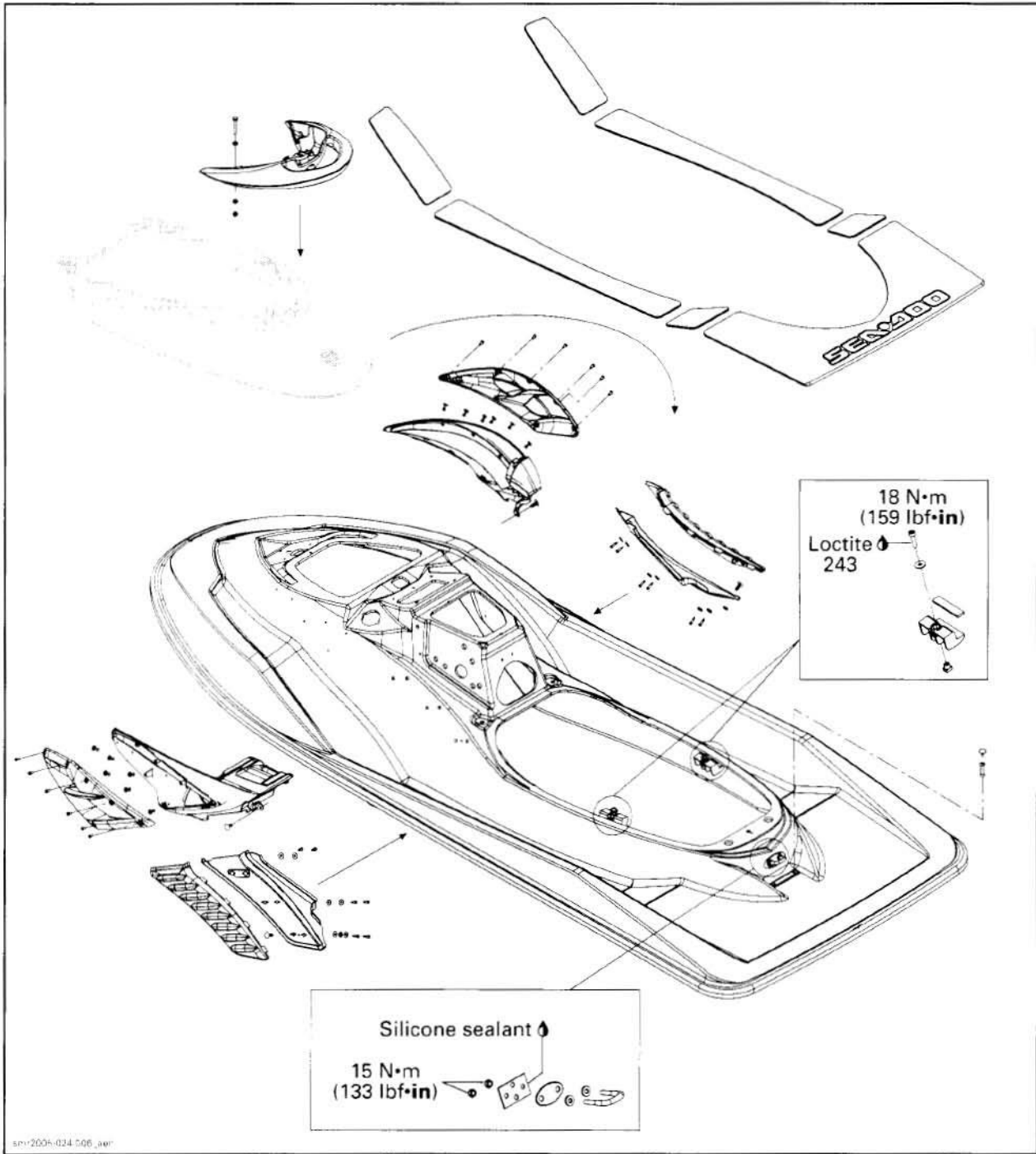

spr2006-024-006\_aer



**Section 09 HULL/BODY**

**Subsection 01 (ADJUSTMENT AND REPAIR)**

**RXP Models (hull)**

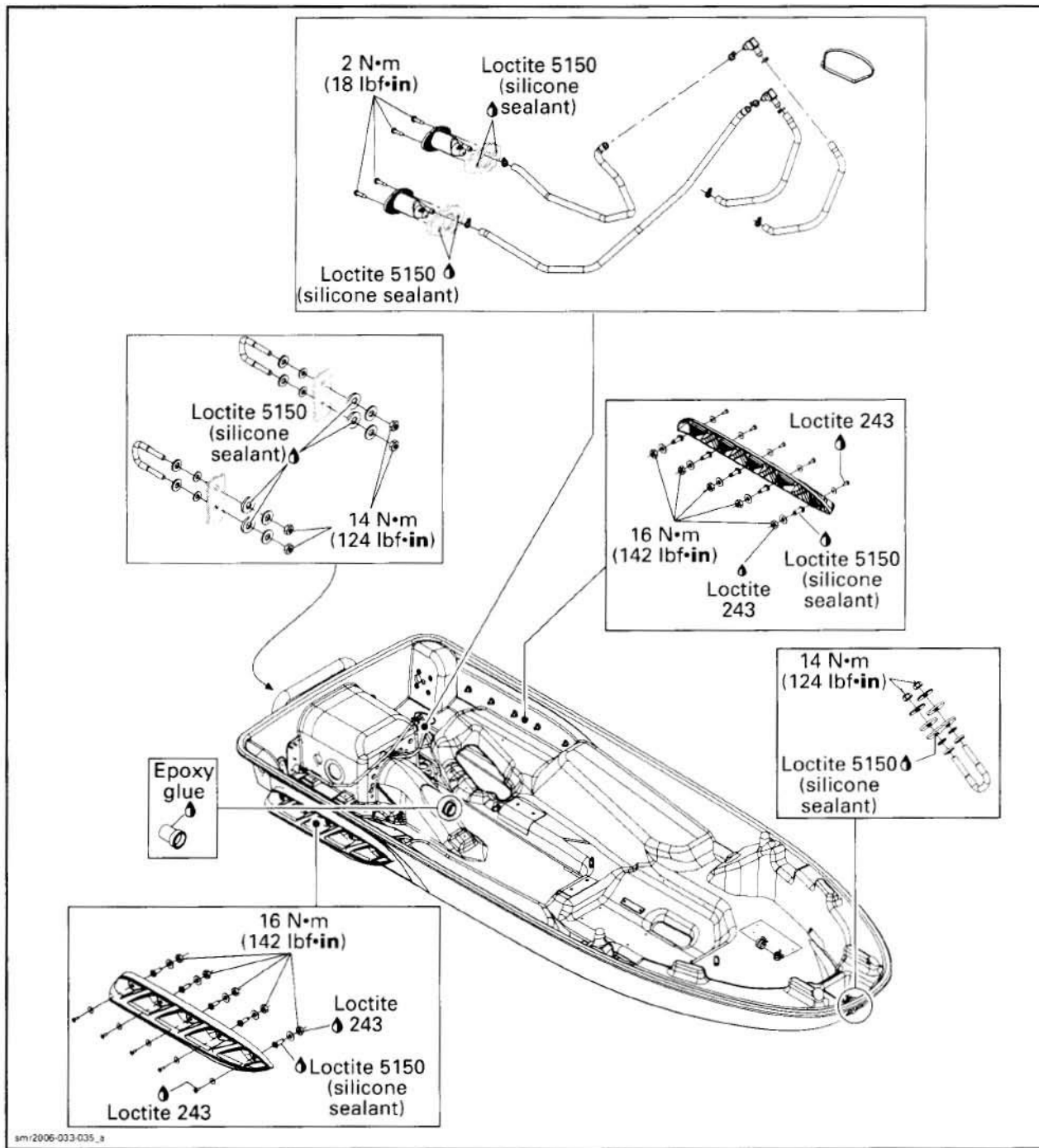

# Section 09 HULL/BODY

## Subsection 01 (ADJUSTMENT AND REPAIR)

### RXP Models (front storage compartment)

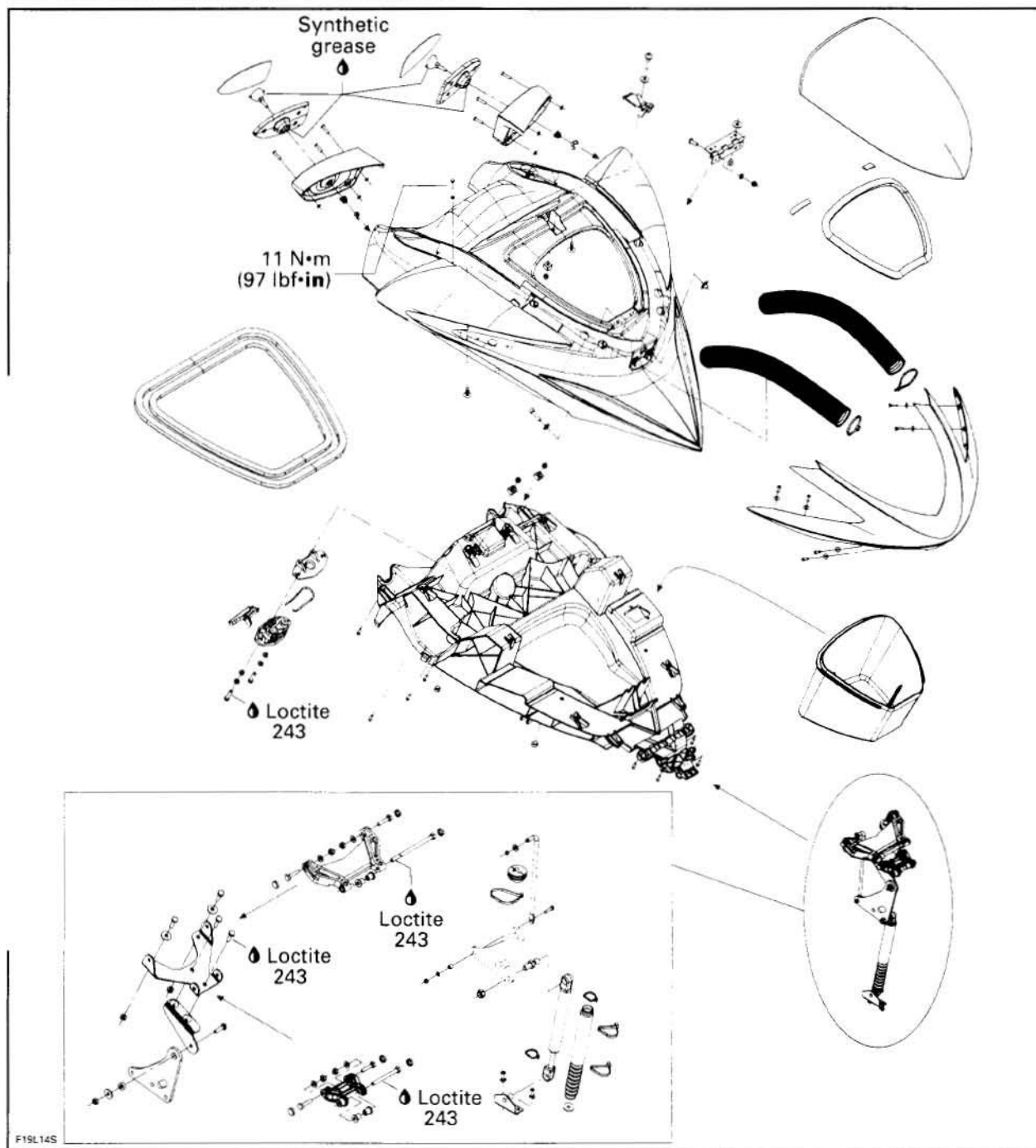

**Section 09 HULL/BODY**  
Subsection 01 (ADJUSTMENT AND REPAIR)

**RXP Models (seats)**

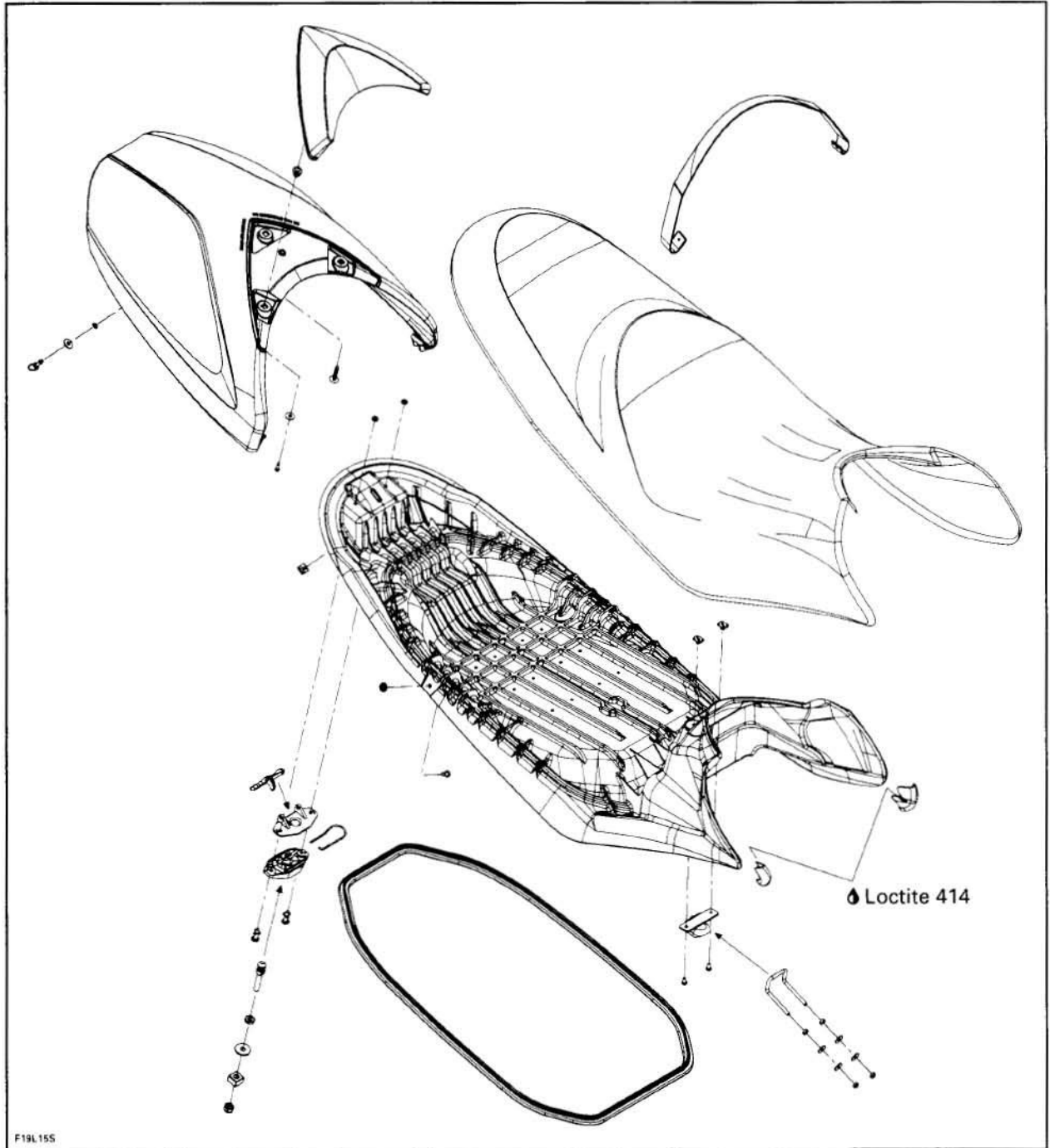



## Section 09 HULL/BODY

### Subsection 01 (ADJUSTMENT AND REPAIR)

#### GENERAL

Verify hinges condition and latching mechanisms condition and operation. Replace any damaged components.

During assembly/installation, use torque values and service products as in the exploded views.

Clean threads before applying a threadlocker. Refer to *SELF-LOCKING FASTENERS* and *LOCTITE APPLICATION* at the beginning of this manual for complete procedure.

**CAUTION:** When applying threadlocker products (anaerobic products), pay attention so that it does not come in contact with ABS plastic parts (painted parts). It could lead to plastic cracks or other damage.

#### WARNING

Torque wrench tightening specifications must strictly be adhered to.

Locking devices (e.g.: locking tabs, elastic stop nuts, self-locking fasteners, cotter pins, etc.) must be installed or replaced with new one where specified. If the efficiency of a locking device is impaired, it must be renewed.

#### PARTS REPLACEMENT

##### DECALS

###### Removal

Using a heat gun warm up one end of decal for a few seconds until decal can roll off when rubbing with your finger.

**NOTE:** When heating near light surfaces, duct tape should be applied to protect the surface. Otherwise the light color could become a yellowish color.

Pull decal slowly and when necessary apply more heat to ease removal on the area that has to be peeled off.

If decal tears while pulling off, it has to be heated for a few seconds longer. If decal tends to stretch while pulling off, stop heating and wait a few seconds to let it cool, then peel it off.

###### Installation of Decals Having a Protective Film on Back Side Only

These decals usually contain written information (e.g.: warning) and are used on gelcoat or metal.

Using isopropyl alcohol, clean the surface and dry thoroughly.

Using a pencil and the decal as a template, mark the area where decal will be located.

Remove half of the decal back protective film and align decal with marks. Start sticking it from center and remove the other half of the film to stick it completely. Carefully squeegee decal beginning at center and working outward using, firm, short, overlapping strokes.

###### Installation of Decals Having a Protective Film on Both Sides

These decals usually contain graphics and are used on gelcoat or plastic.

###### INSTALLATION ON GELCOAT

Using isopropyl alcohol, clean the surface and dry thoroughly.

Using a pencil and the decal as a template mark the area where decal will be located.

For better adhesion a dry application is recommended, however, to ease decal installation a mild solution of soapy water can be sprayed over surface where decal will be installed.

Remove back protective film from decal and align decal with marks. When well aligned squeegee decal beginning at center and working outward using firm, short, overlapping strokes.

Remove front protective film once decal has adhered to hull.

###### INSTALLATION ON PLASTIC (storage cover)

Clean surface with isopropyl alcohol and dry thoroughly.

Using a pencil and the decal as a template, mark the area where decal will be located.

**CAUTION:** Do not use soapy water to locate decal on plastic parts.

Remove back protective film from decal and carefully align decal with marks. When well aligned squeegee decal beginning at center and working outward using firm, short, overlapping strokes.

Remove front protective film once decal has adhered.

#### GLOVE BOX

##### Removal

###### *GTI Series*

Place shift lever in forward position.

Lift the glove box cover.

**Section 09 HULL/BODY**  
Subsection 01 (ADJUSTMENT AND REPAIR)

Using a Supertanium™ drill bit (P/N 529 031 800), drill both rivets holding glove box to body.

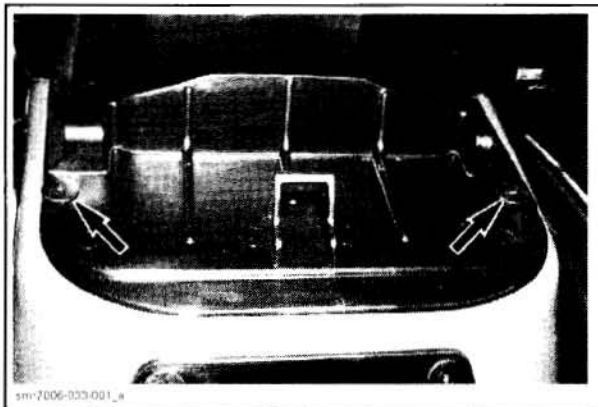

Slide glove box cover to open it, and drill the rivets on each side of glove box.

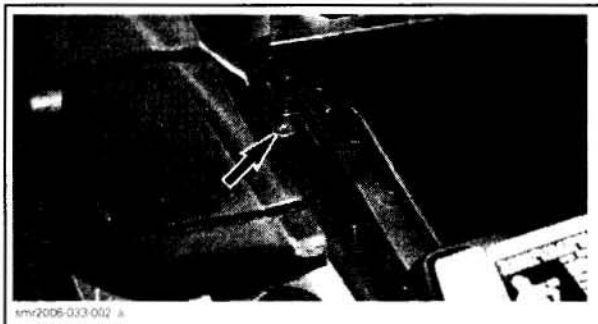

Pull glove box to remove it.

**GTX Series and RXT Models**

Lift the glove box top cover.

Gently push on both rear tabs while lifting out rear of glove box compartment.

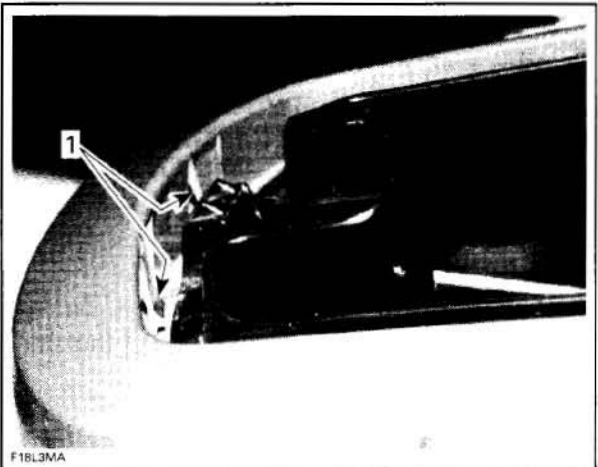

1. Push tabs

Pull the glove box out of body.

**RXP Models**

Place shift lever in forward position.

Remove seat.

Pull dart out. See illustration.

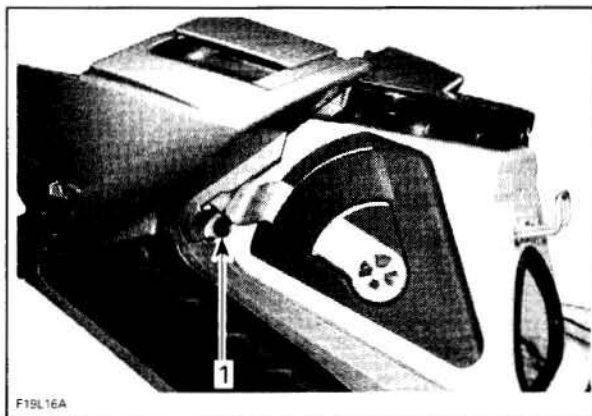

1. Pull dart out

Carefully pull the side molded part to release the glove box. Pulling too much might lead to damaging the part.

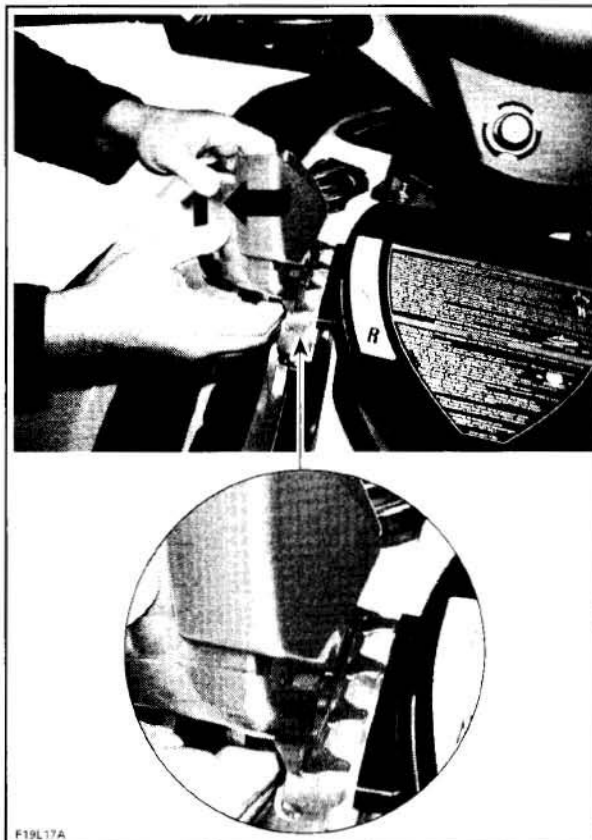

RELEASE SIDE MOLDED PART FROM GLOVE BOX

Slightly lift glove box to free it.



## Section 09 HULL/BODY

### Subsection 01 (ADJUSTMENT AND REPAIR)

Proceed with the other side the same way to finally pull glove box out.

#### Installation

Reverse the removal procedure.

## SEAT

### Removal

#### Rear Seat

##### **GTX Series and RXT Models**

Removing the rear seat allows access to the rear storage basket. It also gives access to the front seat latch.

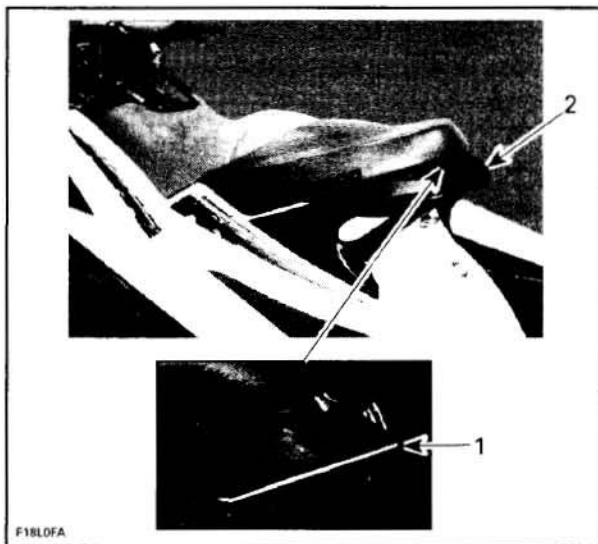

TYPICAL

1. Rear seat latch
2. Rear grab handle

#### Front Seat

The front seat latch is located at the rear end and underneath the seat.

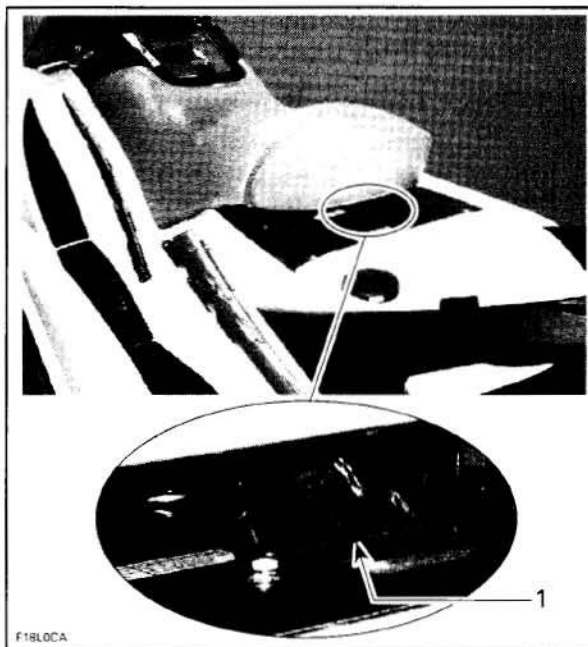

F18LOCA

TYPICAL — SEAT WITH REAR SEAT

1. Seat latch

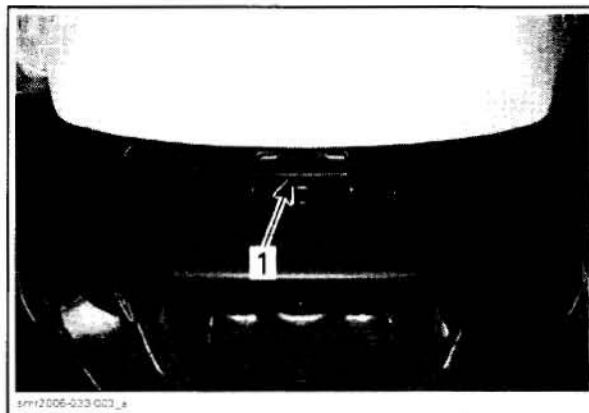

smr2006-033 023\_a

TYPICAL — SEAT WITHOUT REAR SEAT

1. Seat latch

To remove front seat, pull the latch lever upward and hold. Lift and pull the seat rearward.

#### Installation

##### Front Seat

To latch front seat, align latch hole with pin then, firmly push down on the rear portion of the seat.



**Section 09 HULL/BODY**  
Subsection 01 (ADJUSTMENT AND REPAIR)

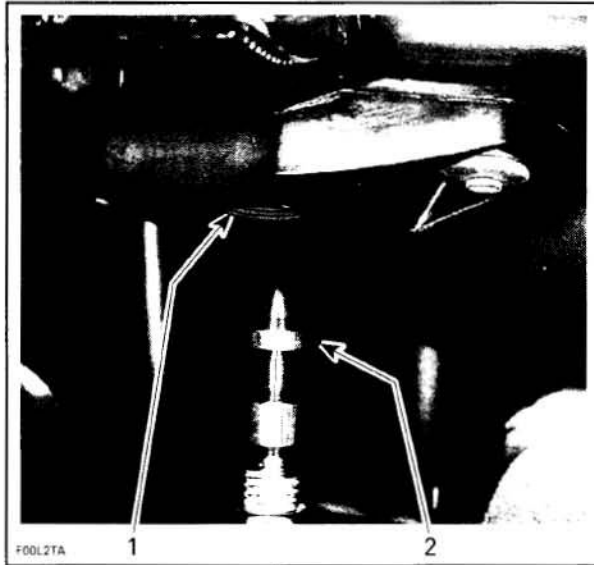

1. Latch hole  
2. Pin

**Rear Seat**

The installation is the reverse of the removal procedure.

**REMOVABLE SEAT COWLING**

**RXP Models**

**Removal**

The removable seat cowling allows to install a number on its side panels. It is removable to expose the seat for a passenger.

To remove cover:

- Unlatch and pull seat out.
- Unlock the quarter-turn screws.

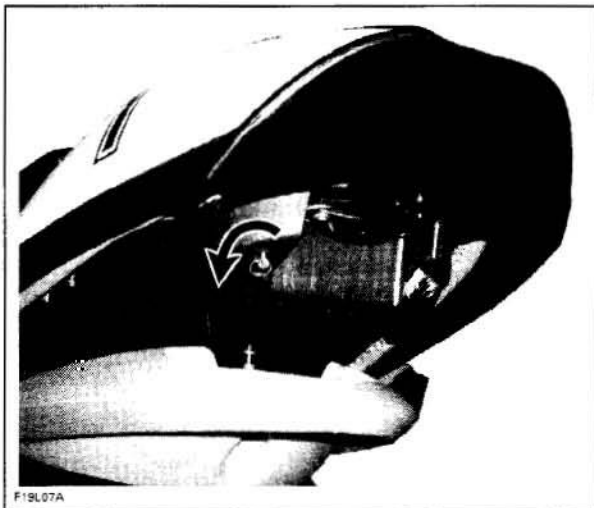

- Pull cover tabs each side of seat then remove seat cowling.

**Installation**

To reinstall seat cowling:

- Unlatch and pull seat out.
- Position rear of seat cowling in place without inserting front tabs yet.
- Carefully pull tabs outward each side of seat and insert seat cowling in place.

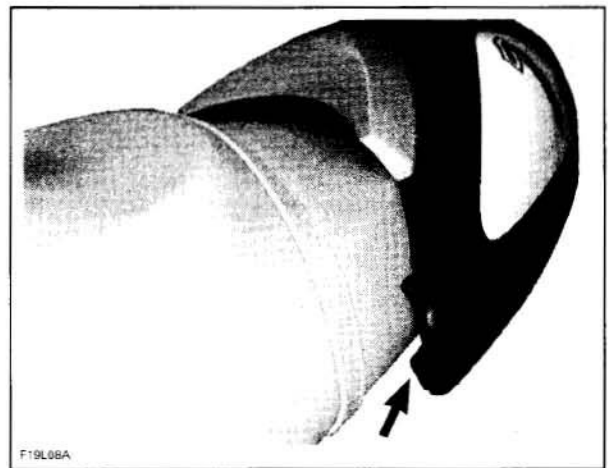

- Finish pushing seat cowling in position then lock the quarter-turn screws.
- Install seat and properly relatch.

**SEAT COVER**

**Replacement**

Remove the old seat cover. Check the foam and replace it if necessary.

Install staples with an electric tacker such as Arrow tacker no. ETN-50 or with a manual tacker such as Arrow tacker no. T-50.

**NOTE:** For an easier installation, it's highly recommended to use an electric tacker.

Ensure that the seat rest firmly against a hard surface such as a piece of wood. This is done to get the staples completely pushed in place.

## Section 09 HULL/BODY

### Subsection 01 (ADJUSTMENT AND REPAIR)

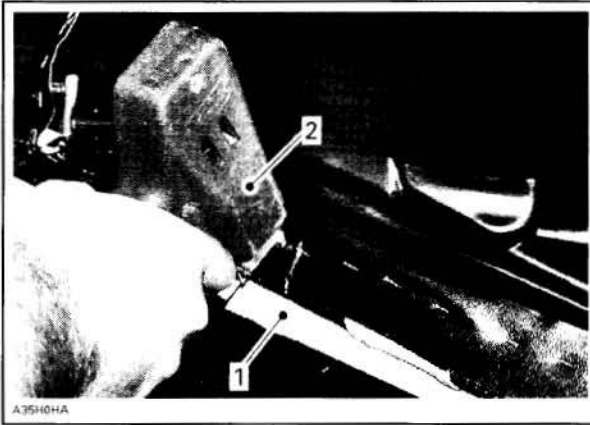

**TYPICAL**

1. Piece of wood
2. ETN-50 (electric) or T-50 (manual)

After seat cover installation, cut all around the excess of material.

## SEAT LATCH

### Adjustment

**NOTE:** Apply Loctite 243 (blue) (P/N 293 800 060) on threads of lock pin when the adjustment is required or when the lock pin is removed then reinstalled. The threads on new lock pin are coated with a self-locking product, do not apply Loctite 243 on threads.

#### GTI Series

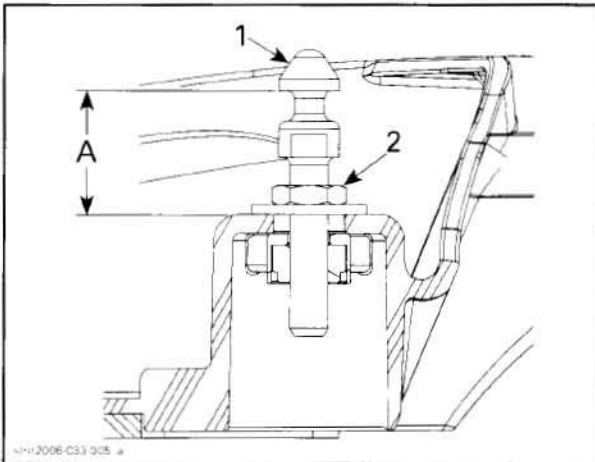

**TYPICAL**

1. Lock pin
2. Adjustment nut (Loctite 243). Torque to 8 N•m (71 lbf•in)
- A. 32.5 ± 1 mm (1-9/32 ± 3/64 in)

#### GTX Series, Wake and RXT Models

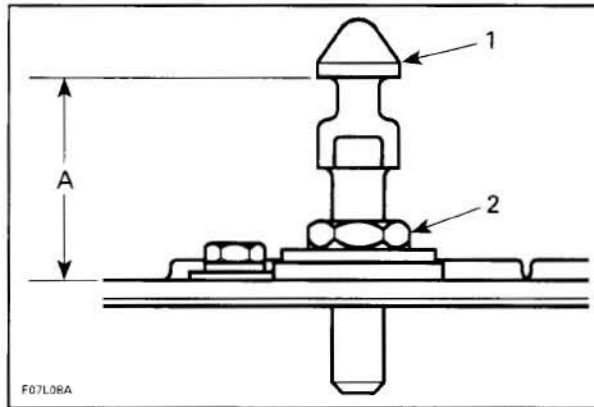

**TYPICAL — FRONT SEAT**

1. Lock pin
2. Adjustment nut (Loctite 243). Torque to 8 N•m (71 lbf•in)
- A. 33 ± 1 mm (1-35/64 ± 3/64 in)

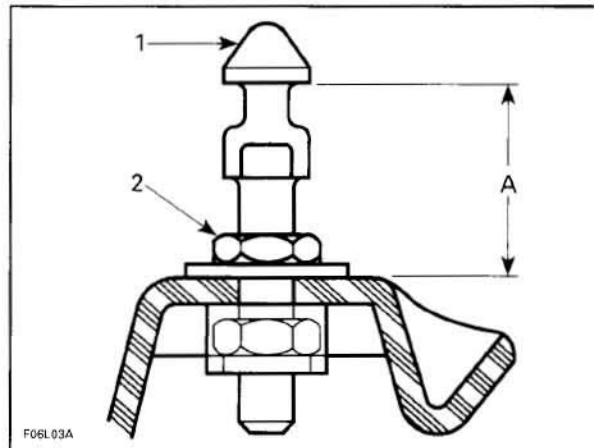

**TYPICAL — REAR SEAT**

1. Lock pin
2. Adjustment nut (apply Loctite 243). Torque to 5 N•m (44 lbf•in)
- A. 35 ± 1 mm (1-5/16 ± 3/64 in)

#### RXP Models

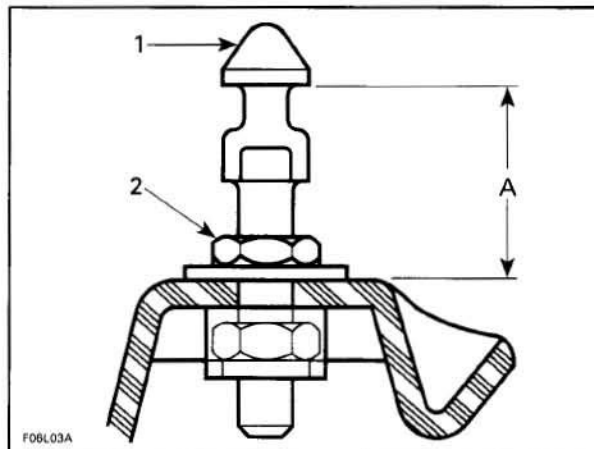

1. Lock pin
2. Adjustment nut (apply Loctite 243). Torque to 8 N•m (71 lbf•in)
- A. 36 ± 1 mm (1-35/64 ± 3/64 in)

## ENGINE COVER

### *RXP Models*

Remove seat.

Detach coolant expansion tank and move away.



1. Coolant expansion tank

Remove BRP logo at rear.

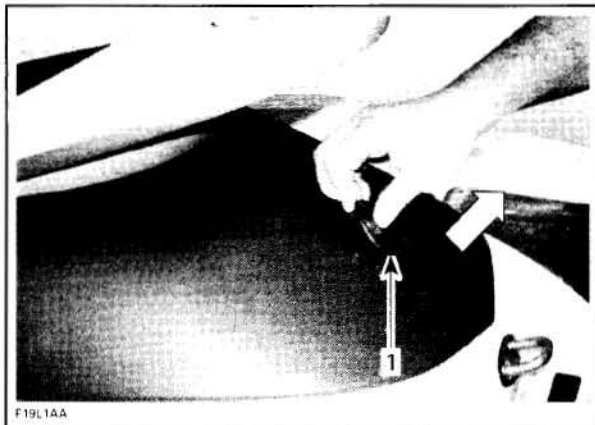

1. Logo

Remove retaining screws.

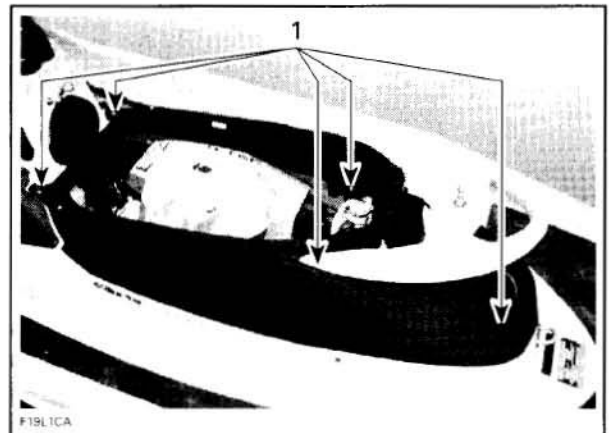

1. Retaining screws

**NOTE:** Pay attention not to drop retaining blocks under cover when removing screws.

Pull out engine cover.

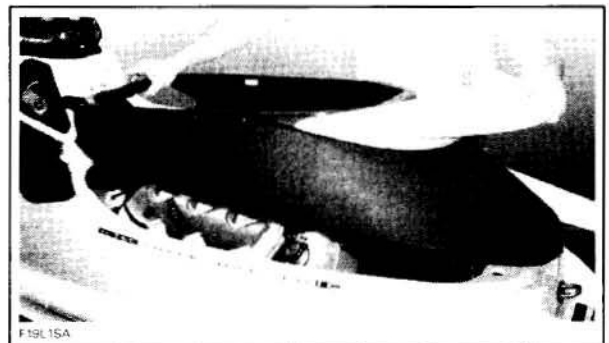

Assembly is the opposite procedure of removal. Ensure to tighten screws in a criss-cross order and to torque to 18 N•m (159 lbf•in).

## STORAGE COMPARTMENT COVER

### Removal

#### *GTI Series*

Open storage compartment cover.

Unscrew bolts retaining the cover to its hinge (two on each side). Discard them.



## Section 09 HULL/BODY

### Subsection 01 (ADJUSTMENT AND REPAIR)

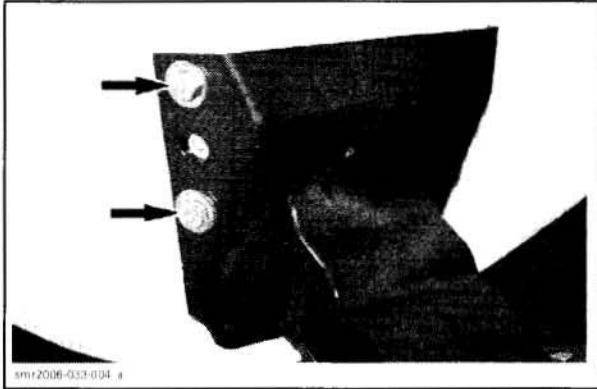

Remove storage compartment cover.

#### **All Models except GTI Series**

Open storage compartment cover.

Remove access panel. To remove access panel darts, use the Oetiker pliers (P/N 295 000 070).

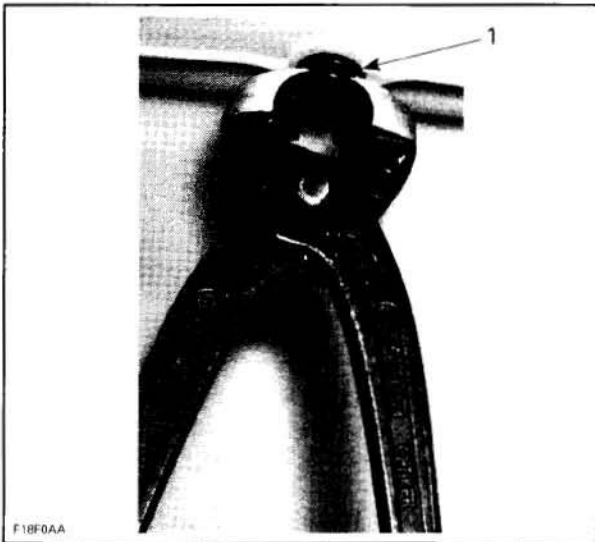

1. Dart

Disconnect multifunction connector.

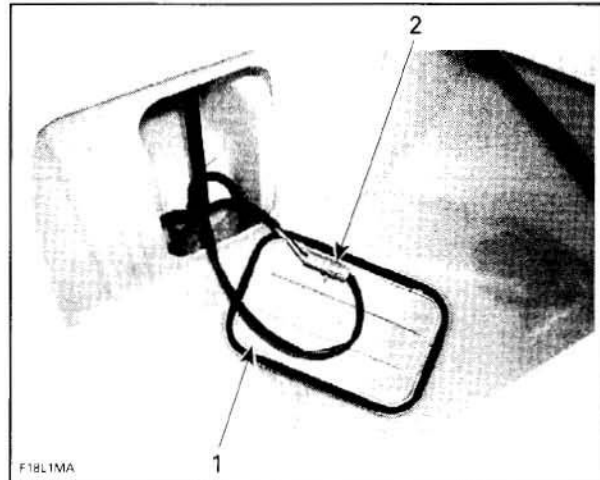

#### TYPICAL

1. Access panel
2. Multifunction connector

Unlock shock rod from circlip and remove washer.

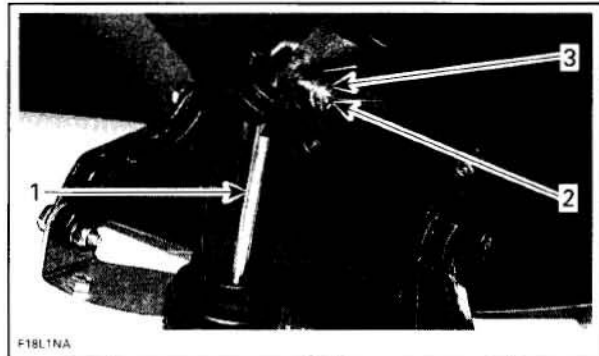

#### TYPICAL

1. Shock rod
2. Circlip
3. Washer

Remove one long retaining screw (front).

Remove two short retaining screws located in the back lower side and hold cover firmly.

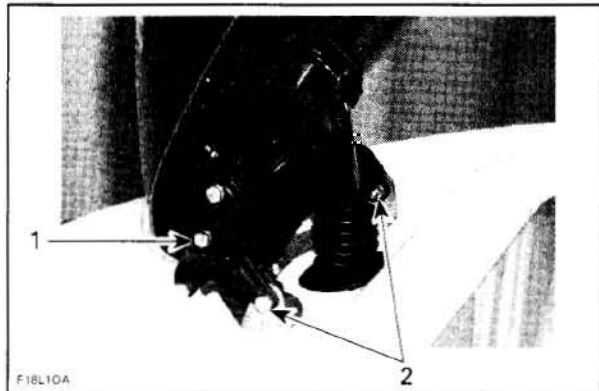

#### TYPICAL

1. One long retaining screw (front)
2. Short retaining screw (one on each side to the back)

Remove storage compartment cover.

**Installation**

The installation is the reverse of the removal procedure.

**GTI Series**

When installing screws retaining storage compartment cover, use **NEW screw with Scotch Grip**. NEVER use liquid threadlocker with this cover.

**STORAGE COMPARTMENT COVER HINGE**

**Removal**

**GTI Series**

Remove storage compartment cover, see above.

Unscrew the 5 bolts securing the hinge to the body.

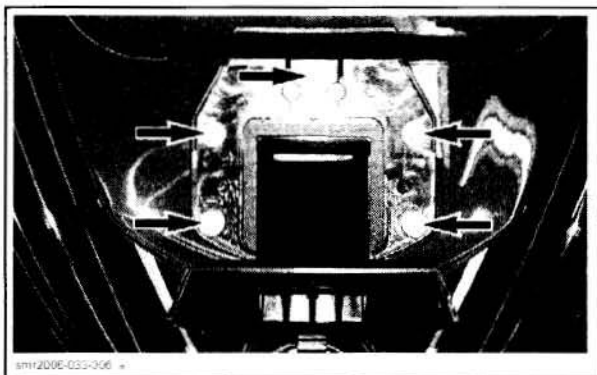

Pull hinge to remove it from body.  
Cut a push nut retaining hinge shaft.

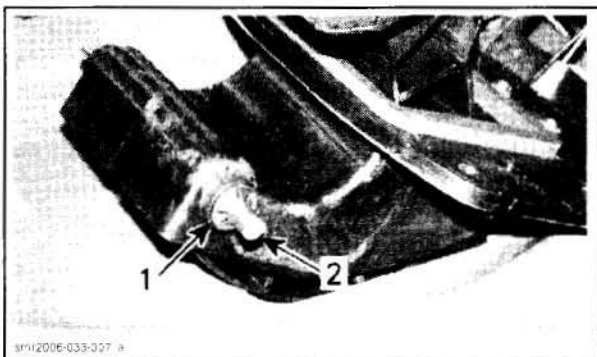

- 1. Push nut
- 2. Hinge shaft

Remove hinge shaft and separate both parts of hinge.

**Installation**

For installation, reverse the removal procedure.

**STORAGE COMPARTMENT COVER SHOCK**

**Removal**

**All Models except GTI Series**

Unlock shock rod from circlip and remove washer.

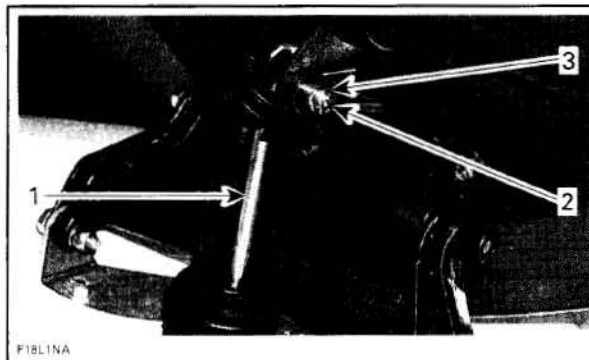

- 1. Shock rod
- 2. Circlip
- 3. Washer

Install a 2 x 4 piece of wood between storage cover and body. This piece of wood will support the storage cover while changing the cover shock.

Release the shock from top linkage bracket and bottom support bracket by inserting a flat screwdriver in the shock top and bottom locking devices.

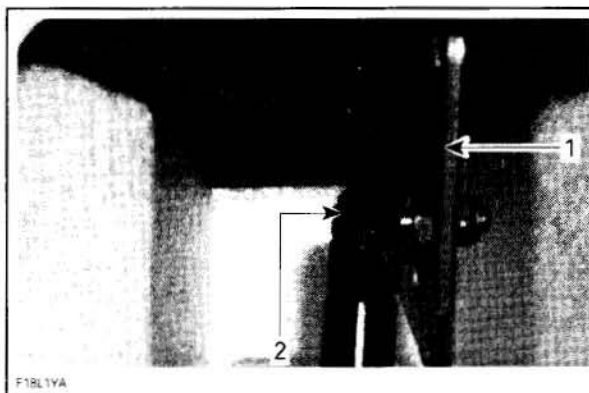

- 1. Top linkage bracket
- 2. Shock top locking device

## Section 09 HULL/BODY

### Subsection 01 (ADJUSTMENT AND REPAIR)

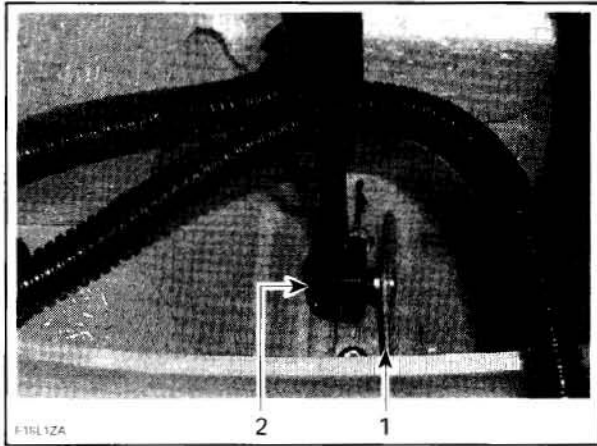

- 1 Bottom support bracket  
2 Shock bottom locking device

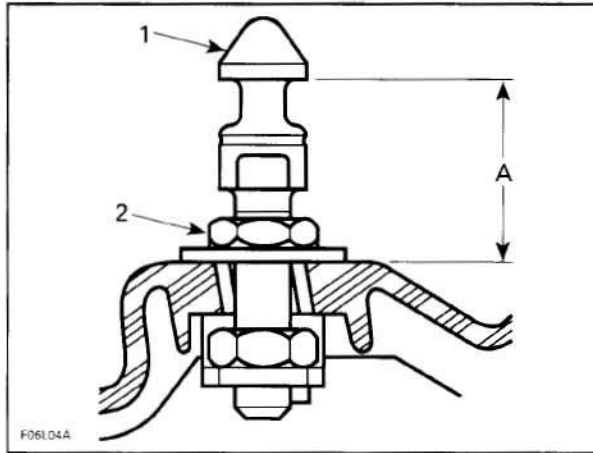

#### FIXED TYPE LOCK PIN

1. Lock pin (apply Loctite 243 on threads)  
2. Adjustment nut. Torque to 8 N•m (71 lbf•in)  
A.  $30 \pm 1$  mm (1.3/16  $\pm$  3/64 in)

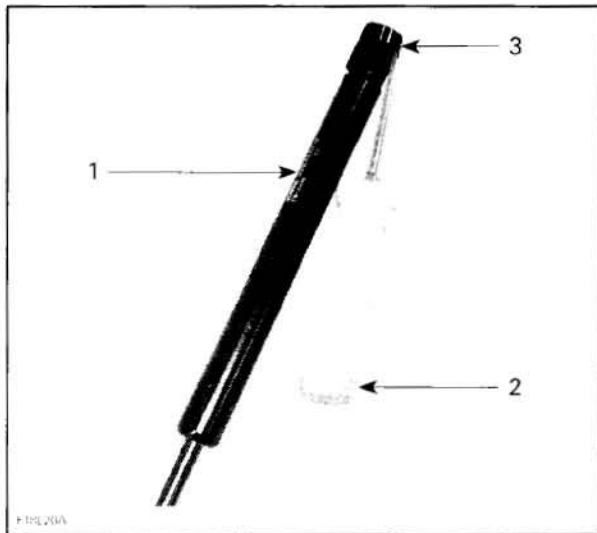

- 1 Shock absorber  
2 Flat screwdriver  
3 Shock top locking device

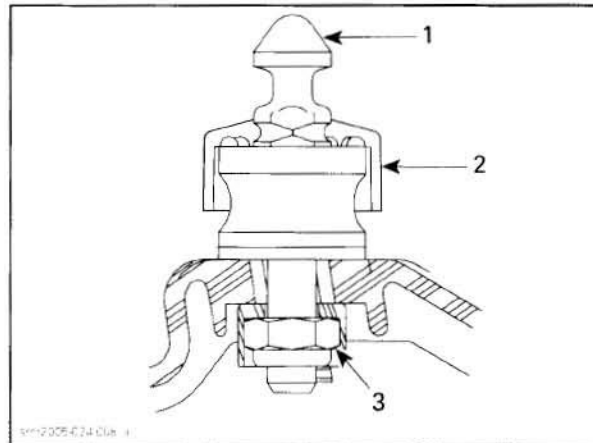

#### FLOATING TYPE

1. Lock pin (apply Loctite 243 on threads)  
2. Rubber cushion pad  
3. Lock nut. Torque to 8 N•m (71 lbf•in)

### Installation

The installation is the reverse of the removal procedure.

### STORAGE COMPARTMENT COVER LATCH

#### Adjustment

##### All Models except GTI Series

**NOTE:** Apply Loctite 243 (blue) (P/N 293 800 060) on threads of lock pin when the adjustment is required or when the lock pin is removed then reinstalled. The threads on new lock pin are coated with a self-locking product, do not apply Loctite 243 on threads.

Adjust lock pin as per following specifications:

348

**NOTE:** It is normal to have a front and aft play of the rubber cushion pad when using a floating type lock pin. To adjust, tighten lock pin until any vertical play is eliminated. Make sure a front and aft play remains when pressing by hands.

### STORAGE COMPARTMENT COVER INNER SHELL

#### Removal

##### GTX Series and RXT Models

Remove storage compartment cover. See *STORAGE COMPARTMENT COVER* above.

**CAUTION:** Failure to follow this order may lead to damaging inner plastic studs.

Remove seven inner shell short screws (flanged screws).

smr2006-033



**Section 09 HULL/BODY**  
**Subsection 01 (ADJUSTMENT AND REPAIR)**

Remove two long inner shell screws (hexagonal screws).

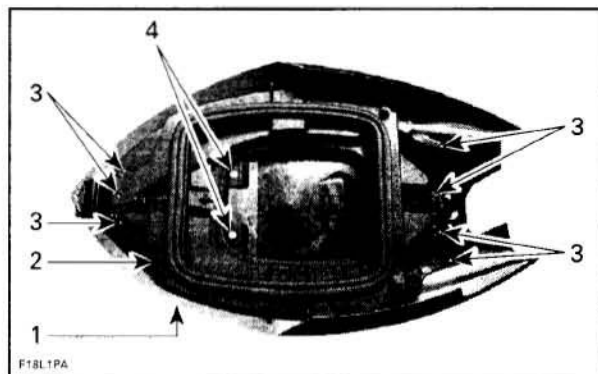

- 1. Storage cover
- 2. Inner shell
- 3. Inner shell short screws (x 7)
- 4. Inner shell long screws (x 2)

Use a rubber hammer to remove the inner shell from the cover. If the inner shell is too stiff, install a piece of 2 x 4 against the inner shell and hit it with the rubber hammer.

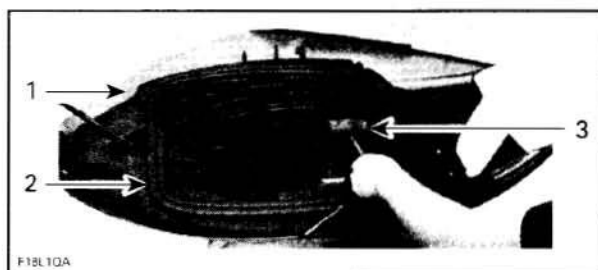

- 1. Storage cover
- 2. Inner shell
- 3. Rubber hammer

Remove connector harness from the inner shell by cutting tie raps.

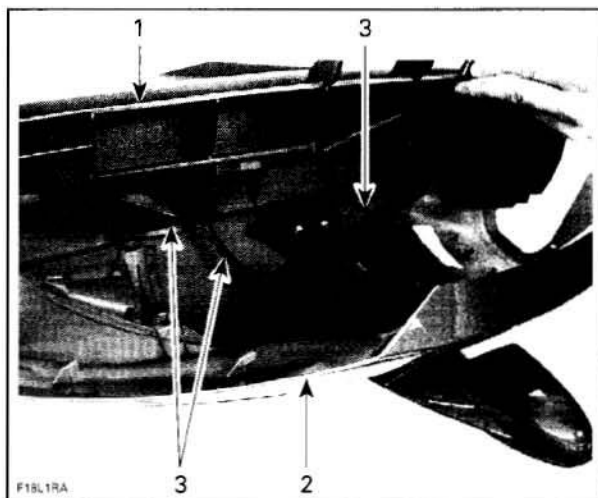

- 1. Inner shell
- 2. Storage cover
- 3. Connector harness

Remove compass by removing dart (2).  
 Remove temperature sensor from grommet.

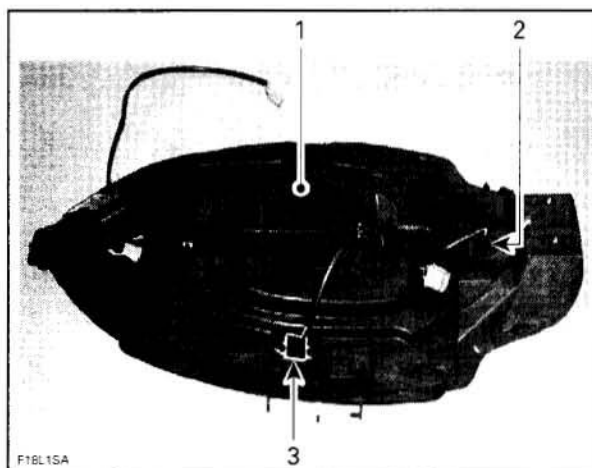

- 1. Inner shell
- 2. Temperature sensor
- 3. Compass

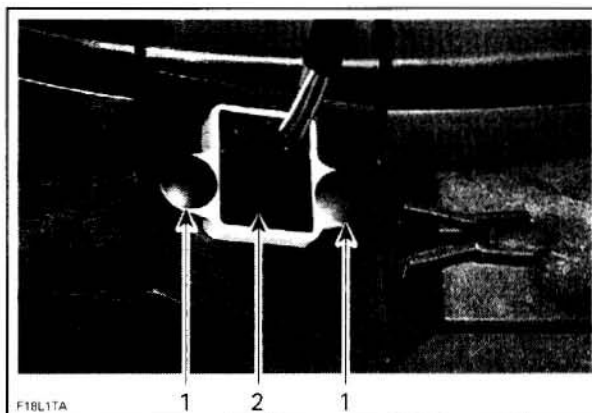

- 1. Dart (2)
- 2. Compass

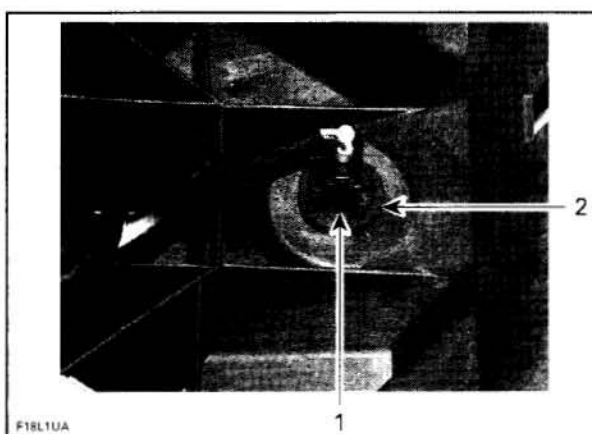

- 1. Temperature sensor
- 2. Grommet

Remove inner shell.

## Section 09 HULL/BODY

### Subsection 01 (ADJUSTMENT AND REPAIR)

#### RXP Models

Remove retaining screws from inner shell including the front screws.

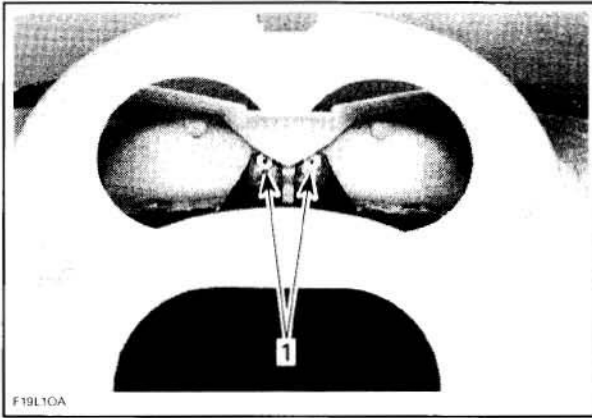

1. Front screws

Lift the end of top tubes and remove retaining screws.

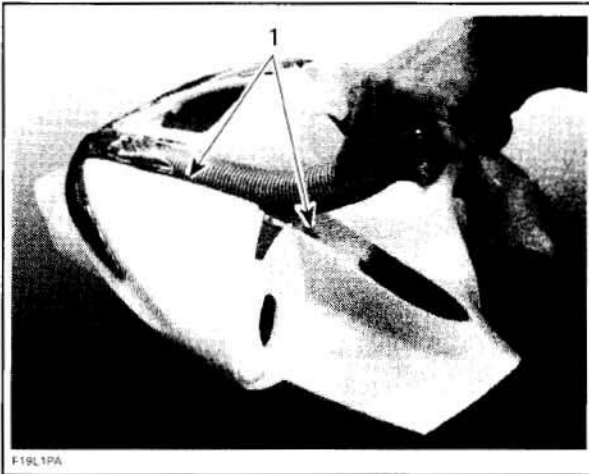

1. Retaining screws

Slide inner shell out as shown.

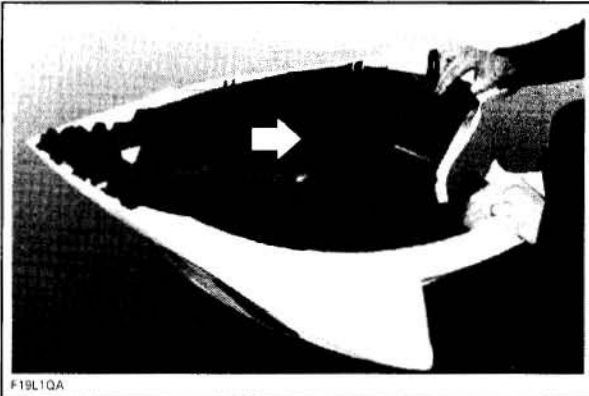

SLIDE OUT

#### Installation

##### GTX Series and RXT Models

Install new inner shell in the reverse process.

For installation, proceed as follows:

- Install the compass and secure it with the two darts.
- Install the temperature sensor in grommet.
- Install the tie raps around wire harnesses.
- Align inner shell with storage cover and make sure that the lateral locking hooks in the inner shell get engaged in the storage cover locking bracket. If the two lateral locking hooks get properly aligned and engaged the storage cover back locking hook will be engaged properly in the inner shell back locking bracket.

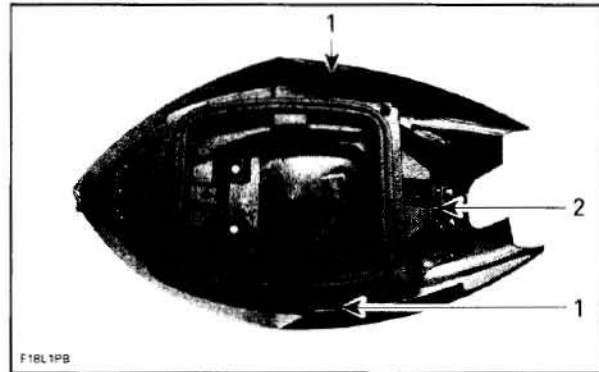

1. Inner shell lateral locking hook  
2. Inner shell back locking bracket

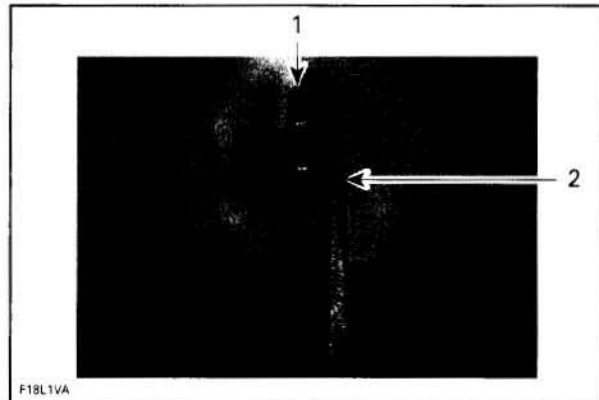

1. Storage cover lateral locking bracket  
2. Inner shell lateral locking hook

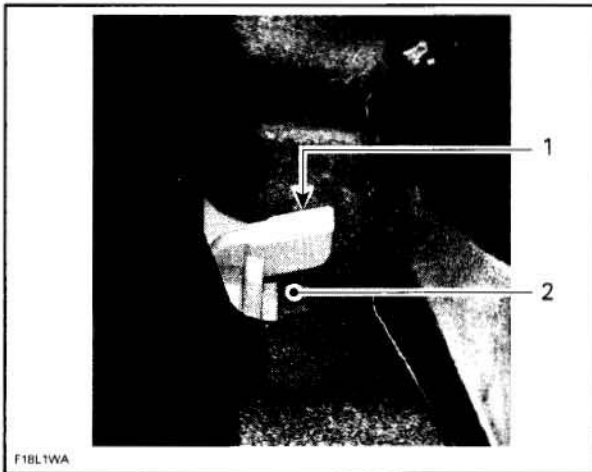

1. Storage cover back locking hook  
2. Inner shell back locking bracket

- Secure the inner shell in the storage cover by using the rubber hammer.
- Fasten the seven inner shell short screws and the two inner shell long screws.

**RXP Models**

Installation is the reverse of removal procedure. However, pay attention to the following.

Lay down inner shell in storage cover. Align inner shell slot with cover tab. Do not force inner shell forward.

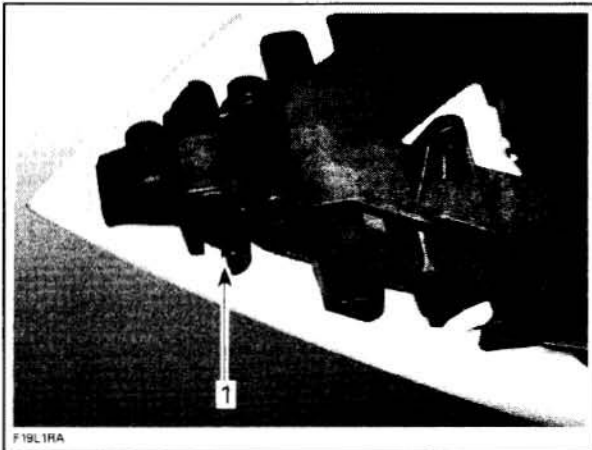

1. Align cover tab with inner shell slot

Install front screws. This will properly move inner shell forward and lock it into cover tabs.

Install top retaining screws (those located under the top tubes). Torque screws to 11 N•m (97 lbf•in).

Install remaining retaining screws of inner shell.

**FRONT GRILL OF COMPARTMENT COVER**

**RXP Models**

**Removal**

Remove inner shell.

Remove retaining screws of grill.

Carefully release the locking tabs.

**CAUTION:** Proceed with caution. Damaging the locking part of the storage cover will prevent proper retaining of the front grill after reinstallation.

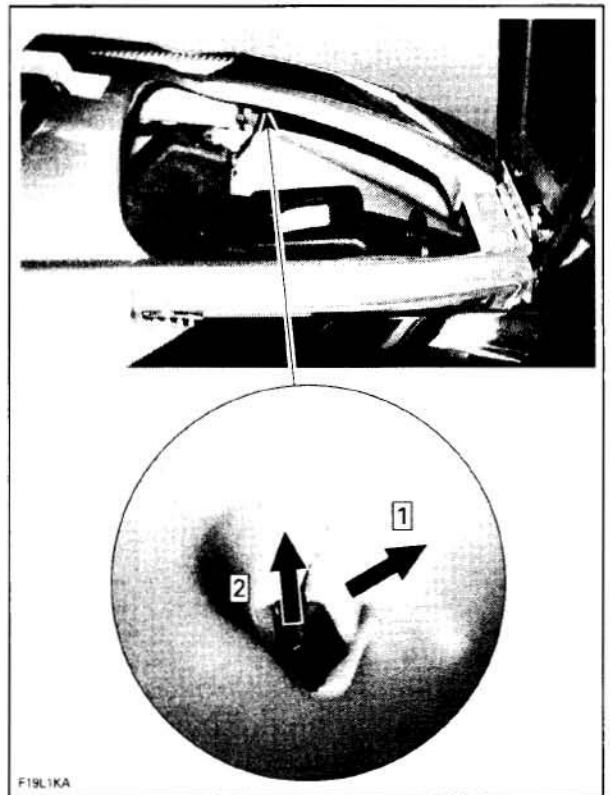

Step 1: Release the locking tab and HOLD  
Step 2: Push tab upward

- Release front part of grill and remove it.

**Installation**

At installation, first install the front part of front grill. Do not snap rear tabs yet.



## Section 09 HULL/BODY

### Subsection 01 (ADJUSTMENT AND REPAIR)

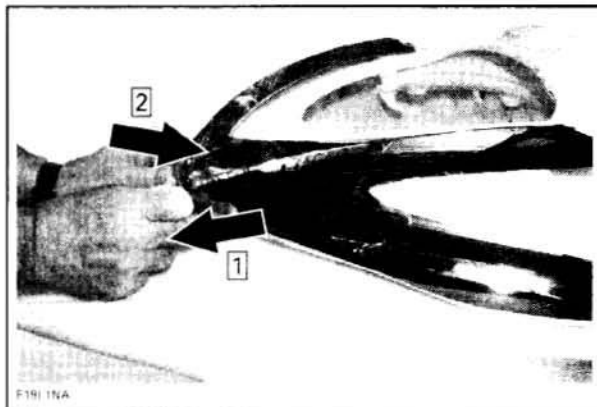

Step 1. Pull out the bottom edges by slightly twisting to hook up.  
Step 2. Push the top corner to snap in.

Ensure to properly position and secure top tubes.

Snap the other tabs of front grill.

Install screws to retain front grill.

Reinstall inner shell.

## ACCESS COVER

### Removal

#### **GTI Series**

The access cover is located on the top of console.

Pull access cover to remove it.

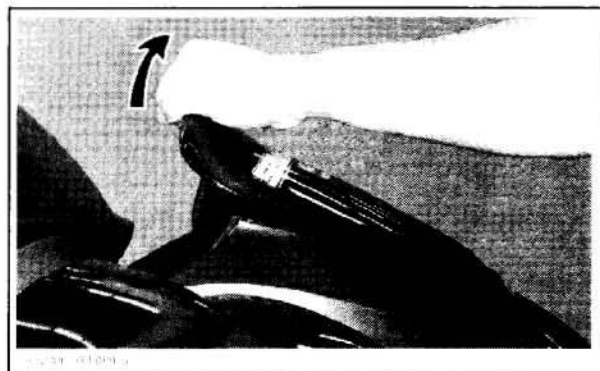

#### **RXP Models**

On this models, the access cover is located on the top of the storage compartment cover.

Press latch and lift up cover to open it.

### Installation

#### **GTI Series**

The installation is the reverse of the removal procedure.

#### **RXP Models**

When installing the access cover, adjust its locking pin. Refer to the following illustration.

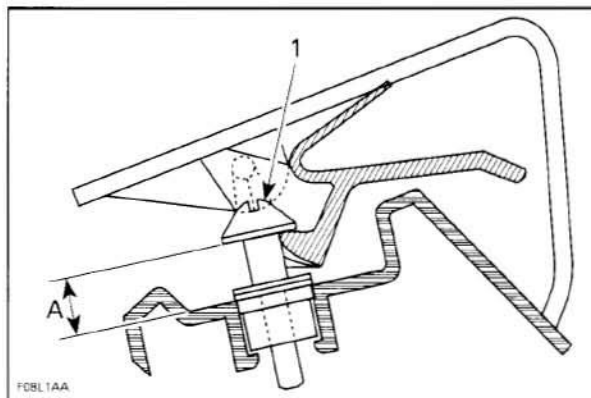

1. Access cover locking pin  
A. 12 mm ± 0.9 mm (.472 in ± .035 in)

## CONSOLE

### **GTI Series**

### Removal

Remove access cover and unplug the information center.

On **GTI SE** models, using a 8 mm Allen screw, remove the socket screw holding mirror support to steering support.

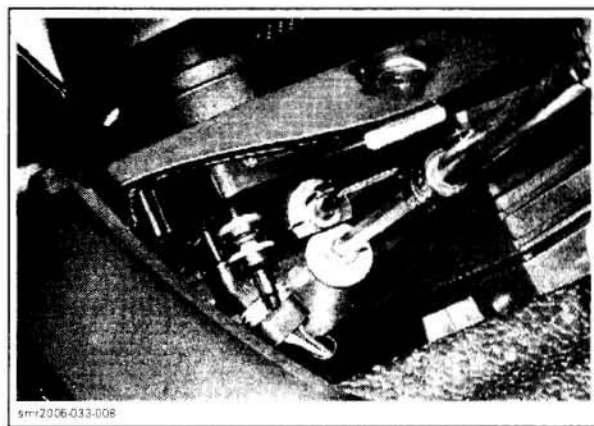

Remove shift lever handle.

**Section 09 HULL/BODY**  
**Subsection 01 (ADJUSTMENT AND REPAIR)**

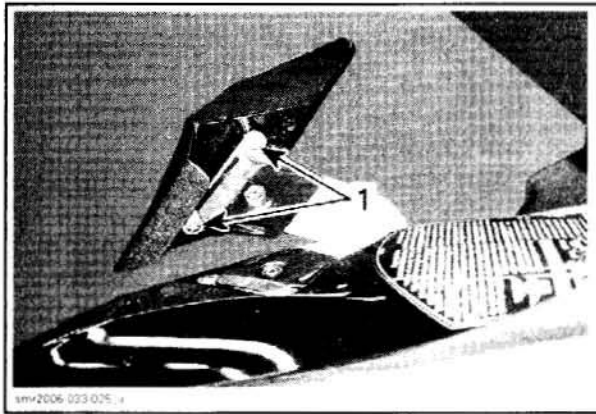

1. Shift lever handle screws

Remove glove box. Refer to *GLOVE BOX* above. Using a Supertanium™ drill bit (P/N 529 031 800), drill rivets holding console to body.

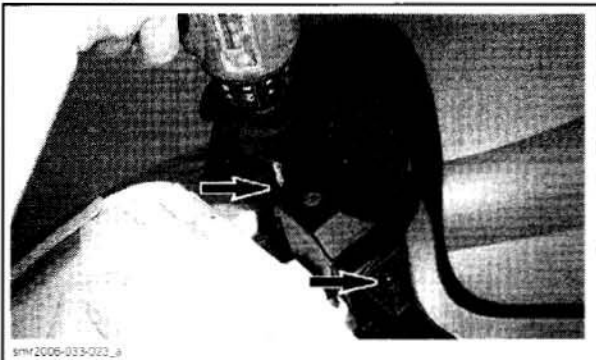
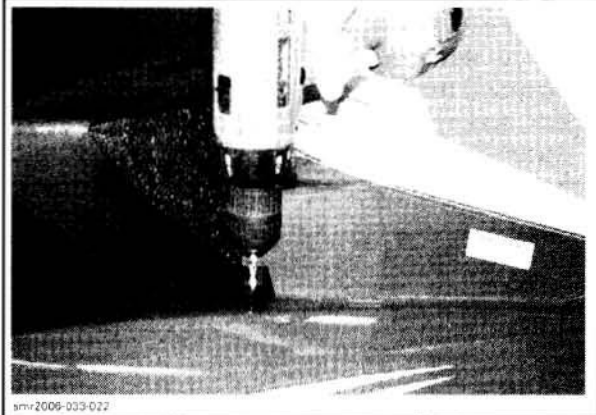
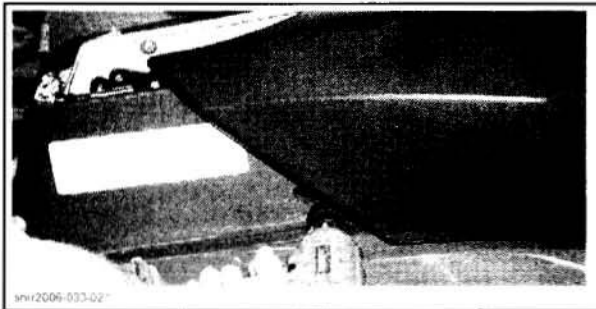

**Installation**

The installation is the reverse of the removal procedure. However, pay attention to the following.

Install console with its foam. Do not apply products such as glue or silicone, to retain foam on body or foam to console. The foam must move freely to allow a good air flow toward engine.

During installation of front rivets if a rivet does not keep console against body, use the following procedure

- On each side, using a 6 mm (15/64 in) drill bit, drill front rivet holes. Install a tip of adhesive tape over holes to avoid gelcoat damages.

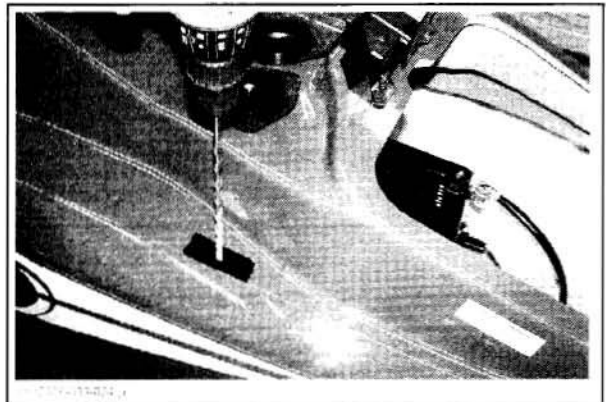

- Install the following fasteners to attach console to body.

QUANTITY	FASTENERS DESCRIPTION
2	Pan head Phillips screw M5 x 35 (P/N 208 653 560)
4	Flat washer (P/N 234 061 600)
2	Elastic stop nut M5 (P/N 232 561 600)

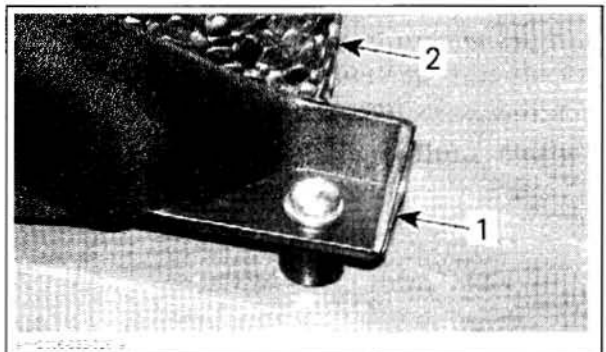

1. Console  
 2. Foam



## Section 09 HULL/BODY

### Subsection 01 (ADJUSTMENT AND REPAIR)

## MIRROR

### Removal

#### **GTI SE Models**

Remove the information center. See *GAUGE, SENSORS AND FUSES*.

Unscrew mirror bolts.

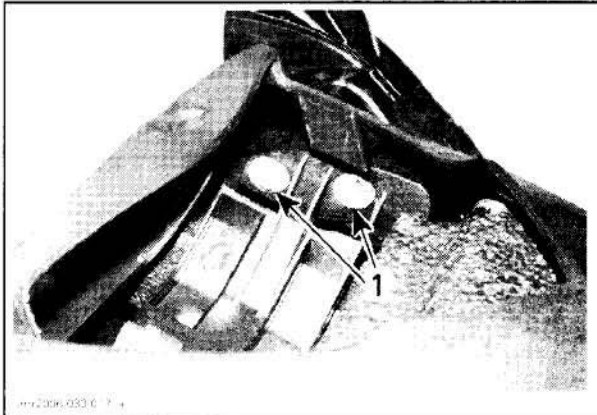

1. Left mirror bolts

Remove defective mirror with a spatula.

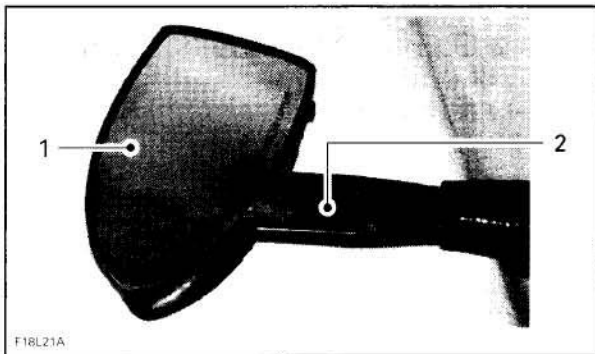

1. Mirror  
2. Spatula

#### **All Other Models**

Remove storage compartment inner shell from storage cover as described earlier in this section.

Unscrew mirror bolts and their flat washers.

Remove defective mirror with a spatula.

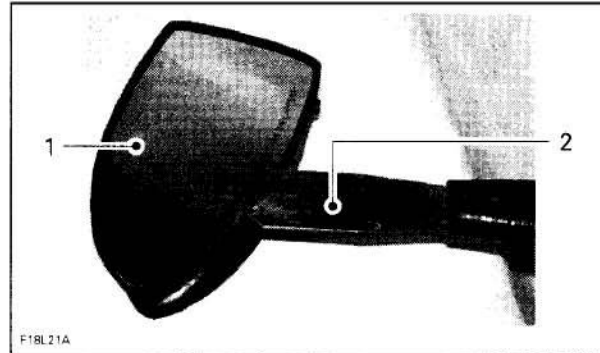

1. Mirror  
2. Spatula

### Installation

#### **All Models**

Place mirror frame in hot water to allow mirror installation in frame.

Install all removed parts.

## DEFLECTOR AND/OR UPPER GRID

### Removal

#### **GTX Supercharged Limited**

To remove the deflector and/or the upper grid proceed as follows:

- Remove storage from storage cover compartment inner shell as described earlier in this section to get access.
- Remove the defective deflector and/or the upper grid from plastic retaining clip. Use two screwdrivers to release the deflector or the grid.

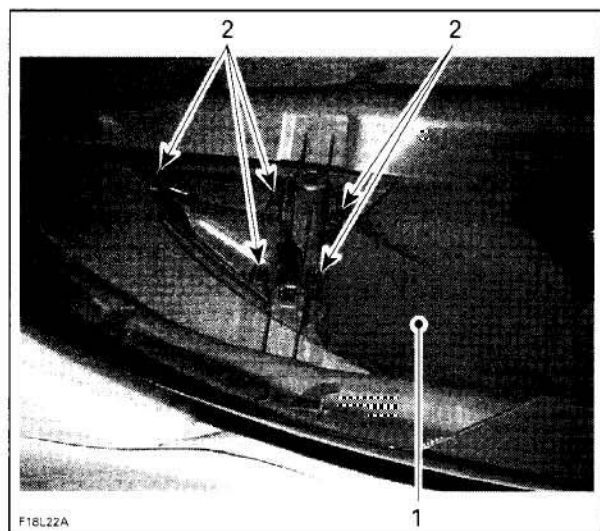

1. Inner shell  
2. Deflector retaining clips



**Section 09 HULL/BODY**  
Subsection 01 (ADJUSTMENT AND REPAIR)

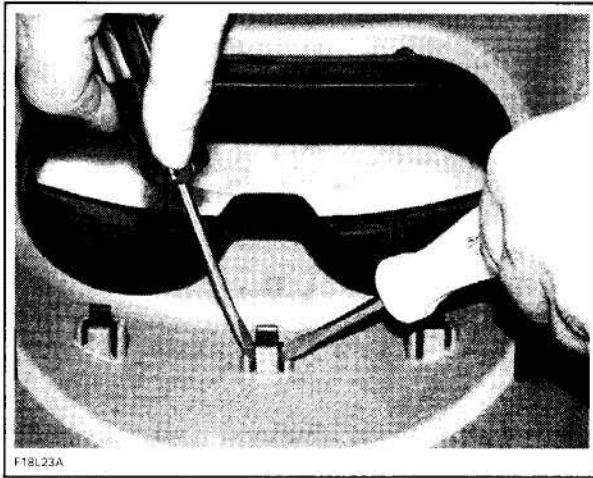

RELEASE DEFLECTOR

**Installation**

The installation is the reverse of removal procedure.

**SIDE MOLDING**

**Removal**

***GTX Series except GTX LTD***

The removal procedure for RH and LH side moldings with grills is the same.

Remove the two darts holding the grill to the body.

Make a hole into the luggage compartment as shown in the illustration below to gain access to the side molding screw.

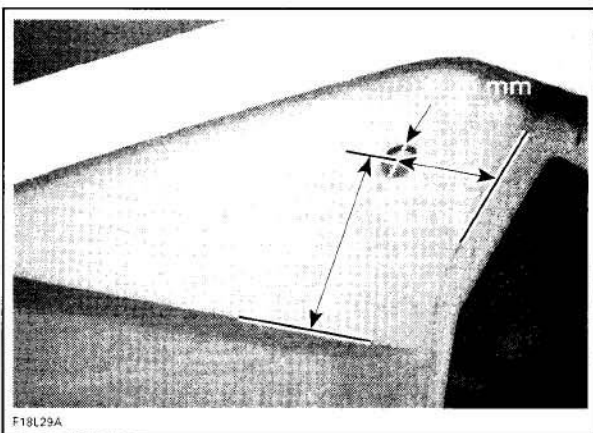

Remove screw and side molding.

***GTX Limited***

Removal procedure for RH and LH side moldings with deflector/grill is the same.

Side molding is mounted on deflector.

Remove three darts holding deflector and grill.

**Installation**

***GTX Series except GTX LTD***

After installing side molding, install a plug (P/N 291 000 279) in the side molding screw hole.

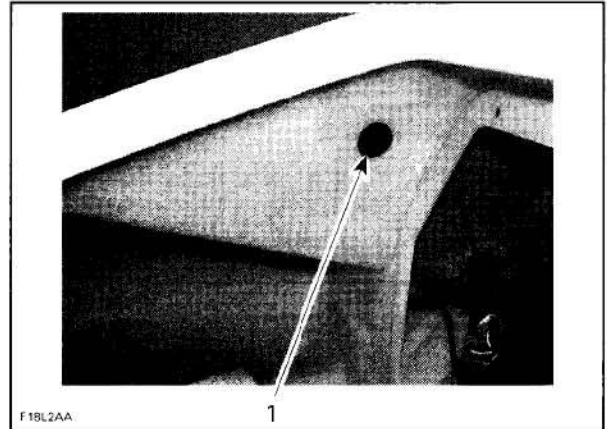

1. Plug

***GTX Limited***

The installation is the reverse of the removal procedure.

**INLET GRATE**

**Removal**

Using a heat gun, heat screws to break threadlocker.

Loosen screws and remove inlet grate.

**NOTE:** An impact screwdriver should be used to loosen screws.

**Installation**

When installing inlet grate, apply Loctite 271 (red) (P/N 293 800 005) on threads of M6 bolts.

Apply Loctite 5900 (P/N 293 800 066) on the parts of inlet grate as indicated by the shaded areas in the next illustrations.

## Section 09 HULL/BODY

### Subsection 01 (ADJUSTMENT AND REPAIR)

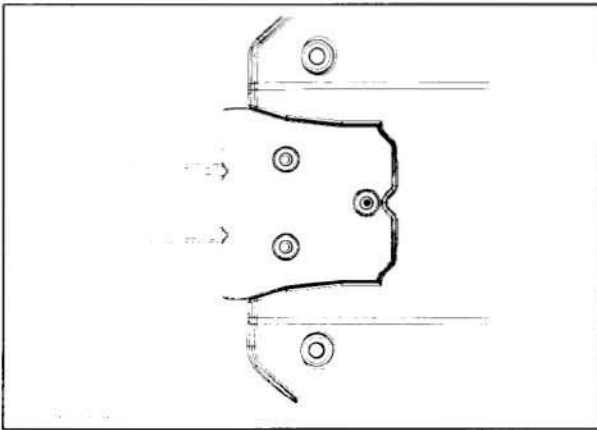
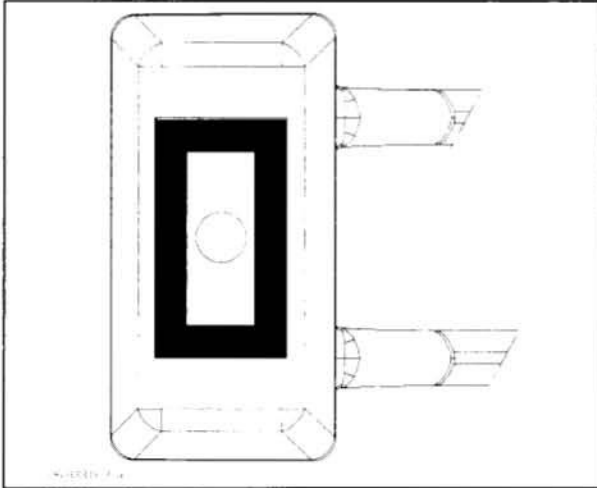

Follow this sequence referring to the illustration:  
Hand tighten screws from 1 to 4.  
Torque screw from 1 to 3 to 11 N•m (97 lbf•in).  
Torque screw 4 to 26 N•m (19 lbf•ft).

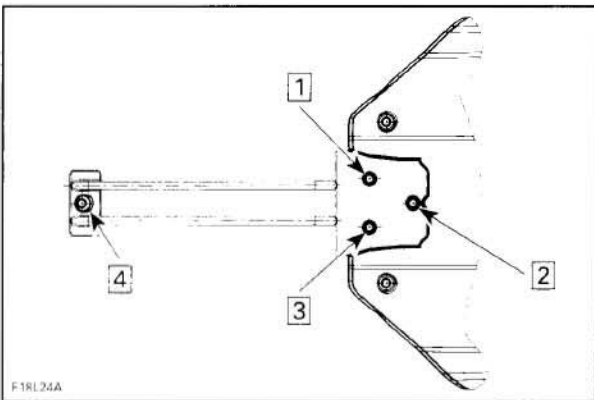

ALL MODELS EXCEPT RXP

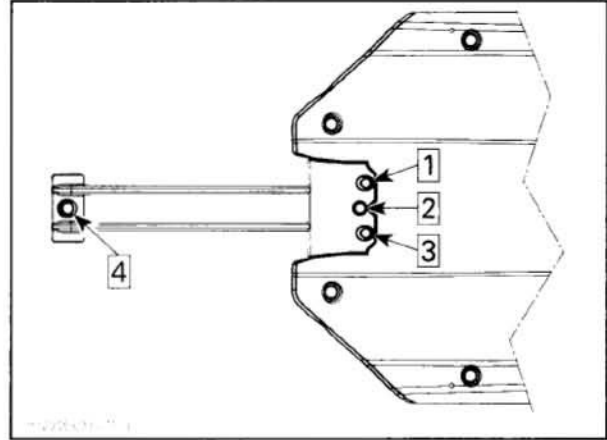

RXP MODELS

## RIDING PLATE

### Removal

Remove inlet grate.

Remove jet pump. Refer to *JET PUMP*.

Drain cooling system. Refer to *COOLING SYSTEM*.

From inside hull, disconnect hoses from ride plate.

Unscrew hose fittings from ride plate.

**CAUTION:** Removing hose fittings prior to pulling out ride plate prevents the possibility to damage fittings.

Using a heat gun, heat riding plate screws to break threadlocker then remove them.

**NOTE:** An impact screwdriver should be used to loosen screws.

Using a low height hydraulic bottle jack and 2 steel plates, pry out riding plate. Heat the riding plate with a heat gun before prying.

**Section 09 HULL/BODY**  
Subsection 01 (ADJUSTMENT AND REPAIR)

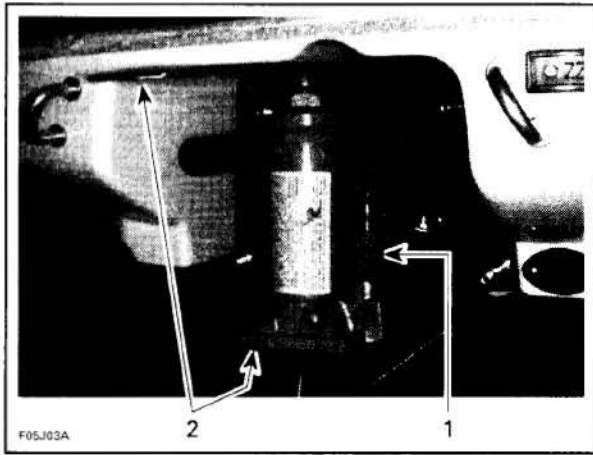

**TYPICAL**  
1. Hydraulic bottle jack  
2. Steel plates

**Cleaning**

Scrape off all excess of sealant from riding plate and hull.

Clean hull surface with acetone based solvent to eliminate grease, dust and any residue of sealant. Clean fitting threads.

**Installation**

**All Models**

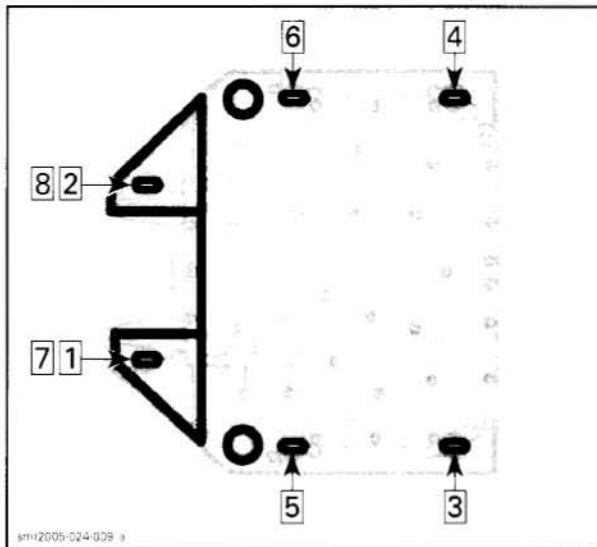

Properly reinstall hose fittings to ride plate.

Apply Loctite 5900 (P/N 293 800 066) as indicated by the shaded areas in the previous illustrations. Follow also the torquing sequence as shown in the same illustration. Torque screws to 26 N•m (19 lbf•ft).

Reinstall hoses to ride plate and refill cooling system. Refer to *COOLING SYSTEM*.

**JET PUMP SUPPORT**

**Removal**

Remove jet pump.

Remove inlet grate and riding plate.

Remove ball joint, boot, nut, half rings and O-rings from steering cable.

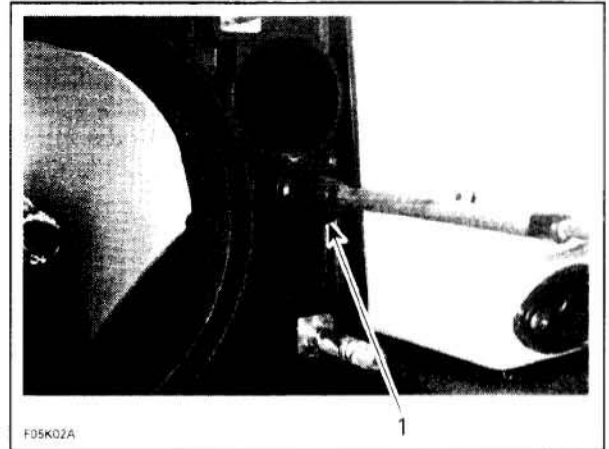

**TYPICAL**  
1. Unscrew nut

Remove ball joint, boot, nut, half rings and O-rings from reverse cable.

Remove boot and nut from VTS sliding shaft (RXP models).

Disconnect water supply hose, water return hose and bailer hoses.

Remove nuts, lock washers and flat washers retaining jet pump support.

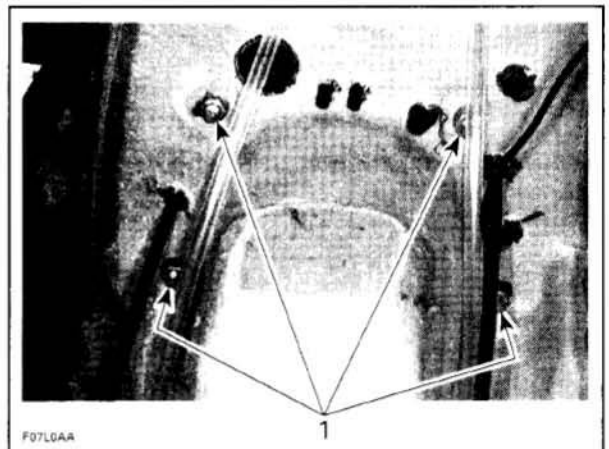

**TYPICAL**  
1. Remove nuts

Using a heat gun, heat jet pump support until it is possible to pull it.



## Section 09 HULL/BODY

### Subsection 01 (ADJUSTMENT AND REPAIR)

NOTE: Shims may have been installed between support and body. Do not remove these shims, otherwise jet pump alignment will be altered.

#### Installation

##### All Models except RXP

Apply Loctite 518 (P/N 293 800 038) against contact surface of studs with jet pump support.

##### All Models

Apply Loctite 5900 (P/N 293 800 066) as indicated by the shaded areas in the next illustrations. Follow also the torquing sequence as shown in the same illustrations. Torque to 31 N•m (23 lbf•ft).

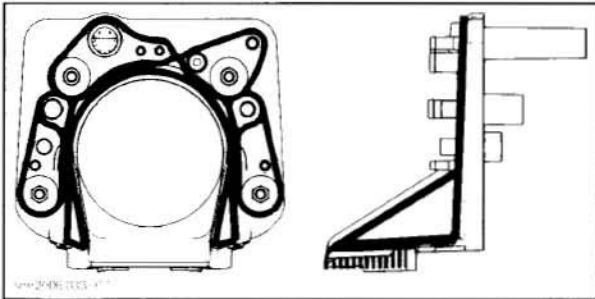

GTI SERIES, GTX SERIES AND RXT MODELS

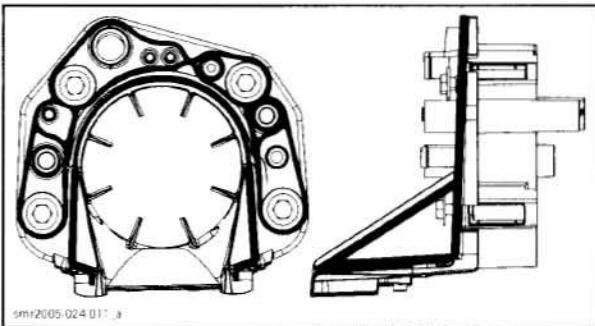

RXP MODELS

Torque jet pump support using the following sequence.

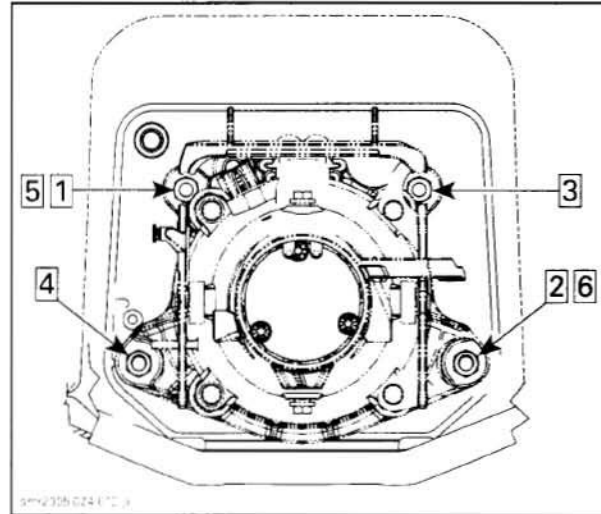

GTI SERIES, GTX SERIES AND RXT MODELS

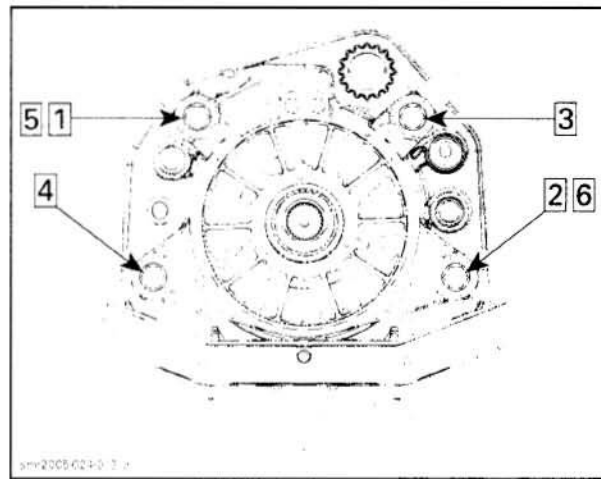

RXT MODELS

## THRU-HULL FITTING

### Replacement

Cut plastic hull insert flush with hull using a saw.

## Section 09 HULL/BODY

### Subsection 01 (ADJUSTMENT AND REPAIR)

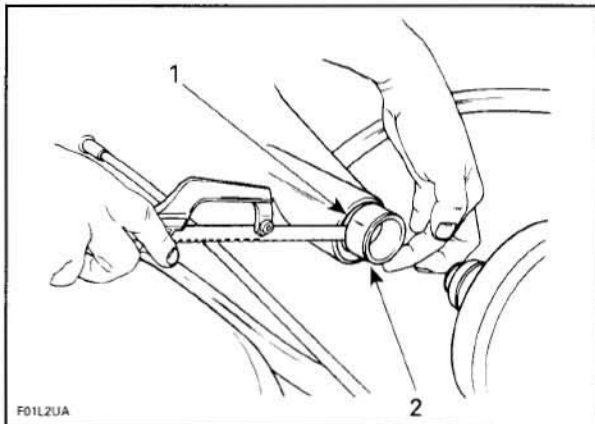

1. Hull
2. Plastic hull insert

Mix epoxy glue such as (3M-05900), follow manufacturer's instructions.

Apply epoxy glue on aluminum insert knurled surface and inside plastic insert.

Install aluminum insert into plastic insert.

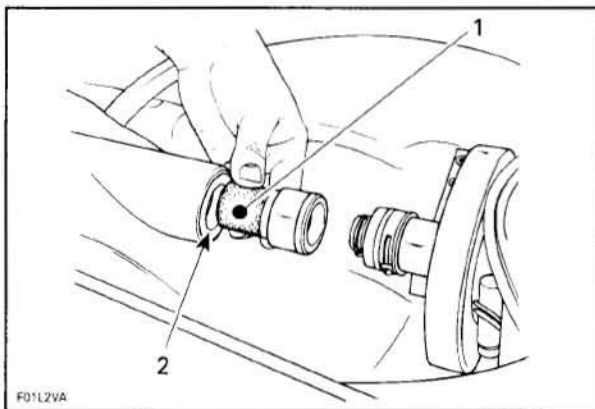

1. Knurled surface
2. Plastic insert

**CAUTION:** If you notice any clearance between plastic insert and aluminum insert, fill gap with epoxy glue to obtain good adhesion of aluminum insert.

## BUMPER

### Replacement

Remove trim from side bumper rail.

Remove screws to remove side bumper rail.

Mark hole positions on body straight and bow sections.

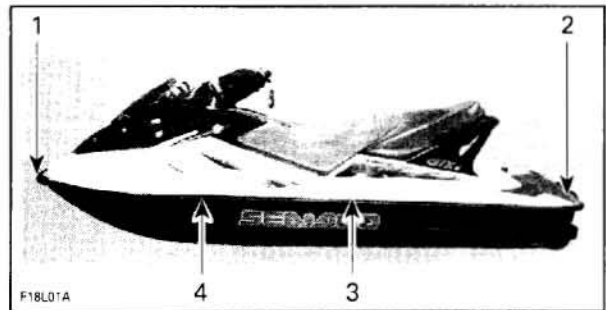

### TYPICAL

1. Front bumper
2. Corner bumper
3. Straight section
4. Bow section

Slide bumper rail under front bumper.

Using a 4.80 mm (3/16 in) drill bit, drill first hole through bumper rail at front of bow section.

**CAUTION:** When drilling, be careful not to damage bumper rail and/or hull.

Position bumper rail properly onto body and cut excess length if necessary.

Slide bumper rail in corner bumper.

Install trim using soapy water.

Repeat procedure for the other side.

## WAKE PYLON

### GTX Wake Models

### Removal

Remove the rear seat and storage basket under it. Remove nuts.

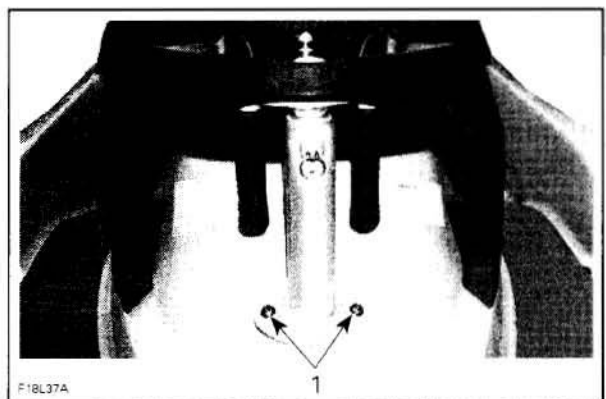

1. Screws to be removed

## Section 09 HULL/BODY

### Subsection 01 (ADJUSTMENT AND REPAIR)



1. U-clamp

Remove finition U-clamp, and screws then pull out wake post.

#### Disassembly

Loosen the stopper screw.

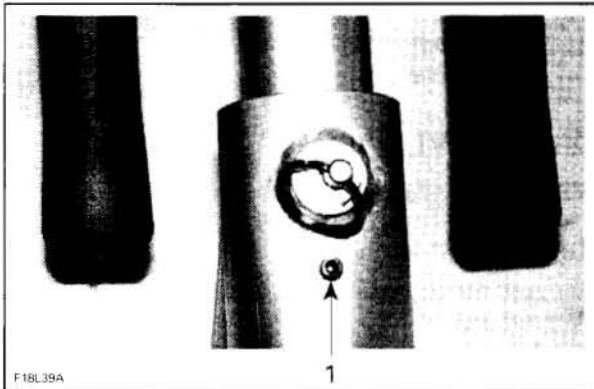

1. Stopper screw

Pull the safety lock pin to unlock and pull out the cylinder.



1. Safety lock pin

#### Assembly

Before assembly verify the physical condition of cylinder groove and adjustment holes.

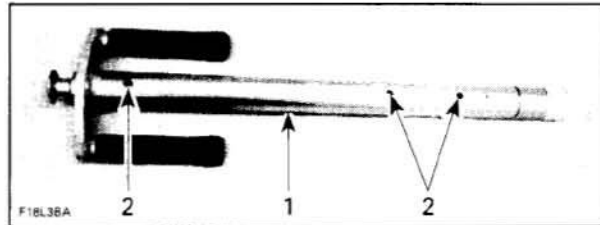

1. Groove  
2. Adjustment holes

Align groove with stopper screw, while inserting the cylinder into housing.

Tighten the stopper screw.

#### Installation

Before Installation, make sure:

- inside cylinder slides up and down freely without obstruction from grab handle
- safety lock pin operates properly
- stopper screw stops cylinder at its most upwards position.

To install the wake post, reverse removal procedure.

## SPONSON

**NOTE:** Removal and installation procedure for RH and LH sponson is the same.



## Section 09 HULL/BODY

### Subsection 01 (ADJUSTMENT AND REPAIR)

#### Removal

Unscrew sponson bolts then remove sponson.

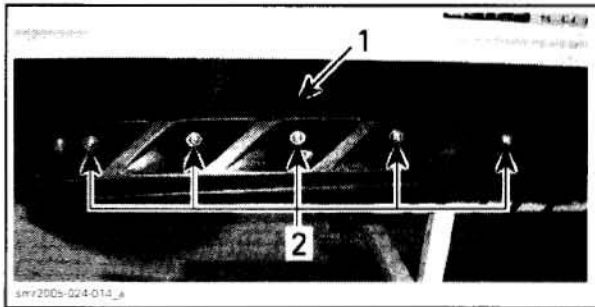

1. Sponson
2. Bolts

Clean any residues of silicone sealant on hull and sponson.

#### Installation

Apply Loctite 5150 (silicone sealant) (P/N 293 800 086) around sponson adaptors.

Apply Loctite 243 (blue) (P/N 293 800 060) on sponson bolt threads.

Install sponson and torque sponson bolts to 7 N•m (62 lbf•in).

### SPONSON ADAPTOR

**NOTE:** Removal and installation procedure for RH and LH sponson adaptor is the same.

#### Removal

Remove appropriate sponson.

Remove muffler and/or resonator. Refer to *EXHAUST SYSTEM*.

Hold sponson adaptors and unscrew sponson adaptor nuts.

Clean any residues of silicone sealant on hull and sponson.

#### Installation

Apply Loctite 243 (blue) (P/N 293 800 060) on sponson adaptor threads.

Torque sponson adaptor nuts to 16 N•m (142 lbf•in).

Install all other removed parts.

### DRAIN PLUG

#### Inspection

Inside hull, check if holes at the end of drain plug are obstructed. Clean if necessary.

Check if the hole on the elbow fitting is obstructed. Clean both elbow fittings if necessary.

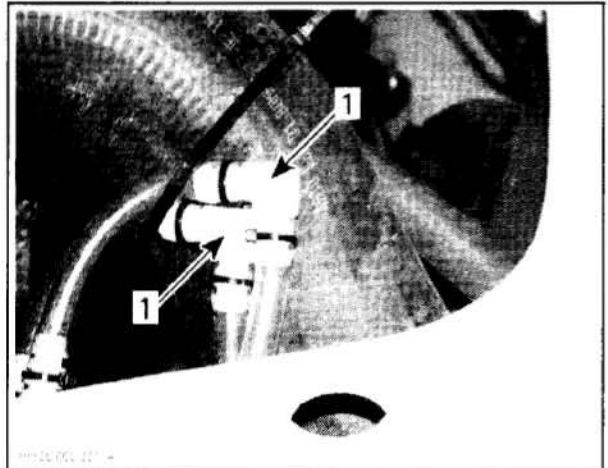

1. Elbow fitting holes

#### Removal

Remove seat.

Behind coolant tank, cut locking tie securing drain plug hoses to exhaust hose.

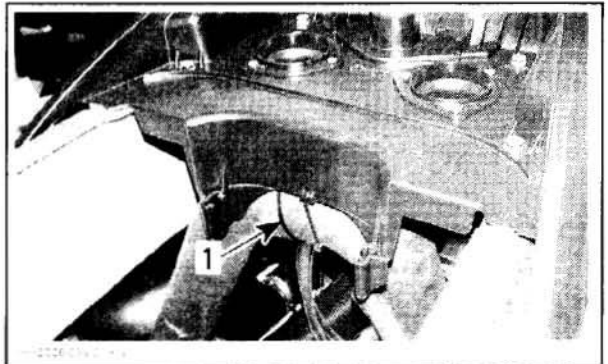

1. Cut this locking tie

Remove screws securing drain plug to hull.

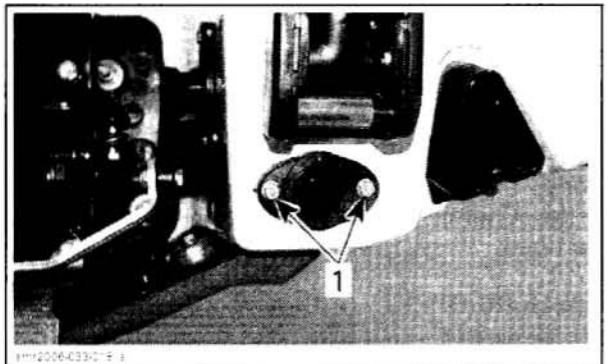

1. Drain plug screws

## Section 09 HULL/BODY

### Subsection 01 (ADJUSTMENT AND REPAIR)

#### Vinyl Cleaning Recommendations for Special Stains

TYPE OF STAIN	STEP 1	STEP 2	STEP 3	ACTION
Ballpoint ink*	E	B	A	A. Medium-soft brush, warm soapy water, rinse/dry.
Chewing gum	D	A	—	
Coffee, tea, chocolate	B	—	—	
Crayon	D	B	—	B. Vinyl Finish Cleaner, rinse/dry.
Grease	D	B	—	
Household soil	A	B	—	C. One (1) tablespoon of ammonia, one-fourth (1/4) cup of hydrogen peroxide, three-fourth (3/4) cup of water, rinse/dry.
Ketchup	A	B	—	
Latex paint	A	B	—	
Lipstick	A	B	—	
Mildew or wet leaves*	C	B	A	
Motor oil	B	—	—	D. Wipe or scrape off excess (chill gum with ice before hand).
Oil-based paint	D	B	—	
Permanent marker*	E	B	C	E. Denatured alcohol, rinse/dry.
Spray paint	B	B	—	
Suntan lotion	A	B	—	
Tar/asphalt	D	B	—	
Yellow mustard	A	B	C	

\* Suntan lotion, tree pollen, wet leaves and some other products can contain dyes that stain permanently.

All cleaning methods must be followed by a thorough rinse with warm water.

Certain household cleaners, powdered abrasives, steel wool, and industrial cleaners can cause damage and discoloration and are not recommended. Dry cleaning fluids and lacquer solvents should not be used as they will remove printed pattern and gloss. Waxes should be used with caution as many contain dyes or solvents that can permanently damage the protective coating.

Please contact G&T industries "Marine Specialties Group" hot line at 1 800 318-2887 for any cleaning and care questions.

#### BODY AND HULL

Occasionally, wash the body with water and soap (only use mild detergent). Remove any marine organisms from engine and/or hull. Apply non-abrasive wax such as silicone wax.

**CAUTION:** Never clean fiberglass and plastic parts with strong detergent, degreasing agent, paint thinner, acetone, etc.

Stains may be removed from seat with Spray-Nine® from Korkay System Ltd or the equivalent.

#### CARPET

To clean the carpets, use 3M™ Citrus Base Cleaner (24 oz spray can) or the equivalent. See the manufacturer's instructions.

#### REPAIR

##### HULL AND BODY

###### General

When servicing the hull, drain engine oil and fuel tank to avoid flowing. Rotate watercraft either way (seen from the rear) maximum to 90°.

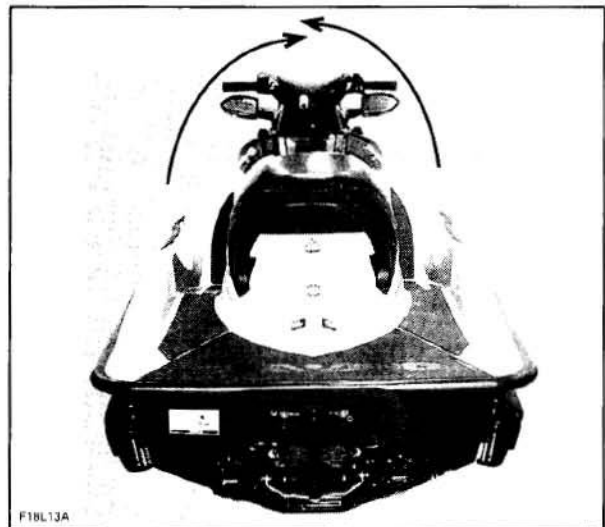

Gelcoat is the smooth and durable cosmetic finish which coats the fiberglass hull and body of a Sea-Doo watercraft. It also provides a protective barrier against water and sun. It consists of a mixture of resin, pigment (coloring), fillers, monomers and catalyst which is sprayed into the mold.

The body and hull of the Sea-Doo are constructed of chopped fiberglass, saturated with resin. It is sprayed on the layer of gelcoat along with pieces of fiberglass mat, cloth and woven roving which are added at required areas. This type of construction is very accommodating for high quality repairs. With patience, the proper techniques and materials, a damaged area can be restored to an original finish.



## Section 09 HULL/BODY

### Subsection 01 (ADJUSTMENT AND REPAIR)

**NOTE:** Fiberglass repair kit is available through automotive or marine suppliers. Gelcoat repair kits are available directly from Gelcote International Ltd.

#### **⚠ WARNING**

Protect skin, wear gloves when in contact with resin, hardeners and gelcoat. A barrier skin cream may also be used. Do not expose area to open flame or lit cigarette. Some of the materials are flammable. Protect eyes, wear safety glasses when grinding, sanding or spraying. Use a dust mask when sanding or grinding. When spraying wear a respirator or paint mask. Always read warning labels on products.

#### **Air Bubbles**

Possible cause:

- Air pocket trapped between layers of laminate and gelcoat.

#### **PREPARATION OF SURFACE**

Remove all of the damaged gelcoat surrounding the air bubble with a putty knife or preferably a carbide grinding tip. Make sure all loose and weak areas are completely removed. Sand a small area of the gelcoat surface with 220-grit sandpaper. If needed, sand the cavity itself. These areas must have a rough surface to allow the gelcoat putty to bond properly.

#### **FILLING THE CAVITY**

The prepared surface must be cleaned with acetone on a cloth. Use a gelcoat repair kit. Follow the mixing instructions in the kit when preparing the gelcoat putty.

Carefully mix the required amount while making sure there are no air bubbles in the mixture. With a putty knife, fill the repair area and cover with plastic film. Curing time may depend on temperature, amount of putty and percentage of catalyst. After 2 hours, press lightly on the surface with fingers to test the hardness. When the area becomes hard, remove the plastic film.

#### **SANDING**

Begin block sanding the patch with 320-grit sandpaper until you come close to the original surface. Remove dust with a water soaked cloth and continue sanding with a 400-grit wet paper. Finish wet sanding with a 600-grit to remove deeper scratches. If needed you can wet sand with finer grit paper such as 1000-grit.

#### **BUFFING AND WAXING**

Buff the surface using a heavy duty polisher with a buffing pad. Make sure the pad is free of dirt or you may damage the gelcoat. Carefully begin buffing with a white medium compound. Finish off using a fine compound. While buffing, pay close attention to avoid overheating the surface.

#### **Blisters**

Possible causes:

- Insert catalyst.
- Improper catalyst/gelcoat ratio.

A blister is a visible bump on the watercraft surface that may not necessarily come right through the gelcoat layer. In the case of only a few blisters, follow the same repair procedure as for air bubbles. If they are numerous and in close concentration, spray liquid gelcoat to achieve proper repair. This procedure is covered in *MINOR GELCOAT FRACTURES*.

#### **Minor Gelcoat Fractures**

Possible causes:

- Flexing of fiberglass laminate.
- Gelcoat thickness.
- Direct result of impact.

In case of fractures which have not penetrated past the gelcoat layer, the repair concerns the gelcoat only. If flex cracking or impact are evident, then additional reinforcement may be necessary. This subject will be covered in *COMPOUND FRACTURES*.

#### **PREPARING THE SURFACES**

##### **Small Fractures**

Open the cracks up with a sharp triangular can opener or preferably a carbide tipped die grinder. The V groove will provide a good bonding area for the gelcoat. With 220-grit sandpaper, sand the sides of the notched out areas.

##### **Numerous Fractures**

Using a grinder with a 24-grit disk, remove the gelcoat. Sand the area edge with 220-grit sandpaper.

#### **FILLING THE REPAIR AREA**

##### **Small Fractures**

Refer to the same procedure as in the *AIR BUBBLES*.



### **Numerous Fractures Over Large Surface:**

Prepare the area for spray application of liquid gelcoat. Wipe down the surface with acetone. Mask the area off to protect the watercraft from overspray.

Mix the needed quantity of gelcoat and catalyst according to suppliers recommendations. The gelcoat can be thinned with acetone up to 10%. If it needs more consistency you can add cabosil.

Make sure that the air supply is free of oil, dirt and water.

Test spray the gelcoat mixture on paper to verify its consistency and pattern. You may have to apply 5 or 6 coats to cover the area properly. Overlap each coat further than the last, leaving at least 30 seconds between passes. Avoid trying to coat the surface with only a few heavy coats, this will not allow the gelcoat to dry properly.

Apply a coat of polyvinyl alcohol (PVA) to seal off the air and protect the gelcoat surface from dust. PVA speeds up the curing process because gelcoat will not cure properly when exposed to air.

### **SANDING**

Wash the polyvinyl alcohol off with water. Depending on the size of the area repaired, you can either block sand as per previous procedure or you may use an air sander. Sand the surface down with progressively finer grits of sandpaper until the desired finish is achieved.

### **BUFFING AND WAXING**

Buff the surface using a heavy duty polisher with a buffing pad. Make sure the pad is free of dirt or you may damage the gelcoat. Carefully begin buffing with a white medium compound. Finish off using a fine compound. While buffing, pay close attention to avoid overheating the surface.

### **Compound Fractures**

Possible causes:

- Thickness of fiberglass laminate.
- Direct result of impact.

Compound fractures are those that have gone past the gelcoated surface and in through the layers of fiberglass laminate. Two types of repairs have to be performed. The first is to restore the structural integrity of the damaged area. Fracture types can vary from a simple crack to a large hole. Usually, fiberglass reinforcement becomes necessary, especially if the fracture can be attributed to weakness. The final part of the repair is the gelcoating, which cannot be done until the interior and exterior laminate surfaces have been repaired.

### **Outside**

Remove the damaged gelcoat and fiberglass with a 24-grit disk using a power sander. Grind outward at least 2 inches from the fracture to allow the patch to bond to strong material. Cut enough pieces of fiberglass mat necessary to build up the area. The pieces should be cut so they overlap each other by at least a half inch. For a smoother finish, the last layer should be fiberglass cloth. If the fracture is small enough all you may have to do is fill the area with an epoxy filler.

### **Inside**

For the interior repair, you can grind more. This will allow for more fiberglass material which will strengthen the area. If the fracture opening is too large after surface preparation, you may need a backing support to cover the opening. Cut alternating pieces of fiberglass mat and cloth in overlapping sizes.

### **PATCHING THE REPAIR AREA**

#### **Outside**

The outside should be done first. Wipe clean the area with acetone on a cloth, then mask off area. For a small crack use an epoxy filler in the same way you would use gelcoat repair putty. When laying up a larger area you will use mat, cloth and fiberglass resin and catalyst. Use a clean container to mix the resin, mix only what you will need. Follow the recommended catalyst ratio.

Using a clean paintbrush, brush the mixed resin on the surface. Place the smallest piece of mat over the fracture and then wet out the mat. Follow with the remaining pieces of mat and final layer of cloth. While wetting the pieces make sure you work the air bubbles out and saturate all the pieces evenly. Try to work quickly, you may only have 15 or 20 minutes. You may clean the brush with acetone.

---

## Section 09 HULL/BODY

### Subsection 01 (ADJUSTMENT AND REPAIR)

---

Wait until the repair has hardened before moving on to the interior repair. If the size of the opening is too large for the pieces to maintain the proper shape, you will have to use a backing support. It is a shaped piece of cardboard that fits flush to the interior surface and has a plastic layer on the repair side. It is held in place by tape or a support.

#### Inside

Wipe down the area with acetone on a cloth. Apply the same procedure as for outside repair when laminating the alternating pieces of fiberglass material. If a backing support was used, remove it before starting the repair. After the area has hardened, remove sharp edges of material from surface. If required paint the surface.

#### SANDING

##### Outside

This surface will have to be prepared for application of gelcoat. The size of the area will determine the gelcoating procedure to be used. Refer to the *REPAIR PROCEDURE FOR MINOR GELCOAT FRACTURES*.

#### BUFFING AND WAXING

Refer to the *BUFFING AND WAXING FOR MINOR GELCOAT FRACTURES*.

## TOOLS AND MATERIALS LIST

### Tools

- safety glasses
- air mask
- white cloths
- sanding block
- putty knife
- plastic film
- stirring stick
- cover sheets (for Sea-Doo)
- scissors
- buffing pad
- heavy-duty polisher
- power sander
- paint brush
- plastic squeegee
- spray gun
- plastic container (mixing).

### Materials

- fiberglass mat
- fiberglass cloth
- polyester resin
- cardboard
- gelcoat putty
- masking tape
- fine compound (white)
- sandpaper (100-grit, 220-grit, 320-grit, 400-grit, 600-grit, 1000-grit)
- liquid gelcoat
- acetone
- cabosil
- epoxy filler
- wax
- 24-grit sanding disks
- medium compound (white).

**Section 10 TECHNICAL SPECIFICATIONS**  
Subsection 01 (GTI AND GTI SE)

## GTI AND GTI SE

MODEL		GTI	GTI SE
<b>ENGINE</b>			
Engine type		ROTAX® 1503 4-TEC, 4-stroke, Single Over Head Camshaft (SOHC)	
Induction		Naturally aspirated	
Number of cylinders		3	
Number of valves		12 valves with hydraulic lifters (no adjustment)	
Bore	Standard	100 mm (3.9 in)	
	1 <sup>st</sup> Oversize	100.25 mm (3.95 in)	
Stroke		63.4 mm (2.49 in)	
Displacement		1493.8 mm <sup>3</sup> (58.81 in <sup>3</sup> )	
Compression ratio		10.6:1	
Maximum HP RPM		7300 ± 50 RPM	
Lubrication	Type	Dry sump (2 oil pumps). Replaceable oil filter. Water-cooled oil cooler	
	Oil type	10W40 4-stroke oil (API service classification SL, SJ or SH)	
Intake valve opening		10° BTDC	
Intake valve closing		50° ABDC	
Exhaust valve opening		50° BBDC	
Exhaust valve closing		10° ATDC	
Valve stem diameter	Intake	New	5.961 to 5.975 mm (.2347 to .2352 in)
		Wear limit	5.930 mm (.2330 in)
	Exhaust	New	5.946 to 5.960 mm (.2341 to .2346 in)
		Wear limit	5.930 mm (.2330 in)
Valve guide diameter		New	5.99 to 6.01 mm (.2358 to .2366 in)
		Wear limit	6.060 mm (.2386 in)
Valve spring free length	Inner	New	41.02 mm (1.615 in)
		Wear limit	38.8 mm (1.499 in)
	Outer	New	45.45 mm (1.789 in)
		Wear limit	43 mm (1.693 in)
Valve seat contact width	Intake	New	1.1 to 1.3 mm (.043 to .051 in)
		Wear limit	1.6 mm (.063 in)
	Exhaust	New	1.25 to 1.55 mm (.049 to .061 in)
		Wear limit	1.8 mm (.071 in)
Rocker arm bore diameter		New	20.00 to 20.02 mm (.7874 to .7882 in)
		Wear limit	20.03 mm (.7886 in)
Rocker arm shaft diameter		New	19.98 to 19.99 mm (.7866 to .7870 in)
		Wear limit	19.96 mm (.7858 in)



**Section 10 TECHNICAL SPECIFICATIONS**  
**Subsection 01 (GTI AND GTI SE)**

MODEL		GTI	GTI SE
<b>ENGINE (con'd)</b>			
Cylinder head screw		Service limit	148.5 mm (5.846 in)
Cylinder head maximum warpage		Service limit	0.15 mm (.006 in)
Piston ring type and quantity		1 <sup>st</sup>	Upper compression ring, rectangular
		2 <sup>nd</sup>	Lower compression ring, tapered face
		3 <sup>rd</sup>	Oil scraper ring
Ring end gap	Rectangular	New	0.3 to 0.5 mm (.012 to .020 in)
	Taper-face		0.3 to 0.5 mm (.012 to .020 in)
	Oil scraper ring		0.3 to 0.5 mm (.012 to .020 in)
	All	Wear limit	1.0 mm (.039 in)
Ring/piston groove clearance	Rectangular	New	0.02 to 0.07 mm (.0008 to .0028 in)
	Taper-face		0.015 to 0.06 mm (.0006 to .0024 in)
	Oil scraper ring		0.02 to 0.055 mm (.0008 to .0021 in)
	All	Wear limit	0.15 mm (.006 in)
Piston/cylinder wall clearance		New	0.024 - 0.056 mm (.001 - .0022 in)
		Wear limit	0.1 mm (.0039 in)
Cylinder taper		Wear limit	0.1 mm (.0039 in)
Cylinder out of round (maximum)			0.015 mm (.0006 in)
Camshaft bearing journal	Front	New	24.93 to 24.96 mm (.9815 to .9827 in)
		Wear limit	24.93 mm (.9815 in)
	PTO and center	New	39.89 to 39.9 mm (1.5705 to 1.5709 in)
		Wear limit	39.88 mm (1.5701 in)
Camshaft bore	Front	New	25.00 to 25.01 mm (.9842 to .9846 in)
		Wear limit	25.02 mm (.9850 in)
	PTO and center	New	40.00 to 40.01 mm (1.5748 to 1.5752 in)
		Wear limit	40.02 mm (1.5756 in)
Cam lobe	Intake	New	31.48 to 31.68 mm (1.2394 to 1.2472 in)
		Wear limit	31.43 mm (1.2374 in)
	Exhaust	New	31.55 to 31.75 mm (1.2421 to 1.2499 in)
		Wear limit	31.65 mm (1.2461 in)
Crankshaft deflection		Maximum	0.050 mm (.002 in)
Crankshaft axial clearance		New	0.08 to 0.22 mm (.0031 to .0087 in)
		Wear limit	0.35 mm (.014 in)
Crankshaft journal diameter		New	49.991 to 50.000 mm (1.9681 to 1.9685 in)
		Wear limit	49.950 mm (1.9665 in)
Crankshaft radial clearance		Wear limit	0.007 mm (.0028 in)
Connecting rod big end diameter		Service limit	45.080 mm (1.7740 in)
Connecting rod big end clearance		Service limit	0.09 mm (.0039 in)
Connecting rod big end axial play		New	0.135 to 0.287 mm (.0053 to .0113 in)
		Wear limit	0.500 mm (.0197 in)
Connecting rod small end diameter		New	23.010 to 23.020 mm (.9059 to .9063 in)
		Wear limit	23.070 mm (.9080 in)

**Section 10 TECHNICAL SPECIFICATIONS**  
Subsection 01 (GTI AND GTI SE)

MODEL		GTI	GTI SE
<b>ENGINE (con'd)</b>			
Piston pin diameter	New	22.99 to 23.000 mm (.9051 to .9055 in)	
	Wear limit	22.980 mm (.9047 in)	
Piston pin bore clearance	Wear limit	0.080 mm (.0035 in)	
Balance shaft journal diameter	New	31.98 to 32.000 mm (1.2591 to 1.2598 in)	
	Wear limit	31.950 mm (1.2579 in)	
Balance shaft radial clearance	Wear limit	0.07 mm (.0028 in)	
Balance shaft axial clearance	New	0.02 to 0.25 mm (.0008 to .0098 in)	
<b>ENGINE COOLING SYSTEM</b>			
Type		Closed loop cooling system	
Coolant		Ethylene-glycol and distilled water (50%/50%). Use premix coolant from BRP or a coolant specially formulated for aluminum engines	
Thermostat		87°C (188°F)	
Monitoring beeper setting		100°C (212°F)	
<b>EXHAUST SYSTEM</b>			
Type		Water cooled/water injected (opened loop). Direct flow from jet pump	
<b>ELECTRICAL SYSTEM</b>			
Magneto generator output		380 W @ 6000 RPM	
Ignition system type		DI (Digital Induction)	
Ignition timing		Not adjustable	
Spark plug	Make and type	NGK DCPR8E	
	Gap	0.7 - 0.8 mm (.028 to .031 in)	
Generating coil		N.A.	
Battery charging coil		0.1 - 1.0 Ω	
Ignition coil	Primary	0.85 - 1.15 Ω	
	Secondary	9.5 - 13.5 kΩ	
Engine RPM limiter setting		7650 RPM	
Battery		12 V, 30 A•h	
Fuse	Accessories	2 A - 5 A	
	Battery	30 A	
	Cylinder 1, ignition coil and injection	10 A	
	Cylinder 2, ignition coil and injection	10 A	
	Cylinder 3, ignition coil and injection	10 A	
	Electric bilge pump (optional)	3 A	
	Starting system, electric fuel pump	10 A	
	EMS, start/stop circuit	5 A	
	Main	30 A	
	MPEM	2 A	
	Charging system	30 A	
	Information center	1 A	
	VTS	7.5 A (installed but not in use)	

## Section 10 TECHNICAL SPECIFICATIONS

### Subsection 01 (GTI AND GTI SE)

MODEL		GTI	GTI SE
<b>FUEL SYSTEM</b>			
Fuel injection type		Rotax EMS (engine management system) Multipoint Fuel Injection. Single throttle body (52 mm)	
Fuel pressure		290 - 310 kPa (42 - 45 PSI)	
Fuel type	Inside North America	Unleaded gasoline with a minimum of 87 octane (RON + MON)/2	
	Outside North America	Unleaded gasoline with a minimum of 91 octane RON	
Idle speed		1750 ± 50 RPM (NOT ADJUSTABLE)	
<b>PROPULSION SYSTEM</b>			
Jet pump type		Axial flow single stage	
Jet pump grease type		Bearing grease (P/N 293 550 032)	
Impeller rotation (seen from rear)		Counterclockwise	
Transmission		Direct drive	
Coupling type		Crowned splines	
Reverse system		Yes	
O.P.A.S. system		Yes	
Steering nozzle pivoting angle		20°	
Minimum required water level		90 cm (35 in) underneath the lowest rear portion of hull	
Drive shaft deflection (maximum)		0.5 mm (.020 in)	
Impeller outside diameter		155.5 ± 0.06 mm (6.122 ± .0024 in)	
Impeller/wear ring clearance	New	GTI: see GTI SE GTI Rental: 0.51 mm (.020 in) minimum	0 - 0.23 mm (0 - .009 in)
	Wear limit	GTI: see GTI SE GTI Rental: 0.76 mm (.030 in)	0.35 mm (.0138 in)
Impeller shaft end play (new)		0	
Impeller shaft side play		0	
Impeller pitch		10° — 21°	
<b>DIMENSIONS</b>			
Number of passenger (driver incl.)		3	
Overall length		322.5 cm (127 in)	
Overall width		124.5 cm (49 in)	
Overall height		113 cm (44 in)	
Dry weight		GTI — 333 kg (734 lb) GTI Rental — 340 kg (750 lb)	340 kg (750 lb)
Load limit (passenger and 10 kg (22 lb) luggage)		272 kg (600 lb)	
<b>CAPACITIES</b>			
Engine oil		3 L (2.7 U.S. qt) oil change w/filter 4.5 L (4.1 U.S. qt) total	
Engine cooling system		5.5 L (4.8 U.S. qt) total	
Fuel tank (including reserve)		60 L (15.9 U.S. gal)	
Fuel tank reserve (from low level signal)		15 L (4 U.S. gal)	



## Section 10 TECHNICAL SPECIFICATIONS

### Subsection 01 (GTI AND GTI SE)

MODEL		GTI	GTI SE
<b>MATERIALS</b>			
Hull		Composite fiberglass	
Inlet grate		Nylon	
Steering cover		Thermoplastic	
Impeller material		Stainless steel	
Impeller housing/stator		Plastic/plastic	
Venturi		GTI — Plastic GTI Rental — Aluminum	Plastic
Nozzle		GTI — Plastic GTI Rental — Aluminum	Plastic
Fuel tank		Polyethylene	
Seat		Polyurethane foam	
<b>PERFORMANCE</b>			
Estimated pump power		46.3 kW (62 HP)	
Maximum fuel consumption at wide open throttle		40.8 L/h (10.8 U.S. gal/h)	
Cruising time at full throttle	Fuel tank without reserve	± 70 minutes	
	Fuel tank reserve (from low level signal)	± 20 minutes	

**Section 10 TECHNICAL SPECIFICATIONS**  
Subsection 02 (GTX AND GTX WAKE)

## GTX AND GTX WAKE

MODEL		GTX	GTX WAKE
<b>ENGINE</b>			
Engine type		ROTAX 1503 4-TEC, 4-stroke, Single Over Head Camshaft (SOHC)	
Induction		Naturally aspirated	
Number of cylinders		3	
Number of valves		12 valves with hydraulic lifters (no adjustment)	
Bore	Standard	100 mm (3.9 in)	
	1 <sup>st</sup> Oversize	100.25 mm (3.95 in)	
Stroke		63.4 mm (2.49 in)	
Displacement		1493.8 mm <sup>3</sup> (58.81 in <sup>3</sup> )	
Compression ratio		10.6:1	
Maximum HP RPM		7300 ± 50 RPM	
Lubrication	Type	Dry sump (2 oil pumps). Replaceable oil filter, Water-cooled oil cooler	
	Oil type	10W40 4-stroke oil (API service classification SL, SJ or SH)	
Intake valve opening		0° BTDC	
Intake valve closing		50° ABDC	
Exhaust valve opening		50° BBDC	
Exhaust valve closing		0° ATDC	
Valve stem diameter	Intake	New	5.961 to 5.975 mm (.2347 to .2352 in)
		Wear limit	5.930 mm (.2330 in)
	Exhaust	New	5.946 to 5.960 mm (.2341 to .2346 in)
		Wear limit	5.930 mm (.2330 in)
Valve guide diameter		New	5.99 to 6.01 mm (.2358 to .2366 in)
		Wear limit	6.060 mm (.2386 in)
Valve spring free length	Inner	New	41.02 mm (1.615 in)
		Wear limit	38.8 mm (1.499 in)
	Outer	New	45.45 mm (1.789 in)
		Wear limit	43 mm (1.693 in)
Valve seat contact width	Intake	New	1.1 to 1.3 mm (.043 to .051 in)
		Wear limit	1.6 mm (.063 in)
	Exhaust	New	1.25 to 1.55 mm (.049 to .061 in)
		Wear limit	1.8 mm (.071 in)
Rocker arm bore diameter		New	20.00 to 20.02 mm (.7874 to .7882 in)
		Wear limit	20.03 mm (.7886 in)
Rocker arm shaft diameter		New	19.98 to 19.99 mm (.7866 to .7870 in)
		Wear limit	19.96 mm (.7858 in)

## Section 10 TECHNICAL SPECIFICATIONS

### Subsection 02 (GTX AND GTX WAKE)

MODEL			GTX	GTX WAKE
<b>ENGINE (con'd)</b>				
Cylinder head screw		Service limit	148.5 mm (5.846 in)	
Cylinder head maximum warpage		Service limit	0.15 mm (.006 in)	
Piston ring type and quantity		1 <sup>st</sup>	Upper compression ring, rectangular	
		2 <sup>nd</sup>	Lower compression ring, tapered face	
		3 <sup>rd</sup>	Oil scraper ring	
Ring end gap	Rectangular	New	0.3 to 0.5 mm (.012 to .020 in)	
	Taper-face		0.3 to 0.5 mm (.012 to .020 in)	
	Oil scraper ring		0.3 to 0.5 mm (.012 to .020 in)	
	All	Wear limit	1 mm (.039 in)	
Ring/piston groove clearance	Rectangular	New	0.02 to 0.07 mm (.0008 to .0028 in)	
	Taper-face		0.015 to 0.06 mm (.0006 to .0024 in)	
	Oil scraper ring		0.02 to 0.055 mm (.0008 to .0021 in)	
	All	Wear limit	0.15 mm (.006 in)	
Piston/cylinder wall clearance		New	0.024 - 0.056 mm (.001 - .0022 in)	
		Wear limit	0.1 mm (.0039 in)	
Cylinder taper		Wear limit	0.1 mm (.0039 in)	
Cylinder out of round		Service limit	0.015 mm (.0006 in)	
Camshaft bearing journal	Front	New	24.93 to 24.96 mm (.9815 to .9827 in)	
		Wear limit	24.93 mm (.9815 in)	
	PTO and center	New	39.89 to 39.9 mm (1.5705 to 1.5709 in)	
		Wear limit	39.88 mm (1.5701 in)	
Camshaft bore	Front	New	25.00 to 25.01 mm (.9842 to .9846 in)	
		Wear limit	25.02 mm (.9850 in)	
	PTO and center	New	40.00 to 40.01 mm (1.5748 to 1.5752 in)	
		Wear limit	40.02 mm (1.5756 in)	
Cam lobe	Intake	New	31.54 to 31.74 mm (1.2417 to 1.2496 in)	
		Wear limit	31.49 mm (1.2397 in)	
	Exhaust	New	31.43 to 31.63 mm (1.2373 to 1.2452 in)	
		Wear limit	31.38 mm (1.2354 in)	
Crankshaft deflection		Maximum	0.050 mm (.002 in)	
Crankshaft axial clearance		New	0.08 to 0.22 mm (.0031 to .0087 in)	
		Wear limit	0.35 mm (.014 in)	
Crankshaft journal diameter		New	49.991 to 50.000 mm (1.9681 to 1.9685 in)	
		Wear limit	49.950 mm (1.9665 in)	
Crankshaft radial clearance		Wear limit	0.007 mm (.0028 in)	
Connecting rod big end diameter		Service limit	45.080 mm (1.7740 in)	
Connecting rod big end clearance		Service limit	0.09 mm (.0039 in)	
Connecting rod big end axial play		New	0.135 to 0.287 mm (.0053 to .0113 in)	
		Wear limit	0.500 mm (.0197 in)	
Connecting rod small end diameter		New	23.010 to 23.020 mm (.9059 to .9063 in)	
		Wear limit	23.070 mm (.9080 in)	



## Section 10 TECHNICAL SPECIFICATIONS

### Subsection 02 (GTX AND GTX WAKE)

MODEL		GTX	GTX WAKE
<b>ENGINE (con'd)</b>			
Piston pin diameter	New	22.99 to 23.000 mm (.9051 to .9055 in)	
	Wear limit	22.980 mm (.9047 in)	
Piston pin bore clearance	Wear limit	0.080 mm (.0035 in)	
Balance shaft journal diameter	New	31.98 to 32.000 mm (1.2591 to 1.2598 in)	
	Wear limit	31.950 mm (1.2579 in)	
Balance shaft radial clearance	Wear limit	0.07 mm (.0028 in)	
Balance shaft axial clearance	New	0.02 to 0.25 mm (.0008 to .0098 in)	
<b>ENGINE COOLING SYSTEM</b>			
Type		Closed loop cooling system	
Coolant		Ethylene-glycol and distilled water (50%/50%). Use premix coolant from BRP or a coolant specially formulated for aluminum engines	
Thermostat		87°C (188°F)	
Monitoring beeper setting		100°C (212°F)	
<b>EXHAUST SYSTEM</b>			
Type		Water cooled/water injected (opened loop). Direct flow from jet pump	
<b>ELECTRICAL SYSTEM</b>			
Magneto generator output		380 W @ 6000 RPM	
Ignition system type		DI (Digital Induction)	
Ignition timing		Not adjustable	
Spark plug	Make and type	NGK DCPR8E	
	Gap	0.7 - 0.8 mm (.028 to .031 in)	
Generating coil		N.A.	
Battery charging coil		0.1 - 1.0 Ω	
Ignition coil	Primary	0.85 - 1.15 Ω	
	Secondary	9.5 - 13.5 kΩ	
Engine RPM limiter setting		7650 RPM	
Battery		12 V, 30 A•h	
Fuse	Accessories	2 A — 5 A	
	Battery	30 A	
	Cylinder 1, ignition coil and injection	10 A	
	Cylinder 2, ignition coil and injection	10 A	
	Cylinder 3, ignition coil and injection	10 A	
	Electric bilge pump (optional)	3 A	
	Starting system, electric fuel pump	10 A	
	EMS, start/stop circuit	5 A	
	Main	30 A	
	MPEM	2 A	
	Charging system	30 A	
	Information center	1 A	
	VTS	7.5 A (installed but not in use)	

## Section 10 TECHNICAL SPECIFICATIONS

### Subsection 02 (GTX AND GTX WAKE)

MODEL		GTX	GTX WAKE
<b>FUEL SYSTEM</b>			
Fuel injection type		Rotax EMS (engine management system) Multipoint Fuel Injection. Single throttle body (52 mm)	
Fuel pressure		290 - 310 kPa (42 - 45 PSI)	
Fuel type	Inside North America	Unleaded gasoline with a minimum of 87 octane (RON + MON)/2	
	Outside North America	Unleaded gasoline with a minimum of 91 octane RON	
Idle speed		1800 ± 50 RPM (NOT ADJUSTABLE)	
<b>PROPULSION SYSTEM</b>			
Jet pump type		Axial flow single stage	
Jet pump grease		Bearing grease (P/N 293 550 032)	
Impeller rotation (seen from rear)		Counterclockwise	
Transmission		Direct drive	
Coupling type		Crowned splines	
Reverse system		Yes	
O.P.A.S. system		Yes	
Steering nozzle pivoting angle		20°	
Minimum required water level		90 cm (35 in) underneath the lowest rear portion of hull	
Drive shaft deflection (maximum)		0.5 mm (.020 in)	
Impeller outside diameter		155.5 ± 0.06 mm (6.122 ± .0024 in)	
Impeller/wear ring clearance	New	0 - 0.23 mm (0 - .009 in)	
	Wear limit	0.35 mm (.0138 in)	
Impeller shaft end play (new)		0	
Impeller shaft side play		0	
Impeller pitch		10° — 21°	
<b>DIMENSIONS</b>			
Number of passenger (driver incl.)		3	
Overall length		331 cm (130 in)	
Overall width		122 cm (48 in)	
Overall height		113 cm (44 in)	
Dry weight		384 kg (847 lb)	393 kg (867 lb)
Load limit (passenger and 10 kg (22 lb) luggage)		272 kg (600 lb)	
<b>CAPACITIES</b>			
Engine oil		3 L (2.7 U.S. qt) oil change w/filter 4.5 L (4.1 U.S. qt) total	
Engine cooling system		5.5 L (4.8 U.S. qt) total	
Fuel tank (including reserve)		60 L (15.9 U.S. gal)	
Fuel tank reserve (from low level signal)		15 L (4 U.S. gal)	

## Section 10 TECHNICAL SPECIFICATIONS

### Subsection 02 (GTX AND GTX WAKE)

MODEL	GTX	GTX WAKE
<b>MATERIALS</b>		
Hull	Composite fiberglass	
Inlet grate	Aluminum	
Steering cover	Thermoplastic	
Impeller material	Stainless steel	
Impeller housing/stator	Plastic/plastic	
Venturi	Aluminum	
Nozzle	Aluminum	
Fuel tank	Polyethylene	
Seat	Polyurethane foam	
<b>PERFORMANCE</b>		
Estimated pump power	52.6 kW (71 HP)	
Maximum fuel consumption at wide open throttle	43.1 L/h (11.4 U.S. gal/h)	
Cruising time at full throttle	Fuel tank without reserve	± 60 minutes
	Fuel tank reserve (from low level signal)	± 20 minutes



**Section 10 TECHNICAL SPECIFICATIONS**  
Subsection 03 (GTX SUPERCHARGED AND GTX LIMITED)

# GTX SUPERCHARGED AND GTX LIMITED

MODEL		GTX SUPERCHARGED	GTX LIMITED
<b>ENGINE</b>			
Engine type		ROTAX 1503 4-TEC, 4-stroke, Single Over Head Camshaft (SOHC)	
Induction		Supercharged	Supercharged intercooled
Number of cylinders		3	
Number of valves		12 valves with hydraulic lifters (no adjustment)	
Bore	Standard	100 mm (3.9 in)	
	1 <sup>st</sup> Oversize	100.25 mm (3.95 in)	
Stroke		63.4 mm (2.49 in)	
Displacement		1493.8 mm <sup>3</sup> (58.81 in <sup>3</sup> )	
Compression ratio		8.1:1	8.4:1
Maximum HP RPM		7500 ± 50 RPM	8000 ± 50 RPM
Lubrication	Type	Dry sump (2 oil pumps). Replaceable oil filter. Water-cooled oil cooler	
	Oil type	XP-S 10W40 4-stroke oil or an equivalent approved by BRP	
Intake valve opening		10° BTDC	0° BTDC
Intake valve closing		45° ABDC	50 ABDC
Exhaust valve opening		50° BBDC	50° BBDC
Exhaust valve closing		0° ATDC	0° ATDC
Valve stem diameter	Intake	New	5.961 to 5.975 mm (.2347 to .2352 in)
		Wear limit	5.930 mm (.2330 in)
	Exhaust	New	5.946 to 5.960 mm (.2341 to .2346 in)
		Wear limit	5.930 mm (.2330 in)
Valve guide diameter	New	5.99 to 6.01 mm (.2358 to .2366 in)	
	Wear limit	6.060 mm (.2386 in)	
Valve spring free length	Inner	New	41.02 mm (1.615 in)
		Wear limit	38.8 mm (1.499 in)
	Outer	New	45.45 mm (1.789 in)
		Wear limit	43 mm (1.693 in)
Valve seat contact width	Intake	New	1.1 to 1.3 mm (.043 to .051 in)
		Wear limit	1.6 mm (.063 in)
	Exhaust	New	1.25 to 1.55 mm (.049 to .061 in)
		Wear limit	1.8 mm (.071 in)
Rocker arm bore diameter	New	20.00 to 20.02 mm (.7874 to .7882 in)	
	Wear limit	20.03 mm (.7886 in)	
Rocker arm shaft diameter	New	19.98 to 19.99 mm (.7866 to .7870 in)	
	Wear limit	19.96 mm (.7858 in)	

## Section 10 TECHNICAL SPECIFICATIONS

### Subsection 03 (GTX SUPERCHARGED AND GTX LIMITED)

MODEL		GTX SUPERCHARGED	GTX LIMITED
<b>ENGINE (con'd)</b>			
Cylinder head screw		Service limit	148.5 mm (5.846 in)
Cylinder head maximum warpage		Service limit	0.15 mm (.006 in)
Piston ring type and quantity		1 <sup>st</sup>	Upper compression ring, rectangular
		2 <sup>nd</sup>	Lower compression ring, tapered face
		3 <sup>rd</sup>	Oil scraper ring
Ring end gap	Rectangular	New	0.3 to 0.5 mm (.012 to .020 in)
	Taper-face		0.3 to 0.5 mm (.012 to .020 in)
	Oil scraper ring		0.3 to 0.5 mm (.012 to .020 in)
	All	Wear limit	1 mm (.039 in)
Ring/piston groove clearance	Rectangular	New	0.02 to 0.07 mm (.0008 to .0028 in)
	Taper-face		0.02 to 0.06 mm (.0008 to .0024 in)
	Oil scraper ring		0.02 to 0.055 mm (.0008 to .0021 in)
	All	Wear limit	0.15 mm (.006 in)
Piston/cylinder wall clearance		New	0.04 mm (.0016 in)      0.06 mm (.0023 in)
		Wear limit	0.1 mm (.0039 in)
Cylinder taper		Wear limit	0.1 mm (.0039 in)
Cylinder out of round		Service limit	0.015 mm (.0006 in)
Camshaft bearing journal	Front	New	24.93 to 24.96 mm (.9815 to .9827 in)
		Wear limit	24.93 mm (.9815 in)
	PTO and center	New	39.89 to 39.9 mm (1.5705 to 1.5709 in)
		Wear limit	39.88 mm (1.5701 in)
Camshaft bore	Front	New	25.00 to 25.01 mm (.9842 to .9846 in)
		Wear limit	25.02 mm (.9850 in)
	PTO and center	New	40.00 to 40.01 mm (1.5748 to 1.5752 in)
		Wear limit	40.02 mm (1.5756 in)
Cam lobe	Intake	New	31.65 to 31.85 mm (1.2460 to 1.2539 in)      31.54 to 31.74 mm (1.2417 to 1.2496 in)
		Wear limit	31.60 mm (1.2440 in)      31.49 mm (1.2397 in)
	Exhaust	New	31.43 to 31.63 mm (1.2373 to 1.2452 in)
		Wear limit	31.38 mm (1.2354 in)
Crankshaft deflection		Maximum	0.050 mm (.002 in)
Crankshaft axial clearance		New	0.08 to 0.22 mm (.0031 to .0087 in)
		Wear limit	0.35 mm (.014 in)
Crankshaft journal diameter		New	49.991 to 50.000 mm (1.9681 to 1.9685 in)
		Wear limit	49.950 mm (1.9665 in)
Crankshaft radial clearance		Wear limit	0.007 mm (.0028 in)
Connecting rod big end diameter		Service limit	45.080 mm (1.7740 in)
Connecting rod big end clearance		Service limit	0.09 mm (.0039 in)
Connecting rod big end axial play		New	0.135 to 0.287 mm (.0053 to .0113 in)
		Wear limit	0.500 mm (.0197 in)
Connecting rod small end diameter		New	23.010 to 23.020 mm (.9059 to .9063 in)
		Wear limit	23.070 mm (.9080 in)

## Section 10 TECHNICAL SPECIFICATIONS

### Subsection 03 (GTX SUPERCHARGED AND GTX LIMITED)

MODEL		GTX SUPERCHARGED	GTX LIMITED
<b>ENGINE (con'd)</b>			
Piston pin diameter	New	22.99 to 23.000 mm (.9051 to .9055 in)	
	Wear limit	22.980 mm (.9047 in)	
Piston pin bore clearance	Wear limit	0.080 mm (.0035 in)	
Balance shaft journal diameter	New	31.98 to 32.000 mm (1.2591 to 1.2598 in)	
	Wear limit	31.950 mm (1.2579 in)	
Balance shaft radial clearance	Wear limit	0.07 mm (.0028 in)	
Balance shaft axial clearance	New	0.02 to 0.25 mm (.0008 to .0098 in)	
Supercharger shaft driven plate journal depth	New	12.46 to 12.50 mm (.490 to .492 in)	
	Wear limit	12.80 mm (.503 in)	
Supercharger drive gear thickness	New	11.00 to 11.05 mm (.433 to .435 in)	
	Wear limit	10.50 mm (.413 in)	
Supercharger lock washer thickness	New	4.05 to 4.15 mm (.159 to .163 in)	
	Wear limit	3.75 mm (.147 in)	
<b>ENGINE COOLING SYSTEM</b>			
Type	Closed loop cooling system		
Coolant	Ethylene-glycol and distilled water (50%/50%). Use premix coolant from BRP or a coolant specially formulated for aluminum engines		
Thermostat	87°C (188°F)		
Monitoring beeper setting	100°C (212°F)		
<b>EXHAUST SYSTEM</b>			
Type	Water cooled/water injected (opened loop). Direct flow from jet pump		
<b>ELECTRICAL SYSTEM</b>			
Magneto generator output	380 W @ 6000 RPM		
Ignition system type	DI (Digital Induction)		
Ignition timing	Not adjustable		
Spark plug	Make and type	NGK DCPR8E	
	Gap	0.7 - 0.8 mm (.028 to .031 in)	
Generating coil	N.A.		
Battery charging coil	0.1 - 1.0 Ω		
Ignition coil	Primary	0.85 - 1.15 Ω	
	Secondary	9.5 - 13.5 kΩ	
Engine RPM limiter setting	7650 RPM	8200 RPM	
Battery	12 V, 30 A•h		



## Section 10 TECHNICAL SPECIFICATIONS

### Subsection 03 (GTX SUPERCHARGED AND GTX LIMITED)

MODEL		GTX SUPERCHARGED	GTX LIMITED
<b>ELECTRICAL SYSTEM (con'd)</b>			
Fuse	Accessories	2 A — 5 A	
	Battery	30 A	
	Cylinder 1, ignition coil and injection	10 A	
	Cylinder 2, ignition coil and injection	10 A	
	Cylinder 3, ignition coil and injection	10 A	
	Electric bilge pump (optional)	3 A	
	Starting system, electric fuel pump	10 A	
	EMS, start/stop circuit	5 A	
	Main	30 A	
	MPEM	2 A	
	Charging system	30 A	
	Information center	1 A	
	VTS	7.5 A (installed but not in use)	
<b>FUEL SYSTEM</b>			
Fuel injection type		Rotax EMS (engine management system) Multipoint Fuel Injection. Single throttle body (52 mm)	
Fuel pressure		290 - 310 kPa (42 - 45 PSI)	386 - 414 kPa (56 - 60 PSI)
Fuel type	Inside North America	Premium unleaded gasoline with a minimum of 91 octane (RON + MON)/2	
	Outside North America	Premium unleaded gasoline with a minimum of 95 octane RON	
Idle speed		1800 ± 50 RPM (NOT ADJUSTABLE)	
<b>PROPULSION SYSTEM</b>			
Jet pump type		Axial flow single stage	
Jet pump grease type		Bearing grease (P/N 293 550 032)	
Impeller rotation (seen from rear)		Counterclockwise	
Transmission		Direct drive	
Coupling type		Crowned splines	
Reverse system		Yes	
O.P.A.S. system		Yes	
Steering nozzle pivoting angle		20°	
Minimum required water level		90 cm (35 in) underneath the lowest rear portion of hull	
Drive shaft deflection (maximum)		0.5 mm (.020 in)	
Impeller outside diameter		155.5 ± 0.06 mm (6.122 ± .0024 in)	159 ± 0.06 mm (6.260 ± .0024 in)
Impeller/wear ring clearance	New	0 - 0.23 mm (0 - .009 in)	
	Wear limit	0.35 mm (.0138 in)	
Impeller shaft end play (new)		0	
Impeller shaft side play		0	
Impeller pitch		10° — 21°	

**Section 10 TECHNICAL SPECIFICATIONS**  
Subsection 03 (GTX SUPERCHARGED AND GTX LIMITED)

MODEL		GTX SUPERCHARGED	GTX LIMITED
<b>DIMENSIONS</b>			
Number of passenger (driver incl.)		3	
Overall length		331 cm (130 in)	
Overall width		122 cm (48 in)	
Overall height		113 cm (44 in)	
Dry weight		389 kg (857 lb)	397 kg (875 lb)
Load limit (passenger and 10 kg (22 lb) luggage)		272 kg (600 lb)	
<b>CAPACITIES</b>			
Engine oil		3 L (2.7 U.S. qt) oil change w/filter 4.5 L (4.1 U.S. qt) total	
Cooling system (coolant)		5.5 L (4.8 U.S. qt) total	
Fuel tank (including reserve)		60 L (15.9 U.S. gal)	
Fuel tank reserve (from low level signal)		15 L (4 U.S. gal)	
<b>MATERIALS</b>			
Hull		Composite fiberglass	
Inlet grate		Aluminum	
Steering cover		Thermoplastic	
Impeller material		Stainless steel	
Impeller housing/stator		Aluminum/Aluminum	
Venturi		Aluminum	
Nozzle		Aluminum	
Fuel tank		Polyethylene	
Seat		Polyurethane foam	
<b>PERFORMANCE</b>			
Estimated pump power		61.7 kW (82.7 HP)	85.1 kW (114 HP)
Maximum fuel consumption at wide open throttle		59 L/h (15.6 U.S. gal/h)	69 L/h (18.2 U.S. gal/h)
Cruising time at full throttle	Fuel tank without reserve	± 45 minutes	± 40 minutes
	Fuel tank reserve (from low level signal)	± 15 minutes	± 13 minutes

## Section 10 TECHNICAL SPECIFICATIONS

### Subsection 04 (RXP AND RXT MODELS)

# RXP AND RXT MODELS

MODEL			RXP	RXT
<b>ENGINE</b>				
Engine type			ROTAX 1503 4-TEC, 4-stroke, Single Over Head Camshaft (SOHC)	
Induction			Supercharged intercooled	
Number of cylinders			3	
Number of valves			12 valves with hydraulic lifters (no adjustment)	
Bore	Standard		100 mm (3.9 in)	
	1 <sup>st</sup> Oversize		100.25 mm (3.95 in)	
Stroke			63.4 mm (2.49 in)	
Displacement			1493.8 mm <sup>3</sup> (58.81 in <sup>3</sup> )	
Compression ratio			8.4:1	
Maximum HP RPM			8000 ± 50 RPM	
Lubrication	Type		Dry sump (2 oil pumps). Replaceable oil filter. Water-cooled oil cooler	
	Oil type		XP-S 10W40 4-stroke oil or an equivalent approved by BRP	
Intake valve opening			0° BTDC	
Intake valve closing			50 ABDC	
Exhaust valve opening			50° BBDC	
Exhaust valve closing			0° ATDC	
Valve stem diameter	Intake	New	5.961 to 5.975 mm (.2347 to .2352 in)	
		Wear limit	5.930 mm (.2330 in)	
	Exhaust	New	5.946 to 5.960 mm (.2341 to .2346 in)	
		Wear limit	5.930 mm (.2330 in)	
Valve guide diameter		New	5.99 to 6.01 mm (.2358 to .2366 in)	
		Wear limit	6.060 mm (.2386 in)	
Valve spring free length	Inner	New	41.02 mm (1.615 in)	
		Wear limit	38.8 mm (1.499 in)	
	Outer	New	45.45 mm (1.789 in)	
		Wear limit	43 mm (1.693 in)	
Valve seat contact width	Intake	New	1.1 to 1.3 mm (.043 to .051 in)	
		Wear limit	1.6 mm (.063 in)	
	Exhaust	New	1.25 to 1.55 mm (.049 to .061 in)	
		Wear limit	1.8 mm (.071 in)	
Rocker arm bore diameter		New	20.00 to 20.02 mm (.7874 to .7882 in)	
		Wear limit	20.03 mm (.7886 in)	
Rocker arm shaft diameter		New	19.98 to 19.99 mm (.7866 to .7870 in)	
		Wear limit	19.96 mm (.7858 in)	



## Section 10 TECHNICAL SPECIFICATIONS

### Subsection 04 (RXP AND RXT MODELS)

MODEL		RXP	RXT
<b>ENGINE (con'd)</b>			
Cylinder head screw		Service limit	148.5 mm (5.846 in)
Cylinder head maximum warpage		Service limit	0.15 mm (.006 in)
Piston ring type and quantity		1 <sup>st</sup>	Upper compression ring, rectangular
		2 <sup>nd</sup>	Lower compression ring, tapered face
		3 <sup>rd</sup>	Oil scraper ring
Ring end gap	Rectangular	New	0.3 to 0.5 mm (.012 to .020 in)
	Taper face		0.3 to 0.5 mm (.012 to .020 in)
	Oil scraper ring		0.3 to 0.5 mm (.012 to .020 in)
	All	Wear limit	1 mm (.039 in)
Ring/piston groove clearance	Rectangular	New	0.02 to 0.07 mm (.0008 to .0028 in)
	Taper-face		0.02 to 0.06 mm (.0008 to .0024 in)
	Oil scraper ring		0.02 to 0.055 mm (.0008 to .0021 in)
	All	Wear limit	0.15 mm (.006 in)
Piston/cylinder wall clearance		New	0.06 mm (.0023 in)
		Wear limit	0.1 mm (.0039 in)
Cylinder taper		Wear limit	0.1 mm (.0039 in)
Cylinder out of round		Service limit	0.015 mm (.0006 in)
Camshaft bearing journal	Front	New	24.93 to 24.96 mm (.9815 to .9827 in)
		Wear limit	24.93 mm (.9815 in)
	PTO and center	New	39.89 to 39.9 mm (1.5705 to 1.5709 in)
		Wear limit	39.88 mm (1.5701 in)
Camshaft bore	Front	New	25.00 to 25.01 mm (.9842 to .9846 in)
		Wear limit	25.02 mm (.9850 in)
	PTO and center	New	40.00 to 40.01 mm (1.5748 to 1.5752 in)
		Wear limit	40.02 mm (1.5756 in)
Cam lobe	Intake	New	31.54 to 31.74 mm (1.2417 to 1.2496 in)
		Wear limit	31.49 mm (1.2397 in)
	Exhaust	New	31.43 to 31.63 mm (1.2373 to 1.2452 in)
		Wear limit	31.38 mm (1.2354 in)
Crankshaft deflection		Maximum	0.050 mm (.002 in)
Crankshaft axial clearance		New	0.08 to 0.22 mm (.0031 to .0087 in)
		Wear limit	0.35 mm (.014 in)
Crankshaft journal diameter		New	49.991 to 50.000 mm (1.9681 to 1.9685 in)
		Wear limit	49.950 mm (1.9665 in)
Crankshaft radial clearance		Wear limit	0.007 mm (.0028 in)
Connecting rod big end diameter		Service limit	45.080 mm (1.7740 in)
Connecting rod big end clearance		Service limit	0.09 mm (.0039 in)
Connecting rod big end axial play		New	0.135 to 0.287 mm (.0053 to .0113 in)
		Wear limit	0.500 mm (.0197 in)
Connecting rod small end diameter		New	23.010 to 23.020 mm (.9059 to .9063 in)
		Wear limit	23.070 mm (.9080 in)

## Section 10 TECHNICAL SPECIFICATIONS

### Subsection 04 (RXP AND RXT MODELS)

MODEL		RXP	RXT
<b>ENGINE (con'd)</b>			
Piston pin diameter	New	22.99 to 23.000 mm (.9051 to .9055 in)	
	Wear limit	22.980 mm (.9047 in)	
Piston pin bore clearance	Wear limit	0.080 mm (.0035 in)	
Balance shaft journal diameter	New	31.98 to 32.000 mm (1.2591 to 1.2598 in)	
	Wear limit	31.950 mm (1.2579 in)	
Balance shaft radial clearance	Wear limit	0.07 mm (.0028 in)	
Balance shaft axial clearance	New	0.02 to 0.25 mm (.0008 to .0098 in)	
Supercharger shaft driven plate journal depth	New	12.46 to 12.50 mm (.490 to .492 in)	
	Wear limit	12.80 mm (.503 in)	
Supercharger drive gear thickness	New	11.00 to 11.05 mm (.433 to .435 in)	
	Wear limit	10.50 mm (.413 in)	
Supercharger lock washer thickness	New	4.05 to 4.15 mm (.159 to .163 in)	
	Wear limit	3.75 mm (.147 in)	
<b>ENGINE COOLING SYSTEM</b>			
Type	Closed loop cooling system		
Coolant	Ethylene-glycol and distilled water (50%/50%). Use premix coolant from BRP or a coolant specially formulated for aluminum engines		
Thermostat	87°C (188°F)		
Monitoring beeper setting	100°C (212°F)		
<b>EXHAUST SYSTEM</b>			
Type	Water cooled/water injected (opened loop). Direct flow from jet pump		
<b>ELECTRICAL SYSTEM</b>			
Magneto generator output	380 W @ 6000 RPM		
Ignition system type	DI (Digital Induction)		
Ignition timing	Not adjustable		
Spark plug	Make and type	NGK DCPR8E	
	Gap	0.7 - 0.8 mm (.028 to .031 in)	
Generating coil	N.A.		
Battery charging coil	0.1 - 1.0 Ω		
Ignition coil	Primary	0.85 - 1.15 Ω	
	Secondary	9.5 - 13.5 kΩ	
Engine RPM limiter setting	8200 RPM		
Battery	12 V, 30 A•h		

## Section 10 TECHNICAL SPECIFICATIONS

### Subsection 04 (RXP AND RXT MODELS)

MODEL		RXP	RXT
<b>ELECTRICAL SYSTEM (con'd)</b>			
Fuse	Accessories	2 A — 5 A	
	Battery fuse	30 A	
	Cylinder 1, ignition coil and injection	10 A	
	Cylinder 2, ignition coil and injection	10 A	
	Cylinder 3, ignition coil and injection	10 A	
	Electric bilge pump (optional)	3 A	
	Starting system, electric fuel pump	10 A	
	EMS, start/stop circuit	5 A	
	Main	30 A	
	MPEM	2 A	
	Charging system	30 A	
	Information center	1 A	
	VTS	7.5 A	7.5 A (installed but not in use)
<b>FUEL SYSTEM</b>			
Fuel injection type		Rotax EMS (engine management system) Multipoint Fuel Injection, Single throttle body (52 mm)	
Fuel pressure		386 - 414 kPa (56 - 60 PSI)	
Fuel type	Inside North America	Premium unleaded gasoline with a minimum of 91 octane (RON + MON)/2	
	Outside North America	Premium unleaded gasoline with a minimum of 95 octane RON	
Idle speed		1800 ± 50 RPM (NOT ADJUSTABLE)	
<b>PROPULSION SYSTEM</b>			
Jet pump type		Axial flow single stage	
Jet pump grease type		Bearing grease (P/N 293 550 032)	
Impeller rotation (seen from rear)		Counterclockwise	
Transmission		Direct drive	
Coupling type		Crowned splines	
Reverse system		Yes	
O.P.A.S. system		Yes	
Steering nozzle pivoting angle		20°	
Minimum required water level		90 cm (35 in) underneath the lowest rear portion of hull	
Drive shaft deflection (maximum)		0.5 mm (.020 in)	
Impeller outside diameter		159 ± 0.06 mm (6.260 ± .0024 in)	
Impeller/wear ring clearance	New	0 - 0.23 mm (0 - .009 in)	
	Wear limit	0.35 mm (.0138 in)	
Impeller shaft end play (new)		0	
Impeller shaft side play		0	
Impeller pitch		10° — 21°	



**Section 10 TECHNICAL SPECIFICATIONS**  
Subsection 04 (RXP AND RXT MODELS)

MODEL		RXP	RXT
<b>DIMENSIONS</b>			
Number of passenger (driver incl.)		2	3
Overall length		307 cm (121 in)	331 cm (130 in)
Overall width		122 cm (48 in)	
Overall height		109 cm (43 in)	113 cm (44 in)
Dry weight		359 kg (792 lb)	394 kg (869 lb)
Load limit (passenger and 10 kg (22 lb) luggage)		272 kg (600 lb)	
<b>CAPACITIES</b>			
Engine oil		3 L (2.7 U.S. qt) oil change w/filter 4.5 L (4.1 U.S. qt) total	
Engine cooling system		5.5 L (4.8 U.S. qt) total	
Fuel tank (including reserve)		60 L (15.9 U.S. gal)	
Fuel tank reserve (from low level signal)		15 L (4 U.S. gal)	
<b>MATERIALS</b>			
Hull		Composite fiberglass	
Inlet grate		Aluminum	
Steering cover		Thermoplastic	
Impeller material		Stainless steel	
Impeller housing/stator		Aluminum/Aluminum	
Venturi		Aluminum	
Nozzle		Aluminum	
Fuel tank		Polyethylene	
Seat		Polyurethane foam	
<b>PERFORMANCE</b>			
Estimated pump power		77.5 kW (104 HP)	85.1 kW (114 HP)
Maximum fuel consumption at wide open throttle		69 L/h (18.2 U.S. gal/h)	
Cruising time at full throttle	Fuel tank without reserve	± 40 minutes	
	Fuel tank reserve (from low level signal)	± 13 minutes	

# ELECTRICAL CONNECTORS

## SERVICE TOOLS

Description	Part Number	Page
crimper die.....	529 035 906	399
crimper die.....	529 035 908	396
crimping pliers .....	529 035 730	400
crimping tool.....	529 035 909	396, 399

## DEUTSCH CONNECTORS

Deutsch connectors are used on some harnesses.

### Removal from Engine Connector Bracket

To remove Deutsch connectors from engine connector bracket, remove the expansion coolant tank.



1. Expansion coolant tank  
 2. Tank bracket

Slide a flat screwdriver between the connector bracket and the Deutsch connectors and remove connectors.

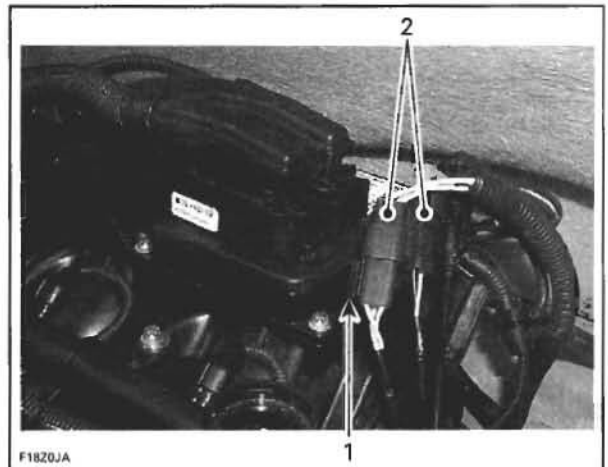

1. Engine connector bracket  
 2. Deutsch connectors

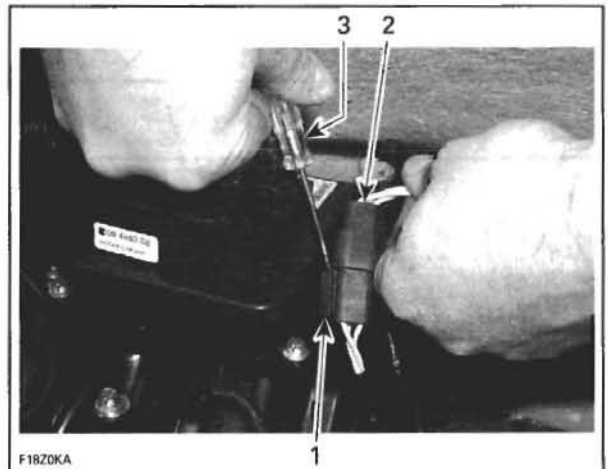

1. Engine connector bracket  
 2. Deutsch connectors  
 3. Flat screwdriver

To disconnect the two Deutsch connectors, slide a flat screwdriver between each other to disengage, press the release button and disconnect them.

# Section 11 ELECTRICAL CONNECTORS AND WIRING DIAGRAM

## Subsection 01 (ELECTRICAL CONNECTORS)

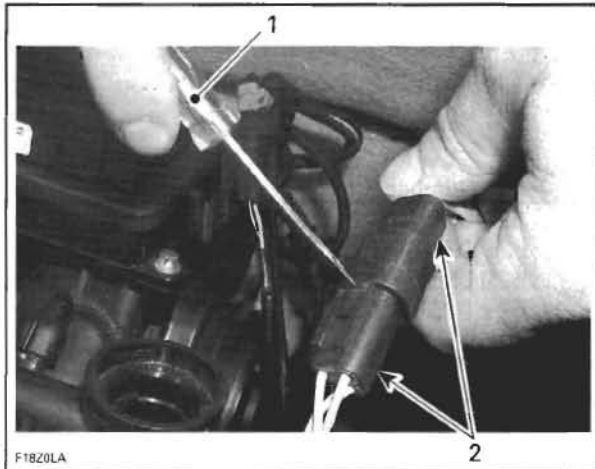

F1820LA

1. Flat screwdriver
2. Deutsch connectors

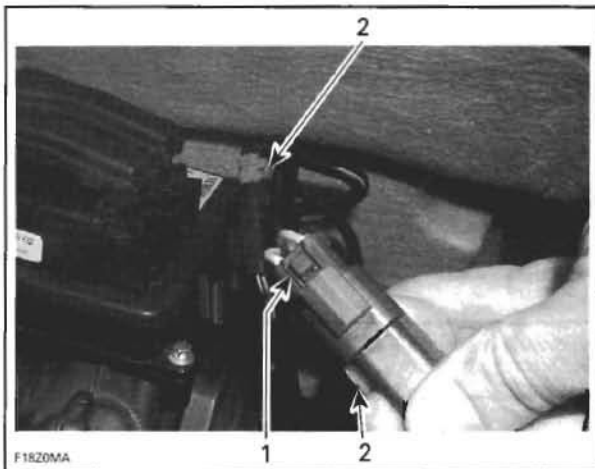

F1820MA

1. Release button
2. Deutsch connectors

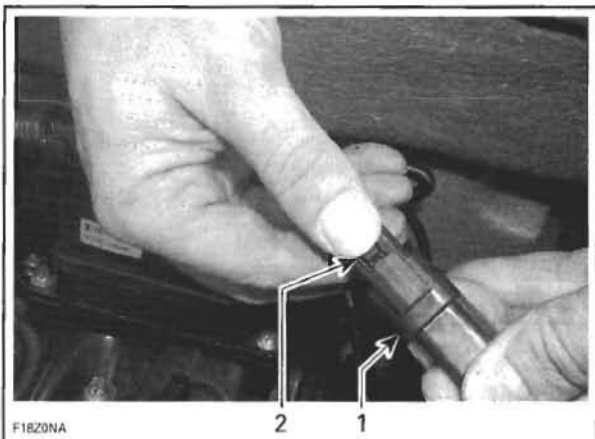

F1820NA

1. Deutsch connectors
2. Press release button

### Connector Disassembly

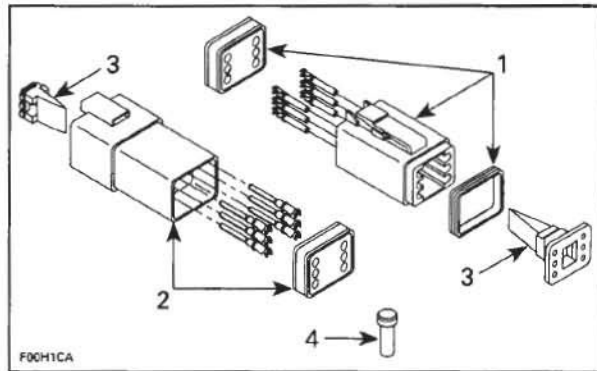

F00H1CA

1. Male connector
2. Female connector
3. Secondary lock
4. Sealing cap

**CAUTION:** Do not apply dielectric grease on terminal inside connector.

To remove terminals from connector, proceed as follows:

- Using a long nose pliers, pull out the lock.

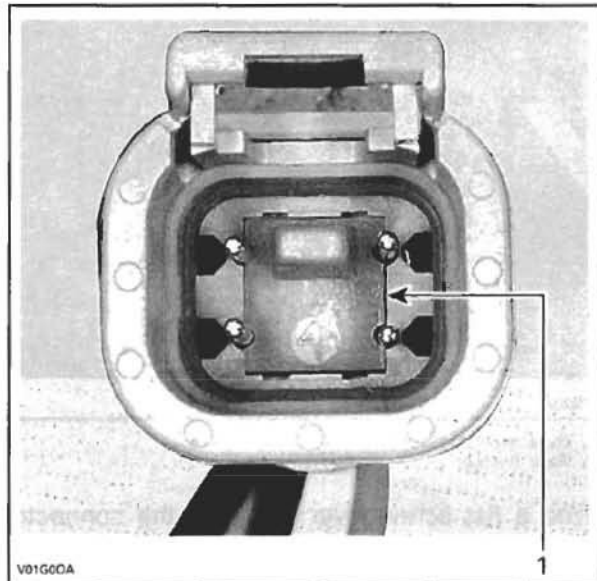

V01G0DA

- FEMALE CONNECTOR**
1. Female lock



## Section 11 ELECTRICAL CONNECTORS AND WIRING DIAGRAM

### Subsection 01 (ELECTRICAL CONNECTORS)

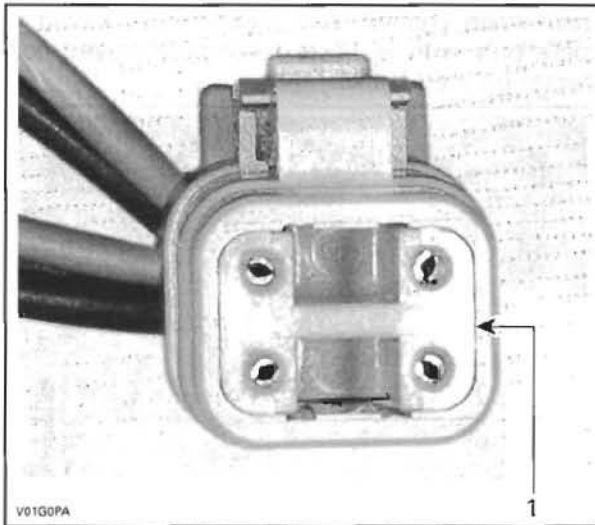

**MALE CONNECTOR**

1. Male lock

**NOTE:** Before extraction, push wire forward to relieve pressure on retaining tab.

- Insert a 4.8 mm (.189 in) wide screwdriver blade inside the front of the terminal cavity.
- Pry back the retaining tab while gently pulling wire back until terminal is removed.

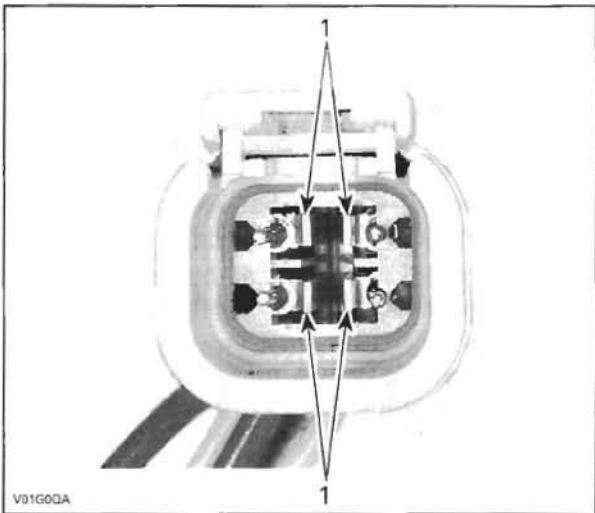

**FEMALE CONNECTOR**

1. Retaining tab

To install:

- For insertion of a terminal, make sure the lock is removed.
- Insert terminal into appropriate cavity and push as far as it will go.
- Pull back on the terminal wire to be sure the retention fingers are holding the terminal.
- After all required terminals have been inserted, the lock must be installed.

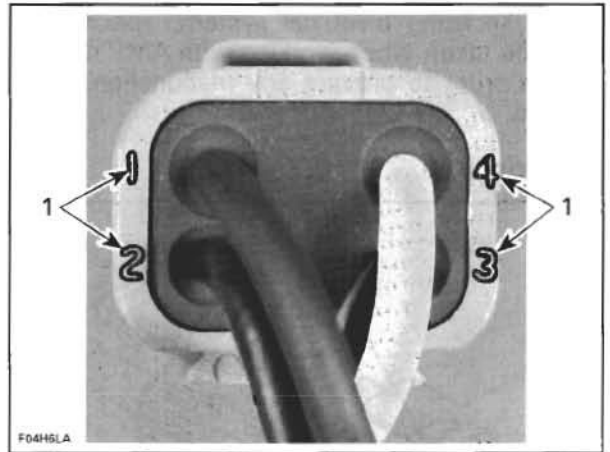

1. Wire identification numbers

## PACKARD CONNECTOR

Packard connectors are used to connect electrical harnesses and gauges.

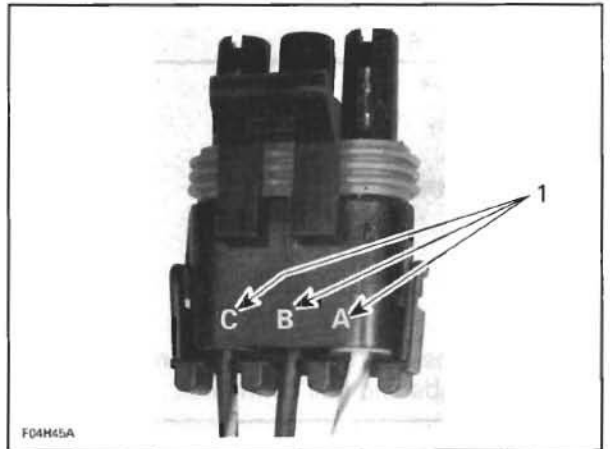

**VIEW OF A 3-PIN PACKARD CONNECTOR**

1. Identification letters

To remove terminal from Packard connector, use Snap-on TT600-4 tool.

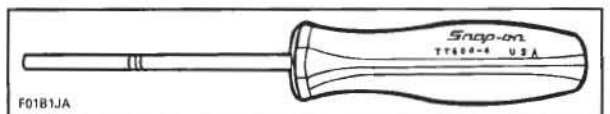

### **WARNING**

Ensure all terminals are properly crimped on wires and connector are properly fastened.

## AMP CONNECTOR

These connectors are found on the MPEM.

## Section 11 ELECTRICAL CONNECTORS AND WIRING DIAGRAM

### Subsection 01 (ELECTRICAL CONNECTORS)

When servicing electrical system, special care must be taken when working with AMP connectors in order to prevent any malfunction of the system.

#### Description

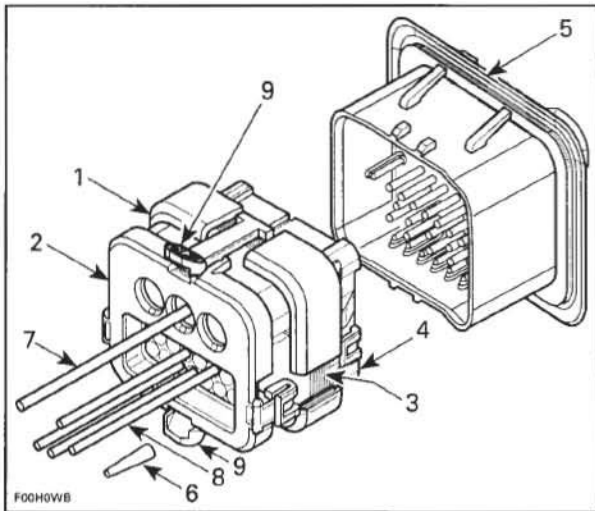

#### AMP CONNECTOR

1. Male connector
2. Cover assembly
3. Mating seal
4. Wedge lock
5. MPEM connector
6. Seal plug
7. Power wire
8. Signal wire
9. Locking tab

#### Removal

To remove the male connector from the MPEM, press both tabs and pull connector.

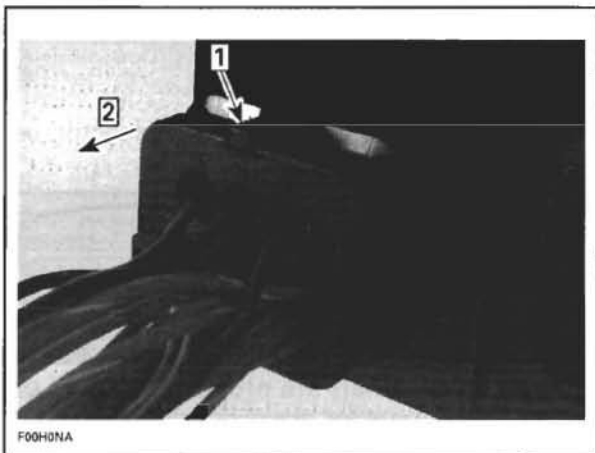

- Step 1: Press tabs (both sides)  
Step 2: Pull male connector

#### Installation

Do not apply any product to the pins of the connectors on the MPEM.

Each male connector is mechanically keyed to mate only with identical mechanical keyed connector on the MPEM.

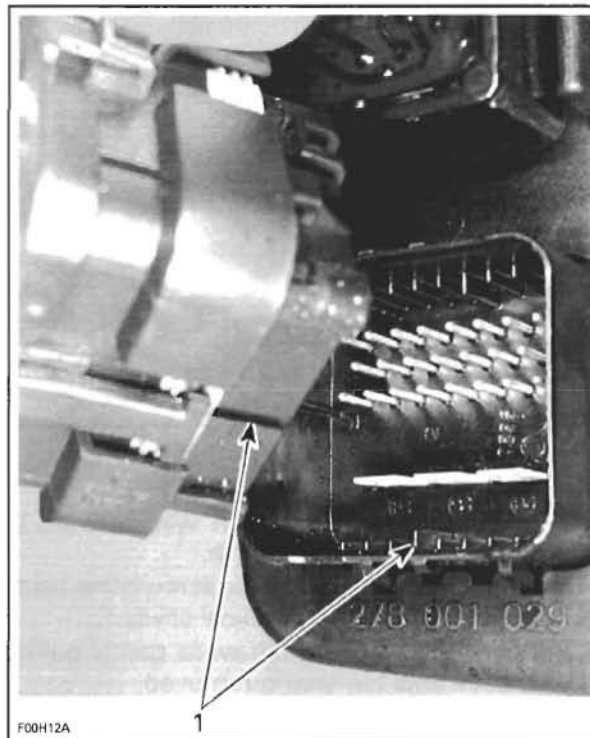

1. Mechanically keyed

#### Terminal Removal

##### Signal Wire

Insert a screwdriver blade between the connector and the wedge lock tab.

Release the locking tab and at the same time, pry the wedge lock to the open position.

**CAUTION:** The wedge lock should never be removed from the connector for insertion or removal of the signal wire terminals.

## Section 11 ELECTRICAL CONNECTORS AND WIRING DIAGRAM

### Subsection 01 (ELECTRICAL CONNECTORS)

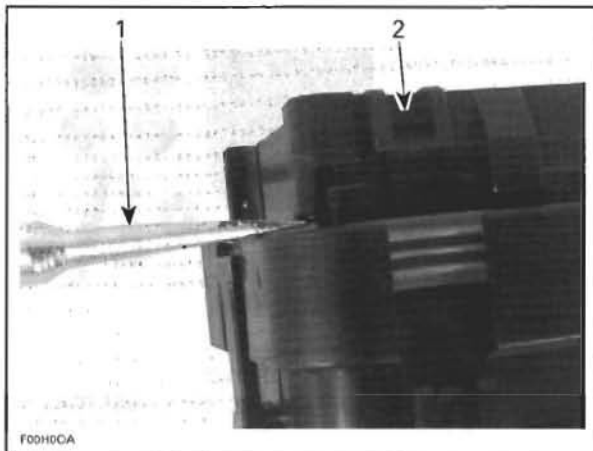

1. Screwdriver between wedge lock and connector
2. Locking tab

Repeat the same steps for the other locking tab retaining the wedge lock.

The wedge lock is now in the open position.

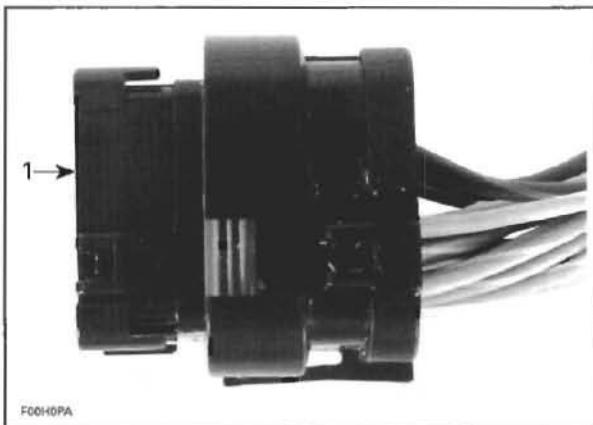

1. Wedge lock opened

While rotating the wire back and forth over a half turn (1/4 turn in each direction), gently pull the wire until the terminal is removed.

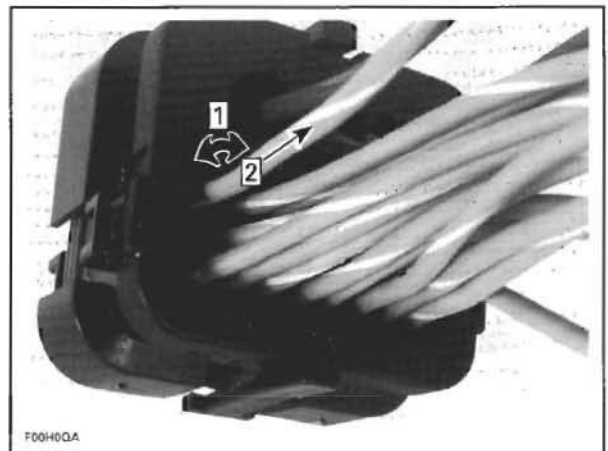

- Step 1: Rotate wire back and forth  
Step 2: Pull wire

#### Power Wire Terminal

**NOTE:** The wedge lock must be removed to extract power terminal.

Open the wedge lock.

Pull both locking tabs and remove wedge lock from connector.

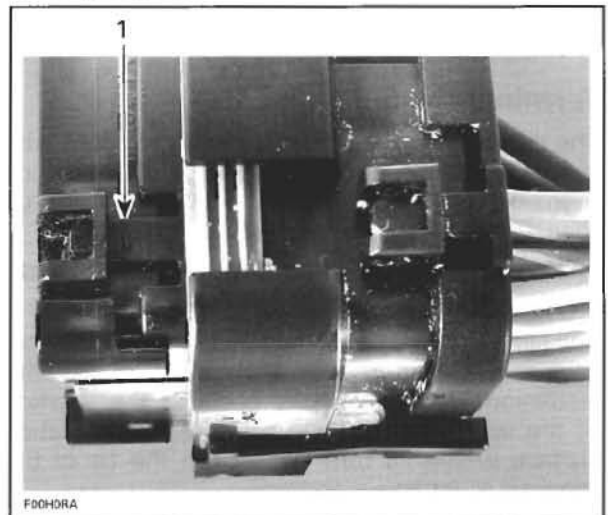

1. Pull locking tab (both sides)

Before extraction, push wire forward to relieve pressure on retaining tab.

Insert a 4.8 mm (.189 in) wide screwdriver blade inside the front of the terminal cavity.



## Section 11 ELECTRICAL CONNECTORS AND WIRING DIAGRAM

### Subsection 01 (ELECTRICAL CONNECTORS)

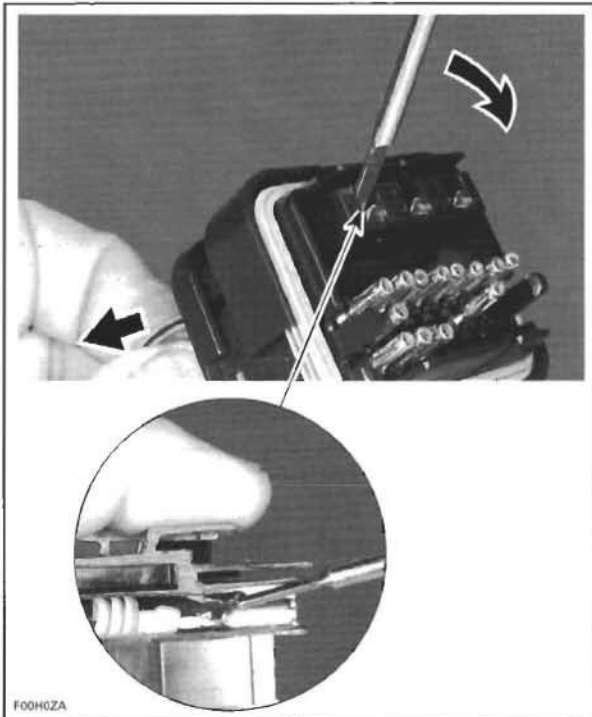

Pry back the retaining tab while gently pulling wire back until terminal is removed.

#### Terminal Crimping

The size of the wires must be 20 to 16 AWG with a wire insulation diameter having a minimum dimension of 1.7 mm (.067 in) and a maximum dimension of 2.78 mm (.106 in).

The wire strip length must be 5.1 mm (13/64 in).

**NOTE:** When stripping wires, ensure conductor is not nicked, scrapped or cut. Wire stripping tool jaws may leave marks on the surface of the wire insulation. If these marks occur at the location of the wire seal, leakage may result. Insulation surface within 25 mm (1 in) from the tip of the terminal must be smooth.

All terminals in AMP connectors must be crimped using the crimping tool (P/N 529 035 909) and crimper die (P/N 529 035 908).

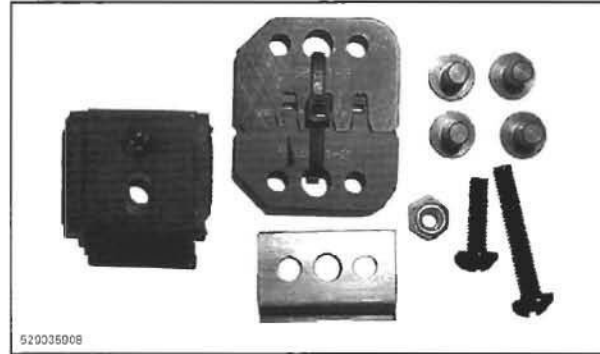
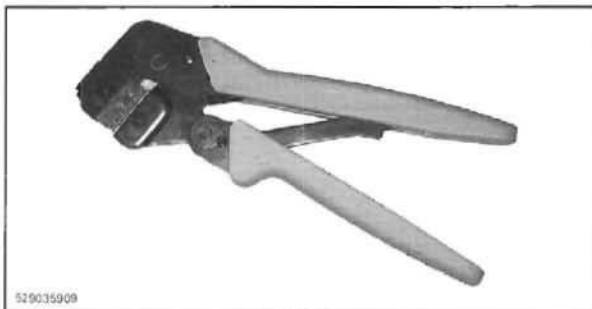

**CAUTION:** If terminals are not crimped using the proper crimping tool, the wire seal may be damaged.

All circuits are sealed by a diaphragm in the rubber wire seal. When installing a terminal in connector, the diaphragm is pierced as the terminal passes through it.

If the diaphragm is pierced and the cavity is not used, install a seal plug, large end first, into circuit cavity as far as it will go.

**NOTE:** It is suggested that all unused circuit cavities be sealed with a seal plug, even if they are not pierced.

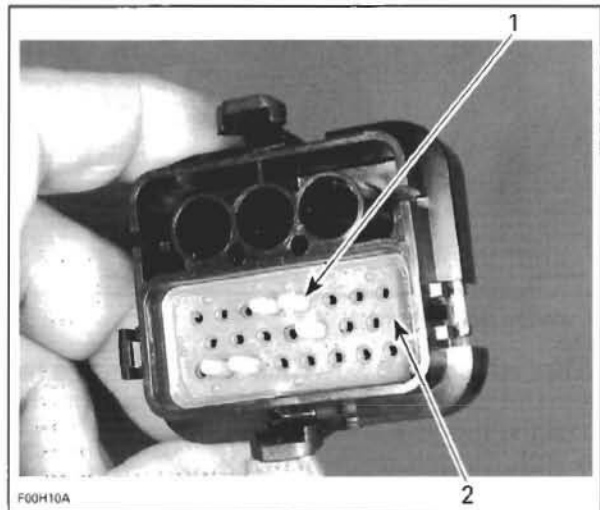

1. Seal plug
2. Wire seal

**CAUTION:** Do not pierce the diaphragm with a sharp point when performing electrical troubleshooting. The resulting pinholes in the insulation will allow moisture to penetrate the system and possibly result in system failure.

#### Terminal Installation

For insertion of signal terminal, make sure the wedge lock is in the open position.

**NOTE:** For insertion of power terminal, the wedge lock may or may not be on the open position.

## Section 11 ELECTRICAL CONNECTORS AND WIRING DIAGRAM

### Subsection 01 (ELECTRICAL CONNECTORS)

Insert terminal into appropriate circuit cavity and push as far as it will go.

Pull back on the terminal wire to be sure the retention fingers in the connector are holding the contact properly.

After all required terminals have been inserted, the wedge lock must be closed to its locked position.

#### Terminal Identification

##### AMP Connectors of MPEM

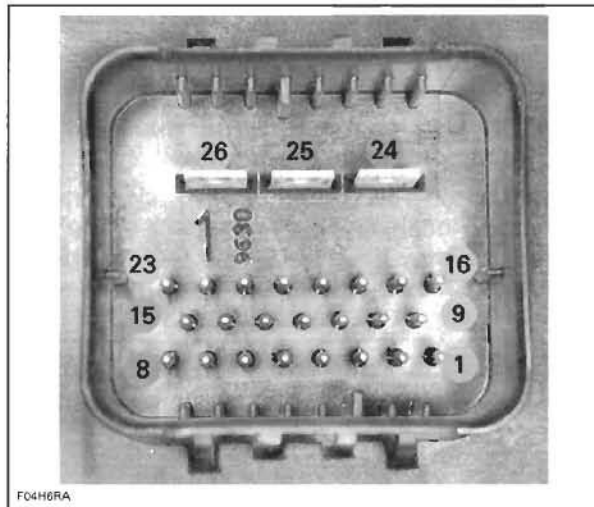

F04H6RA

##### AMP Connectors of Wiring Harness

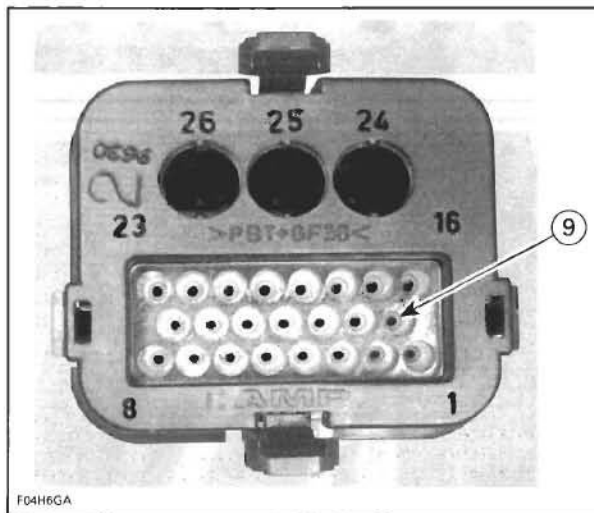

F04H6GA

#### ECM CONNECTORS

There are two ECM connectors used on the 4-TEC models and they are connected on the ECM. The engine harness female connector is connected on the module male connector "A" and the watercraft system control harness female connector is connected to the module male connector "B". The ECM connectors have 41 pins.

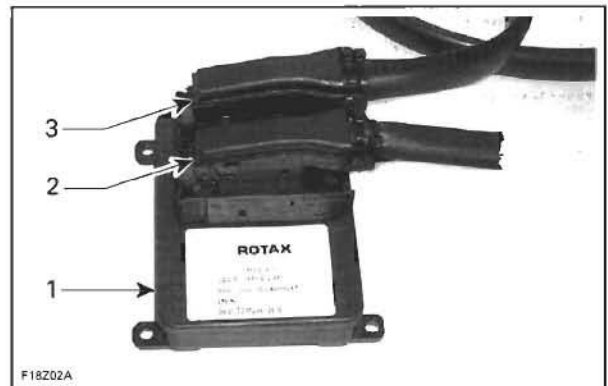

F18Z02A

1. ECM
2. A connector (engine harness)
3. B connector (watercraft harness)

For probing techniques and tool, refer to *ENGINE MANAGEMENT*.

**CAUTION:** Do not disconnect the ECM connectors needlessly. They are not designed to be disconnected/reconnected frequently.

#### Terminal Removal

Unlock the connector cover by pushing in the tabs on top of the connector with a flat screwdriver to be able to flip the top cover up.

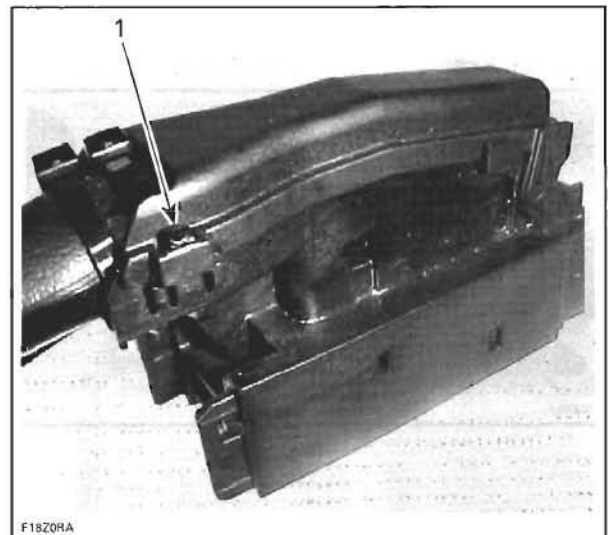

F18Z0RA

1. Push in tab



## Section 11 ELECTRICAL CONNECTORS AND WIRING DIAGRAM

### Subsection 01 (ELECTRICAL CONNECTORS)

Lift the cover by pushing it forward.

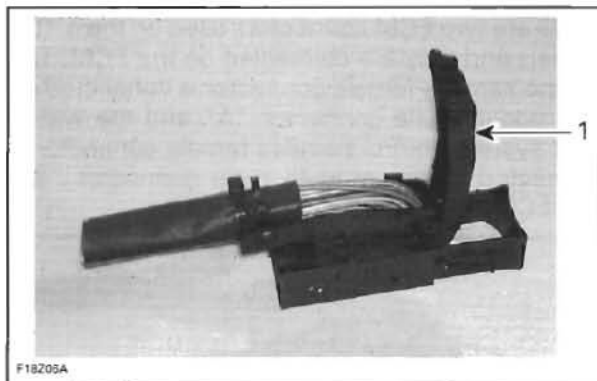

1. Cover

Cut both tie raps that secure the harness to the connector.



1. Tie raps

Turn the connector over and remove the orange locking tab by pushing and then pulling toward the wire harness.

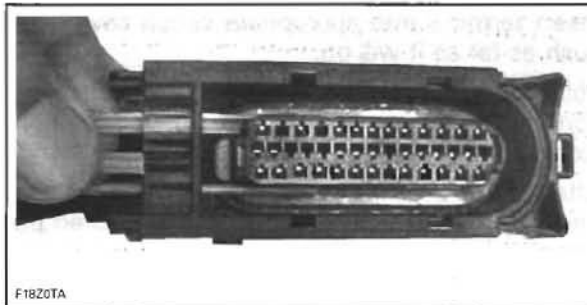

A terminal remover such as Snap-On TT600-1 tool (or a 0.76 mm (.030 in) oxyacetylene torch tip cleaner or a #68 drill bit) must be inserted into the terminal cavity to release the locking tab from the connector.

**CAUTION:** Using a tool tip larger than 0.76 mm (.030 in) may damage the terminal.

Insert the tool tip into the terminal cavity as shown, and locate its wire in the back of the connector. You may have to pry the tool tip against the locking tab to release it, then remove the terminal from the connector.

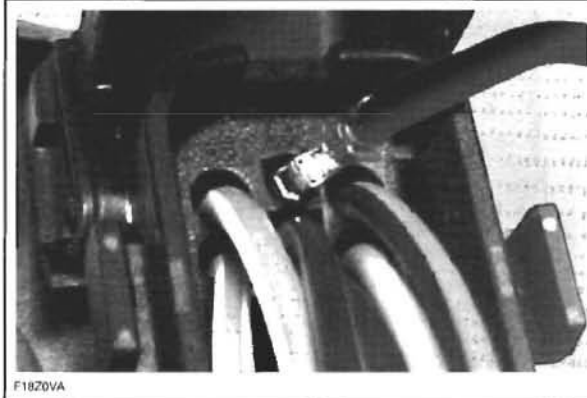
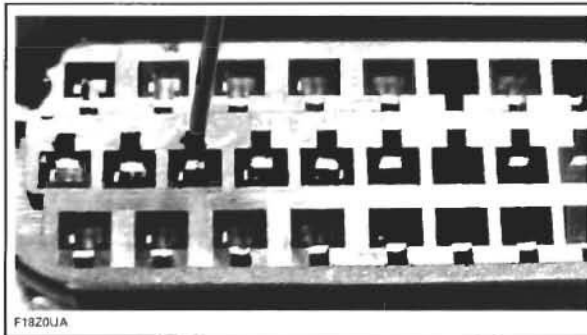

Check the locking tab on the terminal, it may have to be bent out a little so it will lock in its cavity when it is re-inserted.



## Section 11 ELECTRICAL CONNECTORS AND WIRING DIAGRAM

### Subsection 01 (ELECTRICAL CONNECTORS)

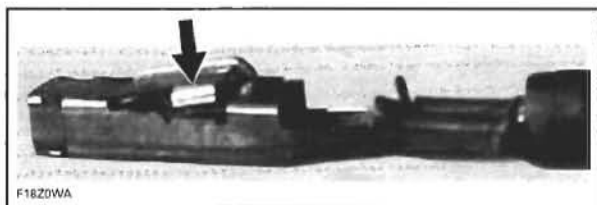

If the wire is in good condition but the terminal is rusted or corroded, remove defective terminal and crimp a new one. If wire and terminal are defective, replace with a new genuine wire and new terminal and crimp them together as explained below.

**IMPORTANT:** Use genuine wires only. Otherwise wires will not fit properly.

When re-inserting the terminal, the locking tab must be installed facing the smaller cutout of the terminal cavity.

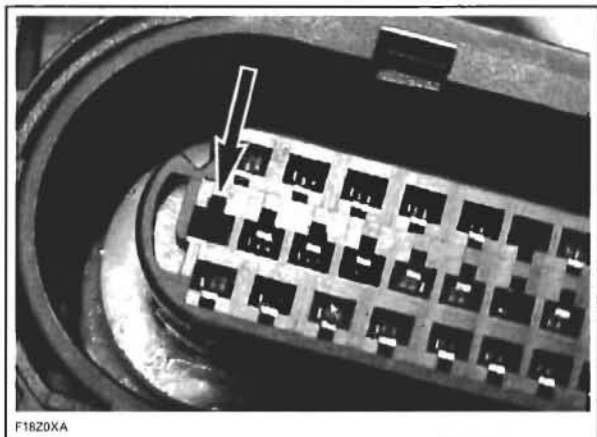

Insert the terminal, ensuring the locking tab snaps into its cavity.

Re-install the orange locking tab, attach the 2 tie raps, and close the connector cover.

#### Terminal Crimping (Kostal)

To crimp a new connector terminal, use the crimping tool (P/N 529 035 909) and the crimper die (P/N 529 035 906).

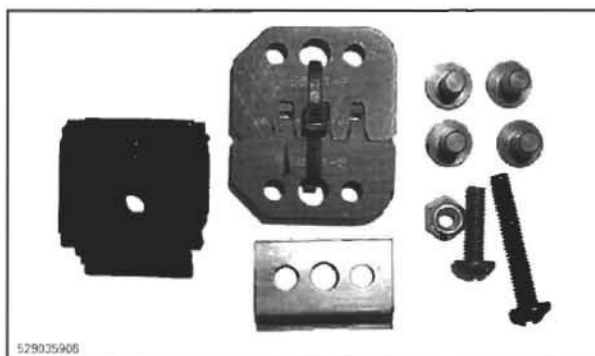
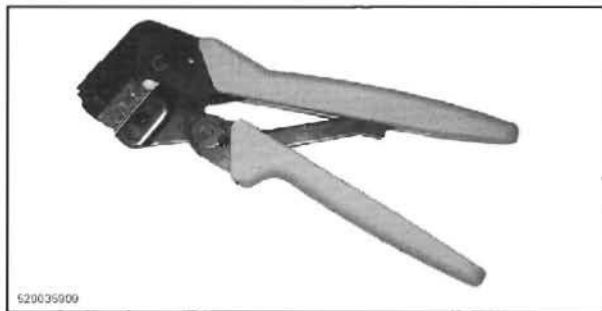

To properly crimp the wires, strictly follow this procedure.

Strip the wire to a maximum of 3 mm (1/8 in).

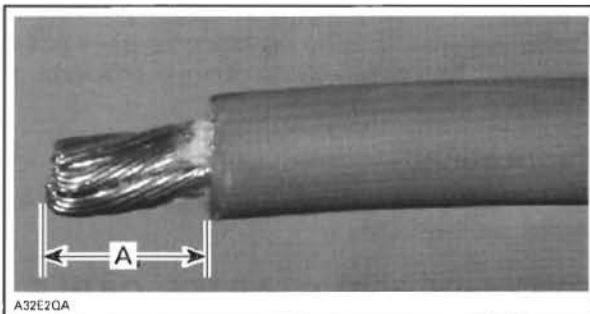

**TYPICAL**  
A. 3 mm (1/8 in) max.

Position wire in terminal.

Squeeze the terminal tabs with your fingers to temporarily retain terminal in place.

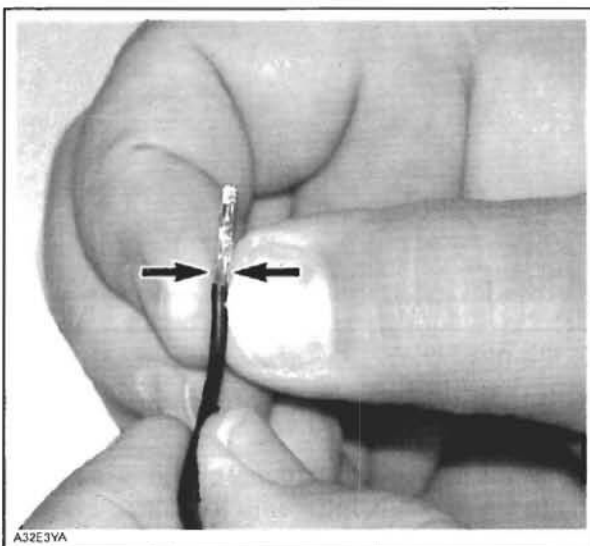

Insert terminal with wire in crimping pliers and position so that top of terminal tabs are flush with pliers edge or a little bit lower as shown.

# Section 11 ELECTRICAL CONNECTORS AND WIRING DIAGRAM

## Subsection 01 (ELECTRICAL CONNECTORS)

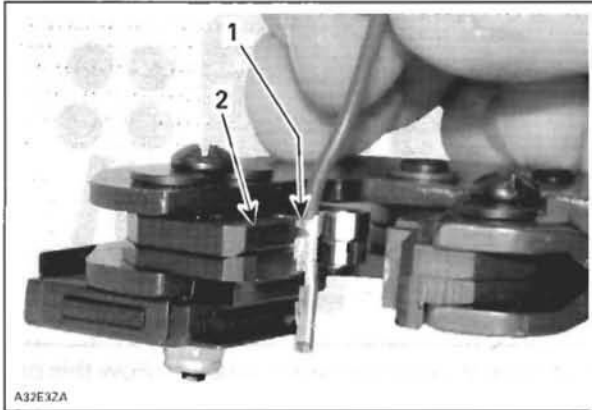

1. Top of terminal tabs
2. Align tabs with pliers edge

Crimp terminal. Ensure no tiny wire goes out of terminal. This might cause strange problems of the electrical system.

### Lubrication

Do not apply any product to the pins of the connector on the ECM.

## BATTERY AND STARTER CABLE TERMINALS

### Crimping

Carefully strip the wire approximately to 10 mm (3/8 in) in length, using a wire stripping tool or sharp blade/knife.

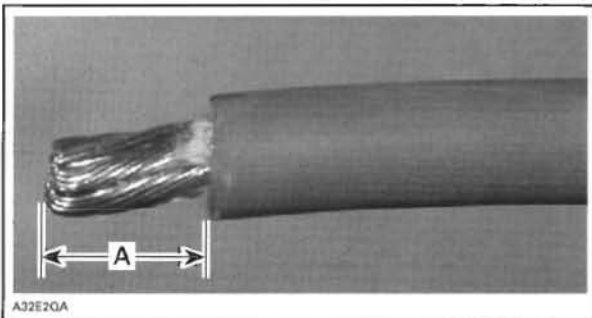

- A. 10 mm (3/8 in)

**NOTE:** Make sure not to cut wire strands while stripping the wire.

Install the appropriate terminal on the wire according to the requirement. Refer to appropriate parts catalog.

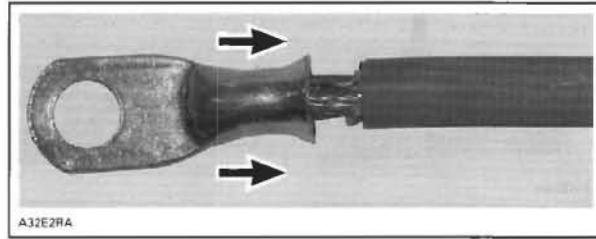

### INSTALLATION OF TERMINAL

Follow the instructions provided with the crimping pliers (P/N 529 035 730) to select the proper position of the tool.



**NOTE:** Different wires require different crimping pliers settings, so make sure to follow the instruction supplied with the tool.

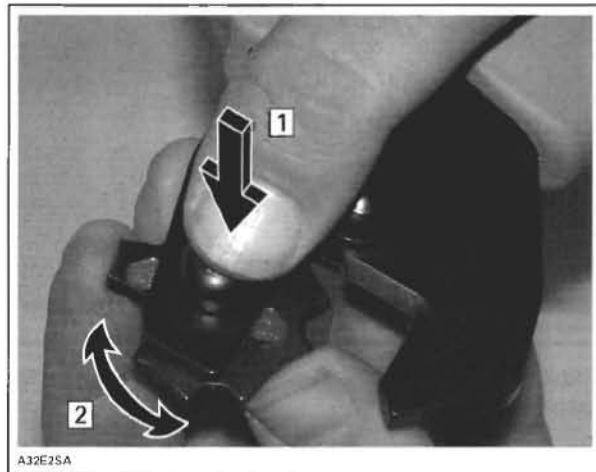

### POSITIONING THE CRIMPING PLIERS

- Step 1: Press  
Step 2: Rotate

After positioning the crimping pliers, crimp the terminal already installed on wire.

---

## Section 11 ELECTRICAL CONNECTORS AND WIRING DIAGRAM

### Subsection 01 (ELECTRICAL CONNECTORS)

---

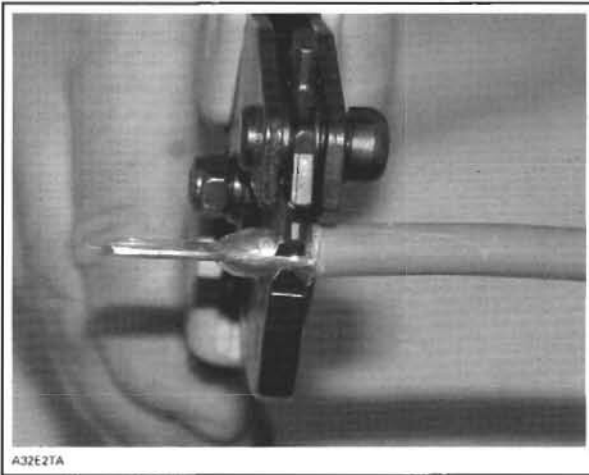

A32E2TA

*CRIMPING OF WIRE*

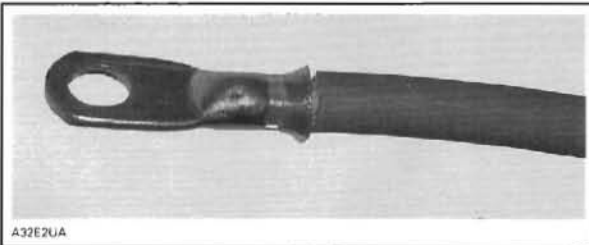

A32E2UA

*PROPERLY CRIMPED WIRE*

To verify, if the wire is properly crimped, apply some pulling force on wire and the terminal at the same time from both directions.

**CAUTION:** Never weld the wire to the terminal. Welding can change the property of the wire and it can become brittle and break.

Install the protective heat shrink rubber tube on the terminal. Heat the heat shrink rubber tube using the heat gun so that it grasps the wire and the terminal.

**CAUTION:** Make sure that the protective heat shrink rubber tube has been properly installed and no part of wire is exposed.





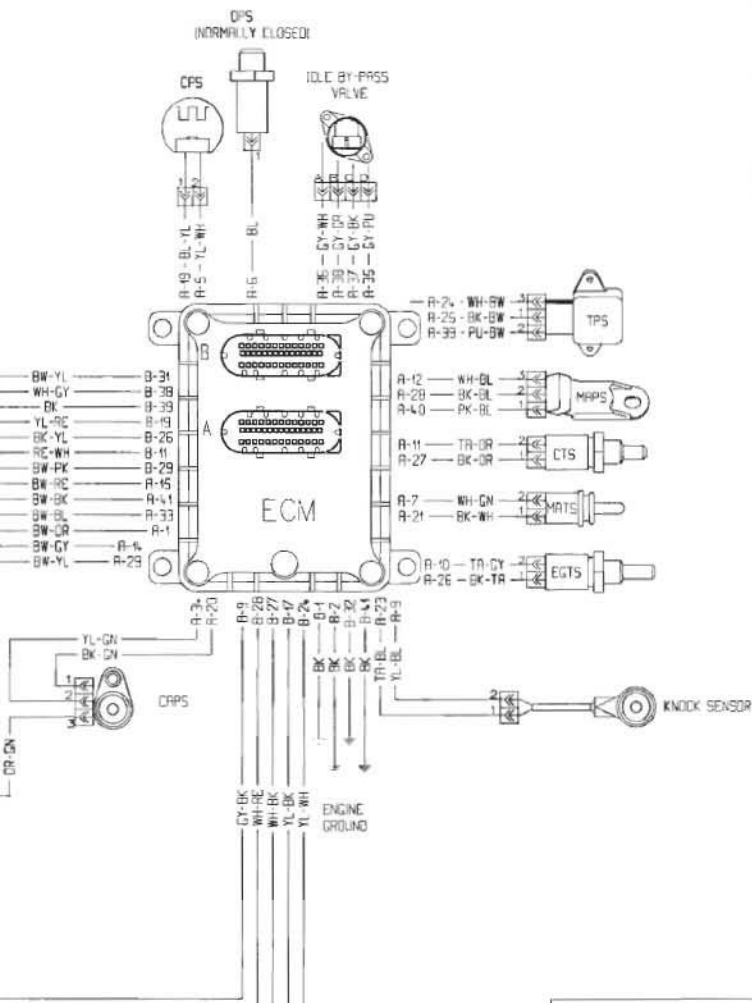
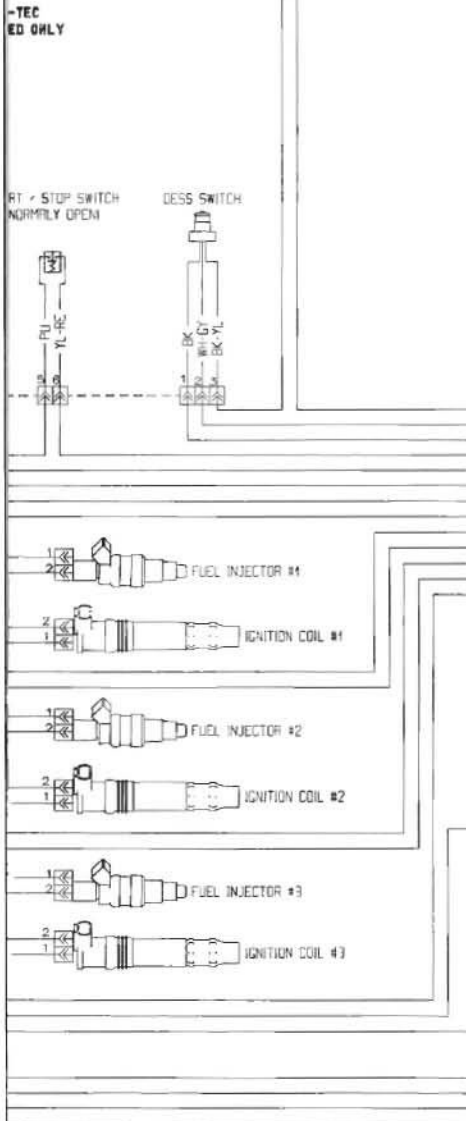
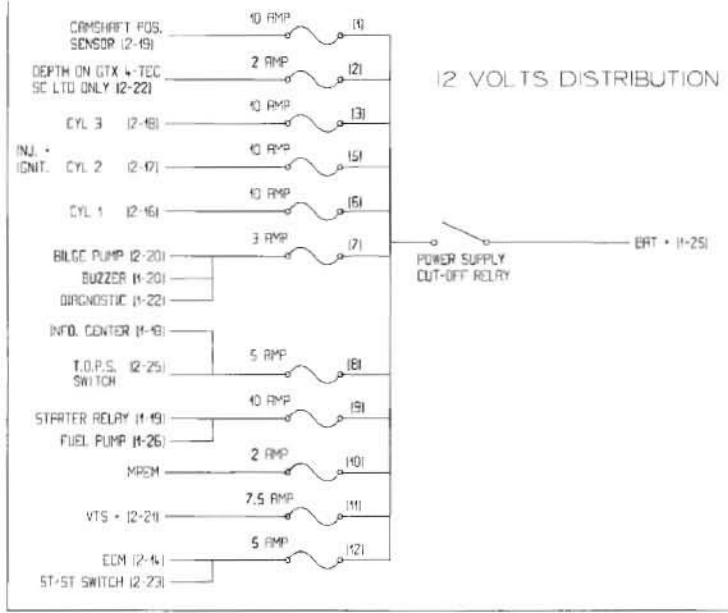
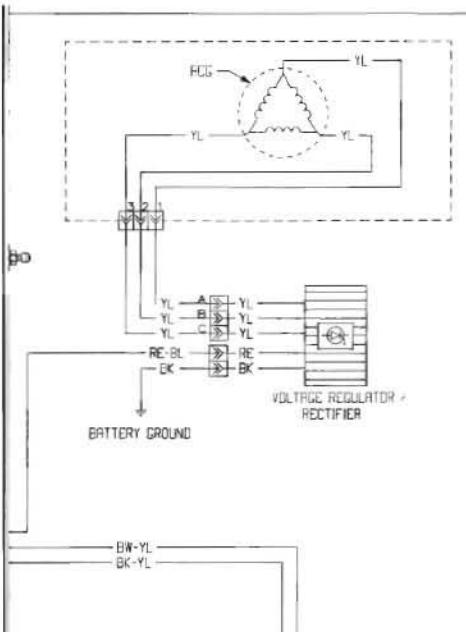

COLOR CODE	
WH - WHITE	BK - BLACK
RE - RED	YL - YELLOW
PU - PURPLE	TR - TAN
GN - GREEN	BW - BROWN
CY - GREY	BL - BLUE
PK - PINK	OR - ORANGE



**WARNING**

ENSURE ALL TERMINALS ARE PROPERLY CRAMPED ON THE WIRES AND ALL CONNECTOR HOUSING ARE PROPERLY FASTENED.

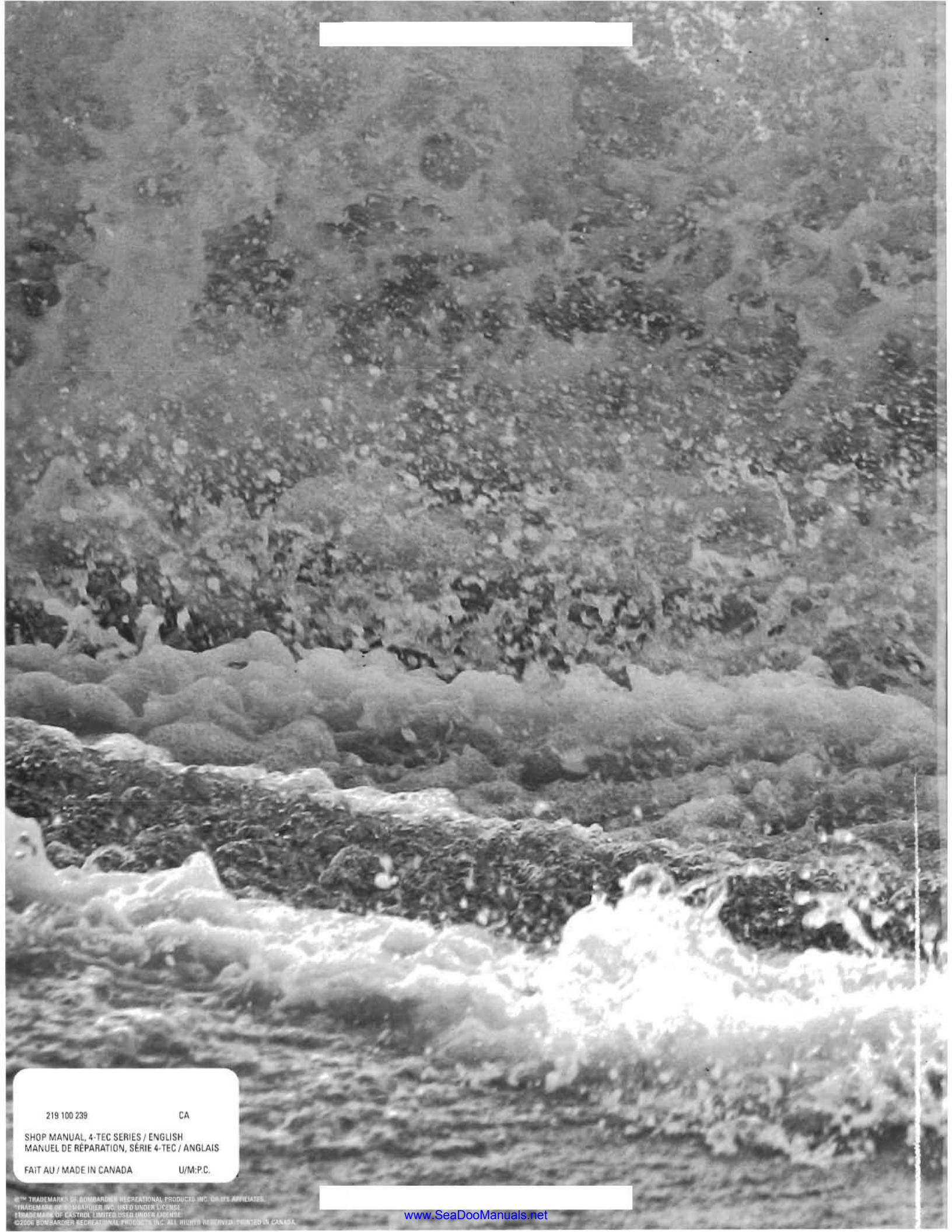

219 100 239

CA

SHOP MANUAL, 4-TEC SERIES / ENGLISH  
MANUEL DE RÉPARATION, SÉRIE 4-TEC / ANGLAIS

FAIT AU / MADE IN CANADA

U/M:P.C.



®™ TRADEMARKS OF BOMBARDIER RECREATIONAL PRODUCTS INC. OR ITS AFFILIATES.  
\*TRADEMARK OF BOMBARDIER INC. USED UNDER LICENSE.  
†TRADEMARK OF CASTROL LIMITED USED UNDER LICENSE.  
©2006 BOMBARDIER RECREATIONAL PRODUCTS INC. ALL RIGHTS RESERVED. PRINTED IN CANADA.

[www.SeaDooManuals.net](http://www.SeaDooManuals.net)