

ROTAX®



2006

ENGINE
SHOP
MANUAL

ROTAX®
V-810

219 100 230

2006 Engine Shop Manual

ROTAX® V-810 ENGINES

BOMBARDIER* ATV



TABLE OF CONTENTS

SAFETY NOTICE	III
INTRODUCTION	IV
GENERAL INFORMATION	IV
ENGINE EMISSIONS INFORMATION	IV
ENGINE IDENTIFICATION NUMBER (E.I.N.)	IV
CYLINDERS IDENTIFICATION	IV
TIGHTENING TORQUES	IV
ARRANGEMENT OF THIS MANUAL, ILLUSTRATIONS AND PROCEDURES	V
01 V-810 ENGINE	1
01 - LEAK TEST	1
GENERAL	1
PROCEDURES	1
PREPARATION	1
REASSEMBLY	3
02 - COOLING SYSTEM	5
GENERAL	7
PROCEDURES	7
WATER PUMP HOUSING	7
WATER PUMP IMPELLER	8
WATER PUMP SHAFT	8
03 - LUBRICATION SYSTEM	11
GENERAL	13
PROCEDURES	13
ENGINE OIL PRESSURE TEST	13
ENGINE OIL PRESSURE REGULATOR	13
OIL PUMP	14
ENGINE OIL STRAINER	16
REED VALVE	17
04 - MAGNETO SYSTEM	19
GENERAL	21
PROCEDURES	21
MAGNETO COVER	21
STATOR	22
ROTOR	23
SPRAG CLUTCH	24
SPRAG CLUTCH GEAR	24
STARTER DRIVE GEARS	25
05 - CYLINDER AND HEAD	27
FRONT CYLINDER HEAD (NO. 1)	28
REAR CYLINDER HEAD (NO. 2)	29
CYLINDERS AND PISTONS	30
GENERAL	31
PROCEDURES	31
SPARK PLUG	31
VALVE ADJUSTMENT	32
VALVE COVER	32
CHAIN TENSIONER	33
CAMSHAFT TIMING GEAR	33
CRANKSHAFT LOCKING AND CAMSHAFT TIMING PROCEDURE	35
ROCKER ARM	38
TIMING CHAIN	40
CYLINDER HEAD	40
CAMSHAFT	42
VALVE SPRING	44

2005
 Engine Shop Manual

Legal deposit:

National Library of Quebec
 National Library of Canada 2005

All rights reserved. No parts of this manual may be reproduced in any form without the prior written permission of Bombardier Recreational Products Inc. (BRP).

© Bombardier Recreational Products Inc. (BRP) 2005

Technical Publications
 Bombardier Recreational Products Inc. (BRP)
 Valcourt (Quebec) Canada

Printed in Canada

®™ Trademarks of Bombardier Recreational Products Inc. (BRP) or its affiliates.

* Trademark of Bombardier Inc. used under license.

BOMBARDIER LUBE®
 DESSTM
 Rotax®

This document contains the trademarks of the following companies:

Loctite® is a trademark of Loctite Corporation
 Snap-on® is a trademark of Snap-on Tools Corporation
 Molykote® is a trademark of Dow Corning Corporation

© Bombardier Recreational Products Inc.

VALVE	45
VALVE GUIDE REPLACEMENT PROCEDURE	47
CYLINDER	48
PISTON.....	50
PISTON RINGS	54
06 – BOTTOM END	57
GENERAL.....	60
PROCEDURES	60
PTO COVER	60
DRIVE GEARS	63
REED VALVE	64
TIMING CHAIN	64
TIMING CHAIN GUIDE.....	65
CRANKCASE.....	65
CRANKSHAFT	69
07 – TECHNICAL SPECIFICATIONS	75

SAFETY NOTICE

This manual has been prepared as a guide to correctly service and repair the Rotax® V-810 engines. This edition was primarily published to be used by technicians who are already familiar with all service procedures relating to BRP products. Mechanical technicians should attend training courses given by BRP Training Dept.

Please note that the instructions will apply only if proper hand tools and special service tools are used. This Engine Shop Manual uses technical terms which may be slightly different from the ones used in the *PARTS CATALOG*.

It is understood that this manual may be translated into another language. In the event of any discrepancy, the English version shall prevail.

The content depicts parts and/or procedures applicable to the particular product at time of writing. Service and Warranty Bulletins may be published to update the content of this manual. Make sure to read and understand these. It does not include dealer modifications, whether authorized or not by BRP, after manufacturing the product.

In addition, the sole purpose of the illustrations throughout the manual is to assist identification of the general configuration of the parts. They are not to be interpreted as technical drawings or exact replicas of the parts.

The use of BRP parts is most strongly recommended when considering replacement of any component. Dealer and/or distributor assistance should be sought in case of doubt.

The engine and the corresponding components identified in this document should not be utilized on product(s) other than those for which it was designed.

⚠ WARNING

Unless otherwise specified, engine should be turned OFF and cold for all maintenance and repair procedures.

This manual emphasizes particular information denoted by the wording and symbols:

⚠ WARNING

Identifies an instruction which, if not followed, could cause serious personal injury including possibility of death.

CAUTION: Denotes an instruction which, if not followed, could severely damage engine components.

NOTE: Indicates supplementary information needed to fully complete an instruction. Although the mere reading of such information does not eliminate the hazard, your understanding of the information will promote its correct use. Always use common shop safety practice.

BRP disclaims liability for all damages and/or injuries resulting from the improper use of the contents. We strongly recommend that any services be carried out and/or verified by a highly skilled professional mechanic. It is understood that certain modifications may render use of the engine illegal under existing federal, provincial and state regulations.

INTRODUCTION

GENERAL INFORMATION

This Engine Shop Manual covers the Rotax V-810 engine. It should be used in conjunction with the appropriate *VEHICLE SHOP MANUAL*.

The information and component/system descriptions contained in this manual are correct at time of writing. BRP however, maintains a policy of continuous improvement of its products without imposing upon itself any obligation to install them in products previously manufactured.

BRP reserves the right at any time to discontinue or change specifications, designs, features, models or equipment without incurring obligation.

This Shop Manual uses technical terms which may be different from the ones of the *PARTS CATALOGS*.

When ordering parts always refer to the specific model *PARTS CATALOGS*.

ENGINE EMISSIONS INFORMATION

Refer to the appropriate *VEHICLE SHOP MANUAL*.

ENGINE IDENTIFICATION NUMBER (E.I.N.)

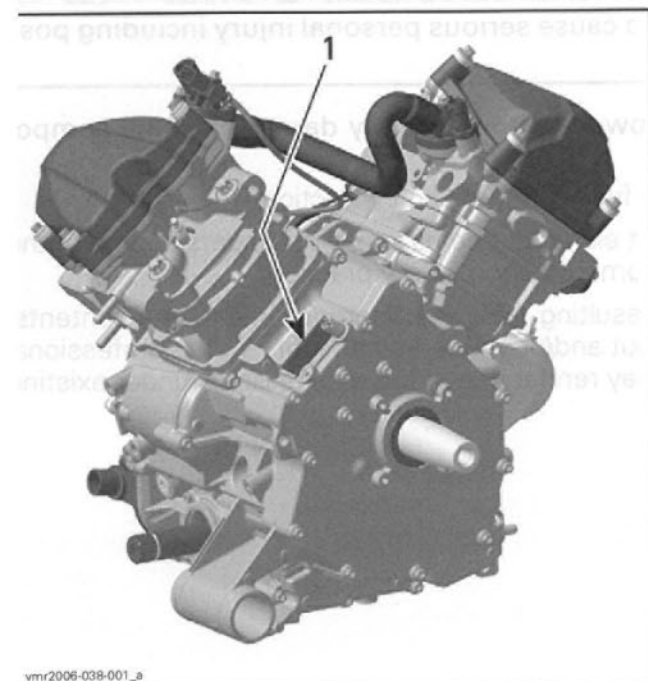

1. Engine Identification Number (E.I.N.)

CYLINDERS IDENTIFICATION

Throughout this Shop Manual, cylinders are referenced as 1 (front) and 2 (rear).

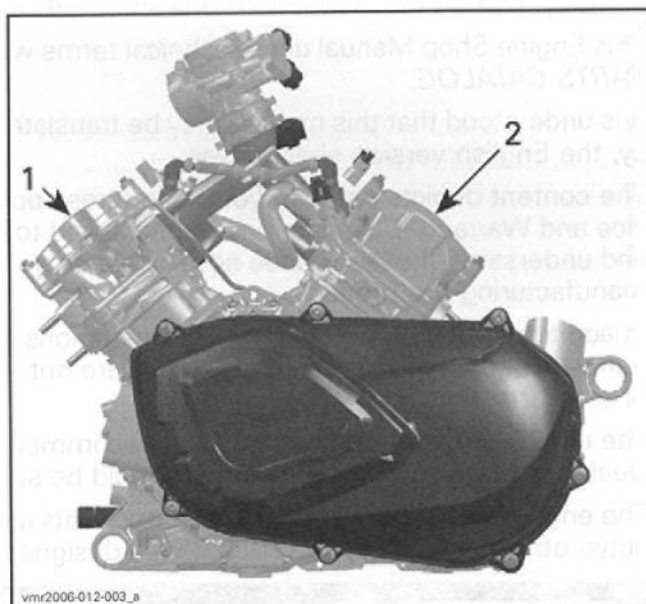

1. Cylinder 1 (front)
2. Cylinder 2 (rear)

TIGHTENING TORQUES

Tighten fasteners to torque mentioned in exploded views and/or text.

⚠ WARNING

Torque wrench tightening specifications must strictly be adhered to. Locking devices (e.g.: locking tabs, elastic stop nuts, self-locking fasteners, etc.) must be installed or replaced with new ones, where specified. If the efficiency of a locking device is impaired, it must be renewed.

ARRANGEMENT OF THIS MANUAL, ILLUSTRATIONS AND PROCEDURES

The manual is divided into many major sections as you can see in the main table of contents at the beginning of the manual.

Each section is divided in various subsections, and again, each subsection has one or more division.

The illustrations show the typical construction of the different assemblies and, in all cases, may not reproduce the full detail or exact shape of the parts shown; however, they represent parts which have the same or a similar function.

CAUTION: These engines are designed with parts dimensioned mostly in the metric system. However some components may be from the imperial system. When replacing fasteners, make sure to use only those recommended by BRP.

As many of the procedures in this manual are inter-related, we suggest that before undertaking any task, you read and thoroughly understand the entire section or subsection in which the procedure is contained.

A number of procedures throughout the book require the use of special tools. Before undertaking any procedure, be sure that you have on hand all the tools required, or approved equivalents.

This Shop Manual uses technical terms which may be slightly different from the ones in the parts catalog.

TYPICAL PAGE

Section 03 ENGINE
Subsection 04 (REMOVAL AND INSTALLATION)

REMOVAL AND INSTALLATION

10 N•m (89 lbf•in)
21 10 N•m (89 lbf•in)
11 N•m (97 lbf•in)
24
13 N•m (115 lbf•in)
19
13 N•m (115 lbf•in)
24 N•m (18 lbf•ft)
13 N•m (115 lbf•in)
19 (115 lbf•in)
48 N•m (35 lbf•ft)
24 N•m (18 lbf•ft)
10 N•m (89 lbf•in)
25
24 N•m (18 lbf•ft)
11
13
15
Synthetic grease
14
48 N•m (35 lbf•ft)
17
11
24 N•m (18 lbf•ft)
10 N•m (89 lbf•in)
28
10 N•m (89 lbf•in)
9
48 N•m (35 lbf•ft)
11
24 N•m (18 lbf•ft)
10 N•m (89 lbf•in)
29 (89 lbf•in)
3
48 N•m (35 lbf•ft)
17
16
17
11
24 N•m (18 lbf•ft)

Drop represents a liquid product to be applied to a surface.

Illustration number for publishing process.

vmr2006-037

Document number for publishing process.

Bold face number indicates special procedure concerning this part.

Page number

Page heading indicates section and subsection detailed.

Subsection title indicates beginning of the subsection.

Exploded view assists you in identifying parts and related positions.

Tightening torque nearby fastener. In this case, nut must be torqued to 10 N•m or 89 lbf•in.

CAUTION: Pay attention to torque specifications. Some of these are in lbf•in instead of lbf•ft. Use appropriate torque wrench.

TYPICAL PAGE

Section 03 ENGINE
Subsection 06 (MAGNETO SYSTEM)

BEARING

Inspection
Ball bearing no. 10 must rotate freely. Otherwise, replace it.

Removal
- Heat up the magneto housing cover to about 100°C (212°F) for an easy ball bearing removal.

1. Ball bearing

Installation
For installation also heat the magneto housing up to about 100°C (212°F) to put ball bearing in place.
Place new ball bearing in freezer for 10 minutes approximately.
Reinstall other removed parts in the reverse order.

STATOR AND TRIGGER COIL

Removal
- Remove.
- magneto housing cover no. 7
- screw no. 11 and 12
- stator with trigger coil no. 13.

1. Stator
2. Stator screws
3. Trigger coil
4. Trigger coil screws

Inspection
Check stator and trigger coil condition. If damaged replace the faulty part.
For electrical inspection, refer to CHARGING SYSTEM for the stator and IGNITION SYSTEM for the trigger coil.

Reference to look up a certain section and subsection. In this case it concerns IGNITION SYSTEM.

Title indicates main procedure to be carried-out.

Call-outs for above illustration.

Bold face number following part name refers to exploded view at beginning of subsection.

138

vmr2006-048

LEAK TEST

SERVICE TOOLS

Description	Part Number	Page
camshaft locking tool.....	529 035 926	2
dial gauge	414 104 700	2

GENERAL

Before performing the cylinder leak test, verify the following:

- clamp(s) tightness
- radiator and hoses.

NOTE: For best accuracy, the leak test should be done with the engine at normal operating temperature.

Repair Tips

- blue exhaust gas means damaged/worn piston rings or valve stem seals
- oily contamination on leak indicator hole means a damaged oil seal on water pump shaft (refer to *COOLING SYSTEM*)
- coolant out of leak indicator hole means a damaged rotary seal on water pump shaft (refer to *COOLING SYSTEM*)
- coolant escaping from water pump housing means damaged gasket(s) and/or loosened screws (refer to *COOLING SYSTEM*).

NOTE: For all the checkpoints mentioned above, see the appropriate engine section to diagnose and repair the engine.

PROCEDURES

NOTE: The following instructions are valid for both cylinders.

PREPARATION

Disconnect battery.

⚠ WARNING

Always respect this order for disassembly; disconnect BLACK (-) cable first.

Remove:

- radiator cap

- any parts to have access to engine cylinder heads. Refer to appropriate *VEHICLE SHOP MANUAL*.

Unplug and remove spark plug cable.
Remove spark plug from cylinder head.

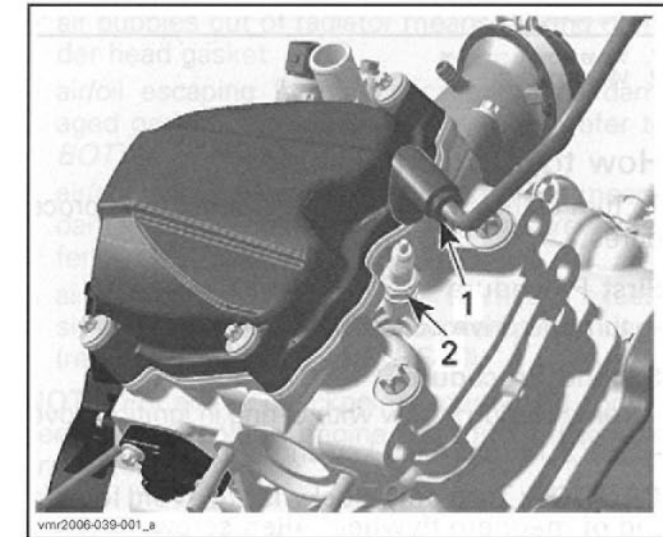

1. Spark plug cable
2. Spark plug

Remove valve cover.

Section 01 V-810 ENGINE
Subsection 01 (LEAK TEST)



1. Valve cover screws
2. Valve cover

How to Turn Crankshaft

To turn crankshaft, there are two possible procedures.

First Procedure

- turn the drive pulley

Second Procedure

- remove plug screw with O-ring in ignition cover
- use a 14 mm Allen-key and turn crankshaft.

CAUTION: Turn only clockwise to avoid loosening of magneto flywheel Allen-screw.

How to Position Piston at TDC

Using a dial gauge (P/N 414 104 700), turn the crankshaft and set the piston to precisely ignition TDC.

NOTE: The engine must be set to precisely ignition TDC; otherwise, the engine will continue to rotate when pressure will be introduced in cylinder.

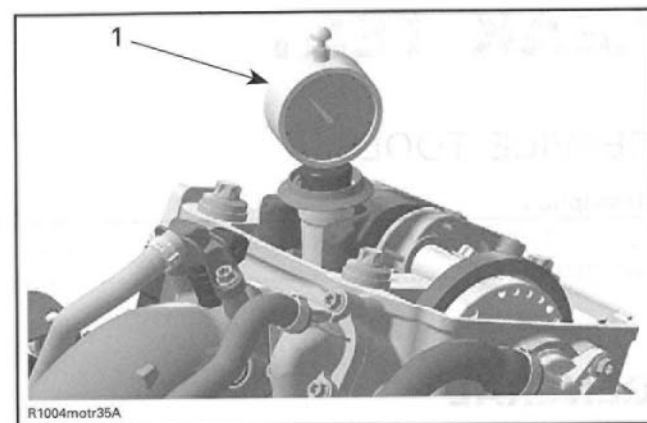

TYPICAL
1. Dial gauge

NOTE: If a dial gauge is not available, use a screwdriver or another similarly suitable tool.

CAUTION: Do not scratch or damage piston/cylinder surface.

NOTE: At ignition TDC the marks on the camshaft timing gear have to be parallel to cylinder head base as per following illustration.

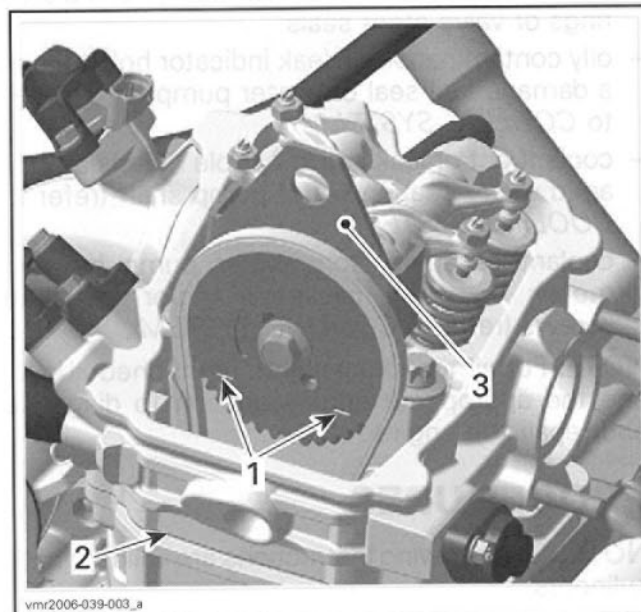

1. Marks on camshaft timing gear
2. Cylinder head base
3. Camshaft locking tool

How to Lock Camshaft

Lock camshaft at TDC by using camshaft locking tool (P/N 529 035 926).

Section 01 V-810 ENGINE
Subsection 01 (LEAK TEST)

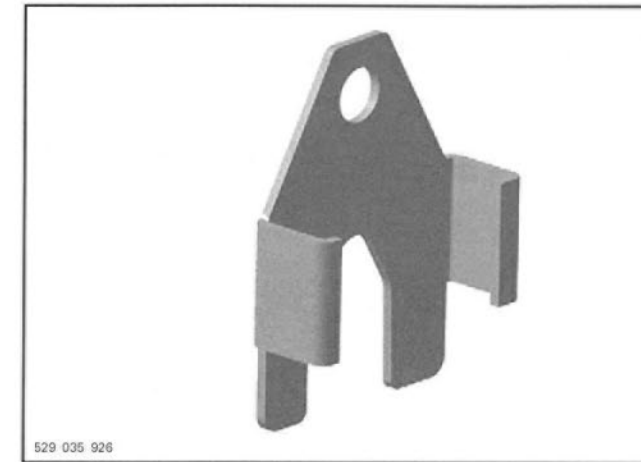

CAMSHAFT LOCKING TOOL

Leak Test

Connect to adequate air supply.

Set needle of measuring gauge to zero.

NOTE: All testers have specific instructions on gauge operation and required pressure.

Install gauge adapter into previously cleaned spark plug hole.

Supply combustion chamber with air pressure.

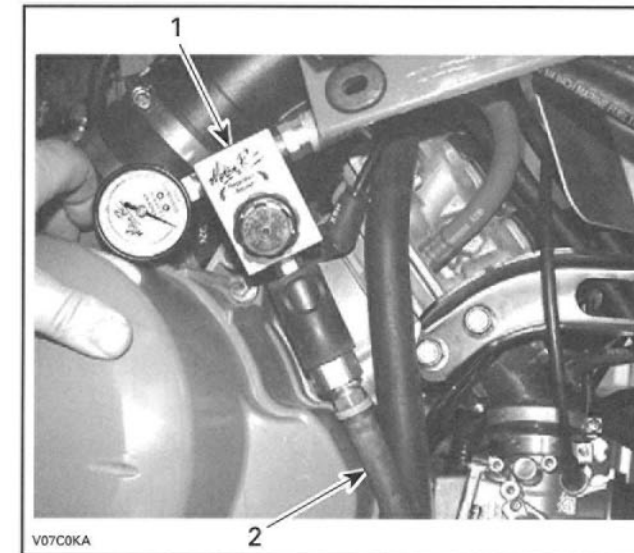

TYPICAL
1. Leak Tester
2. Air supply hose

Note the amount or percentage of leakage (depending on tester).

LEAKAGE PERCENTAGE	ENGINE CONDITION
0% to 15%	Excellent condition
16% to 25%	Good condition
26% to 40%	Fair condition; reduced engine performance.
41% and higher	Poor condition, diagnose and repair engine.

Diagnosis

Listen for air leaks.

- air escaping on intake port/throttle body means leaking intake valve(s)
- air escaping on exhaust port means leaking exhaust valve(s)
- air bubbles out of radiator means leaking cylinder head gasket
- air/oil escaping from crankcase means damaged gasket and/or loosened screws (refer to *BOTTOM END*)
- air/coolant escaping from cylinder/head means damaged gasket(s) and/or loosened screws (refer to *CYLINDER AND HEAD*)
- air escaping into crankcase area means excessively worn cylinder and/or broken piston rings (refer to *CYLINDER AND HEAD*).

NOTE: For all the checkpoints mentioned above, see the appropriate engine section to diagnose and repair the engine.

REASSEMBLY

NOTE: Always replace the valve cover gaskets.

Torque valve cover screws to 7 N•m (62 lbf•in).

Torque spark plugs to 20 N•m (177 lbf•in).

For other components, reverse the preparation procedure. Ensure to respect torque values and use of appropriate products/lubricants. Refer to exploded views of other sections of this manual or to the appropriate *VEHICLE SHOP MANUAL* as required.

COOLING SYSTEM

SERVICE TOOLS

Description	Part Number	Page
installer handle.....	420 877 650	9
oil seal pusher.....	529 035 757	9
water pump ceramic seal installer.....	529 035 766	10

WATER PUMP

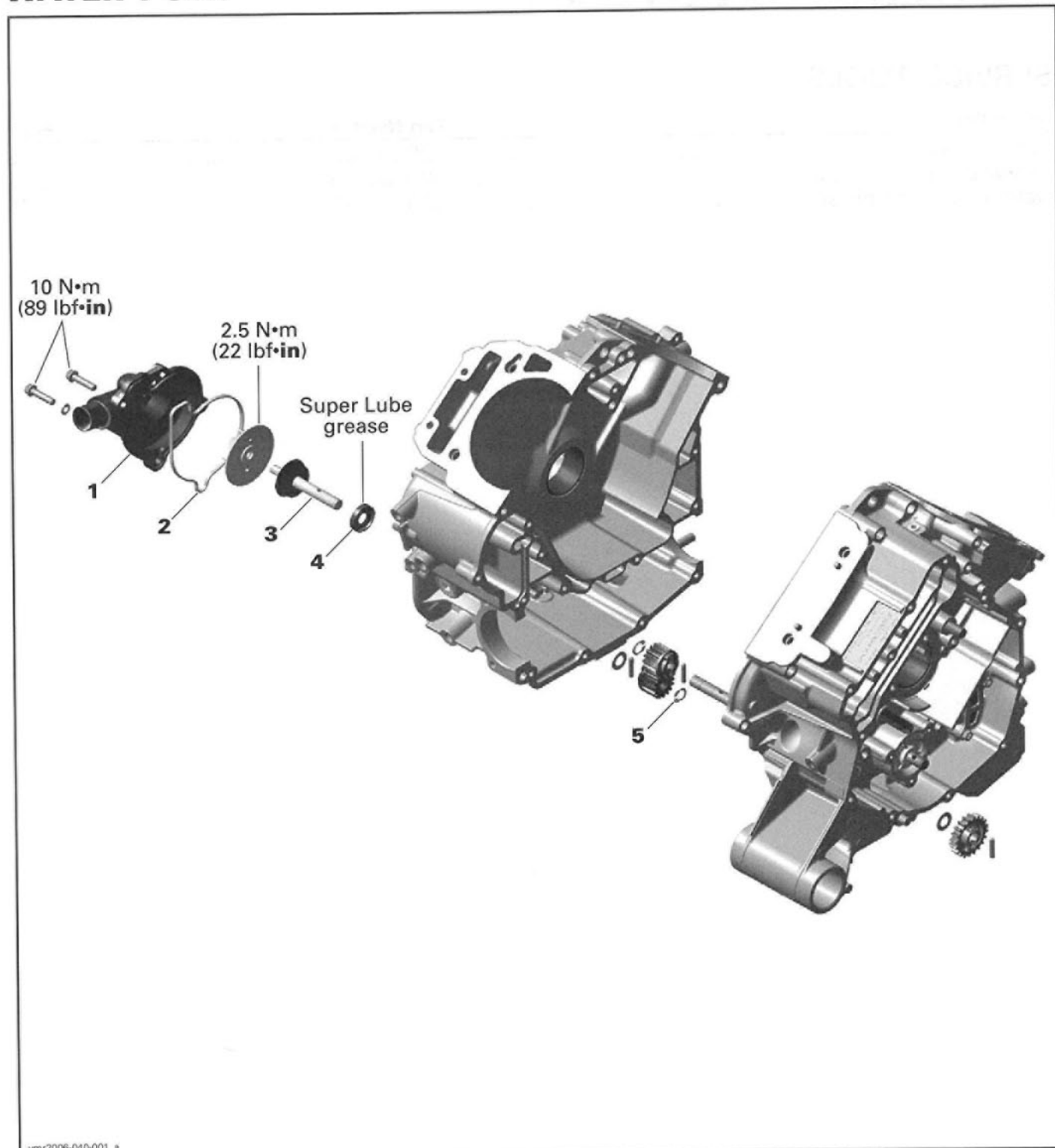

GENERAL

During assembly/installation, use the torque values and service products as in the exploded view. Clean threads before applying a threadlocker. Refer to *SELF-LOCKING FASTENERS* and *LOCTITE APPLICATION* in the *VEHICLE SHOP MANUAL* for complete procedure.

⚠ WARNING

Torque wrench tightening specifications must strictly be adhered to. Locking devices (ex.: locking tabs, elastic stop nuts, self-locking fasteners, etc.) must be installed or replaced with new ones where specified. If the efficiency of a locking device is impaired, it must be renewed.

PROCEDURES

WATER PUMP HOUSING

It is located on the engine MAG side.

Removal

Drain cooling system.

Remove:

- radiator outlet hose from water pump housing
- screws retaining water pump housing

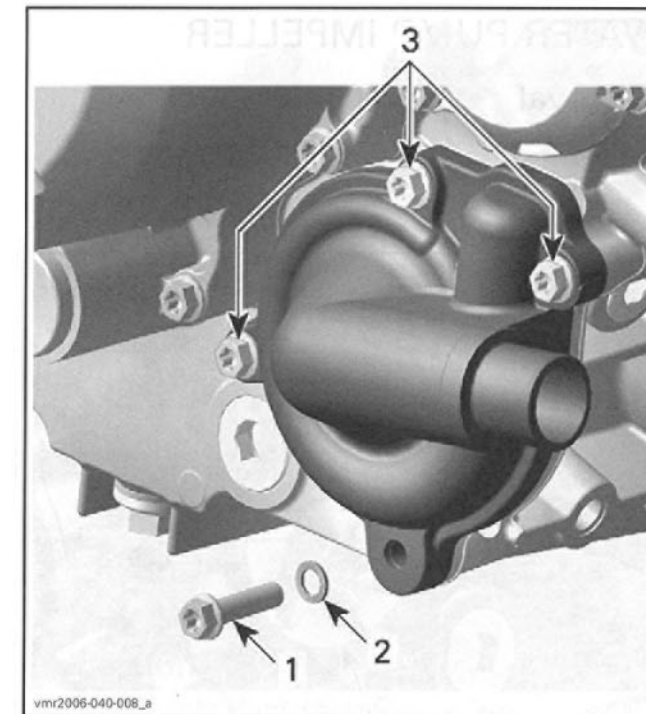

TYPICAL

1. Cooling drain plug M6 x 25
2. Sealing ring
3. Screws M6 x 25

- water pump housing.

Inspection

Check if gasket is brittle, hard or damaged and replace as necessary.

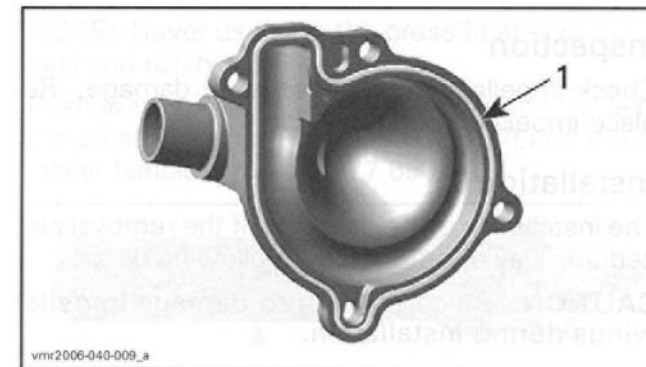

TYPICAL

1. Gasket

Installation

The installation is the opposite of the removal procedure.

CAUTION: To prevent leaking, take care that the gasket is exactly in groove when you reinstall the water pump housing.

Tighten screws of water pump housing in a criss cross sequence.

WATER PUMP IMPELLER

Removal

Remove:

- water pump housing
- impeller.

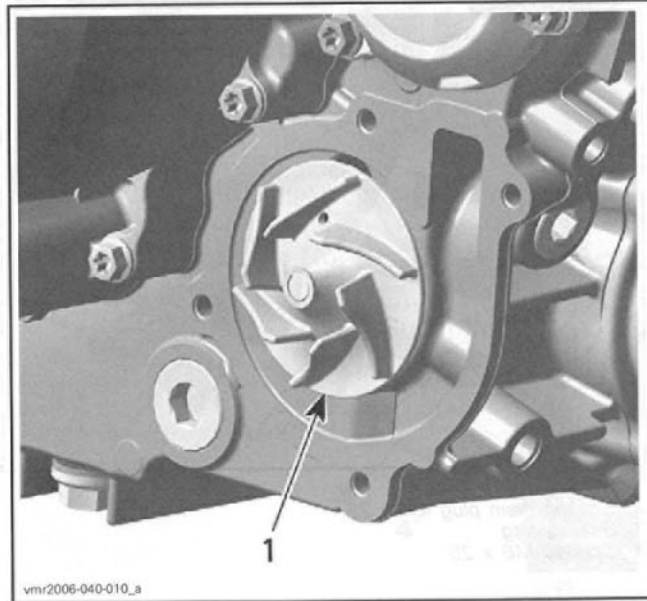

1. Impeller

CAUTION: Water pump shaft no. 3 and impeller no. 2 have right-hand threads. Remove by turning counterclockwise and install by turning clockwise.

Inspection

Check impeller for cracks or other damage. Replace impeller if damaged.

Installation

The installation is the opposite of the removal procedure. Pay attention to the following detail.

CAUTION: Be careful not to damage impeller wings during installation.

WATER PUMP SHAFT

Removal

Remove:

- CVT, refer to appropriate *VEHICLE SHOP MANUAL*
- both cylinders and heads, refer to *CYLINDER AND HEAD*
- separate crankcase, refer to *BOTTOM END*
- water pump housing no. 1
- impeller no. 2
- retaining ring no. 5 with appropriate pliers

CAUTION: Never use the retaining ring a second time. Always install a new one.

- water pump gear

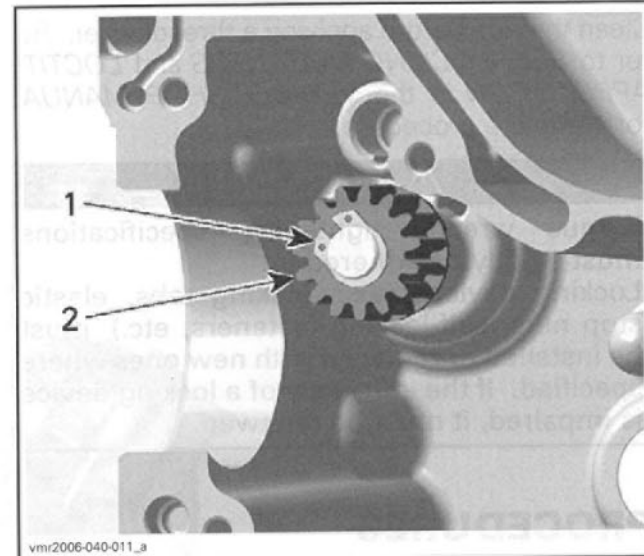

1. Retaining ring
2. Water pump gear

NOTE: The water pump gear is held by a needle pin on the water pump shaft.

- needle pin and thrust washer.

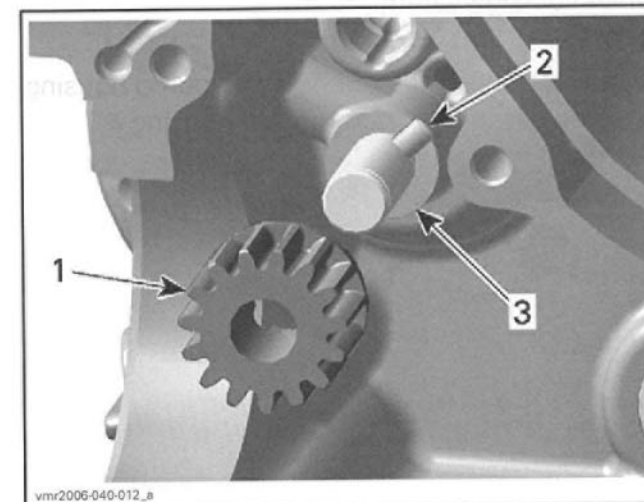

1. Water pump gear
2. Needle pin
3. Thrust washer

Using a soft hammer to push out water pump shaft with rotary seal no. 3 from inside of crankcase MAG side.

CAUTION: When removing water pump shaft, always replace rotary seal with water pump shaft no. 3 and oil seal no. 4 (behind rotary seal).

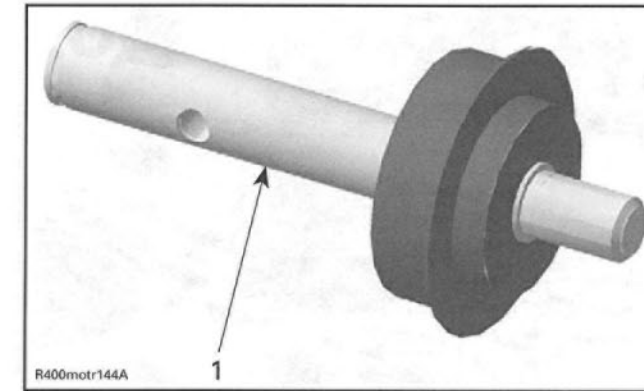

1. Water pump shaft with rotary seal

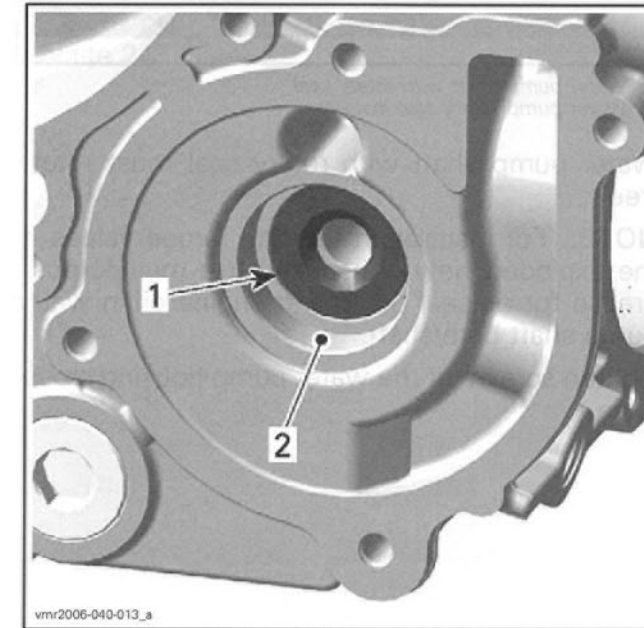

1. Oil seal behind the rotary seal
2. Rotary seal bore

Extract oil seal no. 4 from inside of crankcase MAG side with a pusher.

CAUTION: Be careful not to damage the surface of the rotary seal bore in crankcase MAG side.

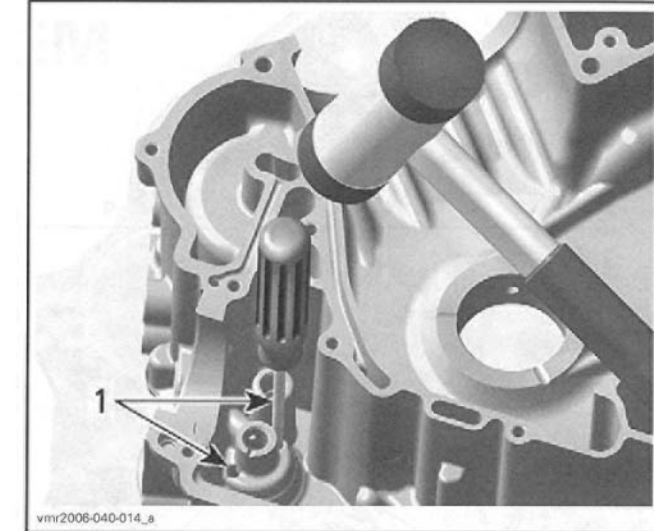

TYPICAL
1. Bores for oil seal removal

Inspection

Inspect water pump gear for wear and damage on the snap mechanism to the needle pin. Replace if damaged.

NOTE: When removing water pump shaft, always replace together retaining ring, oil seal, water pump shaft with rotary seal with new parts.

Installation

For installation, reverse the removal procedure. However, pay attention to the following.

NOTE: Never use oil in the press fit area of the oil seal and rotary seal.

Push water pump shaft oil seal in place by using the oil seal pusher (P/N 529 035 757) and the installer handle (P/N 420 877 650).

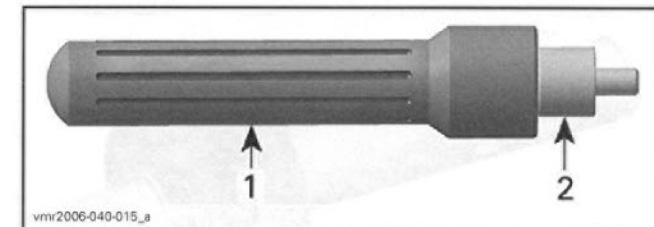

1. Handle
2. Pusher

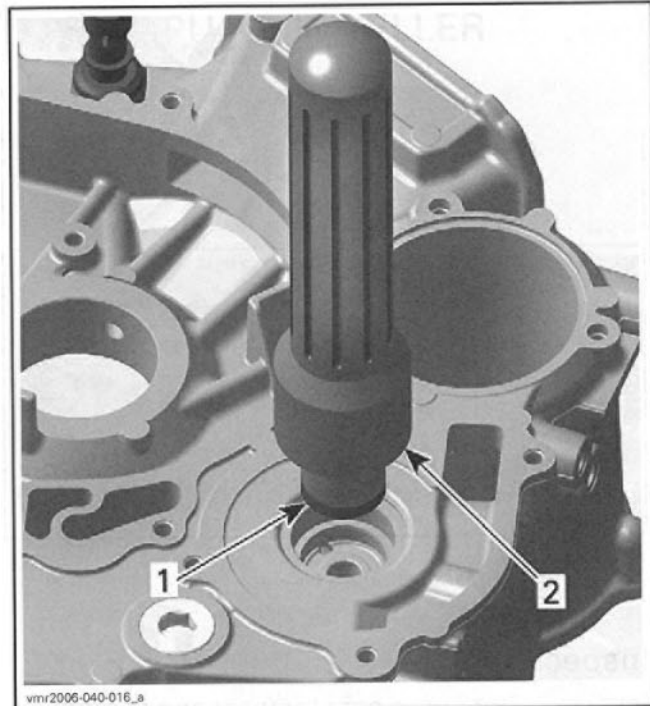

1. Oil seal for the water pump shaft
2. Installer handle with oil seal pusher

It is recommended to install the water pump shaft assembly using the water pump ceramic seal installer (P/N 529 035 766).



NOTE: The water pump shaft assembly has to be pushed using the outside area of the rotary seal.

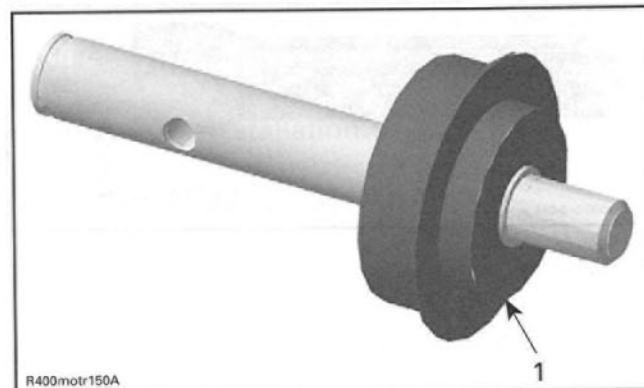

1. Surface to push water pump shaft assembly in place

CAUTION: Never use a hammer for the rotary seal installation. Only use a press to avoid damaging the ceramic component.

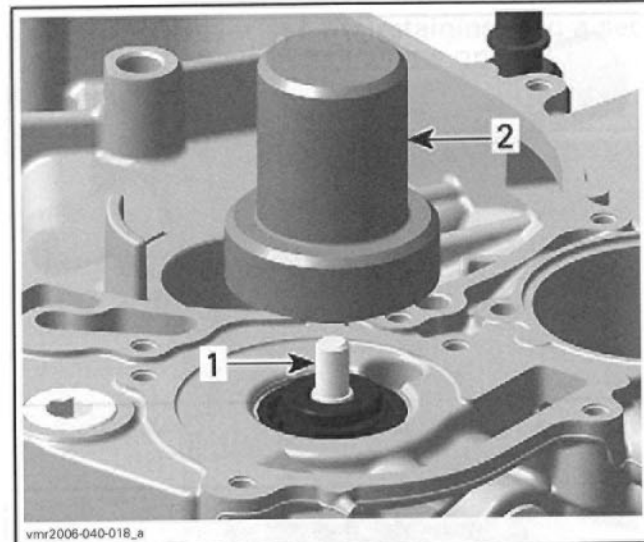

1. Water pump shaft with rotary seal
2. Water pump rotary seal installer

Water pump shaft with rotary seal must rotate freely.

NOTE: For installation use the torque values in the exploded view. Ensure to use multipurpose grease for oil seal no. 4 and engine oil in water pump shaft bore/shaft.

Tighten screws of the water pump housing cross-wise.

LUBRICATION SYSTEM

SERVICE TOOLS

Description	Part Number	Page
disconnect tool	529 035 714	13
hose adapter	529 035 652	13
oil pressure gauge	529 035 709	13

SERVICE PRODUCTS

Description	Part Number	Page
Loctite 243 (blue)	293 800 060	13

Section 01 V-810 ENGINE
Subsection 03 (LUBRICATION SYSTEM)

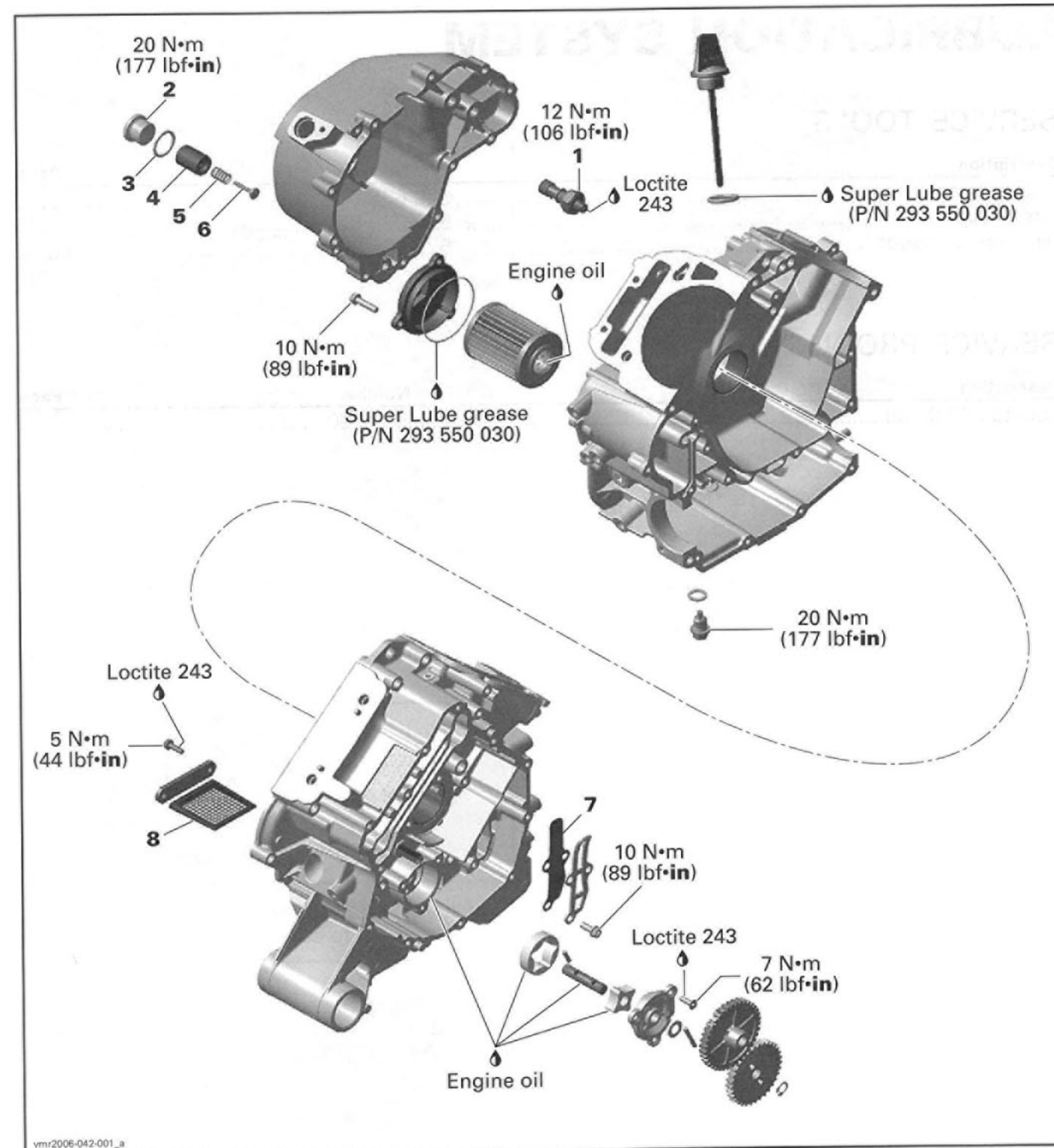

vmr2006-042-001_a

Section 01 V-810 ENGINE
Subsection 03 (LUBRICATION SYSTEM)

GENERAL

For oil change procedure, refer to *LUBRICATION* in the appropriate *VEHICLE SHOP MANUAL*.

PROCEDURES

ENGINE OIL PRESSURE TEST

NOTE: The engine oil pressure test should be done with a warm engine 90°C (194°F) and the recommended oil.

Remove the oil pressure switch no. 1, mounted on the crankcase.

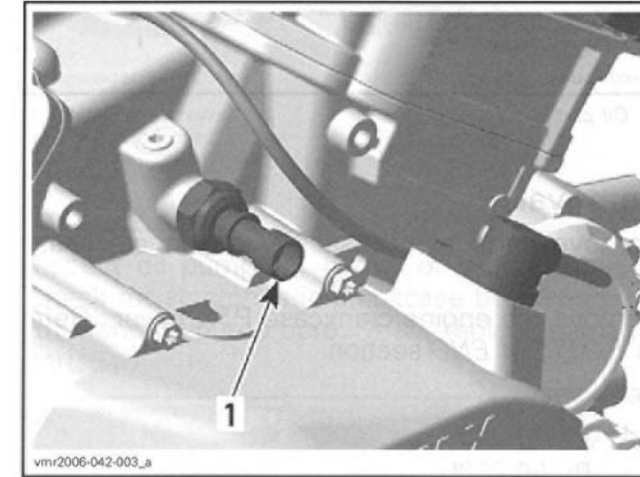

1. Oil pressure switch

Install oil pressure gauge (P/N 529 035 709) and hose adapter (P/N 529 035 652).

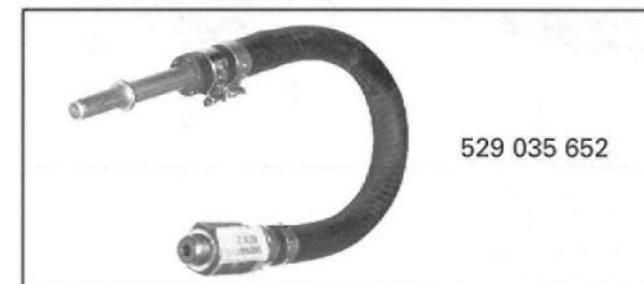

The engine oil pressure should be within the following values.

NOTE: Oil pressure switch works between 20 kPa (2.9 PSI) and 40 kPa (5.8 PSI).

OIL PRESSURE	1250 RPM	6000 RPM
MINIMAL	70 kPa (10 PSI)	350 kPa (51 PSI)
NOMINAL	180 kPa (26 PSI)	420 kPa (61 PSI)
MAXIMAL	300 kPa (43 PSI)	550 kPa (80 PSI)

If the engine oil pressure is out of specifications, check the points described in *TROUBLESHOOTING* section.

To install oil pressure switch, reverse the removal procedure.

NOTE: Install oil pressure switch with Loctite 243 (blue) (P/N 293 800 060).

NOTE: To remove hose adapter from oil pressure gauge, use the disconnect tool (P/N 529 035 714).

ENGINE OIL PRESSURE REGULATOR

The oil pressure regulator is located on the engine magneto side (inside magneto cover).

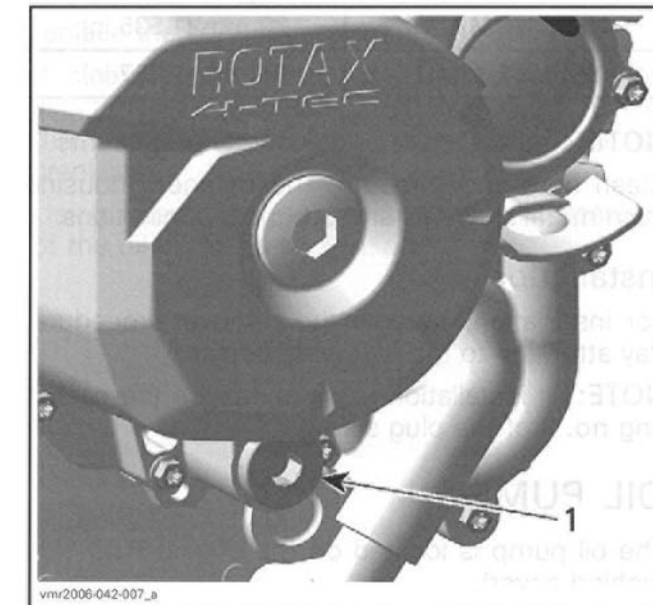

1. Engine oil pressure regulator

NOTE: The oil pressure regulator system works when the oil pressure exceeds 450 kPa (65 PSI).

Removal

Remove plug screw no. 2 and pull oil pressure regulator out.

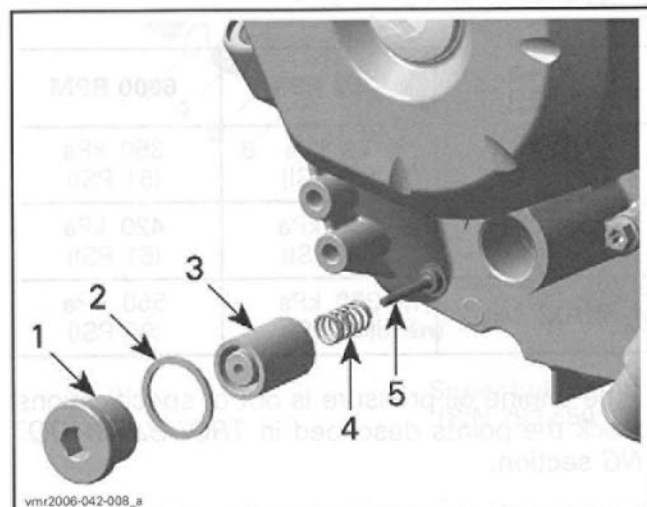

1. Plug screw
2. Gasket ring
3. Pressure regulator housing
4. Spring
5. Pressure regulator valve

Inspection

Inspect pressure regulator housing no. 4 and valve no. 6 for scoring or other damages.

Check spring no. 5 for free length.

SPRING FREE LENGTH	
NEW NOMINAL	39 mm (1.535 in)
SERVICE LIMIT	37 mm (1.457 in)

NOTE: Replace worn or damaged components. Clean bore and thread in the magneto housing from metal shavings and other contaminations.

Installation

For installation, reverse the removal procedure. Pay attention to the following details.

NOTE: At installation, always replace the gasket ring no. 3 of the plug screw.

OIL PUMP

The oil pump is located on the engine PTO side (behind cover).

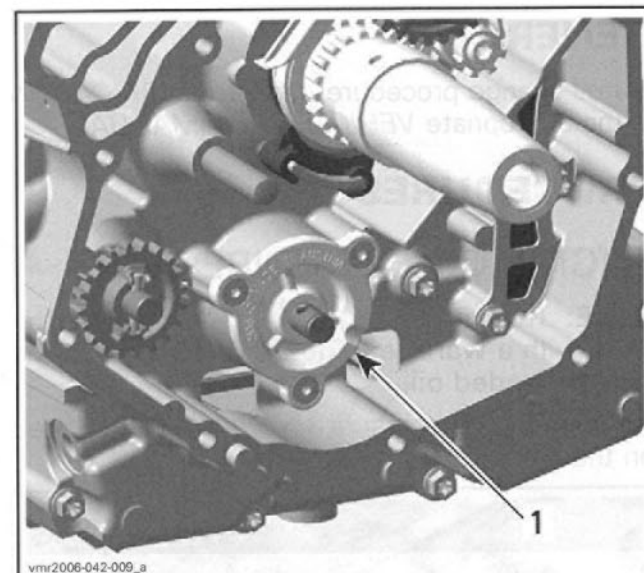

1. Oil pump

Removal

Remove parts to access the engine crankcase PTO cover.

Remove the engine crankcase PTO cover. Refer to *BOTTOM END* section.

Remove:

- retaining ring
- oil pump gear
- needle pin
- thrust washer

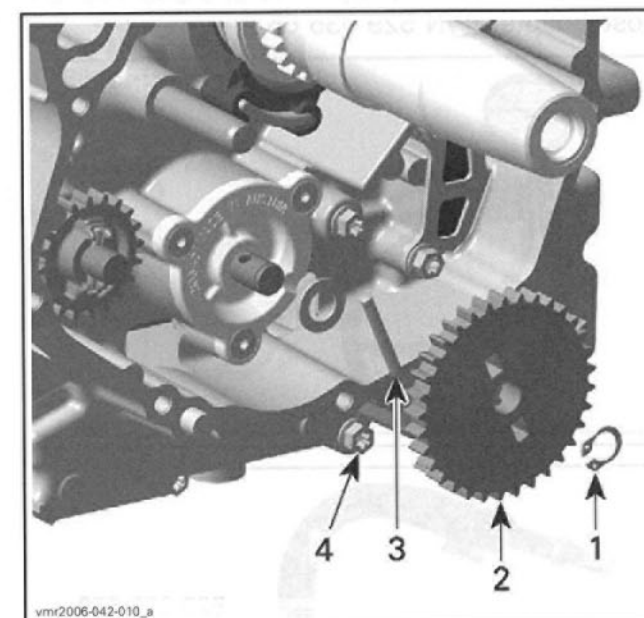

1. Retaining ring
2. Oil pump gear
3. Needle pin
4. Thrust washer

- oil pump cover screws and pull oil pump cover

- oil pump shaft with inner rotor and outer rotor.

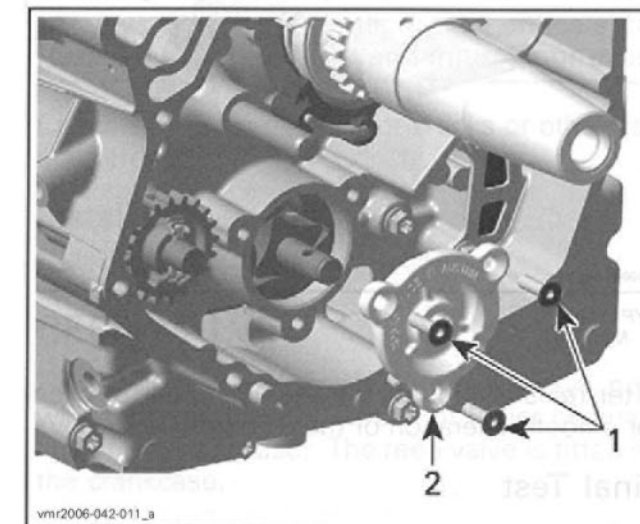

1. Retaining screws
2. Oil pump cover

Inspection

Inspect oil pump for marks or other damages. Check for scratches in crankcase between outer rotor and oil pump bore. If so, replace damaged parts.

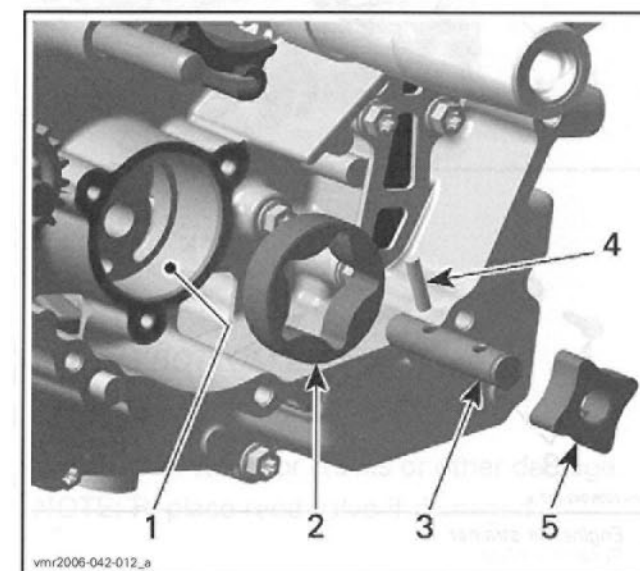

1. Oil pump bore
2. Outer rotor
3. Oil pump shaft
4. Needle pin
5. Inner rotor

Check inner rotor for corrosion pin-holes or other damages. If so, replace oil pump shaft assembly.

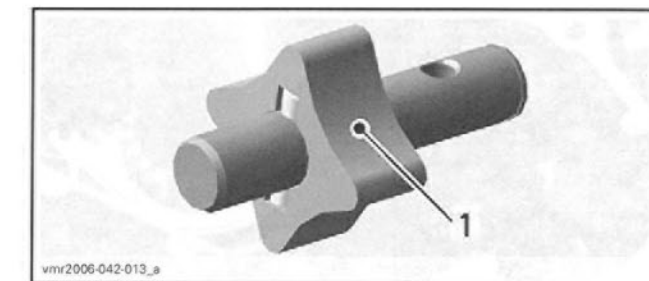

1. Pittings on the teeth

Using a feeler gauge, measure the clearance of inner and outer rotors as shown.

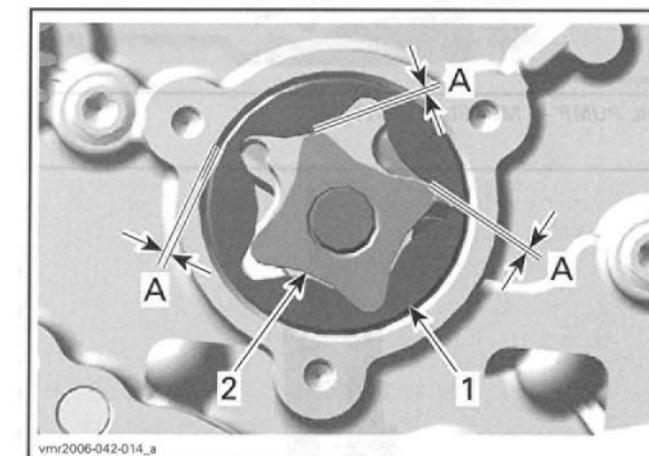

1. Outer rotor
2. Inner rotor
- A. SERVICE LIMIT: 0.25 mm (.009 in)

If clearance of inner and outer rotors exceeds the tolerance, replace oil pump shaft assembly. Ensure to also check oil pump cover. If damaged, replace the complete oil pump assembly.

If clearance between outer rotor and its bore in crankcase exceeds the tolerance, replace the complete oil pump assembly and/or the crankcase.

Using a depth gauge, measure the axial clearance of the oil pump as shown.

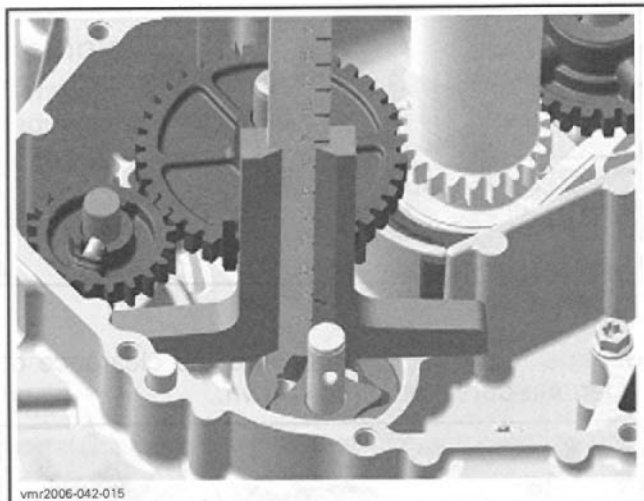

vmr2006-042-015

OIL PUMP — MEASUREMENT "A"

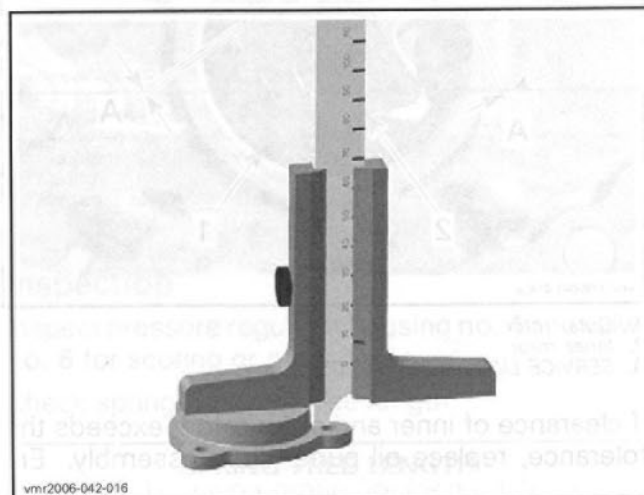

vmr2006-042-016

OIL PUMP COVER — MEASUREMENT "B"

Difference between measurements should not exceed 0.2 mm (.008 in). If so, replace the complete oil pump assembly.

NOTE: When the axial clearance of the oil pump shaft assembly increases, the oil pressure decreases.

Installation

For installation, reverse the removal procedure.

Pay attention to the following details.

NOTE: The outer rotor and inner rotor are marked. When installing, make sure both markings are on the upper side.

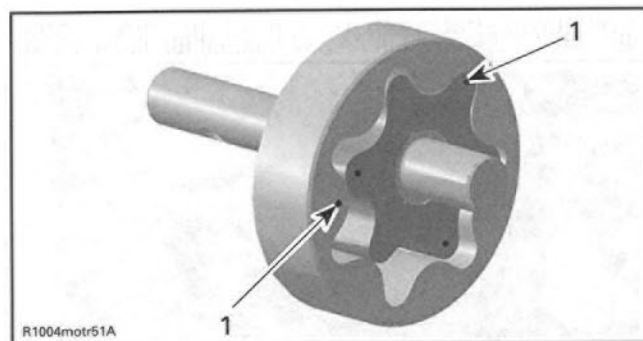

R1004motr51A

TYPICAL
1. Markings

After reinstallation of the remaining parts, check for smooth operation of the oil pump assembly.

Final Test

After engine is completely reassembled, start engine and make sure oil pressure is within specifications (refer to OIL PRESSURE TEST above).

ENGINE OIL STRAINER

The engine oil strainer no. 7 is located between both crankcase halves.

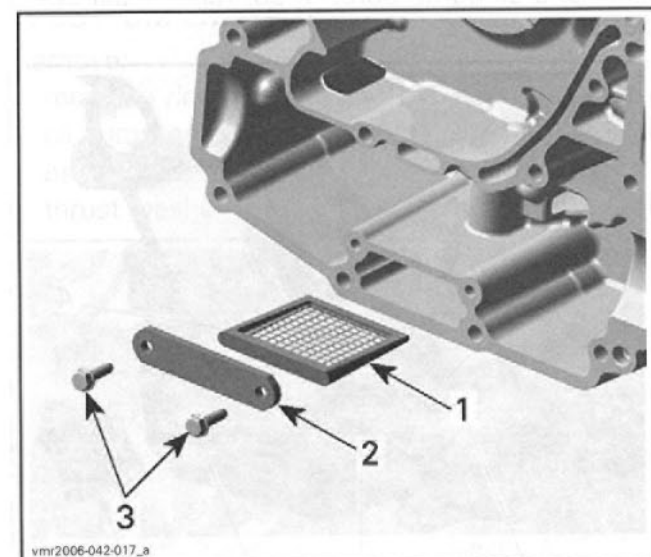

vmr2006-042-017_a

1. Engine oil strainer
2. Retaining plate
3. Screws

Removal

Refer to *BOTTOM END* section.

Cleaning and Inspection

Clean engine oil strainer with a part cleaner then use an air gun to dry it.

WARNING

Always wear eye protector. Chemicals can cause a rash break out and injure your eyes.

Check engine oil strainer for cracks or other damage. Replace if damaged.

Installation

Refer to *BOTTOM END* section.

REED VALVE

The engine is equipped with a reed valve no. 8 which prevents accumulation of larger oil quantities in the crankcase. The reed valve is fitted into the crankcase.

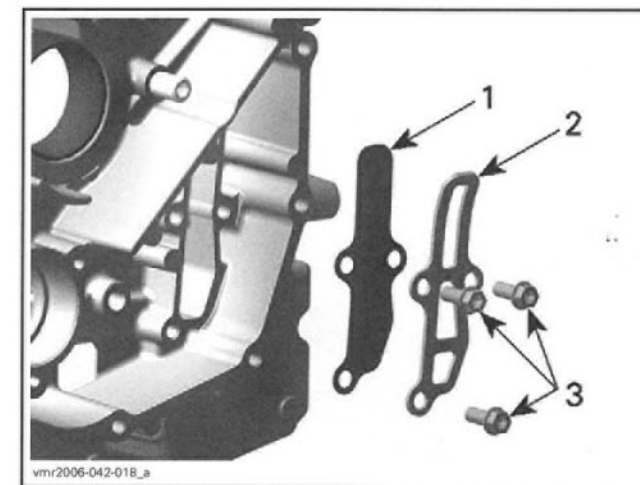

vmr2006-042-018_a

1. Reed valve
2. Stopper
3. Screws

Removal

Refer to *BOTTOM END*.

Inspection

Check reed valve for cracks or other damage.

NOTE: Replace reed valve if damaged.

Installation

Refer to *BOTTOM END*.

MAGNETO SYSTEM

SERVICE TOOLS

Description	Part Number	Page
crankshaft locking bolt.....	529 035 617	23
crankshaft protector	529 036 034	23
magneto puller.....	529 035 748	23

SERVICE PRODUCTS

Description	Part Number	Page
Bombardier gasket remover.....	413 708 500	21
Dreibond sealing compound.....	420 297 906	21

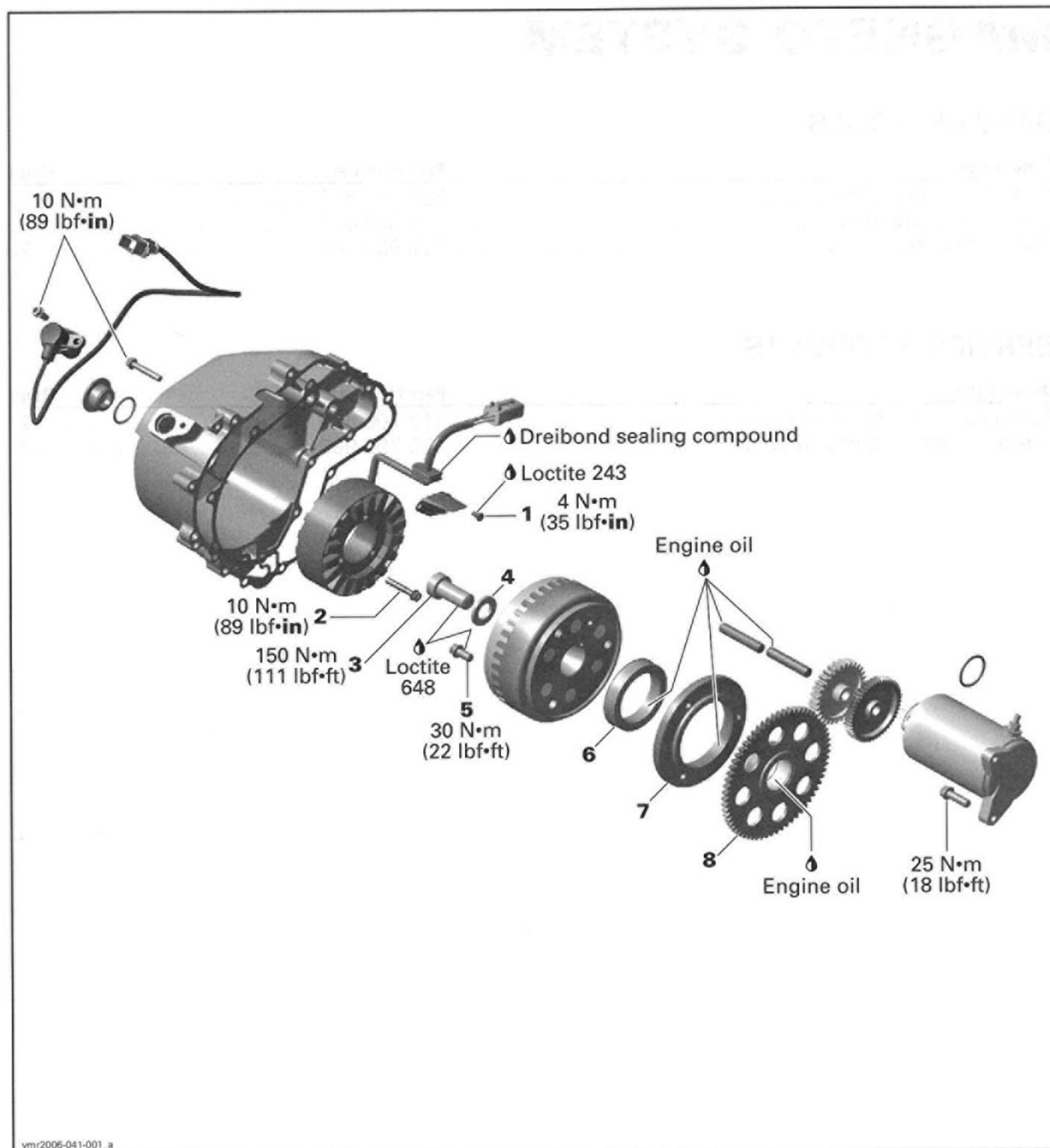

GENERAL

Always perform the electric tests before removing or installing whatever component.

During assembly/installation, use the torque values and service products as in the exploded views.

Clean threads before applying a threadlocker. Refer to *SELF-LOCKING FASTENERS* and *LOCTITE APPLICATION* at the beginning of this manual for complete procedure.

WARNING

Torque wrench tightening specifications must strictly be adhered to. Locking devices (e.g.: locking tabs, elastic stop nuts, self-locking fasteners, cotter pin, etc.) must be installed or replaced with new ones where specified. If the efficiency of a locking device is impaired, it must be renewed.

PROCEDURES

MAGNETO COVER

Removal

Lock crankshaft at TDC (refer to *CYLINDER AND HEAD*).

Drain engine oil (refer to appropriate *VEHICLE SHOP MANUAL*).

Disconnect CPS (Crankshaft Position Sensor) connector and cut tie rap.

Remove magneto cover retaining screws.

Pull magneto cover.

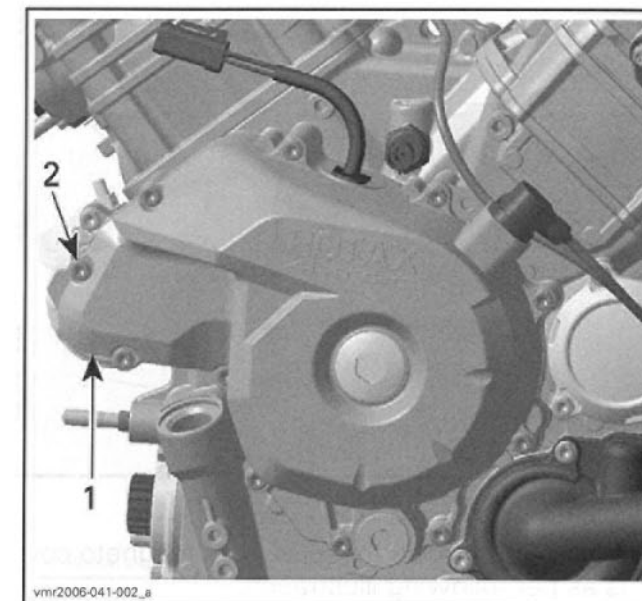

1. Magneto cover
2. Retaining screws

Inspection

Check magneto cover for cracks or other damage. Replace if necessary.

Installation

NOTE: Clean all metal component in a non-ferrous metal cleaner. Use Bombardier gasket remover (P/N 413 708 500), or suitable equivalent.

WARNING

Wear safety glasses and work in a well ventilated area when working with strong chemical products. Also wear suitable non-absorbent gloves to protect your hands.

For installation, reverse the removal procedure. However, pay attention to the following.

NOTE: At installation replace magneto cover gasket.

Apply Dreibond sealing compound (P/N 420 297 906) on stator cable grommet as shown in next illustration.

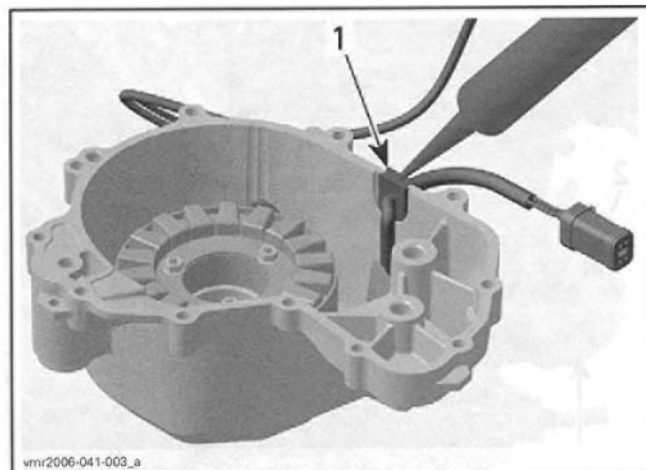

1. Apply Dreibond sealing compound

Tightening sequence for screws on magneto cover is as per following illustration.

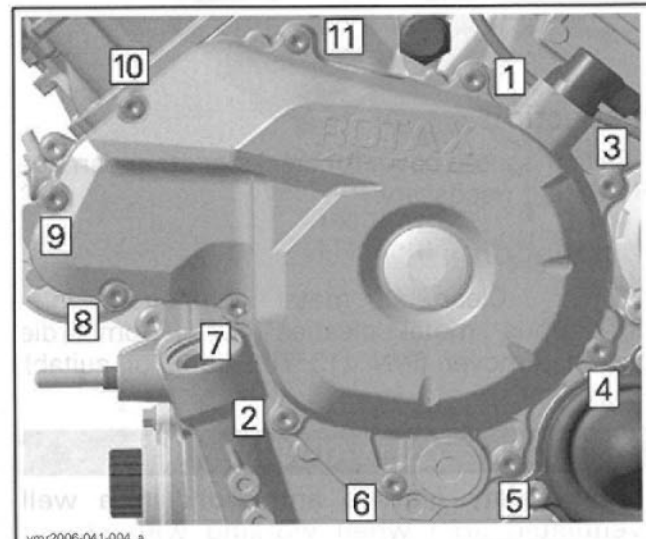

TIGHTENING SEQUENCE

STATOR

Removal

- Remove:
- magneto cover (refer to *MAGNETO COVER* above)
 - screws no. 1 and no. 2
 - stator.

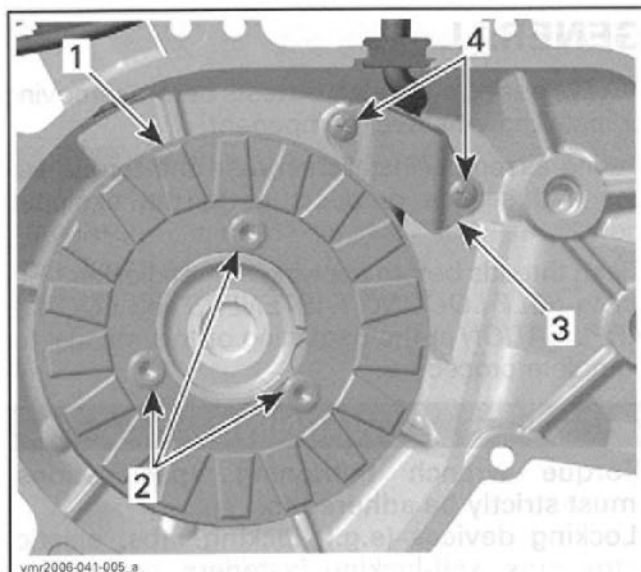

1. Stator
2. Stator retaining screws
3. Holding strip
4. Holding strip screws

Inspection

Check stator condition. If damaged replace it. Check if stator wires are brittle, hard or otherwise damaged.

For electrical inspection, refer to *CHARGING SYSTEM* in the appropriate *VEHICLE SHOP MANUAL*.

Installation

For installation, reverse the removal procedure. However, pay attention to the following.

CAUTION: When installing the stator take care that the cable is in place (guide for the wire).

NOTE: There is only one position for the stator (notch in the magneto housing cover).

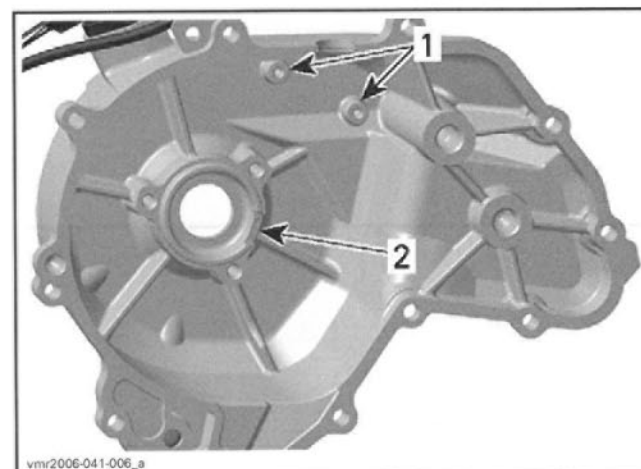

1. Threads for cable holding strip
2. Notch for stator

ROTOR

Removal

Lock crankshaft with crankshaft locking bolt (P/N 529 035 617) (refer to *CYLINDER AND HEAD*).

Remove:

- magneto cover
- retaining screw no. 3
- washer no. 4.

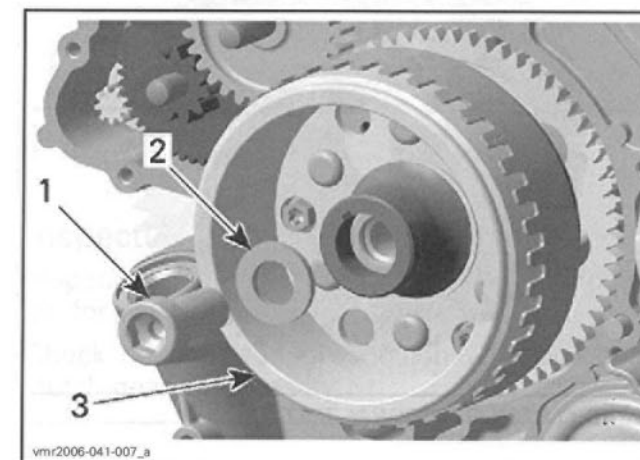

1. Screw M16
2. Washer
3. Rotor

Install magneto puller (P/N 529 035 748) and crankshaft protector (P/N 529 036 034) then remove rotor.

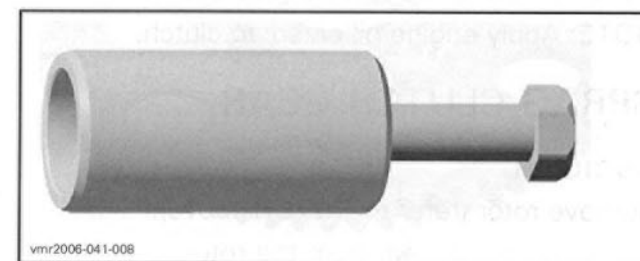

MAGNETO PULLER

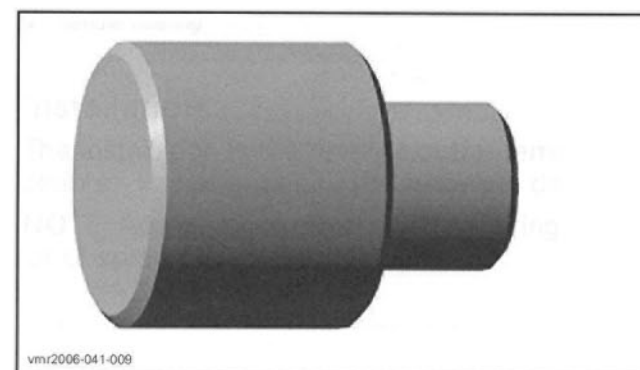

CRANKSHAFT PROTECTOR

NOTE: Use grease to place protector on crankshaft end prior to screw on the magneto puller.

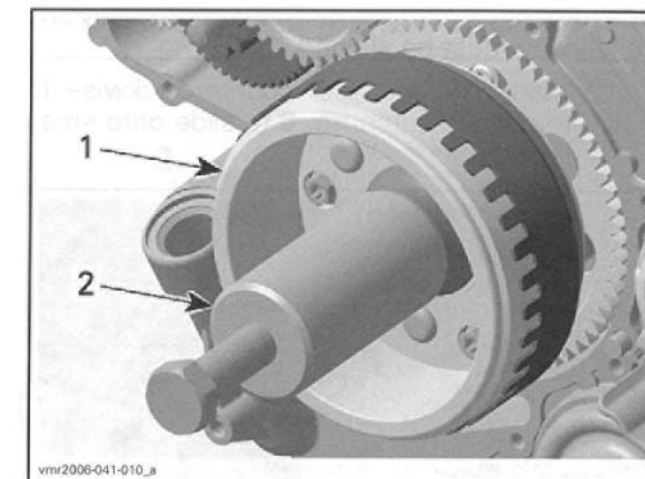

1. Rotor
2. Magneto puller

Inspection

Check inner side of rotor for scratches or other damage.

Check if trigger wheel teeth are bent or otherwise damaged.



1. Rotor with trigger wheel

Check woodruff key and keyway on the crankshaft for wear or damages.

Replace parts as necessary.

Installation

For installation, reverse the removal procedure. However, pay attention to the following.

CAUTION: Taper on crankshaft and rotor must be free of grease.

Oil sprag clutch no. 6 in sprag clutch housing no. 7.

Slide rotor onto crankshaft. The woodruff key and the keyway must be aligned.

Rotate starter double gear counterclockwise to enable the sprag clutch no. 6 to slide onto sprag clutch gear no. 8.

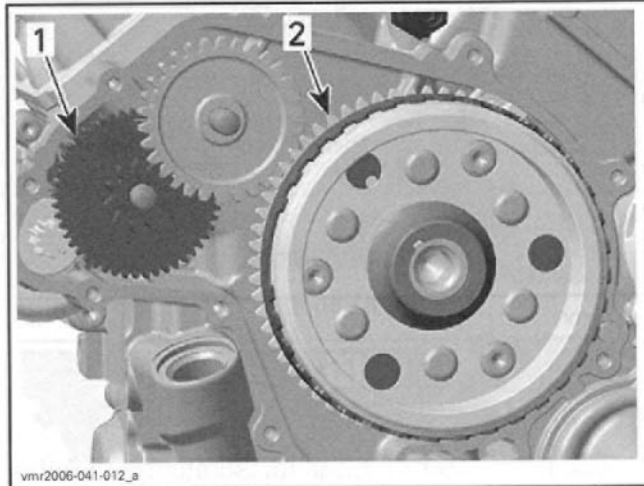

1. Starter double gear
2. Sprag clutch gear

SPRAG CLUTCH

Removal

- Remove:
- magneto cover (refer to *MAGNETO COVER* above)
 - rotor (refer to *ROTOR* above)
 - retaining screws no. 5

NOTE: Loosen screws no. 5 prior to pull the rotor. This will ease removal of screws.

- sprag clutch housing no. 7.

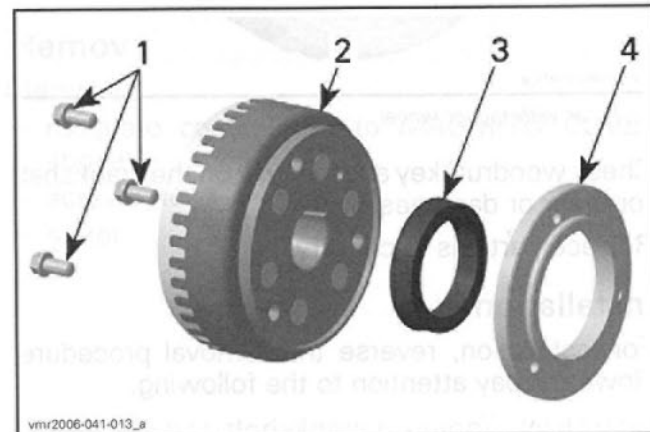

1. Screws
2. Rotor
3. Sprag clutch
4. Sprag clutch housing

Inspection

Inspect sprag clutch and sprag clutch housing for wear and damage.

Perform a functional test of the sprag clutch. To do so, rotate sprag clutch gear in sprag clutch.

NOTE: Sprag clutch must lock in counterclockwise direction.

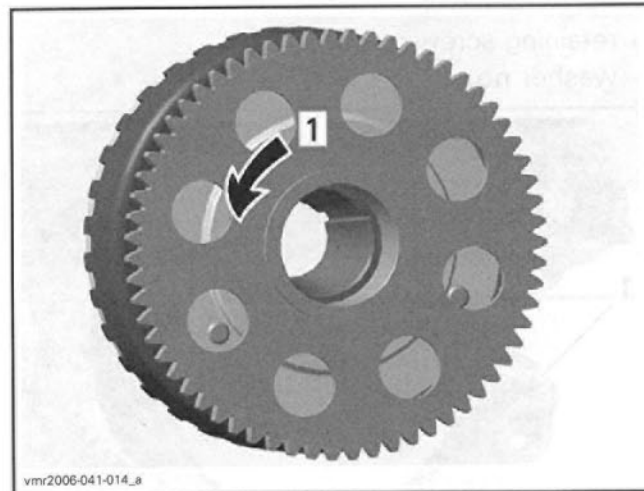

SPRAG CLUTCH FUNCTIONAL TEST
1. Lock

NOTE: Sprag clutch, housing and gear must be replaced at the same time, if damaged.

Installation

For installation, reverse the removal procedure. Pay attention to the following details.

NOTE: Apply engine oil on sprag clutch.

SPRAG CLUTCH GEAR

Removal

Remove rotor (refer to *ROTOR* above).

Pull sprag clutch gear from the rotor.

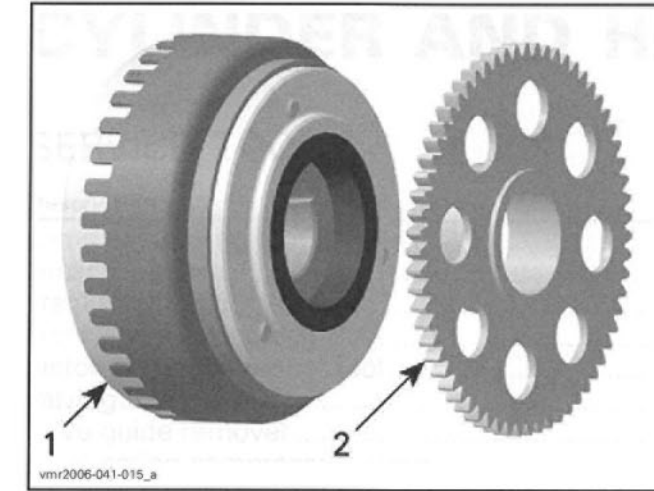

1. Rotor
2. Sprag clutch gear

Inspection

Inspect gear, especially teeth and sprag clutch collar, for wear and other damage.

Check needle bearing condition. Replace sprag clutch gear if necessary.

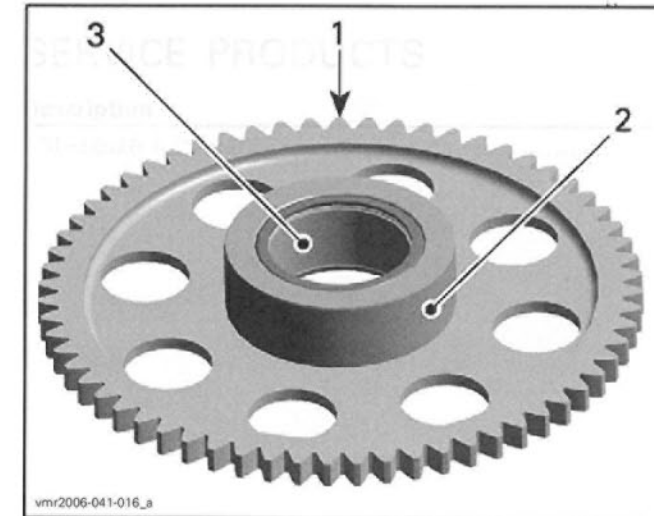

INSPECT
1. Teeth
2. Collar
3. Needle bearing

Installation

The installation is the reverse of the removal procedure. Pay attention to the following details.

NOTE: Apply engine oil on needle bearing and collar of sprag clutch gear.

STARTER DRIVE GEARS

The starter drive gears are located on the engine MAG side behind the magneto cover.

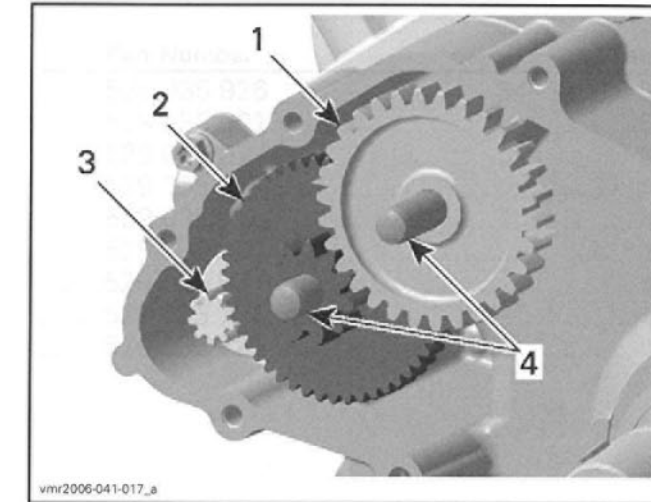

1. Intermediate gear
2. Starter double gear
3. Starter gear
4. Location pins

Removal

Remove:

- magneto cover (refer to *MAGNETO COVER* above)
- location pins
- starter double gear
- intermediate gear.

Inspection

Inspect starter drive gears and location pins for wear and damage.

Replace parts as necessary.

Installation

The installation is the reverse of the removal procedure.

CYLINDER AND HEAD

SERVICE TOOLS

Description	Part Number	Page
camshaft locking tool.....	529 035 926	34-35, 37-38
circlip installer	529 035 921	53
crankshaft locking bolt.....	529 035 617	37
crankshaft locking bolt.....	529 035 926	37, 48
piston ring compressor tool.....	529 035 919	49
valve guide installer	529 035 853	47
valve guide remover	529 035 924	47
valve spring compressor clamp	529 035 724	44
valve spring compressor cup.....	529 035 725	44

SERVICE TOOLS – OTHER SUPPLIER

Description	Part Number	Page
Snap-ON pliers.....	YA 8230	45

SERVICE PRODUCTS

Description	Part Number	Page
anti-seize lubricant	293 800 070	48

Section 01 V-810 ENGINE
Subsection 05 (CYLINDER AND HEAD)

NOTE: For cylinder head, cylinder and piston removal, it is not necessary to remove engine from vehicle.

FRONT CYLINDER HEAD (NO. 1)

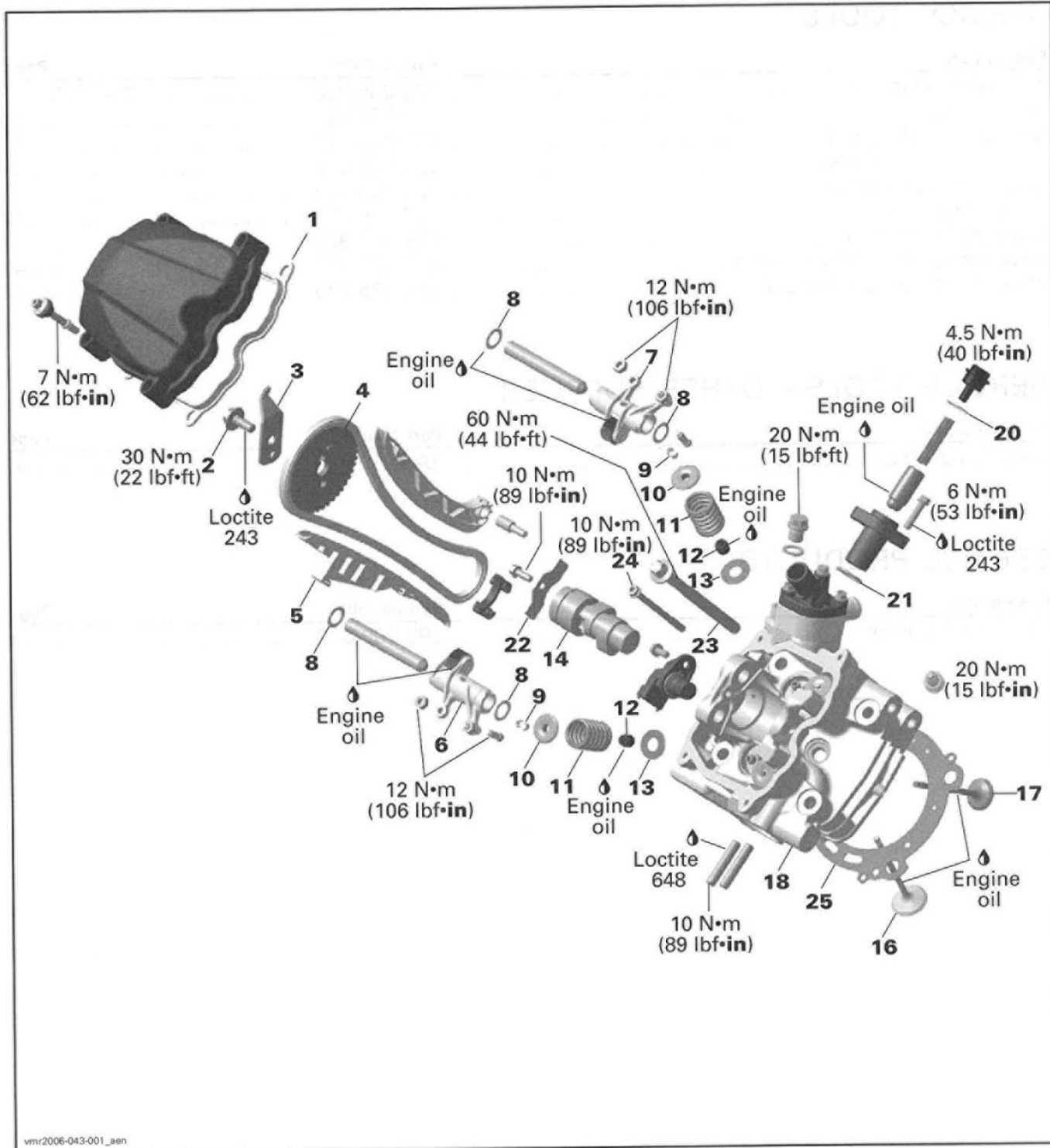

Section 01 V-810 ENGINE
Subsection 05 (CYLINDER AND HEAD)

REAR CYLINDER HEAD (NO. 2)

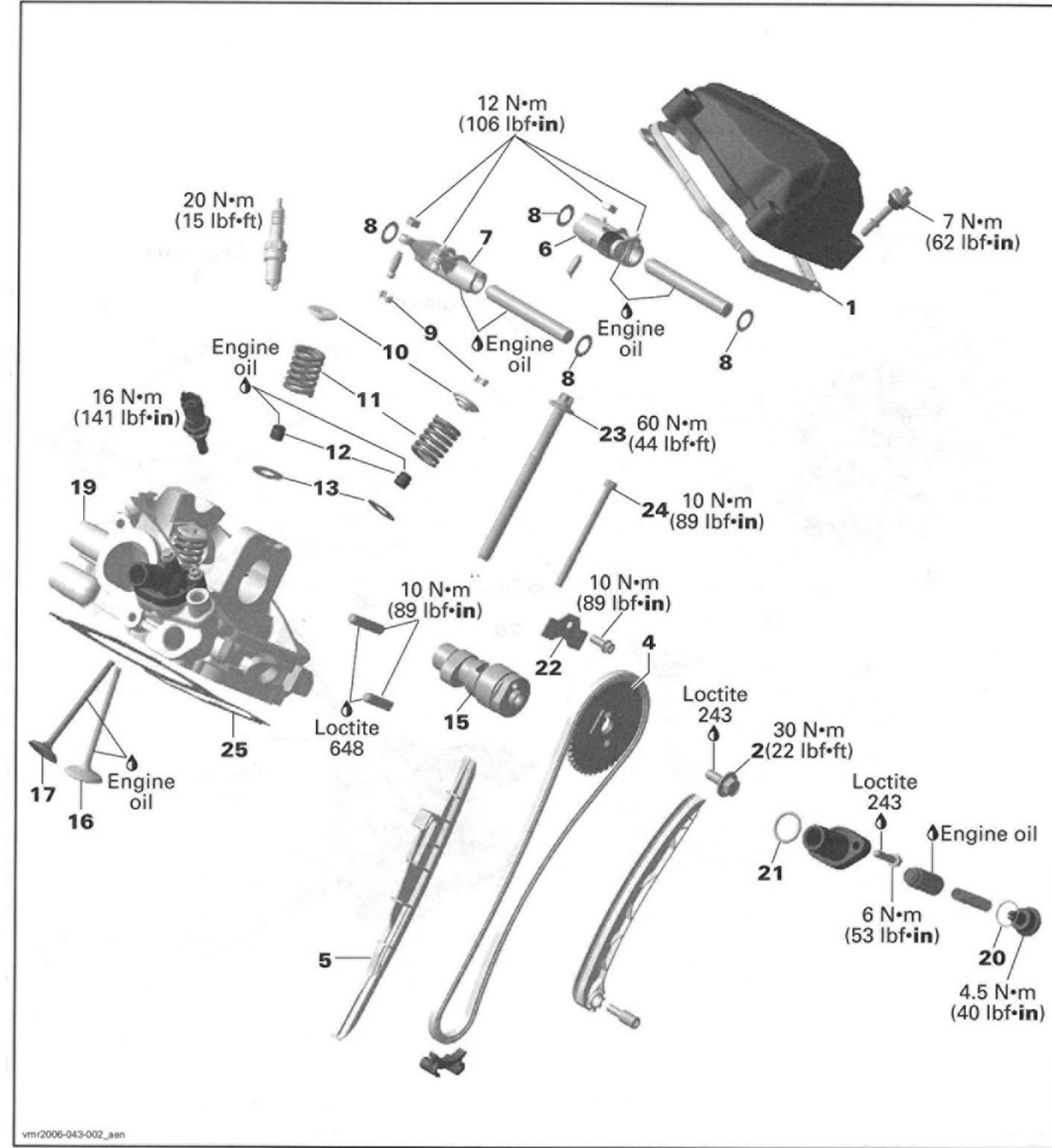

CYLINDERS AND PISTONS

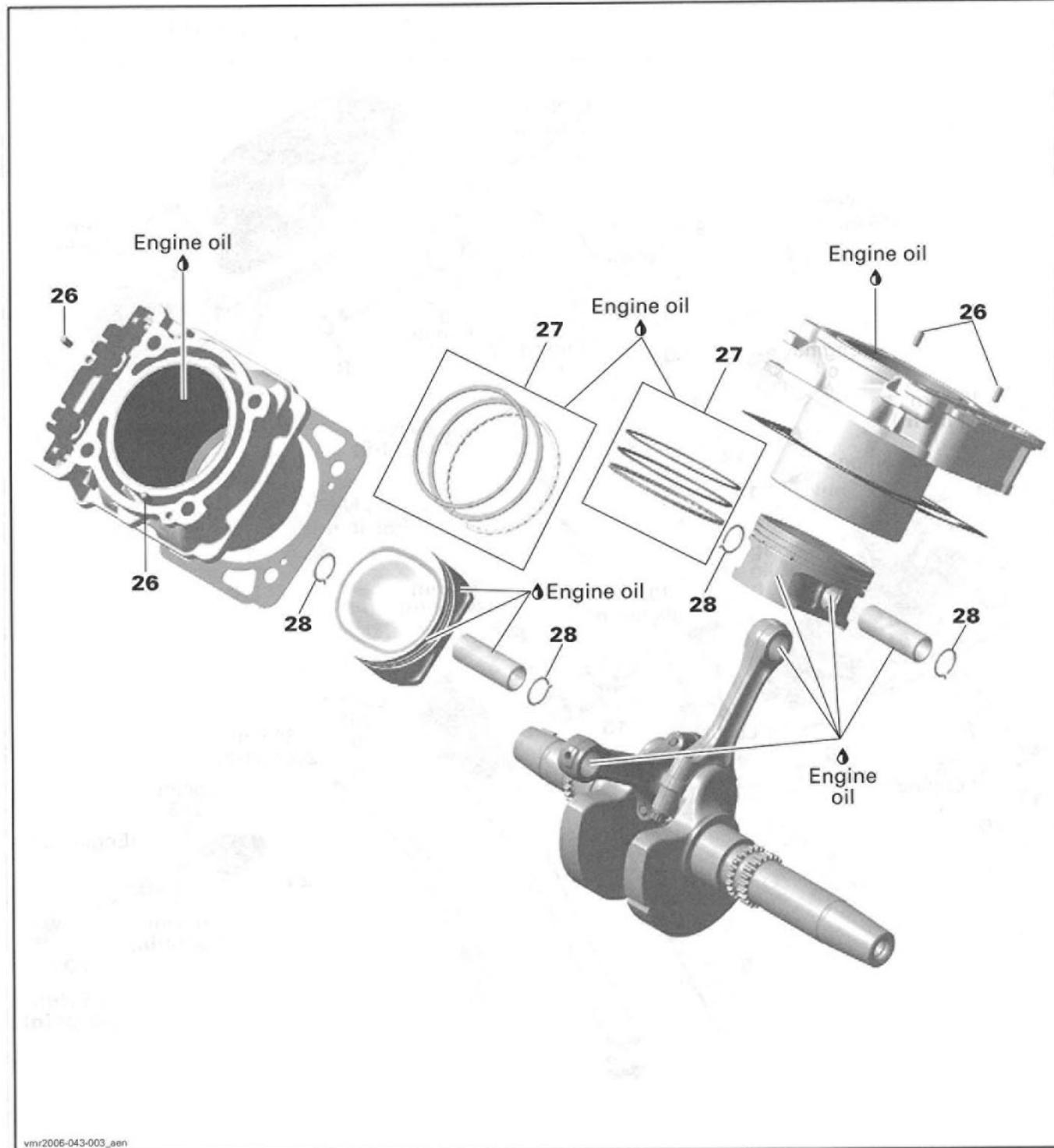

vnr2006-043-003_aen

GENERAL

NOTE: Components which are identical for both cylinders/cylinder heads are identified in the two exploded views by the same number. Components which are different or which are, for instance, present on one of the cylinders/cylinder heads but not on the other, have different numbers. The information given below always relates as a general rule.

Special reference is made in the text to work instructions which are not the same for front cylinder no. 1, and rear cylinder no. 2.

NOTE: When diagnosing an engine problem, always perform a cylinder leak test. This will help pin-point a problem. Refer to the instructions included with your leak tester and *LEAK TEST* section for procedures.

Always place the vehicle on level surface.

NOTE: For a better understanding, the many illustrations are taken with engine out of vehicle. To perform the following instructions, it is not necessary to remove engine from vehicle.

Always disconnect BLACK (-) cable from the battery, then RED (+) cable before working on the engine.

Even if the removal of many parts is not necessary to reach another part, it is recommended to remove these parts in order to check them.

During assembly/installation, use the torque values and service products as in the exploded views.

Clean threads before applying a threadlocker. Refer to *SELF-LOCKING FASTENERS* and *LOCTITE APPLICATION* at the beginning of this manual for complete procedure.

⚠ WARNING

Torque wrench tightening specifications must strictly be adhered to. Locking devices (e.g.: locking tabs, elastic stop nuts, self-locking fasteners, cotter pin, etc.) must be installed or replaced with new ones where specified. If the efficiency of a locking device is impaired, it must be renewed.

When disassembling parts that are duplicated in the engine, (e.g.: valves), it is a strongly recommended to note their position (PTO/MAG side, front/rear cylinder) and to keep them as a "group". If you find a defective component, it would be much easier to find the cause of the failure among its group of parts (e.g.: you found a worn valve guide. A bent spring could be the cause and it will be easy to know which one among the springs is the cause to replace it if you grouped them at disassembly). Also, since used parts have matched together during the engine operation, they will keep their matched fit when you reassemble them together within their "group".

PROCEDURES

SPARK PLUG

Removal

Unplug and remove spark plug cable.
Clean spark plug area before disassembly.
Unscrew spark plug.

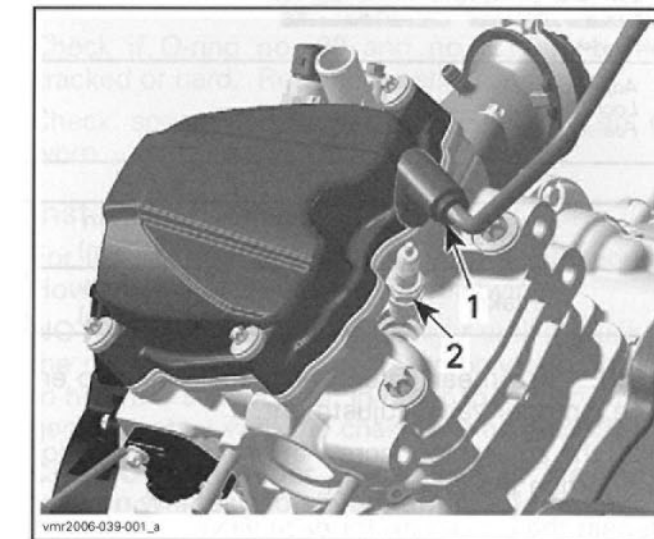

1. Spark plug cable
2. Spark plug

Inspection

Check spark plug condition and gap (refer to appropriate *VEHICLE SHOP MANUAL*).

Installation

For installation, reverse the removal procedure. Pay attention to the following details.

Screw spark plug. Reinstall the spark plug cable.

VALVE ADJUSTMENT

Remove valve covers. Refer to procedure elsewhere in this section.

Turn crankshaft to ignition TDC, see *CRANKSHAFT LOCKING PROCEDURE* and *CAMSHAFT TIMING PROCEDURE* below.

Hold adjustment screw and loosen locking nut. Using feeler gauge, check the valve clearance.

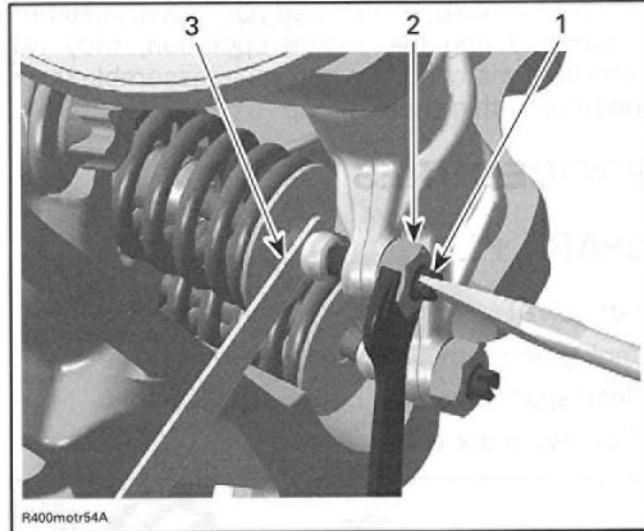

1. Adjustment screw
2. Locking nut
3. Feeler gauge

VALVE CLEARANCE	
Exhaust	0.11 to 0.19 mm (.0043 to .0075 in)
Intake	0.06 to 0.14 mm (.0024 to .0055 in)

NOTE: Use mean value of exhaust/intake to ensure a proper valve adjustment.

Hold the adjustment screw at the proper position and torque the locking nut.

Repeat the procedure for each valve.

Before installing valve covers, recheck all valve adjustments.

VALVE COVER

Removal

- Remove:
- distance screws of valve cover

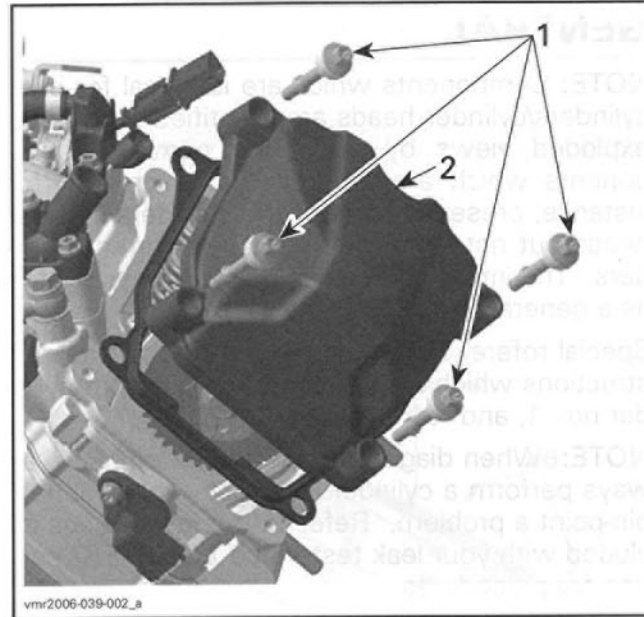

1. Distance screws
2. Valve cover

- valve cover and profile gasket no. 1.

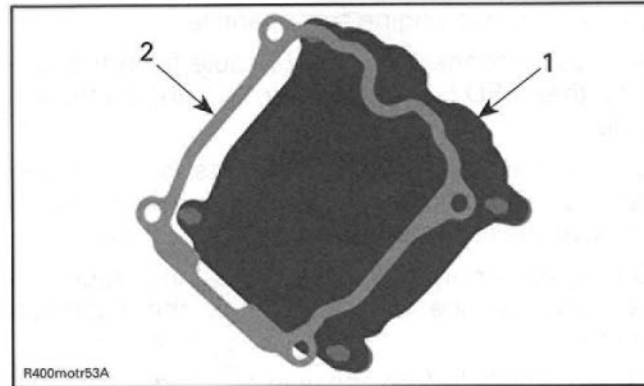

1. Valve cover
2. Profile gasket

Repeat the procedure for the other valve cover if required.

Inspection

Check the profile gasket on the valve cover if it is brittle, cracked or hard. If so, replace the profile gasket.

Installation

For installation, reverse the removal procedure. Torque the valve cover distance screws in a criss-cross sequence.

CHAIN TENSIONER

Removal

⚠ WARNING

Chain tensioner is spring loaded. Never perform this operation immediately after the engine has been run because the exhaust system can be very hot. Wait until exhaust system is warm or cold.

Remove:

- chain tensioner plug
- O-ring no. 20
- spring
- chain tensioner plunger

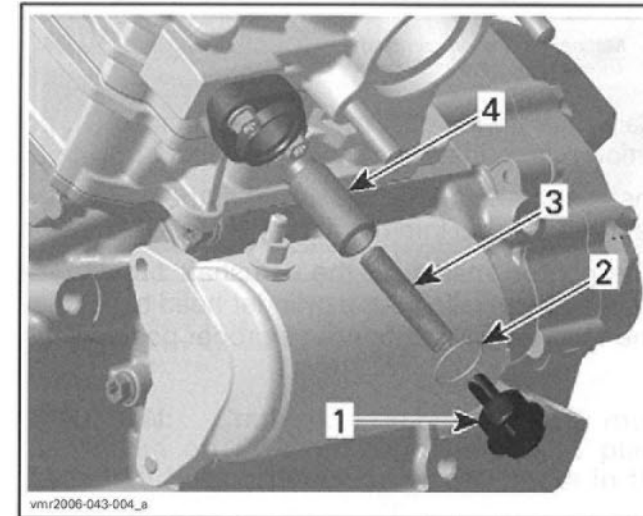

1. Chain tensioner plug
2. O-ring
3. Spring
4. Chain tensioner plunger

- screws retaining chain tensioner housing
- chain tensioner housing with O-ring no. 21.

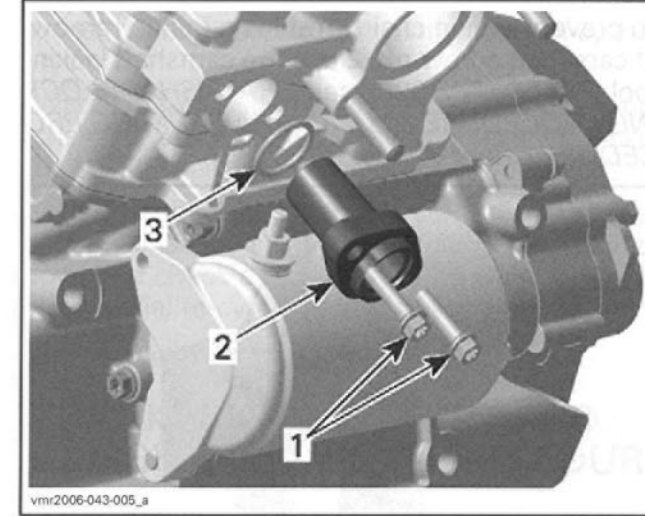

1. Chain tensioner screws
2. Chain tensioner housing
3. O-ring

Inspection

Check the housing for cracks or other damages. Replace if necessary.

Check chain tensioner plunger for free movement and/or scoring.

Check if O-ring no. 20 and no. 21 are brittle, cracked or hard. Replace if necessary.

Check spring condition. Replace if broken or worn.

Installation

For installation, reverse the removal procedure. However, pay attention to the following.

NOTE: Slightly screw the plunger until it touches the chain tensioner guide. Use only two fingers to hold the screwdriver, in order to recognize the gentle contact with the chain tensioner guide.

CAUTION: Improper adjustment of the chain tensioner will lead to severe engine damage.

Install a spring end in plunger groove and the other in the plug groove. Screw plug.

NOTE: Do not forget to place the O-ring no. 20 on chain tensioner plug.

CAMSHAFT TIMING GEAR

Removal

Remove:

- valve cover

Turn crankshaft to ignition TDC, see *CRANKSHAFT LOCKING PROCEDURE* and *CAMSHAFT TIMING PROCEDURE* below.

- chain tensioner

To prevent timing chain stretching during removal of camshaft screw no. 2 use the camshaft locking tool (P/N 529 035 926), see *CRANKSHAFT LOCKING PROCEDURE* and *CAMSHAFT TIMING PROCEDURE* below.

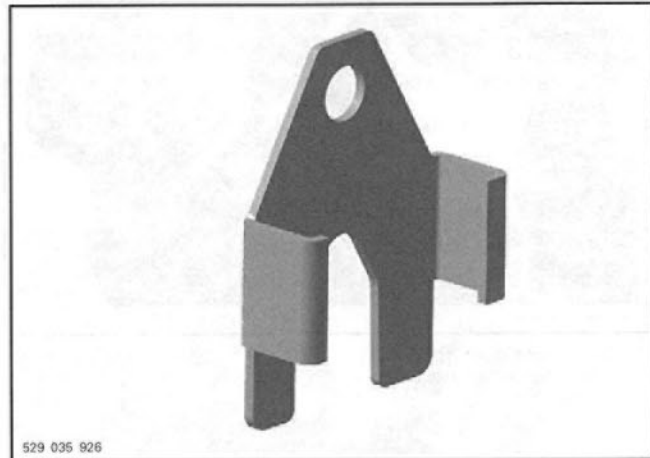

529 035 926

Clean mating surface and threads of camshaft prior to assemble camshaft timing gear.

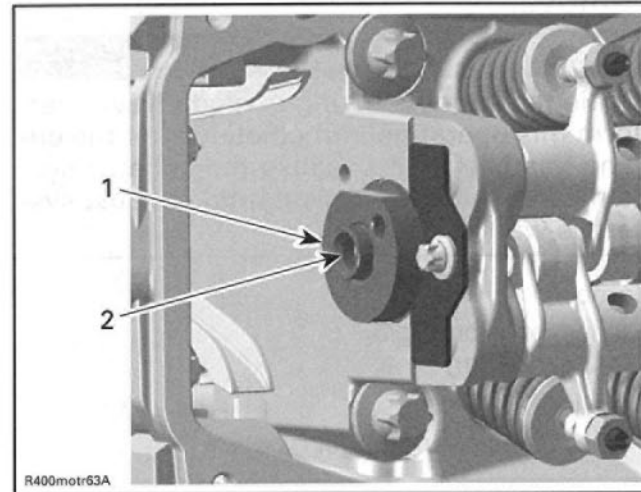

1. Mating surface on camshaft
2. Threads for camshaft screw

Camshaft timing gear must be at ignition TDC position before installing the timing chain.

Install camshaft timing gear so that the timing gear tabs are located into the flat zone of the camshaft.

The printed marks on the camshaft timing gear have to be parallel to the cylinder head base. See the following illustration for a proper positioning.

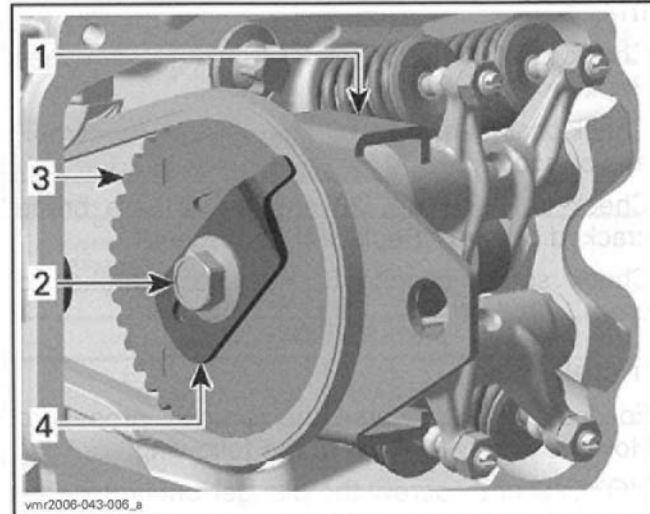

vmr2006-043-006_a

1. Camshaft locking tool
2. Camshaft screw
3. Camshaft timing gear
4. Trigger wheel (cylinder head 1, front only)

– camshaft timing gear.

NOTE: Secure timing chain with a retaining wire.

Inspection

Check camshaft timing gear for wear or deterioration.

If gear is worn or damaged, replace it as a set (camshaft timing gear and timing chain).

For crankshaft timing gear, refer to *BOTTOM END*, see *CRANKSHAFT*.

Installation

For installation, reverse the removal procedure. Pay attention to the following details.

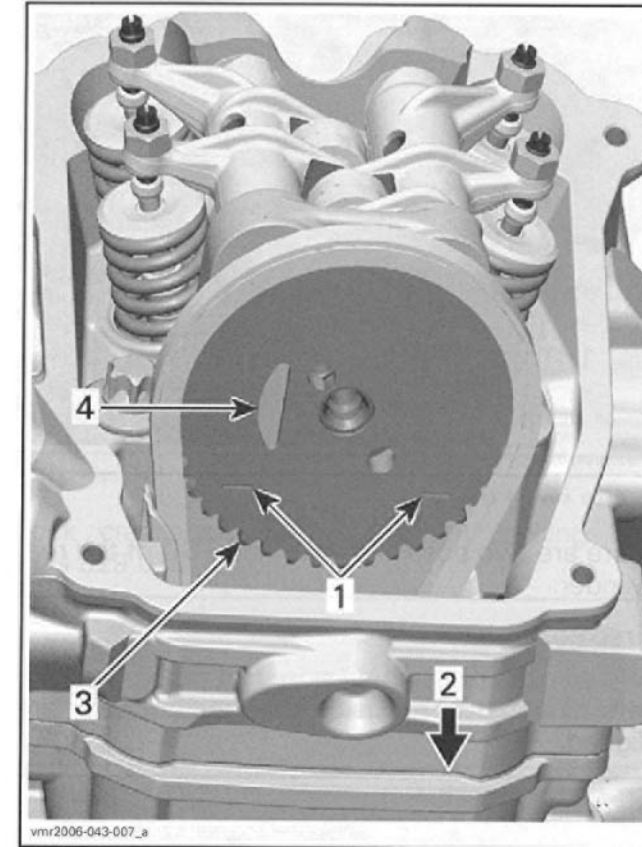

vmr2006-043-007_a

1. Printed marks on camshaft timing gear
2. Cylinder head base
3. Camshaft timing gear
4. Timing gear tab

CAUTION: Crankshaft and camshaft must be locked on ignition TDC position to place camshaft timing gear and timing chain in the proper position. Double-check position of timing gear with camshaft locking tool (P/N 529 035 926).

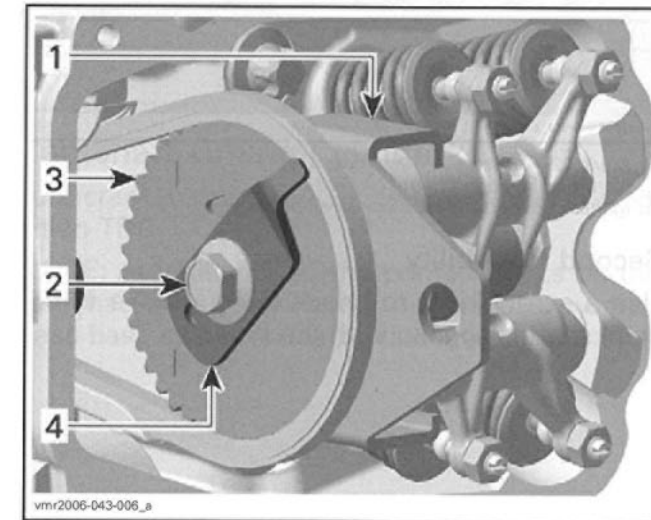

vmr2006-043-006_a

1. Camshaft locking tool
2. Camshaft screw
3. Camshaft timing gear
4. Trigger wheel (cylinder head 1 (front) only)

Install pick up gear no. 3 on timing gear of cylinder 1, front.

When the camshaft timing gear and the timing chain are installed, remove the crankshaft locking bolt as well as the camshaft locking tool.

NOTE: Before installing the camshaft screw adjust the chain tension (see *CHAIN TENSIONER* below) and check again if marks on the timing gear are parallel to cylinder head base.

Reinstall all other removed parts.

CRANKSHAFT LOCKING AND CAMSHAFT TIMING PROCEDURE

Removal

Remove:

- spark plug cable and spark plug of both cylinders
- valve covers of both cylinders
- plug screw and O-ring of ignition cover

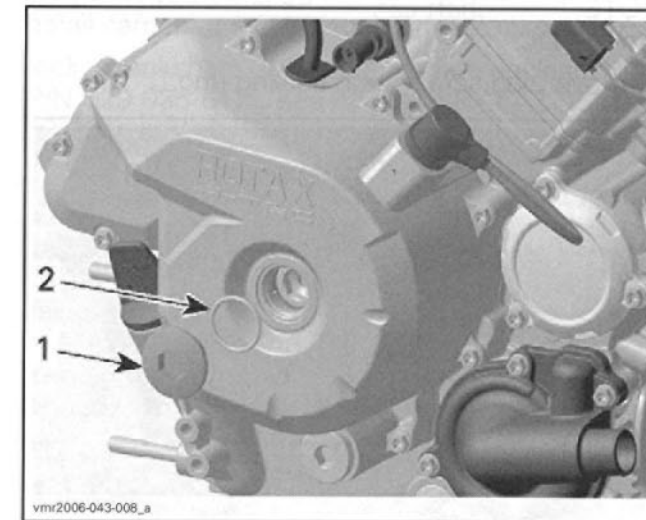

vmr2006-043-008_a

1. Plug screw
2. O-ring

– crank position trigger.

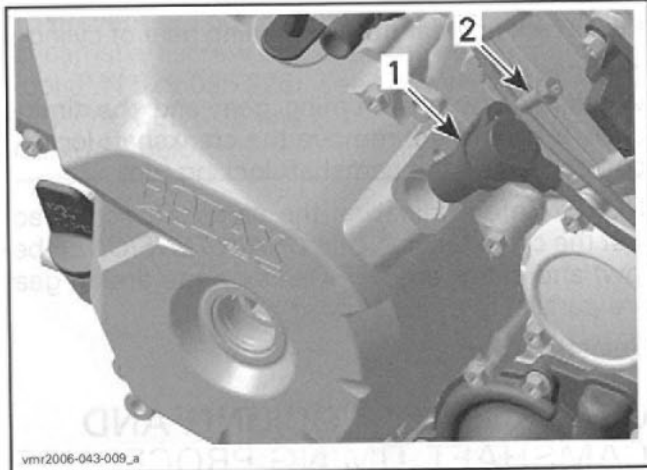

1. Crank position trigger
2. Screw

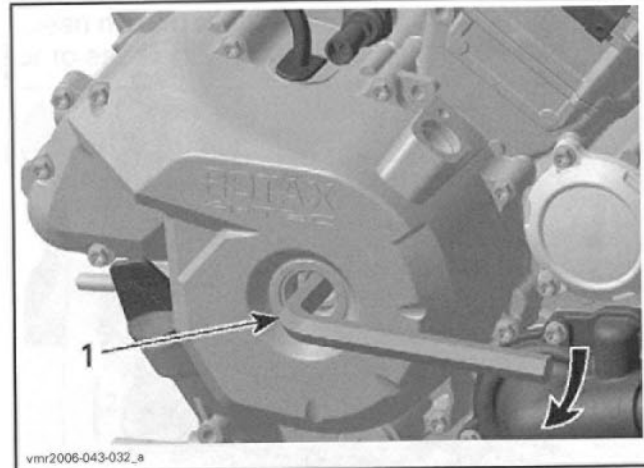

1. Allen key 14 mm

There are two possibilities to find TDC of the rear cylinder:

First Possibility

Turn crankshaft on MAG side until marks on magneto flywheel "2" and on the ignition cover are aligned.

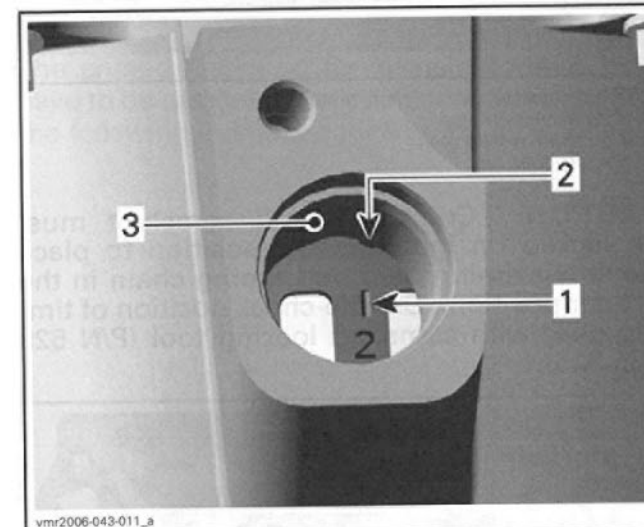

1. Mark "2" on magneto flywheel
2. Notch on ignition cover
3. Ignition cover/bore for crank position trigger

Second Possibility

Use a screwdriver to check if the groove in the crankshaft is aligned with the hole.

Crankshaft Locking Procedure

NOTE: When crankshaft is locked, the rear piston (cylinder 2, rear) is at TDC.

NOTE: Crankshaft can not be locked at cylinder 1 (front) TDC.

Remove plug screw with sealing ring.

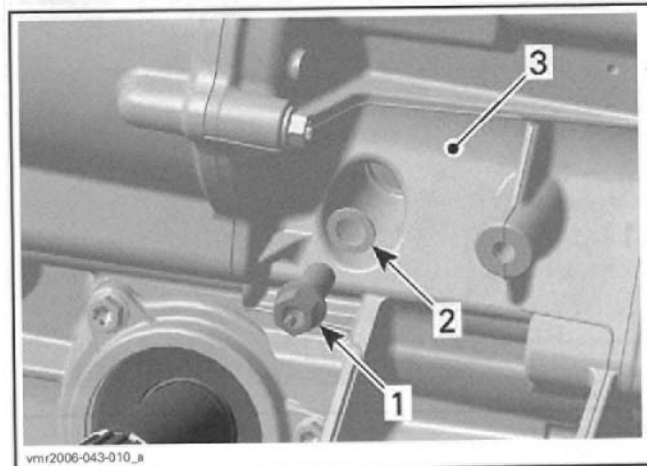

1. Plug screw
2. Sealing ring
3. Crankcase PTO side, front side

Use an Allen key 14 mm to turn crankshaft on MAG side until piston is at ignition TDC.

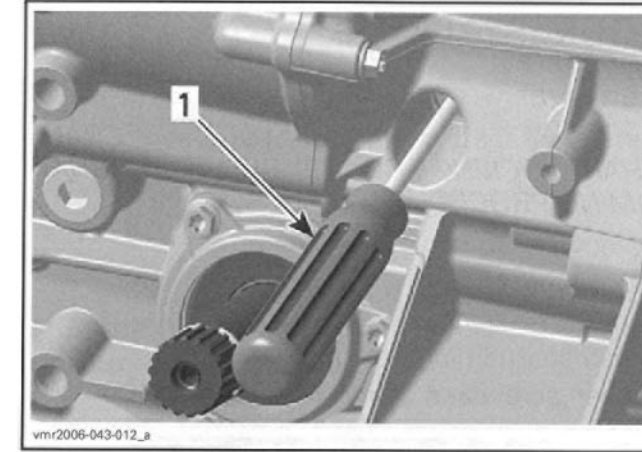

1. Screwdriver

Lock crankshaft with crankshaft locking bolt (P/N 529 035 926).

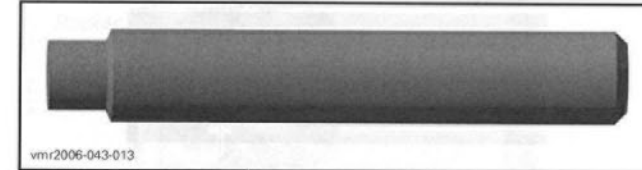

vmr2006-043-013

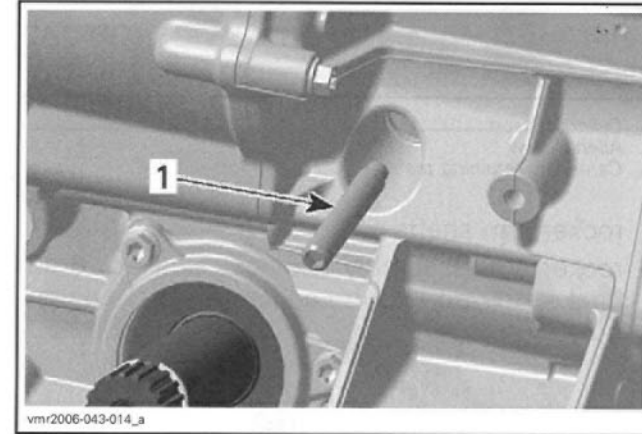

1. Crankshaft locking bolt

Camshaft Timing Cylinder 2, Rear

Turn crankshaft on MAG side until piston is at ignition TDC.

NOTE: At ignition TDC the printed marks on the camshaft timing gear have to be parallel to cylinder head base as per following illustration.

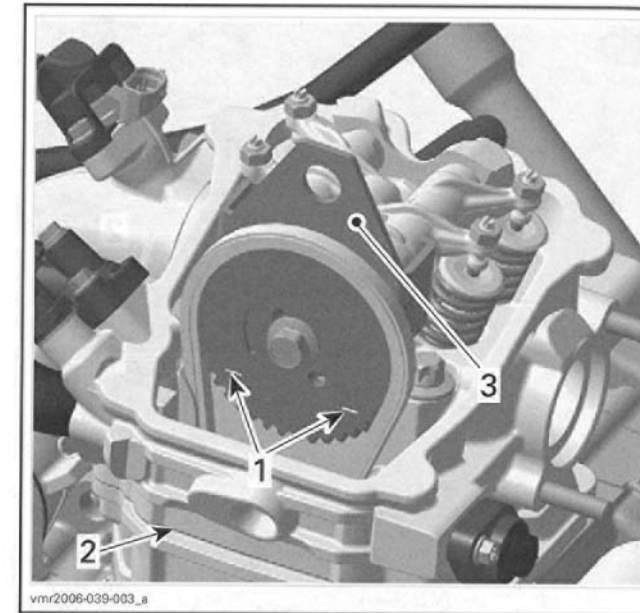

1. Printed marks on camshaft timing gear
2. Cylinder head base
3. Camshaft locking tool

Install camshaft locking tool (P/N 529 035 926).

Lock crankshaft with crankshaft locking bolt (P/N 529 035 617), see **CRANKSHAFT LOCKING PROCEDURE** above.

Camshaft Timing Cylinder 1, Front

Turn cylinder 2, rear to ignition TDC, see **CAMSHAFT TIMING CYLINDER 2** above.

Using an Allen key 14 mm and turn crankshaft on MAG side 280° counterclockwise, until marks on magneto flywheel "1" and ignition cover are aligned.

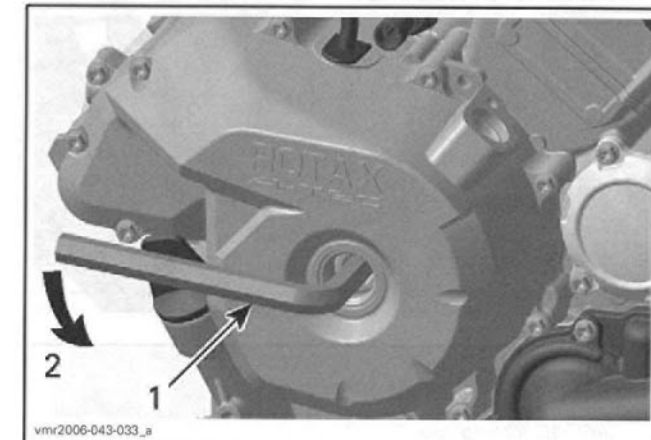

1. Allen key 14 mm
2. Turn crankshaft 280° counterclockwise

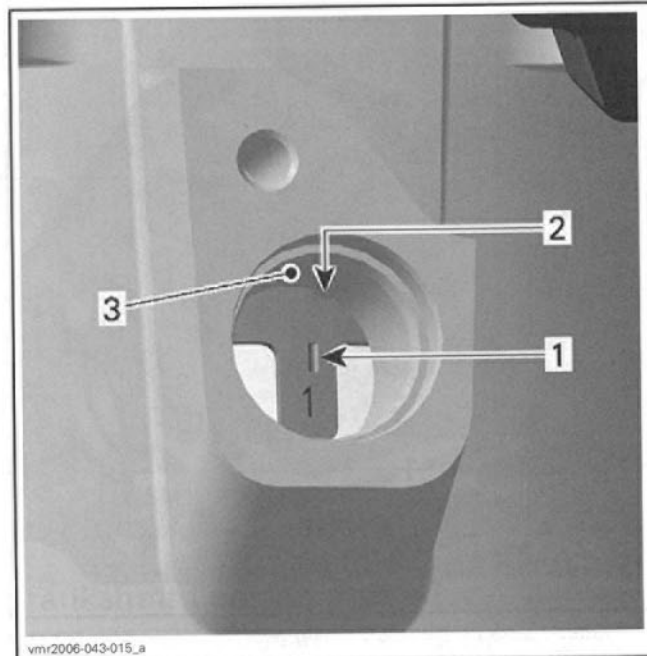

1. Mark "1" on magneto flywheel
2. Notch on ignition cover
3. Ignition cover/bore for crank position trigger

NOTE: At ignition TDC the printed marks on the camshaft timing gear have to be parallel to cylinder head base as per following illustration.

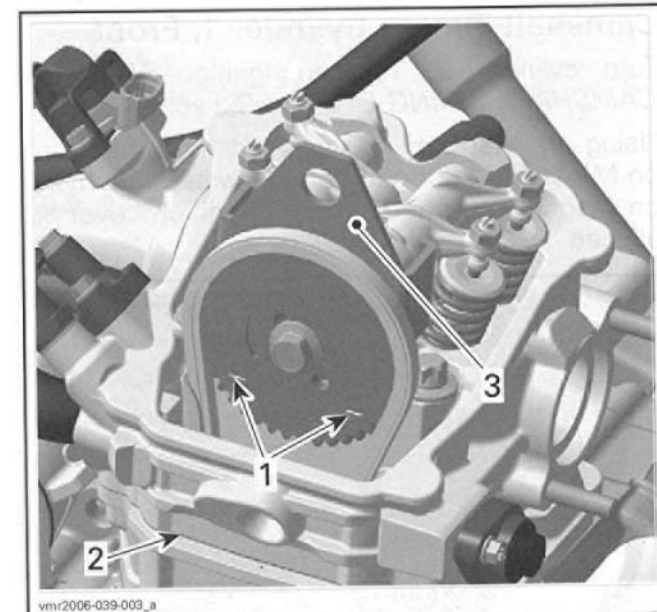

- TYPICAL**
1. Printed marks on camshaft timing gear
 2. Cylinder head base
 3. Camshaft locking tool

Install camshaft locking tool (P/N 529 035 926).

ROCKER ARM

Removal

Turn crankshaft to ignition TDC, see *CRANK-SHAFT LOCKING PROCEDURE* and *CAMSHAFT TIMING PROCEDURE* above.

Remove:

- valve cover
- chain tensioner
- camshaft timing gear no. 4
- allen screw and camshaft retaining plate

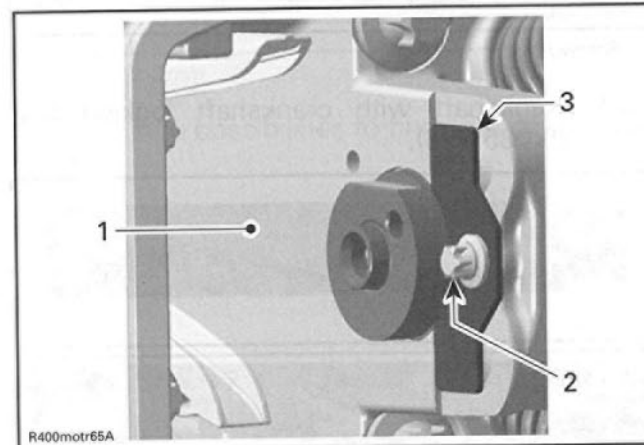

1. Cylinder head
2. Allen screw
3. Camshaft retaining plate

- rocker arm shafts
- rocker arm assembly (exhaust side no. 6 and intake side no. 7) with adjustment screws and nuts

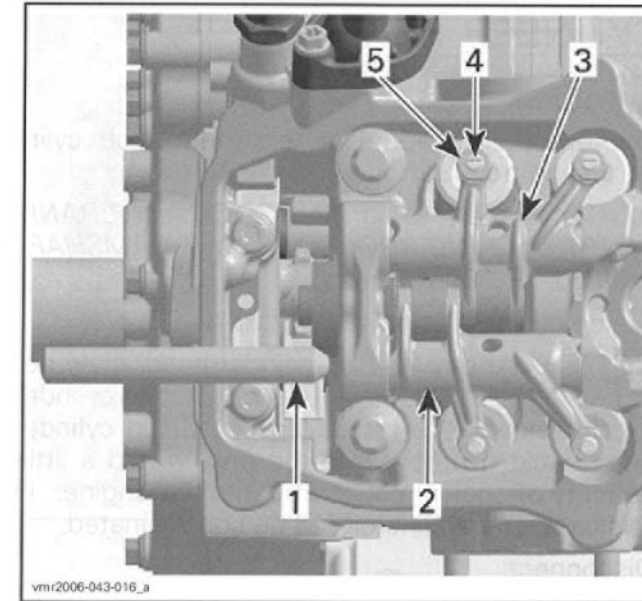

1. Rocker arm shaft
2. Rocker arm (exhaust side)
3. Rocker arm (intake side)
4. Adjustment screw
5. Locking nut

- thrust washers no. 8.

CAUTION: Pay attention not to lose thrust washers or drop them into the timing chain compartment.

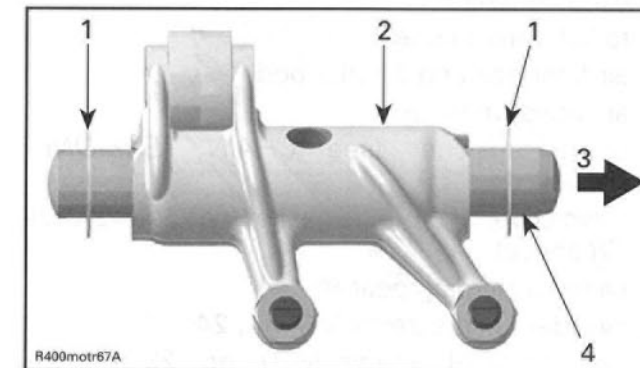

1. 2 thrust washers
2. Rocker arm (exhaust side)
3. Cylinder head — spark plug side
4. Big taper to spark plug side

Inspection

Rocker Arm

Inspect each rocker arm for cracks and scored friction surfaces. If so, replace rocker arm assembly. Check the rocker arm rollers for free movement, wear and excessive radial play. Replace rocker arm assembly if necessary.

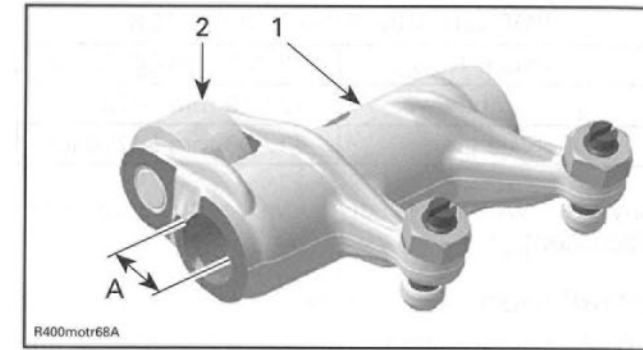

1. Rocker arm (exhaust side)
2. Roller
- A. Bore for rocker arm shaft

Measure rocker arm bore diameter. If diameter is out of specification, change the rocker arm assembly.

ROCKER ARM BORE DIAMETER

ROCKER ARM BORE DIAMETER	
Minimum New	12.036 mm (.4739 in)
Maximum New	12.050 mm (.4744 in)
Service limit	12.060 mm (.4748 in)

Check adjustment screws for free movement, cracks and/or excessive play.

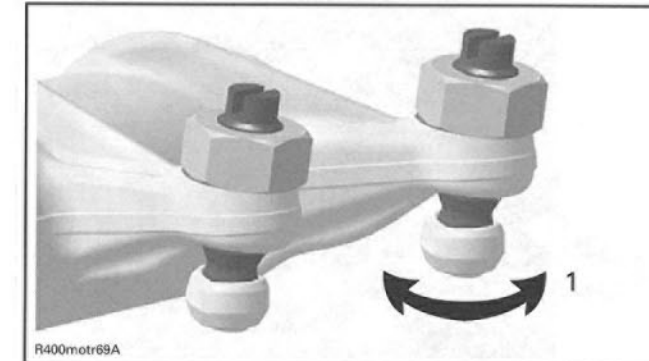

1. Free movement of adjustment screw top

Rocker Arm Shaft

Check for scored friction surfaces; if so, replace parts.

Measure rocker arm shaft diameter.

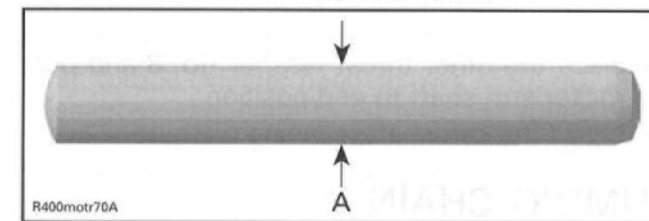

- A. Measure rocker arm shaft diameter here

ROCKER ARM SHAFT DIAMETER	
Minimum New	12.000 mm (.4724 in)
Maximum New	12.018 mm (.4731 in)
Service limit	11.990 mm (.4720 in)

Any area worn excessively will require parts replacement.

Installation

NOTE: Use the same procedure for exhaust and intake rocker arm.

Apply engine oil on rocker arm shaft.

Install the rocker arm shafts with the chamfered edge first and use following procedure:

- insert a rocker arm pin through rocker arm pin bore
- install a thrust washer **no. 8** then the proper rocker arm **no. 6** (exhaust side) or **no. 7** (intake side)
- push in rocker arm shaft until its chamfer reaches the end of rocker arm bore

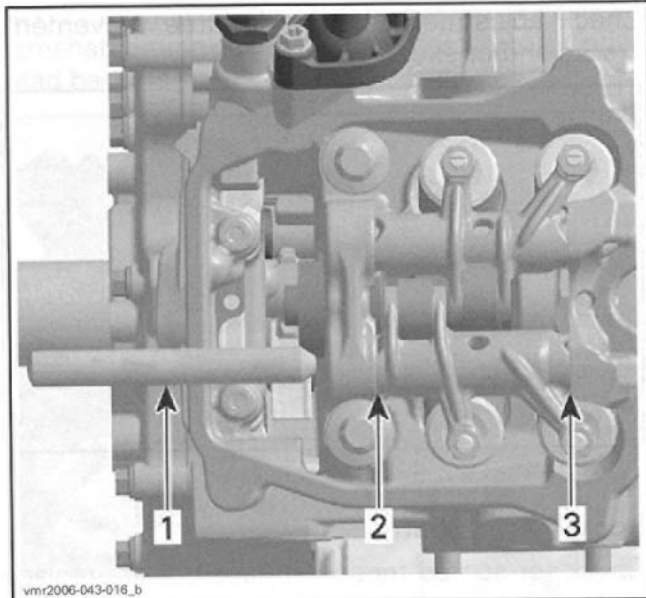

1. Rocker arm shaft
2. Thrust washer (timing chain side)
3. Thrust washer (spark plug side)

- place the other thrust washer **no. 8** and push rocker arm shaft to end position
- Install the camshaft retaining plate **no. 22**.

TIMING CHAIN

Refer to *BOTTOM END*, see *TIMING CHAIN*.

CYLINDER HEAD

Removal

The removal procedure is the same for both cylinder heads **no. 18** (front) and **no. 19** (rear).

Turn crankshaft to ignition TDC, see *CRANKSHAFT LOCKING PROCEDURE* and *CAMSHAFT TIMING PROCEDURE* above.

Drain coolant (refer to *COOLING SYSTEM*).

NOTE: Before removing cylinder head, blow out remaining coolant by air pressure. During cylinder head removal, the remaining coolant in cylinder head could overflow into the engine and a little quantity of coolant could drop into the engine. In this case, the engine oil will be contaminated.

Disconnect:

- spark plug wire
- temperature sensor connector, located at rear cylinder head
- camshaft sensor, located at front cylinder head.

Remove:

- both side panels and both inner fenders (refer to *BODY*)
- exhaust pipe spring
- exhaust pipe nuts
- radiator inlet hose
- air filter box and throttle body
- air intake manifold
- chain tensioner (see *CHAIN TENSIONER* above)
- valve cover and profile gasket (see *VALVE COVER* above)
- camshaft timing gear
- cylinder head screws M6, **no. 24**
- cylinder head screws M10, **no. 23** retaining cylinder head and cylinder to cylinder base.

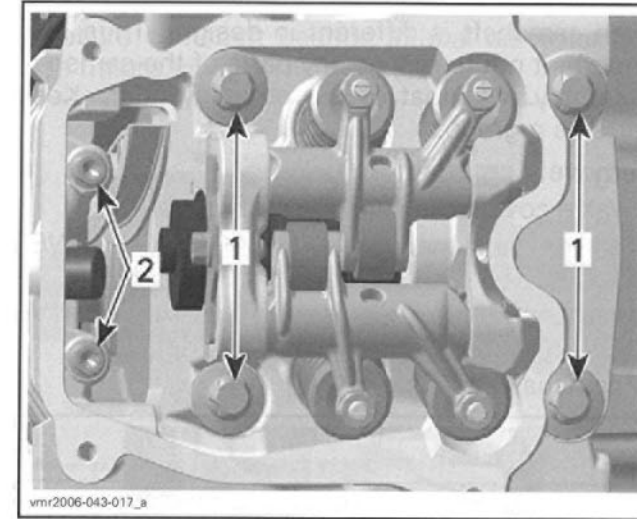

1. Cylinder head screws M10
2. Cylinder head screws M6

Pull up cylinder head.

Remove:

- chain guide **no. 5**
- cylinder head gasket **no. 25** and scrap it.

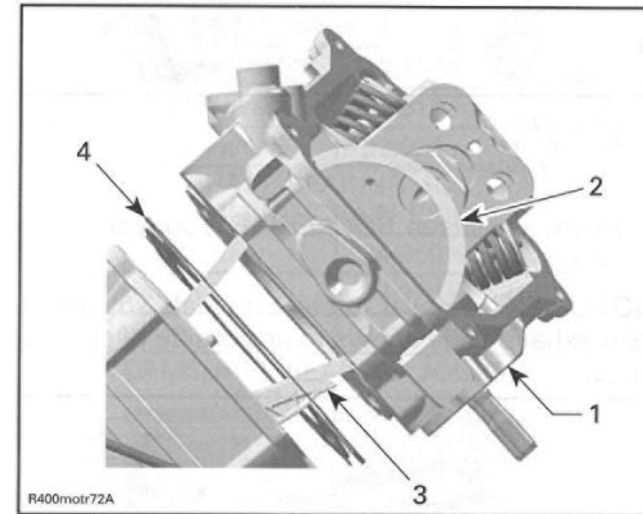

1. Cylinder head
2. Timing chain
3. Chain guide
4. Cylinder head gasket

Inspection

Inspect timing chain guide for wear, cracks or other damages. Replace if necessary.

Check for cracks between valve seats, if so, replace cylinder head.

Check mating surface between cylinder and cylinder head for contamination. If so, clean both surfaces.

Clean oil support through the cylinder head from contamination.

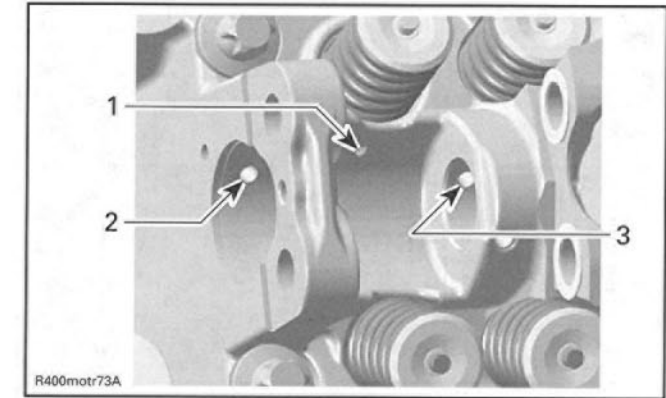

1. Oil port to lubricate camshaft lobes intake/exhaust
2. Oil supply to camshaft bearing journal timing chain side
3. Oil supply to camshaft bearing journal spark plug side

Installation

NOTE: The cylinder heads are not identical in design. Do not invert the cylinder heads at assembly.

For installation, reverse the removal procedure. Pay attention to the following details.

Ensure dowel pins **no. 26** are in place.

CAUTION: Chain guide has to be fixed between cylinder and cylinder head.

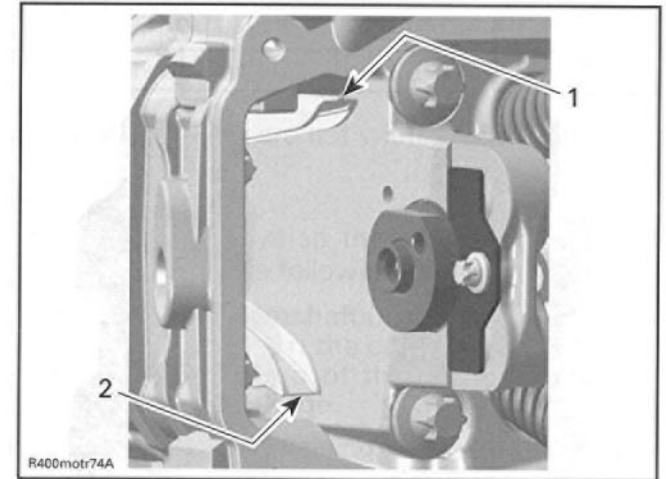

1. Chain guide (fixed between cylinder and cylinder head)
2. Chain tensioner guide (mounted in crankcase)

Install a new cylinder head gasket **no. 25**.

First, torque cylinder head screws M10, **no. 23** in criss-cross sequence to 20 N•m (15 lbf•ft) then finish tightening by applying the recommended torque indicated in the exploded view.

Install cylinder head screws M6, **no. 24**.

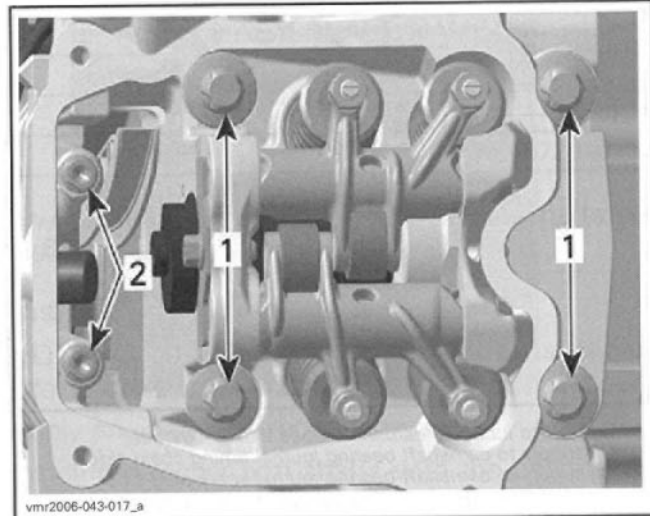

1. Cylinder head screws M10
2. Cylinder head screws M6

Check chain guide no. 5 for movement.
Remove crankshaft locking bolt and reinstall plug screw with sealing ring.

CAMSHAFT

NOTE: The engine is equipped with two different camshafts no. 14 and no. 15.

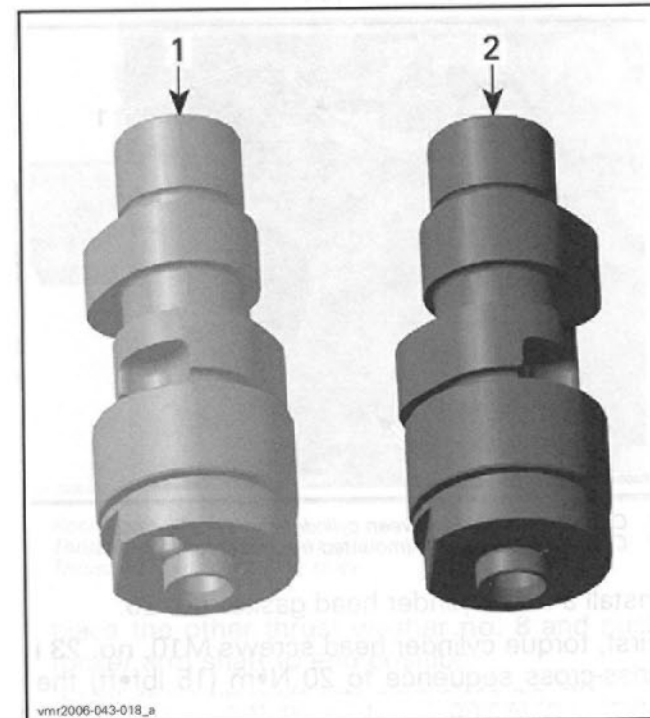

1. Camshaft of cylinder 2, rear
2. Camshaft of cylinder 1, front

Removal

The removal procedure is the same for both camshafts.

Each camshaft is different in design. Thus, it is important not to mix up any parts of the camshaft assembly with that of the other cylinder. Keep parts as a group.

Remove:

- valve cover (see *VALVE COVER* above)
- chain tensioner (see *CHAIN TENSIONER* above)
- camshaft timing gear (see *CAMSHAFT TIMING GEAR* above)
- camshaft retaining plate

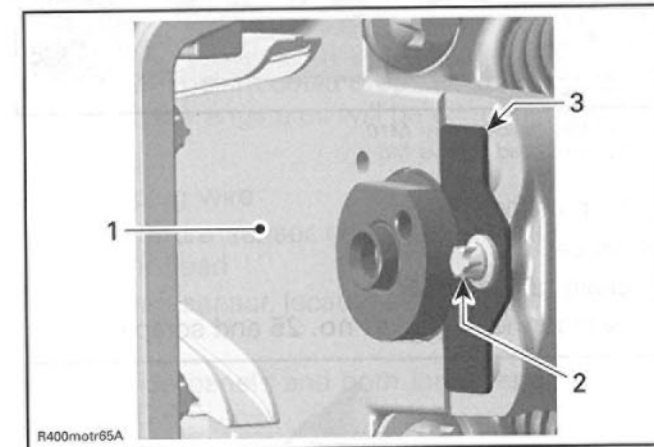

1. Cylinder head
2. Allen screws
3. Camshaft retaining plate

- rocker arms (see *ROCKER ARM* above)
- camshaft.

NOTE: For removal rotate camshaft so that intake/exhaust lobe shows to upper side of cylinder head.

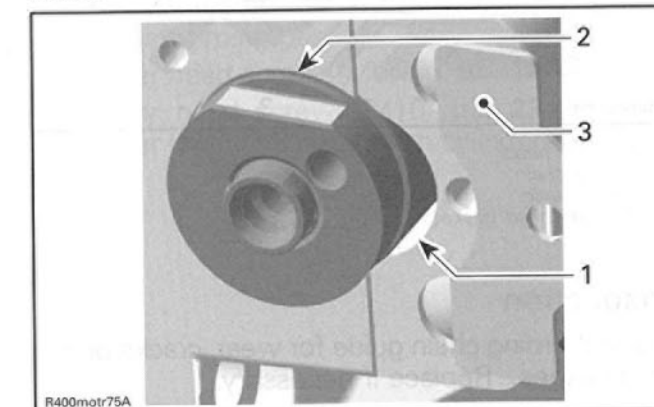

1. Area for camshaft lobes
2. Camshaft
3. Camshaft retaining plate

Inspection

Check each lobe and bearing journal of camshaft for scoring, scuffing, cracks or other signs of wear.

Measure camshaft bearing journal diameter and lobe height using a micrometer.

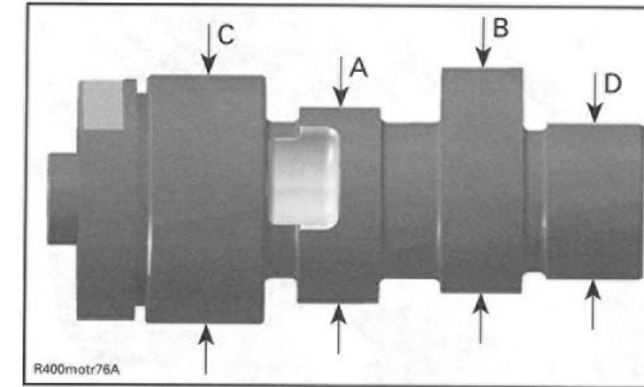

A. Camshaft lobe (exhaust valves)
B. Camshaft lobe (intake valves)
C. Camshaft bearing journal timing chain side
D. Camshaft bearing journal spark plug side

CAMSHAFT LOBE — EXHAUST VALVES	
Minimum New	31.940 mm (1.2575 in)
Maximum New	32.140 mm (1.2654 in)
Service limit	31.920 mm (1.2567 in)
CAMSHAFT LOBE — INTAKE VALVES	
Minimum New	32.110 mm (1.2642 in)
Maximum New	32.310 mm (1.2721 in)
Service limit	32.090 mm (1.2634 in)
CAMSHAFT BEARING JOURNAL — TIMING CHAIN SIDE	
Minimum New	34.959 mm (1.3763 in)
Maximum New	34.975 mm (1.3770 in)
Service limit	34.950 mm (1.3760 in)
CAMSHAFT BEARING JOURNAL — SPARK PLUG SIDE	
Minimum New	21.959 mm (.8645 in)
Maximum New	21.980 mm (.8654 in)
Service limit	21.950 mm (.8642 in)

Measure clearance between both ends of camshaft and cylinder head.

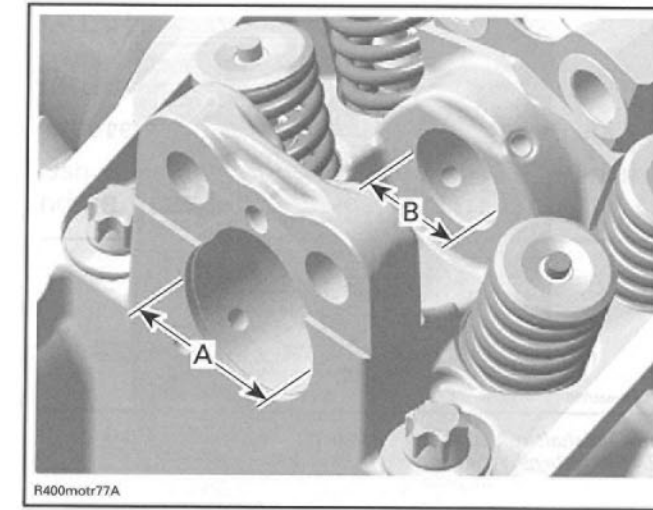

A. Cylinder head — camshaft bore timing chain side
B. Cylinder head — camshaft bore spark plug side

CAMSHAFT BORE — TIMING CHAIN SIDE MEASURED IN DIAMETER	
Minimum New	35.000 mm (1.3780 in)
Maximum New	35.025 mm (1.3789 in)
Service limit	35.040 mm (1.3795 in)
CAMSHAFT BORE — SPARK PLUG SIDE MEASURED IN DIAMETER	
Minimum New	22.000 mm (.8661 in)
Maximum New	22.021 mm (.8670 in)
Service limit	22.040 mm (.8677 in)

Replace parts that are not within specifications.

Installation

For installation, reverse the removal procedure. Pay attention to the following details.

CAUTION: The camshafts are not identical in design. Do not invert the camshafts during assembly. Any mix-up of the components will lead to engine damage.

Place the camshaft retaining plate in the slot of the camshaft.

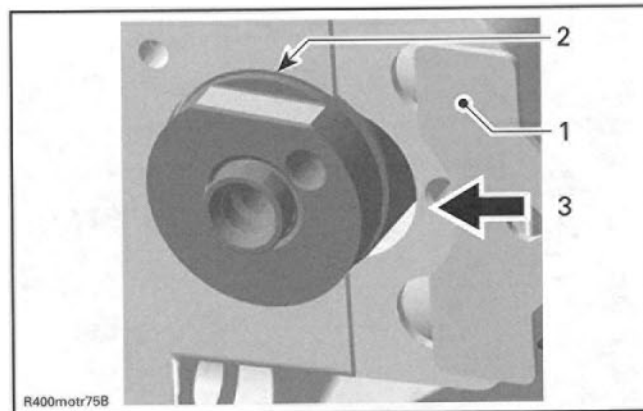

1. Camshaft retaining plate position
2. Slot retaining camshaft
3. Direction of movement

For other parts, refer to proper installation procedure.

VALVE SPRING

Removal

Remove:

- rocker arms (see *ROCKER ARM* above)
- cylinder head (see *CYLINDER HEAD* above).

Compress valve spring no. 11; use valve spring compressor clamp (P/N 529 035 724) and valve spring compressor cup (P/N 529 035 725).

WARNING

Always wear safety glasses when disassembling valve springs. Be careful when unlocking valves. Components could fly away because of the strong spring preload.

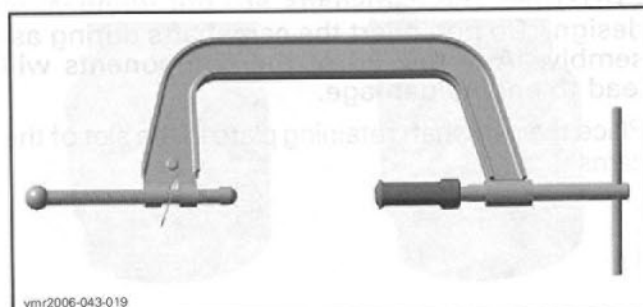

vmr2006-043-019

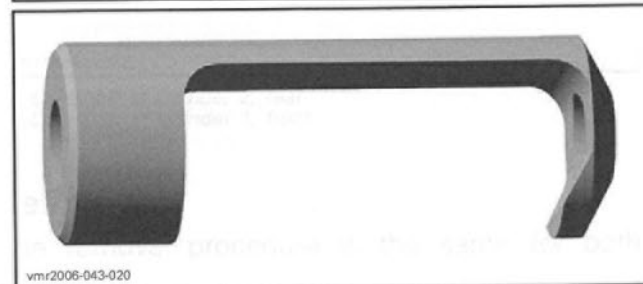

vmr2006-043-020

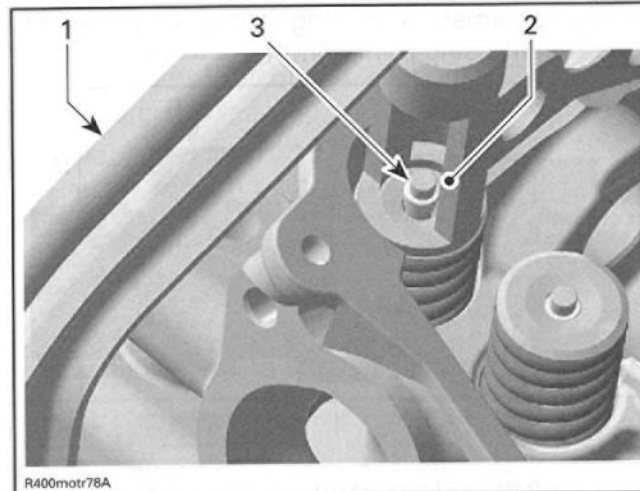

1. Valve spring compressor clamp
2. Valve spring compressor cup
3. Valve cotter

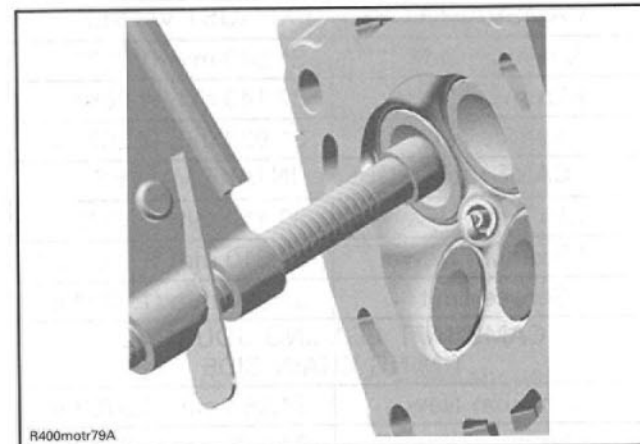

R400motr79A

LOCATE VALVE SPRING COMPRESSOR CLAMP IN CENTER OF THE VALVE

Remove valve cotters no. 9.

Withdraw valve spring compressor, valve spring retainer no. 10 and valve spring no. 11.

Inspection

Check valve spring for visible damages. If so, replace valve spring.

Check valve spring for free length and straightness.

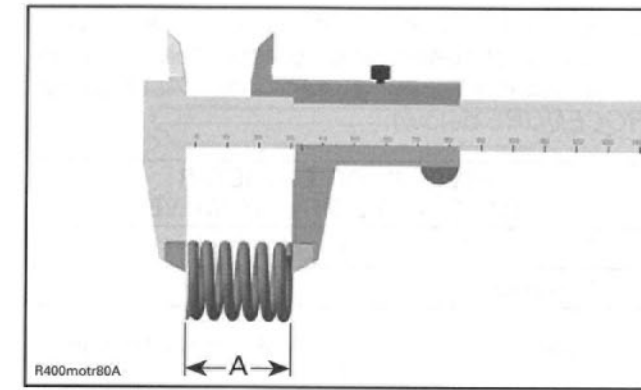

A. Valve spring length

VALVE SPRING FREE LENGTH	
Nominal New	40.81 mm (1.607 in)
Service limit	39.00 mm (1.535 in)

Replace valves springs if not within specifications.

Installation

For installation, reverse the removal procedure. Pay attention to the following details.

Colored area of the valve spring must be placed on top.

To ease installation of cotters, apply oil or grease on them so that they remain in place while releasing the spring.

NOTE: Valve cotter must be properly engaged in valve stem grooves.

After spring is installed, ensure it is properly locked by tapping on valve stem end with a soft hammer so that valve opens and closes a few times.

CAUTION: An improperly locked valve spring will cause engine damage.

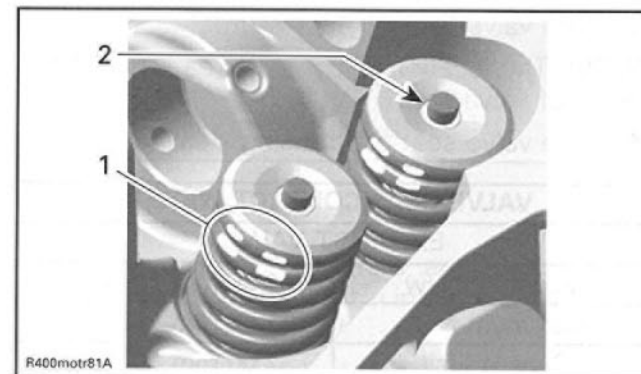

1. Position of the valve spring
2. Valve cotter

vmr2006-043

VALVE

Removal

Remove valve spring, see *VALVE SPRING* above.
Push valve stem, then pull valves no. 16 (intake) and no. 17 (exhaust) out of valve guide.

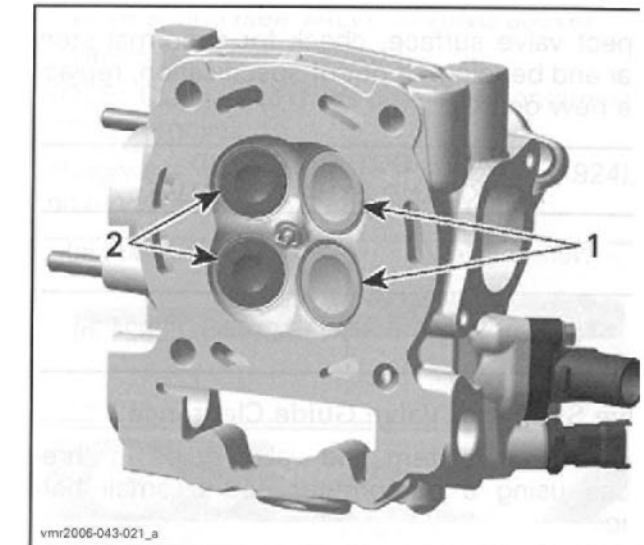

1. Intake valves 31 mm
2. Exhaust valves 27 mm

Remove valve stem seal no. 12 with Snap-ON pliers (P/N YA 8230).

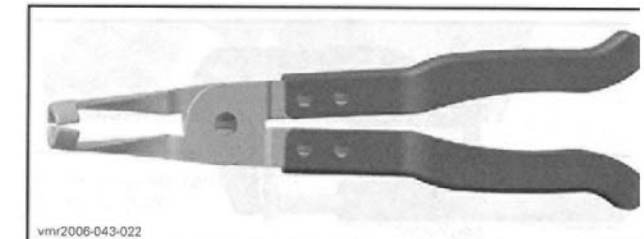

vmr2006-043-022



vmr2006-043-023

Inspection

Valve Stem Seal

Inspection of valve stem seals is not needed because new seals should always be installed whenever valves are removed.

Valve

Inspect valve surface, check for abnormal stem wear and bending. If out of specification, replace by a new one.

VALVE OUT OF ROUND INTAKE AND EXHAUST VALVE	
Nominal New	0.005 mm (.0002 in)
Service limit	0.06 mm (.0024 in)

Valve Stem and Valve Guide Clearance

Measure valve stem and valve guide in three places using a micrometer and a small bore gauge.

NOTE: Clean valve guide to remove carbon deposits before measuring.

Change valve if valve stem is out of specification or has other damages such as wear or friction surface.

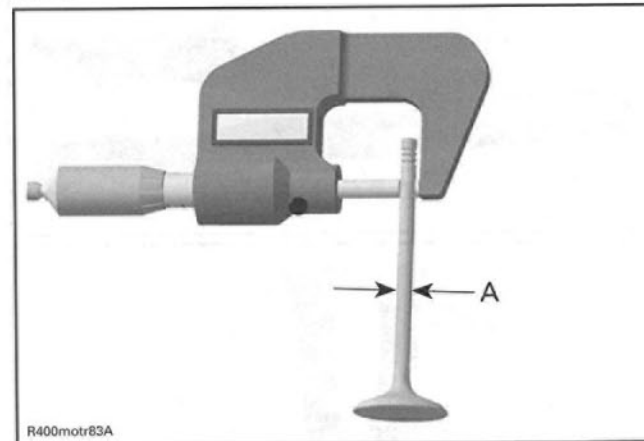

A. Valve stem diameter

VALVE STEM DIAMETER EXHAUST VALVE	
Minimum New	4.956 mm (.1951 in)
Maximum New	4.970 mm (.1957 in)
Service limit	4.930 mm (.1941 in)
INTAKE VALVE	
Minimum New	4.966 mm (.1955 in)
Maximum New	4.980 mm (.1960 in)
Service limit	4.930 mm (.1941 in)

Replace valve guide out of cylinder head if valve guide is out of specification or has other damages such as wear or friction surface (see **VALVE GUIDE PROCEDURE** below).

VALVE GUIDE DIAMETER INTAKE AND EXHAUST VALVE	
Minimum New	5.006 mm (.1971 in)
Maximum New	5.018 mm (.1976 in)
Service limit	5.050 mm (.1988 in)

Valve Face and Seat

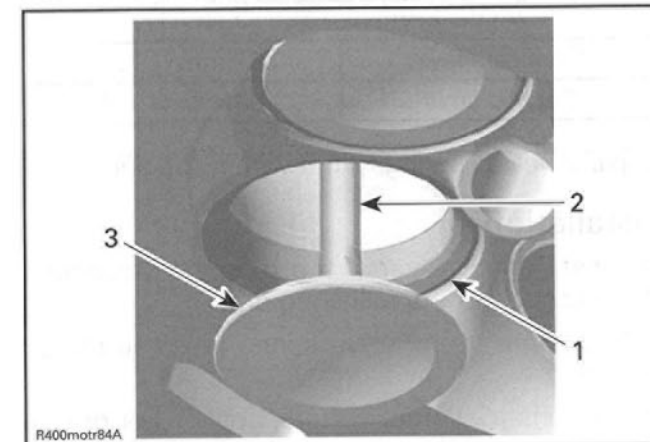

1. Valve seat
2. Exhaust valve contaminated area
3. Valve face (contact surface to valve seat)

Check valve face and seat for burning or pittings and replace valve or cylinder head if there are signs of damage.

Ensure to seat valves properly. Apply some lapping compound to valve face and work valve on its seat with a lapping tool (see **VALVE GUIDE PROCEDURE** below).

Measure valve face contact width.

NOTE: The location of contact area should be in center of valve seat.

Measure valve seat width using a caliper.

VALVE SEAT CONTACT WIDTH EXHAUST VALVE	
Minimum New	1.25 mm (.049 in)
Maximum New	1.55 mm (.061 in)
Service limit	2.00 mm (.078 in)
INTAKE VALVE	
Minimum New	1.05 mm (.041 in)
Maximum New	1.35 mm (.053 in)
Service limit	1.80 mm (.070 in)

**VALVE GUIDE REPLACEMENT
PROCEDURE**

Removal

Remove:

- cylinder head (see **CYLINDER HEAD** above)
- valve spring (see **VALVE SPRING** above)
- valves (see **VALVE** above).

NOTE: Clean valve guide area from contamination before removal.

Using valve guide remover (P/N 529 035 924), remove valve guide with a hammer.

If valve seat contact width is too wide or has dark spots, replace the cylinder head.

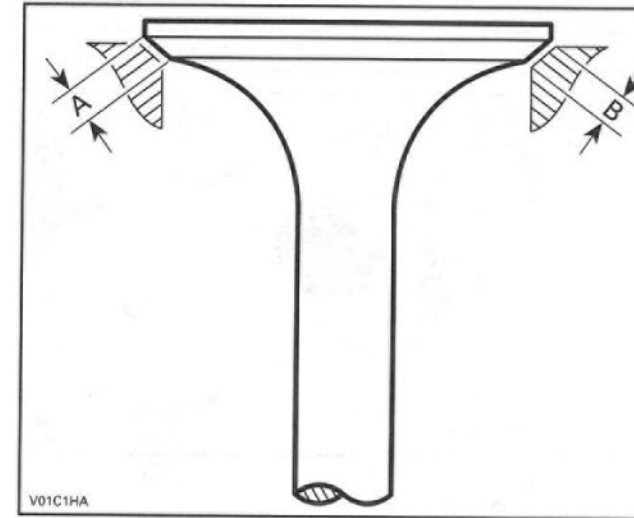

- A. Valve face contact width
- B. Valve seat contact width

Installation

For installation, reverse the removal procedure. Pay attention to the following details.

CAUTION: Make sure the thrust washer no. 13 is installed before installing valve stem seal no. 12.

Apply engine oil on valve stem and install it.

CAUTION: Be careful when valve stem is passed through sealing lips of valve stem seal.

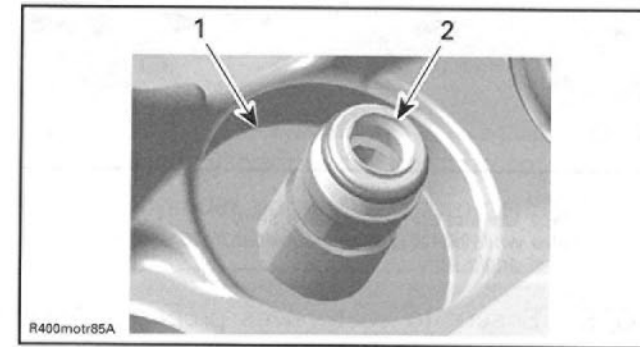

1. Thrust washer
2. Sealing lips of valve stem seal

To ease installation of cotters, apply oil or grease on them so that they remain in place while releasing the spring.

After spring is installed, ensure it is properly locked by tapping on valve stem end with a soft hammer so that valve opens and closes a few times.

CAUTION: An improperly locked valve spring will cause engine damage.

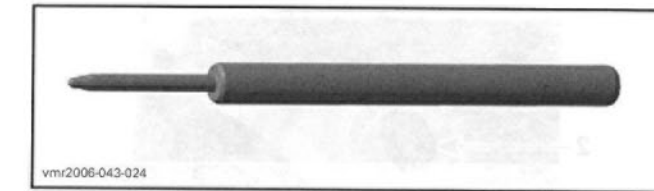

vnr2006-043-024

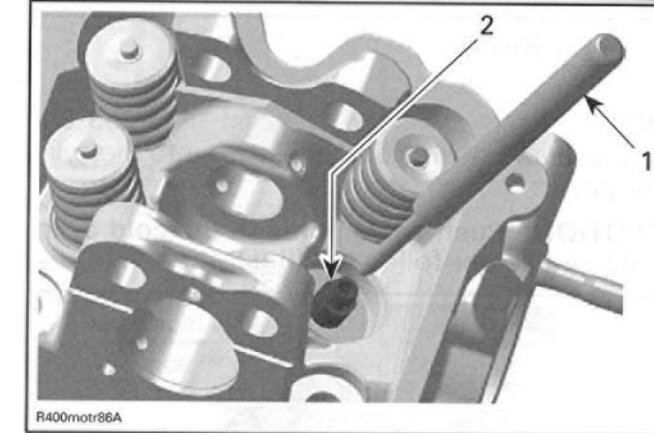

1. Valve guide remover
2. Valve guide

Inspection

Always replace valve stem seals whenever valve guides are removed.

Clean the valve guide bore before reinstalling the valve guide into cylinder head.

Installation

For installation, reverse the removal procedure. Pay attention to the following details.

Use valve guide installer (P/N 529 035 853) to install valve guide.

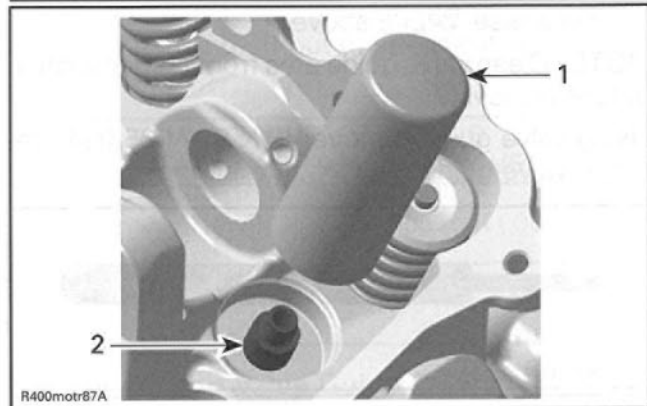

1. Valve guide installer
2. Valve guide

NOTE: Apply anti-seize lubricant (P/N 293 800 070) on valve guide prior to install it into the cylinder head.

CAUTION: Push valve guide in the cold cylinder head as per following illustration.

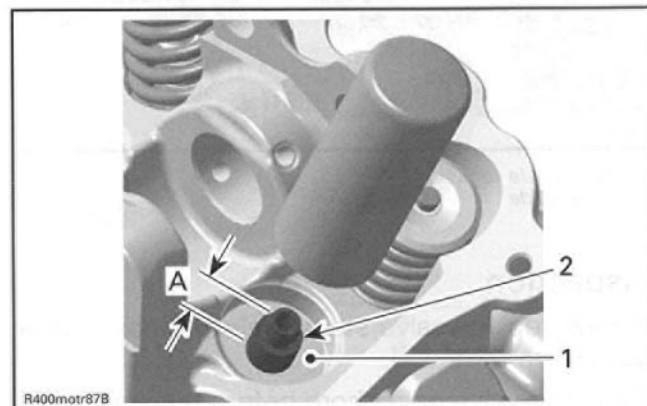

1. Thrust surface of cylinder head
2. Valve guide
A. Measurement from thrust surface to valve guide top

VALVE GUIDE MEASUREMENT A	
Minimum New	14.00 mm (.5512 in)
Maximum New	14.40 mm (.5669 in)

Valve guide to be adjusted in diameter by using a reamer.

VALVE GUIDE DIAMETER — INTAKE AND EXHAUST VALVE	
Minimum New	5.006 mm (.1971 in)
Maximum New	5.018 mm (.1976 in)

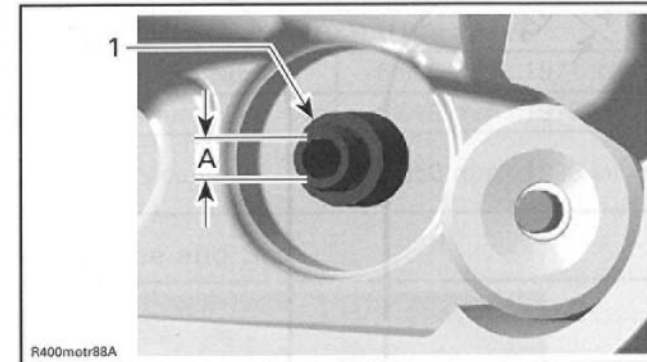

1. Valve guide
A. Valve guide diameter

NOTE: Ensure to turn reamer in the right direction. Use cutting oil and make brakes to clean reamer/valve guide from metal shavings.

Apply some lapping compound to valve face and work valve on its seat with a lapping tool.

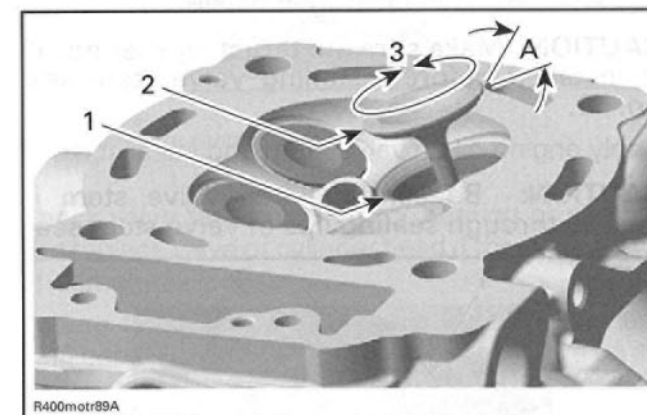

1. Valve seat
2. Valve face (contact surface to valve seat)
3. Turn valve while pushing against cylinder head
A. Valve seat angle 45°

NOTE: Ensure to seat valves properly. Apply marking paste to ease checking contact pattern.

Repeat procedure until valve seat/valve face fits together.

CYLINDER

Removal

Lock crankshaft with crankshaft locking bolt (P/N 529 035 926), see *CRANKSHAFT LOCKING PROCEDURE* and *CAMSHAFT TIMING PROCEDURE* above.

CYLINDER TAPER IN DIAMETER	
Maximum New	0.038 mm (.0015 in)
Service limit	0.090 mm (.0035 in)

Distance between measurements should not exceed the service limit mentioned above.

Cylinder Out of Round

Measure cylinder diameter in piston axis direction from top of cylinder. Take another measurement 90° from first one and compare.

NOTE: Take the same measuring points like described in *CYLINDER TAPER* above.

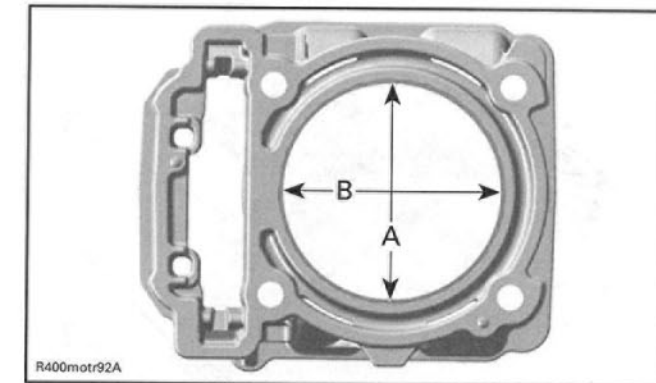

A. Perpendicular to crankshaft axis
B. Parallel to crankshaft axis

CYLINDER OUT OF ROUND	
Maximum New	0.015 mm (.0006 in)
Service limit	0.020 mm (.0008 in)

Installation

For installation, reverse the removal procedure. Pay attention to the following details.

CAUTION: Always replace cylinder base gasket before installing the cylinder.

First mount cylinder 2, rear. Then remove crankshaft locking bolt (P/N 529 035 926). Crank the engine further and position piston 1, front at TDC. Mount cylinder 1, front. The cylinder can not be pushed fully over the piston unless the piston is located at TDC.

Apply engine oil in the bottom area of the cylinder bore and also on the band of the piston ring compressor tool.

Use piston ring compressor tool (P/N 529 035 919) and slide piston into cylinder.

Remove:

- chain tensioner (see *CHAIN TENSIONER* above)
- camshaft timing gear (see *CAMSHAFT TIMING GEAR* above)
- cylinder head (see *CYLINDER HEAD* above).

Pull cylinder.

Discard cylinder base gaskets.

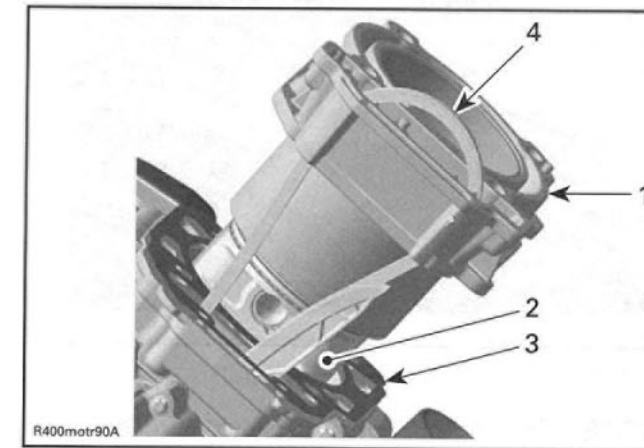

1. Cylinder
2. Piston assembly
3. Cylinder base gasket
4. Camshaft timing chain

Inspection

Cylinder

Check cylinder for cracks, scoring and wear ridges on the top and bottom of the cylinder. If so, replace cylinder.

Cylinder Taper

Measure cylinder bore and if it is out of specifications, replace cylinder and piston ring set no. 27.

Measure cylinder bore at 3 recommended positions. See the following illustration.

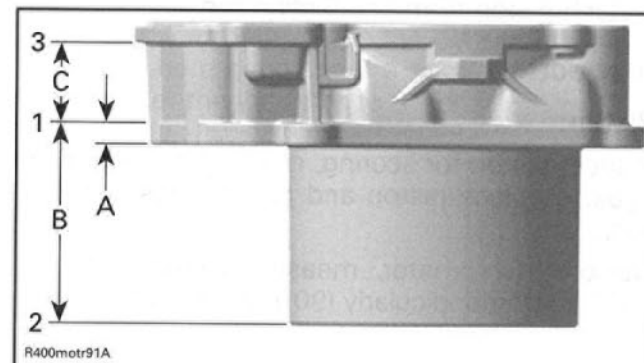

1. First measuring of diameter
2. Second measuring of diameter
3. Third measuring of diameter
A. 7 mm (.276 in) from cylinder bottom
B. 68 mm (2.68 in)
C. 32 mm (1.260 in)

Section 01 V-810 ENGINE
Subsection 05 (CYLINDER AND HEAD)

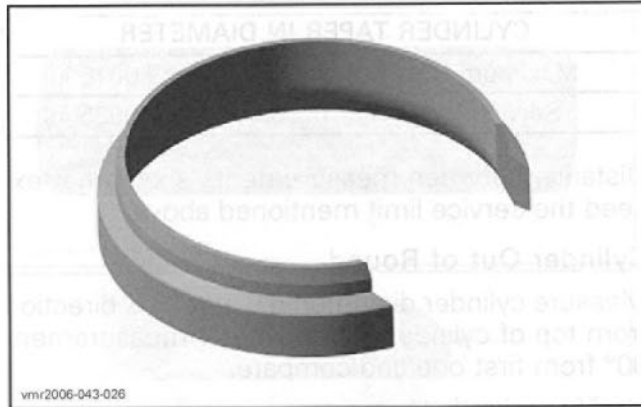

vmr2006-043-026

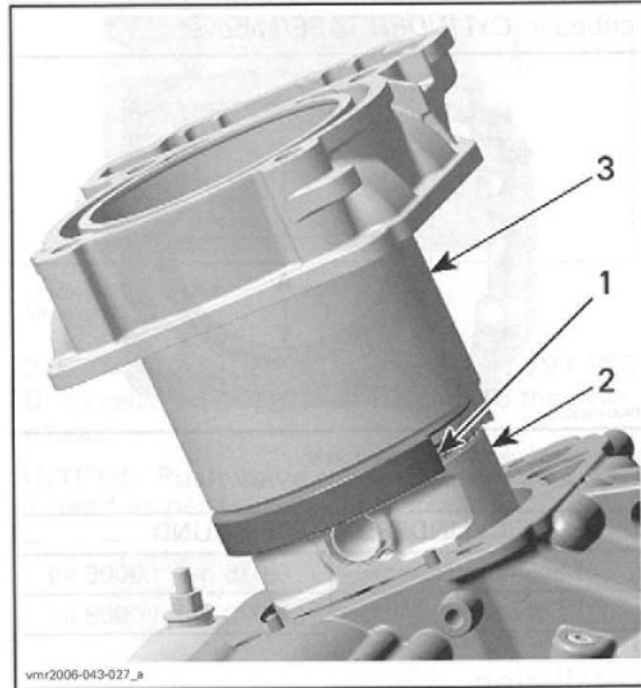

1. Piston ring compressor tool
2. Piston
3. Cylinder

NOTE: Put timing chain through the chain pit then put the cylinder in place.

CAUTION: Chain guide has to be fixed between cylinder and cylinder head.

Install cylinder head and the other parts in accordance with the proper installation procedures.

PISTON

Removal

Remove:

- cylinder head (see *CYLINDER HEAD* above)
- cylinder (see *CYLINDER* above).

Place a rag under piston and in the area of timing chain compartment.

WARNING

Piston circlips are spring loaded.

Remove one piston circlip and discard it.

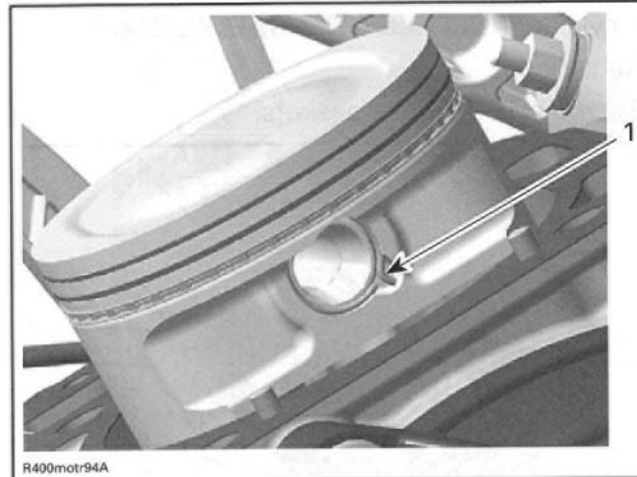

R400motr94A

1. Piston circlip

NOTE: The removal of both piston circlips is not necessary to remove piston pin.

Push piston pin out of piston.

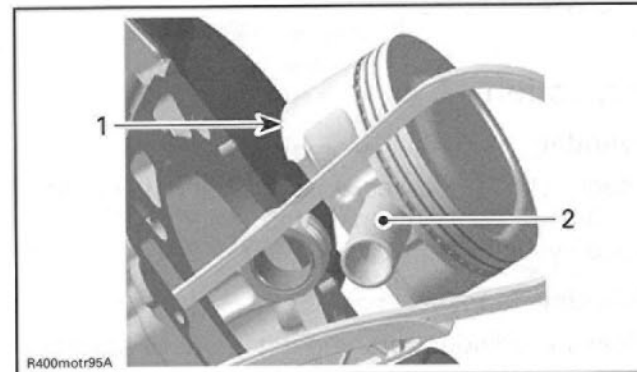

R400motr95A

1. Piston
2. Piston pin

Detach piston from connecting rod.

Inspection

Piston

Inspect piston for scoring, cracking or other damages. Replace piston and piston rings if necessary.

Using a micrometer, measure piston at 8 mm (.315 in) perpendicularly (90°) to piston pin.

Section 01 V-810 ENGINE
Subsection 05 (CYLINDER AND HEAD)

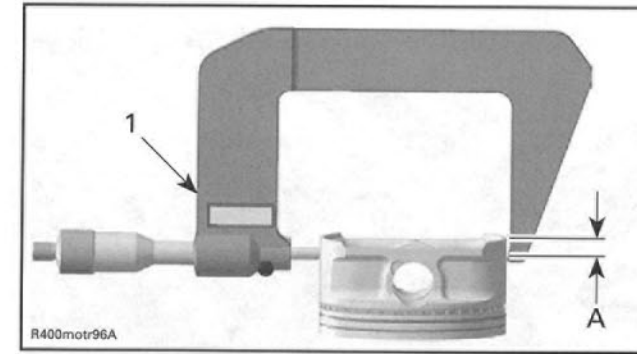

1. Measuring perpendicularly (90°) to piston pin
A. 8 mm (.315 in)

The measured dimension should be as described in the following table. If not, replace piston.

PISTON MEASUREMENT	
Minimum New	90.950 mm (3.5807 in)
Maximum New	90.966 mm (3.5813 in)
Service limit	90.850 mm (3.577 in)

Piston/Cylinder Clearance

Adjust and lock a micrometer to the piston dimension.

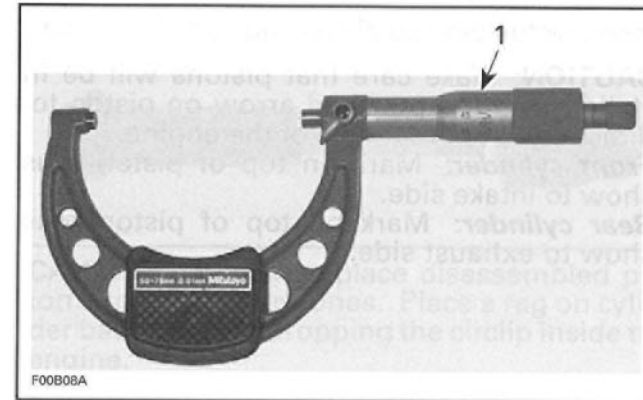

1. Micrometer set to the piston dimension

With the micrometer set to the dimension, adjust a cylinder bore gauge to the micrometer dimension and set the indicator to 0 (zero).

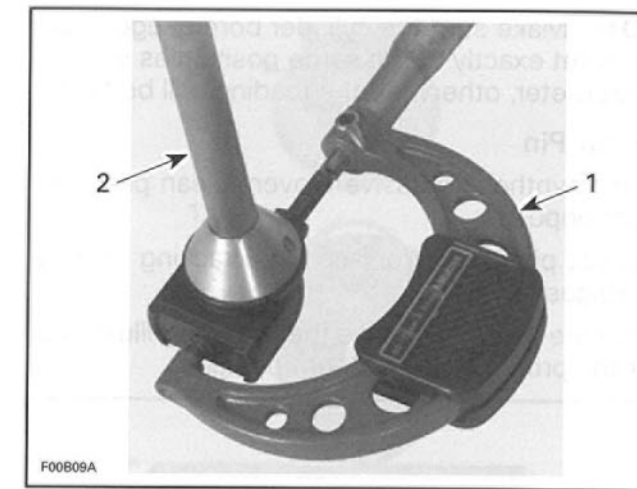

1. Use the micrometer to set the cylinder bore gauge
2. Dial bore gauge

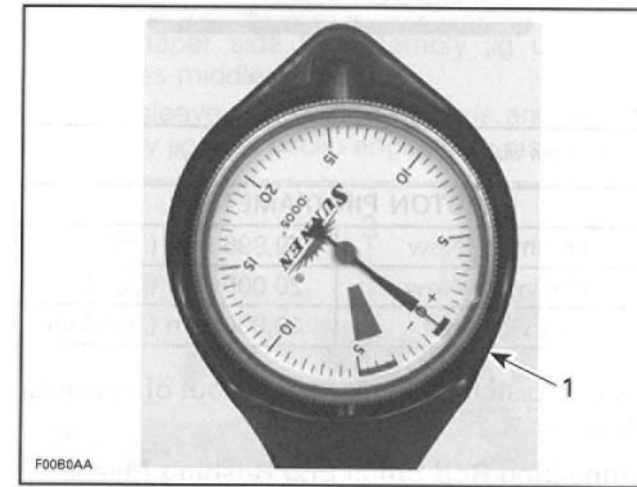

TYPICAL
1. Indicator set to 0 (zero)

Position the dial bore gauge 20 mm (.787 in) above cylinder base, measuring perpendicularly (90°) to piston pin axis.

Read the measurement on the cylinder bore gauge. The result is the exact piston/cylinder wall clearance.

PISTON/CYLINDER CLEARANCE	
Minimum New	0.027 mm (.0011 in)
Maximum New	0.057 mm (.0022 in)
Service limit	0.100 mm (.0040 in)

NOTE: Make sure used piston is not worn. See *PISTON MEASUREMENT* above.

If clearance exceeds specified tolerance, replace piston by a new one and measure piston/cylinder clearance again.

Section 01 V-810 ENGINE
Subsection 05 (CYLINDER AND HEAD)

NOTE: Make sure the cylinder bore gauge indicator is set exactly at the same position as with the micrometer, otherwise the reading will be false.

Piston Pin

Using synthetic abrasive woven, clean piston pin from deposits.

Inspect piston pin for scoring, cracking or other damages.

Measure piston pin. See the following illustration for the proper measurement positions.

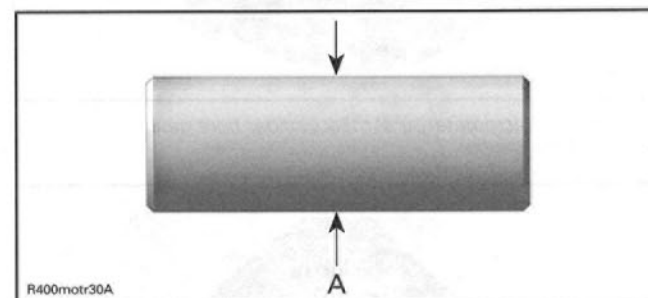

A. Piston pin diameter

PISTON PIN DIAMETER	
Minimum New	19.996 mm (.7872 in)
Maximum New	20.000 mm (.7874 in)
Service limit	19.980 mm (.7866 in)

Replace piston pin if diameter is out of specifications.

Connecting Rod Small End Bushing Measure Inside Diameter of Connecting Rod

CONNECTING ROD SMALL END DIAMETER	
Minimum New	20.010 mm (.7878 in)
Maximum New	20.020 mm (.7882 in)
Service limit	20.060 mm (.7898 in)

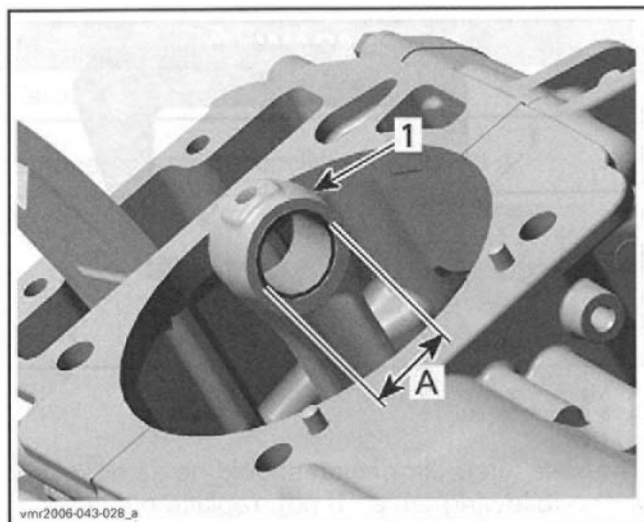

1. Connecting rod small end
A. Connecting rod small end diameter

Replace connecting rod if diameter of connecting rod small end is out of specifications. Refer to **BOTTOM END** for removal procedure.

Installation

For installation, reverse the removal procedure. Pay attention to the following details.

Apply engine oil on the piston pin.

Insert piston pin into piston and connecting rod.

CAUTION: Take care that pistons will be installed with the punched arrow on piston top direction to the rear side of the engine.

Front cylinder: Mark on top of piston must show to intake side.

Rear cylinder: Mark on top of piston must show to exhaust side.

Section 01 V-810 ENGINE
Subsection 05 (CYLINDER AND HEAD)

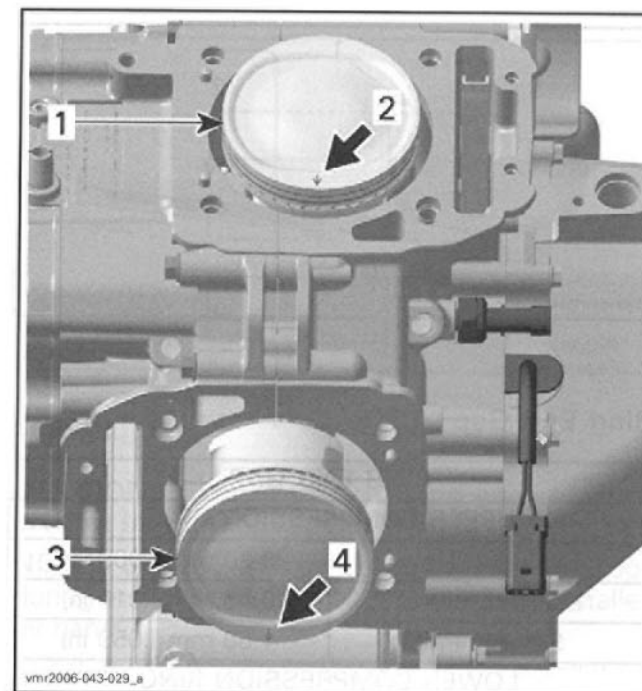

1. Piston of cylinder 1, front
2. Mark on piston must show to intake side of cylinder 1, front
3. Piston of cylinder 2, rear
4. Mark on piston must show to exhaust side of cylinder 2, rear

Use the piston circlip installer (P/N 529 035 921) to assemble the new piston circlip as per following procedure:



CAUTION: Always replace disassembled piston circlip(s) by new ones. Place a rag on cylinder base to avoid dropping the circlip inside the engine.

– place circlip no. 28 in sleeve as per following illustration

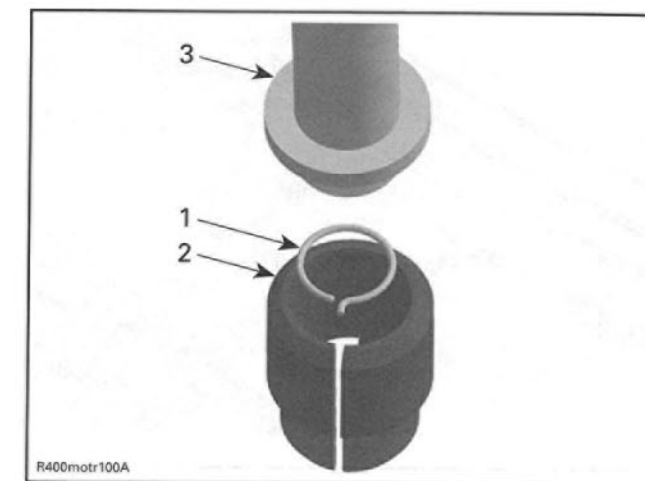

1. Circlip
2. Sleeve
3. Assembly jig from piston clip installer

- push taper side of assembly jig until circlip reaches middle of sleeve
- align sleeve with piston pin axis and push assembly jig until circlip engages in piston.

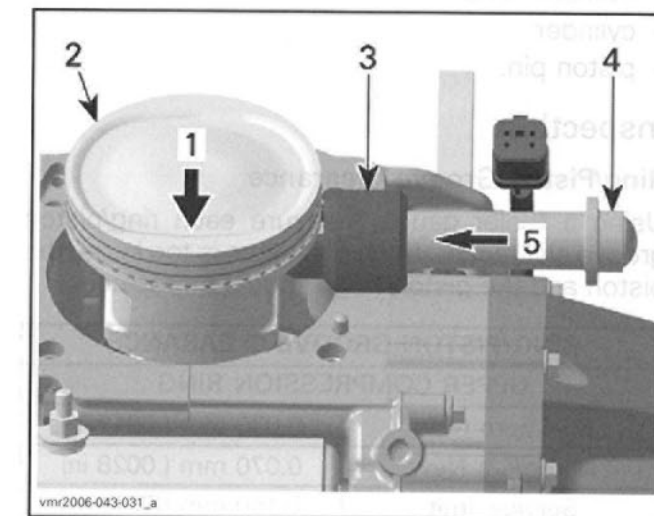

1. Arrow should indicate to engine rear side
2. Hold piston while pushing circlip in place
3. Sleeve
4. Assembly jig
5. Direction to push circlip

NOTE: Take care that the hook of the piston circlip is positioned properly.

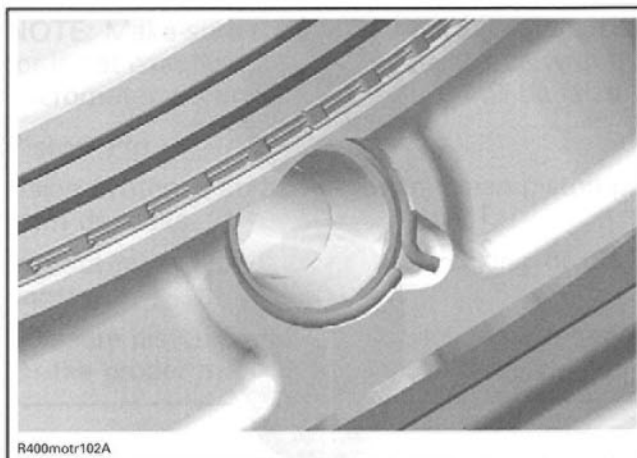

R400motr102A
CORRECT POSITION OF THE PISTON CIRCLIP

PISTON RINGS

Removal

- Remove:
- cylinder head
 - cylinder
 - piston pin.

Inspection

Ring/Piston Groove Clearance

Using a feeler gauge measure each ring/piston groove clearance. If the clearance is too large, the piston and the piston rings should be replaced.

RING/PISTON GROOVE CLEARANCE	
UPPER COMPRESSION RING	
Minimum New	0.030 mm (.0012 in)
Maximum New	0.070 mm (.0028 in)
Service limit	0.150 mm (.0059 in)
LOWER COMPRESSION RING	
Minimum New	0.020 mm (.0008 in)
Maximum New	0.060 mm (.0024 in)
Service limit	0.150 mm (.0059 in)
OIL SCRAPER RING	
Minimum New	0.010 mm (.0004 in)
Maximum New	0.045 mm (.0018 in)
Service limit	0.150 mm (.0059 in)

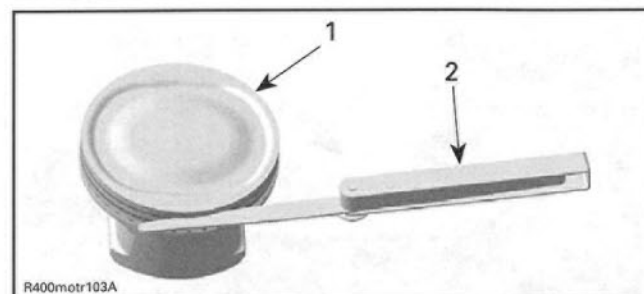

R400motr103A
1. Piston
2. Feeler gauge

Ring End Gap

RING END GAP	
UPPER COMPRESSION RING	
Minimum New	0.20 mm (.008 in)
Maximum New	0.40 mm (.016 in)
Service limit	1.50 mm (.059 in)
LOWER COMPRESSION RING	
Minimum New	0.20 mm (.008 in)
Maximum New	0.40 mm (.016 in)
Service limit	1.50 mm (.059 in)
OIL SCRAPER RING	
Minimum New	0.20 mm (.008 in)
Maximum New	0.70 mm (.028 in)
Service limit	1.50 mm (.059 in)

Measure position for ring end gap in the area of 8 to 16 mm (.315 to .630 in) from top of cylinder.

NOTE: In order to correctly position the ring in the cylinder, use piston as a pusher.

Using a feeler gauge, check ring end gap. Replace ring if gap exceeds above described specified tolerance.

Installation

For installation, reverse the removal procedure. Pay attention to the following details.

NOTE: First install spring and then rings of oil scraper ring.

Install the oil scraper ring first, then the lower compression ring with the word "N and TOP" facing up, then the upper compression ring with the word "N and TOP" facing up.

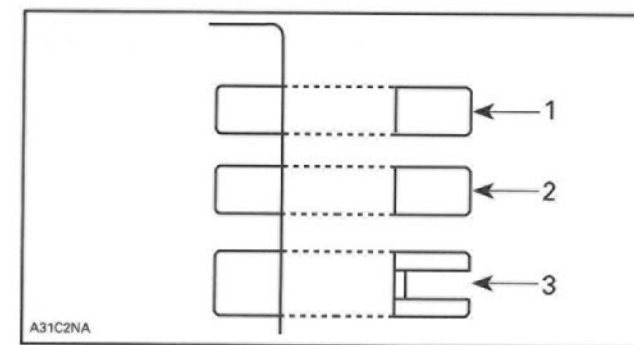

A31C2NA
1. Upper compression ring
2. Lower compression ring
3. Oil scraper ring

CAUTION: Ensure that top and second rings are not interchanged.

NOTE: Use a ring expander to prevent breakage during installation. The oil ring must be installed by hand.

Check that rings rotate smoothly after installation. Space the piston ring end gaps 120° apart and do not align the gaps with the piston pin bore or the thrust side axis.

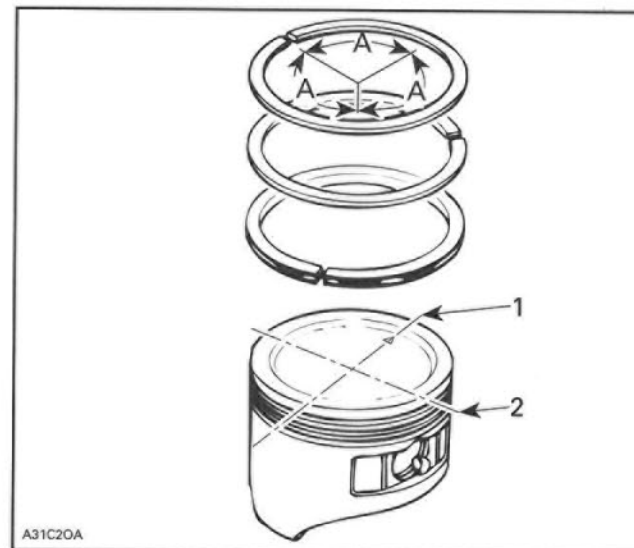

A31C20A
1. DO NOT align ring gap with piston thrust side axis
2. DO NOT align ring gap with piston pin bore axis
A. 120°

BOTTOM END

SERVICE TOOLS

Description	Part Number	Page
crankcase support sleeve	529 036 031	67
oil seal installer	529 036 033	62
plain bearing remover/installer	529 036 032	61
plain bearing remover/installer	529 035 917	67-68

Section 01 V-810 ENGINE
Subsection 06 (BOTTOM END)

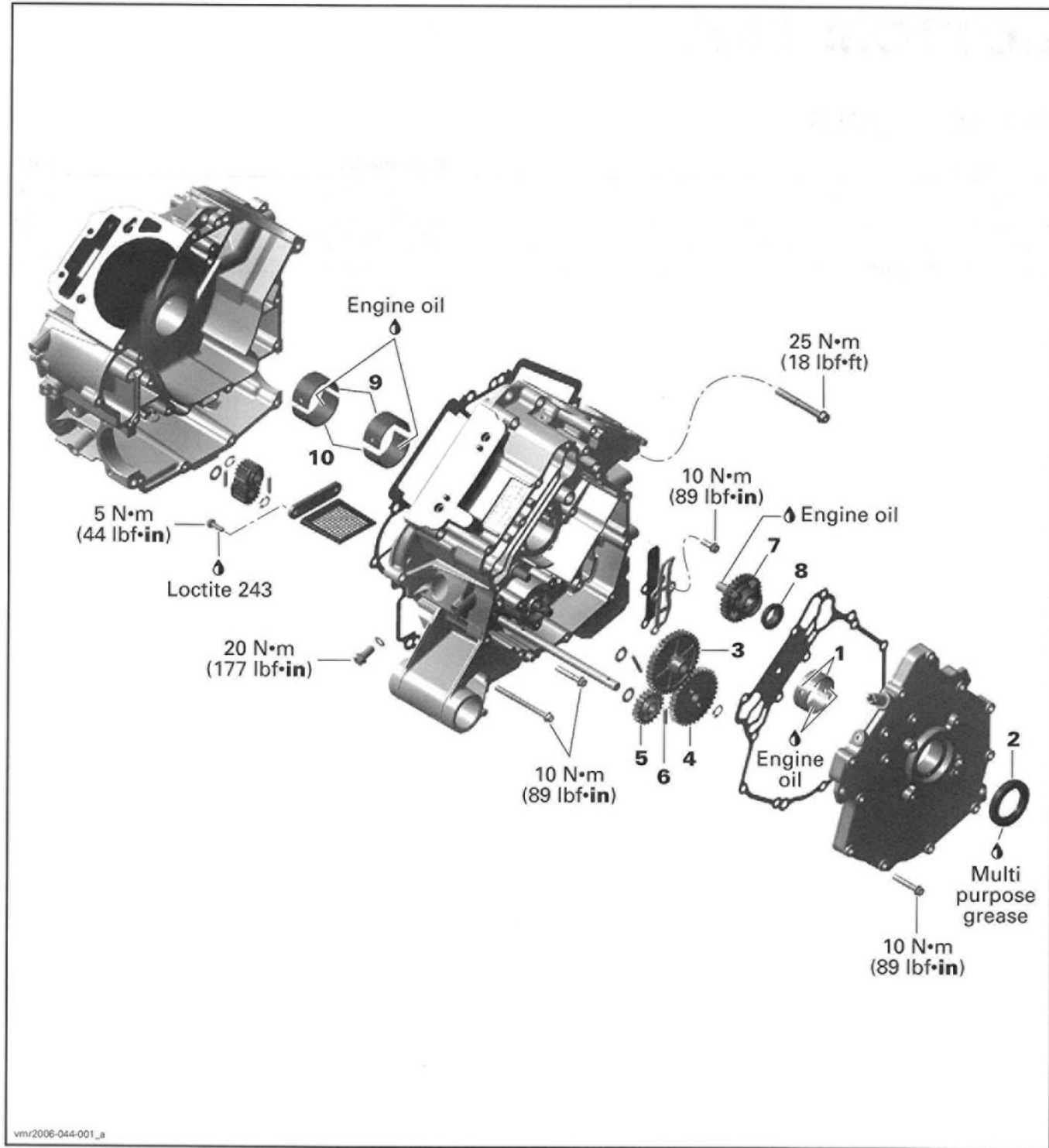

Section 01 V-810 ENGINE
Subsection 06 (BOTTOM END)

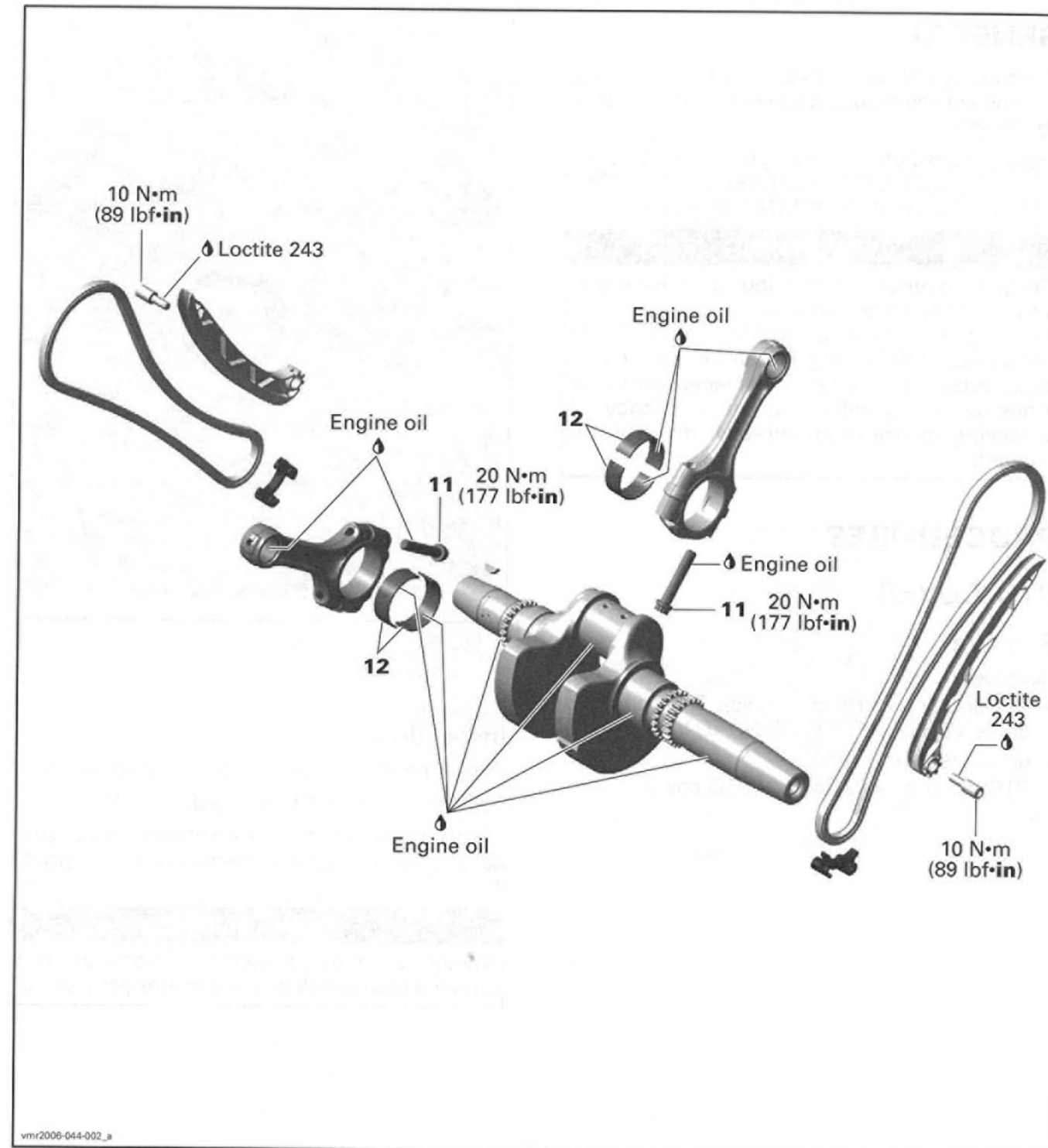

GENERAL

During assembly/installation, use the torque values and service products as shown in the exploded view(s).

Clean threads before applying a threadlocker. Refer to *SELF-LOCKING FASTENERS* and *LOCTITE APPLICATION* in *INTRODUCTION* section.

⚠ WARNING

Torque wrench tightening specifications must strictly be adhered to. Locking devices (e.g.: locking tabs, elastic stop nuts, self-locking fasteners, cotter pin, etc.) must be installed or replaced with new ones where specified. If the efficiency of a locking device is impaired, it must be renewed.

PROCEDURES

PTO COVER

Removal

- Remove:
- CVT and air guide (if applicable). Refer to appropriate *VEHICLE SHOP MANUAL*)
 - disconnect vent hose
 - PTO cover screws and pull PTO cover.

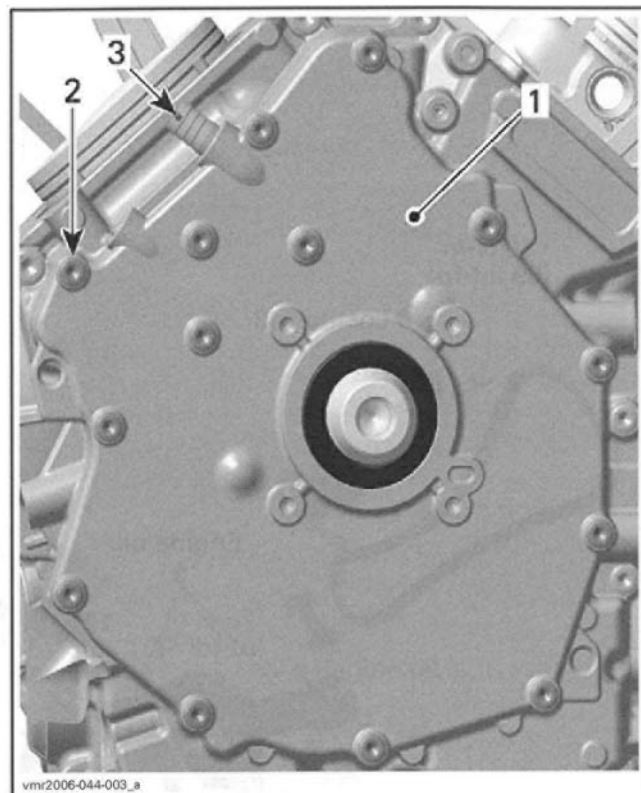

1. PTO cover
2. PTO cover screws
3. Vent hose nipple

Inspection

Check the PTO cover for cracks or other damage. Replace PTO cover if damaged.

Clean oil breather bore in PTO cover from contaminations with part cleaner then use an air gun to dry it.

⚠ WARNING

Always wear eye protector. Chemicals can cause a rash break out and injure your eyes.

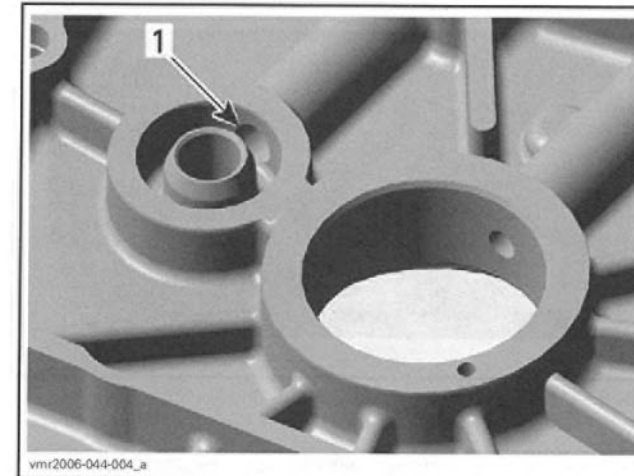

1. Oil breather bore

Check plain bearings no. 1 for scorings or other damages.

NOTE: Measure plain bearing inside diameter and compare to crankshaft journal diameter (PTO support bearing). Refer to *CRANKSHAFT* later in this section. Replace if the measurement is out of specification.

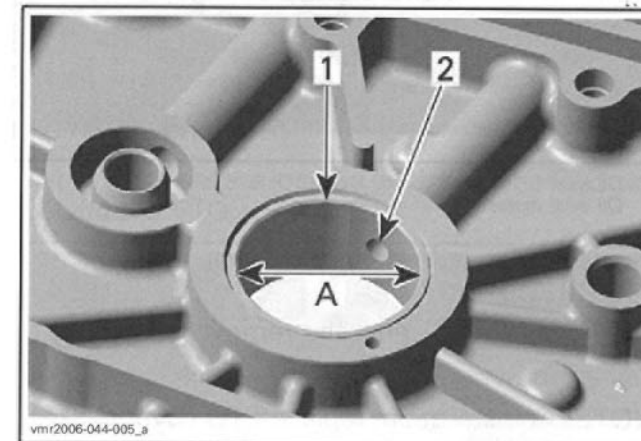

1. Plain bearing
 2. Oil bore
- A. Measure plain bearing inside diameter

PLAIN BEARING INSIDE DIAMETER (PTO side support bearing)	
SERVICE LIMIT	34.080 mm (1.3417 in)

Bearing Removal Procedure

Carefully remove the oil seal no. 2 with a screwdriver, without damaging the PTO cover.

Carefully push-out the plain bearings from the outside towards the inside using the plain bearing remover/installer (P/N 529 036 032).

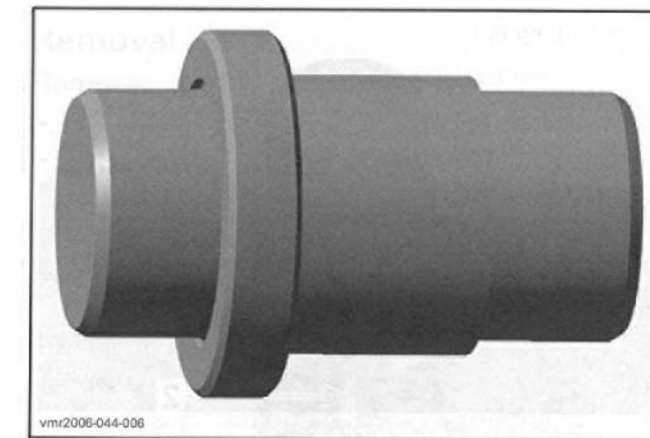

PLAIN BEARING REMOVER/INSTALLER — PTO COVER

The PTO cover has to be supported from below with suitable support with straight surface, in order to prevent damage of the sealing surface.

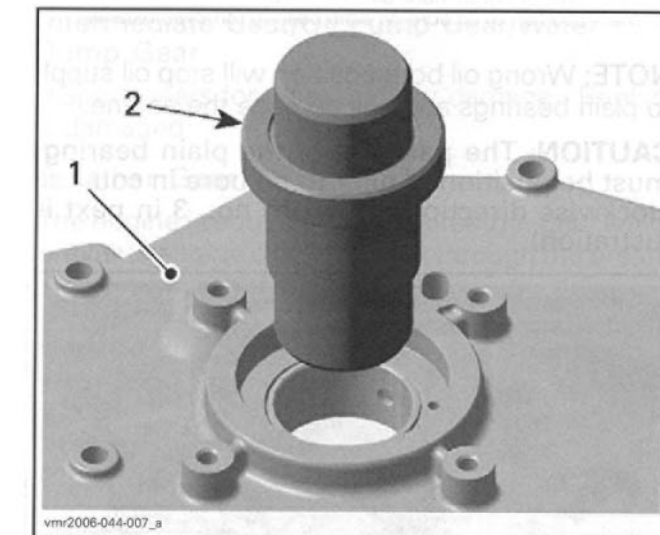

1. PTO cover
2. Plain bearing remover/installer

Bearing Installation Procedure

NOTE: Unless otherwise instructed, never use hammer to install plain bearings. Use press only.

Install plain bearings with the proper plain bearing remover/installer (P/N 529 036 032).

NOTE: Carefully press-in the plain bearings in the same direction as during disassembly, from the outside towards the inside. Support PTO cover with suitable support with straight surface, in order to prevent damage of the sealing surface.

CAUTION: Mark position of oil bore on PTO cover and on plain bearing remover/installer. Align mark on plain bearing remover/installer with mark on PTO cover.

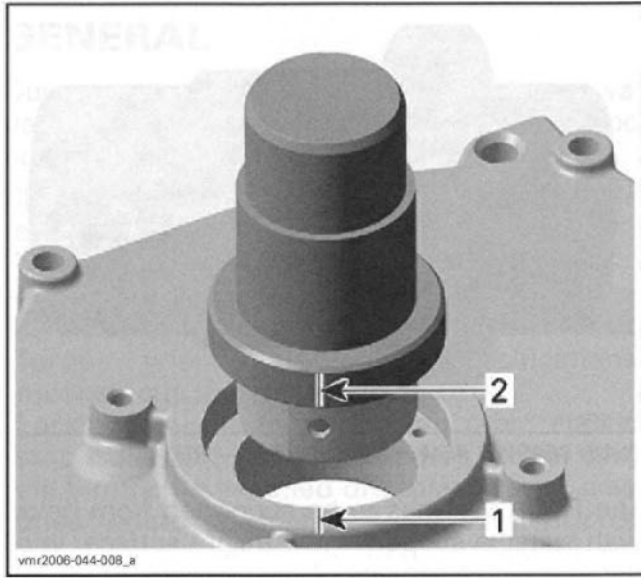

1. Mark position of oil bore on PTO cover
2. Mark position of oil bore on plain bearing remover/installer

NOTE: Wrong oil bore position will stop oil supply to plain bearings and will damage the engine.

CAUTION: The partition of the plain bearings must be positioned near to oil bore in counter-clockwise direction. (refer to no. 3 in next illustration).

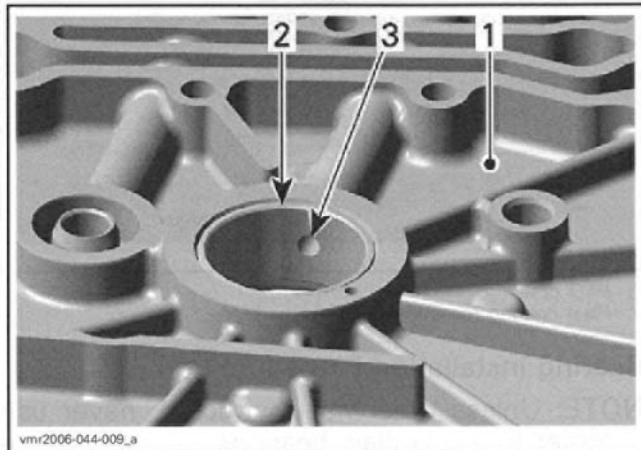

1. PTO cover (inside)
2. Partition
3. Oil bore

Oil Seal Installation Procedure

NOTE: At installation, replace PTO cover oil seal. Push PTO cover oil seal in place by using the oil seal installer (P/N 529 036 033).

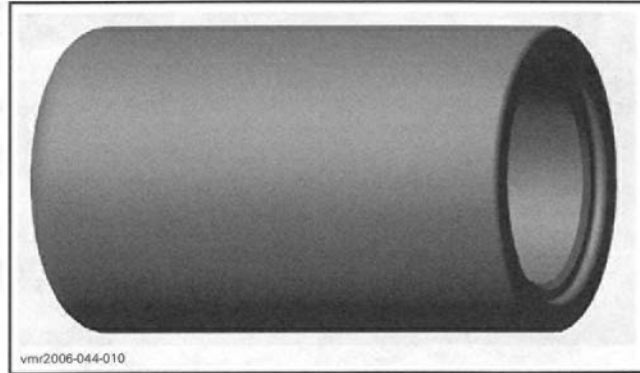

vmr2006-044-010
OIL SEAL INSTALLER — PTO COVER

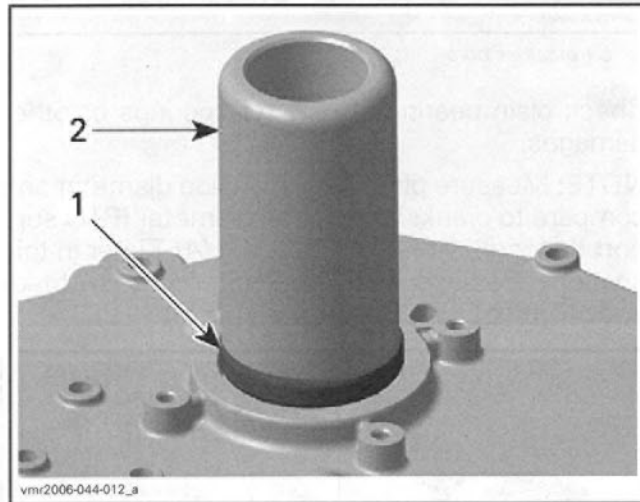

1. Oil seal
2. Oil seal installer

Installation

For installation, reverse the removal procedure. Pay attention to the following details.

NOTE: At installation, replace PTO cover gasket. Tightening sequence for screws on PTO cover is as per following illustration.

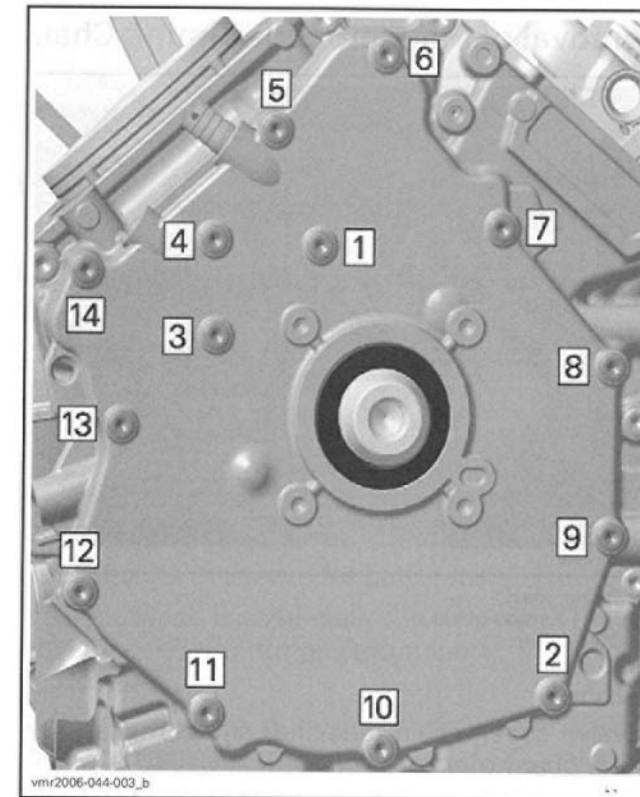

vmr2006-044-003_b
TIGHTENING SEQUENCE

DRIVE GEARS

The drive gears are located on the engine PTO side behind the PTO cover.

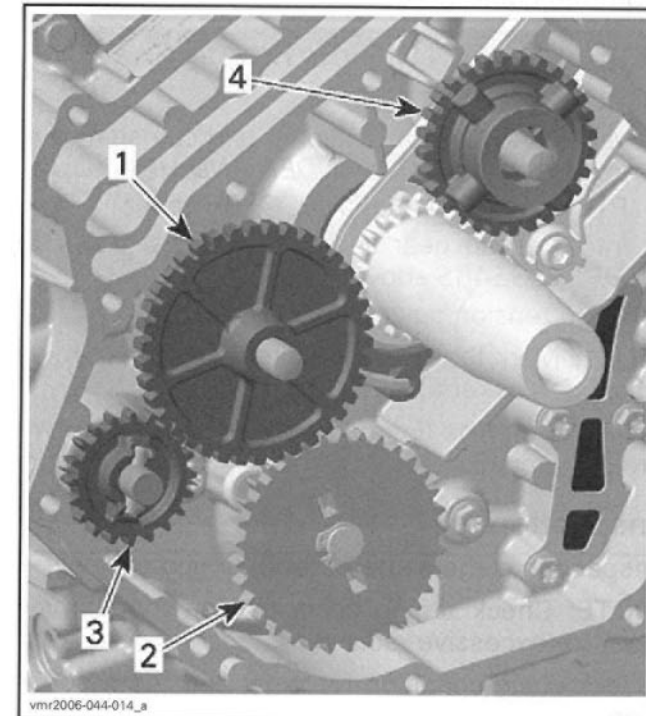

1. Intermediate gear
2. Oil pump gear
3. Water pump gear
4. Breather gear

Removal

Remove:

- PTO cover (refer to *PTO COVER* above)
- intermediate gear no. 3
- oil pump gear no. 4 (refer to *OIL PUMP* in *LUBRICATION SYSTEM*)
- water pump gear no. 5

To remove water pump gear, pull the shaft assembly a bit out and turn it about one teeth until it stays out.

Now you can push water pump gear down. Remove needle pin no. 6 and pull water pump gear out.

- breather gear no. 7.

Inspection

Intermediate Gear/Oil Pump Gear/Water Pump Gear

Inspect gears for wear or other damage. Replace if damaged.

Breather Gear

The engine is equipped with a breather gear which prevents engine oil coming out through the breathing system into the air box.

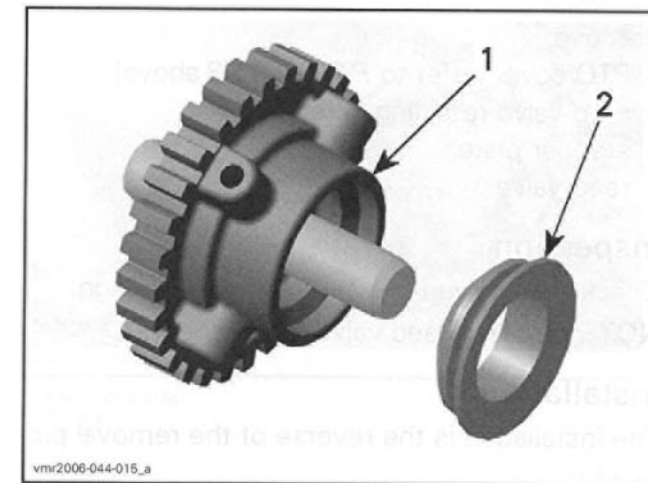

1. Breather gear
2. V-ring

Inspect gear for wear or other damage.

Check ball bearing for excessive play and smooth operation. Replace breather gear assembly if necessary.

Installation

The installation is essentially the reverse of the removal procedure, but pay attention to the following details.

NOTE: At installation replace the V-ring no. 8 of the breather gear.

Adequately oil the ball bearing of the breather gear.

REED VALVE

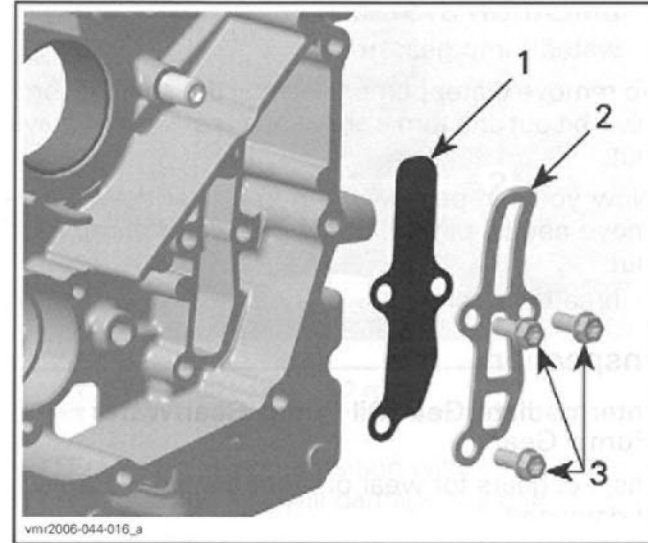

1. Reed valve
2. Stopper plate
3. Screws

Removal

Remove:

- PTO cover (refer to *PTO COVER* above)
- reed valve retaining screws
- stopper plate
- reed valve.

Inspection

Check reed valve for cracks or other damage.

NOTE: Replace reed valve if damaged.

Installation

The installation is the reverse of the removal procedure.

TIMING CHAIN

The engine is equipped with two timing chains. One of the timing chain is located on engine MAG side behind the magneto cover. The second timing chain is located on engine PTO side behind the PTO cover.

Removal of Magneto Side Timing Chain

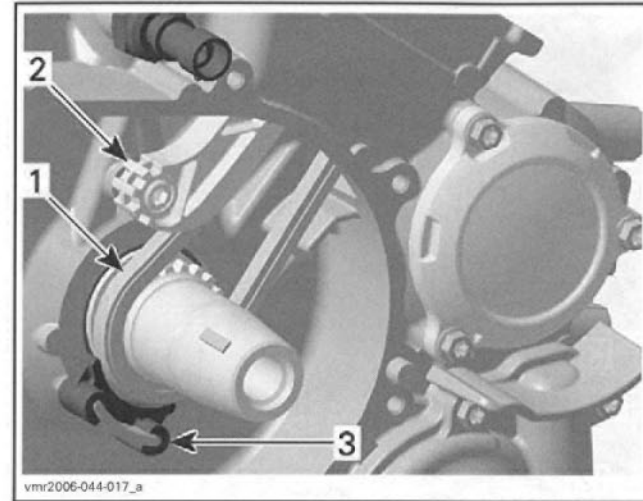

1. Timing chain
2. Chain tension guide
3. Chain guide

Remove:

- valve cover, chain tensioner and camshaft timing gear (refer to *CYLINDER AND HEAD*)
- magneto cover and rotor (refer to *MAGNETO SYSTEM*)
- chain tension guide and chain guide.

NOTE: Mark the operating direction of the timing chain before removal.

Carefully pull the timing chain sideward and down from the crankcase.

Removal of PTO Side Timing Chain

Remove:

- valve cover, chain tensioner and camshaft timing gear (refer to *CYLINDER AND HEAD*)
- PTO cover (refer to *PTO COVER* above)
- intermediate gear and breather gear (refer to *DRIVE GEARS* above)
- chain tension guide and chain guide.

NOTE: Mark the operating direction of the timing chain before removal.

Carefully pull the timing chain sideward and down from the crankcase.

Inspection

Inspection is the same for both timing chains.

NOTE: Check timing chain on camshaft timing gear for excessive radial play.

Check chain condition for wear and teeth condition.

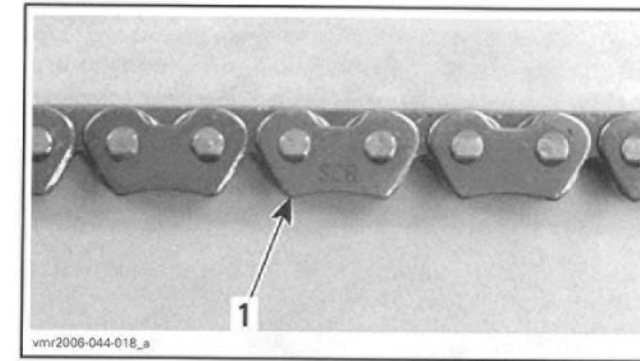

1. Timing chain

If chain is excessively worn or damaged, replace it as a set (camshaft timing gear and timing chain).

Installation

Installation is the same for both timing chains.

The installation is essentially the reverse of the removal procedure, but pay attention to the following details.

NOTE: Ensure to perform proper valve timing. Lock crankshaft and camshaft at TDC (refer to *CYLINDER AND HEAD*).

Install chain then, adjust chain tension (refer to *CYLINDER AND HEAD*).

CAUTION: Improper valve timing will damage engine components.

TIMING CHAIN GUIDE

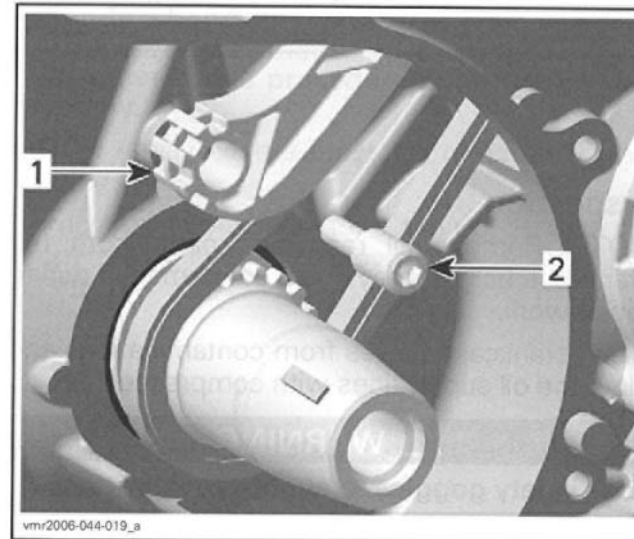

1. Timing chain guide
2. Bearing screw

Removal

Refer to *TIMING CHAIN* above.

Inspection

Check timing chain guide for wear, cracks or other damage. Replace if necessary.

Installation

The installation is the reverse of the removal procedure.

CRANKCASE

NOTE: Before disassembly, drain engine oil and engine coolant (refer to appropriate *VEHICLE SHOP MANUAL*).

Disassembly

Remove:

- PTO cover (refer to *PTO COVER* above)
- drive gears (refer to *DRIVE GEARS ABOVE*)

NOTE: Oil pump removal from crankcase is not necessary, but recommended to see condition of oil pump (refer to *LUBRICATION SYSTEM*).

- electric starter (refer to *ELECTRIC STARTER*)

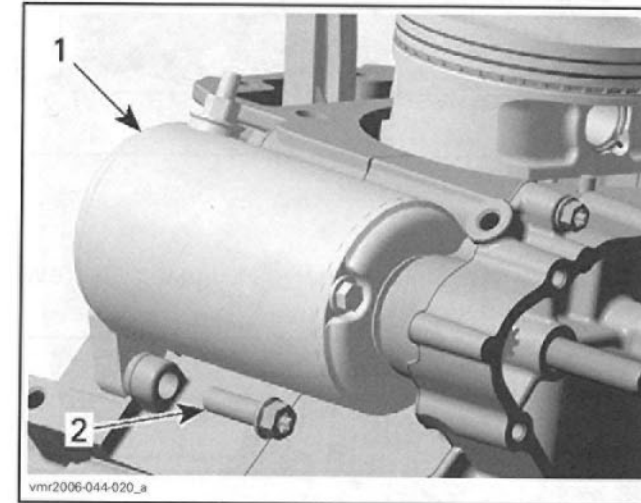

1. Electric starter
2. Screw

- magneto cover and rotor (refer to *MAGNETO SYSTEM*)
- electric starter drive gears (refer to *MAGNETO SYSTEM*)
- water pump housing (refer to *COOLING SYSTEM*) in this manual
- oil filter (refer to appropriate *VEHICLE SHOP MANUAL*)
- cylinder head and cylinder (refer to *CYLINDER AND CYLINDER HEAD*) in this manual

Section 01 V-810 ENGINE
Subsection 06 (BOTTOM END)

– timing chains and timing chain guides (refer to *TIMING CHAIN* and *TIMING CHAIN GUIDE* above).

Remove retaining screws of crankcase.

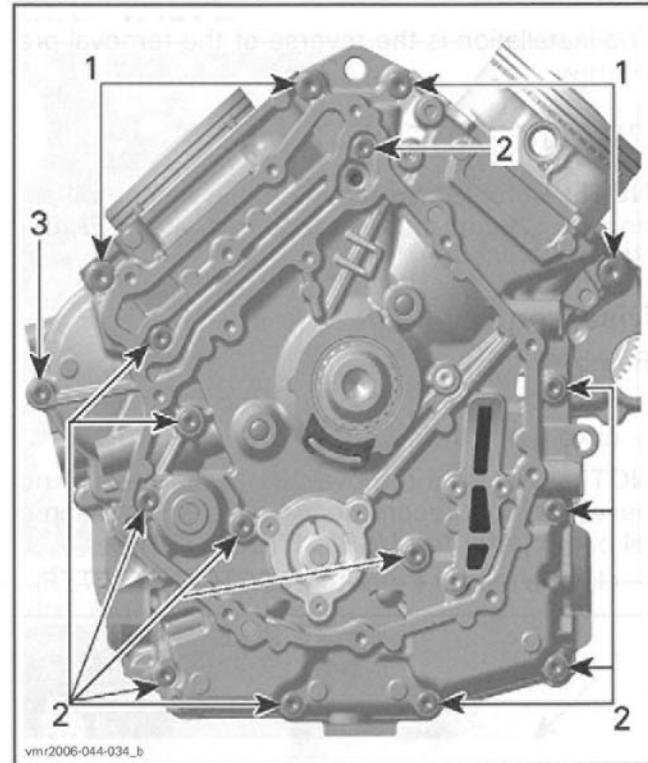

1. Four screws M8 x 65
2. 12 screws M6 x 75
3. One screw M6 x 35

Carefully split crankcase halves by using a screwdriver and a soft hammer.

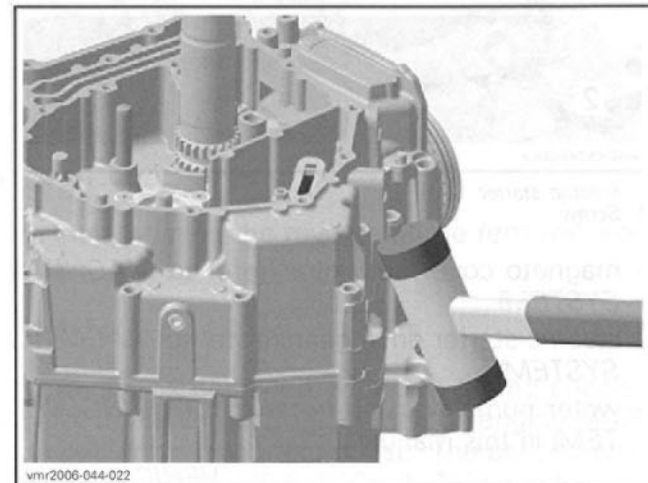

NOTE: During disassembly, do not damage the sealing surfaces of the crankcase halves.

Pull crankshaft out of crankcase.

Remove the water pump intermediate shaft and the water pump gear.

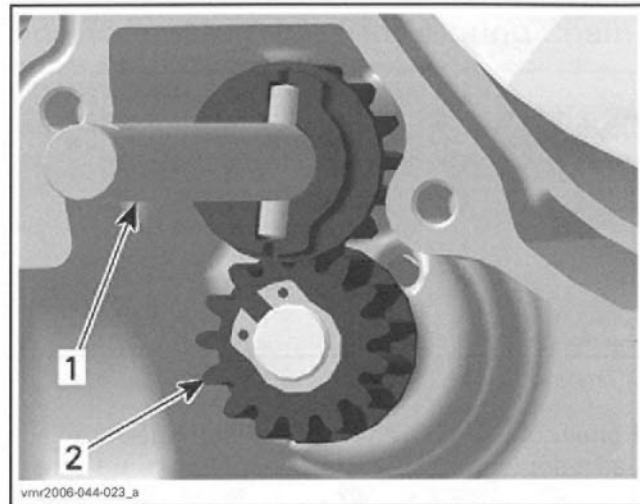

1. Water pump intermediate shaft
2. Water pump gear

Remove engine oil strainer.

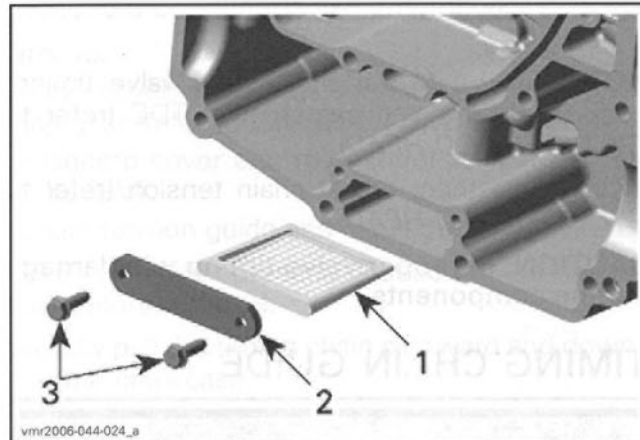

1. Engine oil strainer
2. Retaining plate
3. Screws

Inspection

NOTE: Remove all remaining parts from the crankcase halves; they could get damaged during repair work.

Clean crankcase halves from contaminations and blow the oil supply lines with compressed air.

WARNING
Use safety goggles to avoid eye injuries.

Check crankcase halves for cracks or other damage. Replace if damaged.

Check plain bearings no. 9 and no. 10 for scorings or other damages.

Section 01 V-810 ENGINE
Subsection 06 (BOTTOM END)

NOTE: Measure plain bearing inside diameter and compare to PTO/MAG side journal diameters of crankshaft (refer to *CRANKSHAFT* below). Replace if the measurements are out of specification.

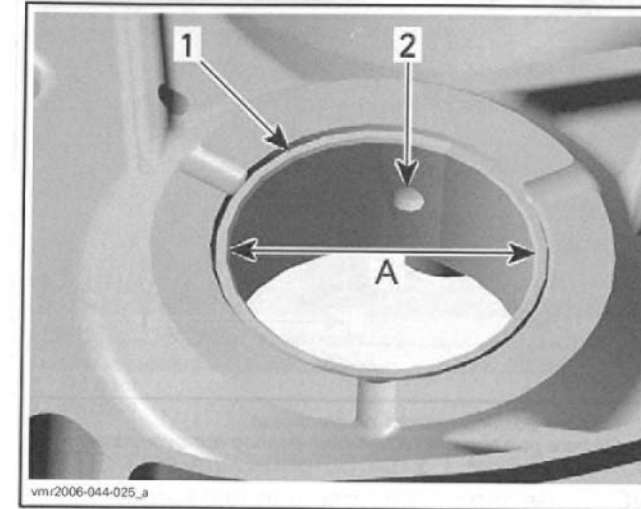

1. Plain bearing
2. Oil bore
- A. Measure plain bearing inside diameter

PLAIN BEARING INSIDE DIAMETER (PTO/MAG)	
SERVICE LIMIT	42.070 mm (1.6563 in)

Parts Replacement

Bearing Removal Procedure

CAUTION: Always support crankcase halves properly when ball bearings or plain bearings are removed. Damages to crankcase halves may occur if this procedure is not performed correctly.

NOTE: Always use a press for removal of plain bearings.

Remove plain bearings no. 9 and no. 10 with the proper plain bearing remover/installer (P/N 529 035 917).

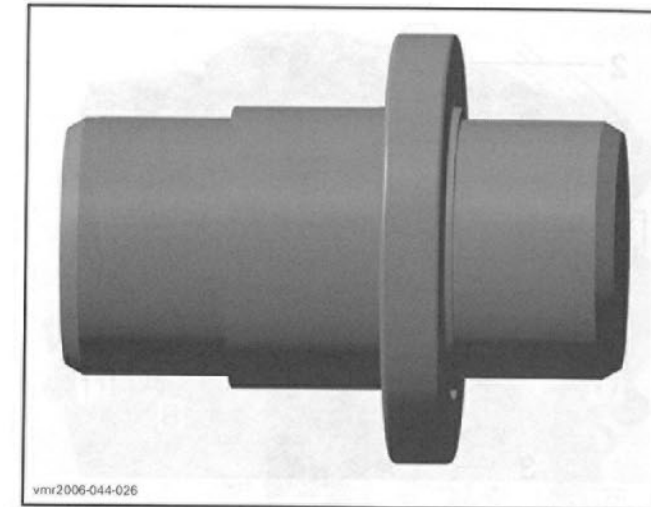

PLAIN BEARING REMOVER/INSTALLER (P/N 529 035 917)

Carefully push the plain bearings out, from the crankcase half inside towards the outside.

NOTE: Place the proper crankcase support sleeve (P/N 529 036 031) under crankcase halves before removing plain bearings.

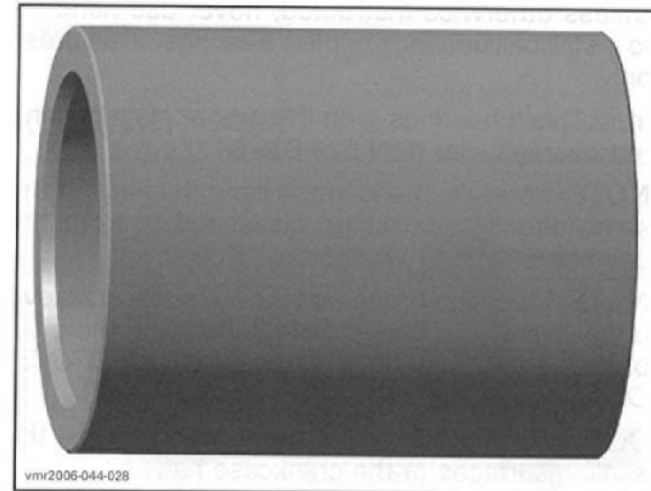

CRANKCASE SUPPORT SLEEVE (P/N 529 036 031)

NOTE: During disassembly, make sure not to damage the sealing surfaces of the crankcase halves.

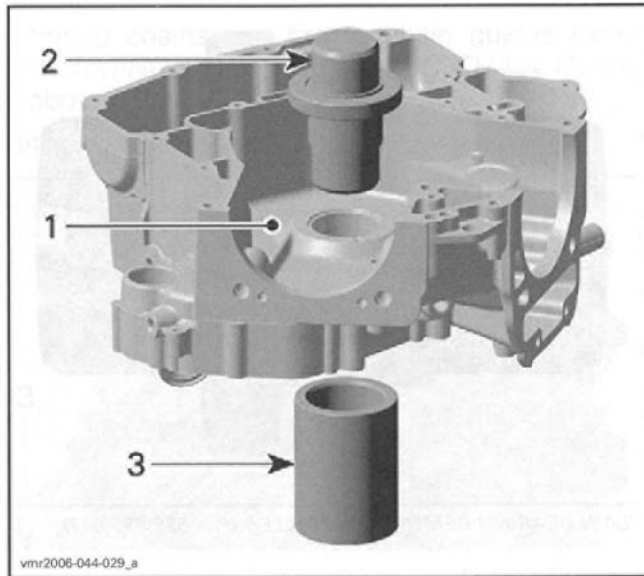

PUSH PLAIN BEARINGS OUTSIDE

1. Crankcase half
2. Plain bearing remover/installer
3. Crankcase support sleeve (P/N 529 036 031)

Bearing Installation Procedure

Unless otherwise instructed, never use hammer to install ball bearings or plain bearings. Use press only.

Install plain bearings with the proper plain bearing remover/installer (P/N 529 035 917).

NOTE: Carefully press-in the plain bearings in the same direction as during disassembly, from the crankcase inside towards the outside.

NOTE: Place the proper crankcase support sleeve under crankcase halves before installing the plain bearings (refer to *BEARING REMOVAL PROCEDURE* above).

During reassembly, make sure not to damage the sealing surfaces of the crankcase halves.

CAUTION: Mark position of oil bore on crankcase half and on plain bearing remover/installer. Align mark on plain bearing remover/installer with mark on crankcase half.

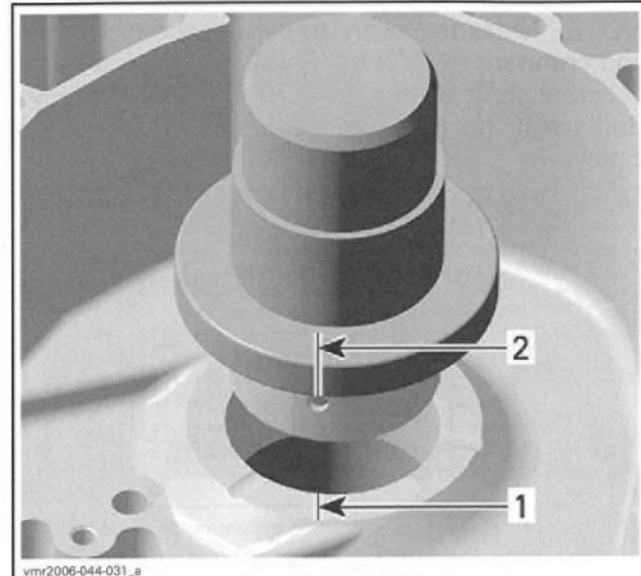

1. Oil bore position marked on crankcase
2. Oil bore position marked on plain bearing remover/installer

NOTE: Wrong oil bore position will stop oil supply to plain bearings and will cause engine damage.

CAUTION: The partition of the plain bearings in crankcase half MAG side must be positioned near to oil bore in clockwise direction (refer to no. 3 in next illustration).

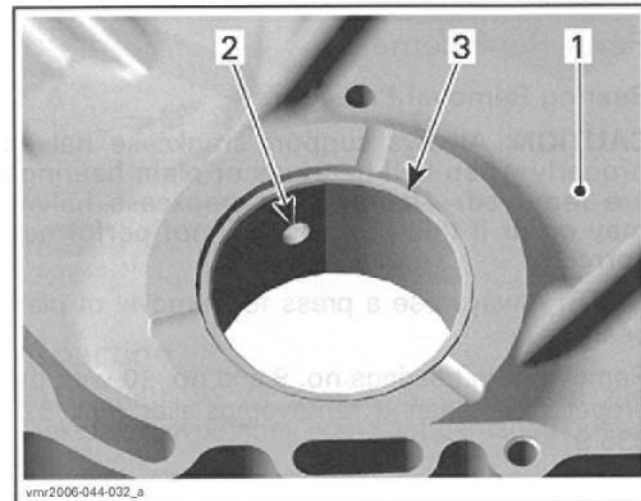

1. Crankcase half MAG (inside)
2. Oil bore
3. Partition

CAUTION: The partition of the plain bearings in crankcase half PTO side must be positioned near to oil bore in counterclockwise direction (refer to no. 3 in next illustration).

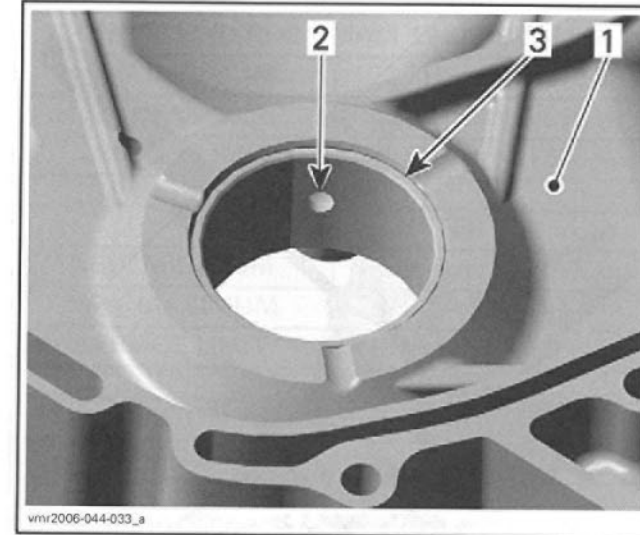

1. Crankcase half PTO (inside)
2. Oil bore
3. Partition

NOTE: Use an O-ring (Ø 42 x 1 to 1.5 mm (.04 to .06 in) thickness) to hold plain bearings in place during installation. The O-ring will disappear in the groove of the plain bearing remover/installer.

Assembly

The assembly of crankcase is essentially the reverse of removal procedure. However, pay attention to the following details.

NOTE: Clean oil passages and make sure they are not clogged.

Clean all metal components in a solvent.

NOTE: At installation, replace crankcase gasket.

Oil the plain bearings before mounting the crankshaft.

CAUTION: Correctly reinstall crankshaft (refer to *CRANKSHAFT* below).

Reinstall engine oil strainer (refer to *LUBRICATION SYSTEM* in this manual).

Reinstall water pump shaft shafts/gears (refer to *COOLING SYSTEM* in this manual).

Tightening sequence for screws on crankcase is as per following illustration.

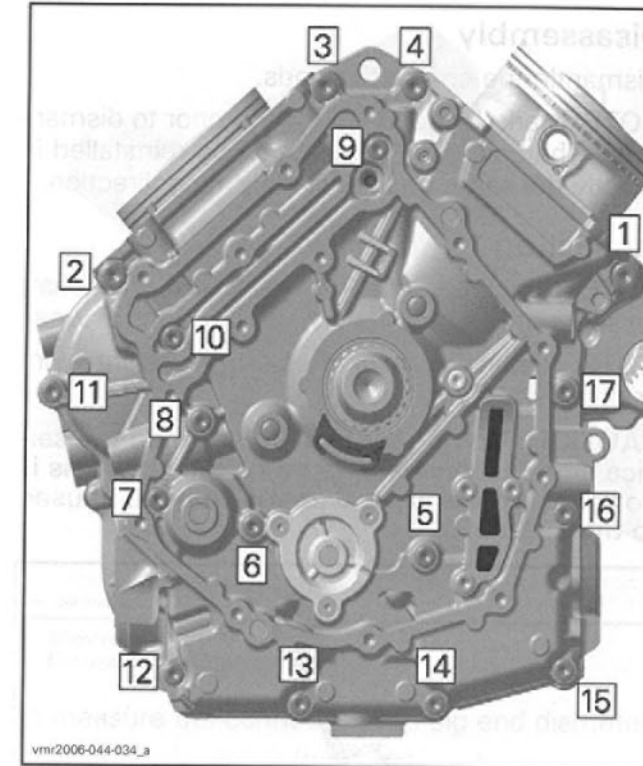

TIGHTENING SEQUENCE

CRANKSHAFT

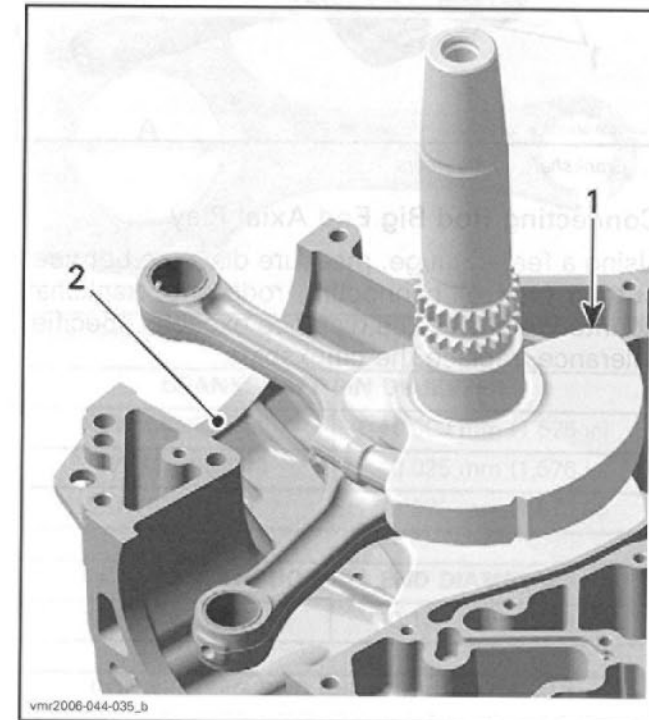

1. Crankshaft
2. Crankcase MAG

Removal

Refer to *CRANKCASE* above.

Section 01 V-810 ENGINE
Subsection 06 (BOTTOM END)

Disassembly

Dismantle the connecting rods.

NOTE: Mark the connecting rods prior to dismantling. The connecting rods must be reinstalled in exactly the same position and running direction.

Inspection

NOTE: Check each bearing journal of crankshaft for scoring, scuffing, cracks or other signs of wear.

NOTE: Replace crankshaft if the gears are worn or otherwise damaged.

CAUTION: Components with less than the service limit always have to be replaced. If this is not observed, severe damage may be caused to the engine.

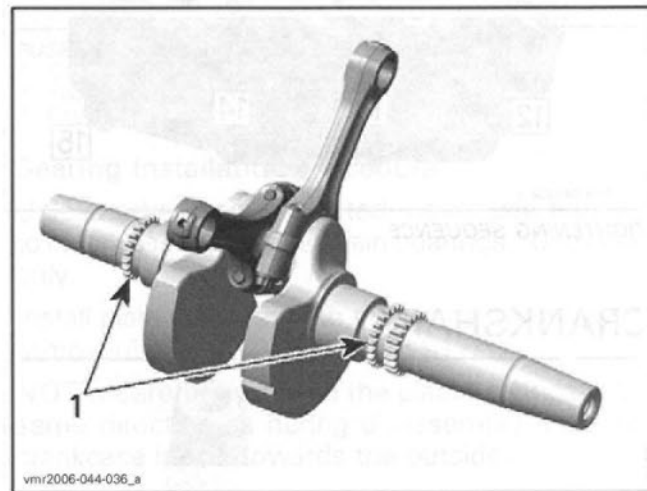

1. Crankshaft timing gears

Connecting Rod Big End Axial Play

Using a feeler gauge, measure distance between butting face of connecting rods and crankshaft counterweight. If the distance exceeds specified tolerance, replace the crankshaft.

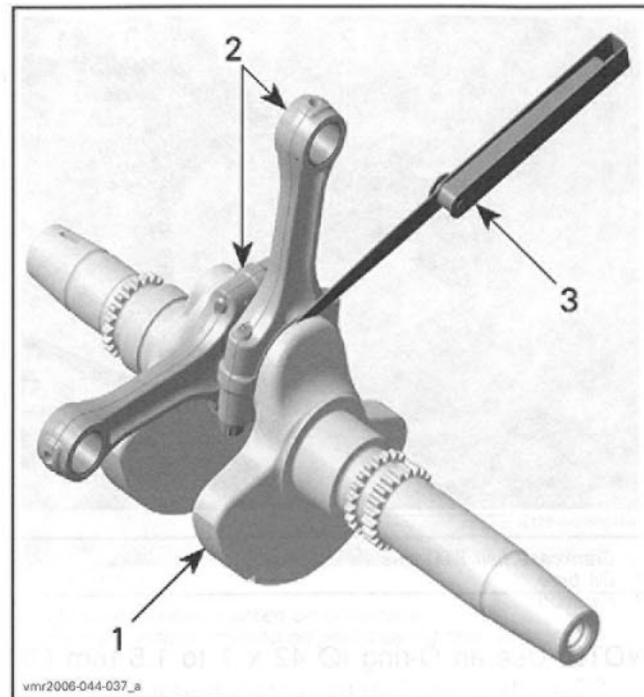

1. Crankshaft
2. Connecting rods
3. Feeler gauge

CONNECTING ROD BIG END	
NEW MINIMUM	0.200 mm (.008 in)
NEW MAXIMUM	0.500 mm (.020 in)
SERVICE LIMIT	0.6 mm (.024 in)

Connecting Rod/Piston Pin Clearance

Measure piston pin. Compare to inside diameter of connecting rod.

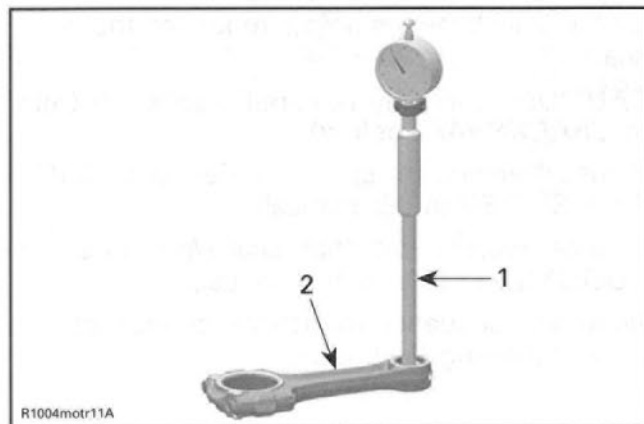

1. Bore gauge
2. Connecting rod



A. Piston pin diameter in the area of the bushing

Section 01 V-810 ENGINE
Subsection 06 (BOTTOM END)

CONNECTING ROD SMALL END DIAMETER	
NEW MINIMUM	20.010 mm (.7878 in)
NEW MAXIMUM	20.020 mm (.7882 in)
SERVICE LIMIT	20.060 mm (.7898 in)

PISTON PIN DIAMETER	
NEW MINIMUM	19.996 mm (.7872 in)
NEW MAXIMUM	20.000 mm (.7874 in)
SERVICE LIMIT	19.980 mm (.7866 in)

PISTON PIN BORE CLEARANCE	
SERVICE LIMIT	0.080 mm (.0035 in)

NOTE: If the connecting rod small end diameter is out of specification, replace connecting rod.

Connecting Rod Big End Radial Play

NOTE: Prior to remove connecting rod from the crankshaft, mark big end halves together to ensure a correct reinstallation (cracked surface fits in only one position).

Remove connecting rods from crankshaft.

CAUTION: Always replace connecting rod screws no. 11 if removing the connecting rod. It is recommended to replace plain bearings no. 12, in case of installing the connecting rod.

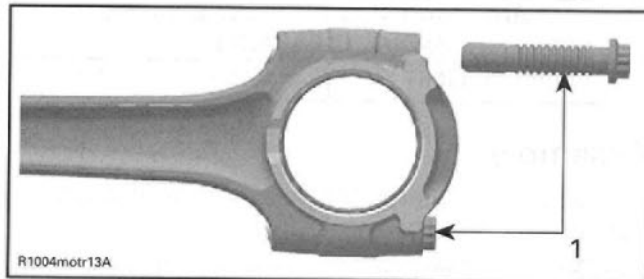

1. Connecting rod screw

Measure crankpin. Compare to inside diameter of connecting rod big end.

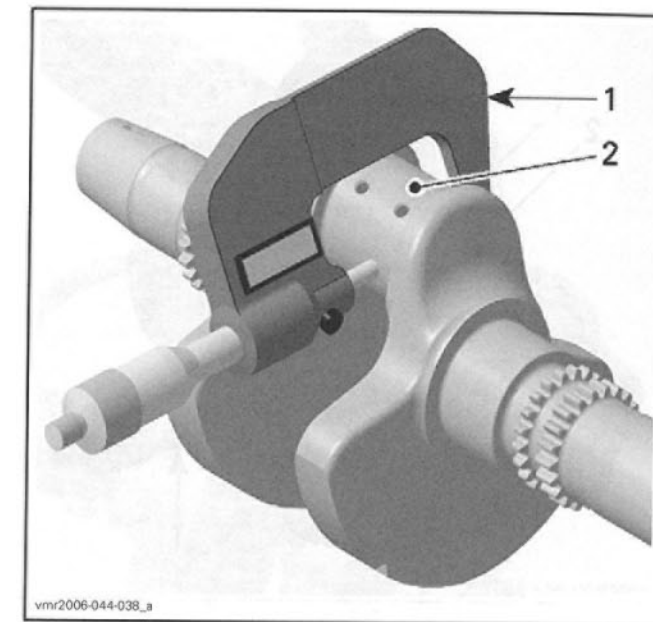

1. Micrometer
2. Crankpin area for plain bearing

To measure the connecting rod big end diameter, use the OLD screws no. 13.

Install the OLD plain bearings no. 12 as they were mounted initially.

Do the torque procedure as described further.

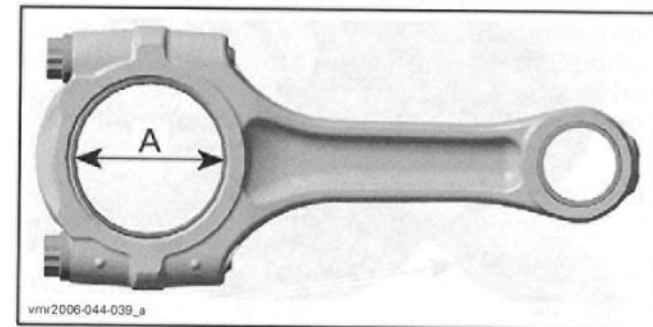

A. Connecting rod big end plain bearing

CRANKSHAFT PIN DIAMETER	
NEW MINIMUM	40.009 mm (1.575 in)
NEW MAXIMUM	40.025 mm (1.576 in)
SERVICE LIMIT	39.980 mm (1.574 in)

CONNECTING ROD BIG END DIAMETER	
SERVICE LIMIT	40.100 mm (1.579 in)

CONNECTING ROD BIG END CLEARANCE	
SERVICE LIMIT	0.09 mm (.0035 in)

Crankshaft Radial Play MAG/PTO Side

Measure crankshaft on MAG/PTO side. Compare to inside diameter of MAG/PTO plain bearing (refer to CRANKCASE).

Section 01 V-810 ENGINE
Subsection 06 (BOTTOM END)

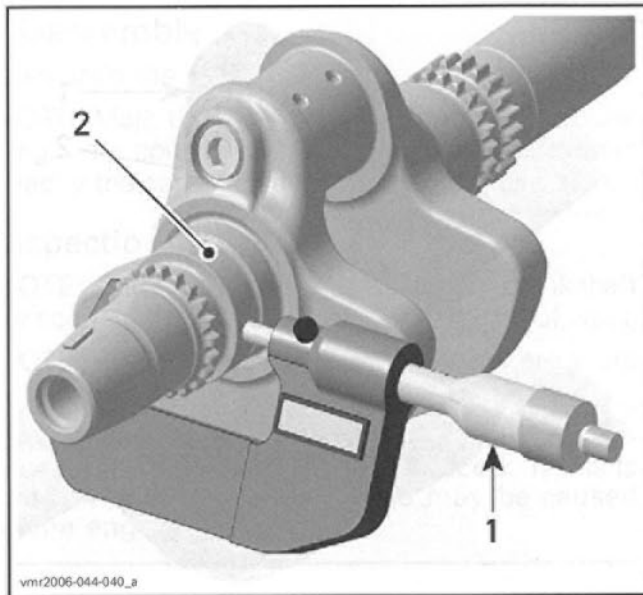

1. Micrometer
2. Crankshaft area for MAG plain bearing

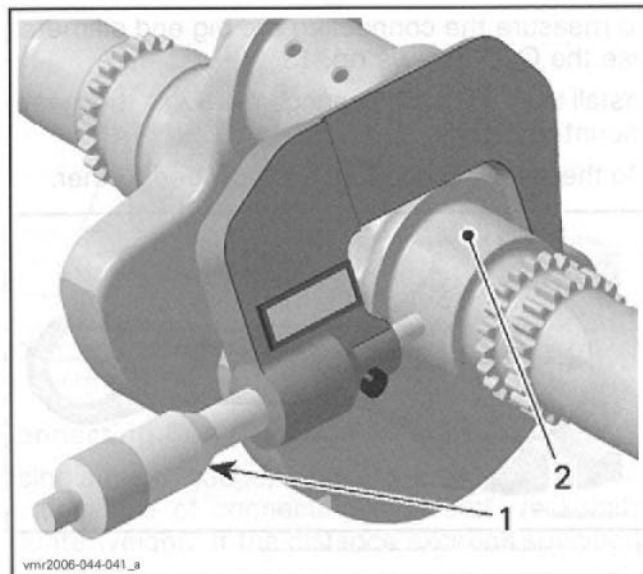

1. Micrometer
2. Crankshaft area for PTO plain bearing

CRANKSHAFT MAG/PTO SIDE DIAMETER	
NEW MINIMUM	42.024 mm (1.6545 in)
NEW MAXIMUM	42.040 mm (1.6551 in)
SERVICE LIMIT	42.000 mm (1.6535 in)

CRANKSHAFT MAG/PTO SIDE RADIAL CLEARANCE	
SERVICE LIMIT	0.07 mm (.0031 in)

Crankshaft Radial Play (PTO side support bearing)

Measure crankshaft journal of PTO support bearing. Compare to inside diameter of PTO support bearing in PTO cover (refer to *PTO COVER* at the beginning of this section).

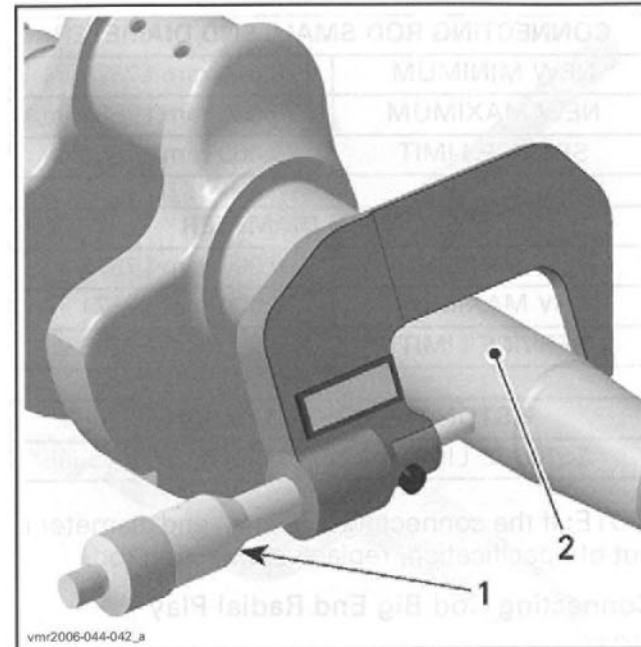

1. Micrometer
2. Crankshaft journal (PTO support bearing)

CRANKSHAFT JOURNAL DIAMETER (PTO support bearing)	
NEW MINIMUM	34.000 mm (1.3386 in)
NEW MAXIMUM	34.016 mm (1.3392 in)
SERVICE LIMIT	33.980 mm (1.3378 in)

CRANKSHAFT PTO SUPPORT BEARING RADIAL CLEARANCE	
SERVICE LIMIT	0.10 mm (.0039 in)

Assembly

For assembly, reverse the disassembly procedure. Pay attention to following details.

NOTE: Use NEW plain bearings no. 12, when connecting rod big end diameter is out of specification.

Put plain bearings correctly in place and clean the split surface on both sides (cracked area) carefully.

Section 01 V-810 ENGINE
Subsection 06 (BOTTOM END)

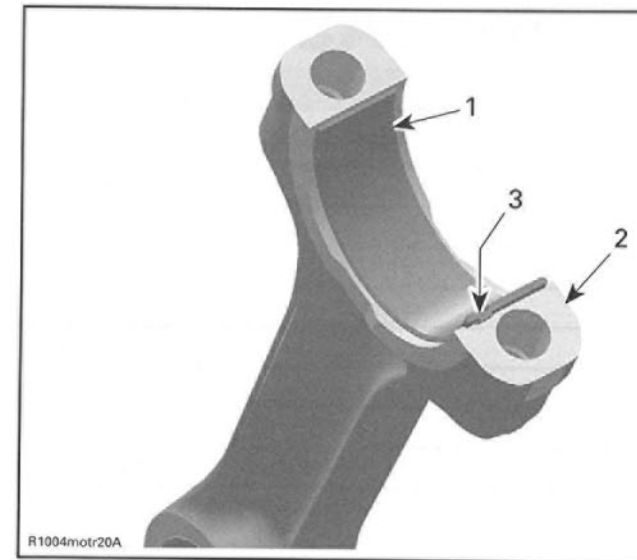

1. Half plain bearing of connecting rod big end
2. Split surface of the connecting rod
3. Nose of plain bearing in line with connecting rod groove

NOTE: Oil the plain bearings of the connecting rod before installation.

Torque NEW connecting rod screws no. 11 as per following procedure:

- Install screws with half of the recommended torque. Do not apply any thread locker.
- Torque connecting rod screws to 20 N•m (15 lbf•ft).
- Finish tightening the screws with an additional 60° turn using an angle torque wrench.

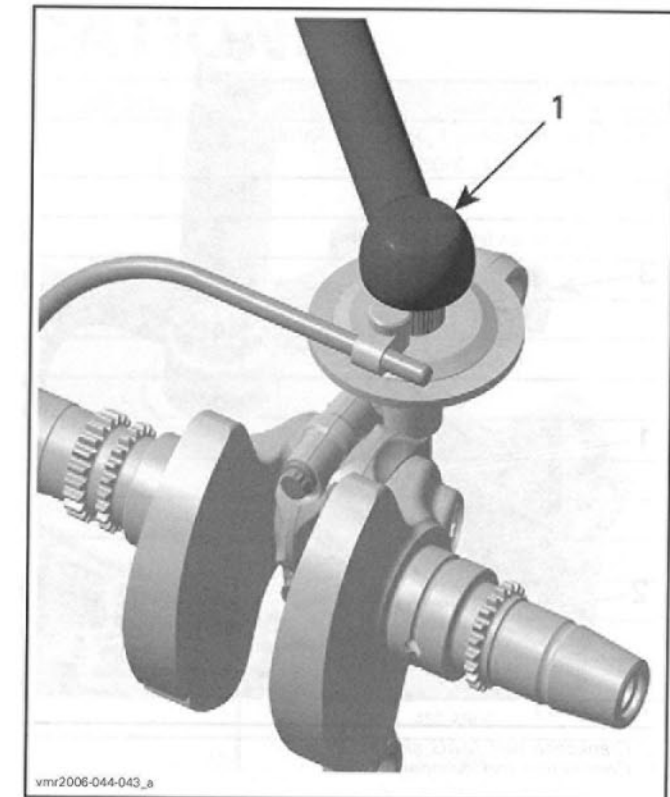

1. Angle torque wrench

CAUTION: Failure to strictly follow this procedure may cause screw to loosen and lead to engine damage. The plain bearing tapered end must be against the counterweight. Besides, as the "crankpin" screw has been stretched from the previous installation, it is very important to **use a new screw at assembly**.

NOTE: The running direction of the big end bearings and of the piston pins must not change.

Installation

For installation of crankshaft in crankcase reverse the removal procedure. Pay attention to the following details.

Do not mix up the connecting rods of cylinders 1 and 2 during installation.

CAUTION: Observe the correct installation position when fitting the crankshaft with the connecting rods. The connecting rod MAG side has to face to cylinder 1.

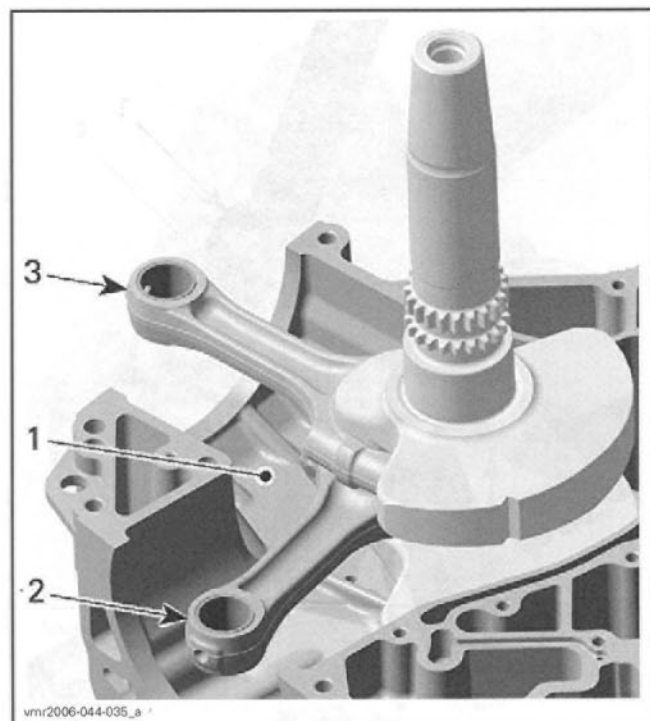

1. Crankcase half MAG side
2. Connecting rod cylinder 1
3. Connecting rod cylinder 2

CAUTION: Install CRANKSHAFT LOCKING BOLT to put crankshaft in TDC position before installing the camshaft and rocker arms (refer to *CRANKSHAFT LOCKING PROCEDURE* in *CYLINDER AND CYLINDER HEAD* section).

TECHNICAL SPECIFICATIONS

ENGINE			
Engine type	ROTAX V-810 4-TEC, 4-stroke, Single Over Head Camshaft (SOHC), liquid cooled		
Number of cylinders	2		
Number of valves	8 valves (mechanical adjustment)		
Bore	Standard	91 mm (3.58 in)	
Stroke	61.5 mm (2.42 in)		
Displacement	800 cm ³ (48.82 in ³)		
Compression ratio	10.3:1		
Decompressor type	N.A.		
Maximum HP RPM	6750 RPM		
Lubrication	Type	Wet sump. Replaceable oil filter	
	Oil type	Refer to the appropriate <i>VEHICLE SHOP MANUAL</i>	
Engine oil pressure	Minimum	350 kPa (51 PSI) at 6000 RPM	
Oil filter	BRP Rotax paper type, replaceable		
Intake valve opening	10° BTDC		
Intake valve closing	45° ABDC		
Exhaust valve opening	50° BBDC		
Exhaust valve closing	0° ATDC		
Valve clearance	Intake	0.06 mm (.0024 in) to 0.14 mm (.0055 in)	
	Exhaust	0.11 mm (.0043 in) to 0.19 mm (.0075 in)	
Valve stem diameter	Intake	Minimum New	4.966 mm (.1955 in)
		Maximum New	4.980 mm (.1960 in)
		Service limit	4.930 mm (.1941 in)
	Exhaust	Minimum New	4.956 mm (.1951 in)
		Maximum New	4.970 mm (.1957 in)
		Service limit	4.930 mm (.1941 in)
Valve guide diameter	Minimum New	5.006 mm (.1971 in)	
	Maximum New	5.018 mm (.1976 in)	
	Service limit	5.050 mm (.1988 in)	
Valve spring free length	Nominal New	40.81 mm (1.607 in)	
	Service limit	39.00 mm (1.535 in)	
Valve seat contact width	Intake	Minimum New	1.05 mm (.041 in)
		Maximum New	1.35 mm (.053 in)
		Service limit	1.8 mm (.070 in)
	Exhaust	Minimum New	1.25 mm (.049 in)
		Maximum New	1.55 mm (.061 in)
		Service limit	2 mm (.078 in)
Rocker arm bore diameter	Minimum New	12.036 mm (.4739 in)	
	Maximum New	12.050 mm (.4744 in)	
	Service limit	12.060 mm (.4748 in)	
Rocker arm shaft diameter	Minimum New	12.000 mm (.4724 in)	
	Maximum New	12.018 mm (.4731 in)	
	Service limit	11.990 mm (.4720 in)	

Section 01 V-810 ENGINE
Subsection 07 (TECHNICAL SPECIFICATIONS)

ENGINE			
Piston measurement	Nominal New	90.950 to 90.966 mm (3.5807 to 3.5813 in)	
Piston/cylinder clearance	Minimum New	0.027 mm (.0011 in)	
	Maximum New	0.057 mm (.0022 in)	
	Service limit	0.100 mm (.0040 in)	
Piston ring type	1 st	Upper compression ring, rectangular	
	2 nd	Lower compression ring, tapered face	
	3 rd	Oil scraper ring	
Ring end gap	Rectangular	Minimum New	0.20 mm (.008 in)
	Taper-face		0.20 mm (.008 in)
	Oil scraper ring		0.20 mm (.008 in)
	Rectangular	Maximum New	0.40 mm (.016 in)
	Taper-face		0.40 mm (.016 in)
	Oil scraper ring		0.70 mm (.028 in)
All	Service limit	1.5 mm (.059 in)	
Ring/piston groove clearance	Rectangular	Minimum New	0.03 mm (.0012 in)
	Taper-face		0.02 mm (.0008 in)
	Oil scraper ring		0.01 mm (.0004 in)
	Rectangular	Maximum New	0.070 mm (.0028 in)
	Taper-face		0.060 mm (.0024 in)
	Oil scraper ring		0.045 mm (.0018 in)
All	Service limit	0.15 mm (.0059 in)	
Cylinder bore	Nominal New	90.993 to 91.007 mm (3.5823 to 3.5829 in)	
Cylinder taper	Maximum New	0.038 mm (.0015 in)	
	Service limit	0.090 mm (.0035 in)	
Cylinder out of round	Maximum New	0.015 mm (.0006 in)	
	Service limit	0.020 mm (.0008 in)	
Camshaft bearing journal	Timing chain side	Minimum New	34.959 mm (1.3763 in)
		Maximum New	34.975 mm (1.3770 in)
		Service limit	34.950 mm (1.3760 in)
	Spark plug side	Minimum New	21.959 mm (.8645 in)
		Maximum New	21.980 mm (.8654 in)
		Service limit	21.950 mm (.8642 in)
Camshaft bore	Timing chain side	Minimum New	35.000 mm (1.3780 in)
		Maximum New	35.025 mm (1.3789 in)
		Service limit	35.040 mm (1.3795 in)
	Spark plug side	Minimum New	22.000 mm (.8661 in)
		Maximum New	22.021 mm (.8670 in)
		Wear limit	22.040 mm (.8677 in)
Camshaft lobe	Intake valve	Minimum New	32.11 mm (1.2642 in)
		Maximum New	32.31 mm (1.2721 in)
		Service limit	32.09 mm (1.2634 in)
	Exhaust valve	Minimum New	31.94 mm (1.2575 in)
		Maximum New	32.14 mm (1.2654 in)
		Service limit	31.92 mm (1.2567 in)

Section 01 V-810 ENGINE
Subsection 07 (TECHNICAL SPECIFICATIONS)

ENGINE			
Crankshaft journal diameter MAG/PTO side	Minimum New	42.024 mm (1.6545 in)	
	Maximum New	42.040 mm (1.6551 in)	
	Service limit	42.000 mm (1.6535 in)	
Crankshaft radial clearance MAG/PTO side	Service limit	0.07 mm (.0031 in)	
Crankshaft journal diameter PTO support bearing	Minimum New	34.000 mm (1.3386 in)	
	Maximum New	34.016 mm (1.3392 in)	
	Service limit	33.980 mm (1.3378 in)	
Crankshaft radial clearance PTO support bearing	Service limit	0.10 mm (.0039 in)	
Crankshaft pin diameter	Minimum New	40.009 mm (1.575 in)	
	Maximum New	40.025 mm (1.576 in)	
	Service limit	39.980 mm (1.574 in)	
Crankshaft deflection	MAG side	Nominal New	0.050 mm (.002 in)
	PTO side	Nominal New	0.050 mm (.002 in)
Crankshaft radial clearance	MAG side	Service limit	0.07 mm (.0031 in)
	PTO side	Service limit	0.07 mm (.0031 in)
Crankcase plain bearing	MAG side	Service limit	42.070 mm (1.6563 in)
	PTO side	Service limit	42.070 mm (1.6563 in)
PTO cover plain bearing	Service limit	34.080 mm (1.3417 in)	
Connecting rod big end diameter	Service limit	40.100 mm (1.579 in)	
Connecting rod big end clearance	Minimum New	0.200 mm (.008 in)	
	Maximum New	0.500 mm (.020 in)	
	Service limit	0.600 mm (.024 in)	
Connecting rod small end diameter	Minimum New	20.010 mm (.7878 in)	
	Maximum New	20.020 mm (.7882 in)	
	Service limit	20.060 mm (.7898 in)	
Piston pin diameter	Minimum New	19.996 mm (.7872 in)	
	Maximum New	20.000 mm (.7874 in)	
	Service limit	19.980 mm (.7866 in)	
Piston pin bore clearance	Service limit	0.080 mm (.0035 in)	
ELECTRICAL			
Magneto generator output		420 W @ 6000 RPM	
Ignition system type		DI (Digital Induction)	
Ignition timing		Not adjustable	
Spark plug	Quantity	2	
	Make and type	NGK DCP8E	
	Gap	0.7 - 0.8 mm (.028 to .032 in)	
Engine RPM limiter setting	Forward	8000 RPM	
	Reverse	3200 RPM	

Section 01 V-810 ENGINE

Subsection 07 (TECHNICAL SPECIFICATIONS)

COOLING	
Type	Liquid cooled. Closed loop for engine
Coolant	Ethylene-glycol 50%/50% antifreeze/water. Coolant containing corrosion inhibitors for internal combustion aluminum engines
Thermostat	Opening temperature 65°C (149°F)
CAPACITIES	
Engine oil	Refer to the appropriate <i>VEHICLE SHOP MANUAL</i>
Cooling system (coolant)	