

# REAR DRIVE SYSTEM AND SUSPENSION SYSTÈME D'ENTRAÎNEMENT ARRIÈRE ET SUSPENSION

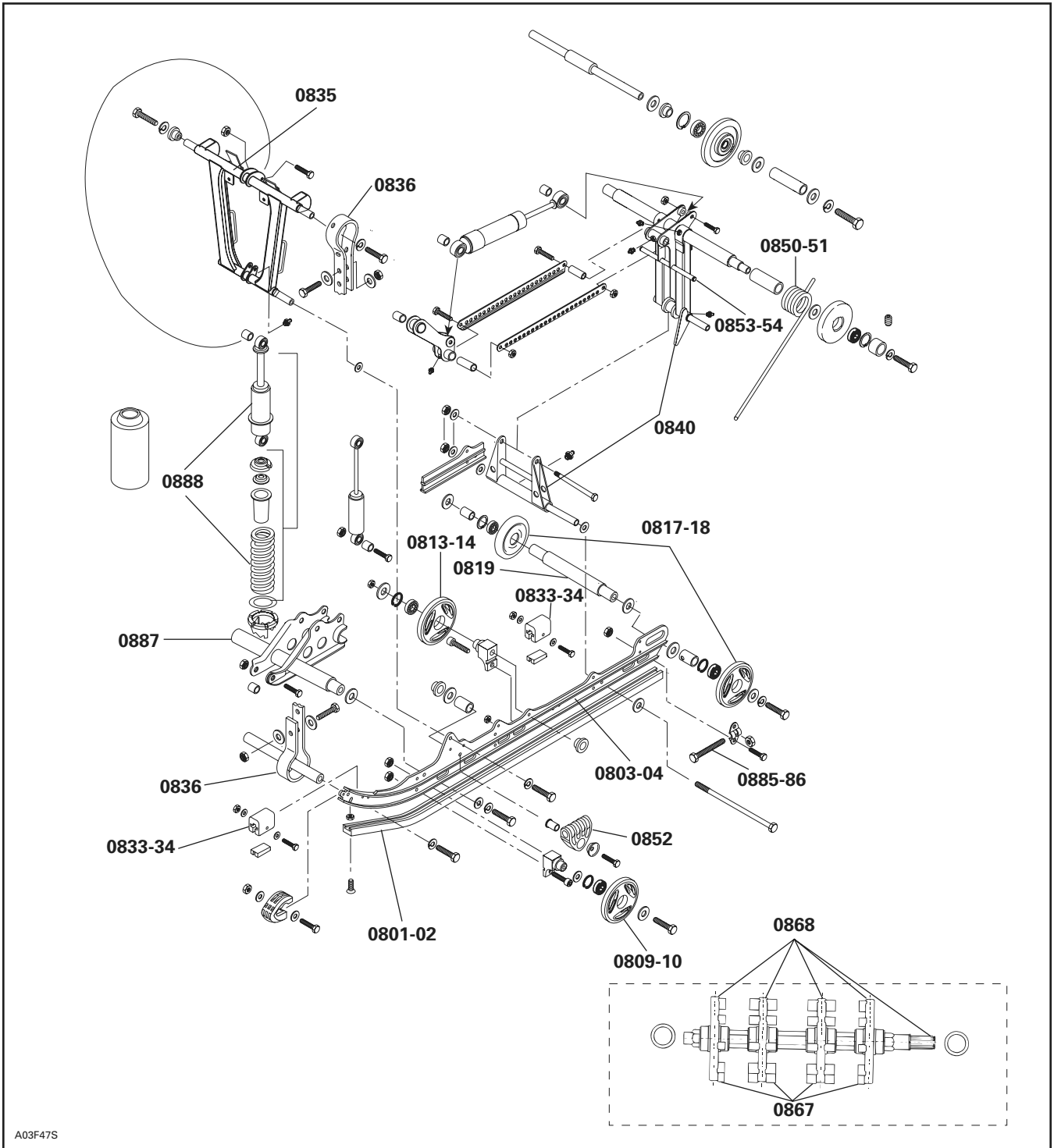

A03F47S

SYSTEM SYSTÈME	CODE	DESCRIPTION	MX Z/GSX 500 SS	GTX 500 SS	SKANDIC 600 SUV/WT	MX Z/GSX 600 HO SDI	MX Z 600 RS	GTX 600 HO SDI	EXPEDITION/ SKANDIC 600 HO SDI	SUMMIT 600 HO SDI
			11	12	13	14	15	16	17	18
09	00	<b>NO LABOR INVOLVED AUCUNE MAIN-D'OEUVRE IMPLIQUÉE</b>	0	0	0	0	0	0	0	0
09	01	HOOD CAPOT	0.3	0.9	2.0	0.3	0.3	0.9	2.0	0.9
09	03	HOOD HINGE CHARNIÈRE DU CAPOT		0.3	0.3			0.3	0.3	0.3
09	05	CAB DECALS (RH OR LH) AUTOCOLLANTS DE LA CABINE (DROIT OU GAUCHE)	0.3	0.3	0.3	0.3	0.3	0.3	0.3	0.3
09	06	CAB DECALS (ALL) AUTOCOLLANTS DE LA CABINE (TOUS)	0.5	0.9	0.9	0.5	0.5	0.9	0.9	0.9
09	07	CAB LATCH (1 OR 2) ATTACHE DE LA CABINE (1 OU 2)		0.3	0.3			0.3	0.3	0.3
09	09	WINDSHIELD PARE-BRISE	0.3	0.3	0.3	0.3	0.3	0.3	0.3	0.3
09	13	CARGO RACK SUPPORT À BAGAGES			0.4			0.4	0.4	
09	14	FRONT BUMPER PARE-CHOCS AVANT	0.4	0.3	0.6	0.4	0.4	0.3	0.6	0.3
09	16	FRONT BUMPER CAP (RH OR LH) EXTRÉMITÉ DU PARE-CHOCS AVANT (DROIT OU GAUCHE)			0.3					
09	17	CONSOLE CONSOLE	0.3	0.6	1.2	0.3	0.3	0.6	1.2	0.6
09	21	SEAT (ASS'Y) OR BACKREST SIÈGE (COMPLET) OU DOSSIER	0.3	0.3	0.3	0.3	0.3	0.3	0.3	0.3
09	22	SEAT COVER AND/OR FOAM HOUSSE DE SIÈGE ET/OU MOUSSE	0.5	1.1	1.2	0.5	0.5	1.1	1.1	1.1
09	23	SEAT FOAM MOUSSE DE SIÈGE	0.5	1.1	1.2	0.5	0.5	1.1	1.1	1.1
09	24	BOTTOM PAN COQUE			2.0					
09	28	FRONT FASCIA FACIA AVANT	0.3			0.3	0.3			
09	30	REAR FOOTREST REPOSE-PIED ARRIÈRE		0.3	0.3			0.3	0.3	
09	31	FRONT RADIATOR RADIATEUR AVANT	3.0			3.0	3.0			
09	33	RADIATOR RADIATEUR	4.3	3.9	3.6	4.3	4.3	3.9	3.6	3.9
09	34	REAR BUMPER PARE-CHOCS ARRIÈRE	0.3	0.3	0.3	0.3	0.3	0.3	0.3	0.3
09	35	HITCH SUPPORT (ALL PARTS) SUPPORT D'ATTELAGE (TOUTES PIÈCES)			0.3				0.3	
09	40	BUMPER DECALS OR MOULDING AUTOCOLLANTS OU MOULURE DES PARE-CHOCS			0.3				0.3	

# BODY AND ACCESSORIS CARROSSERIE ET ACCESSOIRES

# 09

SYSTEM/SYSTEME

SYSTEM SYSTEME	CODE	DESCRIPTION	MX Z/GSX 500 SS	GTX 500 SS	SKANDIC 600 SUV/WT	MX Z/GSX 600 HO SDI	MX Z 600 RS	GTX 600 HO SDI	EXPEDITION/ SKANDIC 600 HO SDI	SUMMIT 600 HO SDI
			11	12	13	14	15	16	17	18
09	41	SUITCASE AND/OR SUPPORT VALISE ET/OU SUPPORT						0.3		
09*	49	<b>FRAME (ASS'Y) CHÂSSIS (COMPLET)</b>	<b>13.8</b>	<b>13.8</b>	<b>11.6</b>	<b>13.8</b>	<b>13.8</b>	<b>13.8</b>	<b>12.0</b>	<b>13.8</b>
09	51	REAR CAP FRAME CAPUCHON ARRIÈRE DU CHÂSSIS	0.7	0.7		0.7	0.7	0.7		0.7
09	55	SNOW GUARD (1) GARDE-NEIGE (1)	0.3	0.3	0.3	0.3	0.3	0.3	0.3	0.3
09	58	BACKREST AND/OR COVER DOSSIER ET/OU HOUSSE			0.3			0.3	0.3	
09	59	BACKREST ARM BRAS DU DOSSIER			0.3				0.3	
09	64	SEAT BELT COURROIE DE SIÈGE							0.3	
09	65	MIRROR (1) RÉTROVISEUR (1)	0.3	0.3	0.3		0.3	0.3	0.3	0.3
09	66	MIRRORS (2) RÉTROVISEURS (2)	0.3	0.3	0.3		0.3	0.3	0.3	0.3
09	68	HOOD GUIDE (RH OR LH) GUIDE DE CAPOT (DROIT OU GAUCHE)			0.3					
09	69	LOWER OR UPPER HOOD HINGE (1) CHARNIÈRE INFÉRIEURE OU SUPPORT DE CABINE (1)			0.6					
09	77	RH BOTTOM PAN COQUE CÔTÉ DROIT	0.7	0.7		0.7	0.7	0.7	1.7	0.7
09	78	LH BOTTOM PAN COQUE CÔTÉ GAUCHE	0.7	0.7		0.7	0.7	0.7	1.5	0.7
09	79	CENTER BOTTOM PAN COQUE PARTIE CENTRALE	0.8	0.5		0.8	0.8	0.5	0.7	0.5
09	80	FRONT GRILL (RH AND/OR LH) GRILLE AVANT (DROIT ET/OU GAUCHE)	0.3	0.3	0.8	0.8	0.3	0.3	0.3	0.3
09	81	SIDE GRIL (RH) GRILLE LATÉRALE (DROIT)	0.3	0.3	0.3	0.3	0.3	0.3	0.3	0.3
09	96	FOOT PROTECTOR (RH OR LH) PROTÈGE PIED (DROIT OU GAUCHE)	2.2			2.2	2.2			
09	108	REAR SEAT (1+1) SIÈGE ARRIÈRE (1+1)				0.3				
09	149	ENGINE SIDE PANELS (2) PANNEAUX MOTEUR (2)	0.9	0.9		0.9	0.9	0.9		0.9
09	156	FRONT FRAME CHÂSSIS AVANT	3.0	6.3		3.0	3.0	6.3		5.9
09	157	UPPER CONSOLE CONSOLE SUPÉRIEURE	0.3	0.3		0.3	0.3	0.3		0.3
09	163	MEMBER (RH OR LH) MEMBRURE (DROIT OU GAUCHE)	0.4	0.4		0.4	0.4	0.4		0.4
09	191	SIDE PANEL DECAL (RH OR LH) (1) DÉCALQUE DE PANNEAU (DROIT OU GAUCHE) (1)	0.3	0.3		0.3	0.3	0.3		0.3

SYSTEM SYSTÈME	CODE	DESCRIPTION	MX Z/GSX 500 SS	GTX 500 SS	SKANDIC 600 SUV/WT	MX Z/GSX 600 HO SDI	MX Z 600 RS	GTX 600 HO SDI	EXPEDITION/ SKANDIC 600 HO SDI	SUMMIT 600 HO SDI
			11	12	13	14	15	16	17	18
09	192	SIDE PANEL DECALS (RH OR LH) (ALL) DÉCALQUES DE PANNEAU (DROIT OU GAUCHE) (TOUS)	0.6	0.6		0.6	0.6	0.6		0.6
09	193	CENTRAL SEAT COVER AND/OR FOAM HOUSSE ET/OU MOUSSE SIÈGE CENTRAL						0.5		
09	194	ENGINE SIDE PANEL (RH OR LH) PANNEAU LATÉRAL DU MOTEUR (DROIT OU GAUCHE)	0.5	0.5		0.5	0.5	0.5		0.5
09	195	FRONT PLATE PLAQUE AVANT	3.7	6.5		3.7	3.7	6.6		6.3
09	196	REAR HANDLE AND/OR GRIP POIGNÉE ARRIÈRE ET/OU GAINÉ		0.5		0.3		0.5		
09	197	REAR HANDLES AND/OR GRIPS POIGNÉES ARRIÈRE ET/OU GAINES		0.9		0.4		0.9		
09	198	BACKREST PARTS PIÈCES DU DOSSIER		0.3		0.3		0.3		
09	199	REAR SEAT BASE AND/OR ALL PARTS BASE SIÈGE ARRIÈRE ET/OU TOUTES LES PIÈCES		1.9		0.4		1.9	1.0	
09	201	FRONT PLATE (FRONT FRAME) PLAQUE FRONTALE (CHÂSSIS AVANT)		3.2				3.2		3.2
09	203	REAR SEAT COVER OR FOAM HOUSSE OU MOUSSE DU SIÈGE ARRIÈRE				0.5		1.0	1.0	
09	238	LOWER SIDE PANEL (RH OR LH) PANNEAU LATÉRAL INFÉRIEUR (DROIT OU GAUCHE)	0.3			0.3	0.3			
09	243	DEFLECTOR PANEL (RH OR LH) PANNEAU DÉFLECTEUR (DROIT OU GAUCHE)	0.3			0.3	0.3			
09	249	WINDSHIELD SUPPORT SUPPORT DE PARE-BRISE	0.3			0.3	0.3			
09	250	AIR DEFLECTOR (RH OR LH) DÉFLECTEUR D'AIR (DROIT OU GAUCHE)	0.3			0.3	0.3			
09	251	PANEL LATCH (ALL) LOQUET DE PANNEAU (TOUS)	0.3			0.3	0.3			
09	252	FOOTREST REINFORCEMENT (RH OR LH) RENFORT DE MARCHE-PIED (DROIT OU GAUCHE)	1.1			1.1	1.1			

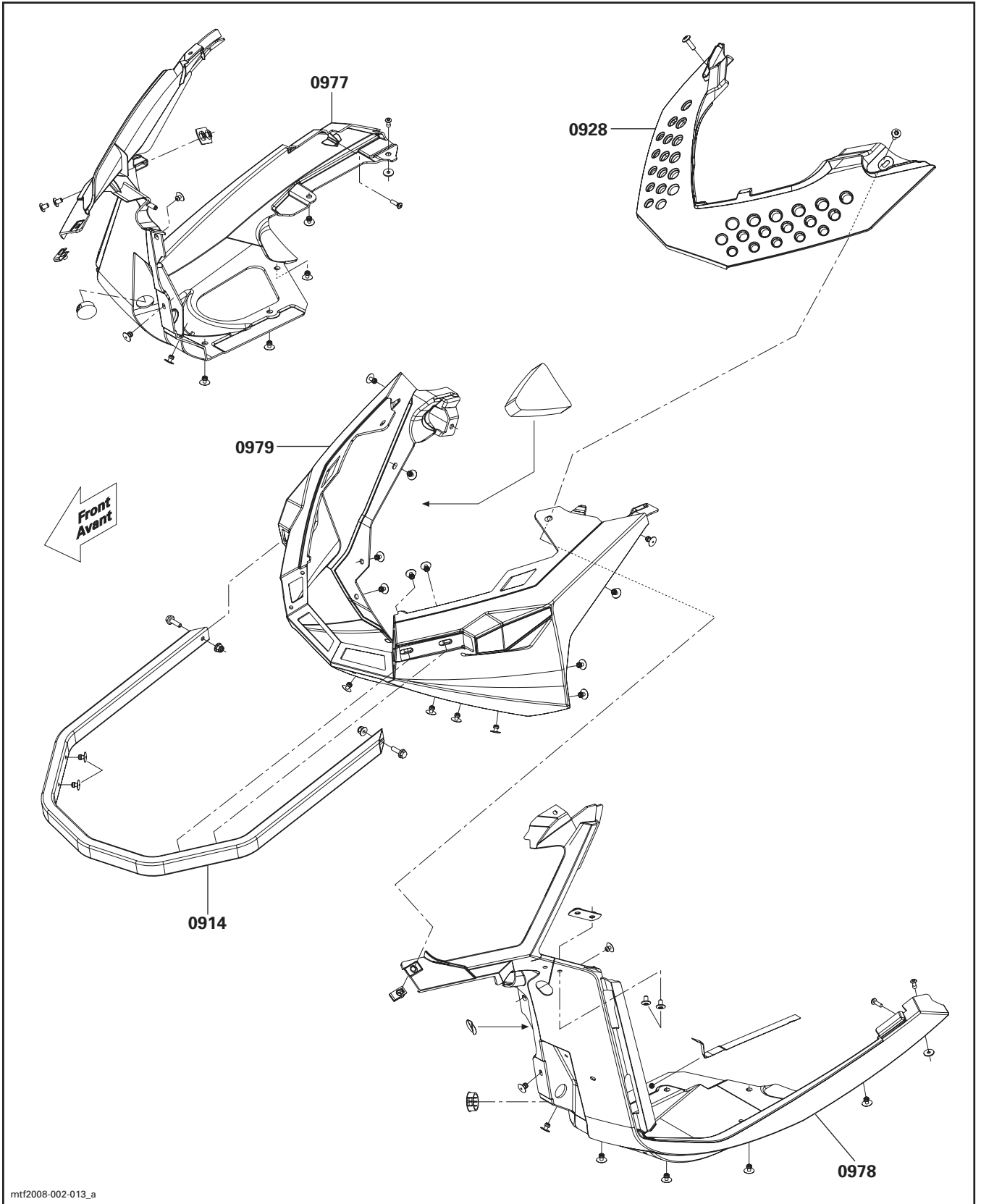

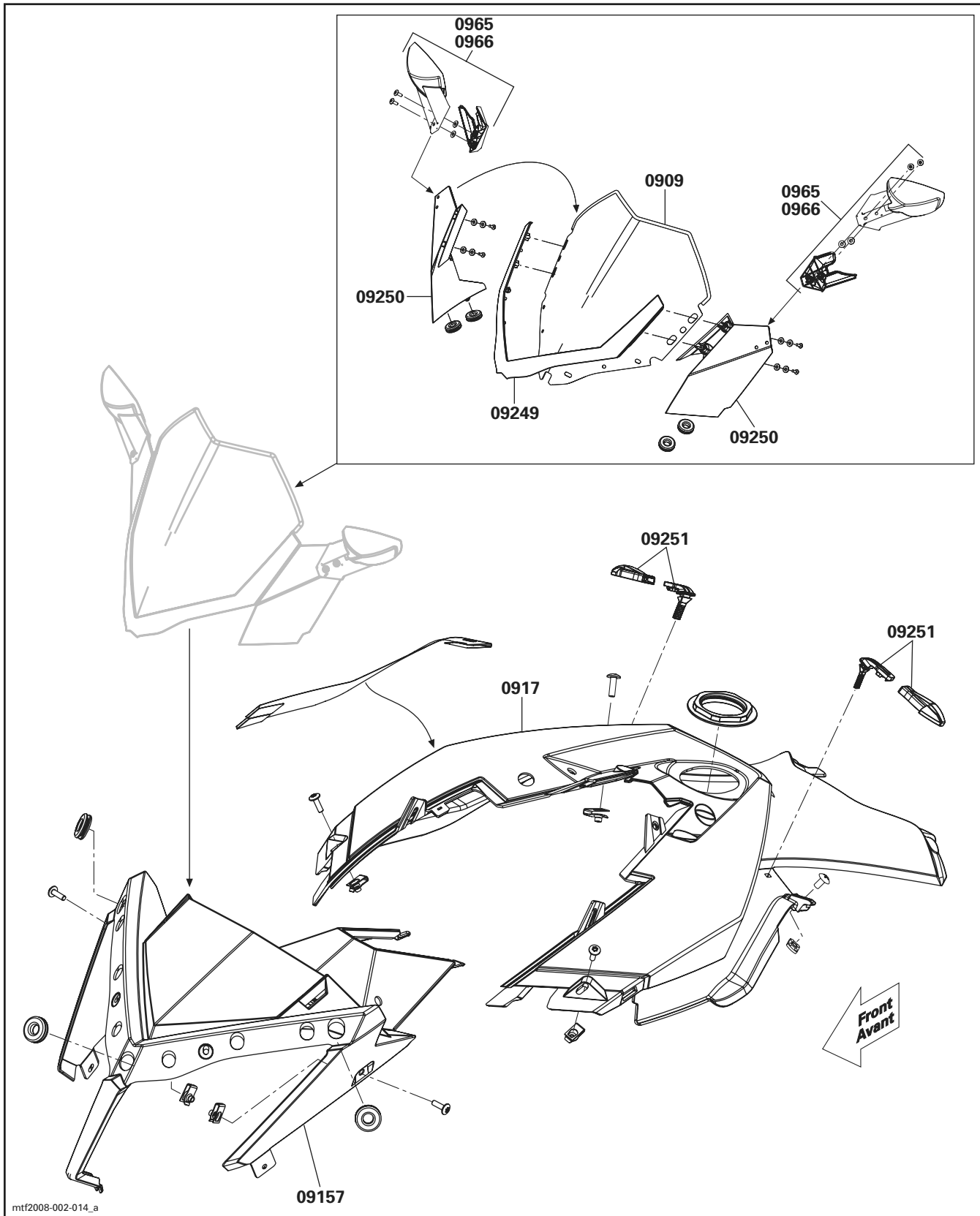

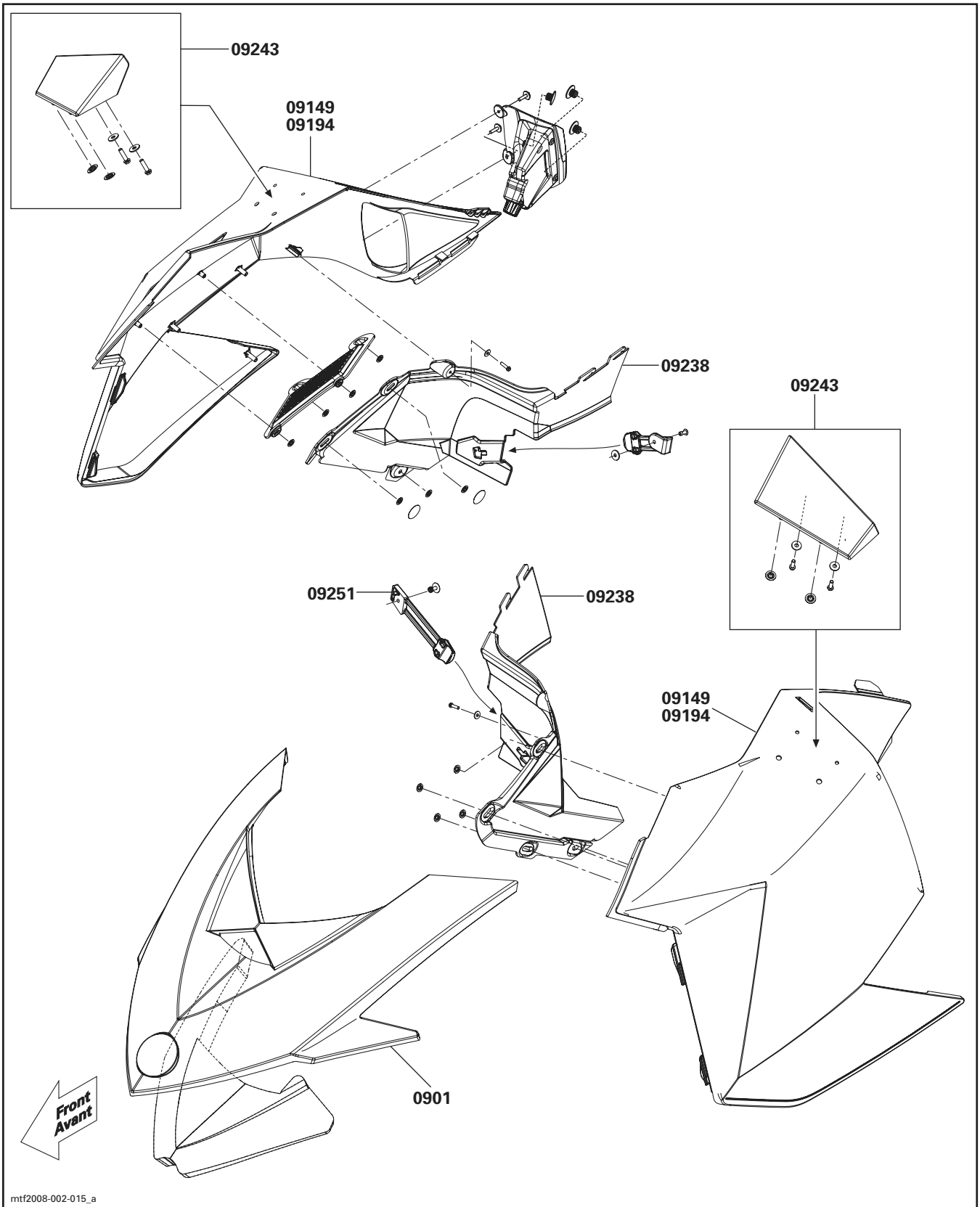

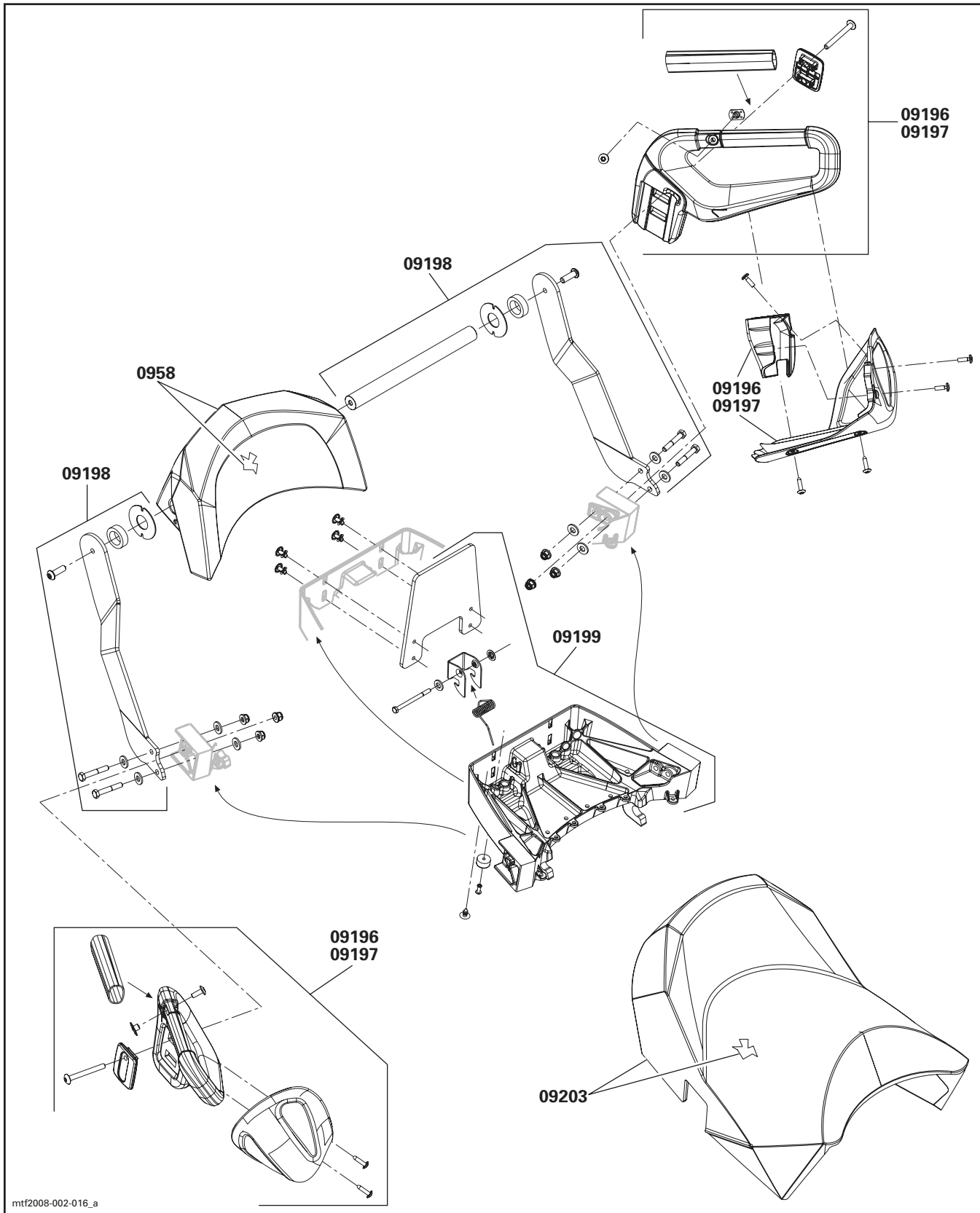



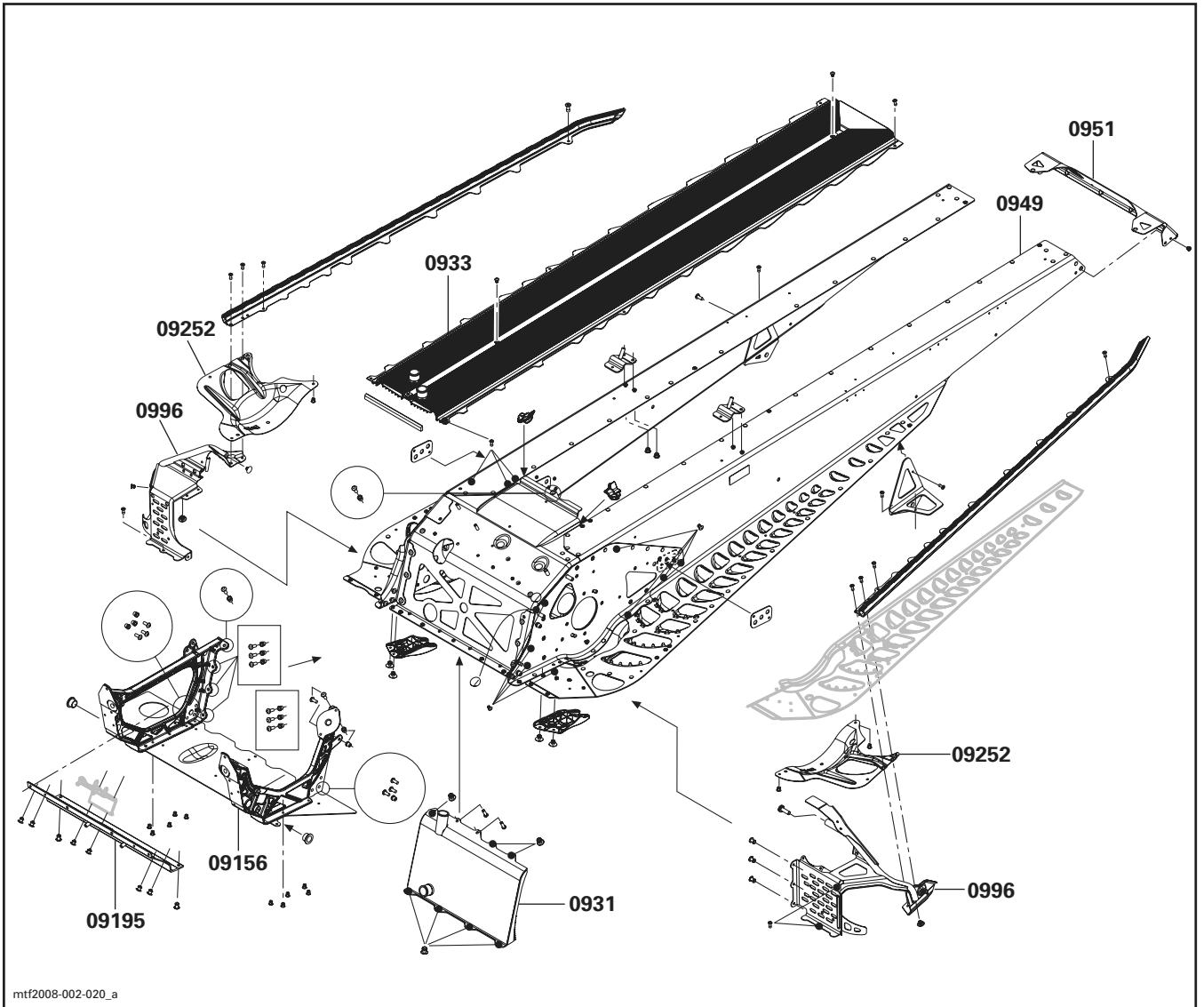

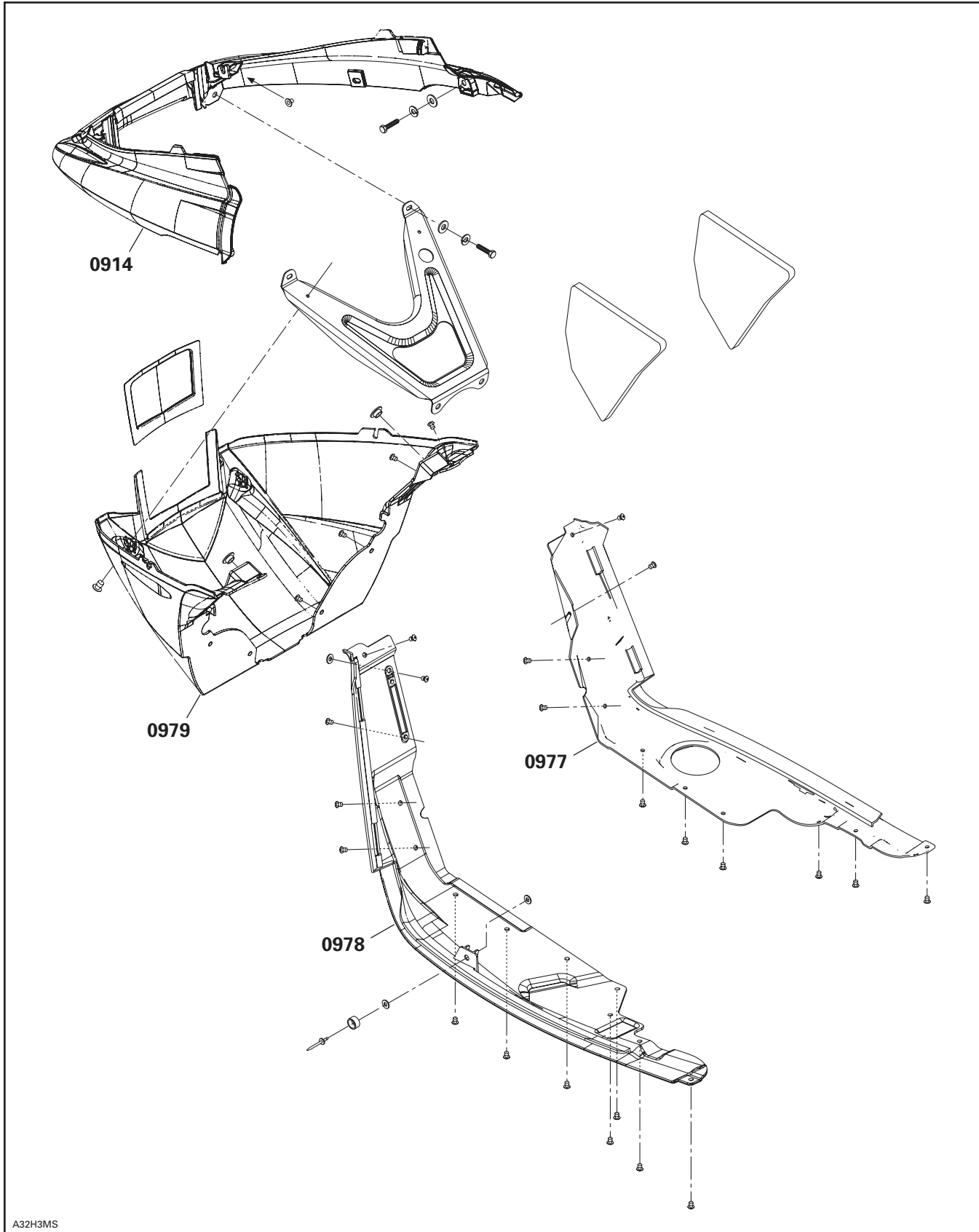

A32H3MS

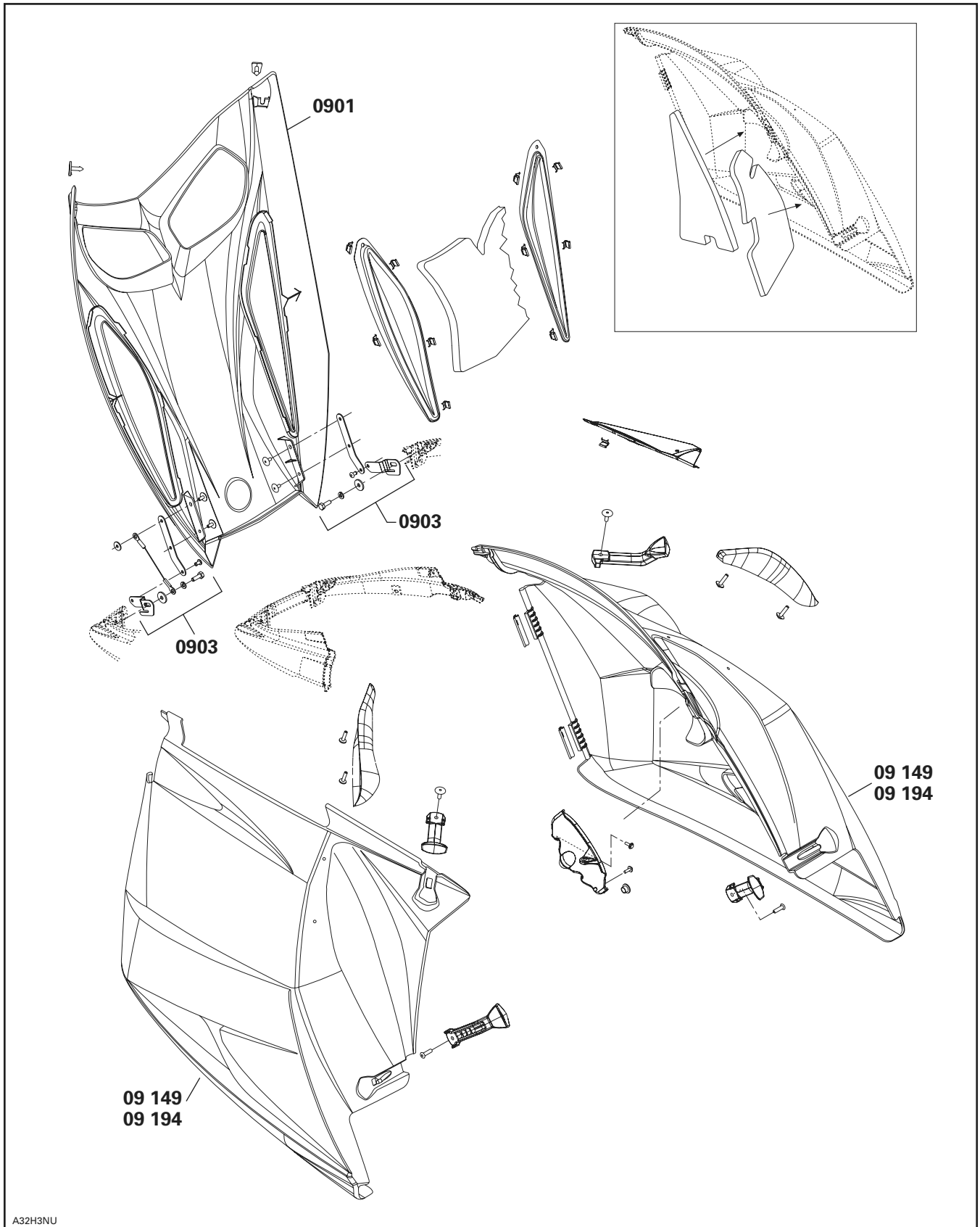

A32H3NU

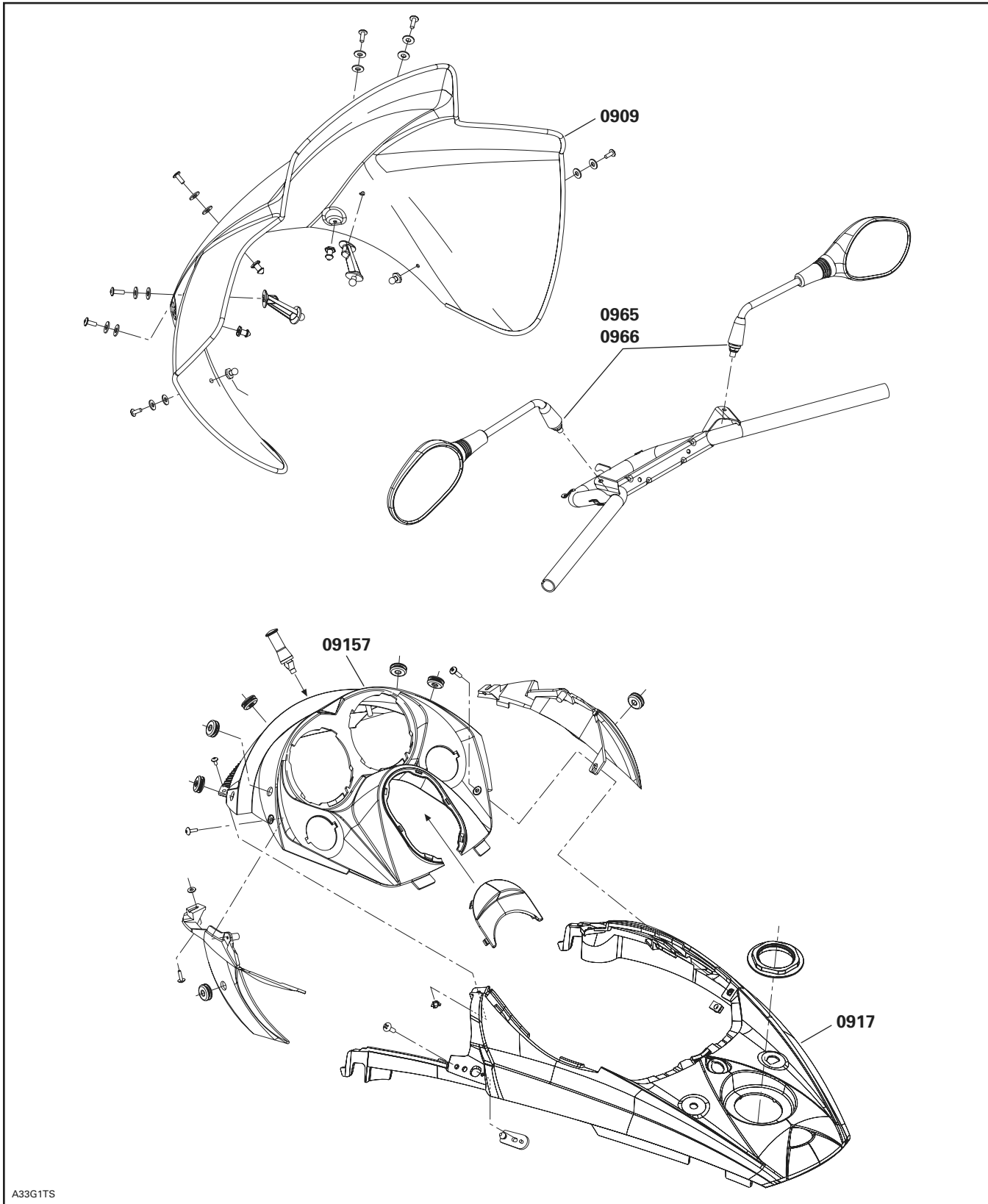

A33G1TS

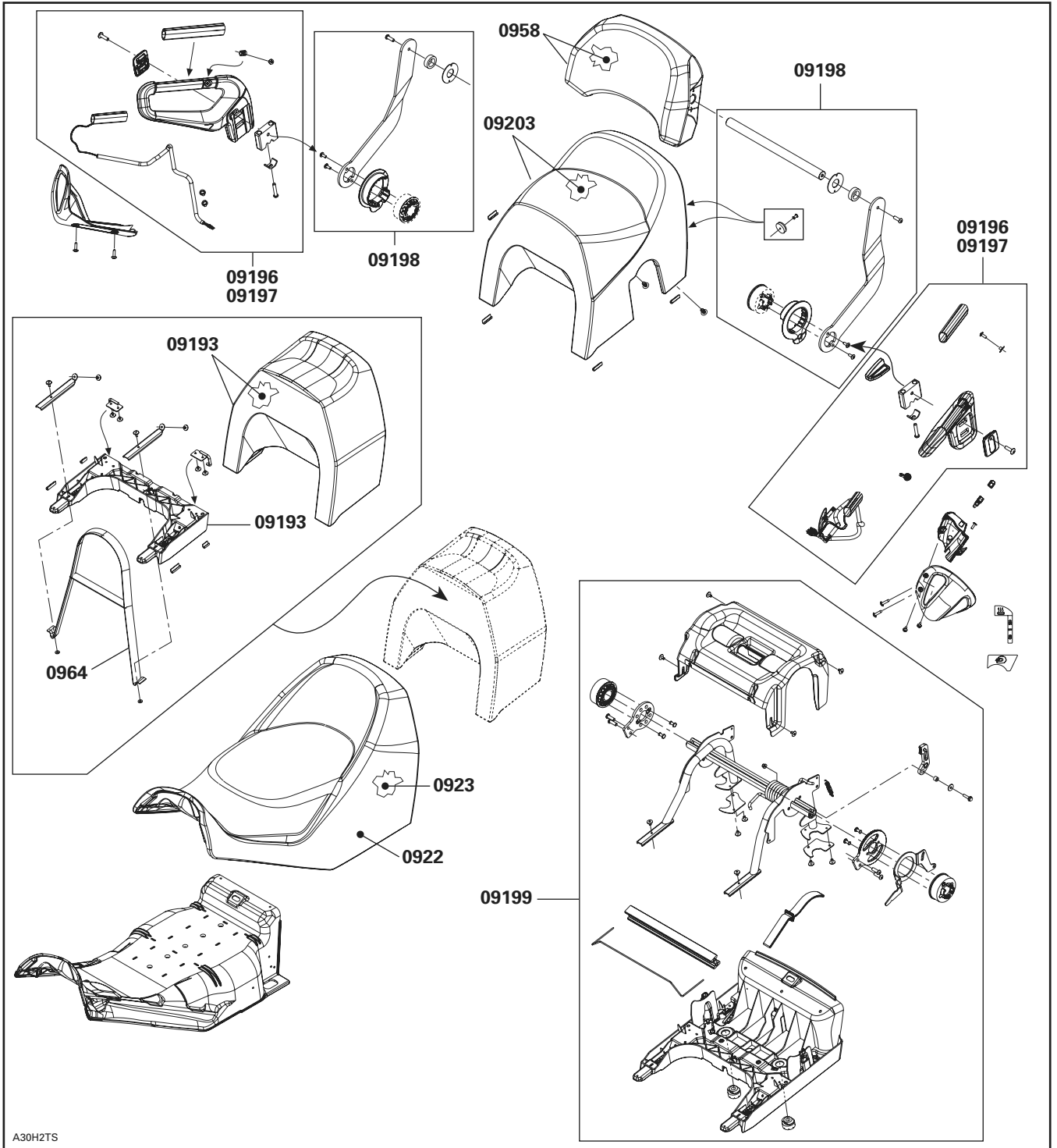

SYSTEM SYSTÈME	CODE	DESCRIPTION	MX Z/GSX 500 SS	GTX 500 SS	SKANDIC 600 SUV/WT	MX Z/GSX 600 HO SDI	MX Z 600 RS	GTX 600 HO SDI	EXPEDITION/ SKANDIC 600 HO SDI	SUMMIT 600 HO SDI
			11	12	13	14	15	16	17	18
10	00	<b>NO LABOR INVOLVED AUCUNE MAIN-D'OEUVRE IMPLIQUÉE</b>	0	0	0	0	0	0	0	0
10	01	IGNITION SWITCH INTERRUPTEUR D'ALLUMAGE	0.3	0.3	0.3	0.3	0.3	0.3	0.3	0.3
10	02	DIMMER SWITCH COMMUTATEUR D'ÉCLAIRAGE			0.3					
10	05	BRAKE LIGHT SWITCH INTERRUPTEUR DE FEU D'ARRÊT	0.3	0.3	0.3	0.3	0.3	0.3	0.3	0.3
10	06	TETHER CORD SWITCH OR DESS CAPUCHON COUPE-CIRCUIT OU DESS	0.3	0.3	0.3	0.3	0.3	0.3	0.3	0.3
10	07	IGNITION SWITCH BLOCK LOGEMENT D'INTERRUPTEUR D'ALLUMAGE	0.3	0.3	0.3	0.3	0.3	0.3	0.3	0.3
10	08	CURRENT OR GROUND WIRE FIL DE BATTERIE OU DE MASSE	0.3	0.3	0.3	0.3	0.3	0.3	0.3	0.3
10	09	HEADLAMP (ASS'Y) (ALL PARTS) PHARE (COMPLET) (TOUTES LES PIÈCES)	0.3	0.3	0.3	0.3	0.3	0.3	0.3	0.3
10	10	VOLTAGE REGULATOR RÉGULATEUR DE TENSION	0.7	0.4	0.3	0.7	0.7	0.4	0.3	0.4
10	12	TAIL LIGHT (ASS'Y) (ALL PARTS) FEU ARRIÈRE (COMPLET) (TOUTES LES PIÈCES)	0.3	0.3	0.3	0.3	0.3	0.3	0.3	0.3
10	13	BATTERY RACK, RETAINER ROD AND/OR RETAINER SUPPORT DE BATTERIE, TIGE DE RETENUE ET/OU COUVERCLE DE RETENUE	0.3	0.3	0.3	0.3	0.3	0.3	0.3	0.3
10	15	HEATED GRIPS POIGNÉES CHAUFFANTES	0.9	0.6	0.6	0.9	0.9	0.6	0.6	0.6
10	16	BULBS (ONE OR ALL) AMPOULES (UNE OU TOUTES)	0.5	0.3	0.3	0.5	0.5	0.3	0.3	0.3
10	17	HEATED THROTTLE LEVER MANETTE D'ACCÉLÉRATEUR CHAUFFANTE	0.3	0.3	0.3	0.3	0.3	0.3	0.3	0.3
10	18	HEAT GRIP SWITCH (1) INTERRUPTEUR DE POIGNÉE CHAUFFANTE (1)			0.3					
10	19	HEAT GRIP SWITCHES (2) INTERRUPTEURS DE POIGNÉE CHAUFFANTE (2)			0.3					
10	20	BACK UP BUZZER AVERTISSEUR DE MARCHE ARRIÈRE		0.3	0.3			0.3	0.3	0.3
10	28	SPEEDOMETER OR TACHOMETER (ALL PARTS) INDICATEUR DE VITESSE OU COMPTE-TOURS (TOUTES LES PIÈCES)		0.3	0.3			0.3	0.3	0.3
10	31	DC OUTLET PLUG PRISE D'ACCESSOIRE DC				0.3				
10	32	AIR PRESSURE SENSOR CAPTEUR DE PRESSION D'AIR				0.3	0.3	0.3	0.3	0.3
10	34	ELECTRONIC MODULE MODULE ÉLECTRONIQUE	0.3	0.3	0.3	0.3	0.3	0.3	0.3	0.3
10	42	TEMPERATURE SENSOR CAPTEUR DE TEMPÉRATURE		0.3		0.3	0.3	0.3	0.3	0.3
10	44	FUEL GAUGE/TEMPERATURE AND COMPONENT INDICATEUR DE NIVEAU ESSENCE/TEMPÉRATURE ET COMPOSANTE		0.3				0.3		

SYSTEM SYSTÈME	CODE	DESCRIPTION	MX Z/GSX 500 SS	GTX 500 SS	SKANDIC 600 SUV/WT	MX Z/GSX 600 HO SDI	MX Z 600 RS	GTX 600 HO SDI	EXPEDITION/ SKANDIC 600 HO SDI	SUMMIT 600 HO SDI
			11	12	13	14	15	16	17	18
10	49	MULTIFUNCTION GAUGE CADRAN MULTIFONCTION	0.3			0.3	0.3			
10	51	MAIN WIRE HARNESS CÂBLAGE PRINCIPAL	1.4			1.8	1.4			
10	59	REAR HEATED GRIP (1) POIGNÉE CHAUFFANTE ARRIÈRE (1)						0.5		
10	60	REAR HEATED GRIPS (2) POIGNÉES CHAUFFANTES ARRIÈRE (2)						0.9		
10	74	EXHAUST TEMPERATURE SENSOR CAPTEUR DE TEMPÉRATURE D'ÉCHAPPEMENT				0.3	0.3	0.3	0.3	0.3

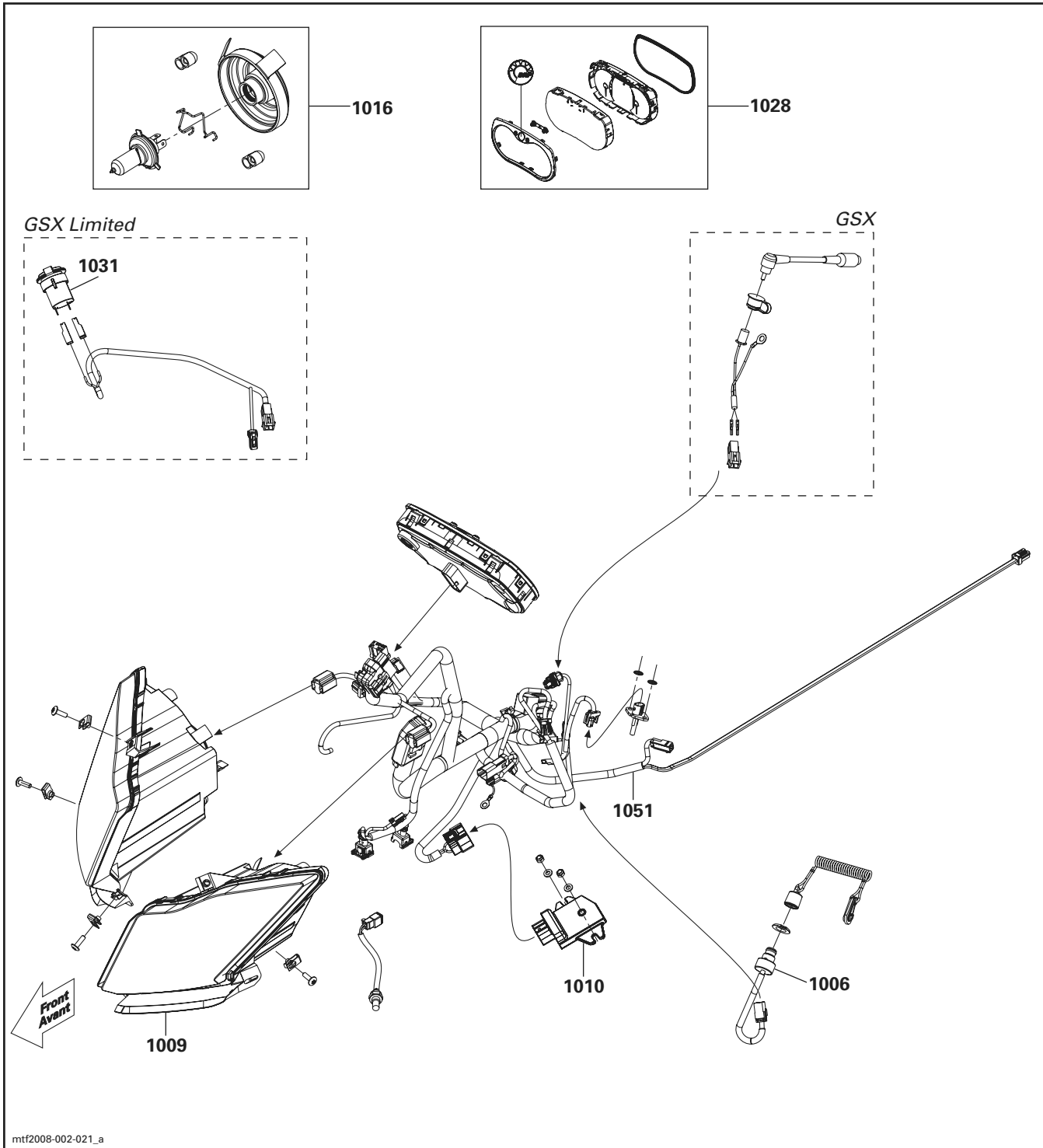



SYSTEM SYSTÈME	CODE	DESCRIPTION	MX Z 600 HO	MX Z 600 HO (E)	SKANDIC 600 WT/SUV	MX Z 600 HO SDI	MX Z 600 HO SDI (E), GSX 600 HO SDI	GTX 600 HO SDI	EXPEDITION 600 HO SDI	SUMMIT 600 HO SDI	SUMMIT 600 HO SDI (E)
			16	17	18	19	20	21	22	23	24
11	00	<b>NO LABOR INVOLVED</b> <b>AUCUNE MAIN-D'OEUVRE IMPLIQUÉE</b>	0	0	0	0	0	0	0	0	0
11	WT 1	SCHEDULED MAINTENANCE TRACKING SUIVI DES ENTRETIENS PLANIFIÉS	0	0	0	0	0	0	0	0	0



**FLAT RATE TIME  
SUGGESTION**

DEALER'S NO.: \_\_\_\_\_ DATE: \_\_\_\_\_

DEALER'S NAME: \_\_\_\_\_

FILE IDENTIFICATION NO.: \_\_\_\_\_

ADDRESS: \_\_\_\_\_  
\_\_\_\_\_  
\_\_\_\_\_

YEAR	MODEL DESCRIPTION	OPERATION	JOB CODE	PRESENT FLAT RATE	SUGGESTED FLAT RATE

Detailed procedure used:

\_\_\_\_\_  
\_\_\_\_\_  
\_\_\_\_\_  
\_\_\_\_\_  
\_\_\_\_\_  
\_\_\_\_\_  
\_\_\_\_\_

Signature: \_\_\_\_\_

**BOMBARDIER RECREATIONAL PRODUCTS INC.**

WARRANTY DEPARTMENT  
75, J.A. BOMBARDIER ST.  
SHERBROOKE (QUEBEC)  
CANADA J1L 1W3

FAX NUMBER: 819-566-3590

**BARÈME DE TEMPS À TAUX FIXE  
SUGGESTION**

N° DU CONCESSIONNAIRE: \_\_\_\_\_ DATE: \_\_\_\_\_

NOM DU CONCESSIONNAIRE: \_\_\_\_\_

N° D'IDENTIFICATION DU DOSSIER: \_\_\_\_\_

ADRESSE: \_\_\_\_\_

\_\_\_\_\_  
\_\_\_\_\_

ANNÉE	DESCRIPTION DU MODÈLE	OPÉRATION	CODE DE TRAVAUX	TTP ACTUEL	TTP SUGGÉRÉ

Détails de la marche à suivre:

\_\_\_\_\_  
\_\_\_\_\_  
\_\_\_\_\_  
\_\_\_\_\_  
\_\_\_\_\_  
\_\_\_\_\_  
\_\_\_\_\_

Signature: \_\_\_\_\_

**BOMBARDIER PRODUITS RÉCRÉATIFS INC.**

SERVICE DE GARANTIE  
75, RUE J.-A. BOMBARDIER  
SHERBROOKE (QUÉBEC)  
CANADA J1L 1W3

N° DU TÉLÉCOPIEUR: 819-566-3590