

REAR SUSPENSION AND TRACK SUSPENSION ARRIÈRE ET CHENILLE

SYSTEM SYSTÈME	CODE	DESCRIPTION	MACH Z/AMX Z 995 SDI	MACH Z/AMX Z 995 SDI (E)	SUMMIT 995 SDI	SUMMIT 995 SDI (E)	EXPEDITION SPORT LEGEND TOURING V800	EXPEDITION TUV V800	LEGEND TRAIL TUNDRA V800	SKANDIC SWT V800
			30	31	32	33	34	35	36	37
08	00	NO LABOR INVOLVED AUCUNE MAIN-D'OEUVRE IMPLIQUÉE	0	0	0	0	0	0	0	0
08	01	SLIDER SHOE (1) GLISSIÈRE (1)	0.5	0.5	0.5	0.5	0.5	0.5	0.5	0.5
08	02	SLIDER SHOES (2) GLISSIÈRES (2)	0.7	0.7	0.7	0.7	0.7	0.7	0.7	0.7
08	03	RUNNER (1) PORTE-GLISSIÈRE (1)	1.2	1.2	1.2	1.2	1.2	1.7	1.2	1.7
08	04	RUNNERS (2) PORTE-GLISSIÈRES (2)	1.5	1.5	1.5	1.5	1.5	2.2	1.5	2.2
08	09	FRONT IDLER WHEEL AND/OR BEARING (1) ROUE DE SUPPORT AVANT ET/OU ROULEMENT (1)	0.3	0.3	0.3	0.3	0.3	0.3	0.3	0.3
08	10	FRONT IDLER WHEELS AND/OR BEARINGS AND/OR SHAFTS (2) ROUES DE SUPPORT AVANT ET/OU ROULEMENTS ET/OU ARBRES (2)	0.4	0.4	0.4	0.4	0.4	0.4	0.4	0.4
08	11	FRONT IDLER WHEEL SUPPORT (1) SUPPORT DE ROUE AVANT (1)	0.3	0.3	0.3	0.3	0.3	0.5	0.3	0.5
08	12	FRONT IDLER WHEELS SUPPORTS (2) SUPPORTS DE ROUE AVANT (2)	0.4	0.4	0.4	0.4	0.4		0.4	
08	13	CENTER IDLER WHEEL AND/OR BEARING (1) ROUE DE SUPPORT CENTRALE ET/OU ROULEMENT (1)	0.3	0.3	0.3	0.3	0.3	0.3	0.3	0.3
08	14	CENTER IDLER WHEELS AND/OR BEARINGS AND/OR SHAFTS (2) ROUES DE SUPPORT CENTRALES ET/OU ROULEMENTS ET/OU ARBRES (2)	0.4	0.4	0.4	0.4	0.4	0.3	0.4	0.3
08	15	CENTER IDLER WHEEL SUPPORT (1) SUPPORT DE ROUE CENTRALE (1)	0.3	0.3	0.3	0.3	0.3	0.3	0.3	0.3
08	17	REAR IDLER AND/OR BEARING (1) ROUE DE SUPPORT ARRIÈRE ET/OU ROULEMENT (1)	0.4	0.4	0.4	0.4	0.4	0.4	0.4	0.4
08	18	REAR IDLERS AND/OR BEARINGS (2) ROUES DE SUPPORT ARRIÈRE ET/OU ROULEMENTS (2)	0.5	0.5	0.5	0.5	0.5	0.4	0.5	0.4
08	19	REAR IDLER WHEELS AXLE ESSIEU DE ROUES DE SUPPORT ARRIÈRE	0.5	0.5	0.5	0.5	0.5	0.4	0.5	0.4
08	22	TAIL PIVOT IDLER WHEEL, INSIDE (1) ROUE SUPPORT DE PIVOT ARRIÈRE ET/OU ROULEMENT INT. (1)						0.3		0.3
08	23	TAIL PIVOT IDLER WHEELS OR AXLE (2) ROUES SUPPORT DE PIVOT ARRIÈRE/ROULEMENT OU ESSIEU (2)						0.3		0.3
08	29	AXEL (STOPPER STRAP) AXE (COURROIE D'ARRÊT)					0.3	0.3	0.3	0.3
08	31	TRACK TENSION ADJUSTER (1) PLAQUE DE RÉGLAGE TENSION CHENILLE (1)	0.3	0.3	0.3	0.3	0.3	0.4	0.3	0.4
08	32	TRACK TENSION ADJUSTERS (2) PLAQUES DE RÉGLAGE TENSION CHENILLE (2)	0.4	0.4	0.4	0.4	0.4	0.4	0.4	0.4
08	33	RUNNER RUBBER STOPPER (1) BUTÉE DE CAOUTCHOUC DE PORTE-GLISSIÈRE (1)	0.3	0.3	0.3	0.3	0.3	0.3	0.3	0.3
08	34	RUNNER RUBBER STOPPERS (2) BUTÉES DE CAOUTCHOUC DE PORTE-GLISSIÈRE (2)	0.4	0.4	0.4	0.4	0.4	0.4	0.4	0.4

REAR SUSPENSION AND TRACK SUSPENSION ARRIÈRE ET CHENILLE

08

SYSTEM/SYSTÈME

SYSTEM SYSTÈME	CODE	DESCRIPTION	MACH Z/MX Z 995 SDI	MACH Z/MX Z 995 SDI (E)	SUMMIT 995 SDI	SUMMIT 995 SDI (E)	EXPEDITION SPORT LEGEND TOURING V800	EXPEDITION TUV V800	LEGEND TRAIL TUNDRA V800	SKANDIC SWT V800
			30	31	32	33	34	35	36	37
08	35	FRONT ARM AND/OR AXLE BRAS AVANT ET/OU ESSIEU	0.8	0.8	0.8	0.8	0.8	1.0	0.8	1.0
08	36	FRONT ARM STOPPER STRAP/STOPPER BOLT COURROIE D'ARRÊT BRAS AVANT/BOULON D'ARRÊT	0.3	0.3	0.3	0.3	0.3	0.4	0.3	0.4
08	37	FRONT ARM SUPPORT SUPPORT DE BRAS AVANT						0.6		0.6
08	40	REAR ARM AND/OR AXLE BRAS ARRIÈRE ET/OU ESSIEU	0.7	0.7	0.7	0.7	0.7	0.9	0.7	0.9
08	41	REAR ARM IDLER WHEELS (1-2) AND/OR SHAFT-CROSS ROUES DE SUPPORT BRAS ARRIÈRE (1-2) ET/OU AXE TRANSVERSALE	0.3	0.3	0.3	0.3	0.3	0.4	0.3	0.4
08	42	REAR ARM SHACKLE JUMELLE DE BRAS ARRIÈRE	0.3	0.3	0.3	0.3	0.3		0.3	
08	44	REAR AND FRONT ARMS BRAS ARRIÈRE ET AVANT	1.5	1.5	1.5	1.5	1.5	1.8	1.5	1.8
08	48	TAIL PIVOT SUPPORT (1) SUPPORT DE PIVOT ARRIÈRE (1)						1.0		1.0
08	49	TAIL PIVOT SUPPORTS (2) SUPPORTS DE PIVOT ARRIÈRE (2)						1.3		1.3
08	50	REAR TORSION SPRING AND/OR WHEEL (1) RESSORT DE TORSION ARRIÈRE ET/OU ROUE (1)	0.3	0.3	0.3	0.3	0.3	0.4	0.3	0.4
08	51	REAR TORSION SPRINGS AND/OR WHEELS (2) RESSORTS DE TORSION ET/OU ROUES (2)	0.4	0.4	0.4	0.4	0.4	0.5	0.4	0.5
08	52	TORSION SPRING SUPPORT SUPPORT DE RESSORT DE TORSION	0.3	0.3	0.3	0.3	0.3	0.3	0.3	0.3
08	53	SPRING ADJUSTMENT CAM (1) CAME DE RÉGLAGE DE RESSORT (1)	0.3	0.3	0.3	0.3	0.3	0.3	0.3	0.3
08	54	SPRING ADJUSTMENT CAMS (2) CAMES DE RÉGLAGE DE RESSORT (2)	0.4	0.4	0.4	0.4	0.4	0.4	0.4	0.4
08	55	SHOCK AND/OR SPRING AND/OR BUSHING AMORTISSEUR ET/OU RESSORT ET/OU DOUILLE	0.3	0.3	0.3	0.3	0.3	0.3	0.3	0.3
08	65	BEARING HOUSING OUTSIDE (DRIVE AXLE) LOGEMENT DES ROULEMENTS D'EXTÉRIEUR (ESSIEU MOTEUR)	0.3	0.3	0.3	0.3	0.3		0.3	
08	66	DRIVE AXLE BEARING AND/OR SEAL ROULEMENT D'ESSIEU MOTEUR ET/OU JOINT	2.6	2.6	2.6	2.6	2.3	2.6	2.3	2.6
08	67	DRIVE AXLE, SPROCKET AND/OR FLANGE (1) ROUE DENTÉE, ESSIEU MOTEUR ET/OU FLASQUE (1)	2.8	2.8	2.8	2.8	2.5	2.8	2.5	2.8
08	68	DRIVE AXLES, SPROCKETS, FLANGES (2 OR MORE) ROUES DENTÉES, ESSIEUX MOTEUR, FLASQUES (2 OU PLUS)	3.4	3.4	3.4	3.4	3.1	3.2	3.1	3.2
08	69	TRACK (1) CHENILLE (1)	1.9	1.9	1.9	1.9	1.6	2.0	1.6	2.0
08	71	CLEATS AND/OR GUIDES (0-9) SEGMENTS GUIDE ET/OU GUIDES (0-9)	0.3	0.3	0.3	0.3	0.3	0.3	0.3	0.3
08	72	CLEATS AND/OR GUIDES (10-14) SEGMENTS GUIDE ET/OU GUIDES (10-14)	0.4	0.4	0.4	0.4	0.4	0.4	0.4	0.4

SYSTEM SYSTÈME	CODE	DESCRIPTION	MACH Z/MX Z 995 SDI	MACH Z/MX Z 995 SDI (E)	SUMMIT 995 SDI	SUMMIT 995 SDI (E)	EXPEDITION SPORT LEGEND TOURING V800	EXPEDITION TUV V800	LEGEND TRAIL TUNDRA V800	SKANDIC SWT V800
			30	31	32	33	34	35	36	37
08	73	CLEATS AND/OR GUIDES (15-19) SEGMENTS GUIDE ET/OU GUIDES (15-19)	0.5	0.5	0.5	0.5	0.5	0.5	0.5	0.5
08	74	CLEATS AND/OR GUIDES (20-24) SEGMENTS GUIDE ET/OU GUIDES (20-24)	0.6	0.6	0.6	0.6	0.6	0.6	0.6	0.6
08	75	CLEATS AND/OR GUIDES (25-29) SEGMENTS GUIDE ET/OU GUIDES (25-29)	0.7	0.7	0.7	0.7	0.7	0.7	0.7	0.7
08	76	CLEATS AND/OR GUIDES (30-34) SEGMENTS GUIDE ET/OU GUIDES (30-34)	0.8	0.8	0.8	0.8	0.8	0.8	0.8	0.8
08	77	CLEATS AND/OR GUIDES (35-39) SEGMENTS GUIDE ET/OU GUIDES (35-39)	0.9	0.9	0.9	0.9	0.9	0.9	0.9	0.9
08	78	CLEATS AND/OR GUIDES (40-44) SEGMENTS GUIDE ET/OU GUIDES (40-44)	1.0	1.0	1.0	1.0	1.0	1.0	1.0	1.0
08	79	CLEATS AND/OR GUIDES (45-49) SEGMENTS GUIDE ET/OU GUIDES (45-49)	1.1	1.1	1.1	1.1	1.1	1.1	1.1	1.1
08	80	CLEATS AND/OR GUIDES (50-54) SEGMENTS GUIDE ET/OU GUIDES (50-54)	1.2	1.2	1.2	1.2	1.2	1.2	1.2	1.2
08	81	CLEATS AND/OR GUIDES (55-59) SEGMENTS GUIDE ET/OU GUIDES (55-59)	1.3	1.3	1.3	1.3	1.3	1.3	1.3	1.3
08	82	CLEATS AND/OR GUIDES (60-64) SEGMENTS GUIDE ET/OU GUIDES (60-64)	1.4	1.4	1.4	1.4	1.4	1.4	1.4	1.4
08	83	CLEATS AND/OR GUIDES (65-70) SEGMENTS GUIDE ET/OU GUIDES (65-70)	1.5	1.5	1.5	1.5	1.5	1.5	1.5	1.5
08	85	ADJUSTMENT SCREW (1) VIS D'AJUSTEMENT (1)	0.3	0.3	0.3	0.3	0.3	0.3	0.3	0.3
08	86	ADJUSTMENT SCREWS (2) VIS D'AJUSTEMENT (2)	0.4	0.4	0.4	0.4	0.4	0.4	0.4	0.4
08	87	SHOCK SUPPORT AND/OR AXLE SUPPORT D'AMORTISSEUR ET/OU AXE	0.4	0.4	0.4	0.4	0.4	0.4	0.4	0.4
08	88	FRONT SHOCK AND/OR SPRING AMORTISSEUR AVANT ET/OU RESSORT	0.5	0.5	0.5	0.5	0.5		0.5	
08	89	FRONT WHEELS SUPPORT AND/OR BEARINGS (3) ROUES DE SUPPORT AVANT ET/OU ROULEMENTS À BILLE (3)	0.5	0.5	0.5	0.5	0.5		0.5	
08	90	FRONT WHEELS SUPPORT AND/OR BEARINGS (4) ROUES DE SUPPORT AVANT ET/OU ROULEMENTS À BILLE (4)	0.7	0.7	0.7	0.7				
08	91	REAR PIVOT ARM BRAS DE PIVOT ARRIÈRE						0.7		0.7
08	92	FRONT TORSION SPRING (1) RESSORT DE TORSION AVANT (1)						0.5		0.5
08	93	FRONT TORSION SPRINGS (2) RESSORTS DE TORSION AVANT (2)						0.5		0.5
08	119	MAGNETIC SENSOR CAPTEUR MAGNÉTIQUE	0.3	0.3	0.3	0.3	0.3	0.4	0.3	0.4

REAR SUSPENSION AND TRACK SUSPENSION ARRIÈRE ET CHENILLE

08
SYSTEM/SYSTEME

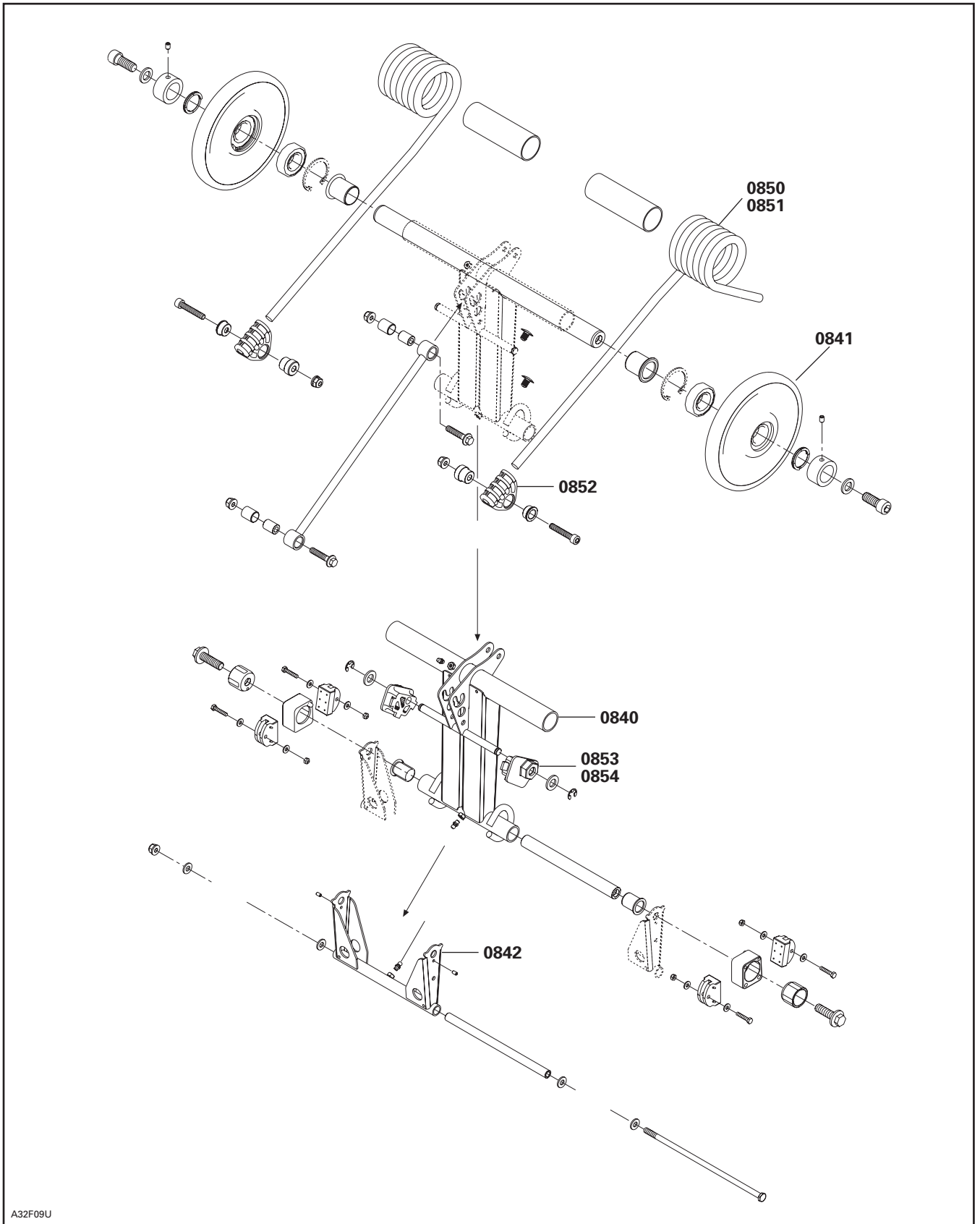

A32F09U

**REAR SUSPENSION AND TRACK
SUSPENSION ARRIÈRE ET CHENILLE**

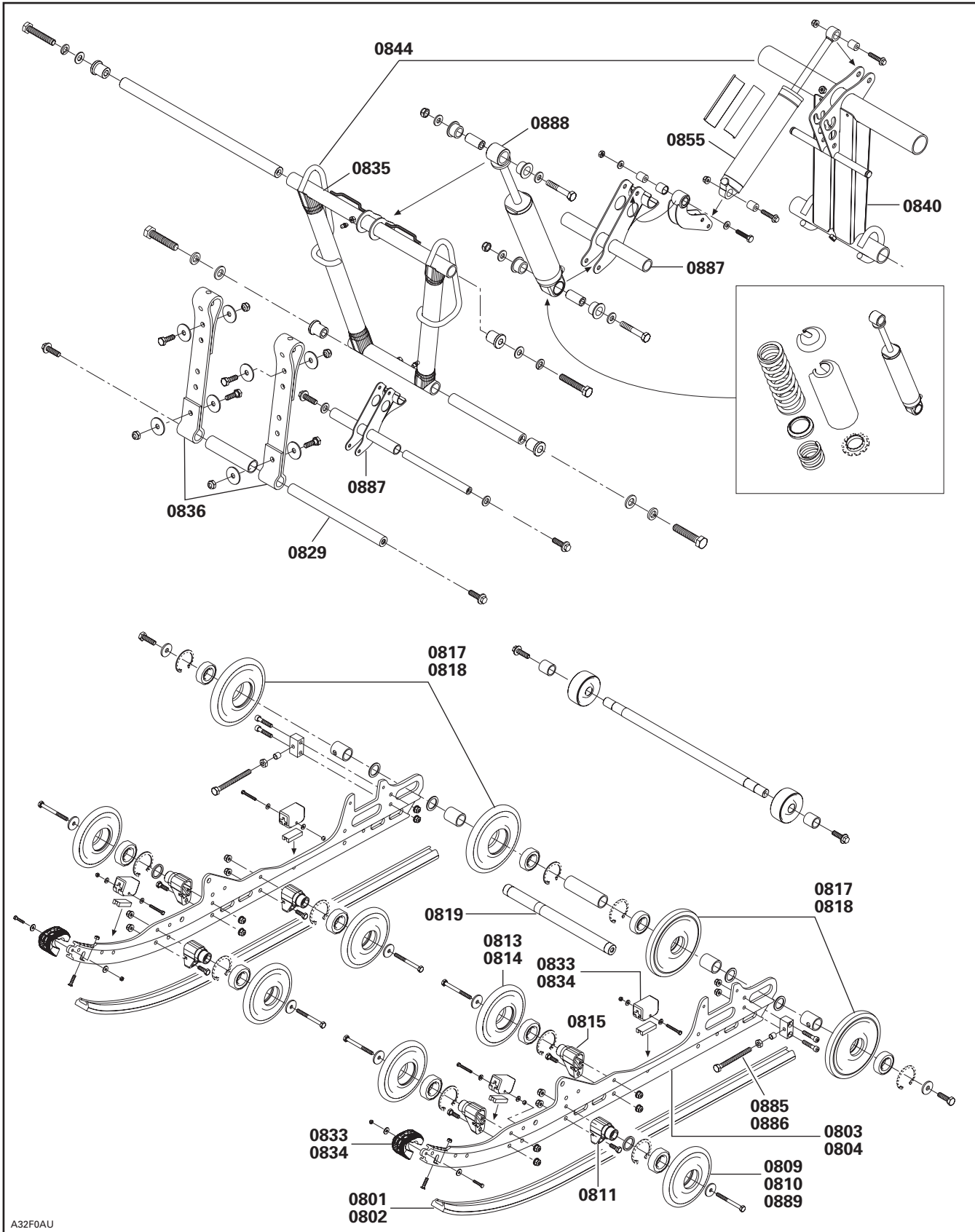

A32F0AU

REAR SUSPENSION AND TRACK SUSPENSION ARRIÈRE ET CHENILLE

08
SYSTEM/SYSTÈME

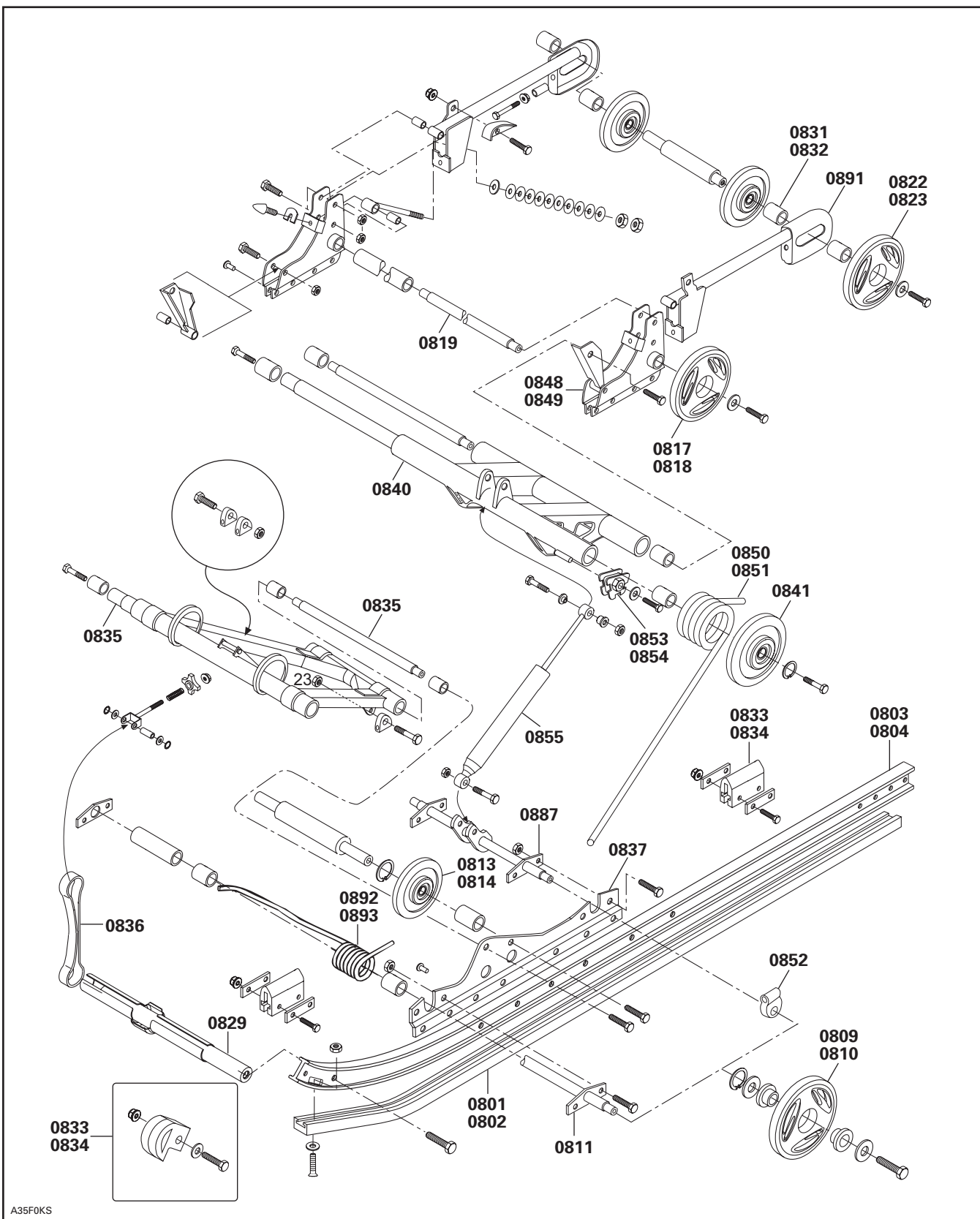

SYSTEM SYSTÈME	CODE	DESCRIPTION	MACH Z/MX Z 995 SDI	MACH Z/MX Z 995 SDI (E)	SUMMIT 995 SDI	SUMMIT 995 SDI (E)	EXPEDITION SPORT LEGEND TOURING V800	EXPEDITION TUV V800	LEGEND TRAIL TUNDRA V800	SKANDIC SWT V800
			30	31	32	33	34	35	36	37
09	00	NO LABOR INVOLVED AUCUNE MAIN-D'OEUVRE IMPLIQUÉE	0	0	0	0	0	0	0	0
09	01	HOOD CAPOT	0.9	0.9	0.9	0.9	1.2	2.3	1.2	2.3
09	03	HOOD HINGE CHARNIÈRE DU CAPOT	0.3	0.3	0.3	0.3				
09	05	HOOD DECALS (RH or LH) AUTOCOLLANTS DU CAPOT (GA OU DR)	0.3	0.3	0.3	0.3	0.3	0.3	0.3	0.3
09	06	HOOD DECALS (ALL) AUTOCOLLANTS DU CAPOT (TOUS)	0.9	0.9	0.9	0.9	0.9	0.9	0.9	0.9
09	07	HOOD LATCH (1 OR 2) ATTACHE DU CAPOT (1 OU 2)	0.3	0.3	0.3	0.3	0.3	0.3	0.3	0.3
09	09	WINDSHIELD PARE-BRISE	0.3	0.3	0.3	0.3	0.3	0.3	0.3	0.3
09	13	CARGO RACK SUPPORT À BAGAGES			0.4	0.4	0.3		0.3	0.5
09	14	FRONT BUMPER PARE-CHOCS AVANT	0.3	0.3	0.3	0.3	0.3	0.3	0.3	0.6
09	17	CONSOLE CONSOLE	0.6	0.6	0.6	0.6	0.6	0.6	0.6	0.6
09	21	SEAT ASS'Y OR BACKREST SIÈGE COMPLET OU DOSSIER	0.3	0.3	0.3	0.3	0.3	0.3	0.3	0.3
09	22	SEAT COVER AND/OR FOAM HOUSSE DE SIÈGE ET/OU MOUSSE	1.1	1.1	1.1	1.1	1.2	1.1	1.0	1.1
09	24	BOTTOM PAN COQUE								2.0
09	34	REAR BUMPER PARE-CHOCS ARRIÈRE	0.3	0.3	0.3	0.3	0.3		0.3	
09	35	HITCH SUPPORT (ALL PARTS) SUPPORT D'ATTELAGE (TOUTES LES PIÈCES)						0.3	0.3	0.3
09	49	FRAME ASS'Y OR FRONT MEMBER CHÂSSIS COMPLET OU CADRE AVANT	13.8	13.8	14.2	14.2	13.2	12.5	13.0	12.0
09	51	REAR CAP FRAME CAPUCHON ARRIÈRE DU CHÂSSIS			0.8	0.8				
09	55	SNOW GUARD (1) GARDE-NEIGE (1)	0.3	0.3	0.3	0.3	0.3	0.3	0.3	0.3
09	58	BACKREST AND/OR COVER DOSSIER ET/OU HOUSSE					0.3	0.3		0.3
09	62	BOTTOM PAN REINFORCEMENT (RH) RENFORT DE COQUE (DR)						0.6		0.7
09	63	BOTTOM PAN REINFORCEMENT (LH) RENFORT DE COQUE (GA)						0.6		0.7
09	65	MIRROR (1) RÉTROVISEUR (1)					0.3	0.3	0.3	0.3

SYSTEM SYSTÈME	CODE	DESCRIPTION	MACH Z/MX Z 995 SDI	MACH Z/MX Z 995 SDI (E)	SUMMIT 995 SDI	SUMMIT 995 SDI (E)	EXPEDITION SPORT LEGEND TOURING V800	EXPEDITION TUV V800	LEGEND TRAIL TUNDRA V800	SKANDIC SWT V800
			30	31	32	33	34	35	36	37

09	66	MIRRORS (2) RÉTROVISEURS (2)					0.3	0.3	0.3	0.3
09	72	TUNNEL DECAL (1 OR 2) DÉCALQUE DE TUNNEL (1 OU 2)								0.3
09	77	RH BOTTOM PAN COQUE CÔTÉ DROIT	0.7	0.7	0.7	0.7	0.7	1.7	0.7	
09	78	LH BOTTOM PAN COQUE CÔTÉ GAUCHE	0.7	0.7	0.7	0.7	0.7	1.5	0.7	
09	79	CENTER BOTTOM PAN COQUE PARTIE CENTRALE	0.5	0.5	0.5	0.5	0.6	0.7	0.6	
09	80	FRONT GRILL (RH AND/OR LH) GRILLE AVANT (DR ET/OU GA)	0.3	0.3	0.3	0.3	0.3		0.3	0.3
09	81	SIDE GRILL (RH AND/OR LH) GRILLE LATÉRALE (DR ET/OU GA)	0.3	0.3	0.3	0.3	0.3	0.3	0.3	0.3
09	82	CABLE RETAINER (RH AND/OR LH) CÂBLE DE RETENUE (DR ET/OU GA)						0.3		0.3
09	108	REAR SEAT SIÈGE ARRIÈRE					0.4		0.4	
09	120	FRONT LIGHT FASCIA FASCIA DE LUMIÈRE AVANT					0.3	0.3	0.3	0.3
09	149	ENGINE SIDE PANELS (2) PANNEAUX MOTEUR (2)	0.9	0.9	0.9	0.9	0.9		0.9	
09	156	FRONT FRAME CHÂSSIS AVANT	6.0	6.0	6.0	6.0	4.7		4.7	
09	157	UPPER CONSOLE CONSOLE SUPÉRIEUR	0.3	0.3	0.3	0.3				
09	163	MEMBER (RH OR LH) MEMBRURE (DR OU GA)	0.4	0.4	0.4	0.4	0.4		0.4	
09	166	SUPERIOR PANEL MOULDING (RH OR LH) ENJOLIVEUR SUPÉRIEUR DE PANNEAU (DR OU GA)	0.3	0.3	0.3	0.3				
09	168	FRONT GRILL GRILLE AVANT	0.3	0.3	0.3	0.3		0.3		
09	191	SIDE PANEL DECAL (RH OR LH) (1) DÉCALQUES DE PANNEAU (DR OU GA) (1)	0.3	0.3	0.3	0.3	0.3		0.3	
09	192	SIDE PANEL DECALS (RH OR LH) (ALL) DÉCALQUES DE PANNEAU (DR OU GA) (TOUS)	0.6	0.6	0.6	0.6	0.6		0.6	
09	194	ENGINE SIDE PANEL (RH OR LH) PANNEAU MOTEUR (DR OU GA)	0.5	0.5	0.5	0.5	0.4		0.4	
09	195	FRONT PLATE PLAQUE AVANT					3.7		3.7	
09	201	FRONT PLATE (FRONT FRAME) PLAQUE FRONTALE (CHÂSSIS AVANT)	3.2	3.2	3.2	3.2	3.0		3.0	
09	202	INFERIOR BOTTOM PAN (LH OR RH) COQUE INFÉRIEUR (GA OU DR)					0.6		0.6	

Skandic/Expedition TUV

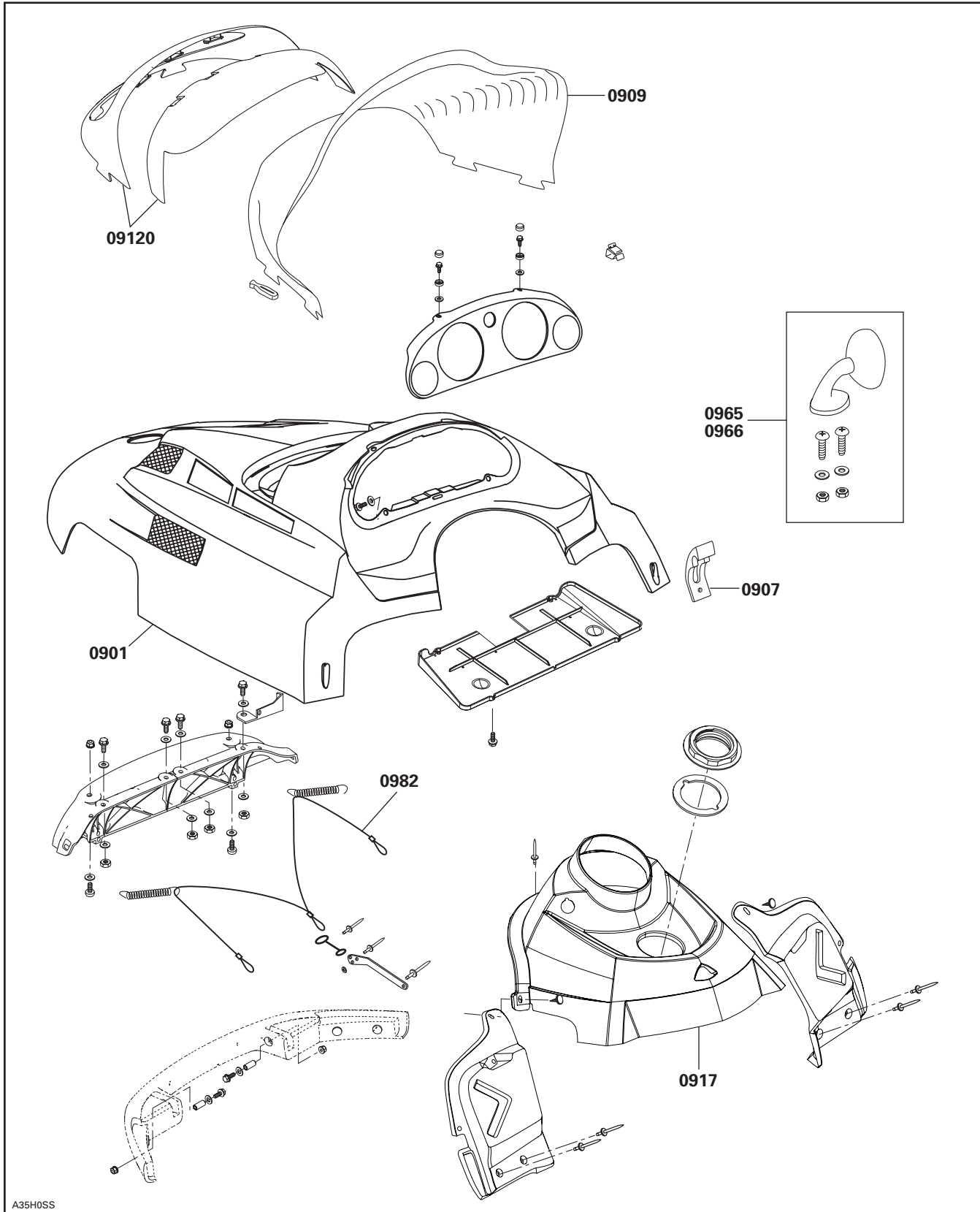

A35H0SS

RF Chassis
Châssis RF

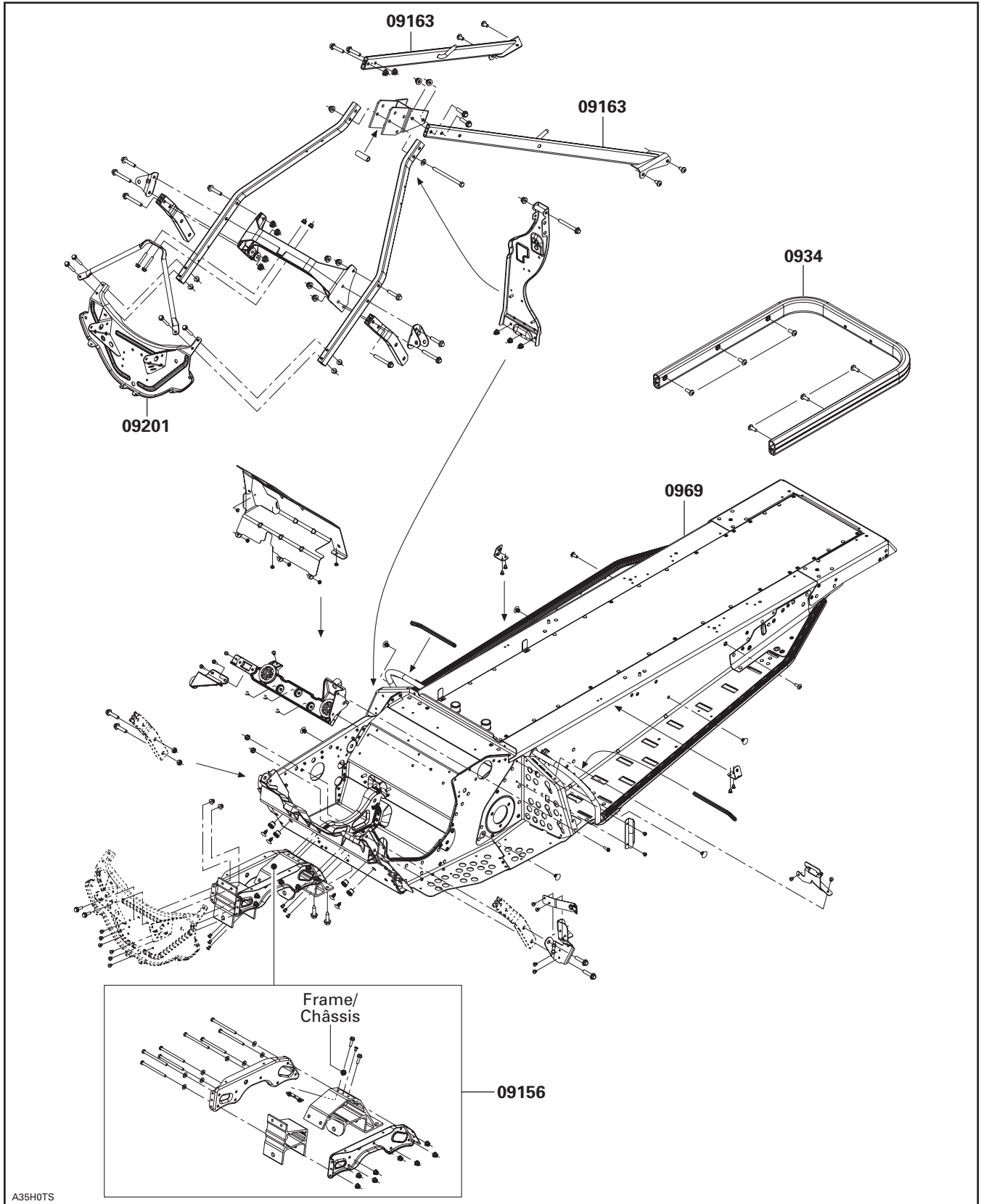

**RF Chassis
Châssis RF**

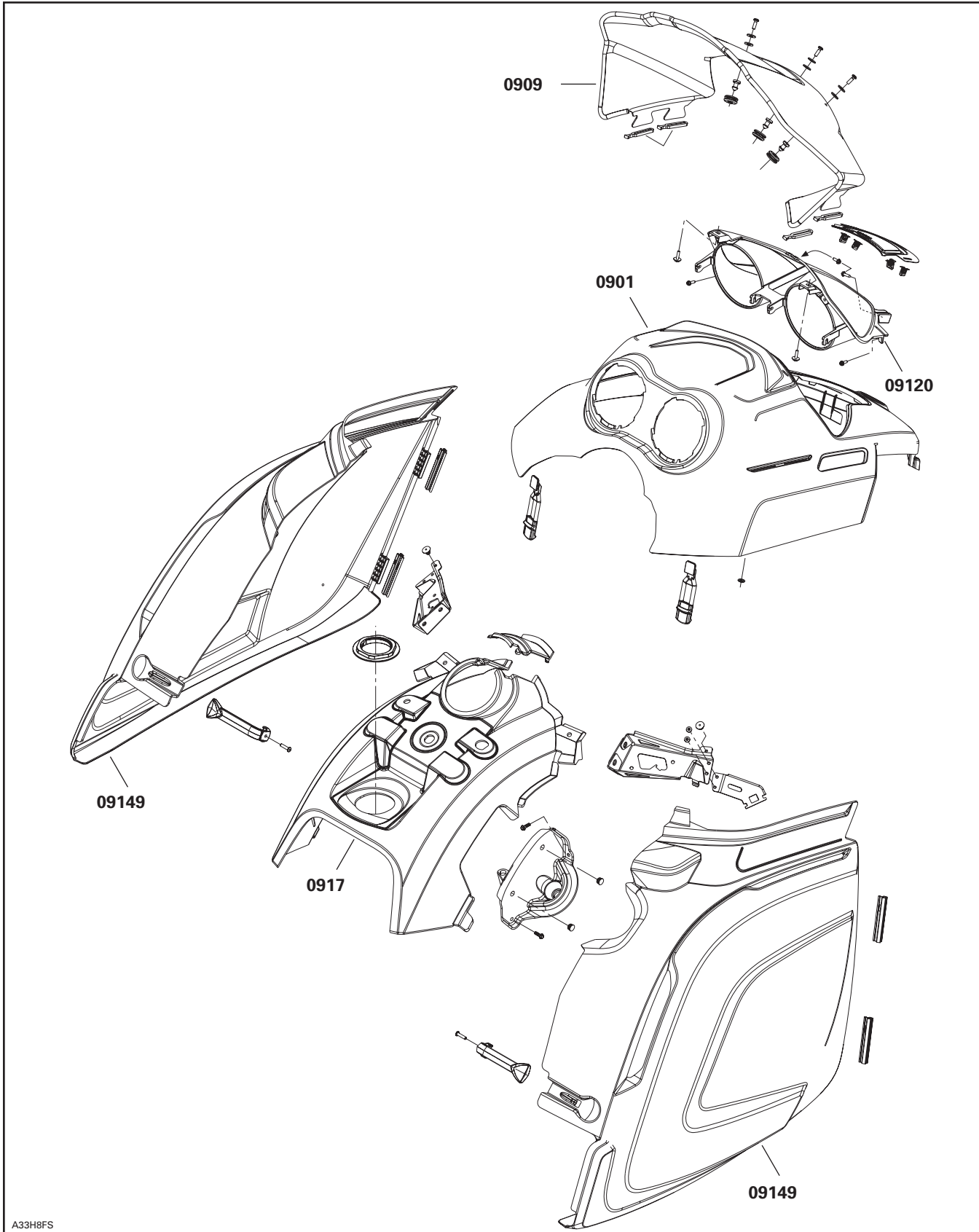

A33H8FS

RF Chassis
Châssis RF

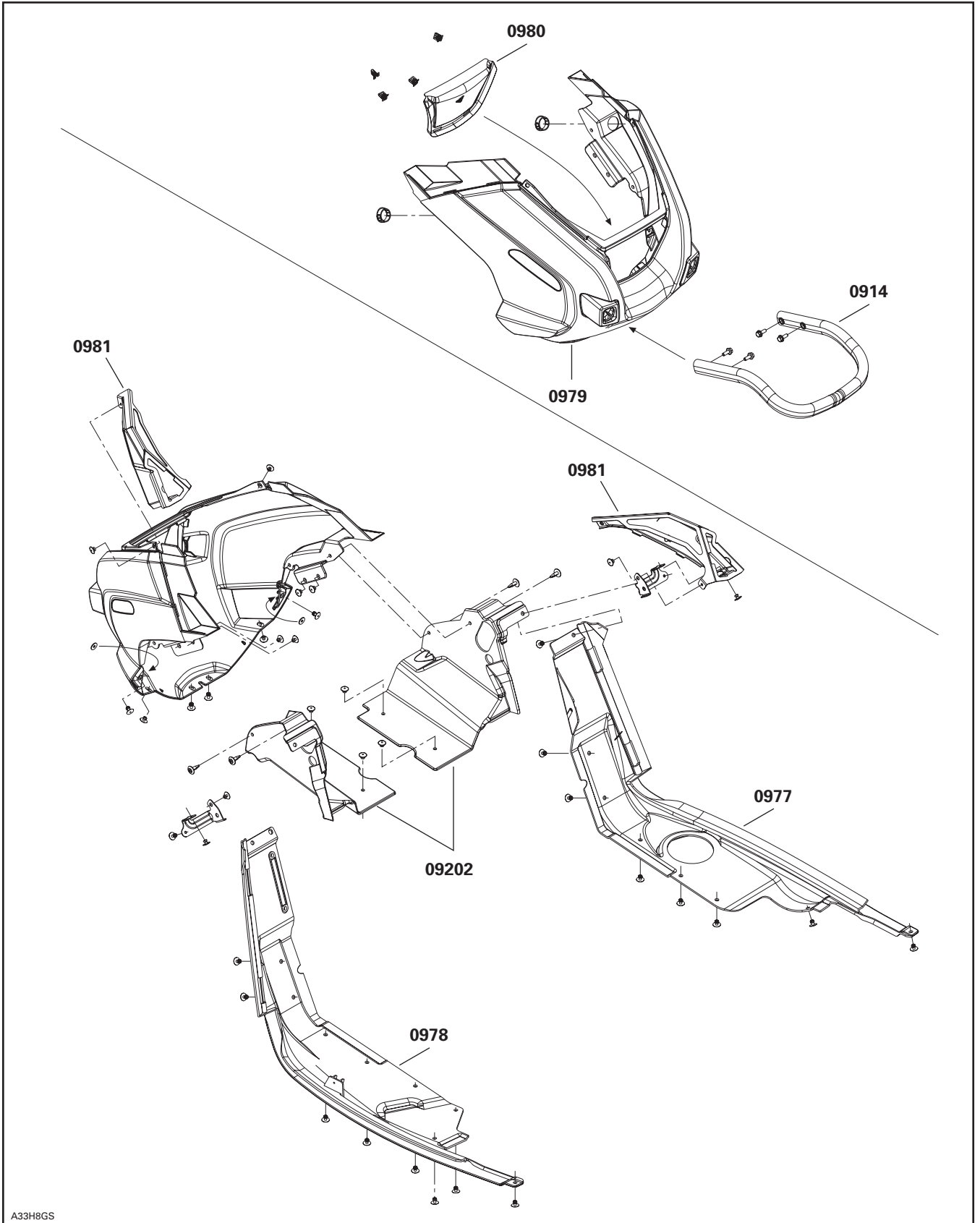

Skandic TUV

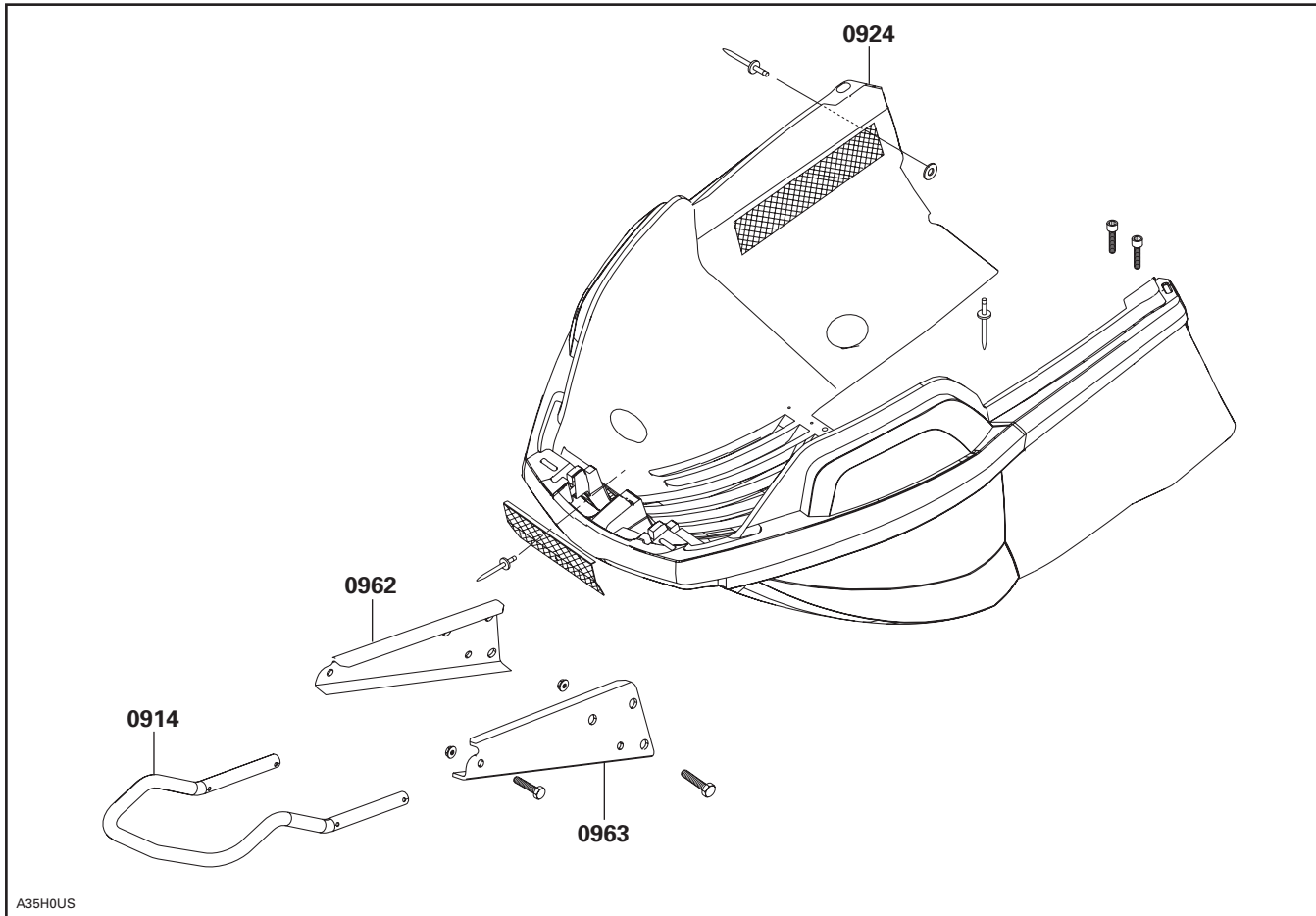

Expedition TUV

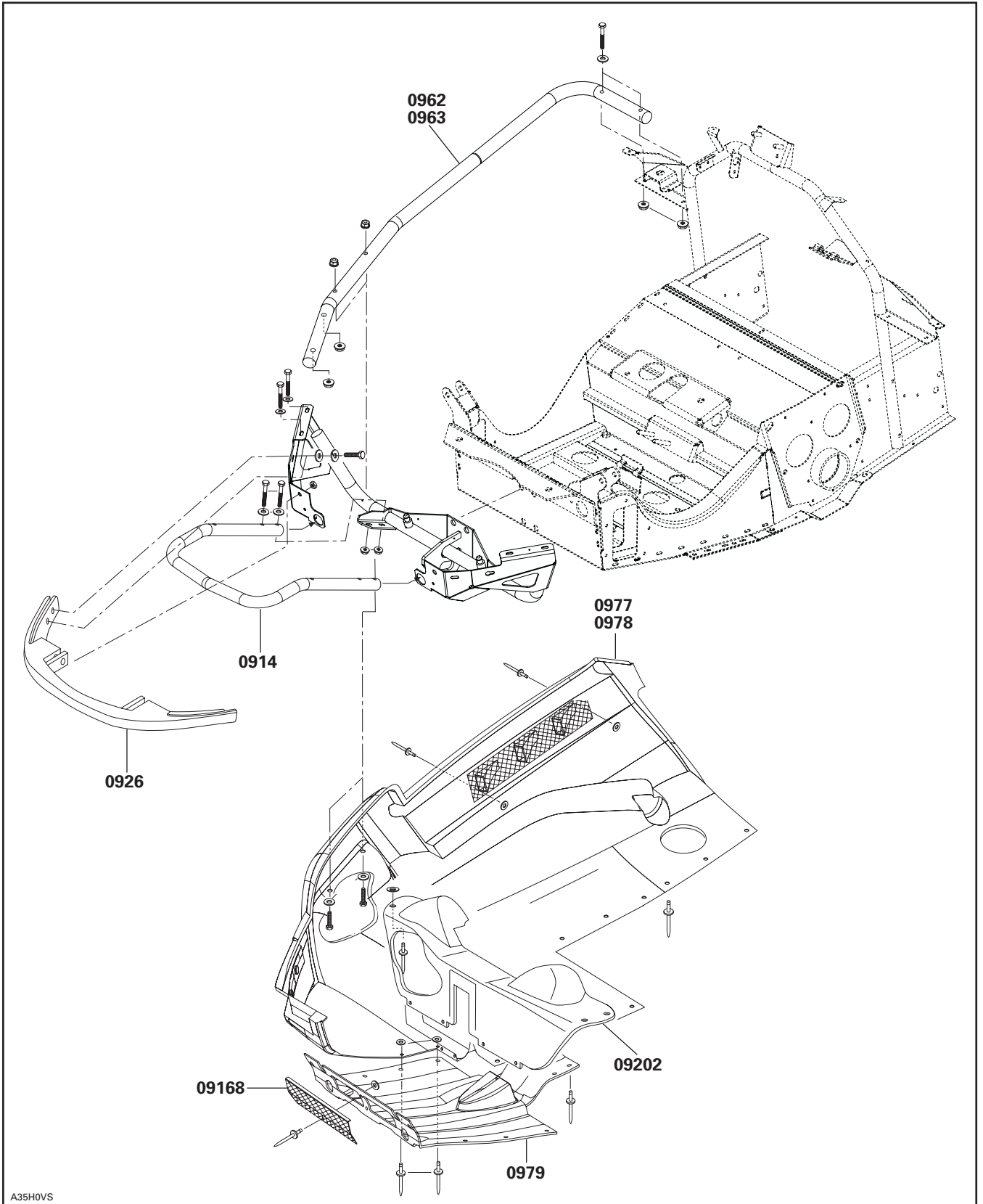

A35H0VS

**RT Chassis
Châssis RT**

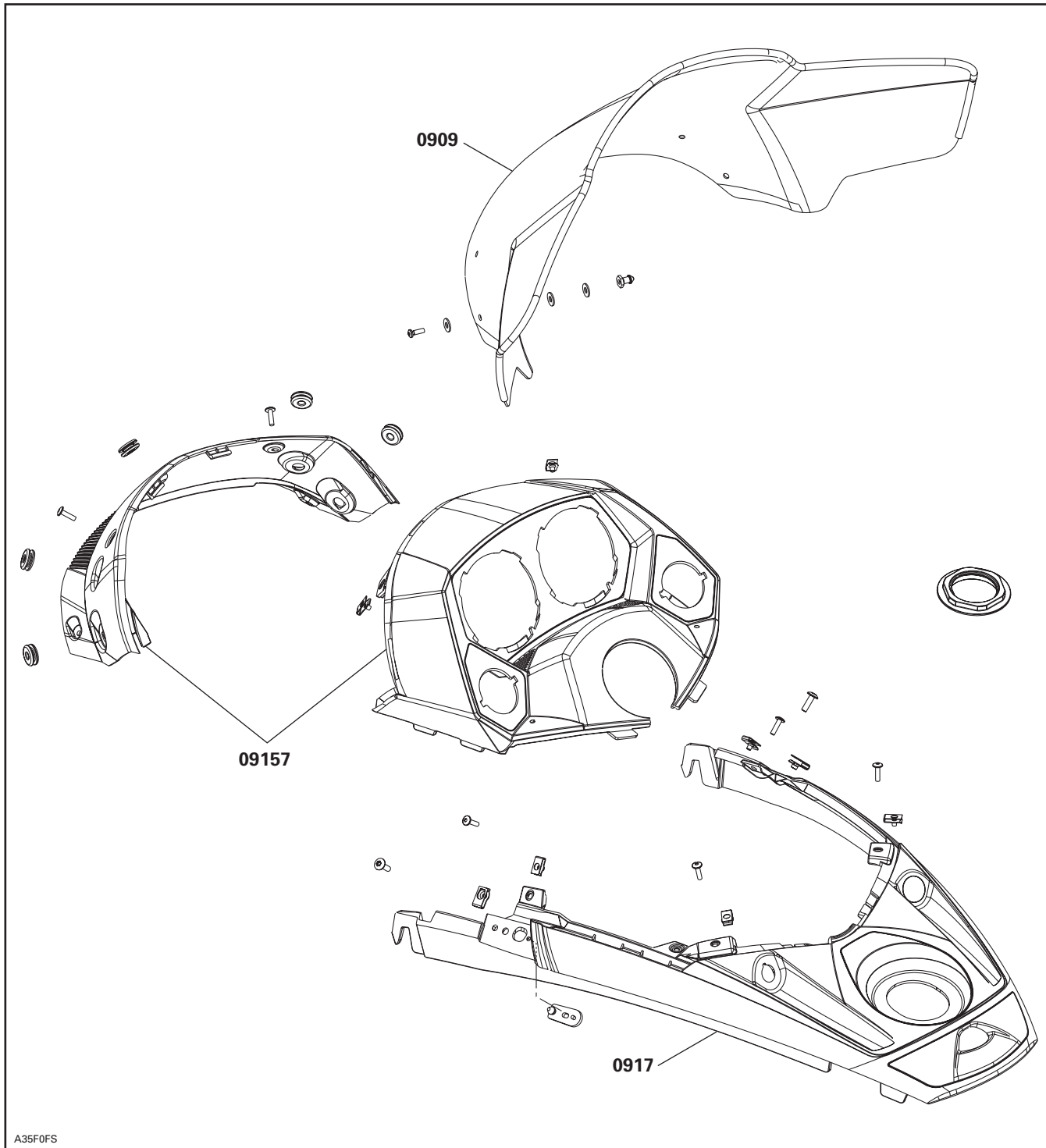

A35F0FS

RT Chassis
Châssis RT

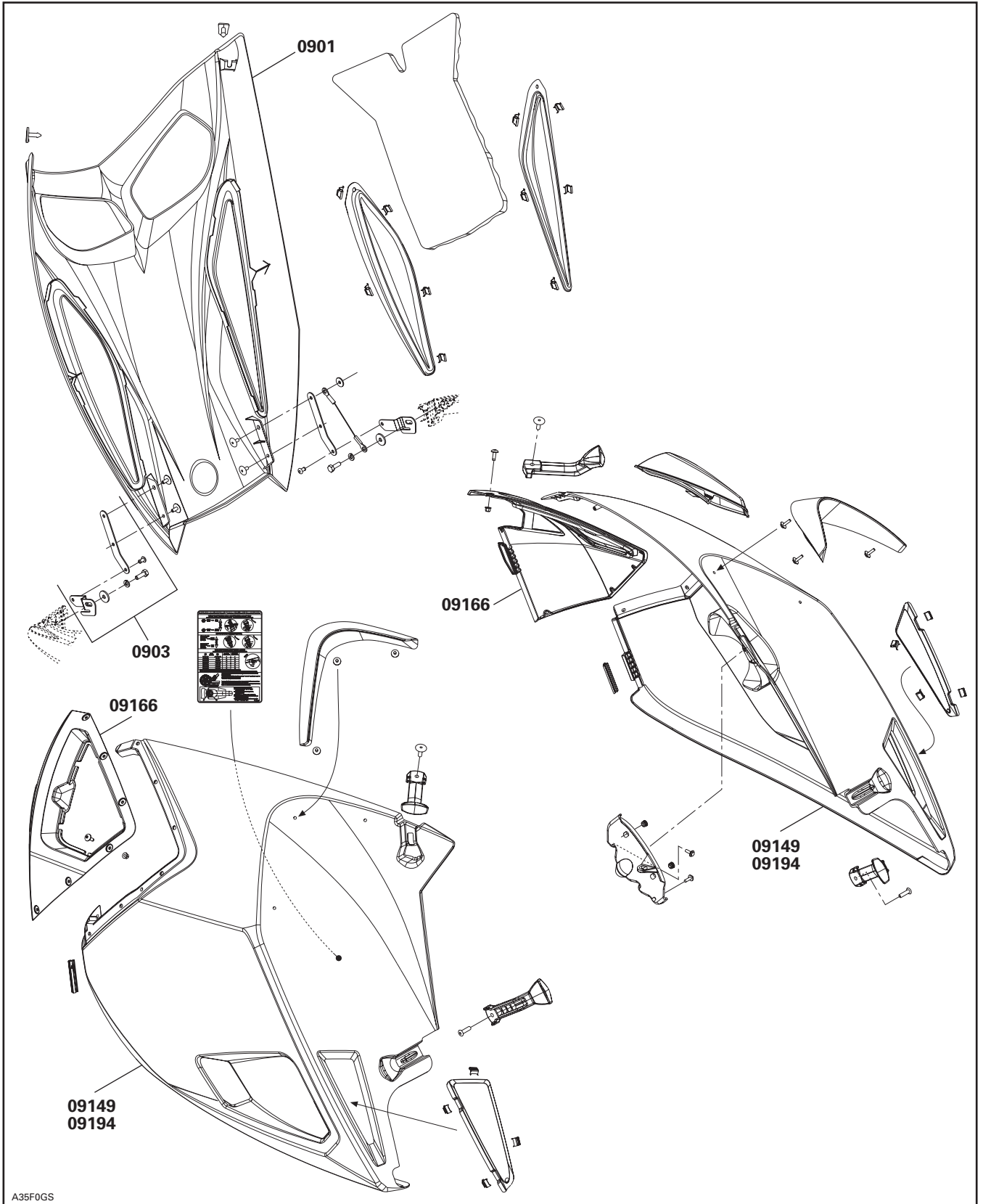

**RT Chassis
Châssis RT**

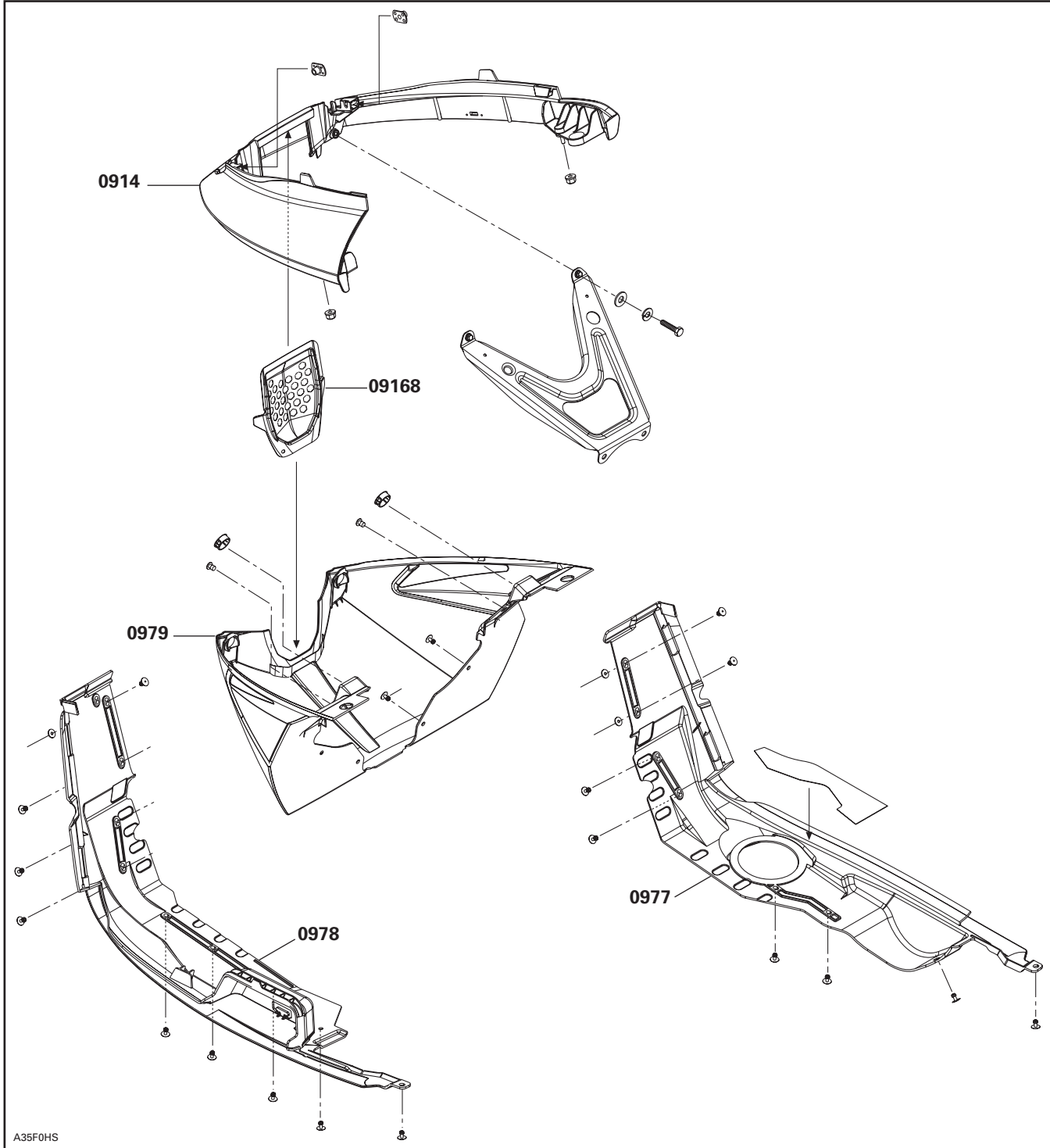

SYSTEM SYSTÈME	CODE	DESCRIPTION	MACH Z/AMX Z 995 SD1	MACH Z/AMX Z 995 SD1 (E)	SUMMIT 995 SD1	SUMMIT 995 SD1 (E)	EXPEDITION SPORT LEGEND TOURING V800	EXPEDITION TUV V800	LEGEND TRAIL TUNDRA V800	SKANDIC SWT V800
			30	31	32	33	34	35	36	37

10	00	NO LABOR INVOLVED AUCUNE MAIN-D'OEUVRE IMPLIQUÉE	0	0	0	0	0	0	0	0
10	01	IGNITION SWITCH INTERRUPTEUR D'ALLUMAGE	0.4	0.4	0.4	0.4	0.4	0.4	0.4	0.4
10	05	BRAKE LIGHT SWITCH INTERRUPTEUR DE FEU D'ARRÊT	0.3	0.3	0.3	0.3	0.3	0.3	0.3	0.3
10	06	TETHER CORD SWITCH OR DESS CAPUCHON COUPE-CIRCUIT OU DESS	0.3	0.3	0.3	0.3	0.3	0.3	0.3	0.3
10	07	IGNITION SWITCH BLOCK LOGEMENT DE RÉCEPTACLE (INTERRUPTEUR)	0.3	0.3	0.3	0.3	0.3	0.3	0.3	0.3
10	08	CURRENT OR GROUND WIRE FIL DE BATTERIE OU DE MASSE	0.3	0.3	0.3	0.3	0.3	0.3	0.3	0.3
10	09	HEADLAMP ASS'Y (ALL PARTS) PHARE COMPLET (TOUTES LES PIÈCES)	0.3	0.3	0.3	0.3	0.3	0.3	0.3	0.3
10	10	VOLTAGE REGULATOR RÉGULATEUR DE TENSION	0.6	0.6	0.6	0.6	0.4	0.5	0.4	0.5
10	12	TAIL LIGHT ASS'Y (ALL PARTS) FEU ARRIÈRE COMPLET (TOUTES LES PIÈCES)	0.4	0.4	0.4	0.4	0.3	0.4	0.3	0.3
10	13	BATTERY RACK, RETAINER ROD AND/OR RETAINER BATTERIE SUPPORT, TIGE DE RETENUE ET/OU COUVERCLE DE RETENUE	0.3	0.3	0.3	0.3	0.3	0.3	0.3	0.3
10	15	HEATED GRIPS POIGNÉES CHAUFFANTES	0.6	0.6	0.6	0.6	0.6	0.6	0.6	0.6
10	16	BULBS (ONE OR ALL) AMPOULES (UNE OU TOUTES)	0.3	0.3	0.3	0.3	0.3	0.3	0.3	0.3
10	17	HEATED THROTTLE LEVER MANETTE D'ACCÉLÉRATEUR CHAUFFANTE	0.3	0.3	0.3	0.3	0.3	0.3	0.3	0.3
10	20	BACK UP BUZZER AVERTISSEUR DE MARCHE ARRIÈRE	0.3	0.3	0.3	0.3	0.3	0.3	0.3	0.3
10	23	HALOGEN BULB AMPOULE HALOGÈNE	0.3	0.3	0.3	0.3	0.3	0.3	0.3	0.3
10	28	SPEEDOMETER OR TACHOMETER (ALL PARTS) INDICATEUR DE VITESSE OU COMPTE-TOURS (TOUTES LES PIÈCES)	0.3	0.3	0.3	0.3	0.3	0.3	0.3	0.3
10	34	ELECTRONIC MODULE MODULE ÉLECTRONIQUE	0.4	0.4	0.4	0.4	0.4	0.6	0.4	0.6
10	44	FUEL GAUGE/TEMPERATURE GAUGE AND COMPONENT INDICATEUR NIVEAU D'ESSENCE/TEMPÉRATURE ET COMPOSANTE	0.3	0.3						

CLAIM TYPE 02 RÉCLAMATION DE TYPE 02

SYSTEM SYSTÈME	CODE	DESCRIPTION	MACH Z/IMX Z 995 SDI	MACH Z/IMX Z 995 SDI (E)	SUMMIT 995 SDI	SUMMIT 995 SDI (E)	EXPEDITION SPORT LEGEND TOURING V800	EXPEDITION TUV V800	LEGEND TRAIL TUNDRA V800	SKANDIC S/WT V800
			30	31	32	33	34	35	36	37
11	00	NO LABOR INVOLVED AUCUNE MAIN-D'OEUVRE IMPLIQUÉE	0	0	0	0	0	0	0	0
11	WT 1	SCHEDULED MAINTENANCE TRACKING SUIVI DES ENTRETIENS PLANIFIÉS	0	0	0	0	0	0	0	0

**FLAT RATE TIME
SUGGESTION**

DEALER'S NO.: _____ DATE: _____

DEALER'S NAME: _____

FILE IDENTIFICATION NO.: _____

ADDRESS: _____

YEAR	MODEL DESCRIPTION	OPERATION	JOB CODE	PRESENT FLAT RATE	SUGGESTED FLAT RATE

Detailed procedure used:

Signature: _____

BOMBARDIER RECREATIONAL PRODUCTS INC.

WARRANTY DEPARTMENT
75, J.A. BOMBARDIER ST.
SHERBROOKE (QUEBEC)
CANADA J1L 1W3

FAX NUMBER: 819-566-3590

**BARÈME DE TEMPS À TAUX FIXE
SUGGESTION**

N° DU CONCESSIONNAIRE: _____ DATE: _____

NOM DU CONCESSIONNAIRE: _____

N° D'IDENTIFICATION DU DOSSIER: _____

ADRESSE: _____

ANNÉE	DESCRIPTION DU MODÈLE	OPÉRATION	CODE DE TRAVAUX	TTP ACTUEL	TTP SUGGÉRÉ

Détails de la marche à suivre:

Signature: _____

BOMBARDIER PRODUITS RÉCRÉATIFS INC.

SERVICE DE GARANTIE
75, RUE J.-A. BOMBARDIER
SHERBROOKE (QUÉBEC)
CANADA J1L 1W3

N° DU TÉLÉCOPIEUR: 819-566-3590