

April 2, 2009

Subject: **GTX[†] LTD iS 255 and RXT™ iS 255**
Predelivery Inspection (All countries)

No. **2009-3**

MODEL	PACKAGE	MODEL NUMBER	ENGINE (HP)	PREDELIVERY KIT	SERIAL NUMBER
GTX [†]	LTD iS	189A	1503 HO (255)	294 000 815	ALL
		189B (Int'l)			
RXT™	iS	349A	1503 HO (255)	294 000 815	ALL
		349B (Int'l)			

GTX[†] is a trademark of Castrol Ltd. Used under license

TABLE OF CONTENTS

	Page		Page
IMPORTANT NOTICE	2	Ending a B.U.D.S. Session	19
UNCRATING	3	ADJUSTMENTS	20
Crate Cover Removal	3	Steering Alignment	20
Vehicle Preparation	3	FUEL SYSTEM PRESSURIZATION	21
Releasing Moving Deck	4	Fuel System Pressurization Procedure	21
PARTS TO BE INSTALLED	6	FINAL INSPECTION	21
Battery	6	Vehicle Test Run	21
Boarding Step	8	Protective Films Removal	21
Steering Column Installation	8	Vehicle Cleaning	21
Steering Cable	11	Delivery to Customer	21
Storage Cover	12	TECHNICAL DATA	22
Compliance Label	12		
Vehicle Decal	12		
Accessories	12		
FLUIDS	12		
General Guidelines	12		
Fuel	12		
Engine Oil	12		
Engine Coolant	14		
B.U.D.S. PROGRAMMING	15		
Connecting a PC to Vehicle	15		
B.U.D.S. Software	16		
D.E.S.S. Key Programming	17		
Information Center Setup	19		
Unlock iS Suspension	19		

IMPORTANT NOTICE

This bulletin must be used in conjunction with the *PREDELIVERY CHECK LIST* enclosed in the shrink pack.

WARNING

To obtain limited warranty coverage, predelivery procedures must be performed by an authorized Sea-Doo watercraft dealer/distributor. Apply all necessary torques as indicated.

— The information and components/system descriptions contained in this document are correct at the time of publication. However, BRP maintains a policy of continuous improvement of its products without imposing upon itself any obligation to install them on products previously manufactured.

— Due to late changes, there might be some differences between the manufactured product and the descriptions and/or specifications in this document. BRP reserves the right at any time to discontinue or change specifications, designs, features, models or equipment without incurring obligation.

— The illustrations in this document show the typical construction of the different assemblies and may not reproduce the full detail or exact shape of the parts; however, they represent parts that have the same or similar function.

— The content of this bulletin is designed as a guideline only. All mechanics performing predelivery procedures should have attended the current model year service training.

— Further information or inquiries should be directed to your distributor service representative and/or specific *SHOP MANUAL* sections.

— Please complete the *PREDELIVERY CHECK LIST* for each watercraft and retain a purchaser signed copy.

— Make sure the purchaser receives the *OPERATORS GUIDE*, *PREDELIVERY CHECK LIST* signed copy and *SAFETY DVD*.

WARNING

Torque wrench tightening specifications must be strictly adhered to. Where specified, install new locking devices (e.g. lock tabs, elastic stop nuts). If the efficiency of a locking device is impaired, it must be renewed.

UNCRATING

Crate Cover Removal

1. Carefully lay crate on its bottom.

NOTICE Allowing crate to drop may cause serious damage to vehicle.

2. Remove all screws retaining crate cover to crate base.

NOTE: Screws that are used are Robertson† #2 type that require the use of an appropriate bit.

3. Assisted by another person, lift up crate cover.

4. Raise cover vertically from both ends at the same time.

NOTICE Never tip cover toward the front or rear of the vehicle while lifting it.

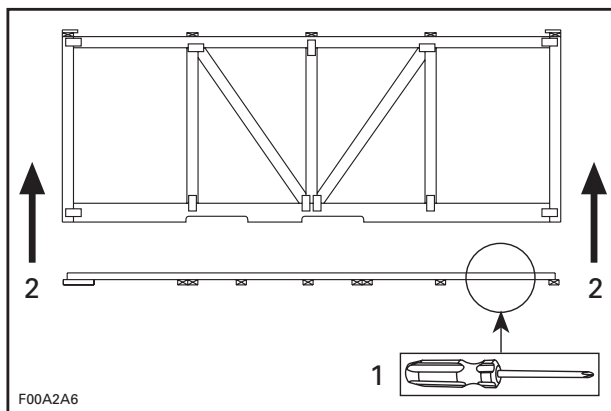

TYPICAL

1. Remove screws
2. Raise cover vertically

Vehicle Preparation

1. Remove rear retaining screws from crate base.

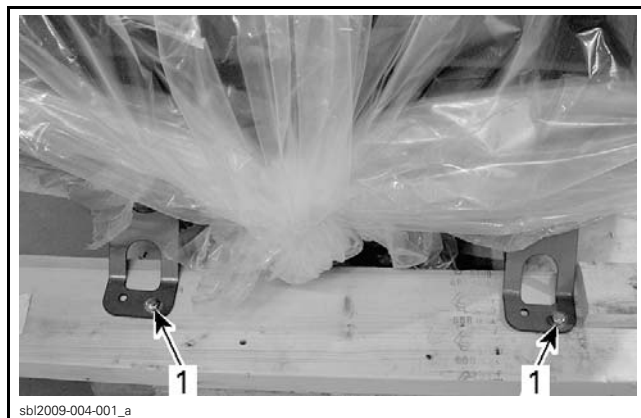

1. Rear retaining screws

2. Cut front retaining strap.

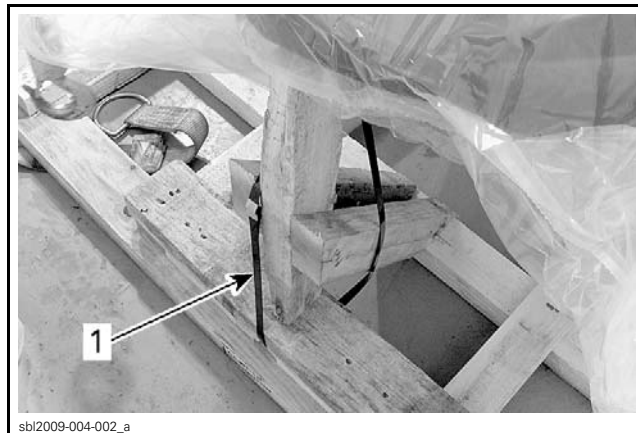

1. Front retaining strap

3. Remove protective wrapping from vehicle.

NOTICE While manipulating to cut, take care not to damage trim components with blade.

4. Lift vehicle using the LIFTING STRAP (P/N 529 036 171).

NOTICE Using any other lifting strap kit than the recommended one will cause damages to the vehicle. Bumpers will be tear off and their replacement will be required.



5. Place the vehicle on a proper support.

6. Remove rear retaining bracket from vehicle.

6.1 Discard brackets and screws.

6.2 Keep washers for boarding step installation.

† Robertson is a registered trademark of Robertson Inc.

NOTE: If washers are not present, you will need 6 stainless steel flat washer (P/N 234 061 600).

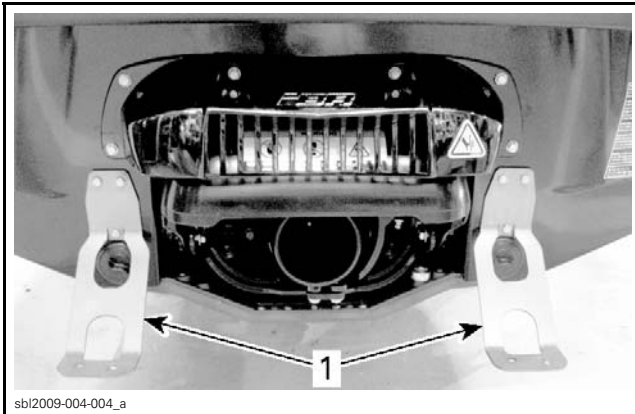

1. Rear retaining brackets

USA and Canadian models

7. Remove boarding step from vehicle by cutting locking ties.

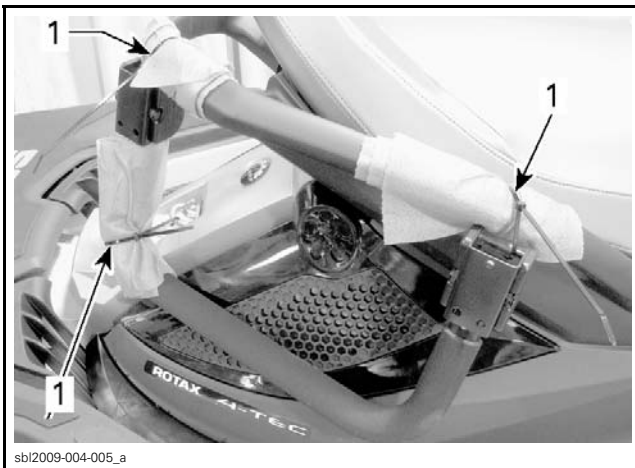

1. Locking ties

International Models

Remove the gauge support cover then cut locking ties to release the boarding step.



1. Gauge support cover

All Models

8. Ensure that the predelivery kit in the storage compartment includes the following items.

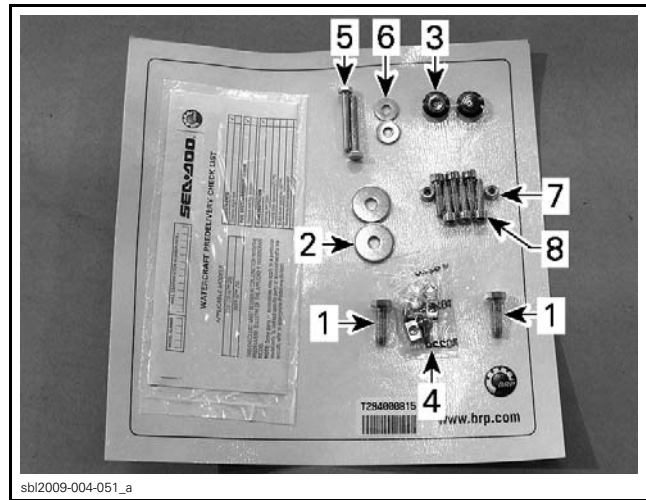

ITEM	DESCRIPTION (P/N)	QTY
1	M8 x 25 screw (P/N 207 382 560)	2
	Refer to <i>RELEASING MOVING DECK</i> subsection.	
2	M8 washer (P/N 250 200 011)	2
	Refer to <i>RELEASING MOVING DECK</i> subsection.	
3	Plastic cap (P/N 291 002 950)	2
	Refer to <i>RELEASING MOVING DECK</i> subsection.	
4	Battery hardware (P/N 250 000 282)	1
	Refer to <i>BATTERY</i> subsection.	
5	M6 x 45 bolt (P/N 207 164 560)	2
	Refer to <i>BATTERY</i> subsection.	
6	M6 washer (P/N 234 062 600)	2
	Refer to <i>BATTERY</i> subsection.	
7	M6 nut (P/N 232 561 200)	2
	Refer to <i>BATTERY</i> subsection.	
8	M6 x 25 screw (P/N 250 000 076)	6
	Refer to <i>BOARDING STEP</i> subsection.	

Releasing Moving Deck

NOTE: For transportation purpose, the moving deck suspension has been completely compressed and secured at the factory using cable. Make sure to release tension and remove securing cable from moving deck suspension prior to working on the vehicle.

⚠ WARNING

The moving deck suspension is attached under tension (spring-loaded). Before releasing tension:

- Clean moving deck of any objects and tools.
- Do not use pneumatic or electric tools for removing moving deck retaining screws.
- Adhere strictly to following procedure.

1. Lift seat by pressing the rear latch and moving seat to the rear and them upwards.

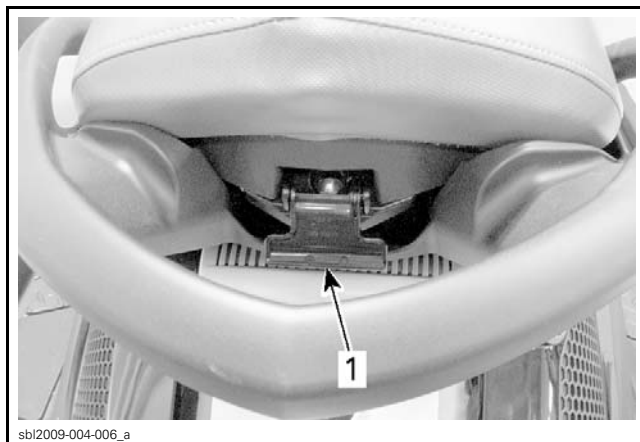

1. Rear latch

2. Remove cable free end from hole.
3. Put a knot at the end of the cable to prevent it from going into the hole.

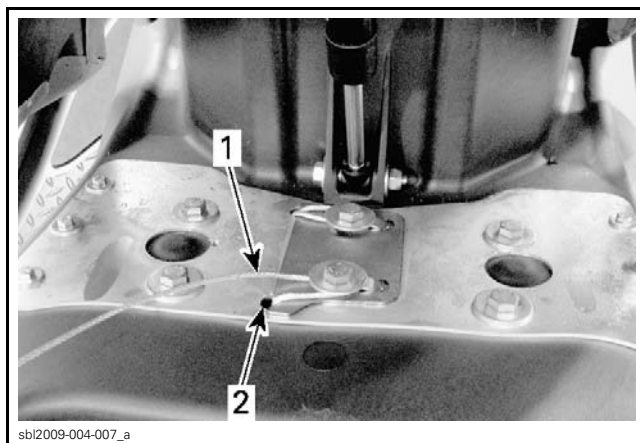

1. Cable free end
2. Hole

4. **Slowly** unscrew rear retaining screw (Do not use pneumatic or electric tools).

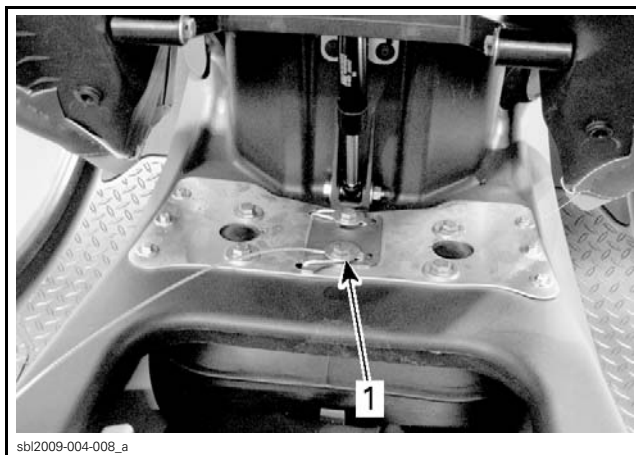

1. Rear retaining screw

5. **Carefully** lift rear tab upwards using a flat screwdriver.



1. Rear tab

NOTE: After lifting the rear tab, the cable will slide into the hole and the moving deck will move upwards. Ensure that the cable is free of tension before removing the front screw.

6. Remove front retaining screw.

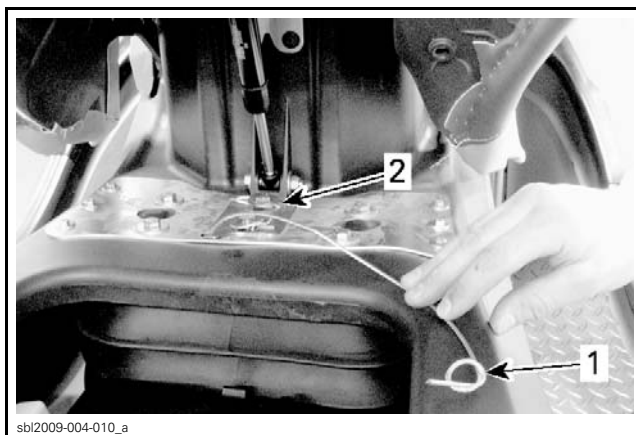

1. Knot
2. Front retaining screw

PARTS TO BE INSTALLED

7. Completely remove and discard the following items from moving deck.

- Cable
- Retaining screws
- Washers
- Plate.

8. Install plastic caps on moving deck (from pre-delivery kit).

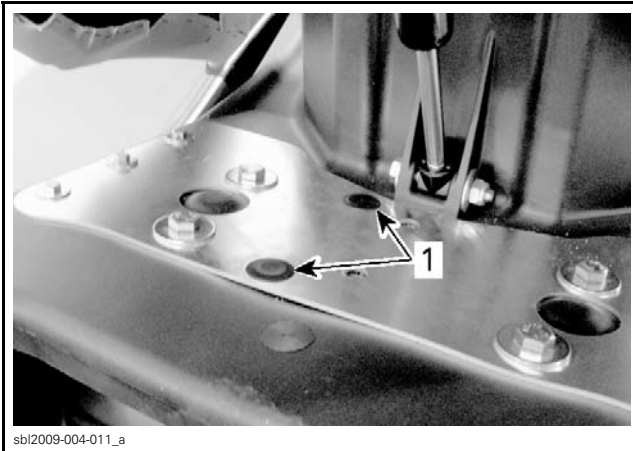

1. Plastic caps

9. Install M8 x 25 screws and M8 washers on moving deck (from pre-delivery kit).

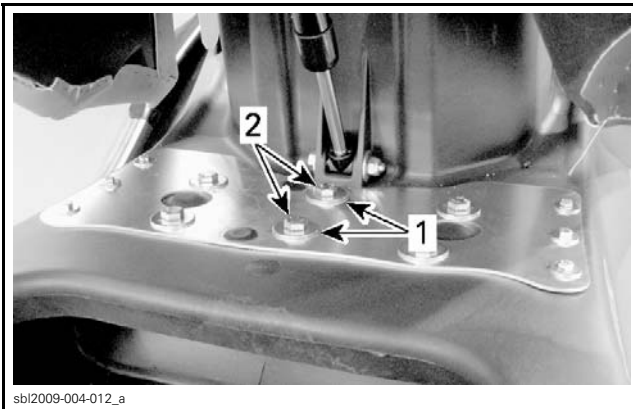

1. M8 washers
2. M8 x 25 screws

10. Tighten screws to 25 N•m (18 lbf•ft).

PARTS TO BE INSTALLED

Battery

⚠ WARNING

Never charge or boost battery while installed in watercraft.

NOTICE Always charge battery before its installation on the vehicle.

NOTICE Make sure not to squeeze battery cables between vehicle components.

Battery Removal

1. Open the boarding platform.

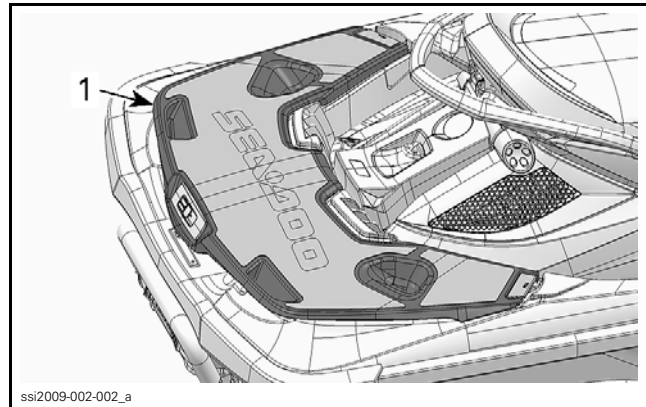

1. Boarding platform

2. Remove the RH (starboard) storage bin.

NOTE: The storage bin is secured using two plastic rivets

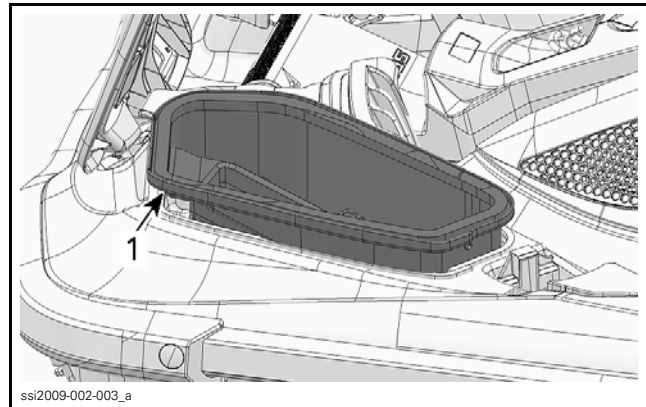

1. RH (starboard) storage bin

3. Disconnect the diagnostic connector.

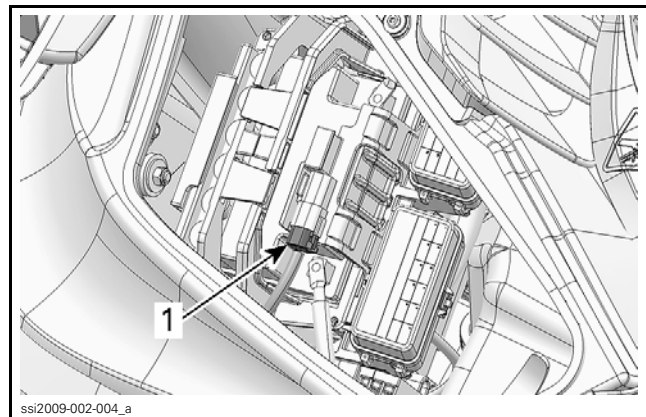

1. Diagnostic connector

4. Lift and push the top of electrical component support forward to unlock it from battery holder.

5. Move support aside to make room.

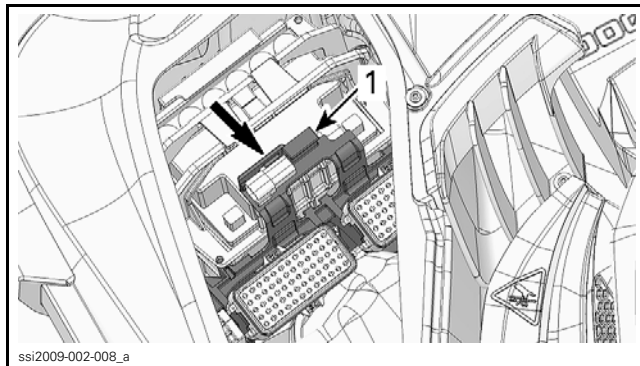

1. Electrical component support

6. Remove and discard screws securing battery holder to battery holder base (one on each side).

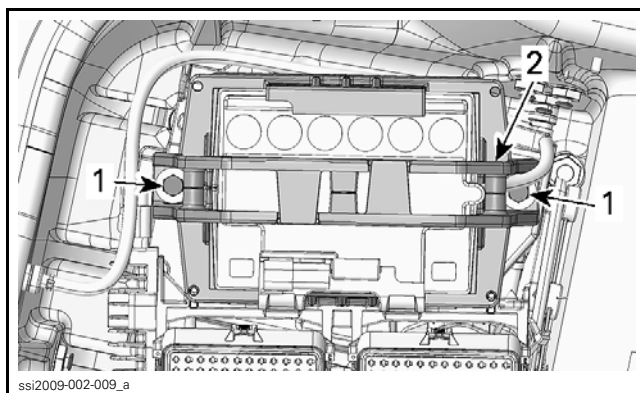

PARTS REMOVED FOR CLARITY

1. Retaining screws
2. Battery holder

7. Unplug vent hose from battery.

8. Remove battery holder from vehicle.

9. Remove battery from battery holder.



Battery Activation and Charging

1. Activate and charge the battery.

Refer to the latest edition of *Sea-Doo BATTERIES ACTIVATION, CHARGING AND MAINTENANCE BULLETIN* and to instructions notice attached to battery for proper activating, charging and maintenance procedure.

Battery Installation

⚠ WARNING

Always connect battery cables exactly in this specific order. Connect RED positive cable first, then BLACK negative ground cable.

1. Install charged battery into battery holder.
2. Secure battery on battery holder using the following hardware from predelivery kit:
 - M6 x 45 bolts
 - M6 flat washers
 - M6 nuts.

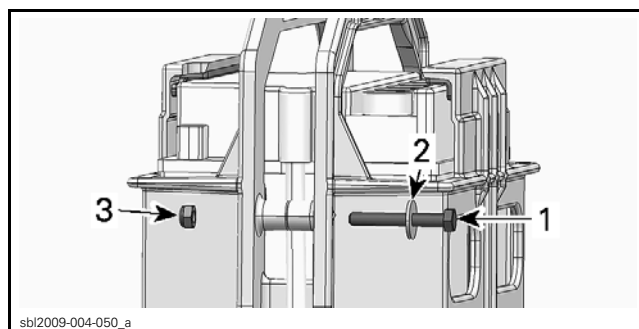

1. M6 x 45 bolt
2. M6 flat washer
3. M6 nut

3. Tighten bolts to 5 N•m (44 lbf•in).
4. Position battery holder on vehicle.
5. Plug vent hose on the top of battery.
6. Make sure vent hose is not pinched or bent.
7. Reinstall screws securing battery holder to battery holder base (one on each side).
8. Tighten battery holder screws to 14 N•m (124 lbf•in).
9. Attach the electrical component support to battery holder.
10. Insert diagnostic connector into its housing.
11. Apply DIELECTRIC GREASE (P/N 293 550 004) on battery posts.
12. Connect RED (+) battery cable then BLACK (-) cable using the battery hardware (from predelivery kit).

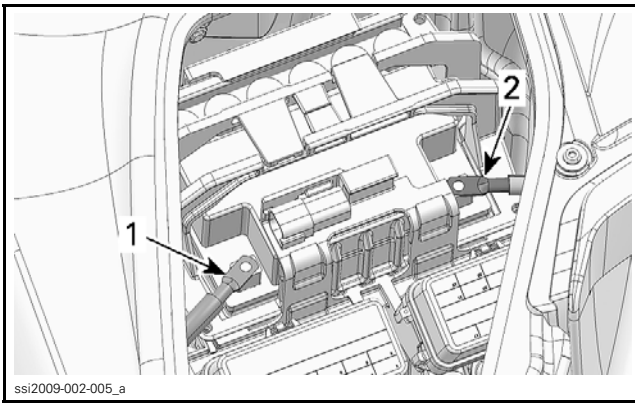

1. BLACK (-) cable
2. RED (+) cable

13. Cover positive battery post with rubber boot. Do not install the storage bin yet. It's removal is necessary to connect B.U.D.S..

⚠ WARNING
Ensure vent tube is not kinked or obstructed. Battery vent tube must be properly installed and secured with a locking tie.

Boarding Step

1. Position boarding step on fixation holes.



1. Boarding step fixation holes

2. Install M6 washers (previously removed from retaining brackets).
3. Install M6 x 25 screws (from predelivery kit).
4. Torque M6 screws to 10 N•m (89 lbf•in).

NOTE: For an easier installation, place small shafts into the housing cavities to lock the boarding step downwards.

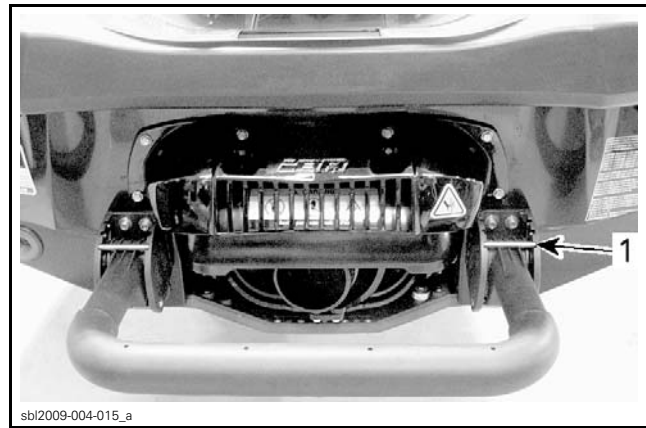

1. Small shaft

Steering Column Installation

International Models

1. Cut retaining strap that holds front storage cover to vehicle.

NOTICE

- Properly hold the front storage cover with hand while cutting the retaining strap.
- Be careful not to damage vehicle components while cutting.



1. Front storage cover
2. Retaining strap

2. Cut locking tie securing front storage cover to vehicle.
3. Carefully remove the cover from vehicle.



1. Locking tie

4. Remove foam from storage cover.
5. Cut locking tie that holds gas shock to storage cover.

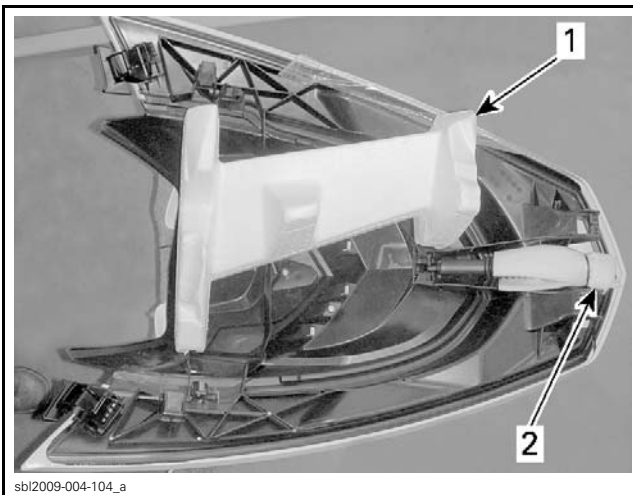

1. Foam
2. Gas shock

6. Remove retaining collar from hood.

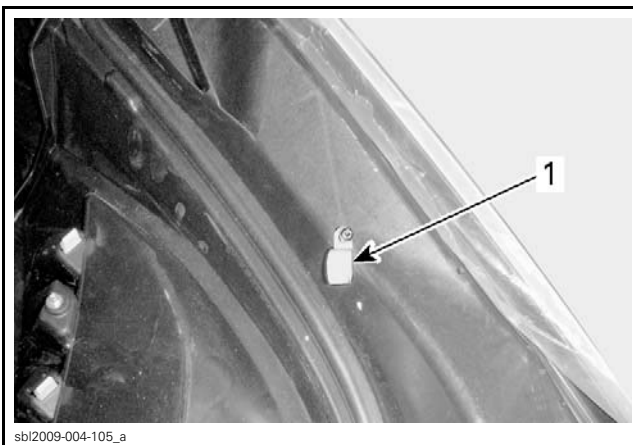

1. Retaining collar

7. Disconnect gauge connector.
8. Disconnect steering connectors from vehicle harness.

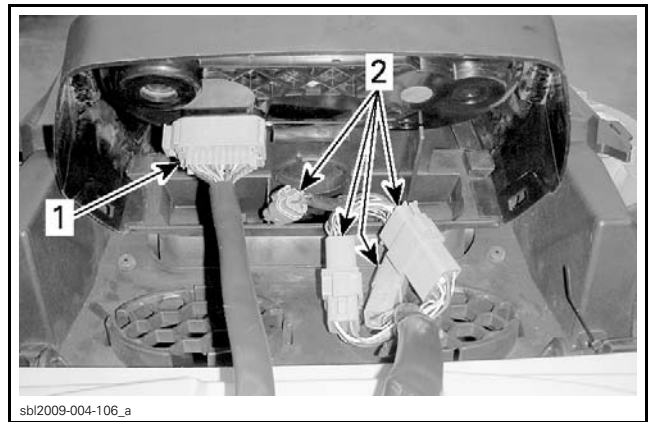

1. Gauge connector
2. Steering connectors

9. Remove gauge support by lifting it upwards using a screwdriver.

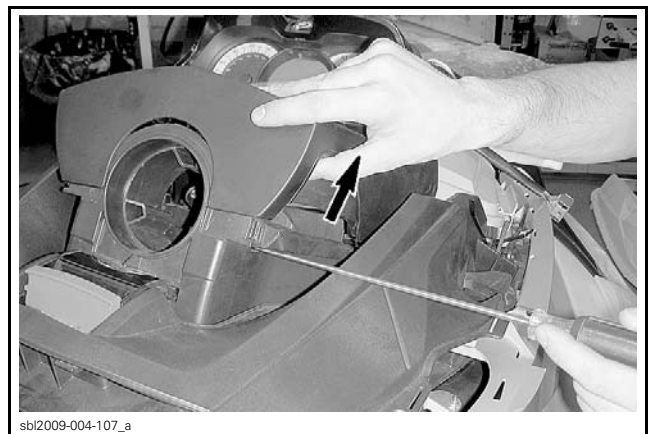

10. Cut retaining strap that holds steering column.
11. Carefully remove steering column from foam.

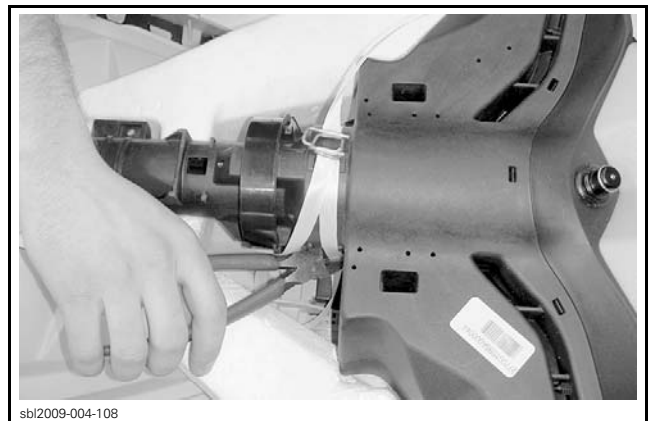

12. Remove foam from vehicle.
13. Remove front storage bin from vehicle.

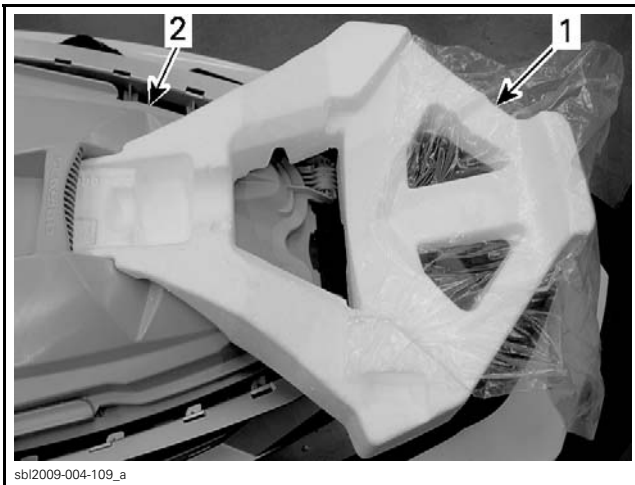

1. Steering column foam
2. Front storage bin

14. By the front storage compartment opening, pull vehicle harness connectors through front module opening to locate them between the fixed deck and the moving deck.
15. Remove screws and washers from the steering column arm. Keep them for reuse.
16. Remove tape retaining the steering column arm.

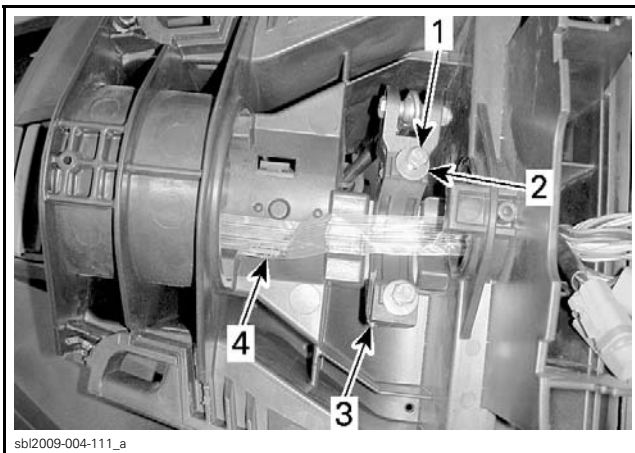

1. Steering column retaining screw
2. Washer
3. Steering column arm
4. Tape

17. Ensure upper and lower wear bushings are properly inserted into steering support.

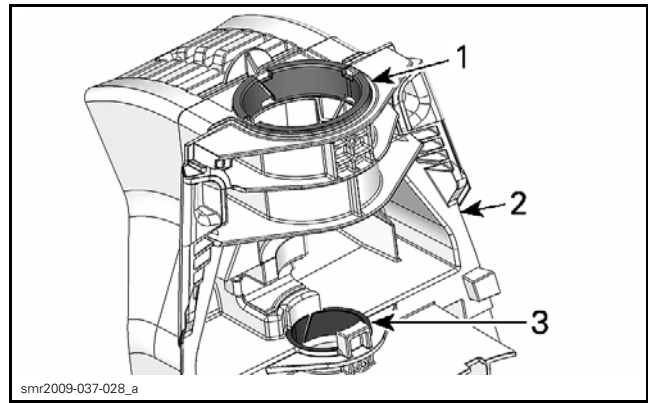

1. Upper bushing
2. Steering column support
3. Lower bushing

18. Carefully, drive steering column through steering column support. Ensure to not hit the O.T.A.S. magnet during steering column installation.

19. Insert steering harness through the front module opening.

NOTE: Do NOT insert gauge connector into front module opening.

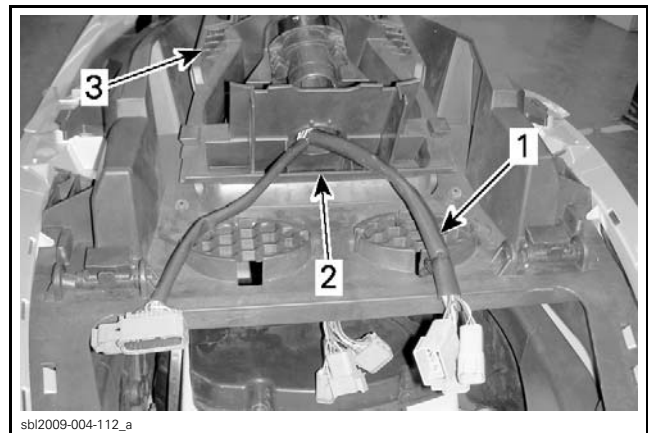

1. Steering harness
2. Front module opening
3. Steering support

20. Complete insertion of the steering column into its support.

21. Install steering retaining screws and washers (previously removed) onto bracket holes.

22. Tighten steering column screws to 6 N•m (53 lbf•in).

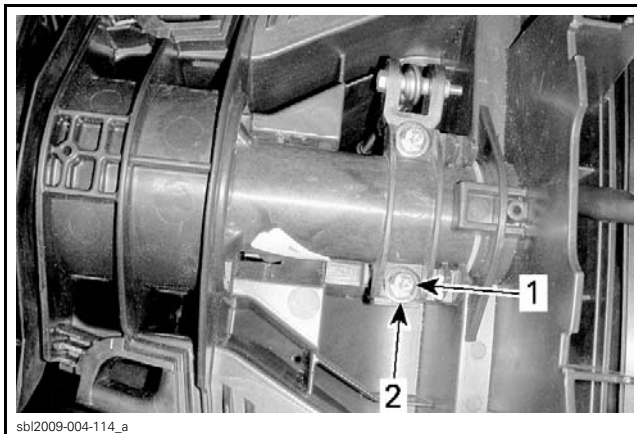

1. Steering column screw
2. Steering washer

23. Install gauge support by pushing it downwards. Make sure to engage front and rear locking tabs.



24. From inside storage compartment, connect steering connectors to vehicle harness.

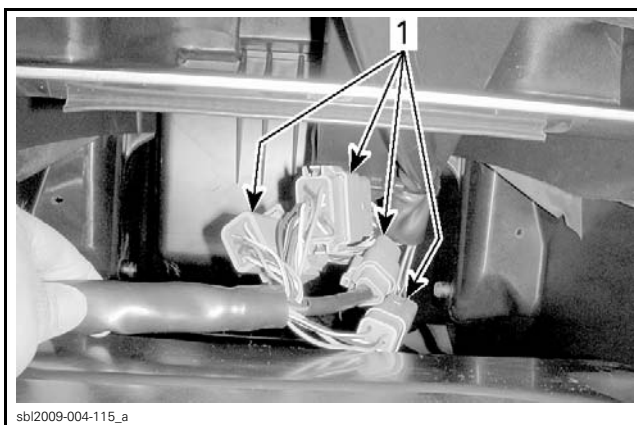

1. Steering connectors

25. Connect gauge connector.

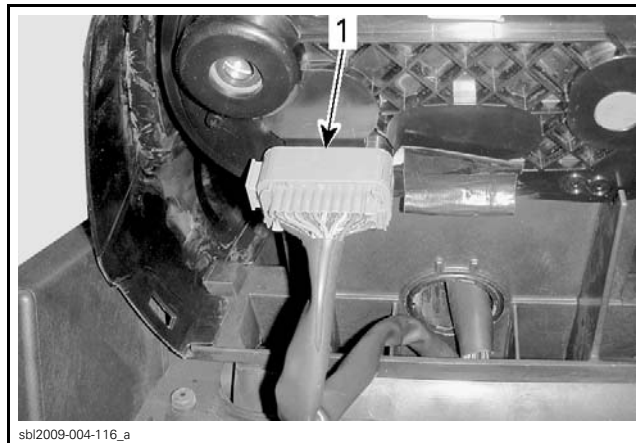

1. Gauge connector

26. Install gauge support cover.

26.1 Soften the bottom portion of cover using an incandescent or halogen light.

26.2 First, insert the top of the cover.

26.3 Press both lower sides of cover to lock tabs.



Steering Cable

International Models

1. Verify if steering cable is properly installed into its support.
2. Perform steering alignment procedure, described further in this bulletin, prior to torquing screws from steering cable supports.

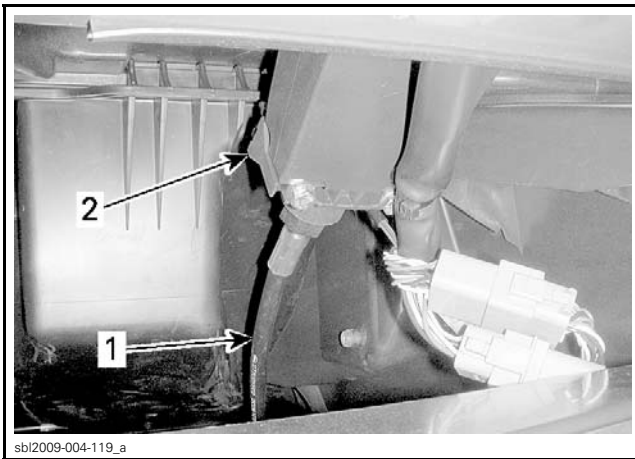

1. Steering cable
2. Steering cable support

NOTICE Steering alignment procedure, described further in this bulletin, must be performed prior to torquing screws from steering cable supports.

Storage Cover

International Models

1. Install front storage cover on vehicle front hinges.
2. Position the gas shock lower attachment on cavity opening.

NOTICE To avoid breaking the attachment, do not force to insert it in cavity.

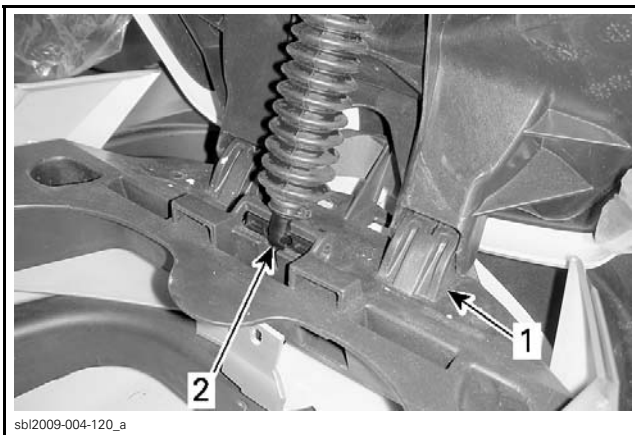

1. Front hinge
2. Shock absorber lower attachment point

Close cover to lock the bottom of the gas shock.

Compliance Label

For Watercraft Sold in Canada

Install Canadian Coast Guard compliance label as per local legislation.

For Watercraft Sold in California

Install mandatory CO warning label as per local legislation.

For Watercraft Sold in Australia

Install Australian boat plate as per local legislation.

Vehicle Decal

1. Install decals on vehicle according to customer country language and local legislation.
2. Ensure that the new decals are installed at the same location and over the factory installed decals.

Accessories

1. Install accessories (if any) as per their installation instructions (included in each kit).
2. Install any other equipment required by law (if any).

FLUIDS

General Guidelines

All fluids (except fuel) have already been filled at factory, it is only necessary to validate them.

Fuel

WARNING
Never add fuel prior to checking fuel line connector tightness.

WARNING
Fuel is flammable and explosive under certain conditions. Always work in a well ventilated area.

NOTICE Never add oil in fuel. Never use fuel containing more than 10% alcohol (ethanol or methanol).

1. Verify fuel line connectors prior to powering-up ECM. This verification must be done visually as well as manually by physically checking each connection.
2. Add fuel in the fuel reservoir. Refer to *SPECIFICATION TABLE*.

Engine Oil

Recommended Engine Oil

Use XPS SUMMER GRADE OIL (P/N 293 600 121).

If XPS™ engine oil is not available, use a 10W40 mineral engine oil compatible with wet clutches.

NOTE: The XPS engine oil has been thoroughly tested to be free of any additives that could impair the functionality of the supercharger clutch.

NOTICE NEVER use synthetic oil. This would impair the proper operation of the supercharger clutch. Do not add any additives to the recommended oil. Mineral oils not recommended by BRP may also contain additives (friction modifiers) that may cause inappropriate slippage of the supercharger and eventually lead to premature wear. For this reason, XPS Summer Grade oil or a BRP approved equivalent are the only recommended oils. Use of any oil not recommended by BRP may void BRP's limited warranty.

Engine Oil Level Verification (Watercraft Out of Water)

NOTE: Oil level can be checked with watercraft either in or out of water.

NOTICE Check oil level frequently and refill if necessary. Do not overfill. Operating the engine with an improper level may severely damage engine.

⚠ WARNING
 Certain components in the engine compartment may be very hot. Direct contact may result in skin burn.

⚠ WARNING
 When operating the engine out of water, the heat exchanger in the ride plate may become very hot. Avoid any contact with the ride plate as burns may occur.

1. Place vehicle level.

NOTE: The watercraft is level when it is in water. When on a trailer, raise trailer tow pole and block in this position when bumper rail is level.

2. Open seat and remove the rear ventilation box from the deck extension to gain partial access to engine compartment.

NOTE: To remove the ventilation box, simply release the 3 clips retaining it and lift it off the deck extension.

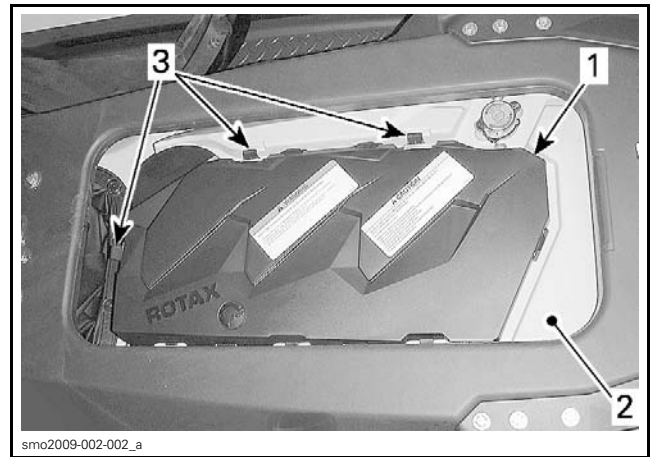

1. Ventilation Box
 2. Deck Extension
 3. Retaining clips

3. Install a garden hose on the exhaust system flushing connector. Refer to *FLUSHING* in *POST-OPERATION CARE* subsection in the *OPERATOR'S GUIDE* and follow the procedure.

NOTICE

- Never run engine without supplying water to the exhaust system. Failure to cool exhaust system may severely damage it.
- Never run engine longer than 2 minutes. Drive line seal has no cooling when watercraft is out of water.

4. With the engine already at normal operating condition, let engine idle for 30 seconds then stop engine.

5. Wait at least 30 seconds for the oil to settle in the engine, then pull dipstick out and wipe clean.

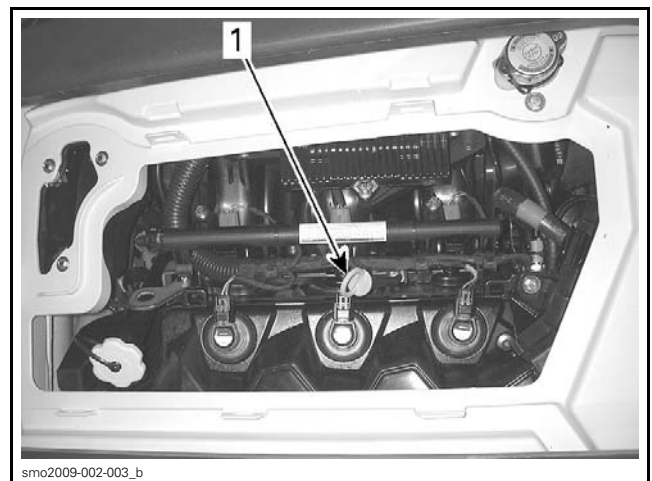

1. Oil dipstick

6. Reinstall dipstick, push in completely.

7. Remove dipstick again and read oil level. It should be between the FULL and ADD marks.

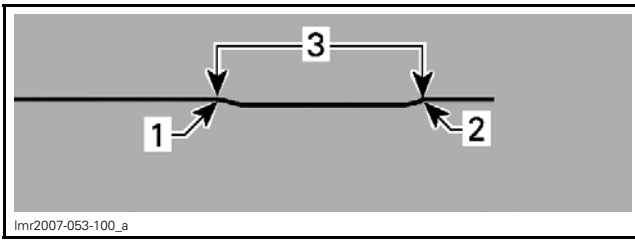

1. Full
2. Add
3. Operating range

8. Add oil to ensure the level is between marks as required.
9. To add oil, remove the oil cap.
10. Place a funnel in the oil filler neck opening.
11. Add the recommended oil to the proper level.

NOTE: Do not overfill.

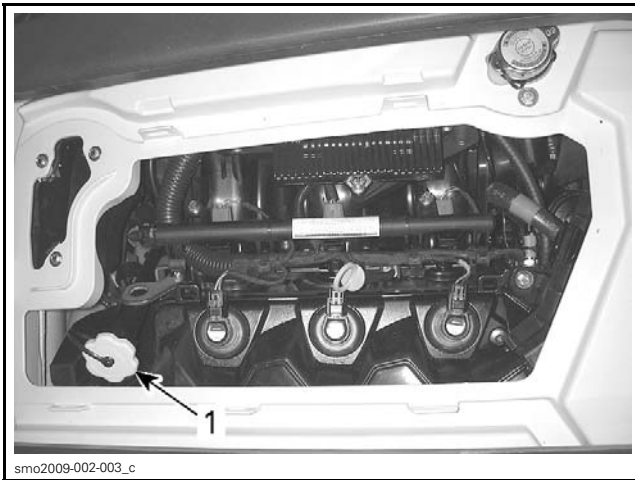

1. Oil filler cap

NOTE: Every time oil is added in the engine, the complete procedure previously explained must be carried out (engine restarted, idling for 30 seconds the shut off, wait 30 seconds then recheck the oil level). Otherwise, you will obtain a false oil level reading.

12. Properly reinstall oil cap and dipstick.

Engine Coolant

Recommended Engine Coolant

Always use ethylene-glycol antifreeze containing corrosion inhibitors specifically for internal combustion aluminum engines.

NOTE: When available, it is recommended to use biodegradable antifreeze compatible with internal combustion aluminum engines. This will contribute to protect the environment.

Cooling system must be filled with water and antifreeze solution (50% demineralized water, 50% antifreeze) or use the BRP PREMIXED COOLANT (P/N 219 700 362).

NOTE: Using a blend of 40% antifreeze with 60% demineralized water will improve the cooling efficiency when watercraft is used in particularly hot weather and/or hot water condition.

Engine Coolant Level Verification

⚠ WARNING

Check coolant level with engine cold. Never add coolant in cooling system when engine is hot.

⚠ WARNING

Certain components in the engine compartment may be very hot. Direct contact may result in skin burn.

1. Place vehicle level.

NOTE: The watercraft is level when it is in water. When on a trailer, raise trailer tow pole and block in this position when bumper rail is level.

2. Open seat.
3. Remove the rear ventilation box. Refer to *ENGINE OIL LEVEL* for the procedure.
4. Locate the expansion tank cap.

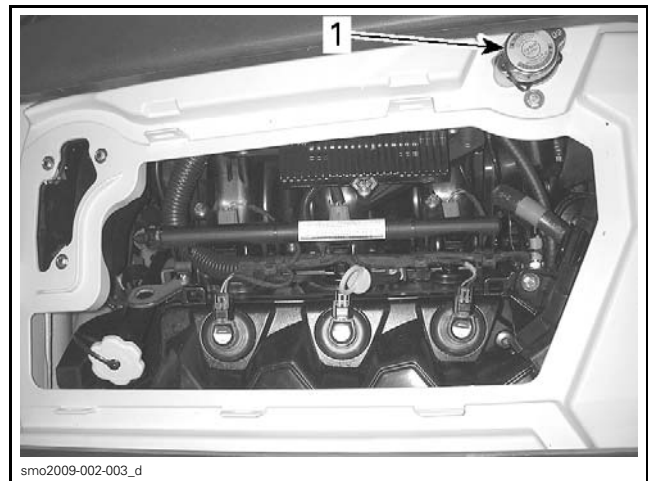

TYPICAL
1. Expansion tank cap

5. With vehicle on a level surface, coolant level should be between MIN. and MAX. marks on coolant reservoir when engine is cold.

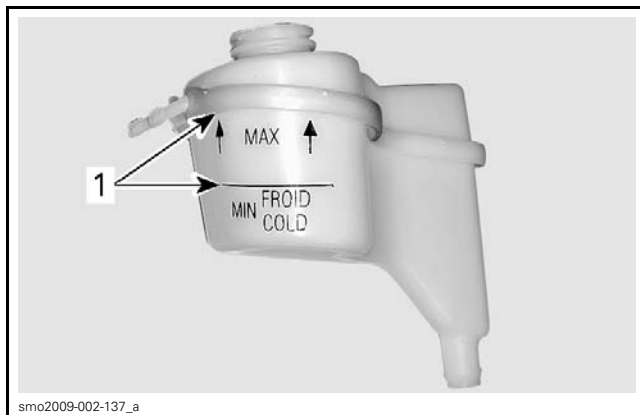

TYPICAL - COOLANT EXPANSION TANK
 1. Level between marks when engine is cold

6. Adjust coolant level between marks as required. Use a funnel to avoid spillage. Do not overfill.
7. Properly reinstall and tighten filler cap, then re-install ventilation box and close seat.

B.U.D.S. PROGRAMMING

Connecting a PC to Vehicle

⚠ WARNING

If the computer you are using is connected to the power outlet, there is a potential risk of electrocution when working in contact with water. Be careful not to touch water while working with the computer.

Open the boarding platform.

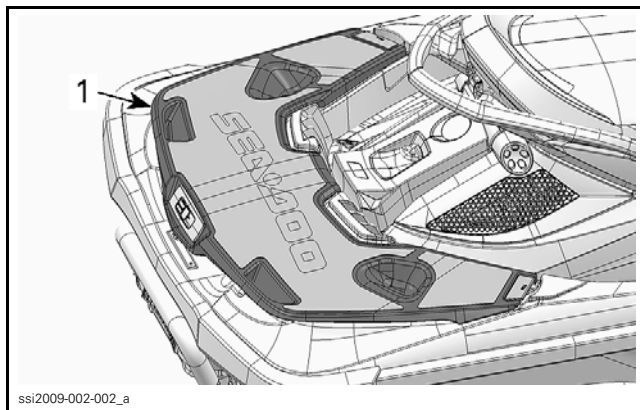

1. Boarding platform

Remove the RH (starboard) storage bin.

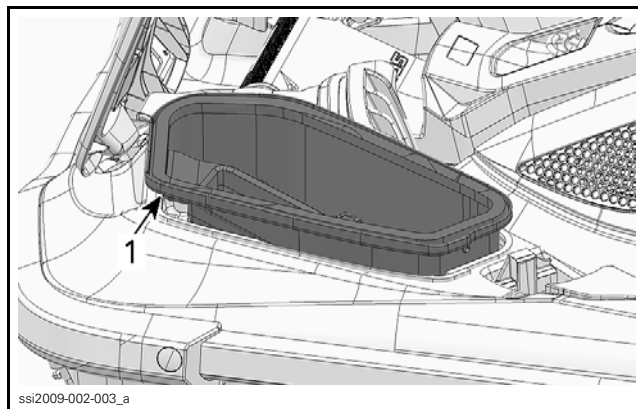

1. RH (starboard) storage bin

Disconnect the 6-pin diagnostic connector.

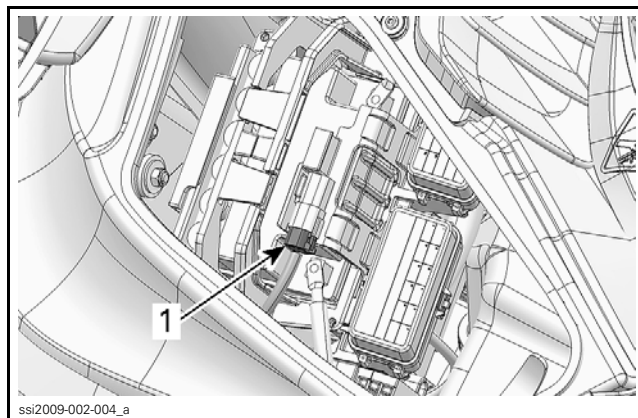

1. Diagnostic connector

Connect MPI-2 DIAGNOSTIC CABLE (P/N 710 000 851) to vehicle connector.

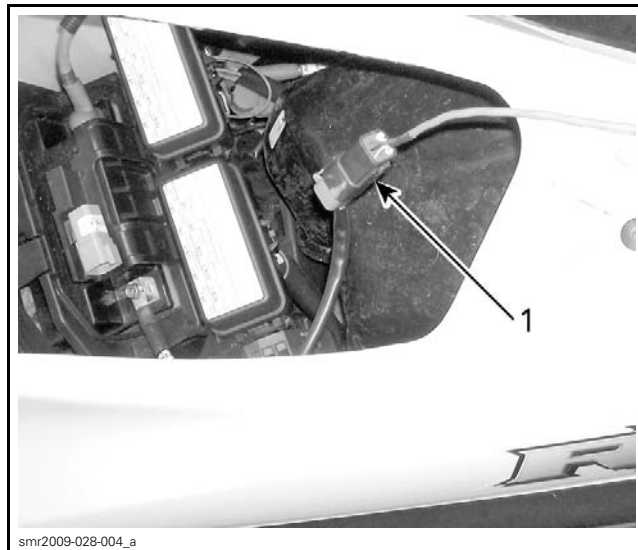

1. Diagnostic cable

Connect MPI-2 cable remaining connector to MPI-2 INTERFACE CARD (P/N 529 036 018).



NOTE: An optional MALE-FEMALE EXTENSION SERIAL CABLE (P/N DB9) available at electronic retail outlets can be used between diagnostic cable and MPI-2 interface. Do not exceed 7.6 m (25 ft).

Connect remaining MPI-2 interface card connector to the USB port of a PC (personal computer).



Use B.U.D.S. software as described further in *B.U.D.S. SOFTWARE*.

B.U.D.S. Software

IMPORTANT: Ensure all connections have been made **before starting B.U.D.S.** to allow proper operation.

Always use the latest B.U.D.S. version available on BOSSWeb.

Connect D.E.S.S. key to vehicle D.E.S.S. post.

Briefly press the start/stop button to power the ECM. **Engine must not crank.**

IMPORTANT

Approximately 3 minutes after pressing the start/stop button, the ECM will stop communicating with B.U.D.S. Therefore, all pending operations with B.U.D.S. will be temporarily interrupted until the start/stop button is briefly pressed.

To avoid the interruption, it is recommended to periodically briefly pressing the start/stop button before the ECM stops communicating. **Engine must not crank.**

Before writing data to the ECM, always quickly press the start/stop button to prevent ECM stops communicating during the write process.

If for some reason the writing operation fails, exit B.U.D.S. Restart B.U.D.S. and reenter all the previously lost information.

Start B.U.D.S. and logon.

Check MPI-2 protocol. It must be set to **Kw2000 (500K)**.

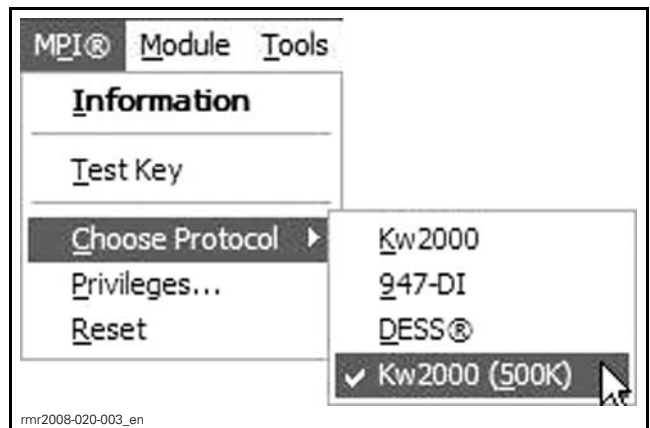

Ensure the status bar shows the Kw2000 (500K) and the number 4 to its right.

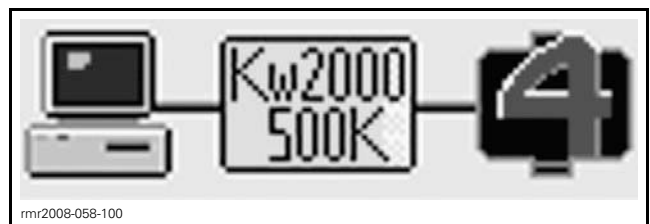

CONNECTION SUCCESSFUL

Number 4 means that 4 "ECUs" are connected:

- ECM
- Information center
- iBR
- iS

Read ECM by clicking the **Read Data** button.

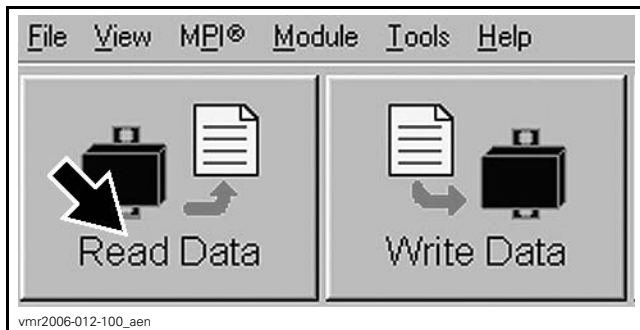

B.U.D.S. is now ready to use. Refer to *D.E.S.S. KEY PROGRAMMING* to complete procedure.

The MPI-2 includes 2 status lights to show the connection conditions: USB and CAN. **Both lights must be GREEN** so that MPI-2 works properly.

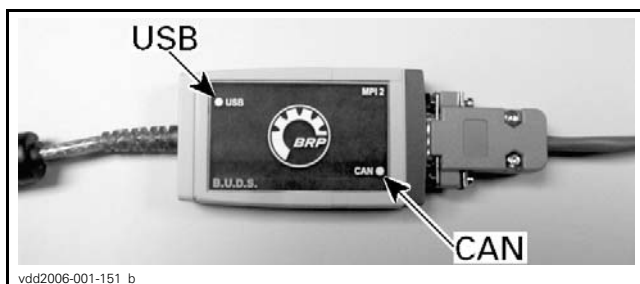

NOTE: If an "X" is shown in the status bar, it means that no "ECU" is communicating with the MPI.

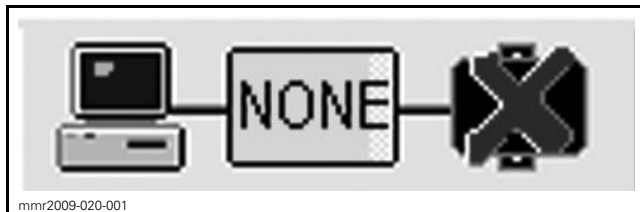

Check the following:

- MPI protocol in B.U.D.S.
- Connections between the PC computer and the vehicle.

If **No vehicle detected...** message box is displayed in B.U.D.S., refer to *COMMUNICATION TOOLS AND B.U.D.S. SOFTWARE* subsection in the appropriate *SHOP MANUAL*.

If **Some of the information normally displayed...** message box is displayed in B.U.D.S., refer to *COMMUNICATION TOOLS AND B.U.D.S. SOFTWARE* subsection in the appropriate *SHOP MANUAL*.

D.E.S.S. Key Programming

The D.E.S.S. keys are color-coded to differentiate them.

D.E.S.S. KEY TYPE	COLOR
Normal key	YELLOW or BLACK
Learning key	GREEN
Rental key	ORANGE

Install a D.E.S.S. key, to be added or erased, on watercraft D.E.S.S. post.



1. Key to be added or erased

Briefly press start/stop button to power the ECM. **Engine must not crank.**

NOTE: Press the start/stop button every three minutes otherwise the electrical system will shut off.

Click on **Keys** tab.

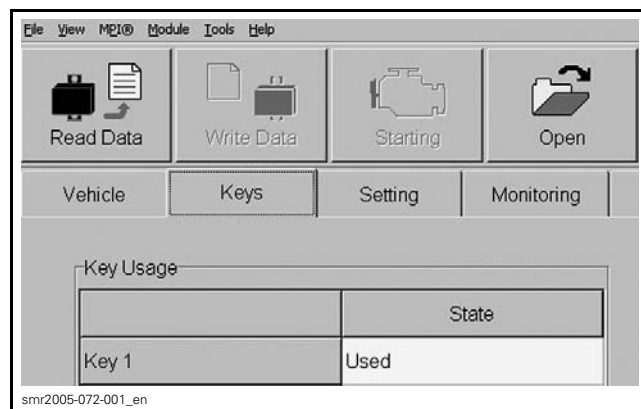

Adding a Key

Click on the desired **Add Key** button on bottom of screen according to the type of key you want to program.

⚠ WARNING

If programming a Learning or Rental key, make sure to use the proper key type (color) to avoid possible confusion. Failure to do so can result in severe injury or death for the operator.

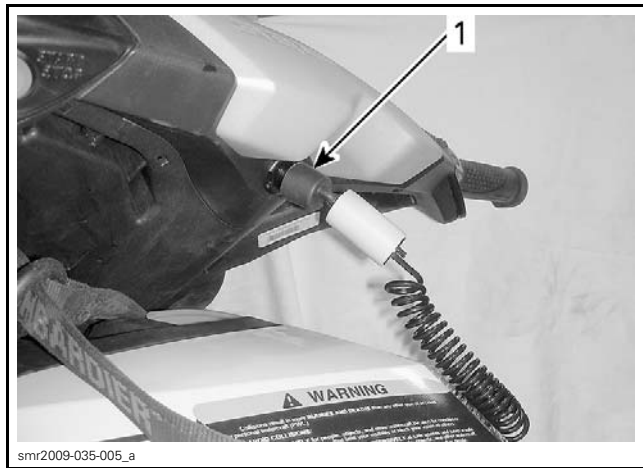

1. Key to be erased

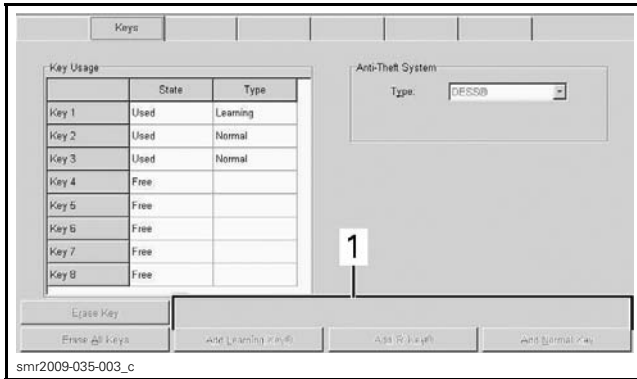

After approximately 10 seconds, the following window will pop up confirming the new key has been saved in the PC computer.



If programming is complete, write the changes to the ECM. Refer to *WRITING CHANGES TO ECM* in this subsection.

Adding another Key

Remove the key on D.E.S.S. post.

Install the next key to be programmed on D.E.S.S. post.

Click on the desired **Add Key** button.

If programming is complete, write the changes to the ECM. Refer to *WRITING CHANGES TO ECM* in this subsection.

Erasing one Key

Install the key to be erased to the watercraft D.E.S.S. post.

Click on **Erase Key** button at bottom of B.U.D.S. screen.

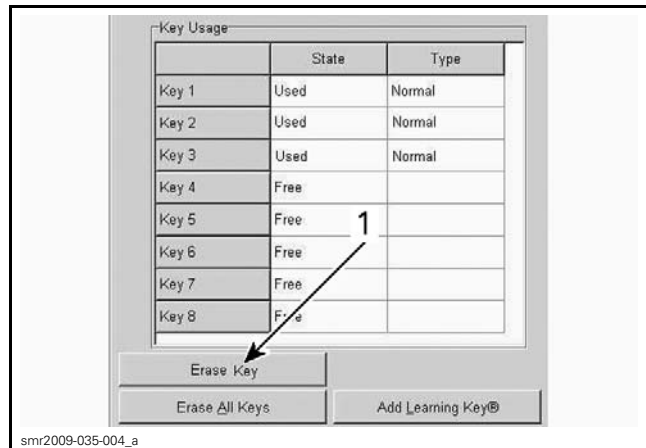

1. Click on this button

After approximately 10 seconds the following message will appear.



The key is now erased in the PC computer.

If programming is complete, write the changes to the ECM. Refer to *WRITING CHANGES TO ECM* in this subsection.

Writing Changes to ECM

Save the changes made in B.U.D.S. into the ECM as follows.

Briefly press the start/stop button to prevent ECM communication interruption during the write process. **Engine must not crank.**

Click the **Write Data** button.

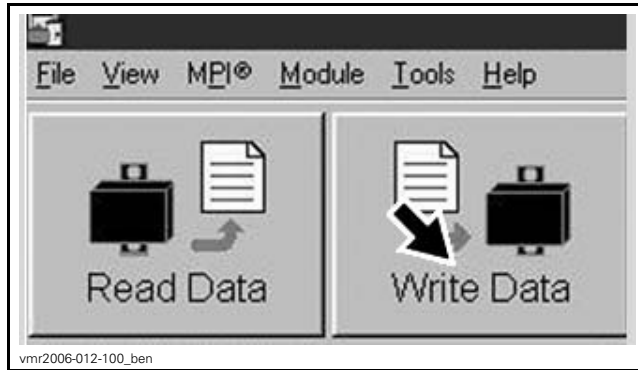

After the write operation, remove key from D.E.S.S. post.

Try the key(s) on the watercraft.

Setting Maximum Speed for Learning and Rental Keys

To change Learning or Rental Key settings, refer to the *OPERATOR'S GUIDE*.

Information Center Setup

Briefly press start/stop button to power the ECM. **Engine must not crank.**

NOTE: Press the start/stop button every three minutes or the electrical system will shut off.

Select the **Read Data** button.

Choose the **Setting** tab at the top of the page.

At the bottom LH side of the setting page, select the **Cluster** tab.

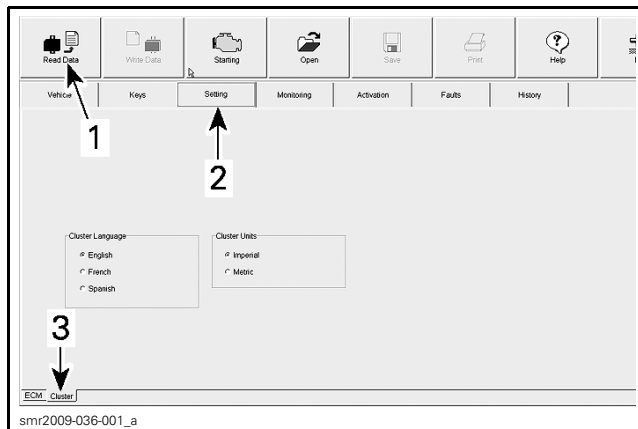

1. Read Data
2. Setting tab
3. Cluster tab

In the **Cluster Language** field, choose the desired unit of language, **English**, **French** or **Spanish**.

In the **Cluster Units** field, choose the desired unit of measurement, **Imperial** or **Metric**.

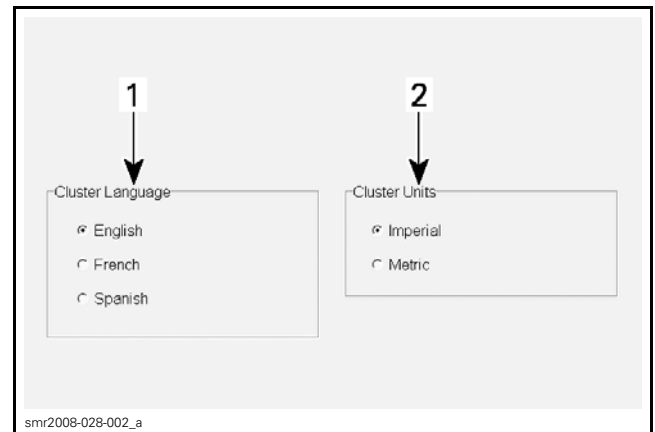

1. Cluster Language field
2. Cluster Units field

Unlock iS Suspension

The iS suspension is locked in B.U.D.S. and will not move until you click on the **UNLOCK iS** button.

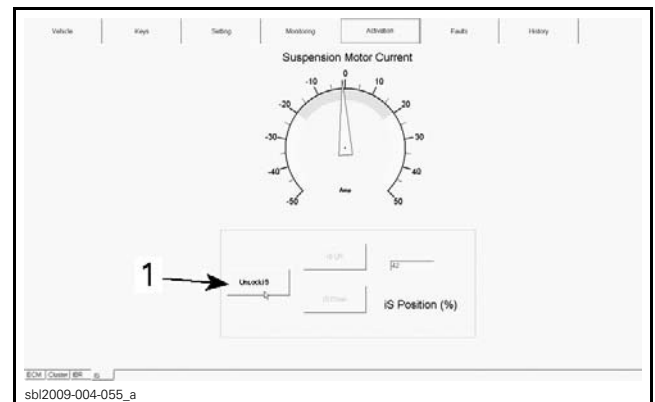

ACTIVATION AND IBR TABS

1. UNLOCK iS button

Ending a B.U.D.S. Session

Before ending the B.U.D.S. session, you need to clear the maintenance reminder indicators.

Choose the **Vehicle** tab at the top of the page.

At the bottom RH side of the vehicle page in the **Last Service** field, choose **Reset Service/"Maint"** button.

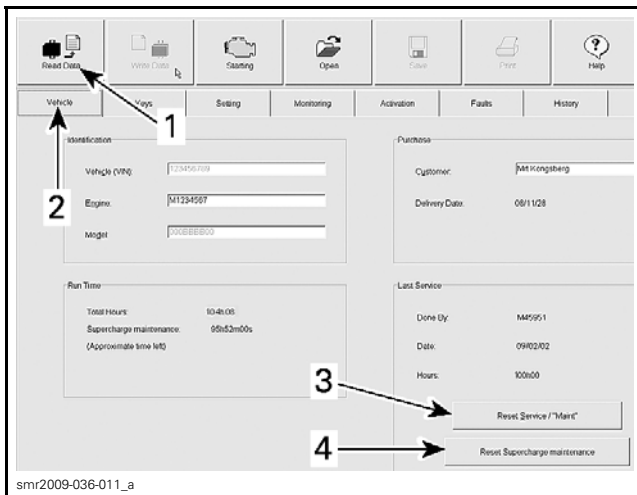

1. Read Data
2. Vehicle tab
3. Reset Service/"Maint" button
4. Reset Supercharge Maintenance button

When done, click on FAULT tab and check if there are active faults.

- If so, service watercraft then clear the faults in B.U.D.S.

NOTICE After a problem has been solved, ensure to clear fault(s) in ECM. This will properly reset appropriate counter(s).

Click on WRITE DATA button to transfer new settings and information.

Click on EXIT button (rightmost) to end session.

Disconnect all cables and hardware from vehicle.

Ensure to reinstall cap over the communication connector and all vehicle parts.

ADJUSTMENTS

Steering Alignment

Install two bungee cords to maintain steering during the procedure.

Position steering so that the edge of the steering column cover and edge of the gauge support are equal.

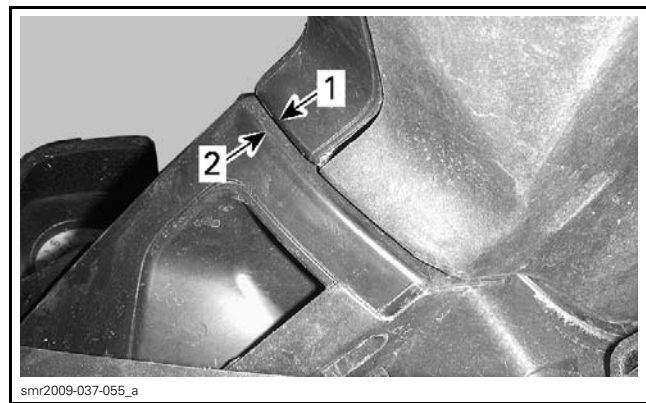

1. Steering column cover edge
2. Gauge support edge

Check jet pump nozzle position by placing a straight edge on nozzle outer end. Measure the distance on each side of the straight edge. It must be equalled.

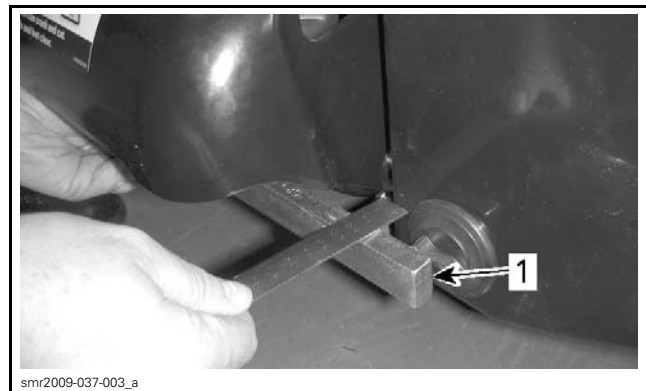

1. Straight edge places against nozzle

If necessary, steering alignment adjustment should be performed at steering column.

Open storage compartment cover and remove basket.

Loosen steering column clamp bolts securing the steering cable clamp at the bottom of steering column.

Turn adjusting nut as required.

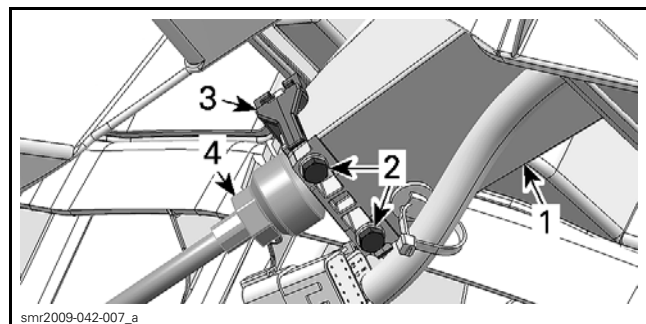

1. Steering column
2. Steering column clamp bolts
3. Steering column clamp
4. Steering cable adjusting nut

After adjustment, torque steering column clamp bolts to 6 N•m (53 lbf•in).

NOTICE Verify when the handlebar is turned completely to the left or right side, that there is no interference with jet pump or reverse parts.

FUEL SYSTEM PRESSURIZATION

Fuel System Pressurization Procedure

WARNING

A pressure test must be done before starting engine.

Pressurize fuel system, refer to the appropriate *SHOP MANUAL* for complete procedure.

FINAL INSPECTION

Vehicle Test Run

Ride the vehicle to ensure proper operation of the following systems and components.

1. Steering operation
2. Throttle lever operation (iTC™)
3. Brake lever operation (iBR™)
4. Reverse system operation (iBR)
5. Suspension system operation (iS)
6. VTS operation
7. Information center operation
 - 7.1 Speedometer
 - 7.2 Indicator lights
 - 7.3 Messages
 - 7.4 Features
 - 7.5 Etc.
8. Cruise and slow speed mode features
9. Hull leak check
10. Complete recall or factory-directed modification (if applicable)
11. Check for fault code with B.U.D.S.

Protective Films Removal

1. Slowly peel off protective films to remove it.
2. Remove bar code decal from handlebar.

Vehicle Cleaning

1. Clean watercraft thoroughly and polish.

NOTICE Clean apparent fiberglass and plastic parts with a clean cloth and soapy water or isopropyl alcohol. Never use strong detergent, degreasing agent, paint thinner, acetone, etc. Do not apply isopropyl alcohol directly on decals.

Delivery to Customer

1. Where possible, give a brief demo ride and explain watercraft operation.
2. Complete *PREDELIVERY CHECK LIST* following all instructions.
3. Explain, complete and return WARRANTY REGISTRATION CARD (legal requirement).
4. Customer must sign *PREDELIVERY CHECK LIST*.
5. Give to customer:
 - Operator's guide
 - Safety DVD
 - Copy of the *PREDELIVERY CHECK LIST*.
6. Explain to customer that it is necessary to press the start/stop button without installing safety lanyard to initially feed fuel system.
7. A tag is tied to handlebar. Leave it there until delivery and make sure customer reads it.
8. Explain to customer that with Sea-Doo watercraft powered by Rotax® engines, a break-in period of 10 hours is required before continuous operation at full throttle.
 - 8.1 To achieve a good break-in, vary engine speed every few minutes with brief wide open throttle accelerations of up to 15 seconds.

NOTICE Continued wide open throttle runs and prolonged cruising without speed variations should be avoided, this can cause engine damage during break-in period.

TECHNICAL DATA

VEHICLE		RXT IS 255	GTX LIMITED IS 255
		ENGINE	
Type		Rotax® 4-TEC™. Single Over Head Camshaft (SOHC)	
		255 hp	
Number of cylinder		3	
Number of valve		12 valves (4 per cylinder) with hydraulic lifters (no adjustment)	
Displacement		1494 cc (91.2 cu. in)	
Intake system	Type	Supercharged with external intercooler	
	Electronic Throttle body	60 mm	
Bore		100 mm (3.9 in)	
Stroke		63.4 mm (2-1/2 in)	
Compression ratio		8.4:1	
Cooling		Closed-loop system	
ELECTRICAL SYSTEM			
Ignition		IDI (inductive discharge ignition)	
Starter		Electric	
Battery		12 V, 30 A•h. Electrolyte type	
Spark plug	Make and type	NGK, DCPR8E	
	Gap	0.75 mm (.030 in)	
PROPULSION			
Propulsion system		Sea-Doo direct drive	
Jet pump	Type	Axial flow, single stage. Large hub with 10-vane stator	
	Material	Aluminum	
Impeller		Stainless steel	
Transmission	Type	Electronic: iBR, Direct drive (forward/neutral/reverse)	
VTS	Type	Electronic with Manual and Preset positioning	

VEHICLE		RXT IS 255	GTX LIMITED IS 255
		DIMENSIONS	
Length		353.5 cm (139.2 in)	
Width		122.4 cm (48.2 in)	
Height		127.7 cm (50.3 in)	
WEIGHT AND LOADING CAPACITY			
Weight (dry)		430 kg (948 lb)	
Rider capacity (refer to load limit)		1, 2 or 3	
Storage capacity		62 L (16,4 U.S. gal)	
Load limit (passengers + luggage)		226 kg (500 lb)	
FLUIDS			
Fuel	Type	Unleaded	
	Minimum octane	Inside North America: (87 (RON + MON)/2)	
		Outside North America: 92 RON	
	Recommended octane rating for optimum performance	Inside North America: (91 (RON + MON)/2)	
		Outside North America: 95 RON	
Tank capacity	70 L (18.6 U.S. gal)		
Engine oil	Type	XPS summer grade. Refer to <i>MAINTENANCE</i> section for more information.	
	Capacity	3 L (2.7 U.S. qt) oil change w/filter	
Cooling system	Coolant type	Ethylene-glycol 50%/50% antifreeze and demineralized water. Coolant containing corrosion inhibitors for internal combustion aluminum engines	
	Capacity	5.5 L (5 U.S. qt) total	

NOTE: BRP reserves the right to make changes in design and specifications and/or to make additions to, or improvements in its products without imposing any obligation upon itself to install them on its products previously manufactured.