

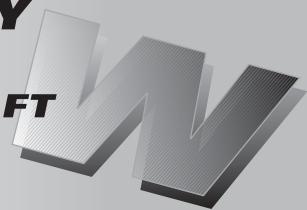

WARRANTY
CAMPAIGN

WATERCRAFT
WARRANTY
Bulletin



CAUTION: All involved customers must be notified, all involved units must be corrected as per instructions herein.

Campaign no.: 2008-0001

February 25, 2008

Subject: **RXT® Storage Cover Replacement**

No. **2008-1**

YEAR	MODEL	MODEL NUMBER	SERIAL NUMBER
2008	RXT RXT INT	178C / 178D	Refer to "Serial Number Listing of Involved Watercraft"

PROBLEM

The RXT models were assembled with wrong storage and mirror covers, white instead of silver.

SOLUTION

Replace wrong parts with correct parts.

PARTS REQUIRED

ITEM	DESCRIPTION	P/N	QTY
P1	Storage cover shell	269 501 685	1
P2	Mirror shell right	269 501 687	1
P3	Mirror shell left	269 501 688	1
P4	Rivets	293 150 001	4
P5	Rivet	293 150 029	1
P6	Washer	234 040 600	1
P7	Tie-rap	414 115 200	3
P8	"BRP" Logo	219 902 469	1
P9	Deflector decal	219 902 934	1
P10	LH deflector decal	219 902 936	1
P11	RH deflector decal	219 902 937	1
P12	M6 elastic nut	232 561 200	4

NOTE: DO NOT ORDER PARTS. Parts will be auto-shipped as per units ordered.
Parts will be shipped from February 26, 2008.

PROCEDURE

Removal

1. Remove BRP logo located on storage cover.

CAUTION: Be careful to not scratch paint on front fascia. A clean rag should be use between prying tool and front fascia.



2. Drill rivet located into BRP logo embossed location using a 5 MM (3/16) bit.

⚠ WARNING

Always wear **EYE PROTECTION AND APPROPRIATE GLOVES** when using power tools.

CAUTION: Be careful to not overheat plastic and damage front fascia.



sbg2008-001-210

3. Open storage compartment cover and remove cargo box.
4. Remove the circlip and washer from the shock rod.
5. Disconnect shock rod from storage cover.

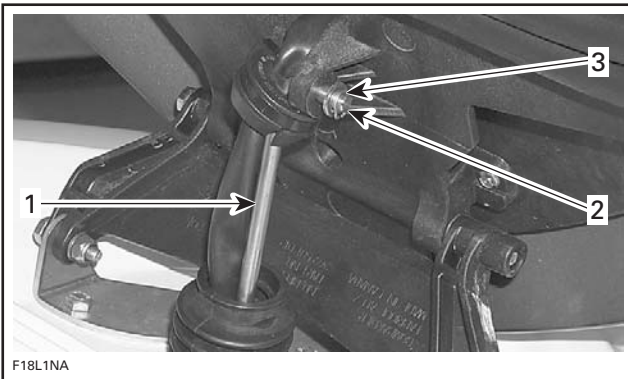

F18L1NA

1. Shock rod
2. Circlip
3. Washer

NOTE: Now shock rod is disconnected, storage cover will have to be kept open by an external way.

6. Remove plastic trim covers [1, 2] on screws (2 on each side).
7. Remove two short retaining bolts located in the lower back side of storage cover hinge [2]. Keep washers and bolts, discard nuts.

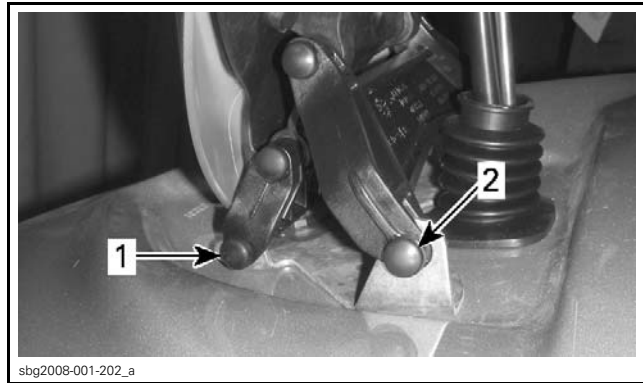

sbg2008-001-202_a

1. Plastic trim covers
2. Plastic trim covers with lower back side bolts

8. Now lower slightly cover to access and remove two short retaining bolts located in the lower front side and hold cover firmly.

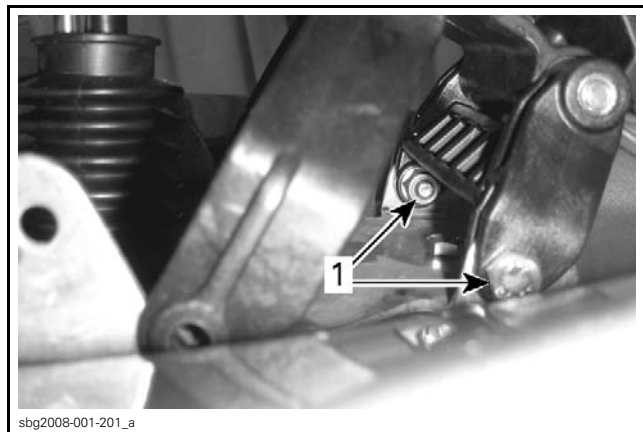

sbg2008-001-201_a

1. Lower front side bolts

Keep washers and bolts, discard nuts.

9. Disconnect multifunction cluster connector.

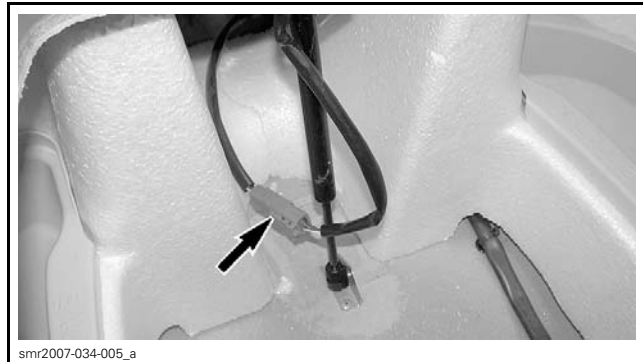

smr2007-034-005_a

10. Cut locking tie [1] retaining multifunction cluster wire loom into grommet [2].

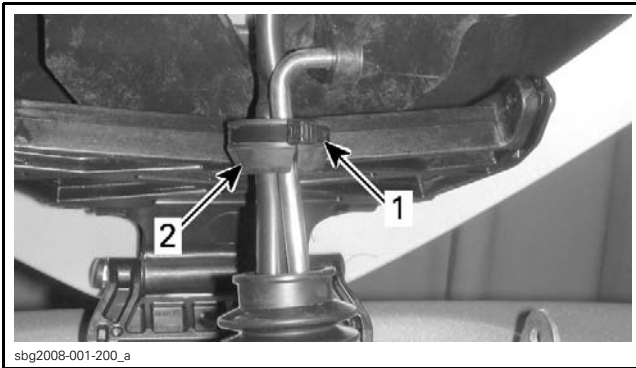

1. Locking tie
2. Grommet

11. Pull wire loom through grommet into cargo box emplacement.
12. Remove storage compartment cover.
13. Place storage cover on a clean workbench or table.
14. Remove seven inner shell short screws [3] (flanged screws).
15. Remove two long inner shell screws [4] (hexagonal screws).

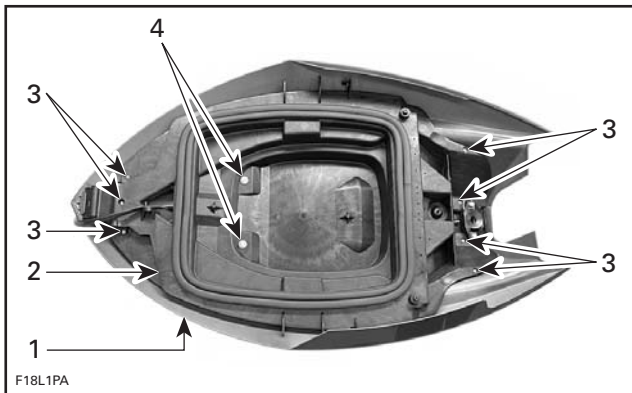

1. Storage cover
2. Inner shell
3. Inner shell short screws (x 7)
4. Inner shell long screws (x 2)

16. Use a rubber hammer to remove the inner shell from the cover. If the inner shell is too stiff, install a piece of 2 x 4 against the inner shell and hit it with the rubber hammer.

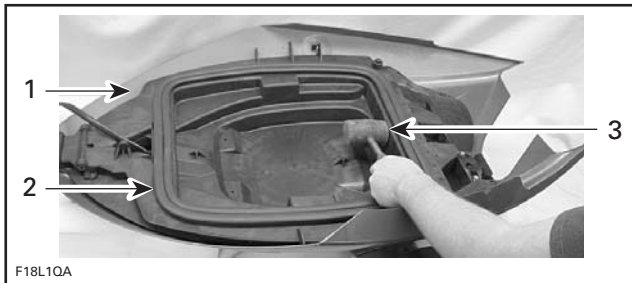

1. Storage cover
2. Inner shell
3. Rubber hammer

17. Remove connector harness from the inner shell by cutting tie raps.

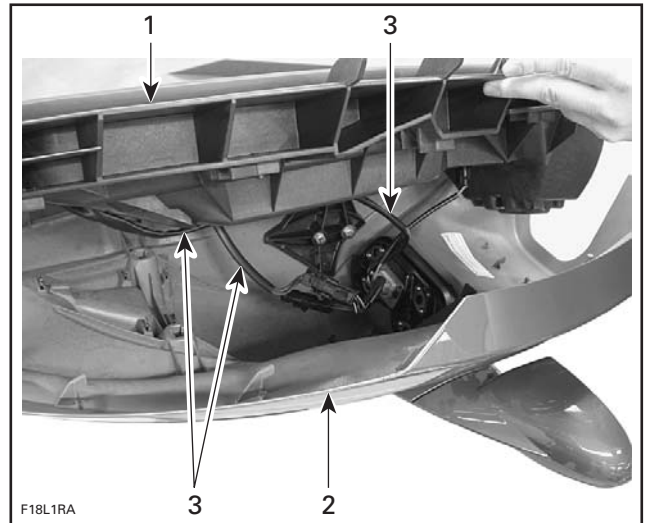

1. Inner shell
2. Storage cover
3. Connector harness

18. Remove inner shell.
19. Drill the 4 rivets [1] at front of upper storage cover.
20. Remove the 2 screws [2] at front of upper storage cover.

⚠ WARNING
Always wear EYE PROTECTION AND APPROPRIATE GLOVES when using power tools.

CAUTION: Be careful to not overheat plastic and damage front fascia

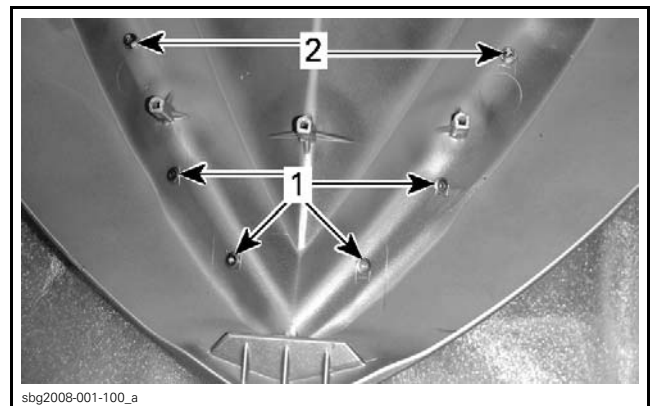

1. Rivets
2. Screws

21. Remove the 4 screws, 2 each side, of upper storage cover.

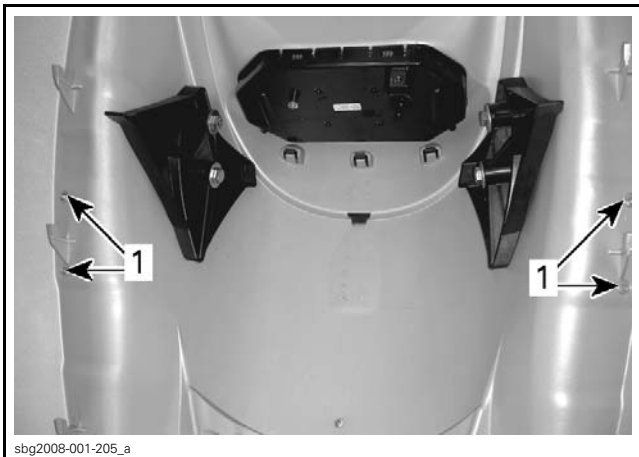

1. Screws

22. Carefully unlatch each plastic tab located under upper storage cover using flat screwdriver.

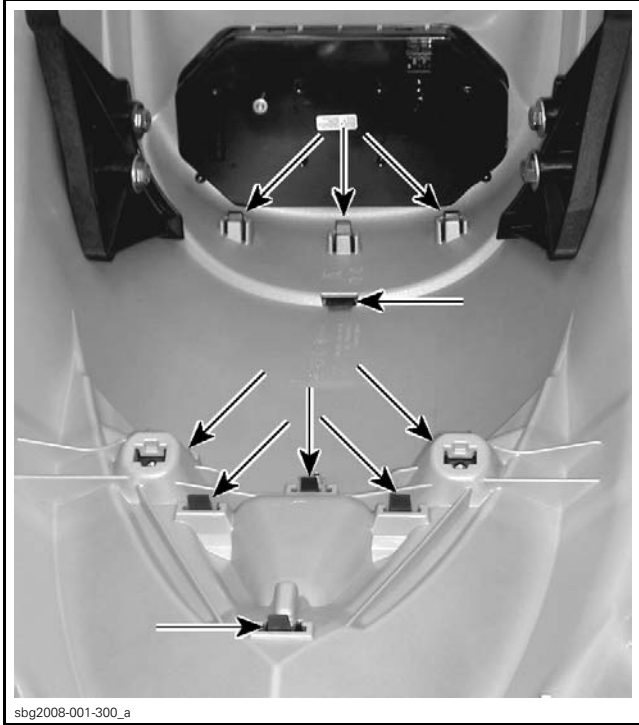

sbg2008-001-300_a

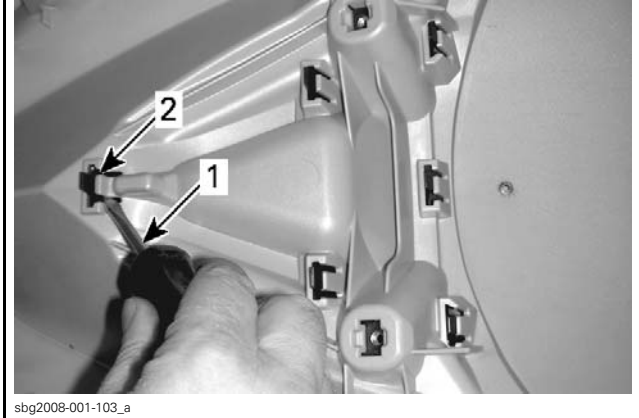

1. Flat screwdriver
2. Plastic tab

CAUTION: Plastic tabs are easily breakable.

- 23. Carefully remove front fascia with deflectors from upper storage cover.
- 24. Remove remains of rivets from front fascia.
- 25. Remove the 4 bolts securing the mirror shells.

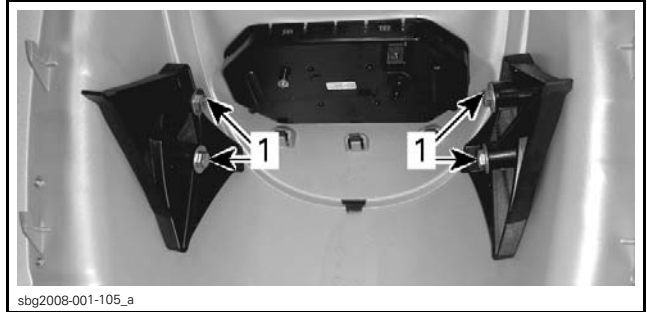

1. Mirror bolts

CAUTION: Long bolt on each side secures mirrors into shells. be careful that mirrors won't fall when removing mirror assemblies from front storage cover.

- 26. Remove mirror assemblies from front storage cover.
- 27. Pry out mirrors from mirror shells.

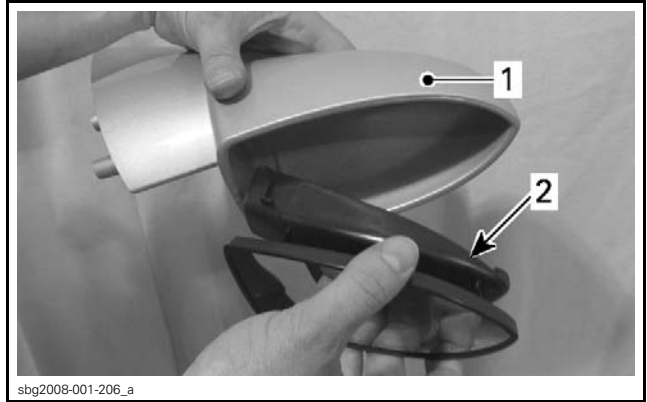

1. Mirror shell
2. Mirror

- 28. Keep mirrors, discard mirror shells.
- 29. Take a small wooden stick (coffee stirrer type) and chamfer its end; refer to photo.

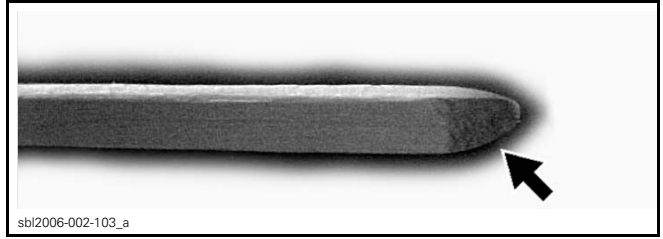

sbl2006-002-103_a

- Slide chamfered end between bezel and cluster, in line with each side locking tab, pushing out smoothly while lifting out bezel; repeat procedure with lower locking tab and then, gently lift bezel upward, out of its upper locking tabs.

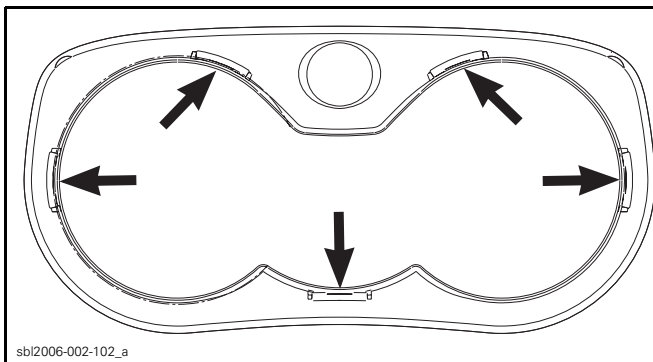
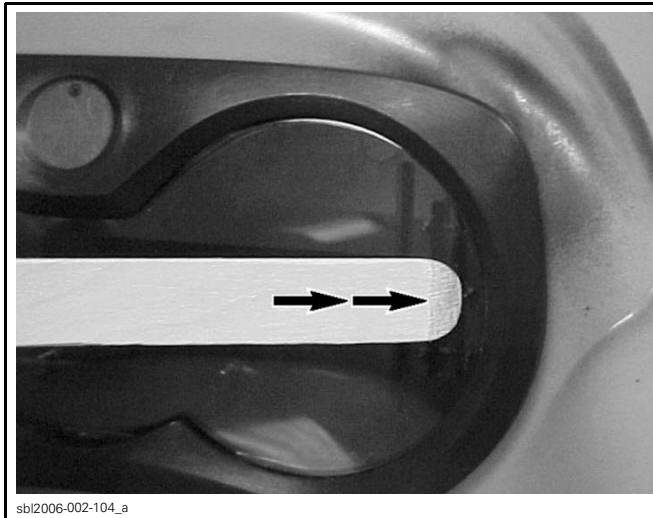

- Remove and keep both screws [1] retaining instrument cluster.
- Remove cluster from upper storage cover.
- Remove rubber shims [2] which are folded on body for a tight fit. Keep them for reuse when reinstalling cluster on new upper storage cover.

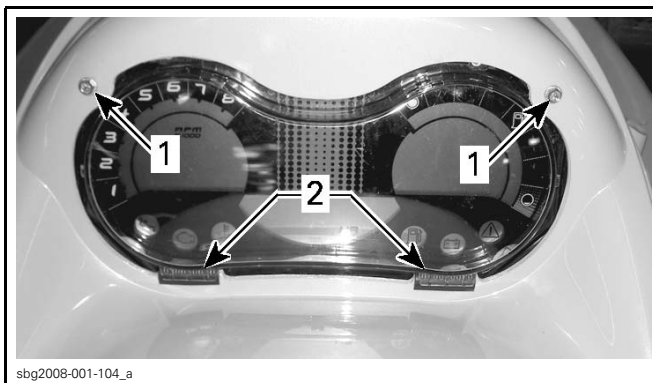

- Screws
- Rubber shims

Installation

- Place mirror into new right mirror shell [P2].

NOTE: Mirror should be pressed against plastic tabs into mirror shell.

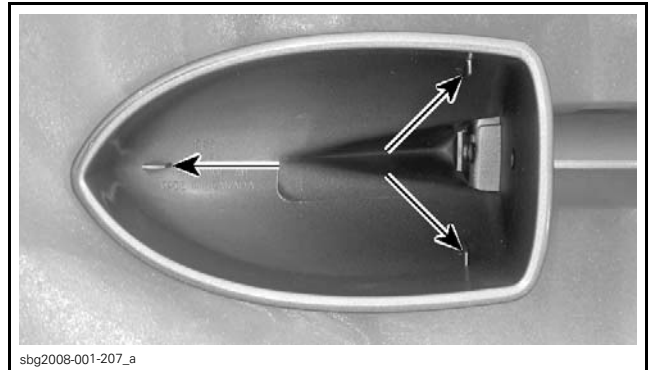

NOTE: Install left and right mirrors so that inscription "OBJECTS IN MIRROR ARE CLOSER THAN THEY APPEAR" is in upright position.

- Install mirror assembly onto new silver upper storage cover [P1] as they were on factory installed cover.

CAUTION: Long bolt on each side secures mirrors into shells. be careful that mirrors won't fall when re-installing mirror assemblies on the new front storage cover.

NOTE: To ensure a correct installation, screw rear bolt which hold mirror before.

Torque to 5 N•m (44 lbf•in).

Repeat operations for left mirror assembly [P3].

- Reinstall cluster rubber shims on new upper storage cover.
- Install instrument cluster onto new upper storage cover and secure back in place using same screws.

Torque screws to a **MAXIMUM** of 1.5 N•m (13 lbf•in).

- Reinstall instrument cluster bezel simply by pushing it in so it snaps back in place.
- Install fascia assembly and front deflector on new storage cover shell.

NOTE: Make sure each deflector or fascia tab is correctly latched onto upper storage cover.

CAUTION: Plastic tabs are easily breakable.

- Reinstall the 6 screws, 2 each side and 2 at front of upper storage cover.

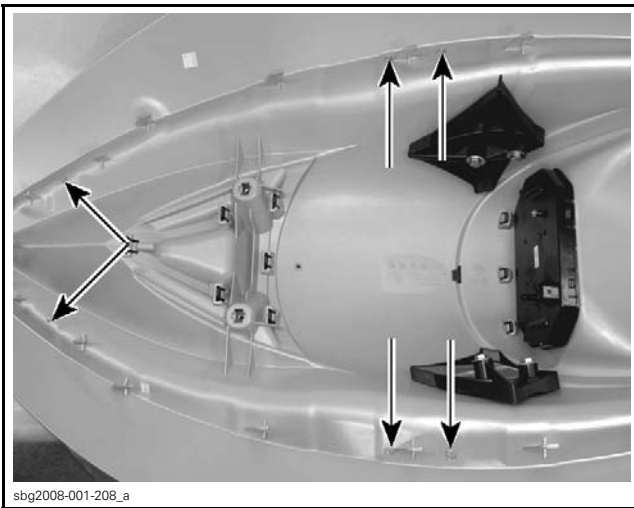

Torque screws to a **MAXIMUM** of 1 N•m (9 lbf•in).

8. Install 4 rivets [P4] at front of upper storage cover.

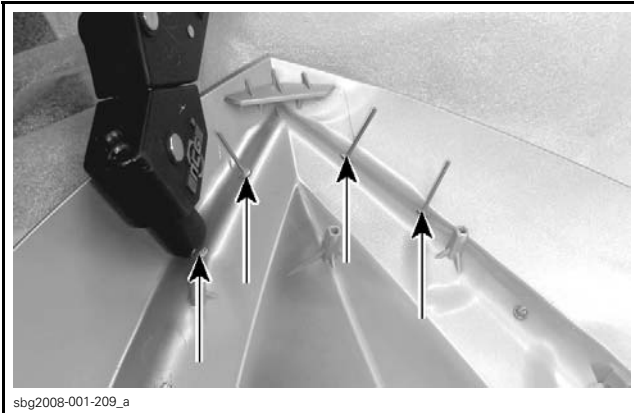

9. Install rivet [P5] into outside center of upper storage cover, located underneath BRP logo location. Put washer [P6] inside.

10. Align inner shell with storage cover and make sure that the lateral locking hooks in the inner shell get engaged in the storage cover locking bracket. If the two lateral locking hooks get properly aligned and engaged, the storage cover back locking hook will be engaged properly in the inner shell back locking bracket.

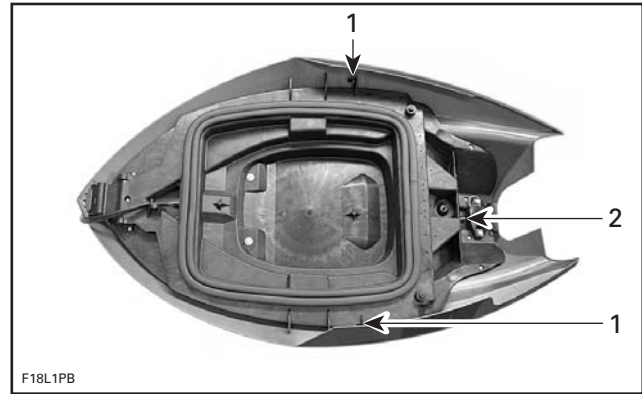

1. Inner shell lateral locking hook
2. Inner shell back locking bracket

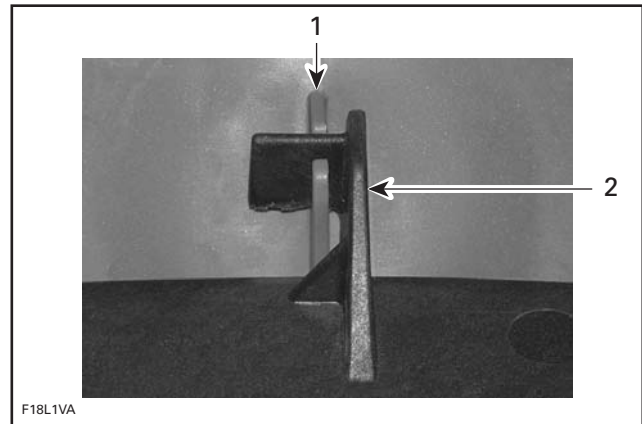

1. Storage cover lateral locking bracket
2. Inner shell lateral locking hook

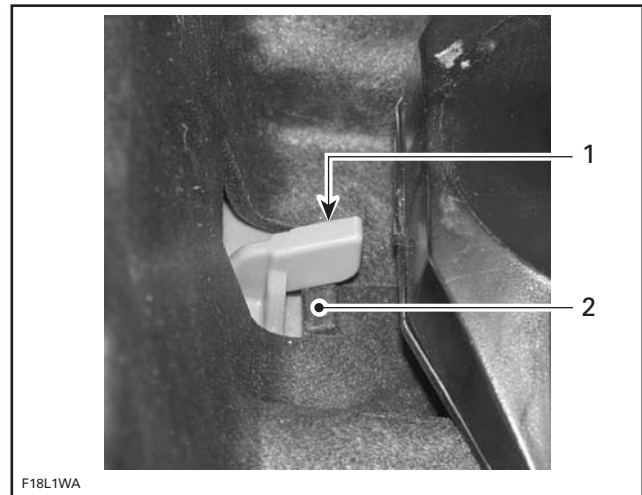

1. Storage cover back locking hook
2. Inner shell back locking bracket

11. Secure the inner shell in the storage cover by using a rubber hammer.

12. Fasten the seven inner shell short screws.

Torque screws to a **MAXIMUM** of 1 N•m (9 lbf•in).

13. Fasten the two inner shell long screws.

Torque screws to a **MAXIMUM** of 4 N•m (35 lbf•in).

14. Reinstall new storage cover onto vehicle in half open position.

15. Reinstall two short retaining screws located in the front lower side of storage cover hinge.

16. Secure with new M6 nuts [P12] and previously removed washers.

Torque to 5 N•m (44 lbf•in).

17. Position storage cover in wide open position.

18. Reinstall two short retaining screws located in the rear lower side of storage cover hinge.

19. Secure with new M6 nuts [P12] and previously removed washers.

Torque to 5 N•m (44 lbf•in).

20. Reinstall plastic trim covers [1, 2] on screws (2 on each side).

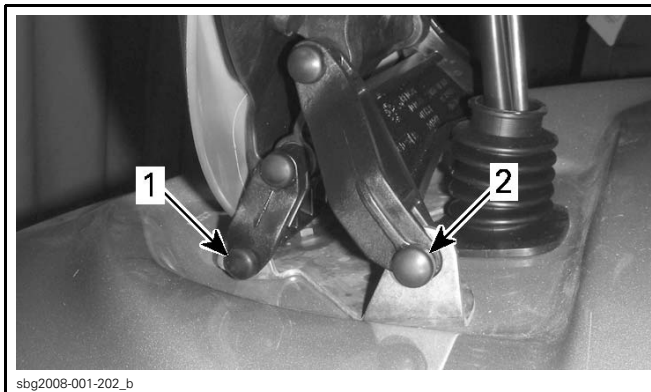

1. Lower front side bolt (with plastic trim cover)
2. Lower rear side bolt (with plastic trim cover)

21. Route wire loom through grommet from cargo box emplacement.

22. Install new locking tie retaining multifunction cluster wire loom into grommet.

23. Install locking ties securing wire loom to storage cover.

24. Reconnect multifunction connector.

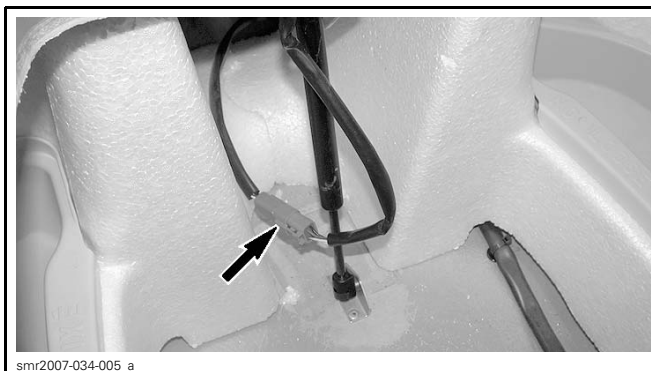

25. Re-install shock rod to storage cover.

26. Re-install washer and circlip securing shock rod.

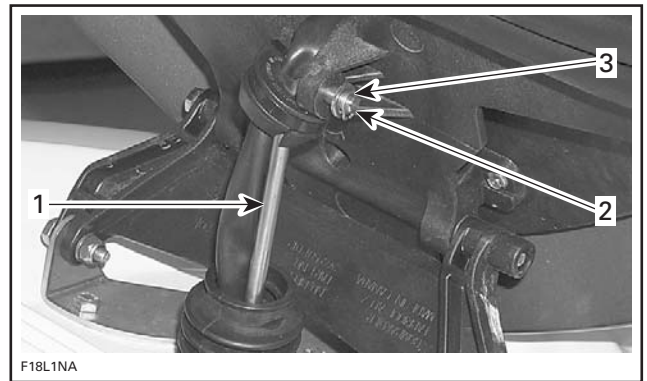

1. Shock rod
2. Circlip
3. Washer

27. Reinstall cargo box into storage compartment.

Decals Installation

Install decals [P8 - P11] on storage cover as described on next steps.

1. Clean decal installation surfaces with isopropyl alcohol and dry thoroughly.

2. Install new BRP logo [P8] located on fascia.

NOTE: Install BRP logo in upright position.

3. Using a pencil and the decal as a template, mark the area where decal will be located.

– Seadoo decals [P10, P11] go each side of storage cover, about 6 mm (1/4 ") from edges as shown.

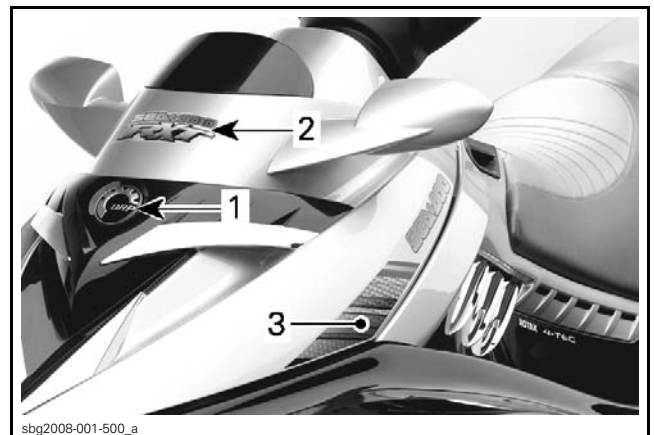

1. RXT decal [P9]
2. BRP logo [P8]
3. Seadoo decals (LH shown)

– RXT decal [P9] must be centered from left to right, between fascia and deflector, at 63 mm (2.5") from fascia.



sbg2008-001-501_a

1. Center line
2. 63 mm (2.5") from fascia

4. Remove back protective film from decal and carefully align decal with marks.
5. When well aligned squeegee decal beginning at center and working outward using firm, short, overlapping strokes.

CAUTION: Do not use soapy water to locate decal on plastic parts.

WARRANTY

Submit a warranty claim using the following information.

CAMPAIGN NUMBER	2008-0001
Claim Type	Campaign Claim
Flat rate time	1 hour
Return defective parts	Mirror shells left, right
Ordering new parts	No

IMPORTANT: Dealers must return parts to support their claims.

Canadian Dealers/Distributors,

Please return the above-requested part to:

BRP,
 Warranty Parts Inspection Center,
 565 de la Montagne,
 Valcourt (Québec)
 JOE 2L0

USA Dealers/Distributors,

Please return the above-requested part to:

BRP,
 c/o Warranty Department,
 7575 Bombardier Court,
 Wausau, WI
 54401

International,

Parts must be returned to the distributor or BRP

Regional Office. Contact them for complete address and shipping information.

For claiming procedure, refer to the *Dealer/Distributor Warranty Guide*.

SERIAL NUMBER LISTING OF INVOLVED VEHICLES

Model: 178C

From 048009 to 048025
From 048027 to 048041
From 048043 to 048051
From 048053 to 048067
From 048069 to 048070
048072
From 048074 to 048082
048084
From 048087 to 048089
048092
From 048095 to 048096
From 048099 to 048101
From 048105 to 048124
From 048127 to 048132
From 048134 to 048136
From 048138 to 048158
From 048160 to 048162

Model: 178D

048166
048170
048183
From 048185 to 048186
048191
From 048193 to 048194
048203
048205
048208