

Date : **June 27 2008** Subject : **Service Tools** No 2008-8

| Year | Model |
|------|-------|
| All | All |

BRP is proud to introduce its latest Service Tools Bulletin. These special tools were designed to help you efficiently service BRP vehicles. Please always make sure to use special tools along with the appropriate Shop Manual(s) and respect all safety measures.

Mandatory Tools: These tools are absolutely needed to perform certain service procedures. They will be automatically shipped to dealerships. They do not need to be ordered separately.

Recommended Tools: These tools will facilitate the Technicians work. They will not be automatically shipped to dealerships. They need to be ordered separately.



Table of contents

Tools by System:

| | | |
|---------------------------------|---|----|
| Engine | P | 2 |
| Fuel | P | 10 |
| Cooling | P | 11 |
| Electrical | P | 12 |
| Lubrication | P | 15 |
| Propulsion / Transmission | P | 15 |
| Steering | P | 18 |
| Suspension | P | 18 |
| Various | P | 19 |

| | | |
|---|---|----|
| Index of tools by Part Number: | P | 21 |
|---|---|----|

Engine

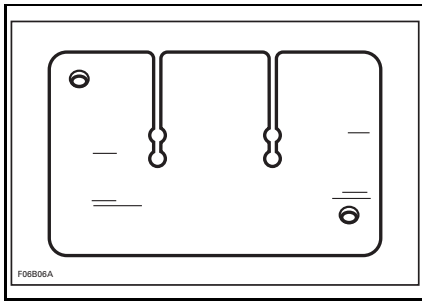

Protective Rubber Pad
P/N 290 877 032 Recommended
 947 DI engines

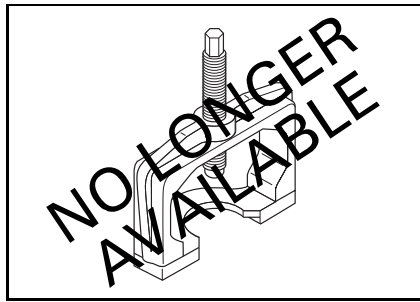

Gear / Bearing Puller
P/N 290 877 665 Recommended
 787 engines
 No longer sold; a standard puller can be used.

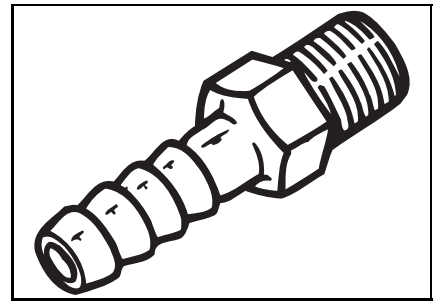

Male Fitting
P/N 295 000 086 Recommended
 4-TEC 1503
 To test jet pump tightness on 2-stroke.

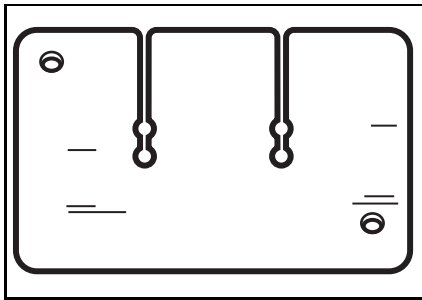

Protective Carpet
P/N 295 000 101 Recommended
 717 / 787 RFI engines
 So piston bearing does not fall in base during replacement.

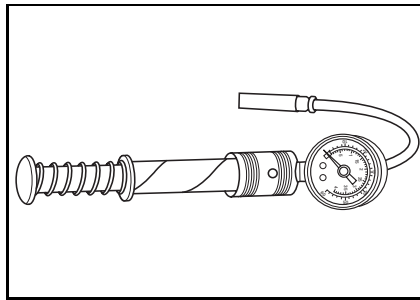

Leakage Tool MIKUNI BN Pump
P/N 295 000 114 Recommended
 All carbureted engines
 To leak test carburetor pop-off pressure.

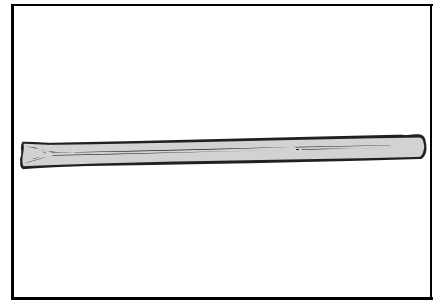

FLYWHEEL HOLDER
P/N 295 000 125 **Mandatory**
 587/657/717 engines
 Use with 420 876 080.

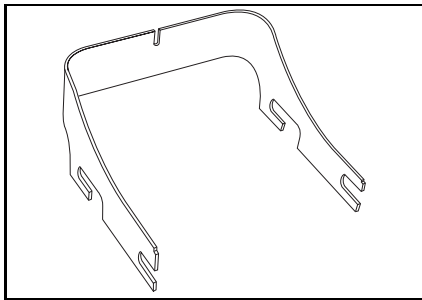

Timing Gauge 717
P/N 295 000 130 Recommended
 717 engines



Timing Gauge
P/N 295 000 135 Recommended
 787, 787 RFI, 947, 947 DI engines

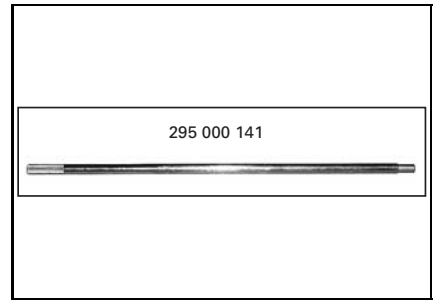

Shaft Alignment Tool
P/N 295 000 141 **Mandatory**
 All models

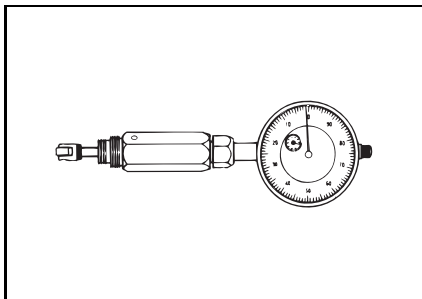

TDC Dial Indicator
P/N 295 000 143 Recommended
 2-stroke engines except DI



Flywheel Puller
P/N 295 000 156 **Mandatory**
 787 RFI

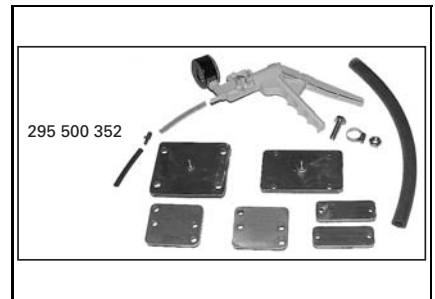

Engine Leak Test Kit
P/N 295 500 352 **Mandatory**
 All 2-stroke engines
 Kit includes vacuum pump 529 021 800.

Engine

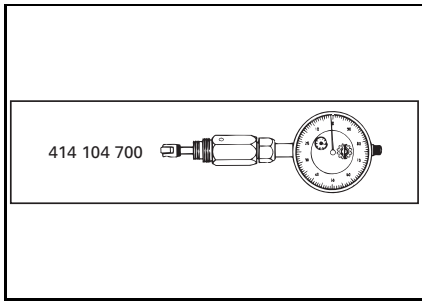

TDC dial indicator 25 mm
P/N 414 104 700 Recommended
 For ignition timing static measurement

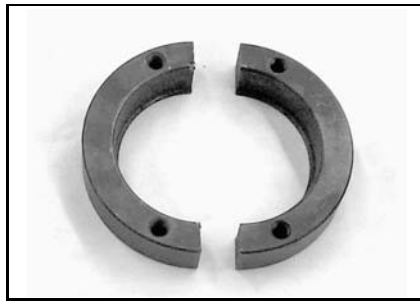

HALF RING PULLER MAG
P/N 420 276 025 Recommended
 717 engine
 To remove crankshaft bearings.

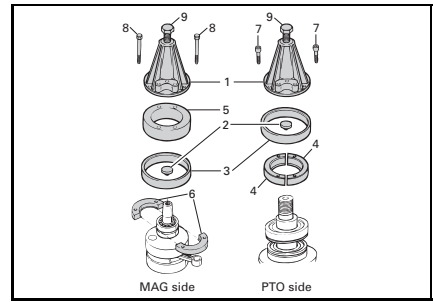

Screw M8x40 (item #7)
P/N 420 840 681 Recommended
 All 2-stroke engines

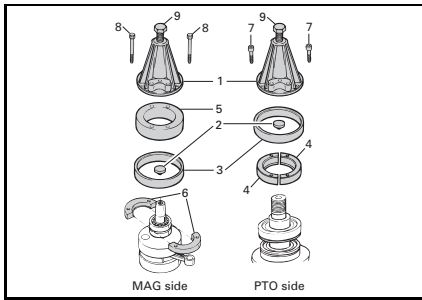

Screw M8x70 (item #8)
P/N 420 841 201 Recommended
 All 2-stroke engines
 To be used with P/N 420 877 635.

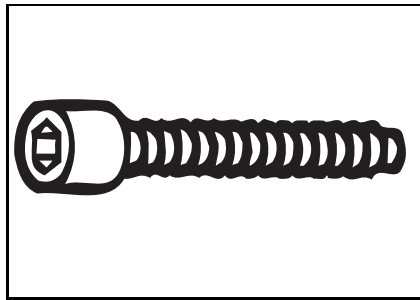

Screw M8x35 (qty 3)
P/N 420 841 591 Recommended
 717 engines
 To be used with 529 035 533.

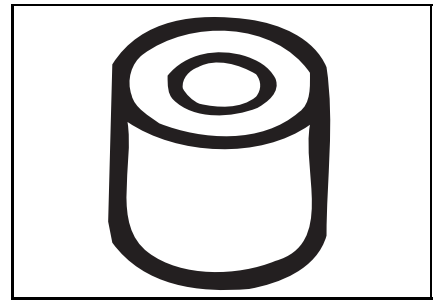

Sleeve
P/N 420 847 220 Recommended
 717 engines
 Use with 420 876 080.



Half ring puller
P/N 420 876 330 Recommended
 947 & 947 DI engines
 To remove 52 mm O.D. bearings from the crankshaft.



Rotary Valve Shaft Puller
P/N 420 876 488 Recommended
 717, 787 & 787 RFI engines
 Kit includes 420 240 860 / 232 400 414.

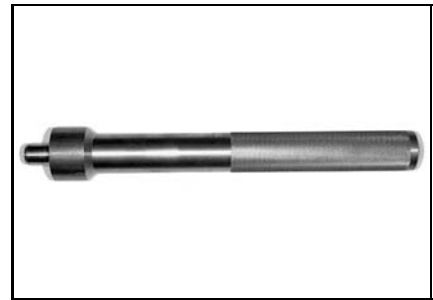

Rotary Valve Bearing Pusher
P/N 420 876 501 Recommended
 717, 787 & 787 RFI engines

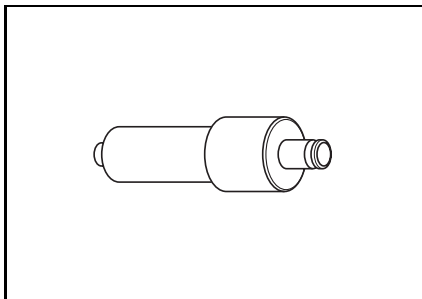

Starter Drive Seal Pusher
P/N 420 876 502 Recommended
 947 & 947 DI engines
 For starter drive



Crankshaft Protector
P/N 420 876 552 Recommended
 All 2 stroke, except 247 (PTO)
 Use with 420877635



Crankshaft Protector
P/N 420 876 557 Recommended
 717 / 787 RFI / 800R / 800 HO

Engine



Crankshaft Distance Ring (MAG)
P/N 420 876 569 Recommended
 All 2-stroke engines

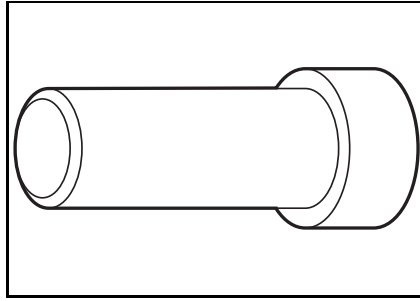

Rotary Valve Shaft Installer
P/N 420 876 605 Recommended
 717 engines & older than 1990

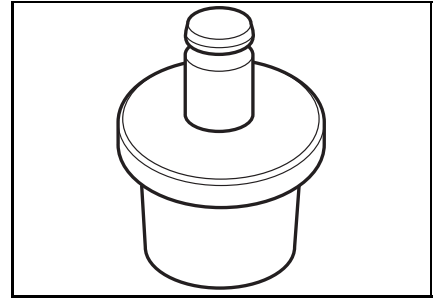

Rotary Valve Shaft Installer
P/N 420 876 609 Recommended
 787 & 787 RFI engines
 Use with 420 877 650

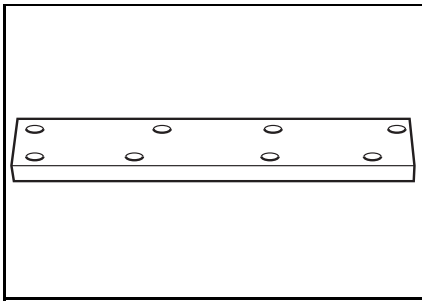

Cylinder Alignment Tool
P/N 420 876 904 Recommended
 717 engines



PISTON RING COMPRESSOR 88mm
P/N 420 876 965 Recommended
 947 & 947 DI engines



PISTON RING COMPRESSOR 82mm
P/N 420 876 979 Recommended
 717, 787 & 787 RFI engines



Crankshaft Protector
P/N 420 877 414 **Mandatory**
 947 DI engines

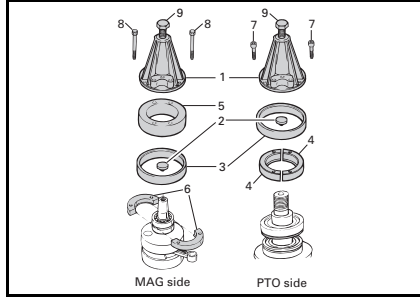

Puller et bolt (item 1 & 9)
P/N 420 877 635 Recommended
 All 2-stroke engines

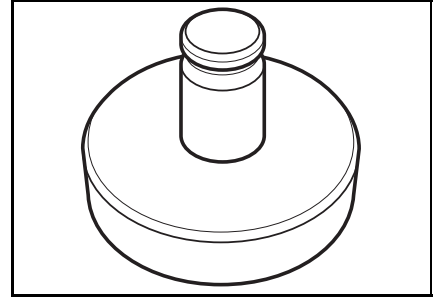

Oil Seal Pusher
P/N 420 877 740 Recommended
 787 RFI engines
 Used with 420 877 650.

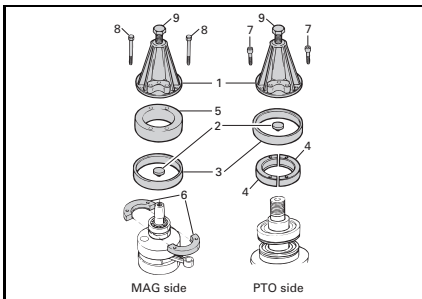

Replacement Puller Bolt (item #9)
P/N 420 940 755 Recommended
 All 2-stroke engines
 To use with puller P/N 420 877 635.



Flywheel puller
P/N 420 976 235 **Mandatory**
 247, 787, 787 RFI, 947 & 947 DI engines
 Replacement bolt P/N 529 035 549.



HALF RING PULLER
P/N 420 977 475 Recommended
 717 / 787 RFI engines

Engine

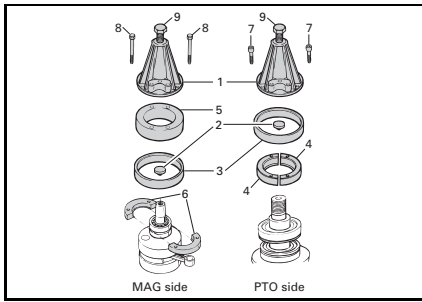

HOLDER RING (item #3)
P/N 420 977 480 Recommended
 947DI engines

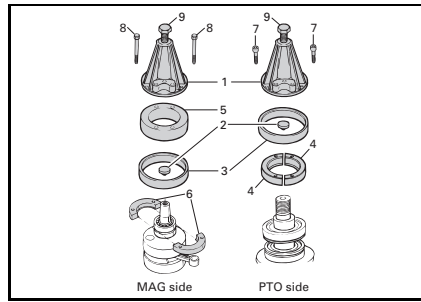

RING PULLER (item #3)
P/N 420 977 490 Recommended
 717/787RFI engines



Vacuum pressure pump
P/N 529 021 800 Recommended
 All models

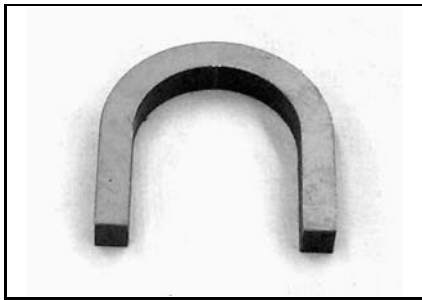

Distance Gauge 14 mm
P/N 529 034 800 Recommended
 717 engines

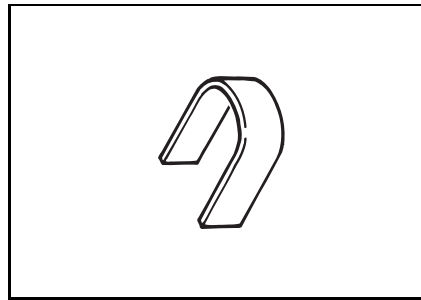

Distance Gauge 15.4mm
P/N 529 034 900 Recommended
 787 RFI engines

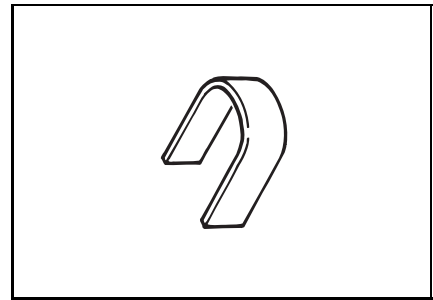

Distance Gauge 7.5mm (PTO)
P/N 529 035 000 Recommended
 947 DI Engine

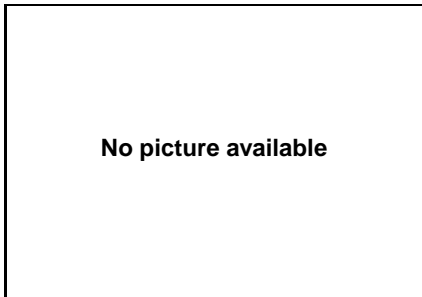

Distance gauge 11.5mm (MAG)
P/N 529 035 100 Recommended
 947 DI engines

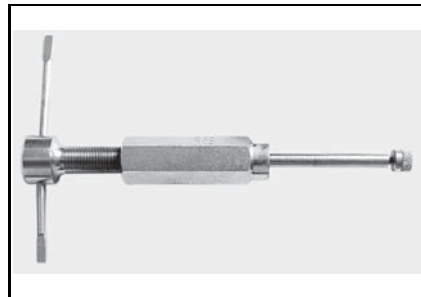

Piston pin puller
P/N 529 035 503 **Mandatory**
 All 2-stroke engines

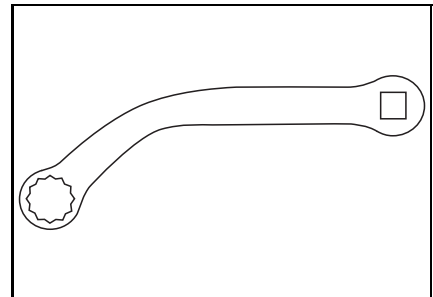

Exhaust Wrench 15mm
P/N 529 035 505 **Mandatory**
 947 DI engines



Replacement Protector Sleeve
P/N 529 035 513 Recommended
 To be used with P/N 529 035 503.



Flywheel Tool
P/N 529 035 533 **Mandatory**
 All 947 and 947 DI
 Use in conjunction with 529 035 547 puller
 and 295 000 125 holder.



Sleeve kit 18 mm
P/N 529 035 541 Recommended
 Ski-Doo 277, Sea-Doo 587
 To install cageless bearings. Used with
 529035503

Engine

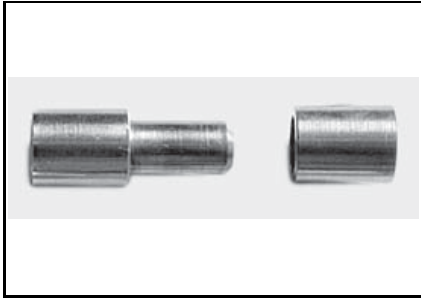

Sleeve kit 20 mm
P/N 529 035 542 **Mandatory**
 717, 787 RFI, 600, 800HO
 Used with 529035503

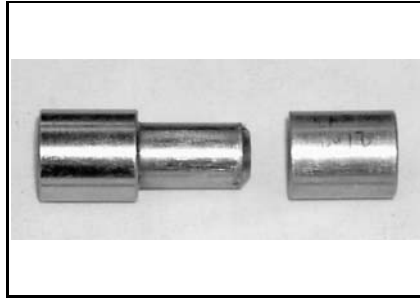

SLEEVE Kit 21mm
P/N 529 035 543 **Mandatory**
 947, 947 DI, 800 R Engines
 To install cageless bearings. Used with
 529035503

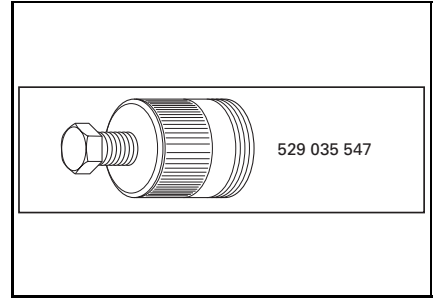

Flywheel Puller
P/N 529 035 547 **Mandatory**
 Replacement bolt 529035549. Use
 20876081/295000125/420841591/2908472
 20



Bolt M16 x 1,5 x 65mm
P/N 529 035 549 **Recommended**
 DS 450
 Goes with 529 035 547 & 420 976 235.



Spring installer remover
P/N 529 035 559 **Recommended**
 Replaced by 529035983 or 529035989



Circlip Insertion Tool 18 mm
P/N 529 035 561 **Recommended**
 Sea-Doo 587, Ski-Doo 277 engines

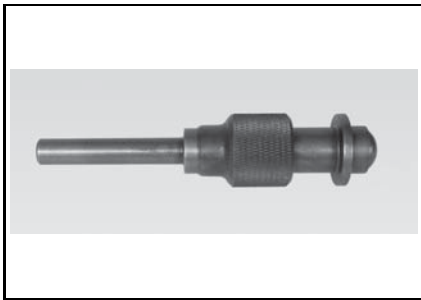

Circlip insertion Tool 20 mm
P/N 529 035 562 **Recommended**
 593, 670, 693, 717, 787 & 787 RFI engine
 Sleeve without groove P/N 529 035 567
 also available.

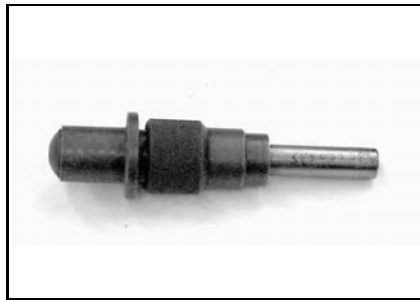

Circlip Insertion Tool 21 mm
P/N 529 035 563 **Recommended**
 947 & 947 DI engines
 Sleeve without groove, P/N 529 035 569
 also available.



20 mm Sleeve
P/N 529 035 567 **Recommended**
 Use with 529 035 562.



21 mm Sleeve
P/N 529 035 569 **Recommended**
 Use with P/N 529 035 563.



Insert Alignment Tool
P/N 529 035 590 **Mandatory**
 XP & XP DI models

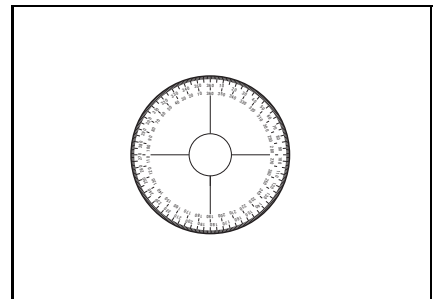

Degree Wheel
P/N 529 035 607 **Mandatory**
 All rotary valve engines

Engine



Engine leak down test kit
P/N 529 035 661 Recommended
 All 4-stroke engines
 To perform a leak down test on engine.



Valve stem seal installer
P/N 529 035 687 Recommended
 610 engine



Intake Plug
P/N 529 035 708 **Mandatory**
 947DI engines



COMPRESSOR RING
P/N 529 035 713 **Mandatory**
 947DI engines

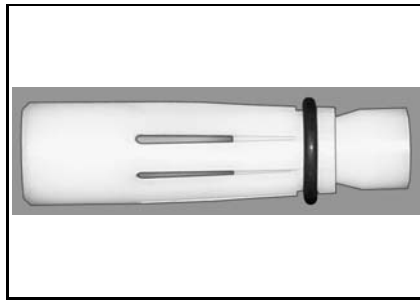

Carbon Dam Guide
P/N 529 035 715 **Mandatory**
 947 DI engines

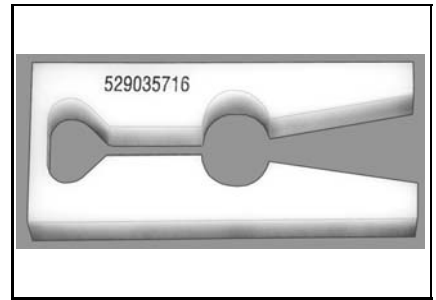

Carbon Dam Compressor
P/N 529 035 716 **Mandatory**
 947 DI engines



SHAFT ALIGNMENT TOOL
P/N 529 035 719 **Mandatory**
 4-TEC engines



Valve spring compressor
P/N 529 035 724 Recommended
 4-TEC engines
 To be used with valve spring compressor
 cup 529 035 764 and 529 036 073

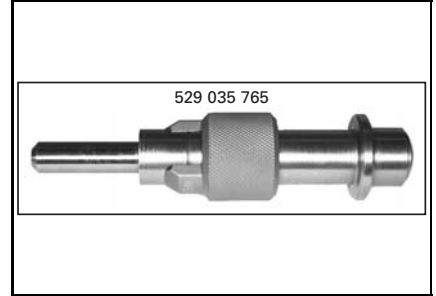

Piston circlip installer
P/N 529 035 765 **Mandatory**
 610/500/1503/V-1000 engines



CRANKSHAFT LOCKING TOOL
P/N 529 035 821 **Mandatory**
 4-TEC 1503 engines

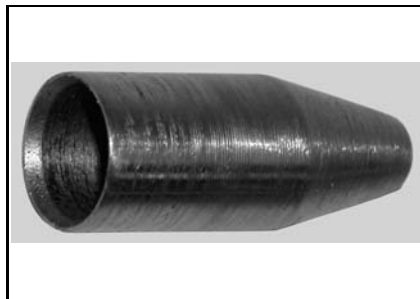

OIL SEAL GUIDE
P/N 529 035 822 **Mandatory**
 4-TEC 1503 engines



Engine lifting ring
P/N 529 035 830 Recommended
 2-stroke engines with 14 mm spark plugs

Engine

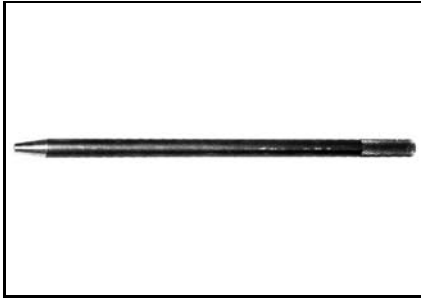

CAMSHAFT LOCKING TOOL

P/N 529 035 839 **Mandatory**

V1000, V1300 & 1503 engines



RING GEAR BLOCKING TOOL

P/N 529 035 846 **Mandatory**

787 & 787 RFI engines



Suction pump

P/N 529 035 880 **Recommended**



TORX ADAPTOR

P/N 529 035 938 **Mandatory**

4-TEC 1503 SC engines

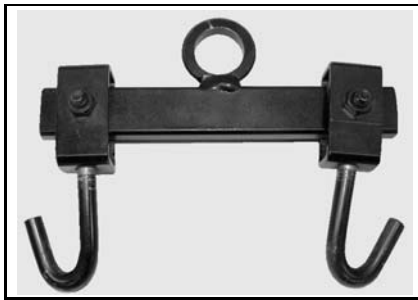

2-stroke engine lifting hook

P/N 529 035 940 **Recommended**

All 2-stroke engines



RING GEAR BLOCKING TOOL

P/N 529 035 946 **Mandatory**

947 & 947 DI engines



SUPPORT PLATE

P/N 529 035 947 **Mandatory**

4-TEC 1503 SC

To hold the supercharger assembly in a vise for disassembly and assembly.



4-pin socket

P/N 529 035 948 **Recommended**

1503 supercharged



BEARING SUPPORT/PUSHER

P/N 529 035 950 **Mandatory**

4-TEC 1503 SC engines

To install bearing of the supercharger ground plate.



Crank shaft bearing puller

P/N 529 036 004 **Recommended**

2 strokes Engine



Supercharger Gear Holder

P/N 529 036 025 **Mandatory**

4-TEC 1503 SC



Supercharger Retaining Key

P/N 529 036 027 **Mandatory**

4-TEC 1503 SC

Engine



Valve spring compressor cup
P/N 529 036 073 Recommended
449, 991, 610/500 engines, Traxter 500
To be used with 529 035 724



Valve Guide Remover 6 mm
P/N 529 036 086 Recommended
1503

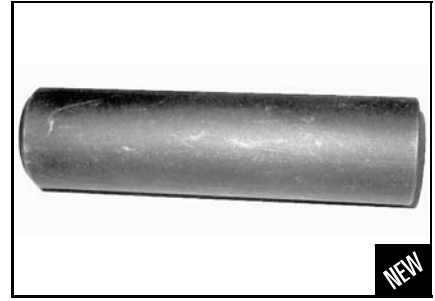

Valve Guide Installer 6 mm
P/N 529 036 087 Recommended
1503, Traxter 500, Quest 610/500

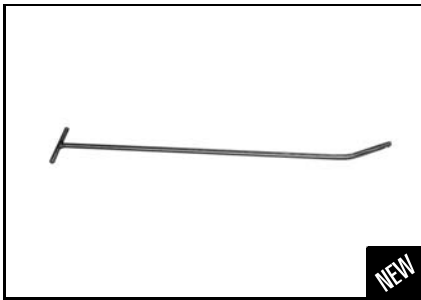

Strap Tool
P/N 529 036 126 Recommended
1503 HO



Piston ring compressor
P/N Snap-on RC 980 Recommended
4-TEC
Not sold by BRP

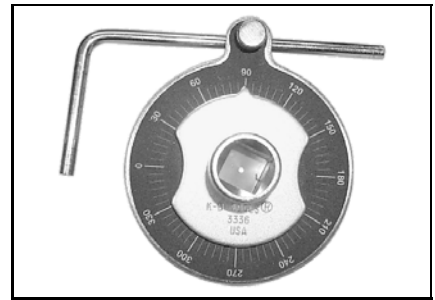

Torque angle gauge
P/N Snap-on TA362 Recommended
Used on most 4-stroke engines.
Not sold by BRP

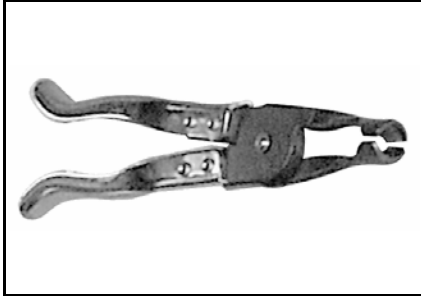

Valve stem seal removal pliers
P/N Snap-on YA 8230 Recommended
1503, 991 engines, DS650
Not sold by BRP

Fuel



Fuel pressure gauge
P/N 529 035 591 Recommended
 787 RFI, 793 SDI & 4-TEC engines
 Replaced by 529 035 709. Spare plastic clip P/N 275500429



Pressure gauge
P/N 529 035 709 **Mandatory**
 Injection type engines
 Use with 529035652, 529035714 & 529036023



Fuel Gauge T Adaptor
P/N 529 035 710 **Mandatory**
 947 DI engines
 Use with gauge P/N 529035709 and P/N 529 035 714.



Pressure Relief Valve Adaptor
P/N 529 035 711 **Mandatory**
 947 DI engines
 Use with gauge P/N 529035709 and P/N 529 035 714.



Air Compressor Adaptor
P/N 529 035 712 **Mandatory**
 947 DI engines
 Use with gauge P/N 529035709 and P/N 529 035 714.

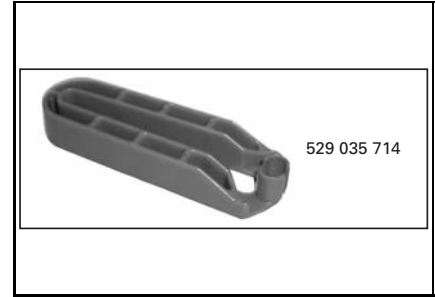

Fuel line remover
P/N 529 035 714 **Mandatory**
 Injection models
 Used also with gauge P/N 529 035 709, 529 035 652 & 529 036 023

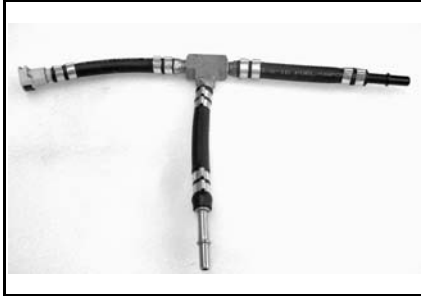

Fuel hose adapter
P/N 529 036 023 Recommended
 Injection type vehicles
 To be used with 529 035 709.
 Replacement clip 513 033 135

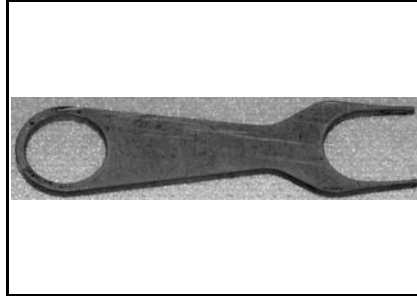

Fuel Hose Connector Tool
P/N 529 036 037 Recommended
 4-TEC 1503
 Disconnect fuel hose



Fuel Module Socket
P/N 529 036 125 Recommended
 1503 2008



Vented cap test adapter
P/N 529 036 141 **Mandatory**
 Vented cap model

Cooling



Flush Kit
P/N 295 500 068 Recommended
 97-98 GTS



Flushing Kit Hose
P/N 295 500 258 Recommended
 All models (except GTS)

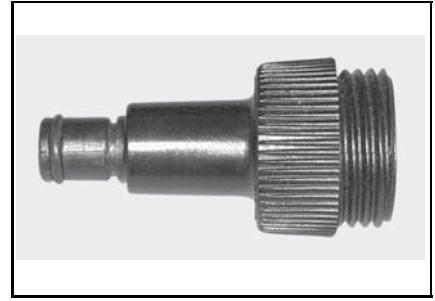

Flushing Adaptor
P/N 295 500 473 Recommended
 All models

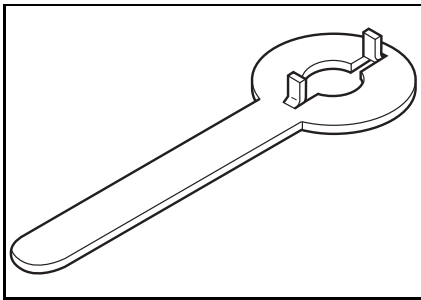

Coolant oil pump gear holder
P/N 420 277 905 **Mandatory**
 717, 583, 670, 599, 699, 779, 809 engine

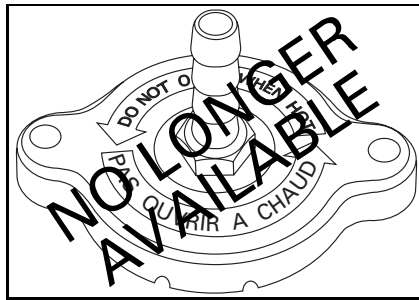

Radiator Cap Pressure Test
P/N 529 021 400 Recommended
 4-TEC models
 Replacement part for item also included in
 kit 861749100



Coolant Pump Seal Pusher
P/N 529 035 823 **Mandatory**
 4-TEC 1503



Test cap
P/N 529 035 991 Recommended
 All models
 To be used with Vacuum/Pressure Pump
 529 021 800.

Electrical



MPI communication cables only
P/N 278 001 052 Recommended
 MPI not included



D.E.S.S. Adaptor
P/N 278 001 978 Recommended
 MY 2003-05 787 RFI models
 To be used with the MPI or MPI-2.



Magneto Harness 4 Pins
P/N 295 000 131 Recommended
 717 engines
 To test the magneto.



Magneto Harness 6 Pins
P/N 295 000 136 Recommended
 787, 787 RF, I 947 & 947 DI engines
 Replaced by 259 035 604



Suction Cup
P/N 295 000 163 Recommended
 To remove gauges.

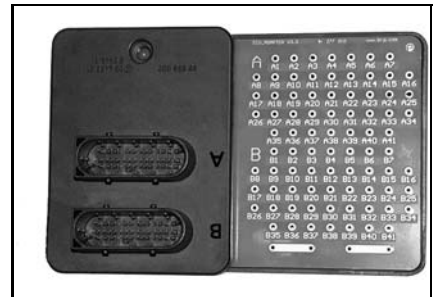

ECM adapter tool
P/N 420 277 010 **Mandatory**
 All models
 All injected 2-TEC & 4-TEC with VDO ECM



MPEM programmer guide
P/N 484 300 139 Recommended
 Guide: how to use hand held programmer
 Has been replaced by B.U.D.S., the MPI
 and recently by the MPI-2.

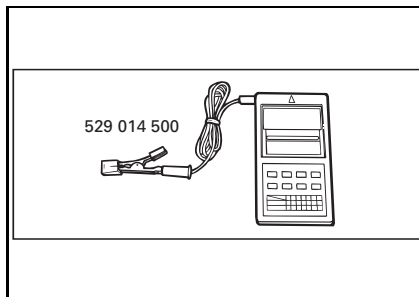

Digital induction tachometer
P/N 529 014 500 Recommended
 All models



Stroboscopic Timing Light
P/N 529 031 900 Recommended
 All 2-stroke



Choke Nut Removal Tool
P/N 529 034 600 Recommended
 Replaced by 529035943

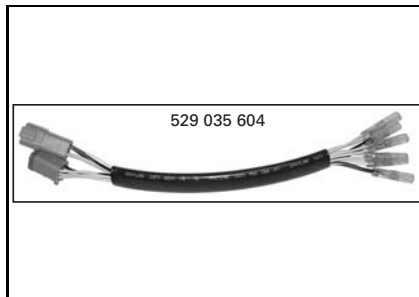

Magneto harness
P/N 529 035 604 Recommended
 787, 787 RFI, 947 & 947 DI engines
 To test magneto.



Diagnostic adaptor for VCK
P/N 529 035 679 Recommended
 To be used with the MPI, connects to 529 035 807.

Electrical



9 Pins to 25 Pins Adaptor
P/N 529 035 681 Recommended
 To connect communication cable P/N 529 035 697 of MPI to older PC.

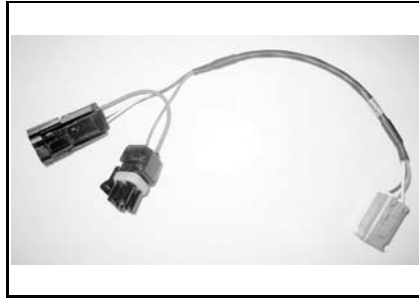

D.E.S.S 4 Pin Adaptor
P/N 529 035 685 Recommended
 1998-2002 787 RFI engines
 Disconnect the D.E.S.S. post and connect in series, then to MPI.



MPI-2 Communication Cable Extension
P/N 529 035 697 Recommended
 Male/female DB9 extension can be purchased at any PC store; max. 25 ft lg.

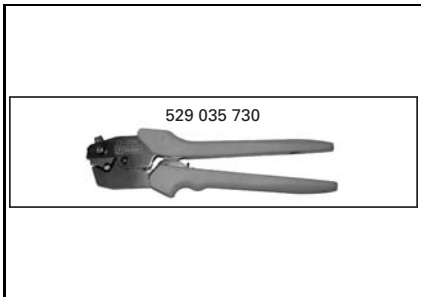

Crimping plier for heavy gage wire
P/N 529 035 730 Recommended
 All models
 Ex.: To crimp battery cable terminals.



Fluke 115 digital multimeter
P/N 529 035 868 Recommended
 All models



MPEM programmer kit
P/N 529 035 878 Recommended
 All 2-stroke models
 No longer sold, replaced by MPI-2, P/N 529 036 018.



D.E.S.S. Adaptor
P/N 529 035 904 **Mandatory**
 Connects to the diagnostic cable of the MPI or MPI-2.



KOSTAL Die
P/N 529 035 906 Recommended
 All models with KOSTAL ECM connectors
 To use with crimping tool 529 035 909 to crimp ECU connectors



AMP die
P/N 529 035 908 Recommended
 All models with AMP connectors
 To use with crimping tool 529 035 909 to crimp Deutsch connectors.



Crimping tool
P/N 529 035 909 Recommended
 To use with compatible die to crimp different connectors

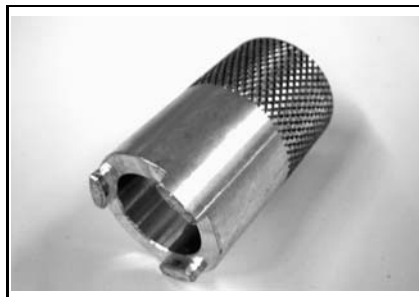

D.E.S.S. Post Remover
P/N 529 035 943 Recommended
 All DESS equipped models



MPI communication kit
P/N 529 035 981 Recommended
 Spare cables are still available. See MPI-2

Electrical

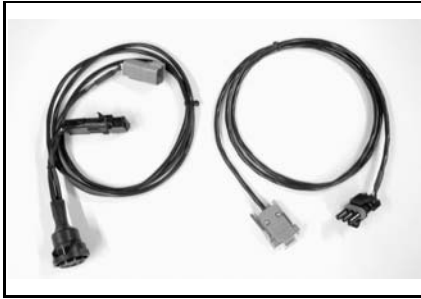

Handheld MEM Programme Cable
P/N 529 035 993 Recommended
 6 pin connector

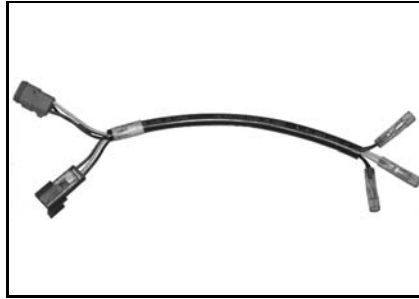

Magneto harness adapter
P/N 529 036 016 Recommended
 1503, 449
 To test the magneto.



787 RFI Timing Tool
P/N 529 036 017 **Mandatory**
 MY 2005, 787 RFI
 To replace temperature sensor during timing procedure.



MPI-2 interface card
P/N 529 036 018 **Mandatory**
 Replaces the MPI.

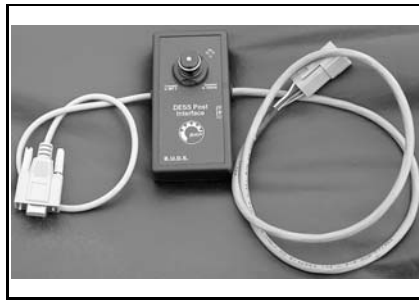

D.E.S.S. Post Interface
P/N 529 036 019 **Mandatory**
 To programm D.E.S.S. keys with the MPI-2.

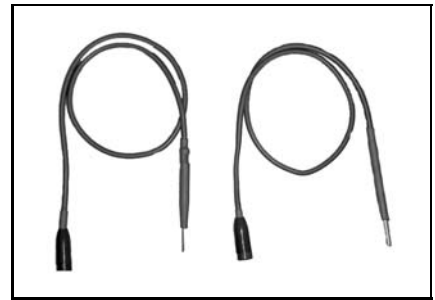

Test probes
P/N 529 036 063 Recommended
 All models
 To back probe various connectors.



MPI-2 diagnostic cable
P/N 710 000 851 **Mandatory**
 All DESS-equipped vehicles

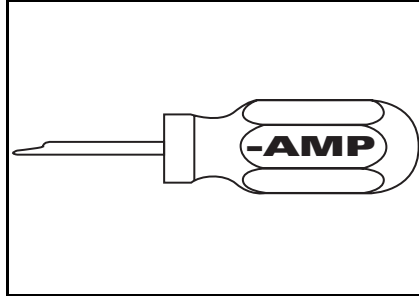

Multilock terminal housing connector ext
P/N AMP 755430-2 Recommended
 Not sold by BRP

Lubrication

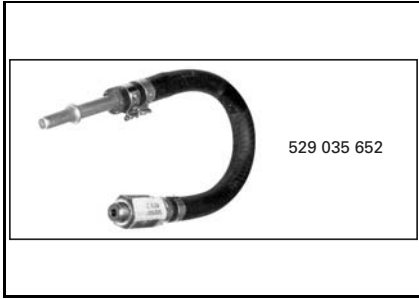

Adapter Hose

P/N 529 035 652

Mandatory

4-TEC engines
Used with 529 035 709.



OIL FILTER COVER EXTRACTOR

P/N 529 036 038

Recommended

4-TEC 1503



Oil Filter Cover Puller

P/N 529 036 057

Recommended

4-TEC 1503
Replaced by 529 036 108

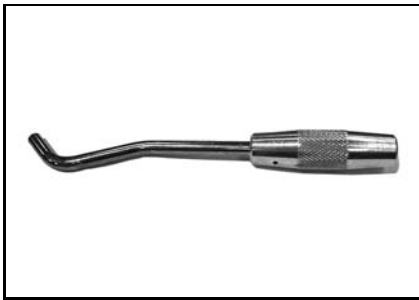

Oil filter cover puller

P/N 529 036 108

Recommended

1503
Used with 529 036 038.



Supercharger Oil Spray jet tool

P/N 529 036 134

Mandatory

1503

Propulsion / Transmission

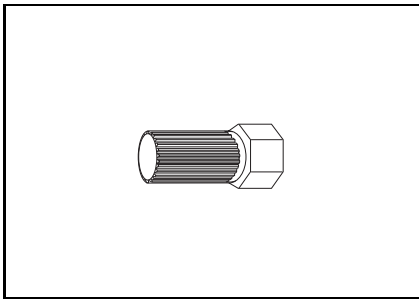

PTO FLYWHEEL/IMPELLER TOOL

P/N 295 000 001

Mandatory

All 2-stroke

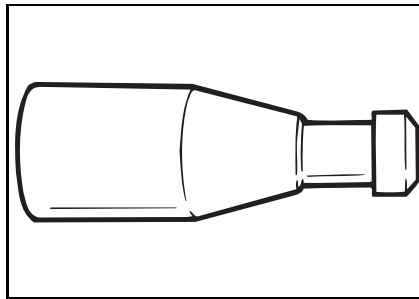

IMPELLER SHAFT GUIDE TOOL

P/N 295 000 002

Mandatory

All 2-stroke models

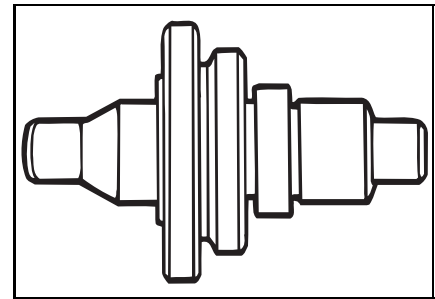

Bearing / Seal Installer Tool

P/N 295 000 107

Mandatory

All 2-stroke engines

Propulsion / Transmission

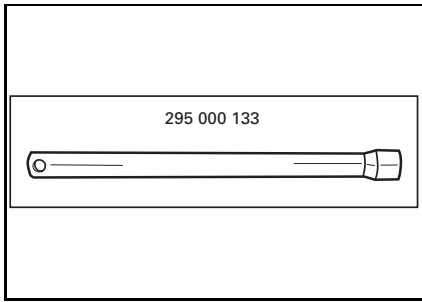

VTS Socket

P/N 295 000 133

Recommended

All VTS equipped

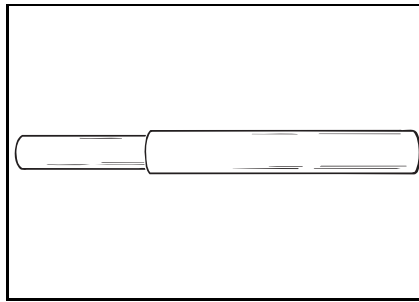

Jet Pump Bearing Remover

P/N 295 000 144

Mandatory

All 2-stroke models



Alignment Adaptor

P/N 295 000 157

Recommended

HX & XP models until 1998

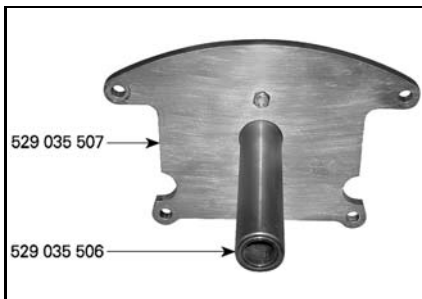

Engine alignment Tool

P/N 529 035 506

Mandatory

All 155.6mm and 139.5mm jet pump

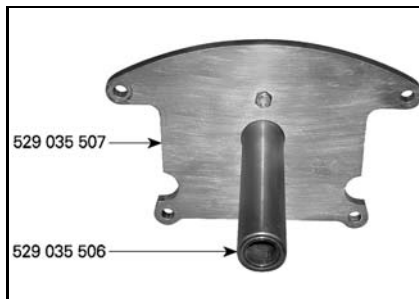

Plate for engine Alignment

P/N 529 035 507

Mandatory

155.6 mm jet pump



Pump Plate

P/N 529 035 508

Mandatory

139.5 mm jet pump
Used with 529 035 506.



Inner Seal Installer

P/N 529 035 609

Mandatory

All 155.6mm jet pump models



Pump Bearing Pusher

P/N 529 035 818

Mandatory

4-TEC 1503 models



SEAL/BEARING PUSHER

P/N 529 035 819

Mandatory

4-TEC 1503 models



Impeller Removing Tool

P/N 529 035 820

Mandatory

4-TEC 1503 NA and BV
Also used to turn the engine.

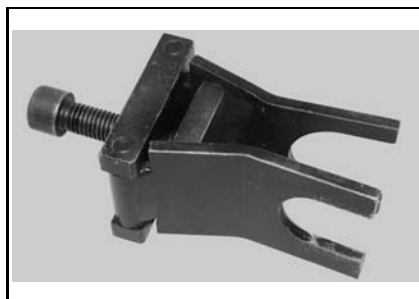

Floating ring tool

P/N 529 035 841

Mandatory

1503 engine without super charger



PTO SUPPORT TOOL

P/N 529 035 842

Mandatory

4-TEC 1503 models

Propulsion / Transmission



Pressure Cap

P/N 529 035 843

Mandatory

4-TEC 1503 models

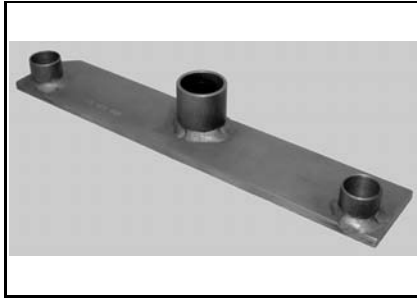

Drive Shaft holder

P/N 529 035 871

Mandatory

4-TEC models, except RXP
Replaced by 529 035 986 (RXP) tool that fits all 4-TEC.

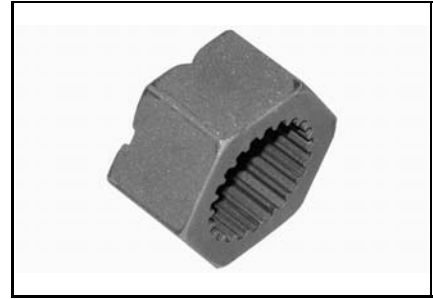

Drive Shaft Adapter

P/N 529 035 892

Mandatory

4-TEC 1503 engines (except BV IC)
Install on drive shaft to turn engine as required.



Impeller shaft installer/ Pusher

P/N 529 035 955

Mandatory

4-TEC Plastic & Aluminum Jet Pump
Tool used to push out impeller shaft and install back bearing in pump.



Impeller Removing Tool

P/N 529 035 956

Mandatory

SC IC Models
Tool used to remove and install impeller

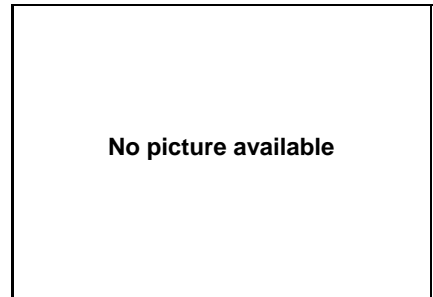

Impeller Remover / Installer

P/N 529 035 984

Recommended

RXP (BV IC)
To remove and install impeller

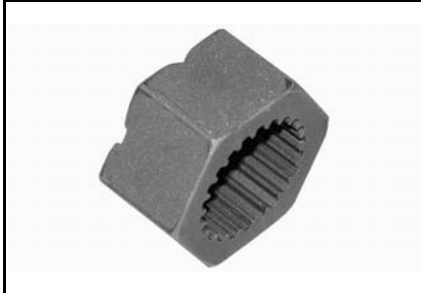

Drive Shaft Adapter

P/N 529 035 985

Mandatory

RXP (BV IC)
To install on driveshaft for turning engine as required.



Drive Shaft Holder

P/N 529 035 986

Mandatory

All 4-TEC 1503
To hold driveshaft in place when using the floating ring tool.



Floating ring tool

P/N 529 035 987

Mandatory

1503 engines with supercharger
Tool used to push the floating ring to expose C-clip on drive shaft

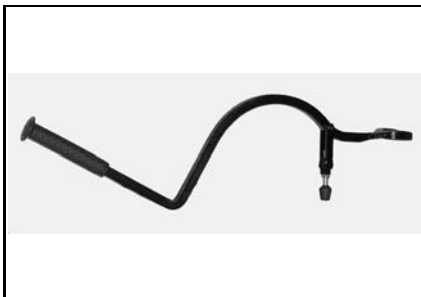

Drive Shaft C-Clip Remover

P/N 529 036 026

Recommended

4-TEC 1503



Floating ring tool III

P/N 529 036 116

Mandatory

??? See JW for all details: to remove the driveshaft floating ring,

Steering

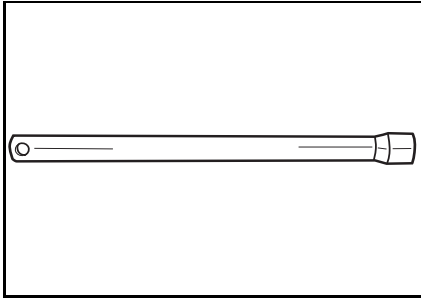

Steering Cable Tool
P/N 295 000 145 Recommended
 All

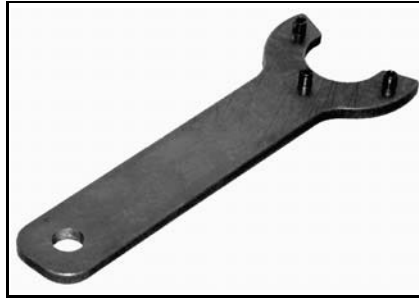

O.P.A.S. CYLINDER NUT WRENCH
P/N 529 035 840 **Mandatory**
 All O.P.A.S. models

Suspension

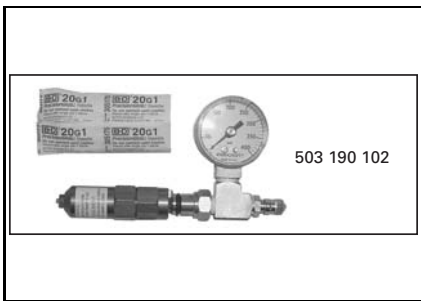

Gas shock filling tool
P/N 503 190 102 Recommended
 T/A shocks
 To be used with P/N 529035570. Spare
 needle P/N 529035930.



Shock preload adjustment wrench
P/N 529 032 900 Recommended

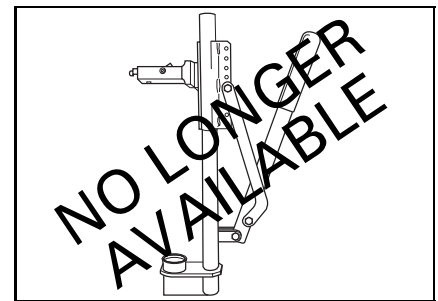

Spring compressor
P/N 529 035 504 Recommended
 No longer sold, replaced by P/N 529 036 007.

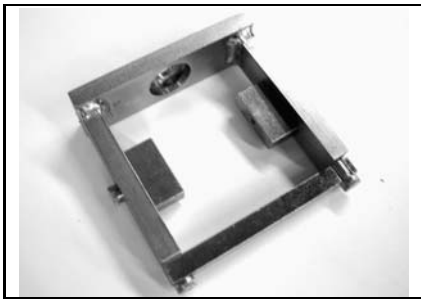

529 035 504 Replacement Component
P/N 529 035 551 Recommended
 HX & XP
 To easily remove HX & XP suspension.

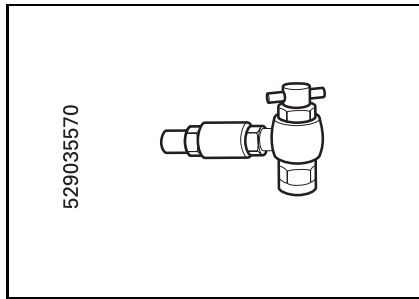

Shock filling valve
P/N 529 035 570 Recommended
 T/A shocks



Spring Remover
P/N 529 036 007 Recommended
 All models
 To remove coil spring from shock.

Various

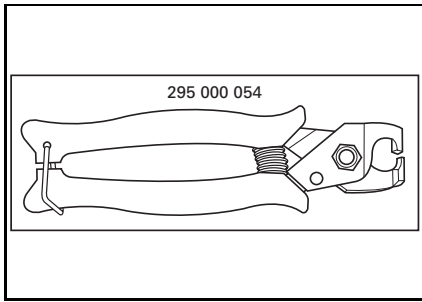

Caillau pliers

P/N 295 000 054

Mandatory

All models

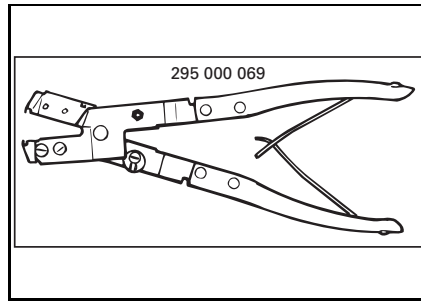

Oetiker Pliers

P/N 295 000 069

Recommended

All models

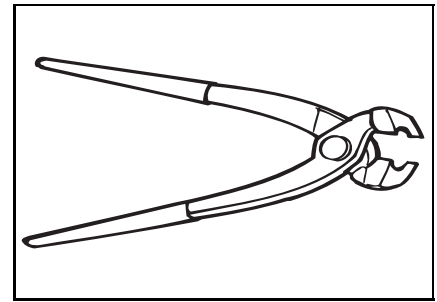

Oetiker pliers

P/N 295 000 070

Recommended

All models

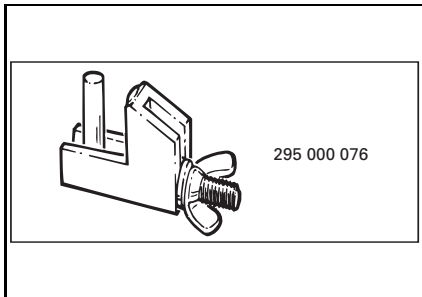

Small hose pincher

P/N 295 000 076

Recommended

All models

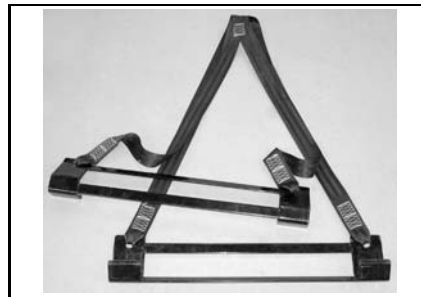

LIFT KIT

P/N 295 100 204

Recommended

LRV DI

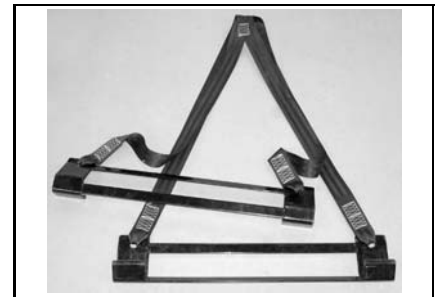

LIFT KIT

P/N 295 100 205

Recommended

4-TEC

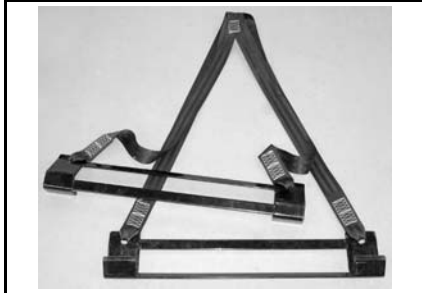

LIFT KIT

P/N 295 100 206

Recommended

All 2-stroke models, except LRV



LEAK SUPPLEMENT KIT

P/N 295 500 780

Mandatory

787 RFI / 947 DI

Kit includes 296 000 024/ 296 000 025/ 296 000 026/ 296 000 027

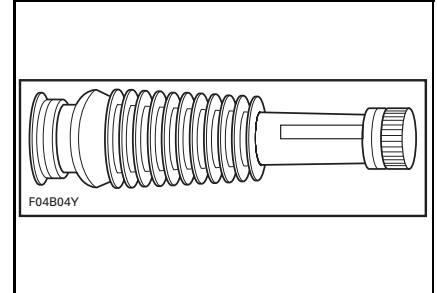

Flexible spout for oil

P/N 414 837 300

Recommended

All models

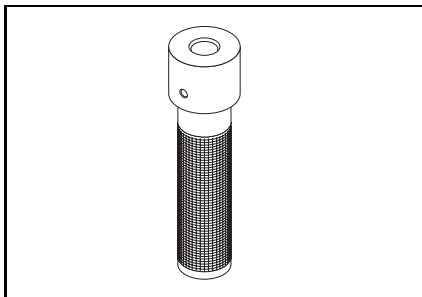

Handle

P/N 420 877 650

Recommended

All models

To be used with many pushers.



Supertitanium drill bit 3/16"

P/N 529 031 800

Recommended

To drill/remove many kinds of rivet.

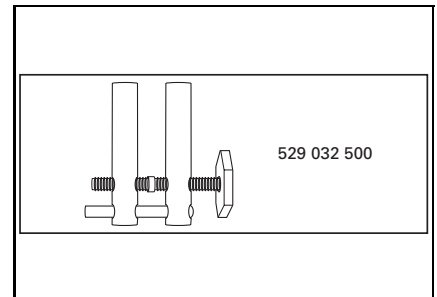

Large hose pincher

P/N 529 032 500

Recommended

All models

Various

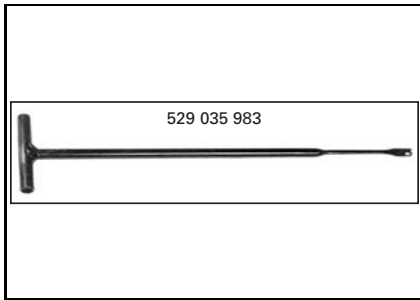

Spring removal tool

P/N 529 035 983

Mandatory

All models

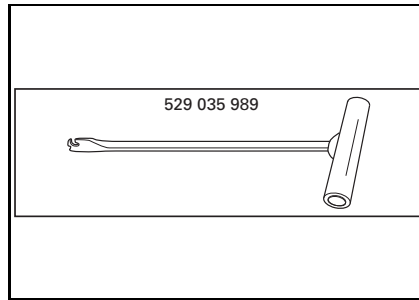

Spring removal tool (small)

P/N 529 035 989

Mandatory



Blind hole bearing puller set

P/N 529 036 117

Recommended

All models

Replaced by 529036056

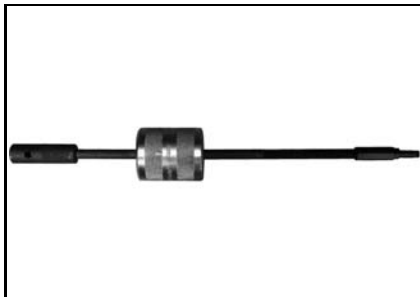

Slide hammer

P/N Snap-on CJ125-6 Recommended

All

No sold by BRP

Index

Tool Part Numbers ... Page

These tools are mandatory

| | | | | | | | |
|------------------------|-----------|------------------------|-----------|------------------------|-----------|------------------------|-----------|
| 278001052 | 12 | 420876569 | 4 | 529035590 | 6 | 529035946 | 8 |
| 278001978 | 12 | 420876605 | 4 | 529035591 | 10 | 529035947 | 8 |
| 290877032 | 2 | 420876609 | 4 | 529035604 | 12 | 529035948 | 8 |
| 290877665 | 2 | 420876904 | 4 | 529035607 | 6 | 529035950 | 8 |
| 295000001 | 15 | 420876965 | 4 | 529035609 | 16 | 529035955 | 17 |
| 295000002 | 15 | 420876979 | 4 | 529035652 | 15 | 529035956 | 17 |
| 295000054 | 19 | 420877414 | 4 | 529035661 | 7 | 529035981 | 13 |
| 295000069 | 19 | 420877635 | 4 | 529035679 | 12 | 529035983 | 20 |
| 295000070 | 19 | 420877650 | 19 | 529035681 | 13 | 529035984 | 17 |
| 295000076 | 19 | 420877740 | 4 | 529035685 | 13 | 529035985 | 17 |
| 295000086 | 2 | 420940755 | 4 | 529035687 | 7 | 529035986 | 17 |
| 295000101 | 2 | 420976235 | 4 | 529035697 | 13 | 529035987 | 17 |
| 295000107 | 15 | 420977475 | 4 | 529035708 | 7 | 529035989 | 20 |
| 295000114 | 2 | 420977480 | 5 | 529035709 | 10 | 529035991 | 11 |
| 295000125 | 2 | 420977490 | 5 | 529035710 | 10 | 529035993 | 14 |
| 295000130 | 2 | 484300139 | 12 | 529035711 | 10 | 529036004 | 8 |
| 295000131 | 12 | 503190102 | 18 | 529035712 | 10 | 529036007 | 18 |
| 295000133 | 16 | 529014500 | 12 | 529035713 | 7 | 529036016 | 14 |
| 295000135 | 2 | 529021400 | 11 | 529035714 | 10 | 529036017 | 14 |
| 295000136 | 12 | 529021800 | 5 | 529035715 | 7 | 529036018 | 14 |
| 295000141 | 2 | 529031800 | 19 | 529035716 | 7 | 529036019 | 14 |
| 295000143 | 2 | 529031900 | 12 | 529035719 | 7 | 529036023 | 10 |
| 295000144 | 16 | 529032500 | 19 | 529035724 | 7 | 529036025 | 8 |
| 295000145 | 18 | 529032900 | 18 | 529035730 | 13 | 529036026 | 17 |
| 295000156 | 2 | 529034600 | 12 | 529035765 | 7 | 529036027 | 8 |
| 295000157 | 16 | 529034800 | 5 | 529035818 | 16 | 529036037 | 10 |
| 295000163 | 12 | 529034900 | 5 | 529035819 | 16 | 529036038 | 15 |
| 295100204 | 19 | 529035000 | 5 | 529035820 | 16 | 529036057 | 15 |
| 295100205 | 19 | 529035100 | 5 | 529035821 | 7 | 529036063 | 14 |
| 295100206 | 19 | 529035503 | 5 | 529035822 | 7 | 529036073 | 9 |
| 295500068 | 11 | 529035504 | 18 | 529035823 | 11 | 529036086 | 9 |
| 295500258 | 11 | 529035505 | 5 | 529035830 | 7 | 529036087 | 9 |
| 295500352 | 2 | 529035506 | 16 | 529035839 | 8 | 529036108 | 15 |
| 295500473 | 11 | 529035507 | 16 | 529035840 | 18 | 529036116 | 17 |
| 295500780 | 19 | 529035508 | 16 | 529035841 | 16 | 529036117 | 20 |
| 414104700 | 3 | 529035513 | 5 | 529035842 | 16 | 529036125 | 10 |
| 414837300 | 19 | 529035533 | 5 | 529035843 | 17 | 529036126 | 9 |
| 420276025 | 3 | 529035541 | 5 | 529035846 | 8 | 529036134 | 15 |
| 420277010 | 12 | 529035542 | 6 | 529035868 | 13 | 529036141 | 10 |
| 420277905 | 11 | 529035543 | 6 | 529035871 | 17 | 710000851 | 14 |
| 420840681 | 3 | 529035547 | 6 | 529035878 | 13 | AMP 755430-2 | 14 |
| 420841201 | 3 | 529035549 | 6 | 529035880 | 8 | Snap-on CJ125-6 | 20 |
| 420841591 | 3 | 529035551 | 18 | 529035892 | 17 | Snap-on RC 980 | 9 |
| 420847220 | 3 | 529035559 | 6 | 529035904 | 13 | Snap-on TA362 | 9 |
| 420876330 | 3 | 529035561 | 6 | 529035906 | 13 | Snap-on YA 8230 | 9 |
| 420876488 | 3 | 529035562 | 6 | 529035908 | 13 | | |
| 420876501 | 3 | 529035563 | 6 | 529035909 | 13 | | |
| 420876502 | 3 | 529035567 | 6 | 529035938 | 8 | | |
| 420876552 | 3 | 529035569 | 6 | 529035940 | 8 | | |
| 420876557 | 3 | 529035570 | 18 | 529035943 | 13 | | |