

INTRODUCTION

This publication governs all warranty labor allowances for 2008 BRP Personal Watercraft.

1. HOW DOES IT WORK

We follow the procedures detailed in the BRP *Watercraft Shop Manual*. The flat rate time is the maximum time allowed for a repair involving any given part. **FLAT RATE TIME IS NOT CUMULATIVE**. You must use the flat rate time given for the longest lasting operation.

NOTE: The *Flat Rate Time Schedule* was prepared by skilled mechanics using the hand tools usually found in workshops and all the special tools mentioned in the *Shop Manual*.

2. COMPILATION

The *Flat Rate Time Schedule* is compiled as follows:

The actual required time to perform the repair plus (+) 30% correction factor up to 3.0 hours or (+) 15% over 3.0 hours time to take into account, among others:

- vehicle handling
- obtaining the parts
- diagnosis
- cleaning
- special compensation (rusted bolts)

3. HOW TO USE IT

Refer to the system you need, locate part or series of parts replaced. List JOB CODE in the appropriate column on claim.

SYSTEM		PAGE
01	ENGINE	4
02	CARBURETOR AND FUEL SYSTEM	14
03	IGNITION	20
04	STARTER	22
05	PROPULSION	24

SYSTEM		PAGE
07	STEERING AND CONTROLS	28
09	BODY	35
10	ELECTRICAL SYSTEM	45
11	CLAIM TYPE 02	47

NOTE: Unless otherwise specified, dismantling order is: top to bottom, exterior to interior, front to rear.

All fractions of hours are in tenths:

- 0.1 = 6 minutes
- 0.2 = 12 minutes, and so on

LEGEND:

- * REQUIRES PRIOR AUTHORIZATION BY DISTRIBUTOR.
- ** INDICATE LABOUR TIME ON LINE "LABOUR ONLY" OF CLAIM.
- *** INDICATE \$\$\$ AMOUNT ON "SUB-CONTRACTED LABOUR" OF CLAIM.

IMPORTANT: Always use the longest flat rate time applicable to the repair performed.

4. JOB REQUIREMENTS

All the flat rate times mentioned in the following pages include the required operations such as: engine timing, connecting rod(s) alignment, cylinder head(s) torque or use of parallel bar, use of ignition tester, piston clearance/ring end gap measurement, crankshaft to crankcase measurement, cylinder honing, engine leak test.

5. ILLUSTRATIONS

The illustrations contained in this manual do not necessarily show every components of a given system as *Parts Catalogs* do. Their purpose is to facilitate recognition of parts related to a flat rate time. **Item numbers on illustrations correspond to the four or five-digit Job Code.**

6. SUGGESTION (FORM REQUEST)

INTRODUCTION

Cette publication détermine le temps de MAIN-D'OEUVRE couvert par la garantie pour les motomarines BRP 2008.

1. UTILISATION DU MANUEL

En procédant de la façon indiquée dans le *Manuel de réparation motomarines* BRP, chaque temps donné représente le maximum permis pour une réparation portant sur cette pièce. **LES TEMPS NE SONT PAS CUMULATIFS.** On doit inscrire le temps donné pour l'opération qui prend le plus de temps.

REMARQUE: Le *Barème de temps à taux fixe* a été préparé par des mécaniciens compétents utilisant les outils que l'on retrouve normalement dans les ateliers de réparation, en plus de tous les outils spéciaux mentionnés dans le *Manuel de réparation*.

2. COMPILATION

Le *Barème de temps à taux fixe* a été établi en compilant le temps nécessaire pour faire la réparation plus (+) un facteur de correction de 30% lorsqu'un travail dure 3.0 heures et moins, ou (+) 15% lorsqu'un travail dure plus de 3.0 heures. Cette compilation comprend, entre autres, les étapes suivantes:

- manutention de la motomarine
- nettoyage
- aller chercher les pièces, essais physiques
- compensation spéciale (boulons rouillés)
- diagnostic

3. UTILISATION DU BARÈME

Se reporter à la section désirée, repérer la pièce ou l'ensemble de pièces remplacées et inscrire le CODE DE TRAVAIL dans la colonne appropriée sur la formule de réclamation.

SYSTÈME	PAGE	
01	MOTEUR	4
02	CARBURATEUR ET SYSTÈME D'ALIMENTATION D'ESSENCE	14
03	ALLUMAGE	20
04	DÉMARREUR	22

SYSTÈME	PAGE	
05	PROPULSION	24
07	DIRECTION ET COMMANDES	28
09	CARROSSERIE	35
10	SYSTÈME ÉLECTRIQUE	45
11	RÉCLAMATION DE TYPE 02	47

REMARQUE: Sauf indication contraire, le démontage doit s'effectuer de haut en bas, de l'extérieur vers l'intérieur, de l'avant vers l'arrière.

Toutes les fractions d'heures sont exprimées en dixièmes:

0.1 = 6 minutes

0.2 = 12 minutes, et ainsi de suite

LÉGENDE:

* AUTORISATION REQUISE AVANT LE REMPLACEMENT.

** INSCRIRE LE TEMPS À LA LIGNE «MAIN-D'OEUVRE SEULEMENT».

*** INSCRIRE LE MONTANT \$\$\$ À LA LIGNE «OUVRAGE SOUS-CONTRACTÉ».

IMPORTANT: Toujours utiliser le temps donné à l'opération qui nécessite le plus de temps.

4. TRAVAUX REQUIS

Tous les temps mentionnés dans les pages suivantes incluent les opérations telles que: réglage du moteur, alignement de la ou des bielles, couple de serrage de la ou des culasses ou utilisation de barres parallèles, utilisation du vérificateur d'allumage, mesure du jet des pistons/jeu en bout des segments, mesure de l'écart entre le vilebrequin et le carter, rectification du cylindre, vérification de fuite du moteur.

5. ILLUSTRATIONS

Contrairement aux *Catalogues de pièces*, les illustrations de ce manuel ne montrent pas nécessairement chacune des pièces qu'elles représentent, leur raison d'être étant plutôt de faciliter la reconnaissance des pièces reliées à un barème de temps à taux fixe. **Les numéros d'items sur les illustrations correspondent aux quatre ou cinq derniers chiffres du code de travail.**

6. SUGGESTION (FORMULAIRE)

2008

Liquid Cooled Engines — Moteurs refroidis par liquide

TABLE	DESCRIPTION	MODEL MODÈLE	ENGINE MOTEUR	SUPERCHARGED COMPRESSEUR	INTERCOOLER REFROIDISSEUR	ELECTRIC V.T.S. CORRECTEUR V.T.S.	FORW/NEUTRAL/REV AVANT/NEUTRE/RENV
1	GTI STD	238A	1503 DT	—	—	—	STD
	GTI STD INTER	238B					
	GTI RENTAL	258A					
	GTI RENTAL INTER	258B					
	GTI SE	248A					
	GTI SE INTER	248B					
	GTI SE	308A/308C	1503 N/A	—	—	—	STD
	GTI SE INTER	308B/308D					
2	RXT	178A/178C	1503 IC	STD	STD	—	STD
	RXT INTER	178B/178D					
3	RXT X	318A	1503 HO	STD	STD	STD	STD
	RXT X INTER	318B					
4	RXP	288A	1503 N/A	—	—	STD	STD
	RXP INTER	288B					
5	RXP IC	218A	1503 IC	STD	STD	STD	STD
	RXP IC INTER	218B					
6	RXP X	328A	1503 HO	STD	STD	STD	STD
	RXP X INTER	328B					
7	GTX	148A	1503 N/A	—	—	—	STD
	GTX INTER	148B					
	WAKE	158A					
	WAKE INTER	158B					
8	GTX	338A	1503 IC	STD	STD	—	STD
	GTX	338B					
	GTX LTD IC	188A					
	GTX LTD IC INTER	188B					
	WAKE IC	268A					
	WAKE IC INTER	268B					

SYSTEM SYSTÈME	CODE	DESCRIPTION	GTI	RXT	RXT X	RXP	RXP IC	RXP X	GTX/ WAKE	GTX/ WAKE IC
			1	2	3	4	5	6	7	8
01	00	NO LABOR INVOLVED AUCUNE MAIN-D'OEUVRE	0	0	0	0	0	0	0	0
01	01	MUFFLER, HOSE, STRAP, RUBBER STRIP SILENCIEUX, BOYAU, SANGLE, BANDE CAOUTCHOUC	0.5	0.6	0.9	0.6	0.6	0.9	0.5	0.6
01	05	EXHAUST MANIFOLD AND/OR BOLT(S) COLLECTEUR D'ÉCHAPPEMENT ET/OU BOULON(S)	1.2	1.3	1.3	1.4	1.4	1.4	1.2	1.3
01 *	08	ENGINE (ASS'Y) REMOVAL AND INSTALLATION DÉPOSE ET INSTALLATION DU MOTEUR (COMPLET)	3.6	4.2	4.2	3.5	3.7	3.7	3.5	4.2
01	12	TEMPERATURE SENSOR CAPTEUR DE TEMPÉRATURE	0.3	0.3	0.3	0.3	0.3	0.3	0.3	0.3
01	14	CYLINDER HEAD AND/OR GASKET CULASSE ET/OU JOINT D'ÉTANCHÉITÉ	3.0	3.0	3.0	3.0	3.0	3.0	3.0	3.0
01	36	EXHAUST OUTLET SORTIE D'ÉCHAPPEMENT	0.7	0.7	0.7	0.7	0.7	0.7	0.6	0.7
01	37	SHORT BLOCK ENSEMBLE CARTER-CYLINDRES	6.9	7.7	7.7	6.9	7.1	7.1	6.9	7.7
01	43	BALANCE SHAFT (ASS'Y) ARBRE D'ÉQUILIBRAGE (COMPLET)	6.8	7.5	7.5	6.8	7.0	7.0	6.8	7.5
01	48	COVER MUFFLER (FRONT) COUVRE SILENCIEUX (AVANT)		0.7	1.0	0.7	0.7	1.0	0.6	0.7
01	52	RESONATOR (RIGHT) RÉSONATEUR (DROIT)	0.5	0.5	0.5	0.5	0.5	0.5	0.5	0.5
01	56	ENGINE RUBBER MOUNTS (REAR OR FRONT) (EACH) TAMPON D'ANCRAGE MOTEUR (AVANT OU ARRIÈRE) (CHACUN)	0.5	0.5	0.5	0.5	0.5	0.5	0.4	0.5
01	57	REAR ENGINE SUPPORT SUPPORT MOTEUR ARRIÈRE	0.5	0.6	0.6	0.6	0.6	0.6	0.5	0.6
01	61	HOSE (FROM PUMP SUPPORT TO HEAD PIPE ASS'Y) BOYAU DU SUPPORT DE POMPE AU TUYAU COLLECTEUR (COMPLET)	0.3	0.3	0.3	0.3	0.3	0.3	0.3	0.3
01	63	SENSOR TEMPERATURE (MUFFLER) CAPTEUR DE TEMPERATURE (SILENCIEUX)	0.3	0.3	0.3	0.3	0.3	0.3	0.3	0.3
01	65	NOISE SENSOR CAPTEUR DE CLIQUETIS	0.9	0.9	0.9	0.9	0.9	0.9	0.9	0.9
01	82	EXHAUST PIPE TUYAU D'ÉCHAPPEMENT SOUDÉ	0.5	0.6	0.9	0.7	0.7	0.9	0.5	0.5
01	83	PISTON, RINGS, CIRCLIP, PIN (1) PISTON, SEGMENTS, ANNEAU DE RETENUE, GOUPILLE (1)	7.0	7.7	7.7	7.0	7.2	7.2	7.0	7.7
01	84	PISTON, RINGS, CIRCLIP, PIN (2) PISTON, SEGMENTS, ANNEAU DE RETENUE, GOUPILLE (2)	7.2	7.9	7.9	7.2	7.4	7.4	7.2	7.9
01	85	PISTON, RINGS, CIRCLIP, PIN (3) PISTON, SEGMENTS, ANNEAU DE RETENUE, GOUPILLE (3)	7.4	8.1	8.1	7.4	7.6	7.6	7.4	8.1
01	86	INLET HOSE (RADIATOR TO PUMP) BOYAU ENTRÉE D'EAU (RADIATEUR À POMPE)	0.5	0.5	0.5	0.5	0.5	0.5	0.5	0.5

SYSTEM SYSTÈME	CODE	DESCRIPTION	GTI	RXT	RXT X	RXP	RXP IC	RXP X	GTX/ WAKE	GTX/ WAKE IC
			1	2	3	4	5	6	7	8
01	87	WATER OUTLET (ENGINE TO RADIATOR) SORTIE D'EAU (MOTEUR AU RADIATEUR)	0.5	0.5	0.5	0.5	0.5	0.5	0.5	0.5
01	88	HOSE FROM MUFFLER LEFT TO MUFFLER RIGHT BOYAU DU SILENCIEUX GAUCHE AU SILENCIEUX DROIT	0.3	0.3	0.3	0.3	0.3	0.3	0.3	0.3
01	89	ENGINE BLOCK (CRANKCASE) ENSEMBLE MOTEUR (CARTER)	8.6	9.3	9.3	8.6	8.8	8.8	8.6	9.3
01	90	ENGINE BLOCK RESEAL OR SEALANT RESCÈLEMENT DU MOTEUR OU SCELLANT	4.7	5.4	5.4	4.7	4.9	4.9	4.7	5.4
01	92	CRANKSHAFT AND/OR PLAIN BEARING AND/OR RING HALF VILEBREQUIN ET/OU ROULEMENT PLAT ET/OU DEMI-BAGUE	8.1	8.8	8.8	8.1	8.3	8.3	8.1	8.8
01	93	WATER PUMP HOUSING (ASS'Y) AND/OR GASKET BOÎTIER POMPE À EAU (COMPLET) ET/OU JOINT D'ÉTANCHÉITÉ	0.8	1.0	1.0	0.8	1.0	1.0	0.8	1.0
01	94	COOLING RESERVE RÉSERVOIR ANTIGEL	0.3	0.3	0.3	0.3	0.3	0.3	0.3	0.3
01	95	RADIATOR AND/OR FITTING RADIATEUR ET/OU RACCORD DROIT	2.7	2.7	3.0	2.7	2.7	3.0	2.7	2.7
01	96	CAMSHAFT POSITION SENSOR CAPTEUR DE POSITION DE L'ARBRE À CAMES	0.3	0.3	0.3	0.3	0.3	0.3	0.3	0.3
01	97	VALVE COVER AND/OR GASKET COUVERCLE DE SOUPE ET/OU JOINT D'ÉTANCHÉITÉ	0.3	0.3	0.3	0.3	0.3	0.3	0.3	0.3
01	98	CAMSHAFT ARBRE À CAMES	1.1	1.1	1.1	1.1	1.1	1.1	1.1	1.1
01	99	CAMSHAFT GUIDE GUIDE DE L'ARBRE À CAMES	0.6	0.6	0.6	0.6	0.6	0.6	0.6	0.6
01	174	CAMSHAFT CHAIN CHAÎNE DE L'ARBRE À CAMES	5.4	6.1	6.1	5.4	5.6	5.6	5.4	6.1
01	175	TIMING GEAR PIGNON DE DISTRIBUTION	1.1	1.1	1.1	1.1	1.1	1.1	1.1	1.1
01	176	ROCKER ARM (ASS'Y) AXE DE CULBUTEUR (COMPLET)	0.6	0.6	0.6	0.6	0.6	0.6	0.6	0.6
01	177	EXHAUST VALVE, SPRINGS, SEAL, GUIDE (1) SOUPE D'ÉCHAPPEMENT, RESSORTS, JOINT, GUIDE (1)	1.7	1.7	1.7	1.7	1.7	1.7	1.7	1.7
01	178	INTAKE VALVE, SRINGS, SEAL, GUIDE (1) SOUPE D'ADMISSION, RESSORTS, JOINT, GUIDE (1)	1.7	1.7	1.7	1.7	1.7	1.7	1.7	1.7
01	179	CHAIN GUIDE GUIDE DE CHAÎNE	0.4	0.4	0.4	0.4	0.4	0.4	0.4	0.4
01	180	OUTPUT SLEEVE, SEAL, STOP SLEEVE MANCHON DE DÉBIT, JOINT, ARRÊT DU MANCHON	1.7	2.4	2.4	1.7	2.4	2.4	1.7	2.4
01	181	SEAL (OUTPUT SLEEVE) JOINT (MANCHON DE DÉBIT)	1.0	1.8	1.8	1.0	1.8	1.8	1.0	1.8
01	182	OIL RADIATOR AND/OR O-RING RADIATEUR D'HUILE ET/OU JOINT TORIQUE	3.7	3.7	3.7	3.7	3.7	3.7	3.7	3.7

SYSTEM SYSTÈME	CODE	DESCRIPTION	GTI	RXT	RXT X	RXP	RXP IC	RXP X	GTX/ WAKE	GTX/ WAKE IC
			1	2	3	4	5	6	7	8
01	183	OIL PUMP COVER AND/OR SHAFT AND/OR ROTOR (REAR) COUVERCLE DE LA POMPE À L'HUILE ET/OU ARBRE ET/OU ROTOR (ARRIÈRE)	2.2	3.2	3.3	2.2	2.7	2.8	2.2	3.2
01	184	OIL PUMP HOUSING AND/OR ALL PARTS (FRONT) BOÎTIER DE LA POMPE À HUILE ET/OU TOUTES LES PIÈCES (AVANT)	1.2	1.2	1.2	1.4	1.6	1.6	1.2	1.2
01	186	OIL SEPARATOR HOUSING AND/OR GASKET BOÎTIER SÉPARATEUR D'HUILE ET/OU JOINT D'ÉTANCHÉITÉ	0.9	0.9	0.9	1.1	1.3	1.3	0.9	0.9
01	189	OIL PRESSURE SWITCH INTERRUPTEUR DE PRESSION D'HUILE	0.3	0.6	0.6	0.6	0.6	0.6	0.3	0.6
01	190	PTO HOUSING AND/OR GASKET BOÎTIER PDM ET/OU JOINT D'ÉTANCHÉITÉ	2.1	3.1	3.2	2.6	2.8	2.9	2.1	3.1
01	191	CHAIN TENSION GUIDE GUIDE DE TENSION DE CHAÎNE	5.4	6.1	6.1	5.4	5.6	5.6	5.4	6.1
01	192	CHAIN TENSIONER (ASS'Y) TENDEUR DE CHAÎNE (COMPLET)	0.3	0.3	0.3	0.3	0.3	0.3	0.3	0.3
01	193	OIL SIEVE (PTO) TAMIS D'HUILE (PDM)	2.1	3.1	3.2	2.6	2.8	2.9	2.1	3.1
01	194	OIL FILTER AND/OR O-RING FILTRE À HUILE ET/OU JOINT TORIQUE	0.3	0.3	0.3	0.3	0.3	0.3	0.3	0.3
01	195	VALVE SEAT SLEEVE, PISTON, SPRING, PLUG AND O-RING MANCHON DE SIÈGE DE SOUPE, PISTON, RESSORT, BOUCHON ET JOINT TORIQUE	2.2	3.2	3.3	2.7	2.9	3.0	2.2	3.2
01	250	CRANKSHAFT POSITION SENSOR (CPS) CAPTEUR POSITION DU VILEBREQUIN (CPV)	0.6	0.6	0.6	0.6	0.6	0.6	0.6	0.6
01	251	PRESSURE VALVE (ASS'Y) SOUPE DE PRESSURISATION (COMPLET)	0.3	0.3	0.3	0.3	0.3	0.3	0.3	0.3
01	255	EXHAUST/INLET VALVES AND/OR SPRINGS AND/OR SEALS (4) VALVES D'ÉCHAPPEMENT/D'ADMISSION ET/OU RESSORTS ET/OU ANNEAUX (4)	2.2	2.2	2.2	2.2	2.2	2.2	2.2	2.2
01	256	EXHAUST/INLET VALVES AND/OR SPRINGS AND/OR SEALS (8) VALVES D'ÉCHAPPEMENT/D'ADMISSION ET/OU RESSORTS ET/OU ANNEAUX (8)	2.6	2.6	2.6	2.6	2.6	2.6	2.6	2.6
01	257	EXHAUST/INLET VALVES AND/OR SPRINGS AND/OR SEALS (12) VALVES D'ÉCHAPPEMENT/D'ADMISSION ET/OU RESSORTS ET/OU ANNEAUX (12)	3.0	3.0	3.0	3.0	3.0	3.0	3.0	3.0
01	260	COOLANT HOSE (WATER PUMP HOUSING TO ENGINE) BOYAU DE REFROIDISSEMENT (BOÎTIER DE LA POMPE À EAU AU MOTEUR)	0.5	0.7	0.7	0.5	0.7	0.7	0.5	0.7
01	264	LONG BLOCK ENSEMBLE CARTER-CYLINDRE-CULASSE	5.0	5.6	5.6	4.9	5.3	5.3	4.9	5.6

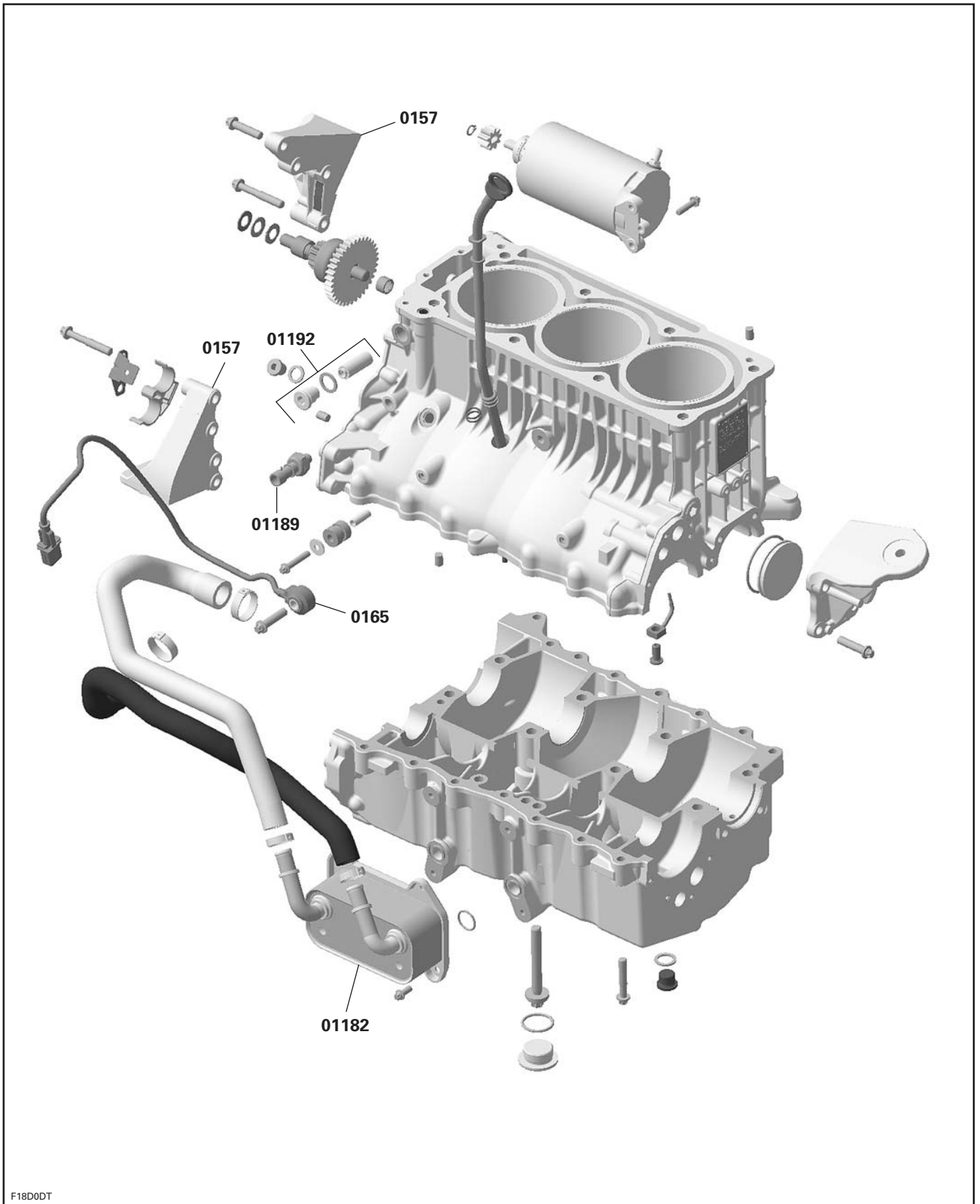

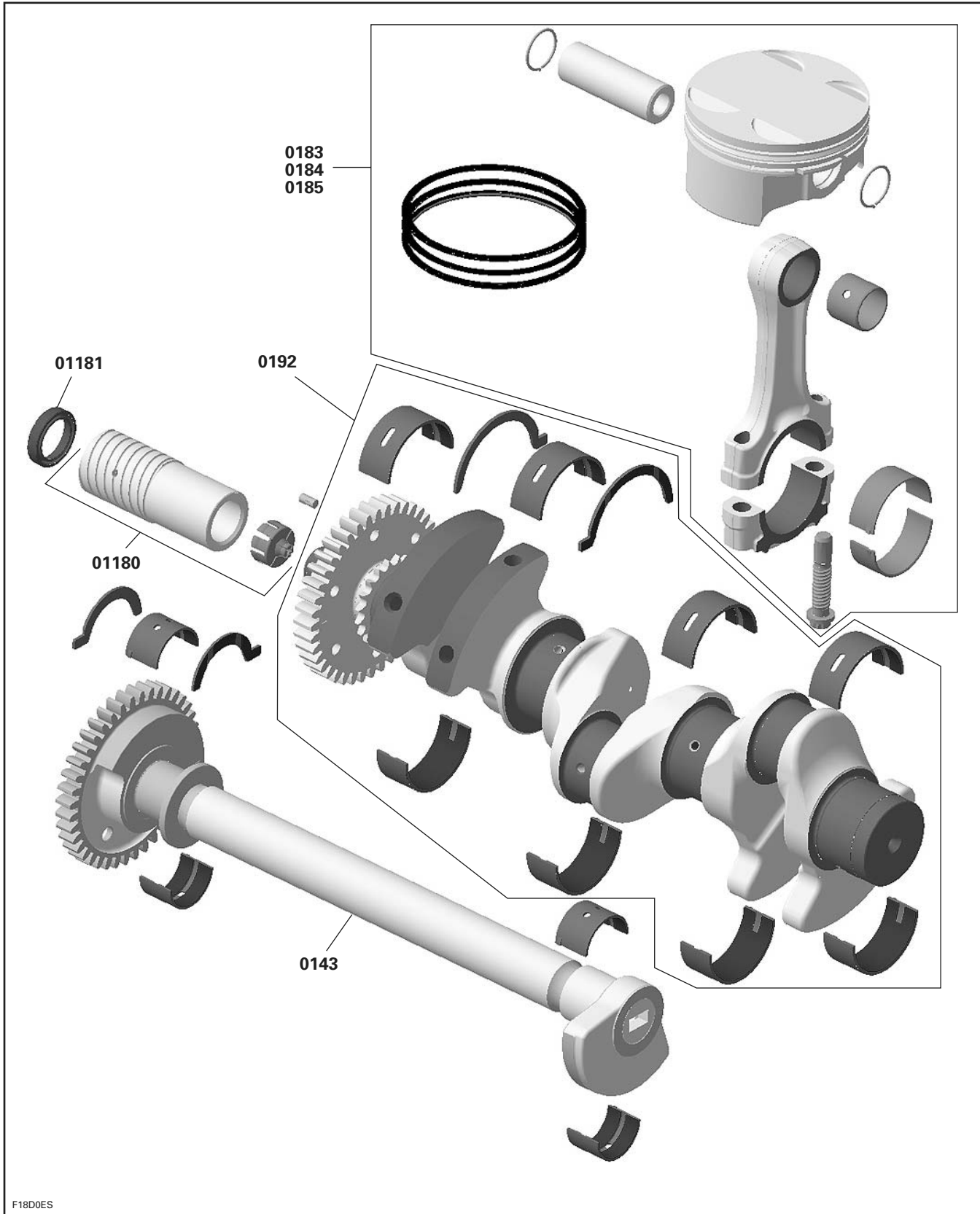

F18D0ES

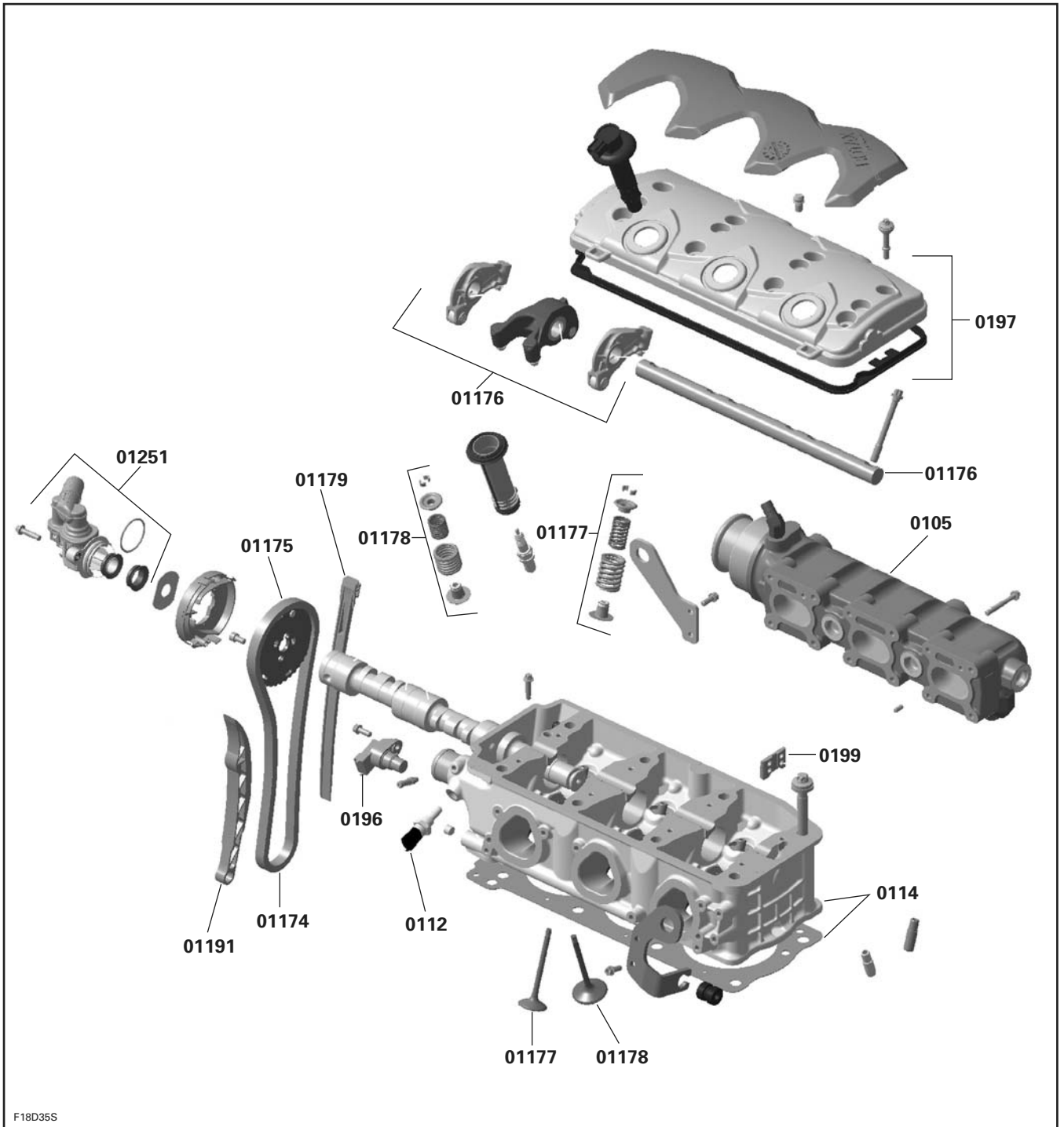

01 ENGINE MOTEUR

SYSTEM/SYSTÈME

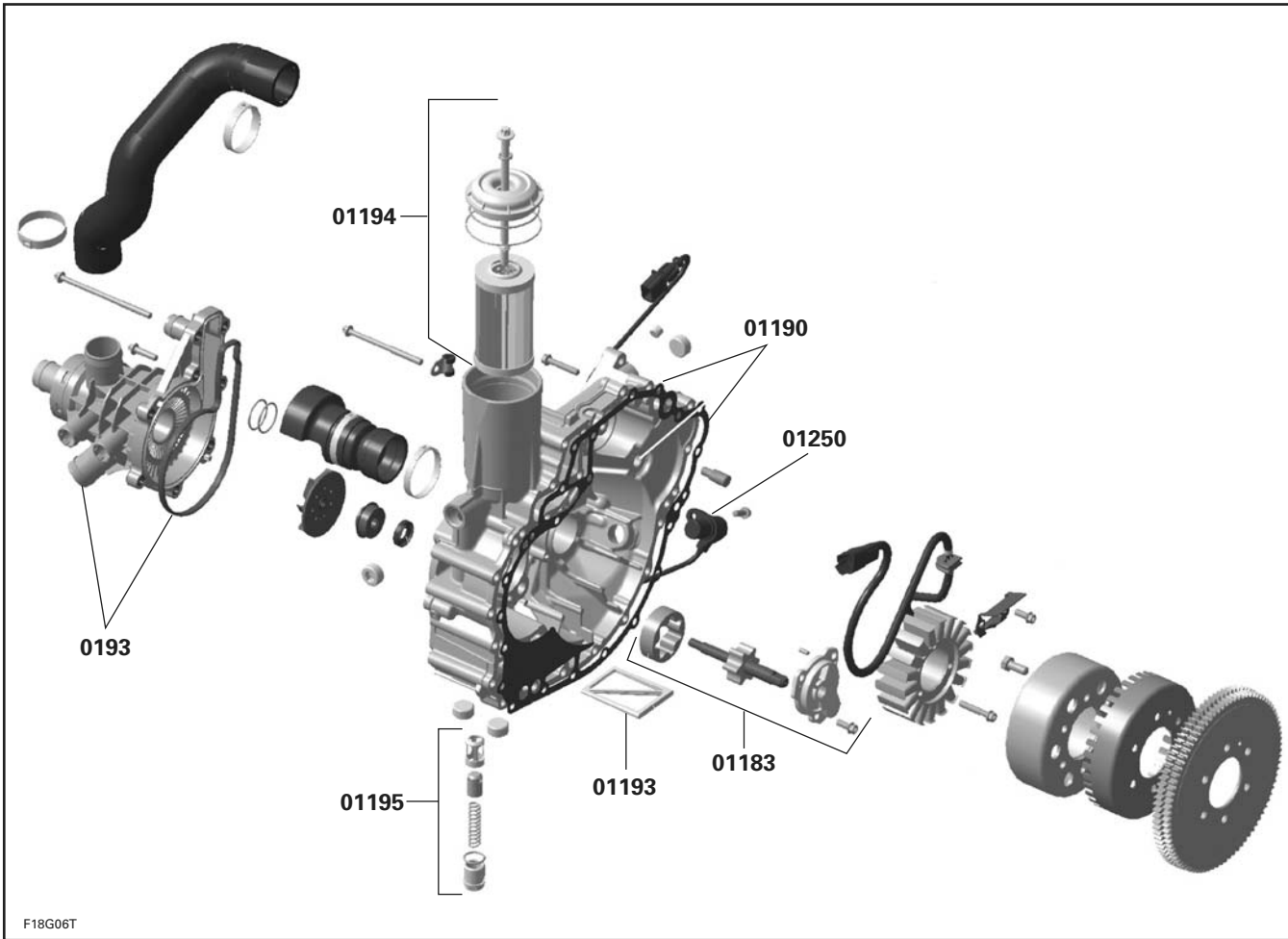

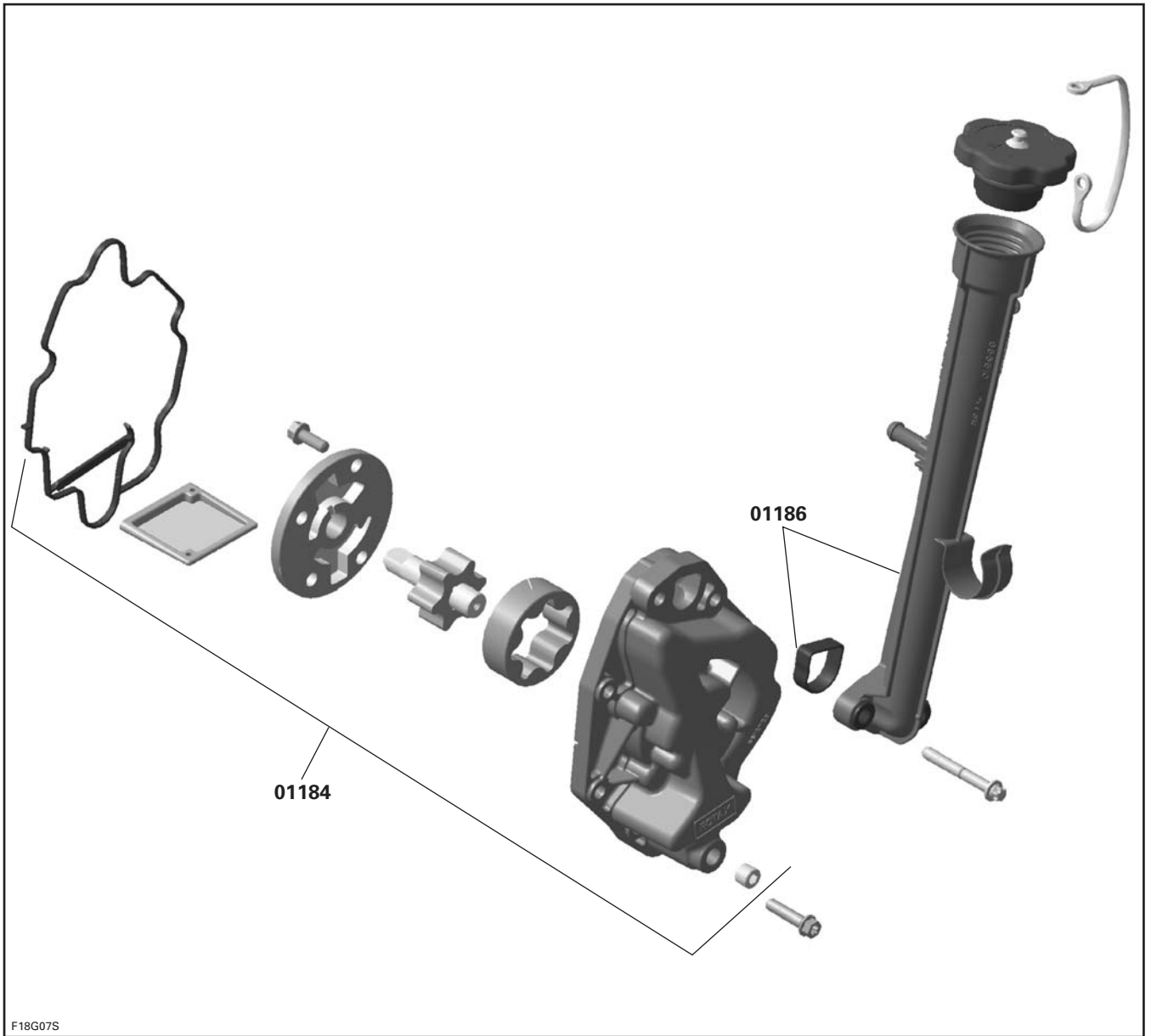

F18G07S

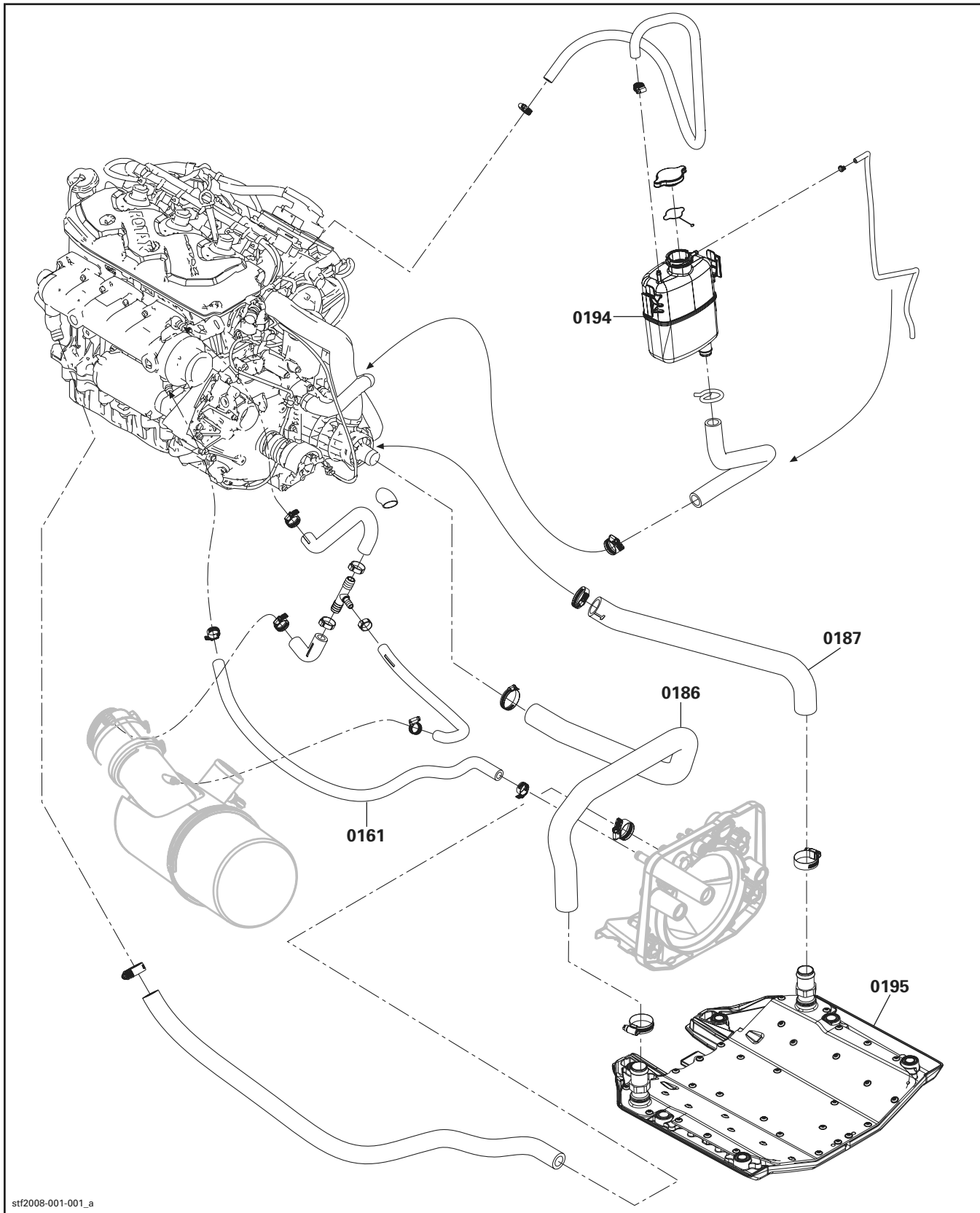

stf2008-001-001_a

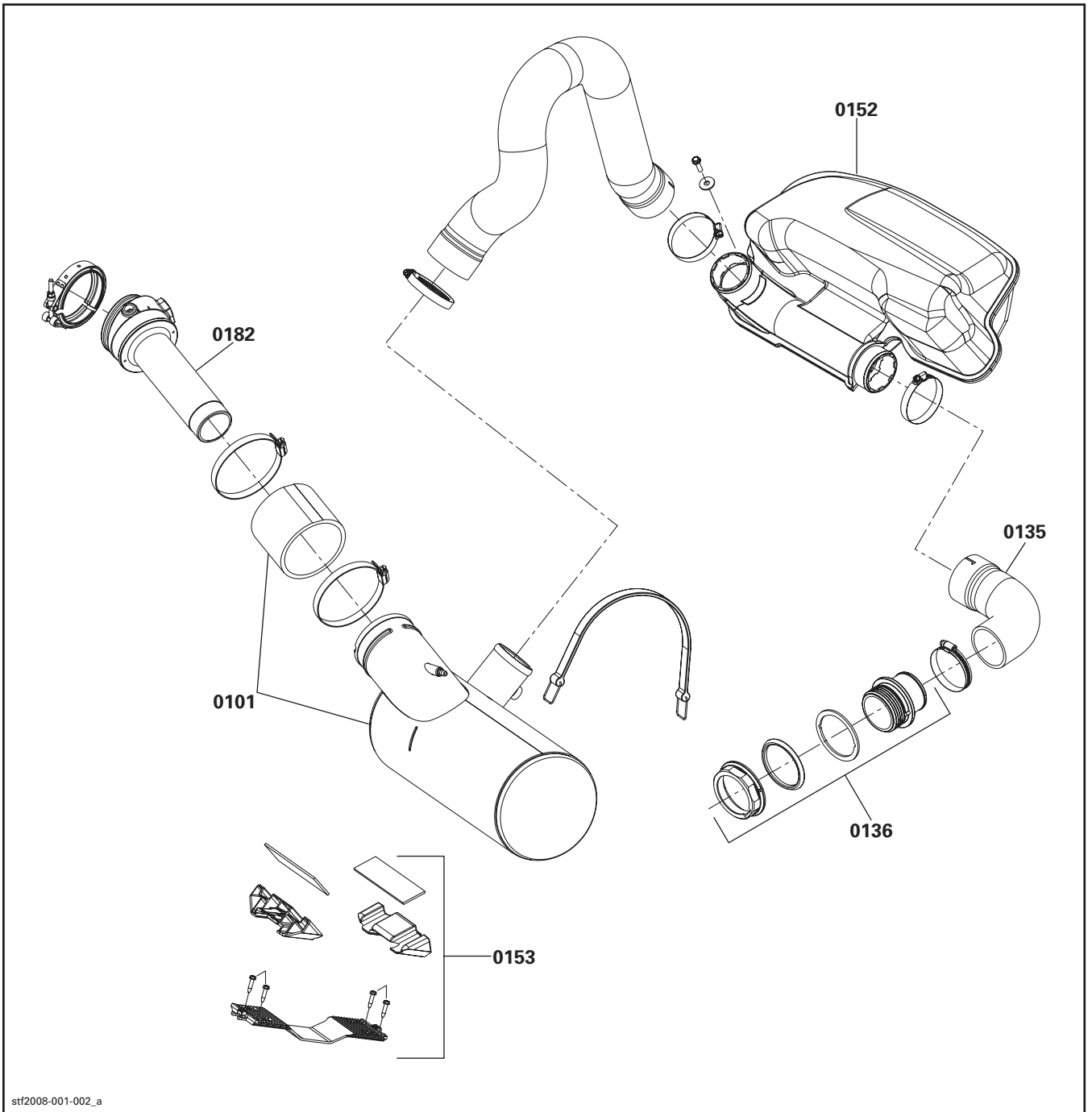

stf2008-001-002_a

CARBURETOR AND FUEL SYSTEM CARBURATEUR ET SYSTÈME D'ALIMENTATION D'ESSENCE

SYSTEM SYSTÈME	CODE	DESCRIPTION	GTI	RXT	RXT X	RXP	RXP IC	RXP X	GTX/ WAKE	GTX/ WAKE IC
			1	2	3	4	5	6	7	8
02	00	NO LABOR INVOLVED AUCUNE MAIN-D'OEUVRE	0	0	0	0	0	0	0	0
02	01	REMOVAL AND/OR INSTALLATION OF AIR SILENCER DÉPOSE ET/OU INSTALLATION SILENCIEUX ADMISSION D'AIR	0.4	0.4	0.4	0.5	0.5	0.5	0.4	0.4
02	05	THROTTLE CABLE (1) CÂBLE D'ACCÉLÉRATEUR (1)	0.7	0.7	0.7	0.7	0.7	0.7	0.7	0.7
02	26	FUEL TANK CAP AND/OR SEAL BOUCHON DU RÉSERVOIR À ESSENCE ET/OU ANNEAU	0.3	0.3	0.3	0.3	0.3	0.3	0.3	0.3
02	27	FUEL TANK FILLER NECK AND/OR GASKET AND/OR CHAIN GOULOT DE REMPLISSAGE ET/OU JOINT D'ÉTANCHÉITÉ ET/OU CHAÎNE	0.4	0.4	0.4	0.4	0.4	0.4	0.4	0.4
02	29	FUEL TANK STRAPS (2 OR 4) SANGLES DU RÉSERVOIR À ESSENCE (2 OU 4)	0.5	0.3	0.3	0.3	0.3	0.3	0.3	0.3
02	31	FUEL TANK RÉSERVOIR À ESSENCE	4.7	5.3	5.3	4.8	5.0	5.0	4.6	5.3
02	35	VENT CHECK VALVE (EACH) SOUPAPE D'ARRÊT DU SYSTÈME DE VENTILATION (CHACUNE)	0.3	0.3	0.3	0.3	0.3	0.3	0.3	0.3
02	36	FUEL TANK HOSE (FROM FILLER NECK TO FUEL TANK) BOYAU À ESSENCE (GOULOT AU RÉSERVOIR)	0.3	0.3	0.3	0.3	0.3	0.3	0.3	0.3
02	63	THROTTLE BODY (ASS'Y) CARTER D'ACCÉLÉRATEUR (COMPLET)	0.6	0.6	0.6	0.6	0.6	0.6	0.6	0.6
02	64	INJECTOR INJECTEUR	0.4	0.4	0.4	0.4	0.4	0.4	0.4	0.4
02	65	THROTTLE SENSOR (EACH) CAPTEUR DE POSITION D'ACCÉLÉRATEUR (CHACUN)	0.7	0.9	0.9	0.8	0.8	0.8	0.7	0.9
02	66	FUEL PUMP MODULE MODULE POMPE À ESSENCE	0.4	0.4	0.4	0.4	0.4	0.4	0.4	0.4
02	67	FUEL PUMP INLET FILTER FILTRE DU CONDUIT D'ENTRÉE DE POMPE À ESSENCE	0.4	0.4	0.4	0.4	0.4	0.4	0.4	0.4
02	69	FUEL RAIL RAIL D'ESSENCE	0.3	0.3	0.3	0.3	0.3	0.3	0.3	0.3
02	73	AIR TEMPERATURE SENSOR (CARBURETOR ADAPTOR) CAPTEUR DE TEMPÉRATURE D'AIR (ADAPTATEUR DE CARBURATEUR)	0.3	0.3	0.3	0.3	0.3	0.3	0.3	0.3
02	78	FUEL FEEDING HOSE (ASS'Y) BOYAU D'ALIMENTATION D'ESSENCE (COMPLET)	0.3	0.3	0.3	0.3	0.3	0.3	0.3	0.3
02	84	AIR PRESSURE SENSOR CAPTEUR PRESSION D'AIR	0.3	0.3	0.3	0.3	0.3	0.3	0.3	0.3
02	85	AIR INTAKE (ASS'Y) ADMISSION D'AIR (COMPLET)	0.8	0.8	0.8	0.8	0.8	0.8	0.8	0.8
02	86	IDLE BY-PASS VALVE VALVE DU RALENTI	0.3	0.3	0.3	0.3	0.3	0.3	0.3	0.3

CARBURETOR AND FUEL SYSTEM CARBURATEUR ET SYSTÈME D'ALIMENTATION D'ESSENCE

02
SYSTEM/SYSTÈME

SYSTEM SYSTÈME	CODE	DESCRIPTION	GTI	RXT	RXT X	RXP	RXP IC	RXP X	GTX/ WAKE	GTX/ WAKE IC
			1	2	3	4	5	6	7	8
02	87	COMPRESSOR HOUSING AND/OR BOOSTER AND/OR O-RING LOGEMENT DU COMPRESSEUR ET/OU PROPULSEUR ET/OU JOINT TORIQUE		1.2	1.2		1.2	1.2		1.2
02	88	COMPRESSOR IMPELLER AND/OR BALL BEARING AND/OR O-RING AND/OR STEP COLLAR TURBINE DE COMPRESSEUR ET/OU ROULEMENT À BILLES ET/OU JOINT TORIQUE ET/OU PALIER		1.3	1.3		1.3	1.3		1.3
02	89	COMPRESSOR SHAFT (ASS'Y) AND/OR BALL BEARING AXE DE COMPRESSOR (COMPLET) ET/OU ROULEMENT À BILLES		1.5	1.5		1.5	1.5		1.5
02	90	DRIVE GEAR AND/OR NEEDLE PIN AND/OR SPRING WASHER ENGRENAGE D'ENTRAÎNEMENT ET/OU GOUPILLE À AIGUILLE ET/OU RONDELLE RESSORT		1.2	1.2		1.2	1.2		1.2
02	91	INTERCOOLER AND/OR O-RING REFROIDISSEUR ET/OU JOINT TORIQUE		0.9	0.6		0.9	0.6		0.9
02	92	INTERCOOLER SUPPORT AND/OR ALL PARTS SUPPORT DU REFROIDISSEUR ET/OU TOUTES LES PIÈCES			0.9			0.9		

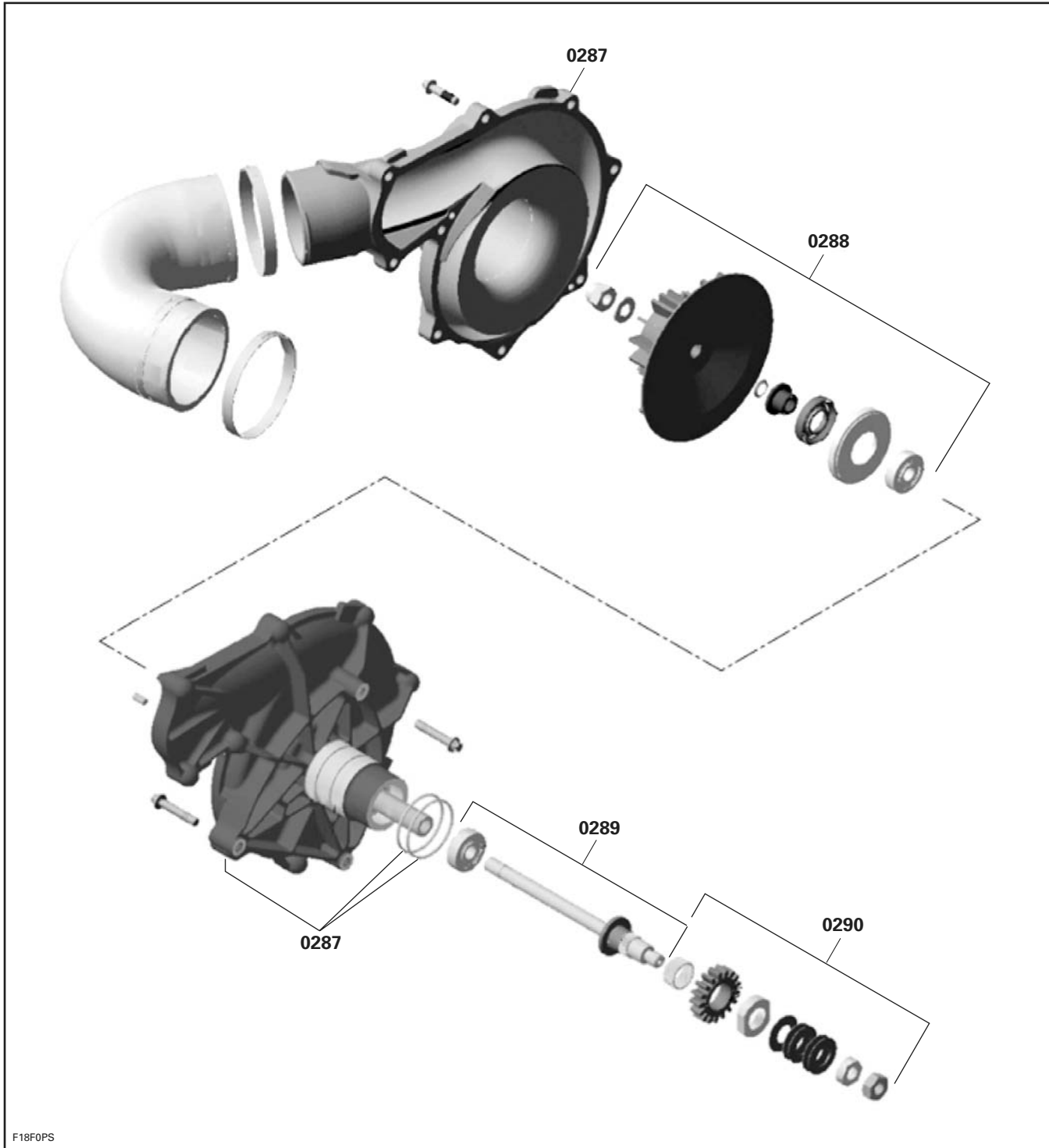

F18F0PS

CARBURETOR AND FUEL SYSTEM CARBURATEUR ET SYSTÈME D'ALIMENTATION D'ESSENCE

02
SYSTEM/SYSTÈME

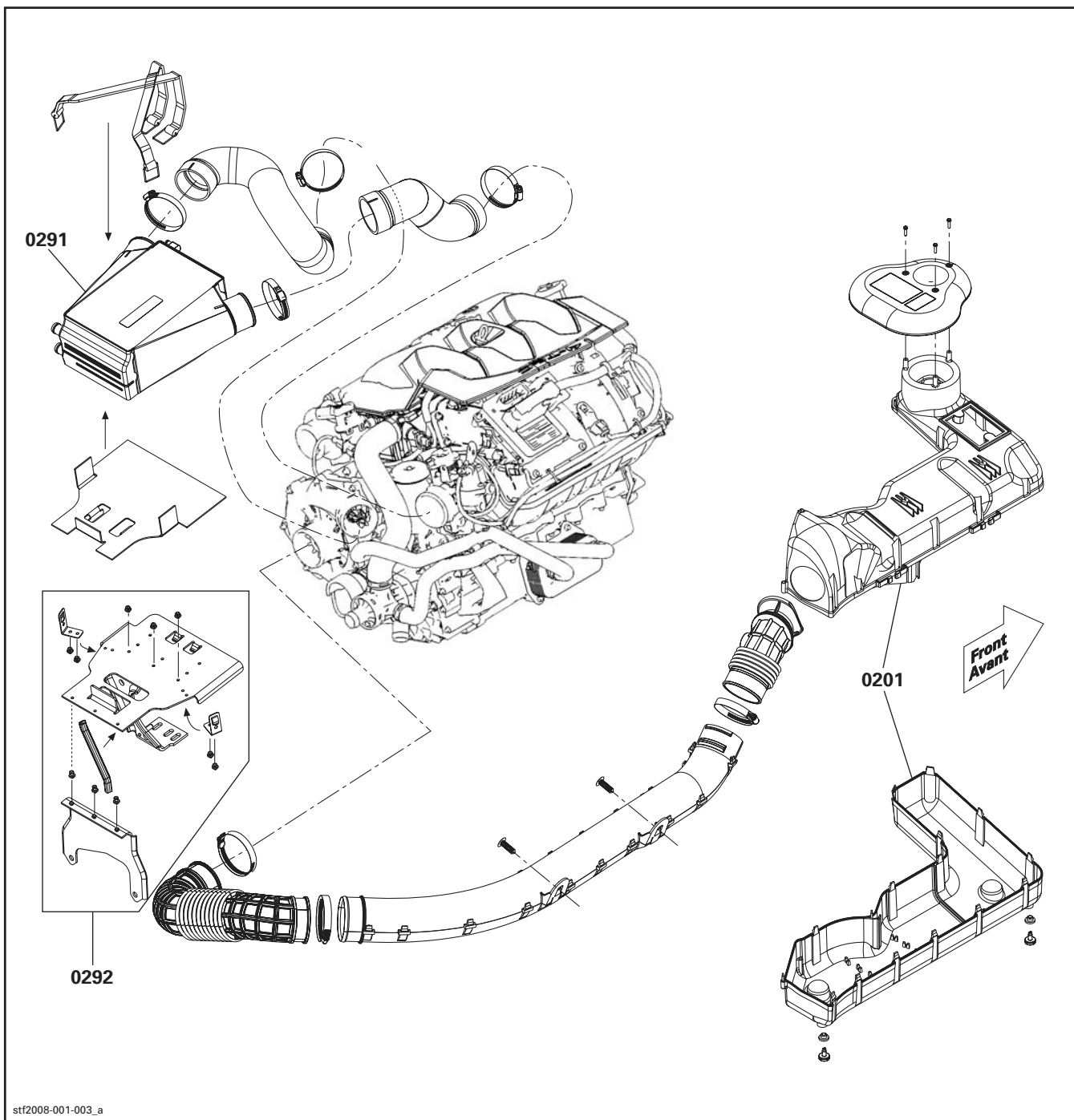

**CARBURETOR AND FUEL SYSTEM
CARBURATEUR ET SYSTÈME D'ALIMENTATION D'ESSENCE**

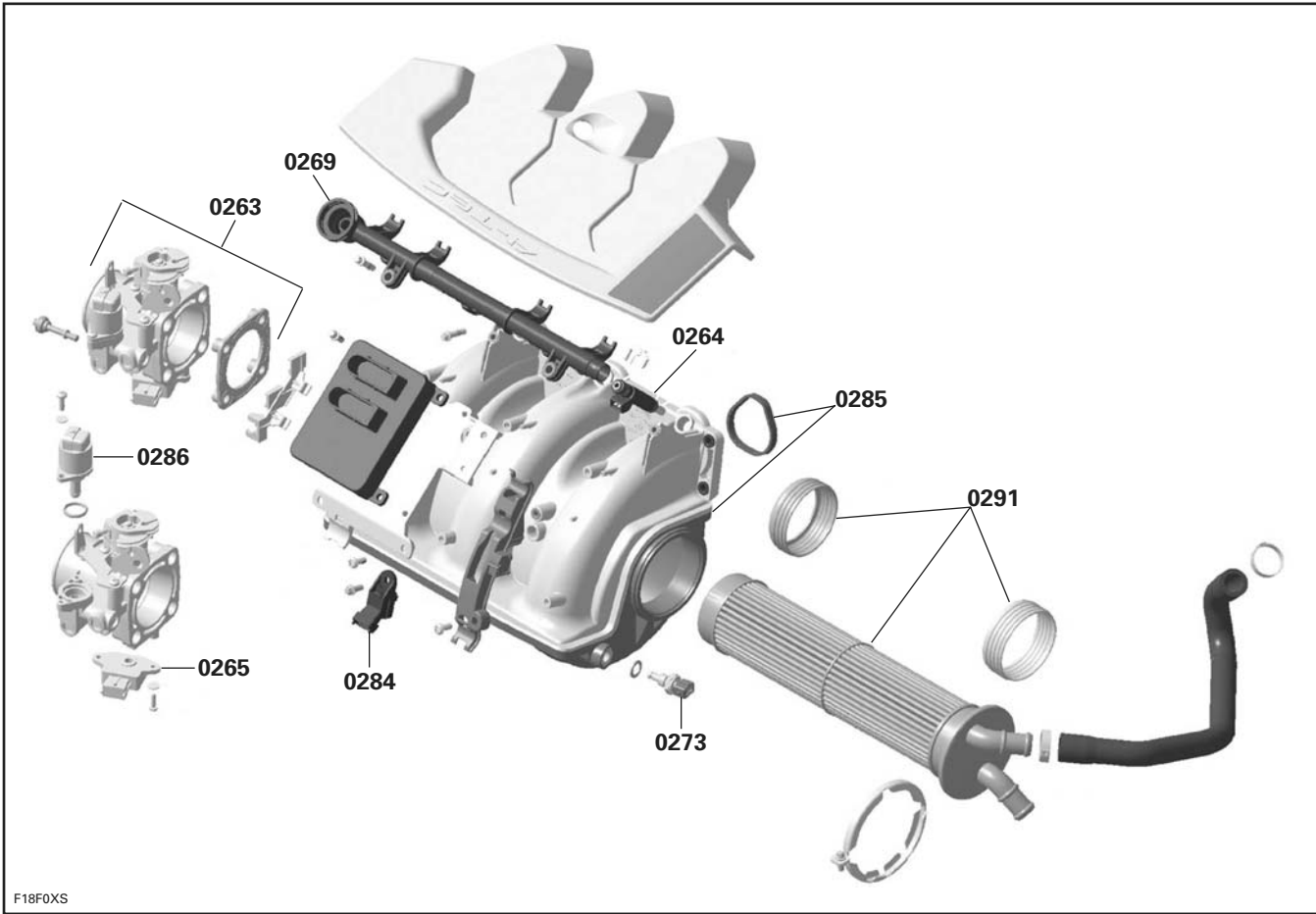

F18F0XS

CARBURETOR AND FUEL SYSTEM CARBURATEUR ET SYSTÈME D'ALIMENTATION D'ESSENCE

02
SYSTEM/SYSTÈME

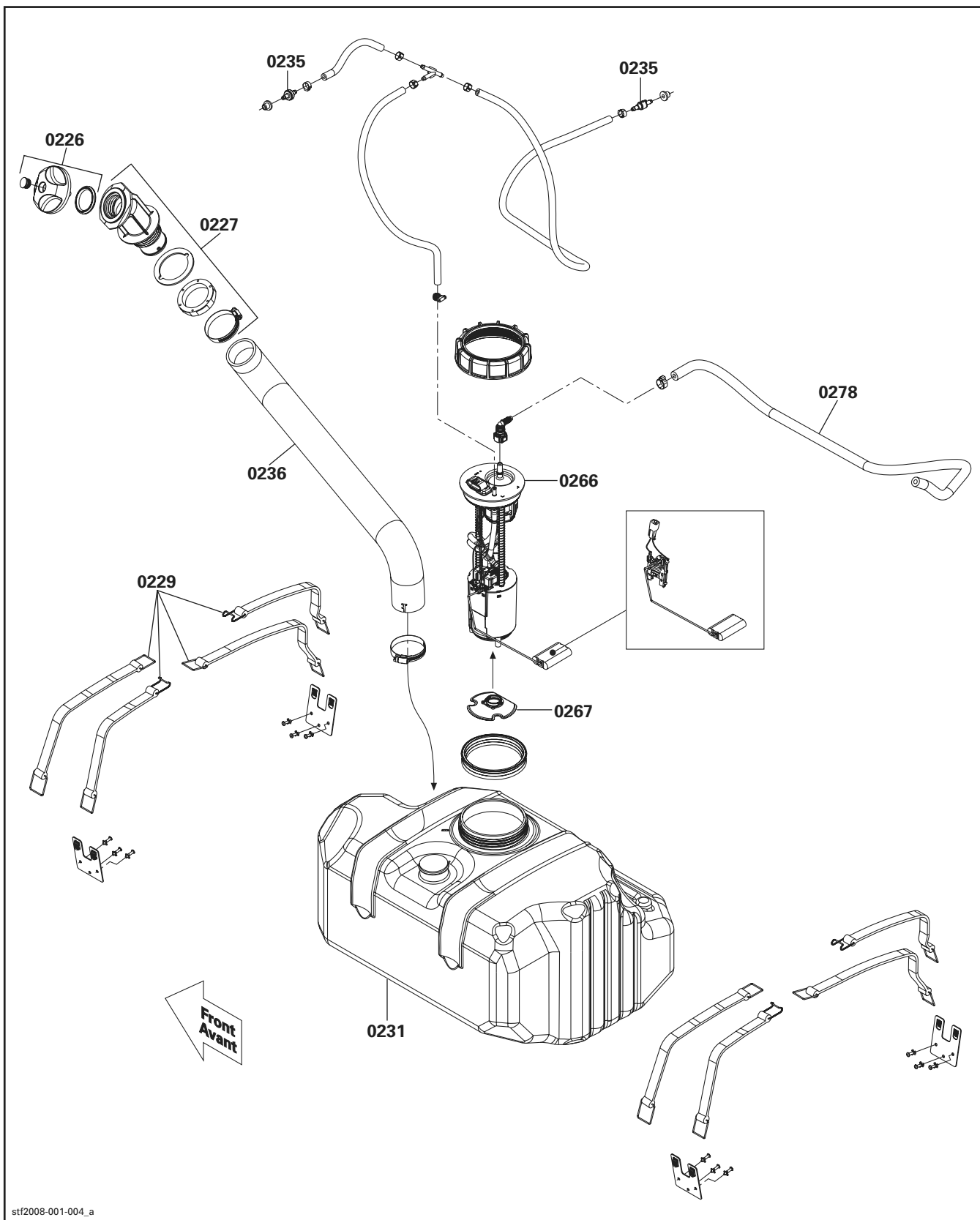

SYSTEM SYSTÈME	CODE	DESCRIPTION	GTI	RXT	RXT X	RXP	RXP IC	RXP X	GTX/ WAKE	GTX/ WAKE IC
			1	2	3	4	5	6	7	8

03	00	NO LABOR INVOLVED AUCUNE MAIN-D'OEUVRE	0	0	0	0	0	0	0	0
03	04	IGNITION COIL BOBINE D'ALLUMAGE	0.3	0.3	0.3	0.3	0.3	0.3	0.3	0.3
03	06	MAGNETO FLYWHEEL VOLANT MAGNÉTIQUE	2.3	3.3	3.4	2.6	3.3	3.4	2.3	3.3
03	07	STATOR PLATE (ASS'Y) PLAQUE ARMATURE (COMPLET)	2.3	3.3	3.4	2.6	3.3	3.4	2.3	3.3

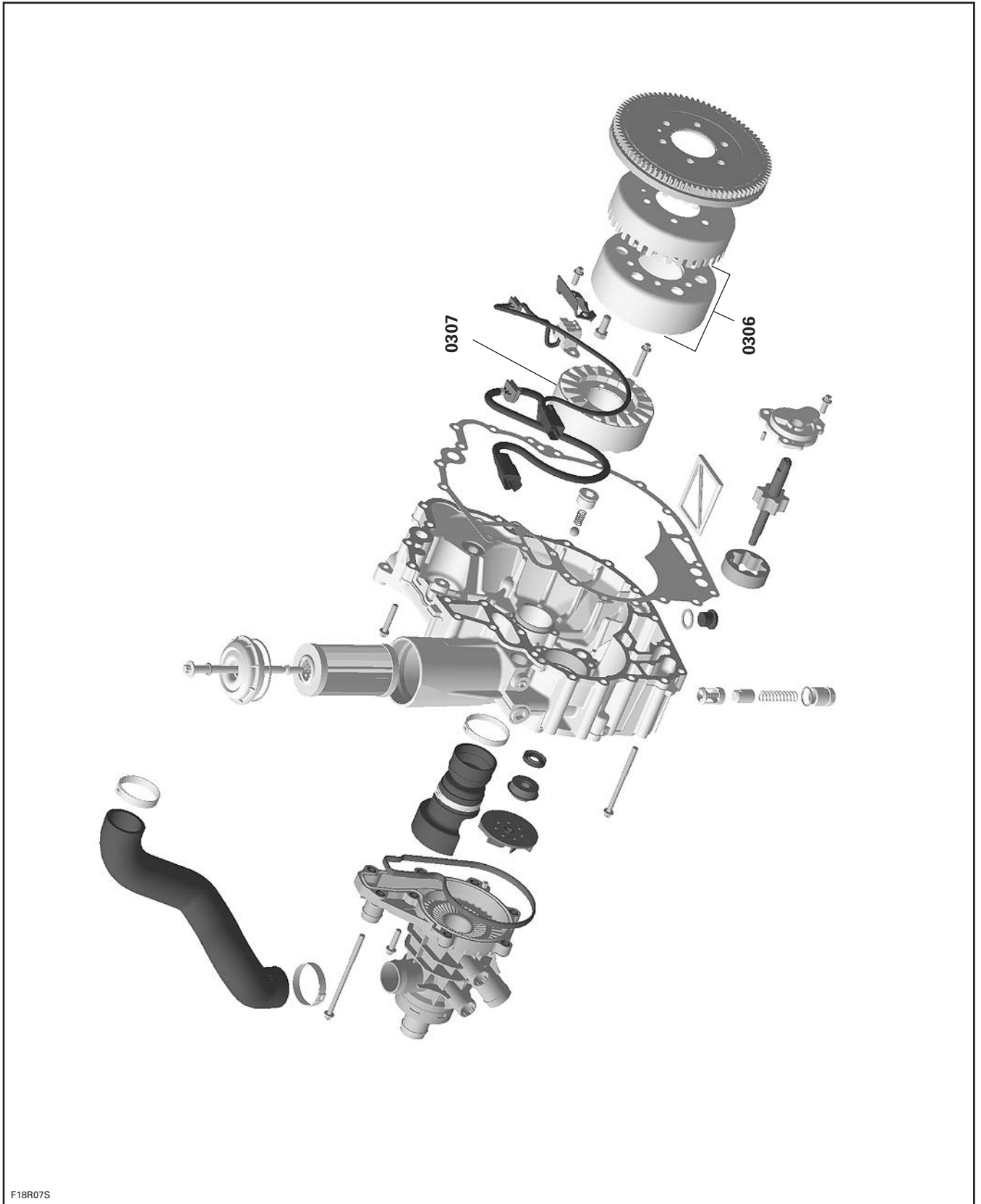

SYSTEM SYSTÈME	CODE	DESCRIPTION	GTI	RXT	RXT X	RXP	RXP IC	RXP X	GTX/ WAKE	GTX/ WAKE IC
			1	2	3	4	5	6	7	8
04	00	NO LABOR INVOLVED AUCUNE MAIN-D'OEUVRE	0	0	0	0	0	0	0	0
04	02	ELECTRIC STARTER (ASS'Y) DÉMARREUR ÉLECTRIQUE (COMPLET)	0.5	0.5	0.5	0.6	0.6	0.6	0.5	0.5
04	03	ONE OR ALL STARTER COMPONENTS UNE OU TOUTE LES PIÈCES DU DÉMARREUR	0.7	0.7	0.7	0.8	0.8	0.8	0.7	0.7
04	05	STARTER RELAY SOLÉNOÏDE DÉMARREUR	0.3	0.3	0.3	0.3	0.3	0.3	0.3	0.3
04	08	STARTER DRIVE (ASS'Y) AND/OR COVER ENTRAÎNEMENT DU DÉMARREUR (COMPLET) ET/OU COUVERCLE	2.4	3.4	3.5	2.7	3.4	3.5	2.4	3.4
04	10	ELECTRIC STARTER DRIVE (ASS'Y) ENTRAÎNEMENT DU DÉMARREUR ÉLECTRIQUE (COMPLET)	2.3	3.3	3.4	2.6	3.3	3.4	2.3	3.3

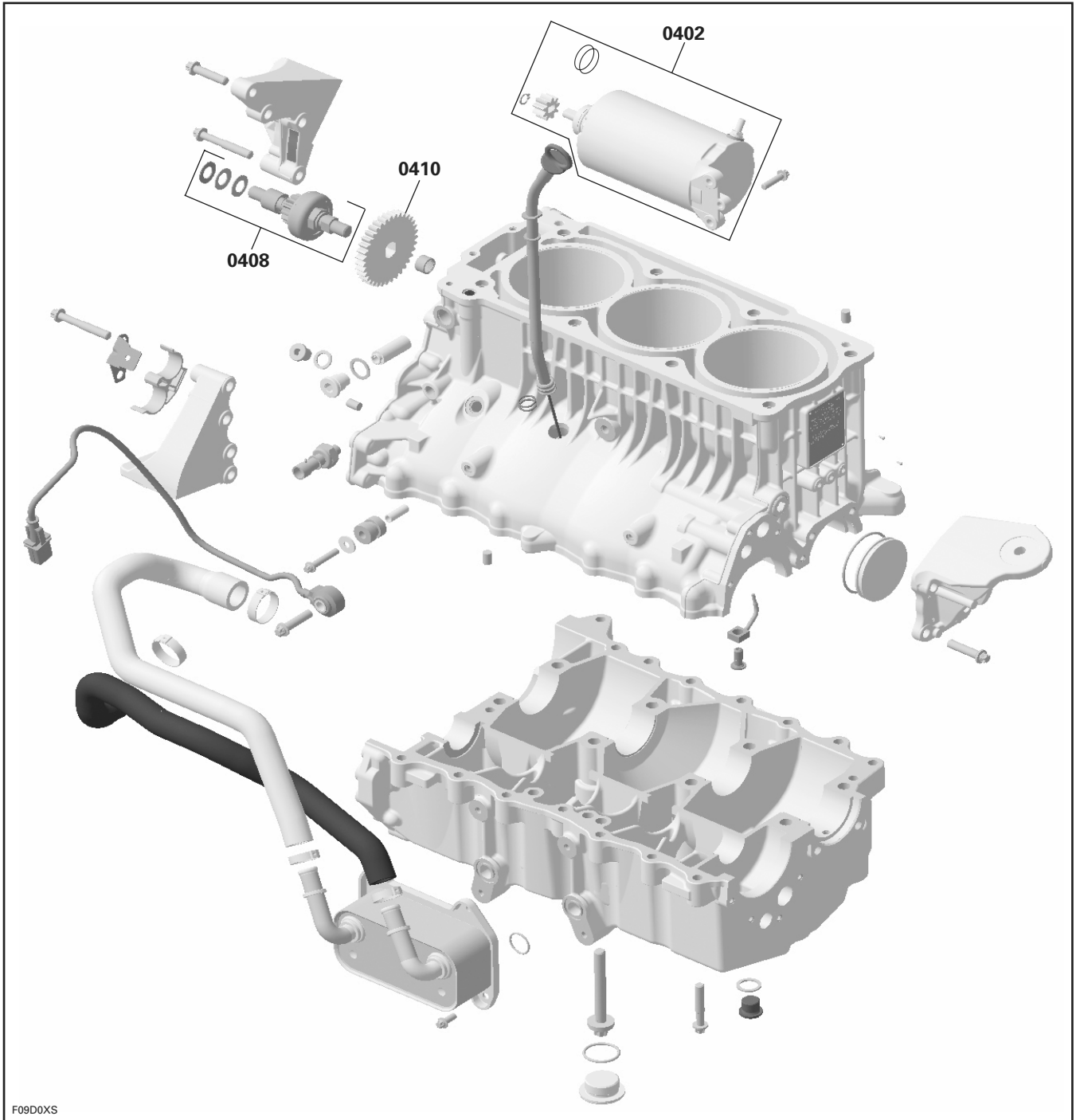

SYSTEM SYSTÈME	CODE	DESCRIPTION	GTI	RXT	RXT X	RXP	RXP IC	RXP X	GTX/ WAKE	GTX/ WAKE IC
			1	2	3	4	5	6	7	8
05	00	NO LABOR INVOLVED AUCUNE MAIN-D'OEUVRE	0	0	0	0	0	0	0	0
05	02	HOSE (FROM SCREEN BAILERS TO IMPELLER HOUSING) BOYAU (TAMIS DÉCLENCHÉMENT AU CARTER D'HÉLICE)	0.4	0.4	0.4	0.4	0.4	0.4	0.4	0.4
05	04	STEERING NOZZLE AND/OR BUSHING AND/OR SLEEVE BUSE DE DIRECTION ET/OU DOUILLE ET/OU MANCHON	0.3	0.3	0.3	0.3	0.3	0.3	0.3	0.3
05	05	VENTURI AND/OR O-RING VENTURI ET/OU JOINT TORIQUE	0.4	0.4	0.4	0.4	0.4	0.4	0.4	0.4
05	06	IMPELLER SHAFT HOUSING COVER AND/OR O-RINGS AND/OR GREASE COUVERCLE ARBRE TURBINE ET/OU JOINT TORIQUE ET/OU GRAISSE	0.5	0.5	0.5	0.5	0.5	0.5	0.5	0.5
05	07	PTO FLYWHEEL RUBBER BOOT CLAMP (EACH) COLLIER DE SERRAGE DU SOUFFLET VOLANT PDM (CHACUN)	0.3	0.3	0.3	0.3	0.3	0.3	0.3	0.3
05	08	PTO FLYWHEEL RUBBER BOOT SOUFFLET CAOUTCHOUC VOLANT CÔTÉ PDM	0.5	1.5	1.6	1.5	1.5	1.6	0.5	1.5
05	11	DRIVE SHAFT AND/OR BUMPER PLUG ARBRE DE TRANSMISSION ET/OU BOUCHON CONTRE CHOC	0.5	1.5	1.6	1.5	1.5	1.6	0.5	1.5
05	12	IMPELLER AND/OR SHAFT AND/OR WASHER AND/OR THRUST BEARING TURBINE ET/OU ARBRE ET/OU RONDELLE ET/OU PALIER BUTÉE	1.1	1.1	1.1	1.1	1.1	1.1	1.1	1.1
05	13	IMPELLER HOUSING (ASS'Y) CARTER D'HÉLICE (COMPLET)	1.1	1.1	1.1	1.1	1.1	1.1	1.1	1.1
05	15	WEAR RING BAGUE D'USURE	1.4	1.4	1.4	1.4	1.4	1.4	1.4	1.4
05	16	HULL STUDS FOR IMPELLER HOUSING (1 OR 2) GOIJONS DE COQUE POUR CARTER D'HÉLICE (1 OU 2)	0.6	0.6	0.6				0.6	0.6
05	17	HULL STUDS FOR IMPELLER SHAFT (3 OR 4) GOIJONS DE COQUE POUR CARTER D'HÉLICE (3 OU 4)	0.8	0.8	0.8				0.8	0.8
05	18	WATER INLET GRATE GRILLE DE POMPE (ADMISSION D'EAU)	0.3	0.3	0.3	0.3	0.3	0.3	0.3	0.3
05	21	IMPELLER HOUSING REMOVAL AND INSTALLATION DÉPOSE ET INSTALLATION DU CARTER D'HÉLICE	0.5	0.5	0.5	0.5	0.5	0.5	0.5	0.5
05	30	REVERSE GATE (ASS'Y) DÉFLECTEUR DE MARCHE ARRIÈRE (COMPLET)	0.3	0.3	0.3	0.3	0.3	0.3	0.3	0.3
05	31	REVERSE CABLE (1) CÂBLE DE MARCHE ARRIÈRE (1)	1.0	1.0	1.0	1.0	1.0	1.0	0.9	1.0
05	37	SPEED SENSOR (ASS'Y) CAPTEUR DE VITESSE (COMPLET)	0.4	0.4	0.4	0.4	0.4	0.4	0.4	0.4
05	38	PUMP SUPPORT SUPPORT DE POMPE	3.2	4.2	4.2	4.2	4.2	4.2	3.2	4.2
05	45	RING CARBONE BAGUE AU CARBONE	0.5	1.5	1.6	1.5	1.5	1.6	0.5	1.5

SYSTEM SYSTÈME	CODE	DESCRIPTION	GTI	RXT	RXT X	RXP	RXP IC	RXP X	GTX/ WAKE	GTX/ WAKE IC
			1	2	3	4	5	6	7	8
05	55	HANDLE REVERSE (ASS'Y) AND/OR INTERIOR LEVER MANETTE DE MARCHE ARRIÈRE (COMPLET) ET/OU LEVIER INTÉRIEUR	0.3	0.3	0.3	0.3	0.3	0.3	0.3	0.3
05	56	REVERSE CABLE SUPPORT SUPPORT DE CÂBLE DE MARCHE ARRIÈRE	0.4	0.4	0.4	0.4	0.4	0.4	0.4	0.4
05	64	ARM BLACK BRAS NOIR	0.4	0.4	0.4	0.4	0.4	0.4	0.4	0.4
05	65	TRIANGLE TRIANGLE	0.3	0.3	0.3	0.3	0.3	0.3	0.3	0.3
05	66	ROD PIVOT PIVOT DE RACCORD	0.3	0.3	0.3	0.3	0.3	0.3	0.3	0.3
05	71	RING SPACER AND/OR PROPELLER SHAFT AND/OR O-RING BAGUE D'ARBRE D'HÉLICE ET/OU ENTRETOISE ET/OU JOINT TORIQUE	0.5	1.5	1.6	1.5	1.5	1.6	0.5	1.5

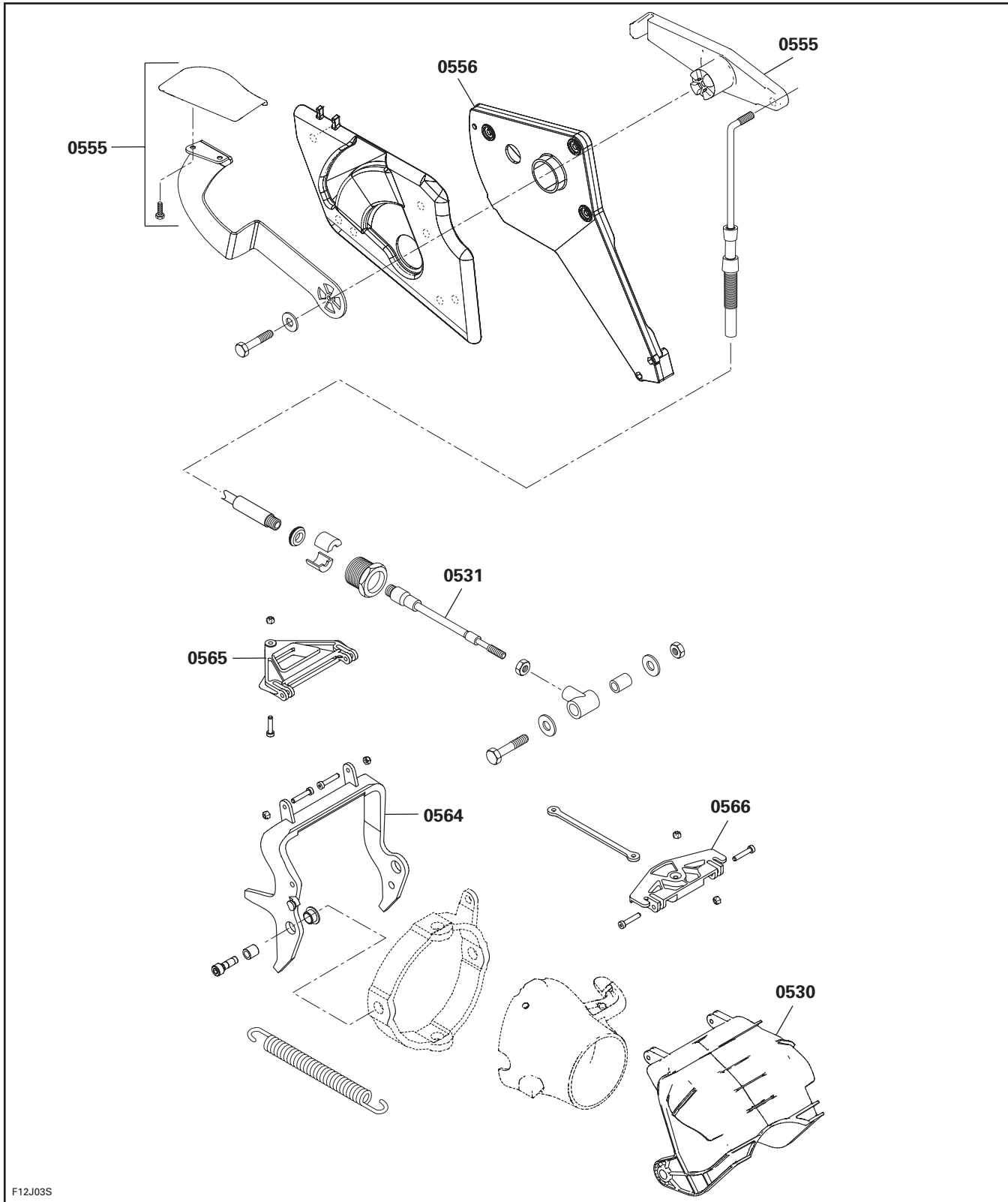

F12J03S

SYSTEM SYSTÈME	CODE	DESCRIPTION	GTI	RXT	RXT X	RXP	RXP IC	RXP X	GTX/ WAKE	GTX/ WAKE IC
			1	2	3	4	5	6	7	8

07	00	NO LABOR INVOLVED AUCUNE MAIN-D'OEUVRE	0	0	0	0	0	0	0	0
07	01	HANDLE GRIP (1 OR 2) GAINE DE GUIDON (1 OU 2)	0.3	0.3	0.3	0.3	0.3	0.3	0.3	0.3
07	03	HANDLE HOUSING (LEFT) LOGEMENT DE GUIDON (GAUCHE)	0.4	0.4	0.4	0.4	0.4	0.4	0.4	0.4
07	04	THROTTLE HANDLE HOUSING (RIGHT) LOGEMENT DE MANETTE D'ACCÉLÉRATEUR (DROIT)	0.3	0.3	0.3	0.3	0.3	0.3	0.3	0.3
07	05	STEERING COVER AND/OR FOAM COUVRE-GUIDON ET/OU MOUSSE	0.4	0.4	0.3	0.4	0.4	0.3	0.4	0.4
07	06	HANDLEBAR GUIDON	0.6	0.5	0.5	0.5	0.5	0.5	0.5	0.5
07	07	STEERING STEM ARM BRAS DE TIGE DE DIRECTION	1.1	1.0	0.4	1.0	1.0	0.4	1.0	1.0
07	08	STEERING STEM TIGE DE DIRECTION	1.2	1.1	0.8	1.1	1.1	0.8	1.1	1.1
07	10	STEERING CABLE SUPPORT SUPPORT DU CÂBLE DE DIRECTION	0.4	0.3	0.3	0.3	0.3	0.3	0.3	0.3
07	11	STEERING COLUMN SUPPORT SUPPORT DE LA COLONNE DE DIRECTION	1.2	1.1	0.8	1.1	1.1	0.8	1.1	1.1
07	13	STEERING CABLE (FROM NOZZLE TO STEM ARM) CÂBLE DE DIRECTION (DU BRAS DE TIGE À LA BUSE)	0.8	0.7	0.7	0.7	0.7	0.7	0.7	0.7
07	14	FRONT BALL JOINT STEERING CABLE JOINT À ROTULE AVANT (CÂBLE DE DIRECTION)	0.3	0.3	0.3	0.3	0.3	0.3	0.3	0.3
07	15	REAR BALL JOINT STEERING CABLE (1 OR 2) JOINT À ROTULE ARRIÈRE (CÂBLE DE DIRECTION) (1 OU 2)	0.3	0.3	0.3	0.3	0.3	0.3	0.3	0.3
07	17	WORM SCREW (VTS) VIS SANS FIN (VTS)			0.7	0.7	0.7	0.7		
07	18	VTS HOUSING BOÎTIER VTS			0.7	0.7	0.7	0.7		
07	22	MOULDING ROD (VTS) TIGE ENROBÉE (VTS)			0.3	0.3	0.3	0.3		
07	23	TRIMMING RING (VTS) BAGUE CORRECTEUR D'ASSIETTE (VTS)			0.3	0.3	0.3	0.3		
07	26	VTS MOTOR (ASS'Y) MOTEUR VTS (COMPLET)			0.5	0.5	0.5	0.5		
07	38	VTS COVER AND/OR GASKET COUVERCLE DU VTS ET/OU JOINT D'ÉTANCHÉITÉ			0.3	0.3	0.3	0.3		
07	40	SLIDING BLOCK (VTS) BLOC COULISSANT (VTS)			0.6	0.6	0.6	0.6		
07	47	PAD HANDLE SUPPORT SUPPORT DU TAMPON DE GUIDON	0.5	0.5		0.5	0.5		0.5	0.5

SYSTEM SYSTÈME	CODE	DESCRIPTION	GTI	RXT	RXT X	RXP	RXP IC	RXP X	GTX/ WAKE	GTX/ WAKE IC
			1	2	3	4	5	6	7	8
07	48	ADJUSTABLE STEERING SUPPORT SUPPORT DE DIRECTION AJUSTABLE								0.6
07	51	VALVE AND/OR HOSE SOUPAPE ET/OU BOYAU		0.8	1.8				0.8	0.8
07	52	STEERING STEM (OPAS) AND/OR LEVER AND/O TUBE (RIGHT OR LEFT) TIGE DE DIRECTION (OPAS) ET/OU LEVIER ET/OU TUBE (DROIT OU GAUCHE)	0.8	0.8	0.8	0.8	0.8		0.8	0.8
07	53	"U" ARM BRAS EN «U»	0.3	0.3	0.3	0.3	0.3	0.3	0.3	0.3
07	54	SIDE VANE AND/OR CYLINDER SUPPORT (ASS'Y) (RIGHT OR LEFT) DÉRIVE LATÉRALE ET/OU SUPPORT DE CYLINDRE (COMPLET) (DROIT OU GAUCHE)	0.3	0.3	0.3	0.3	0.3	0.3	0.3	0.3
07	55	FITTING-ELBOW AND/OR STRAINER-MOLDED RACCORD ET/OU TAMIS MOULÉ		0.3	0.3				0.3	0.3
07	56	OPAS HOSES (2) BOYAUX OPAS (2)	1.2	1.2	1.2	1.2	1.2	1.2	1.2	1.2
07	79	HANDLE BAR EXTENSION EXTENSION DE GUIDON			0.3			0.3		

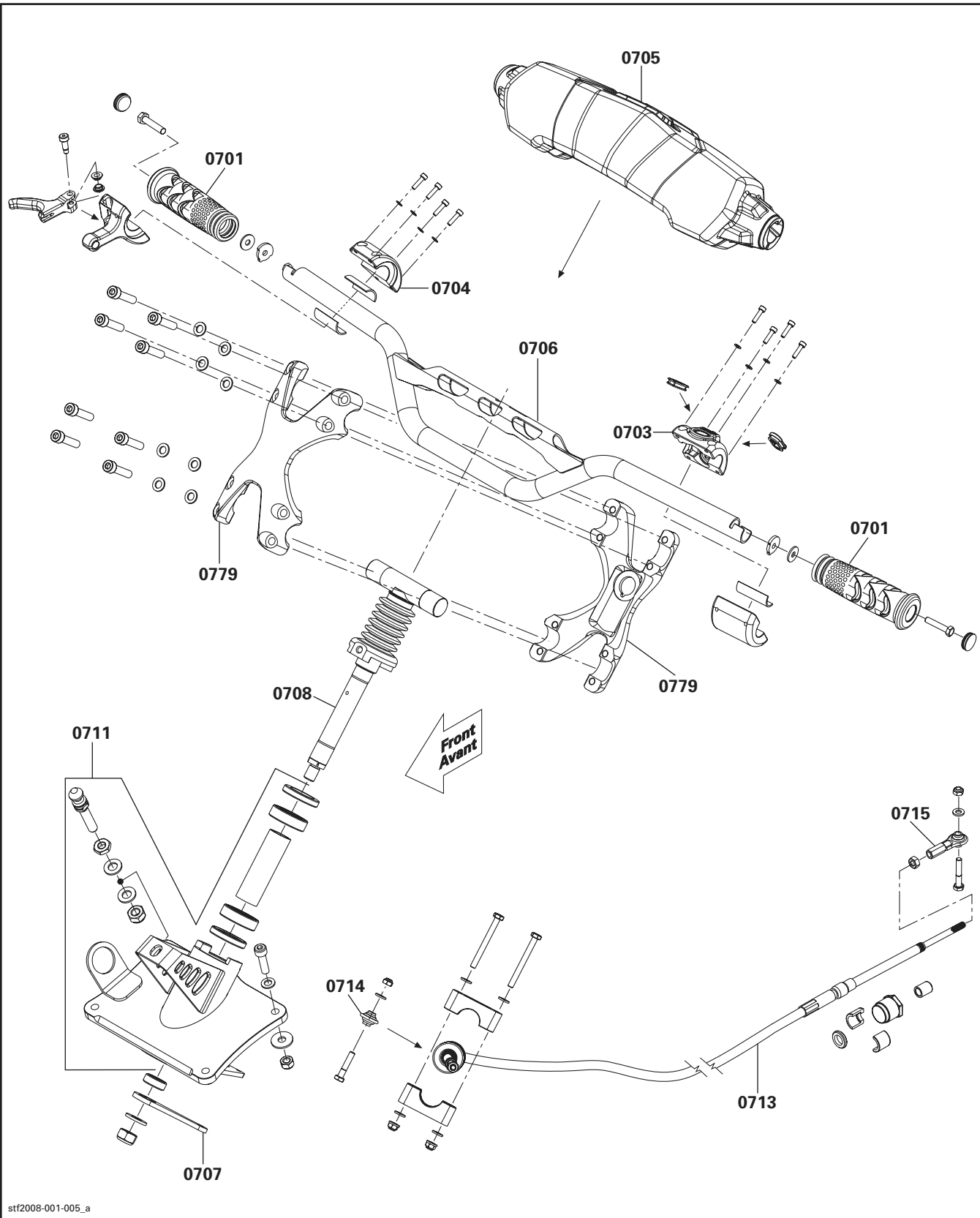

stf2008-001-005_a

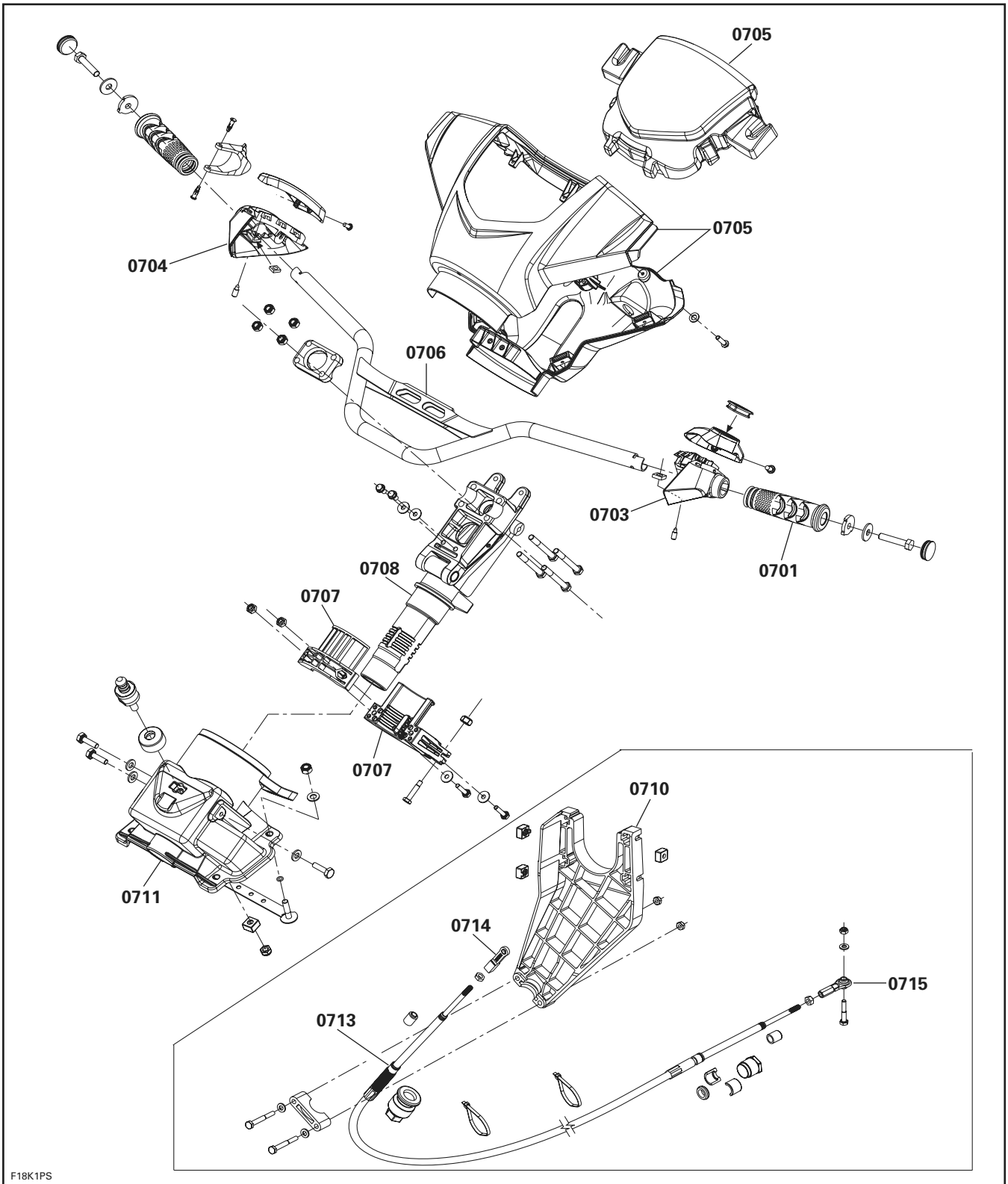

F18K1PS

GTX/RXT

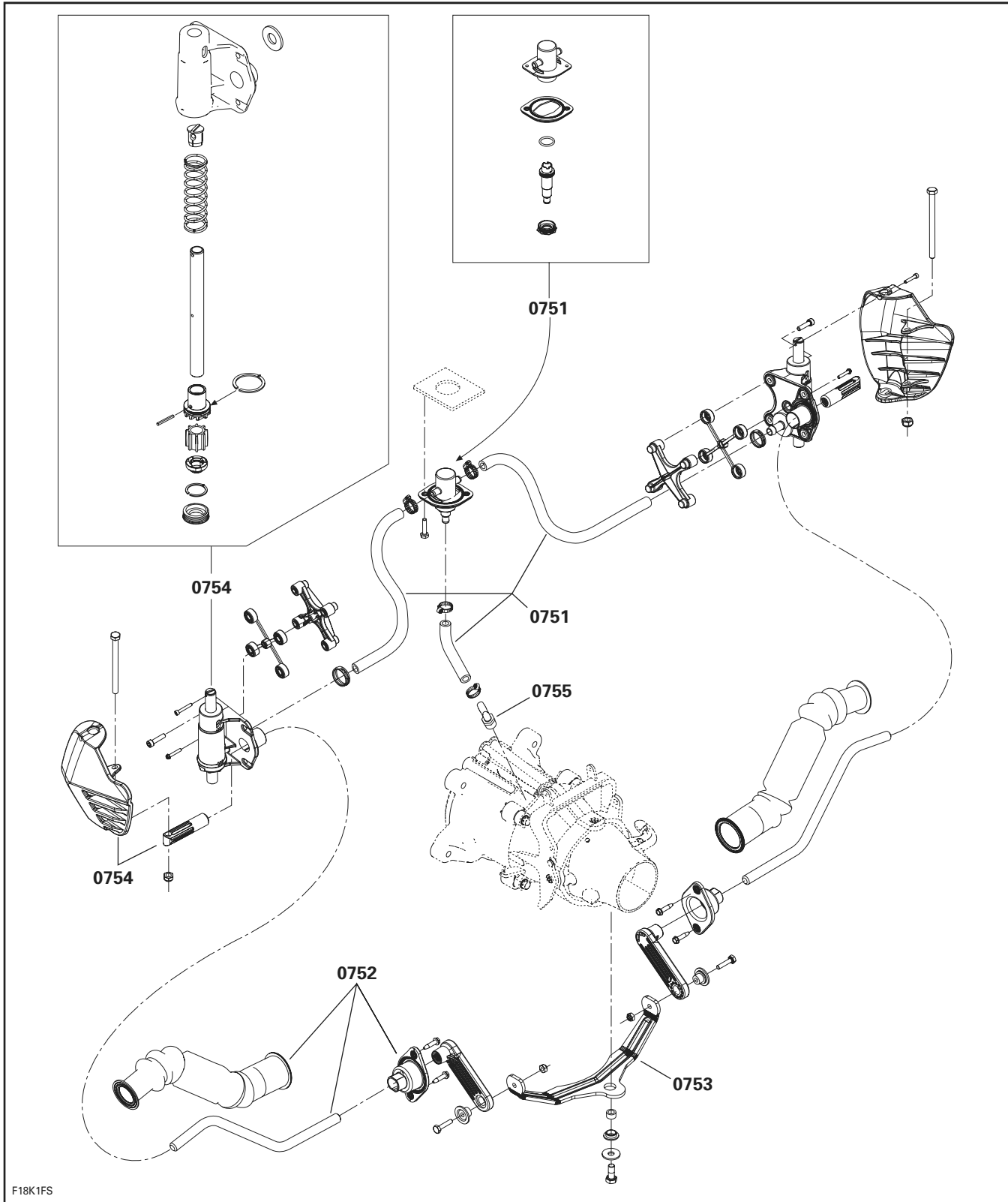

RXP/GTI

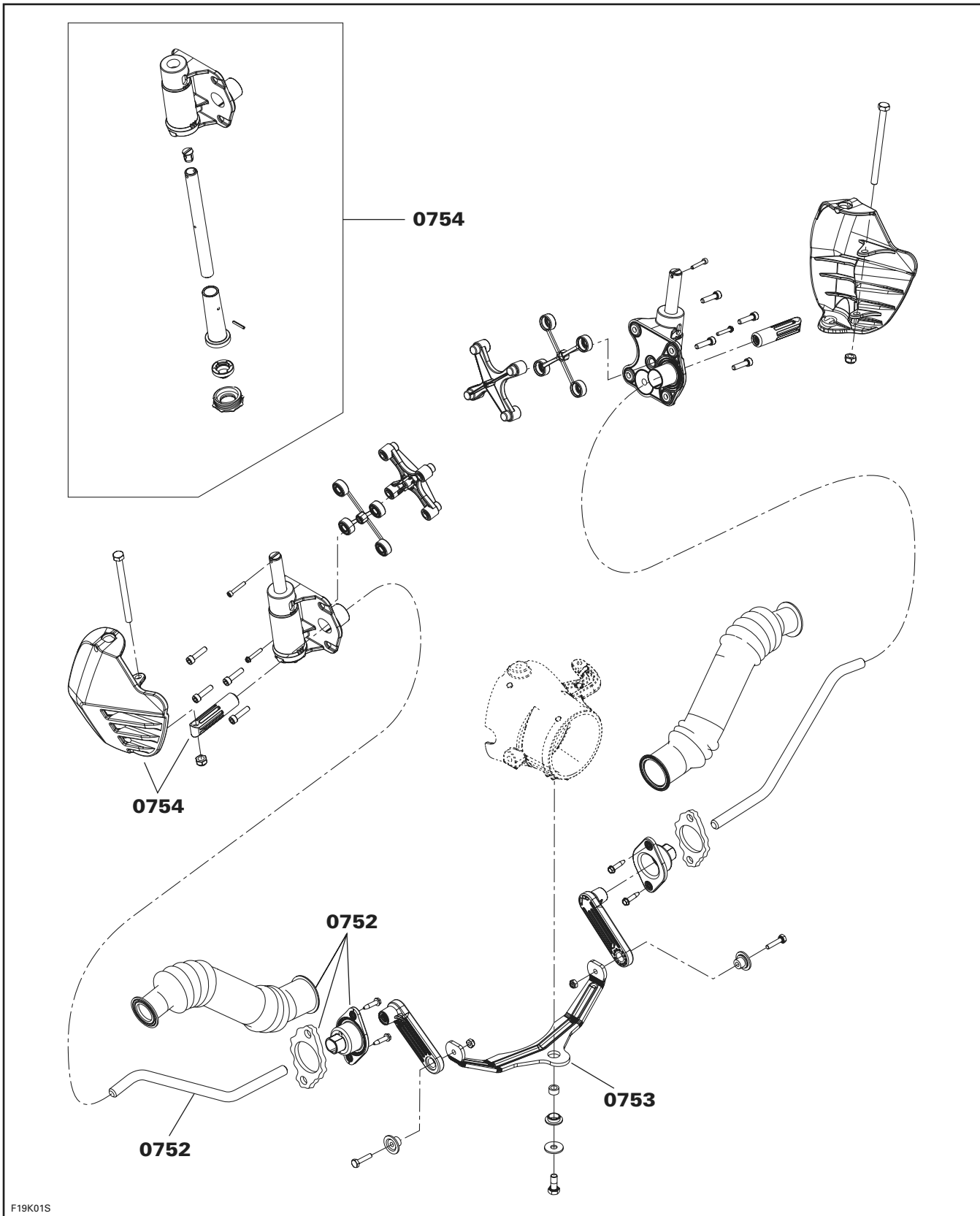

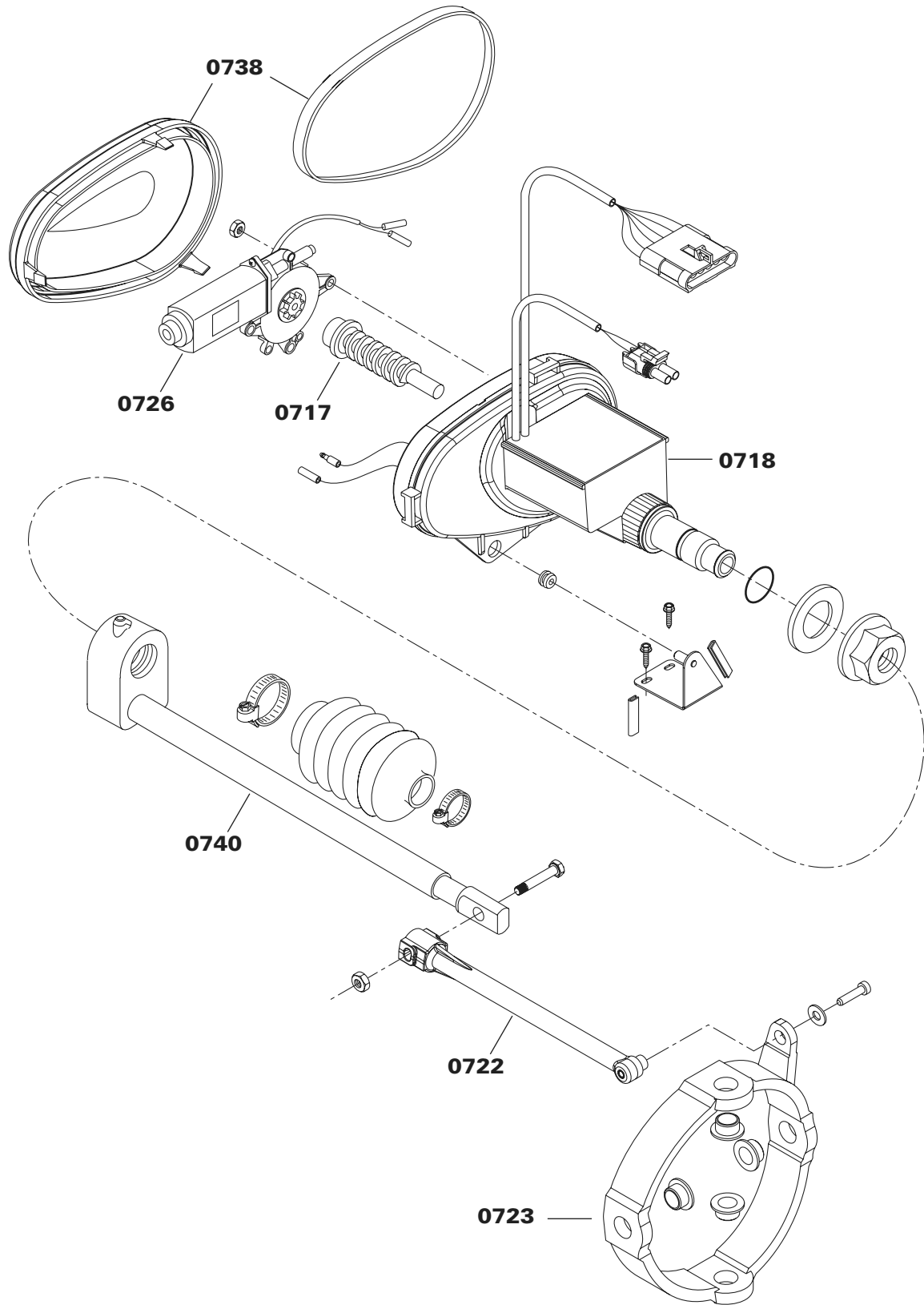

F19K02S

SYSTEM SYSTEME	CODE	DESCRIPTION	GTI	RXT	RXT X	RXP	RXP IC	RXP X	GTX/ WAKE	GTX/ WAKE IC
			1	2	3	4	5	6	7	8
09	00	NO LABOR INVOLVED AUCUNE MAIN-D'OEUVRE	0	0	0	0	0	0	0	0
09	01	FRONT BUMPER PARE-CHOCS AVANT	0.3	0.3	0.3	0.3	0.3	0.3	0.3	0.3
09	02	SIDE BUMPER (LEFT OR RIGHT) (1) PARE-CHOCS LATÉRAL (GAUCHE OU DROIT) (1)	0.9	0.9	0.9	0.9	0.9	0.9	0.9	0.9
09	03	SIDE BUMPER TRIM (LEFT OR RIGHT) (1) MOULURE DE PARE-CHOCS LATÉRALE (GAUCHE OU DROIT) (1)	0.3	0.3	0.3	0.3	0.3	0.3	0.3	0.3
09	04	SIDE BUMPER (BOTH SIDE) (2) PARE-CHOCS LATÉRAL (LES DEUX CÔTÉS) (2)	1.4	1.4	1.4	1.4	1.4	1.4	1.4	1.4
09	05	SIDE BUMPERS TRIMS (BOTH SIDES) (2) MOULURE DE PARE-CHOCS LATÉRAL (LES DEUX CÔTÉS) (2)	0.3	0.3	0.3	0.3	0.3	0.3	0.3	0.3
09	06	REAR BUMPER PARE-CHOCS ARRIÈRE	0.4	0.4	0.4	0.4	0.4	0.4	0.4	0.4
09	07	REAR BUMPER TRIM MOULURE DU PARE-CHOCS ARRIÈRE	0.3	0.3	0.3	0.3	0.3	0.3	0.3	0.3
09	08	CORNER BUMPER (LEFT OR RIGHT) COIN DE PARE-CHOCS (GAUCHE OU DROIT)	0.3	0.3	0.3	0.3	0.3	0.3	0.3	0.3
09	09	"U" CLAMP AND/OR SKI HOOK AND/OR FINITION/RETAINER PLATE BRIDE EN «U» ET/OU CROCHET SKI ET/OU PLAQUE RETENUE	0.4	0.4	0.4	0.4	0.4	0.4	0.4	0.4
09	10	STORAGE COVER (ANY OR ALL PARTS) COUVERCLE À BAGAGES (UNE OU TOUTES LES PIÈCES)	0.5	1.0	1.0	1.7	1.7	1.7	0.7	0.7
09	11	STRAGE COVER HINGE CHARNIÈRE DU COUVERCLE À BAGAGES	0.4	0.4	0.4	0.4	0.4	0.4	0.4	0.4
09	12	STORAGE COVER LATCH LOQUET DU COUVERCLE À BAGAGES	0.3	0.3	0.3	0.3	0.3	0.3	0.3	0.3
09	13	STORAGE COVER NEOPRENE SEAL ANNEAU EN NÉOPRÈNE DU COUVERCLE À BAGAGES	0.3	0.5	0.5	0.5	0.5	0.5	0.5	0.5
09	14	STORAGE COVER DECAL DÉCALQUE DU COUVERCLE À BAGAGES	0.3	0.3	0.3	0.3	0.3	0.3	0.3	0.3
09	15	SIDE BODY DECAL (RIGHT) (1 OR 2) DÉCALQUE LATÉRAL DE LA CARROSSERIE (DROIT) (1 OU 2)	0.6	0.6	0.6	0.6	0.6	0.6	0.6	0.6
09	16	SIDE BODY DECAL (LEFT) (1 OR 2) DÉCALQUE LATÉRAL DE LA CARROSSERIE (GAUCHE) (1 OU 2)	0.6	0.6	0.6	0.6	0.6	0.6	0.6	0.6
09	17	ALL BODY DECALS TOUS LES DÉCALQUES DE LA CARROSSERIE	1.2	1.2	1.2	1.2	1.2	1.2	1.2	1.2
09	19	SIDE CARPET (1) TAPIS LATÉRAL (1)	0.3	0.3	0.3	0.3	0.3	0.3	0.3	0.3
09	20	SIDE CARPET (2) TAPIS LATÉRAL (2)	0.5	0.5	0.5	0.5	0.5	0.5	0.5	0.5
09	21	REAR CARPET TAPIS ARRIÈRE	0.3	0.3	0.3	0.3	0.3	0.3	0.3	0.3

SYSTEM SYSTÈME	CODE	DESCRIPTION	GTI	RXT	RXT X	RXP	RXP IC	RXP X	GTX/ WAKE	GTX/ WAKE IC
			1	2	3	4	5	6	7	8
09	22	FRONT SEAT (ASS'Y) SIÈGE AVANT (COMPLET)	0.3	0.3	0.3	0.3	0.3	0.3	0.3	0.3
09	24	SEAT BASE AND/OR SEAT COVER BASE DU SIÈGE ET/OU HOUSSE DE SIÈGE				1.8	1.8	1.8		
09	26	SEAT BASE NEOPRENE SEAL ANNEAU EN NÉOPRÈNE DE LA BASE DU SIÈGE	0.3	0.3	0.3	0.3	0.3	0.3	0.3	0.3
09	27	UPPER AND LOWER BRIDGE AND OR SEAL PONT SUPÉRIEUR ET INFÉRIEUR ET/OU ANNEAU		0.3	0.3				0.3	0.3
09	28	SEAT LACHT (ANY OR ALL PARTS) LOQUET DE SIÈGE (UNE OU TOUTE LES PIÈCES)		0.3	0.3	0.3	0.3	0.3	0.3	0.3
09	29	SEAT LACHT HOOK/ KEEPER BASE CROCHET DU LOQUET DU SIÈGE/RETENEUR DE BASE	0.3	0.3	0.3	0.3	0.3	0.3	0.3	0.3
09	30	LACHT STUD (STORAGE COVER OR SEAT) ERGOT D'ENCRAGE (COUVERCLE À BAGAGES OU SIÈGE)		0.3	0.3	0.3	0.3	0.3	0.3	0.3
09	31	FRONT VENT TUBE BOYAU DE VENTILATION AVANT	0.3	0.3	0.3	0.3	0.3	0.3	0.3	0.3
09	32	REAR VENT TUBE BOYAU DE VENTILATION ARRIÈRE	0.3	0.3	0.3	0.3	0.3	0.3	0.3	0.3
09	35	BOX GLOVES AND/OR DOOR BOX COFFRE À GANTS ET/OU PORTE	0.3	0.3	0.3	0.3	0.3	0.3	0.3	0.3
09	37	GRAB HANDLE POIGNÉE DE MAINTIEN	0.4	0.4	0.4	0.4	0.4	0.4	0.4	0.4
09	38	SPONSON (RIGHT OR LEFT) (EACH) STABILISATEUR (DROIT OU GAUCHE) (CHACUN)	0.3	0.3	0.3	0.3	0.3	0.3	0.3	0.3
09	39	MIRROR (1) RÉTROVISEUR (1)	0.6	0.9	0.9	0.3	0.3	0.3	0.9	0.9
09	40	MIRRORS (2) RÉTROVISEURS (2)	0.6	0.9	0.9	0.4	0.4	0.4	0.9	0.9
09	44	SIDE HULL DECAL (1) DÉCALQUE LATÉRAL DE LA COQUE (1)	0.4	0.4	0.4	0.4	0.4	0.4	0.4	0.4
09	45	SIDE HULL DECALS (RIGHT) (2) DÉCALQUES LATÉRAUX DE LA COQUE (2)	0.6	0.6	0.6	0.6	0.6	0.6	0.6	0.6
09	46	SIDE MOULDING (RIGHT OR LEFT) ENJOLIVEUR LATÉRAL (DROIT OU GAUCHE)		0.4	0.4	0.3	0.3	0.3		
09	50	REAR SIDE BODY DECAL DÉCALQUE ARRIÈRE DE LA CARROSSERIE	0.3	0.3	0.3	0.3	0.3	0.3	0.3	0.3
09	51	BRP DECAL(S) DÉCALQUE(S) BRP	0.3	0.3	0.3	0.3	0.3	0.3	0.3	0.3
09	56	SIDE GRILL (RIGHT OR LEFT) GRILLE LATÉRALE (DROIT OU GAUCHE)		0.3	0.3	0.3	0.3	0.3		
09	57	REAR SEAT (ASS'Y) SIÈGE ARRIÈRE (COMPLET)		0.3	0.3				0.3	0.3

SYSTEM SYSTÈME	CODE	DESCRIPTION	GTI	RXT	RXT X	RXP	RXP IC	RXP X	GTX/ WAKE	GTX/ WAKE IC
			1	2	3	4	5	6	7	8
09	77	DEFLECTOR DÉFLECTEUR	0.3	0.7	0.7	0.7	0.7	0.7	0.7	0.7
09	78	STORAGE TRAY COFFRE À BAGAGES	0.3	0.3	0.3	0.3	0.3	0.3		
09	88	LOWER STORAGE COVER (ANY OR ALL PARTS) COUVRE BAGAGES INFÉRIEUR (UNE OU TOUTES LES PIÈCES)		0.7	0.7	1.0	1.0	1.1	0.7	0.7
09	152	SIDE CARPETS (3) TAPIS LATÉRAUX (3)	0.7	0.7	0.7	0.7	0.7	0.7	0.7	0.7
09	153	FRONT COLLECTOR AND/OR GASKET COLLECTEUR AVANT ET/OU JOINT D'ÉTANCHÉITÉ		0.4	0.4	0.4	0.4	0.4	0.4	0.4
09	164	SUPERIOR ENGINE COVER AND/OR SEAL COUVRE MOTEUR SUPÉRIEUR ET/OU ANNEAU D'ÉTANCHÉITÉ				0.5	0.5	0.5		
09	165	INFERIOR ENGINE COVER COUVRE MOTEUR INFÉRIEUR				0.5	0.5	0.5		
09	166	SUPERIOR MOULDING (RIGHT OR LEFT) ENJOLIVEUR SUPÉRIEUR (DROIT OU GAUCHE)		0.4	0.4	0.4	0.4	0.4		
09	167	KNEE PAD (RIGHT OR LEFT) TAMPON GENOU (DROIT OU GAUCHE)				0.3	0.3	0.3		
09	168	FRONT GRILL GRILLE FRONTALE		1.0	1.0	1.1	1.1	1.1		
09	204	SIDE CARPETS (4) TAPIS LATÉRAUX (4)	0.9	0.9	0.9	0.9	0.9	0.9	0.9	0.9
09	205	SIDE CARPETS (5) TAPIS LATÉRAUX (5)	1.1	1.1	1.1	1.1	1.1	1.1	1.1	1.1
09	206	SIDE CARPETS (6) TAPIS LATÉRAUX (6)	1.3	1.3	1.3	1.3	1.3	1.3	1.3	1.3
09	207	SIDE CARPETS (ALL) TAPIS LATÉRAUX (TOUS)	1.5	1.5	1.5	1.5	1.5	1.5	1.5	1.5

RXP

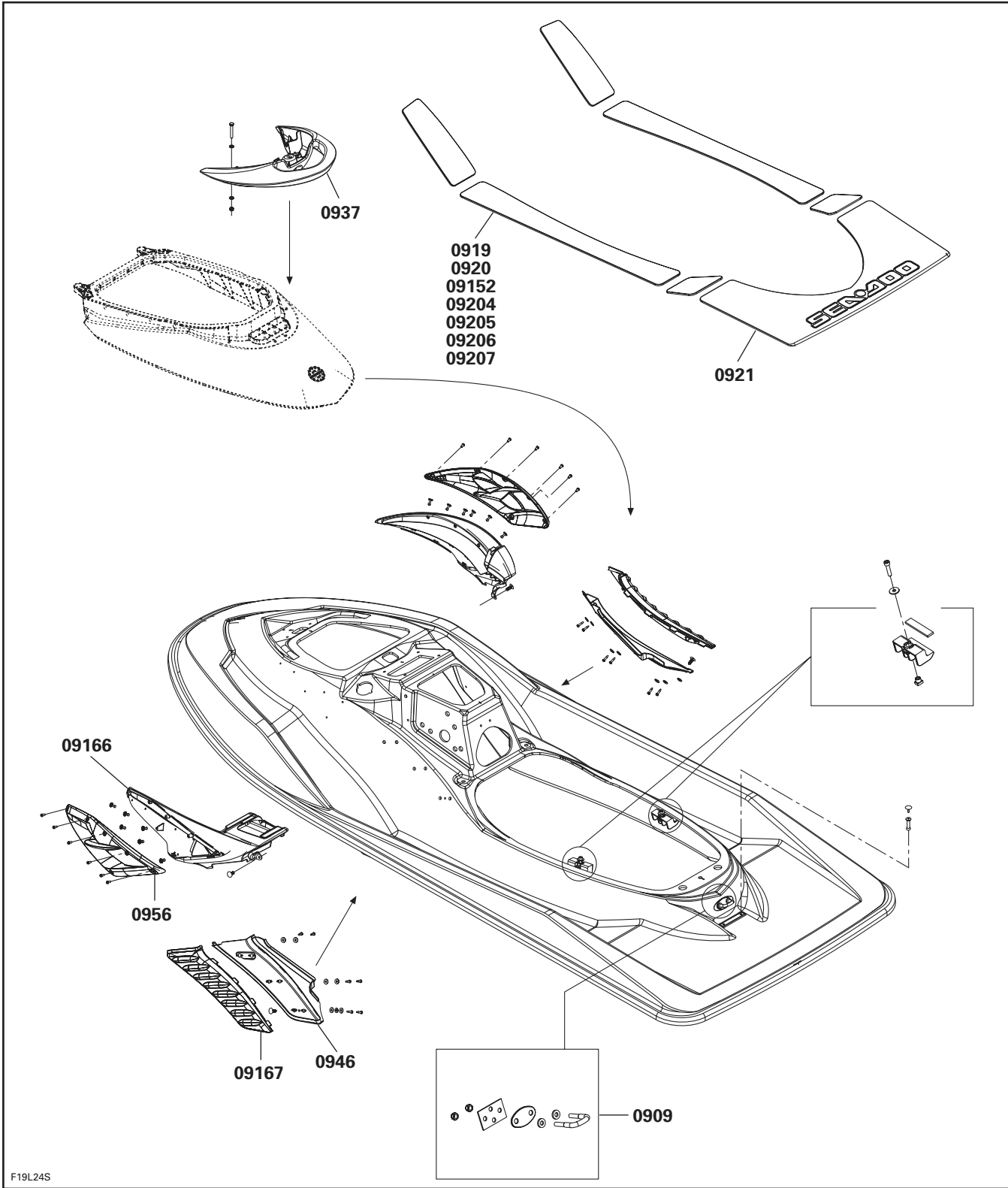

F19L24S

RXP

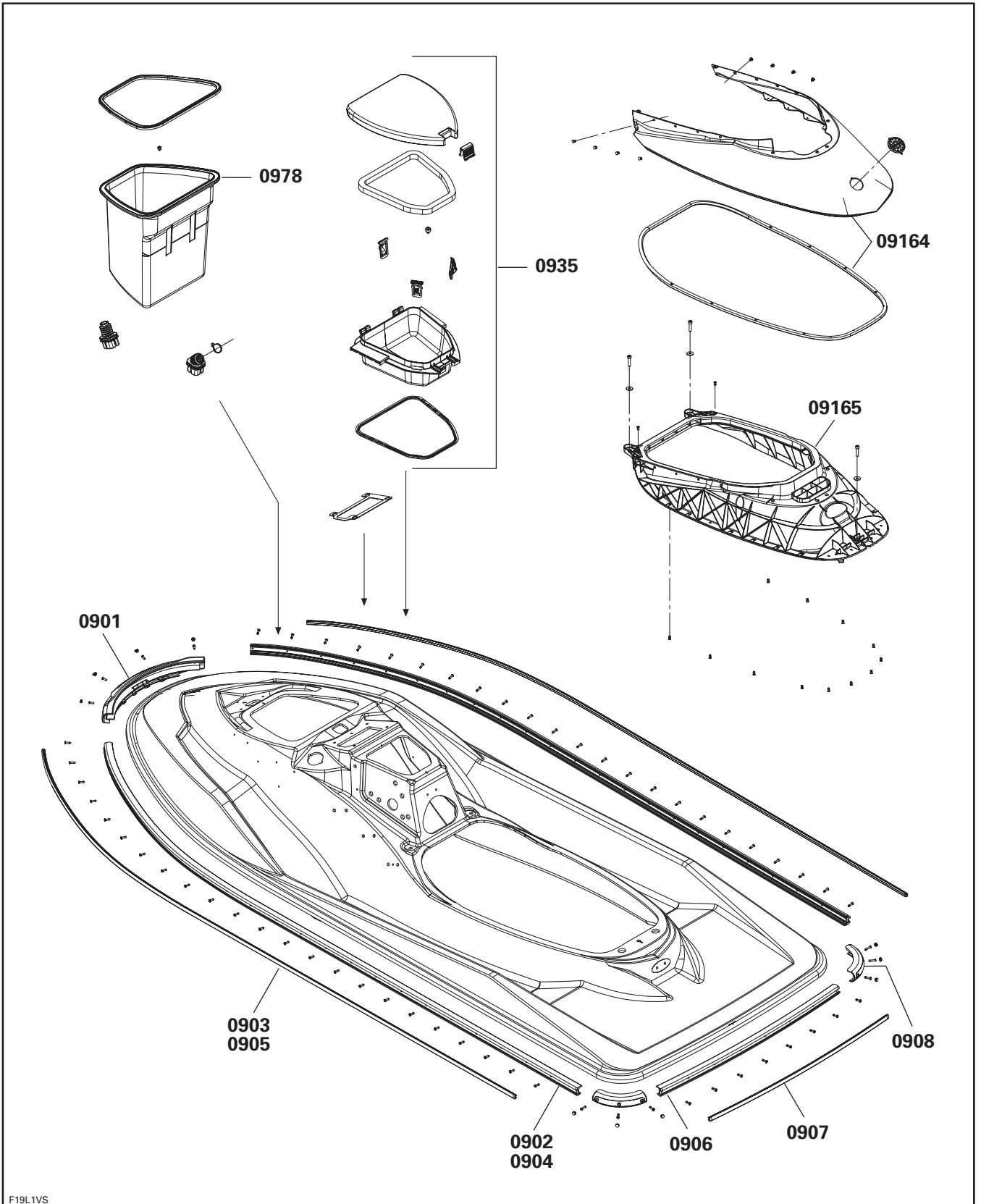

F19L1VS

RXP

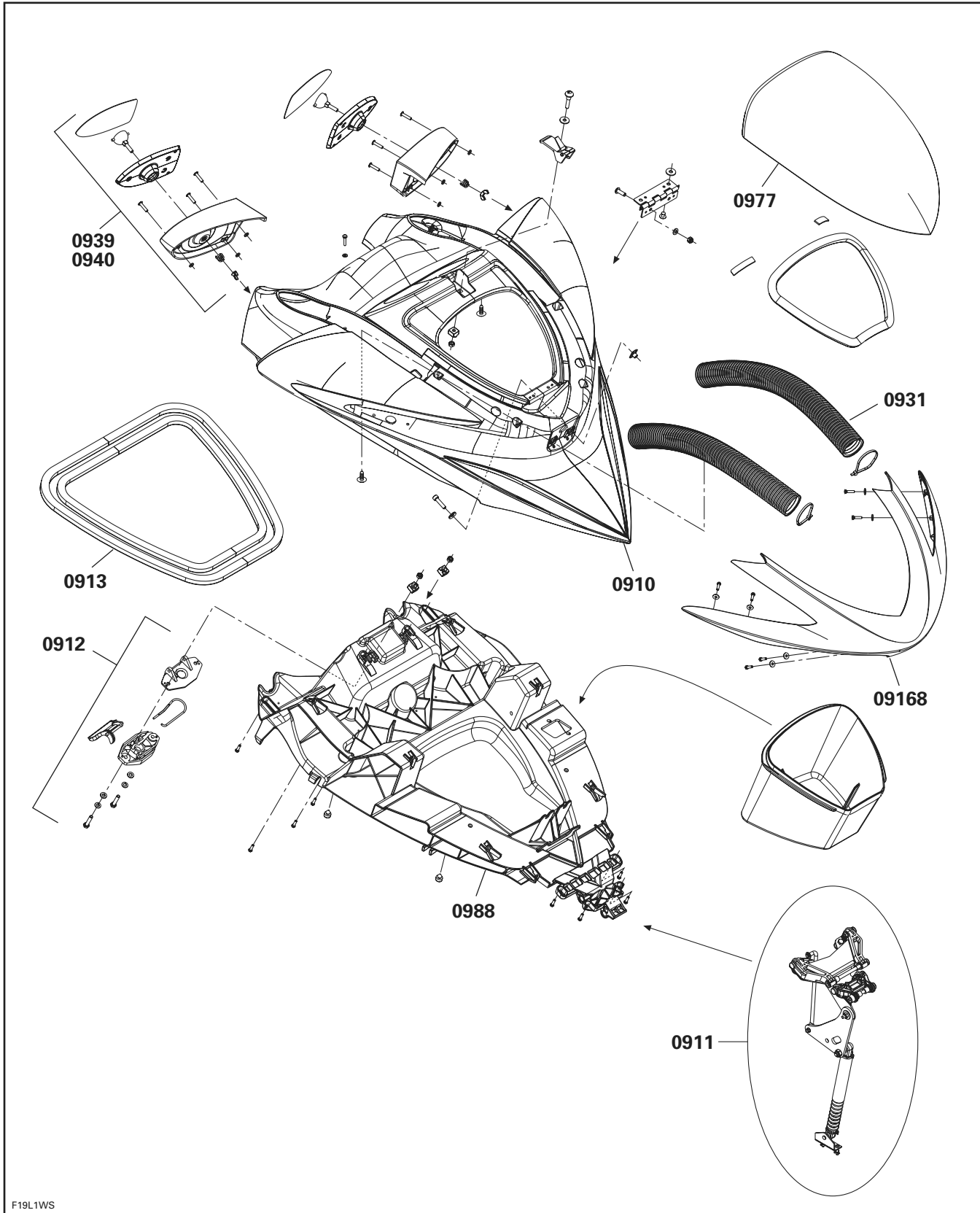

F19L1WS

GTI

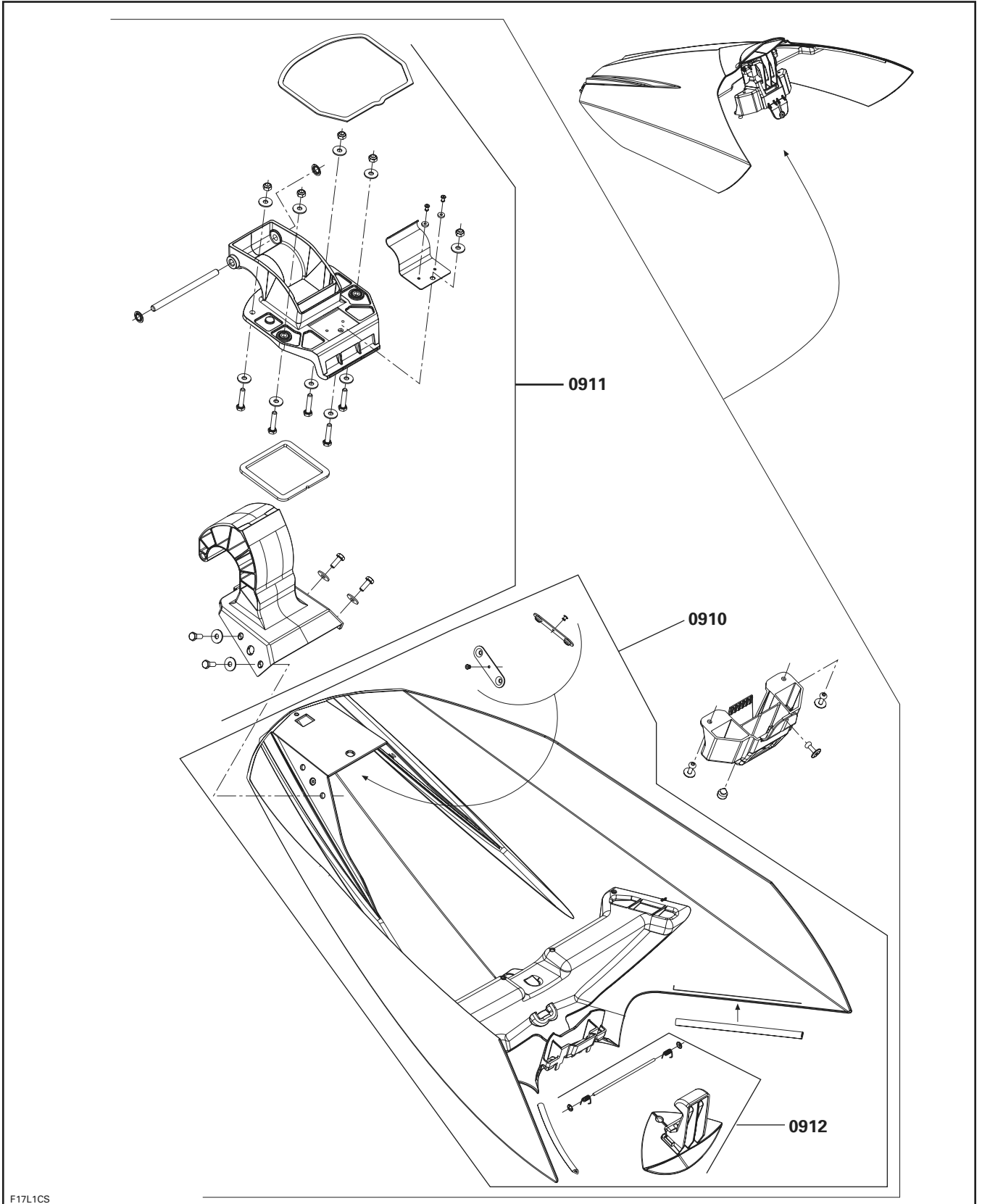

F17L1CS

GTX/WAKE

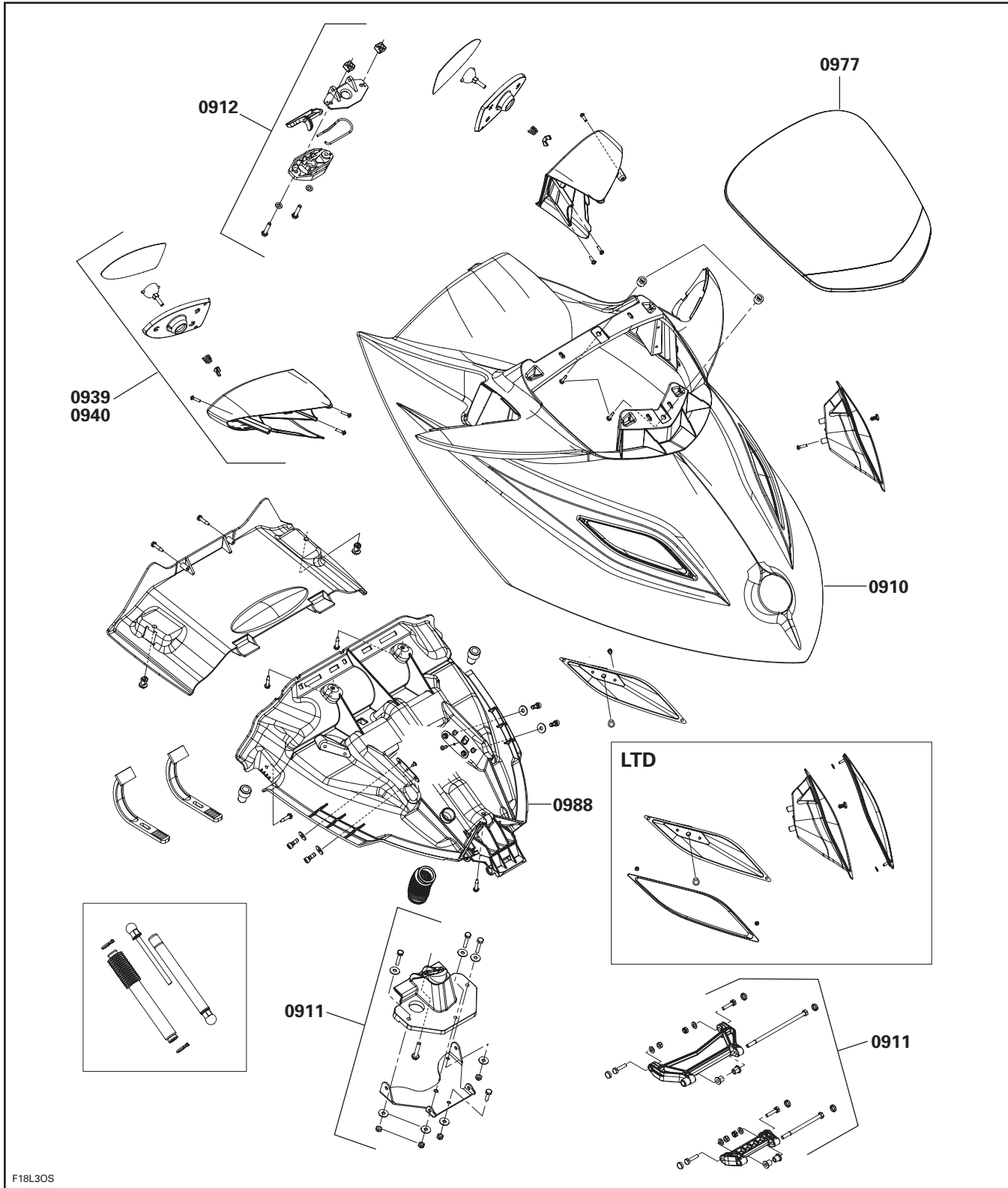

GTX/WAKE/RXT

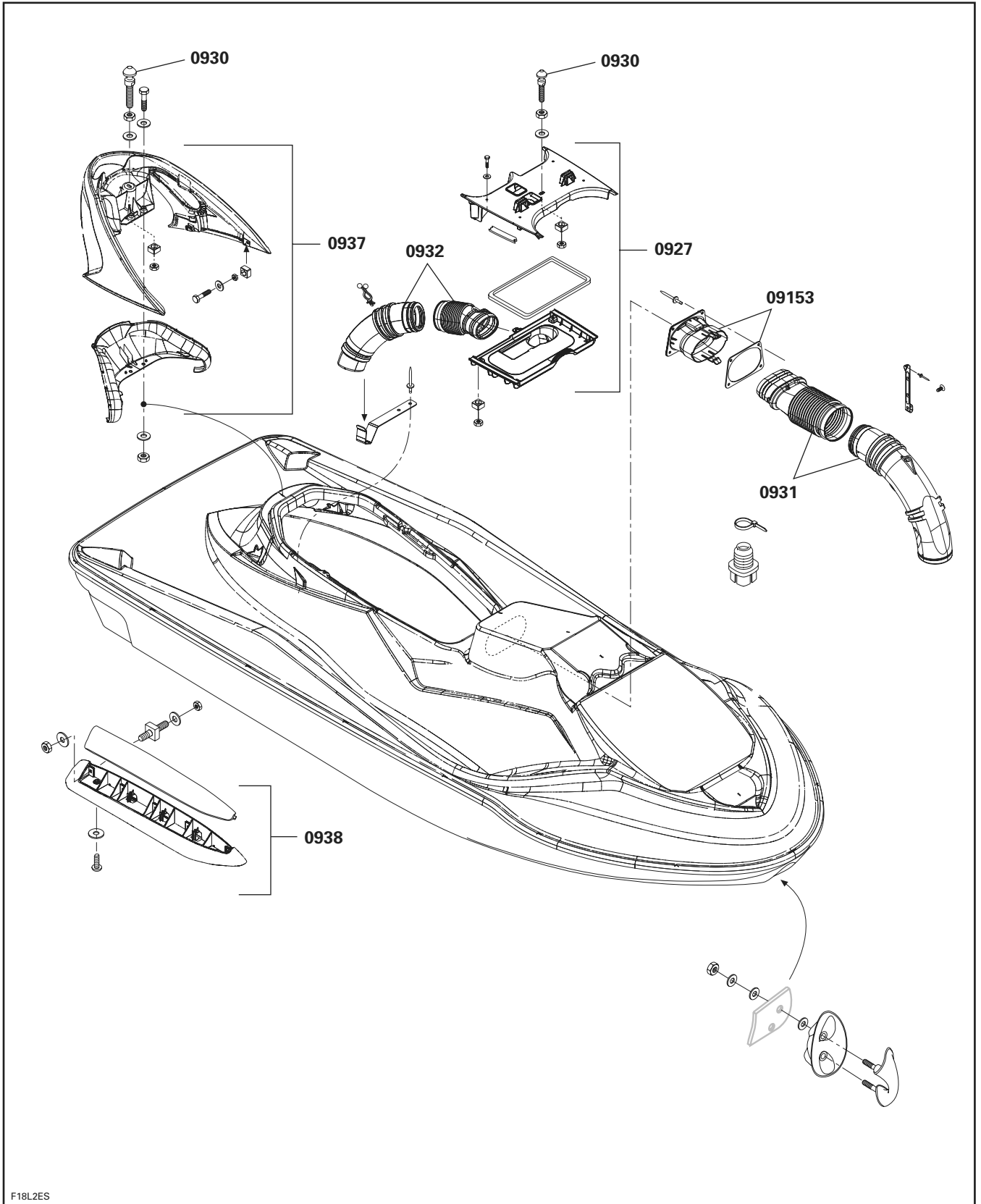

GTX/WAKE/RXT

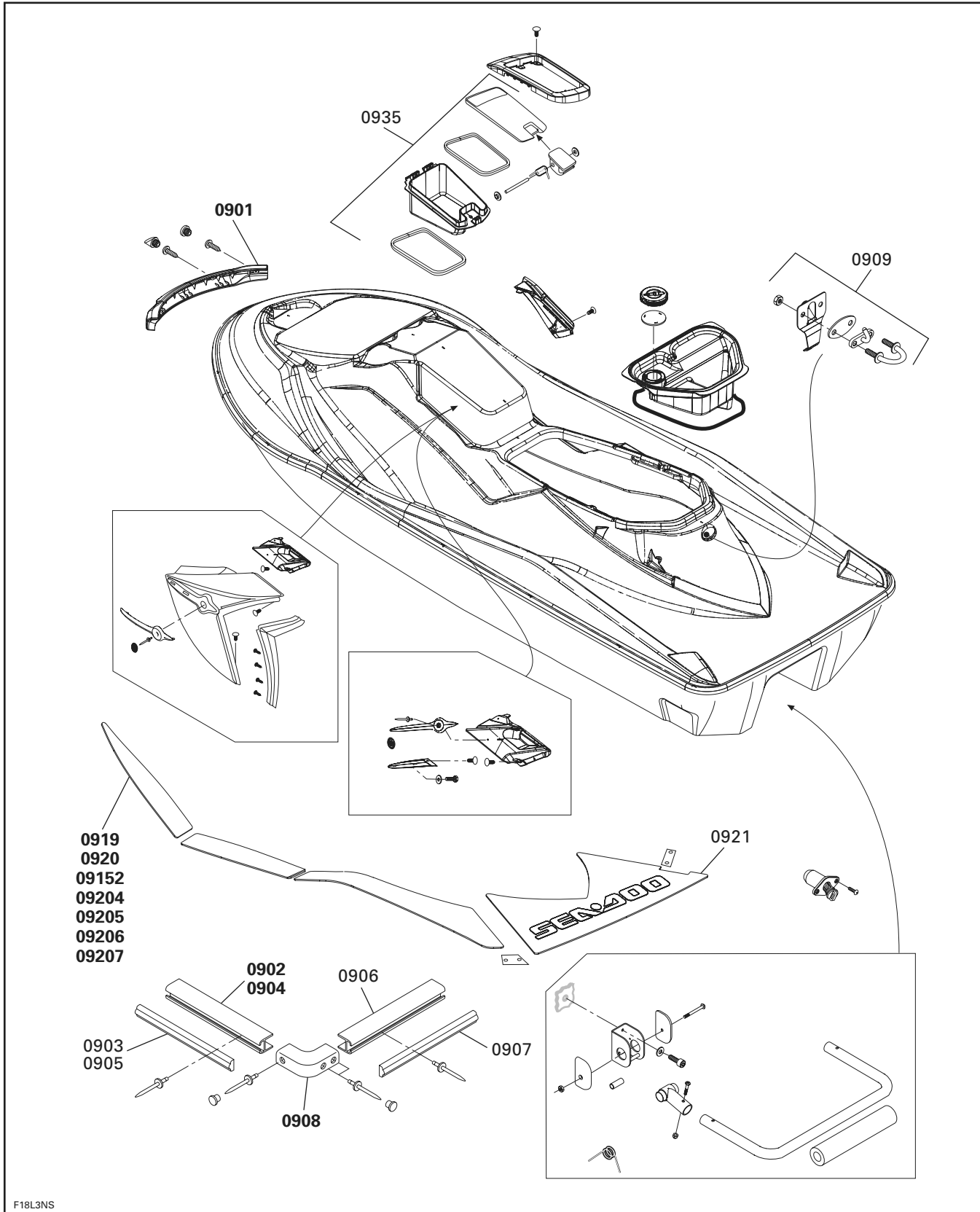

SYSTEM SYSTÈME	CODE	DESCRIPTION	GTI	RXT	RXT X	RXP	RXP IC	RXP X	GTX/ WAKE	GTX/ WAKE IC
			1	2	3	4	5	6	7	8
10	00	NO LABOR INVOLVED AUCUNE MAIN-D'OEUVRE	0	0	0	0	0	0	0	0
10	03	BATTERY BATTERIE	0.3	0.3	0.3	0.3	0.3	0.3	0.3	0.3
10	04	GROUND CABLE CÂBLE DE MASSE	0.3	0.3	0.3	0.3	0.3	0.3	0.3	0.3
10	05	BATTERY RED CABLE (BATTERY TO STARTER RELAY) CÂBLE ROUGE DE BATTERIE (BATTERIE AU SOLÉNOÏDE)	0.3	0.4	0.4	0.3	0.3	0.3	0.4	0.4
10	06	BATTERY RED CABLE (STARTER TO STARTER RELAY) CÂBLE ROUGE DE BATTERIE (DÉMARREUR AU SOLÉNOÏDE)	0.8	0.8	0.8	0.5	0.5	0.5	0.8	0.8
10	09	IGNITION SWITCH (ASS'Y) (STOP/START) INTERRUPTEUR D'ALLUMAGE (COMPLET) (ARRÊT/MARCHE)	0.7	0.7	0.7	0.7	0.7	0.7	0.7	0.7
10	10	ENGINE OVERHEATING BUZZER (ASS'Y) AVERTISSEUR (COMPLET) DE SURCHAUFFE DU MOTEUR	0.7	0.7	0.3	0.7	0.7	0.3	0.7	0.7
10	11	REGULATOR (ASS'Y)/RECTIFIER (ASS'Y) RÉGULATEUR (COMPLET)/REDRESSEUR (COMPLET)	0.3	0.3	0.3	0.3	0.3	0.3	0.3	0.3
10	12	MAIN HARNESS (ASS'Y) CÂBLAGE PRINCIPAL (COMPLET)	2.1	2.2	2.2	2.0	2.0	2.0	2.1	2.2
10	15	BATTERY SUPPORT SUPPORT DE BATTERIE				0.5	0.5	0.5		
10	46	L.C.D INFO GAUGE (MULTIFUNCTION GAUGE) CADRAN INFO MULTIFONCTION	0.3	0.7	0.7	0.3	0.3	0.3	0.7	0.7
10	56	ELECTRONIC CONTROL UNIT UNITÉ CONTRÔLE ÉLECTRONIQUE	0.4	0.4	0.4	0.4	0.4	0.4	0.4	0.4
10	58	BOUSSOLE BOUSSOLE							0.7	0.7
10	59	DEPTH SENDER PROFONDIMÈTRE								0.8
10	61	ENGINE HARNESS (ASS'Y) CÂBLAGE MOTEUR (COMPLET)	1.0	1.0	1.0	1.0	1.0	1.0	1.0	1.0
10	62	STEERING HARNESS (ASS'Y) CÂBLAGE GUIDON (COMPLET)	0.7	0.7	0.7	0.7	0.7	0.7	0.7	0.7
10	65	DESS POST BORNE DESS	0.7	0.7	0.7	0.7	0.7	0.7	0.7	0.7

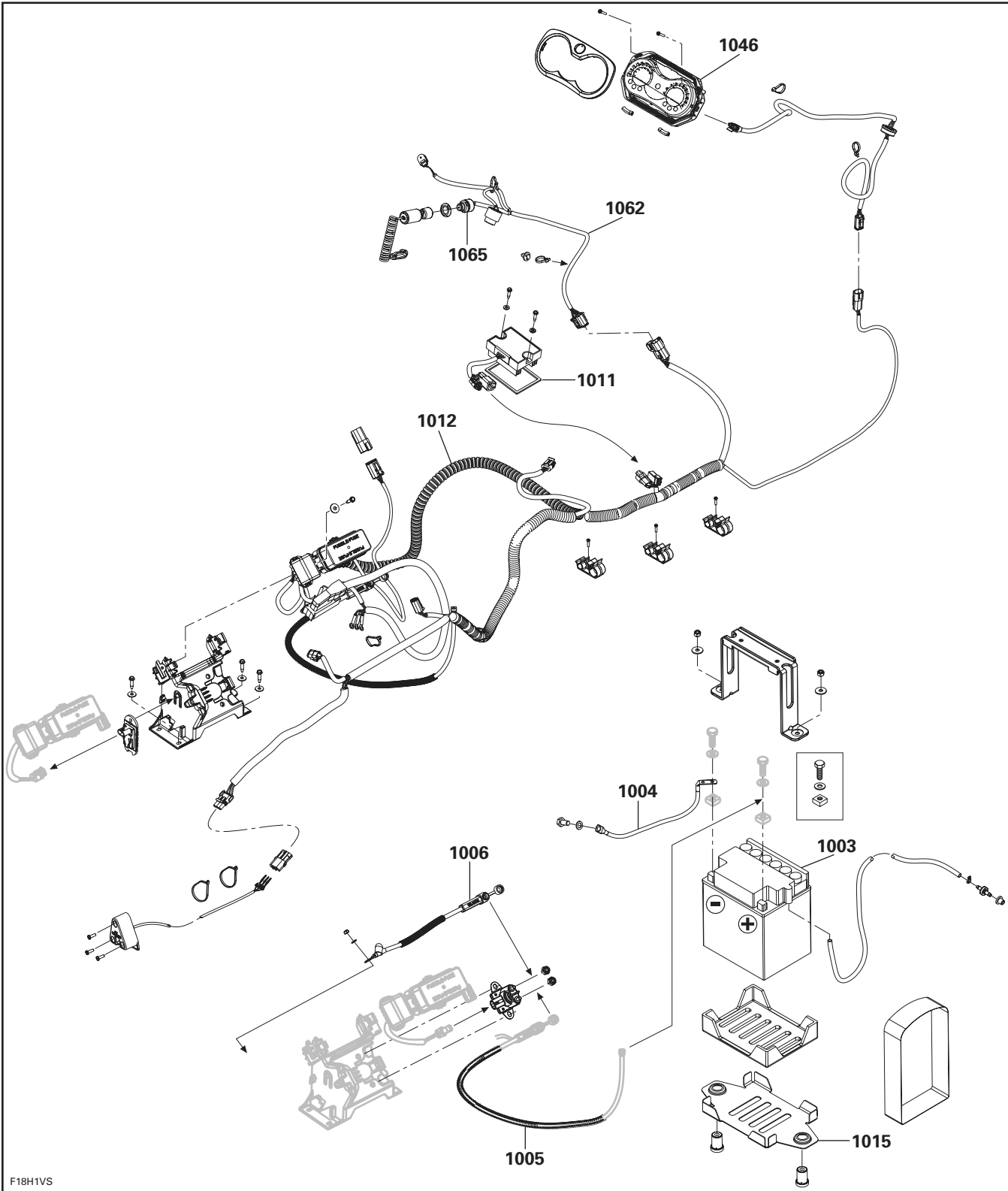

F18H1VS

SYSTEM SYSTÈME	CODE	DESCRIPTION	GTI	RXT	RXT X	RXP	RXP IC	RXP X	GTX/ WAKE	GTX/ WAKE IC
			1	2	3	4	5	6	7	8
11	00	NO LABOR INVOLVED AUCUNE MAIN-D'OEUVRE	0	0	0	0	0	0	0	0
11	MT1	SCHEDULED MAINTENANCE TRACKING SUIVI DES ENTRETIENS PLANIFIÉS	0	0	0	0	0	0	0	0

FLAT RATE TIME SUGGESTION

DEALER'S NO.: _____ DATE: _____

DEALER'S NAME: _____

FILE IDENTIFICATION NO.: _____

ADDRESS: _____

YEAR	MODEL DESCRIPTION	OPERATION	JOB CODE	PRESENT FLAT RATE	SUGGESTED FLAT RATE

Detailed procedure used:

Signature: _____

BOMBARDIER
RECREATIONAL PRODUCTS
WARRANTY DEPARTMENT
75, J.A. BOMBARDIER ST.
SHERBROOKE (QUEBEC)
CANADA, J1L 1W3

FAX NUMBER: 819-566-3590

**BARÈME DE TEMPS À TAUX FIXE
SUGGESTION**

N° DU CONCESSIONNAIRE: _____ DATE: _____

NOM DU CONCESSIONNAIRE: _____

N° D'IDENTIFICATION DU DOSSIER: _____

ADRESSE: _____

ANNÉE	DESCRIPTION DU MODÈLE	OPÉRATION	CODE DE TRAVAUX	TTP ACTUEL	TTP SUGGÉRÉ

Détails de la marche à suivre:

Signature: _____

BOMBARDIER
PRODUITS RÉCRÉATIFS
SERVICE DE GARANTIE
75, RUE J.-A. BOMBARDIER
SHERBROOKE (QUÉBEC)
CANADA, J1L 1W3

N° DU TÉLÉCOPIEUR: 819-566-3590