



WATERCRAFT
SERVICE
Bulletin



Date: **February 21, 2007**

Subject: **4TEC's Aluminum Jet Pump
Wear Ring**

No. **2007-8**

YEAR	MODEL	SERIAL NUMBER
2007	4-TEC™ Models With Aluminum Jet Pump	All

Starting with MY 2007 new wear rings are used on 4TEC's models fitted with an aluminum jet pump (RXP®, RXT®, GTX† BVIC and GTI™ rental models). These wear rings are made of a new material, polyethylene UHMW, developed to increase significantly durability when used in non abusive conditions.

It was reported that these wear rings are quite difficult to install into pump housings even when using a harbour or hydraulic press. This situation can be explained by the fact that the outer diameter was increased and by the lack of chamfer to ease installation. To remedy this issue we have added chamfers on both extremities to ease alignment during installation.

NOTE: A harbour or hydraulic press will still be required for installation due to the wear ring increased outer diameter.

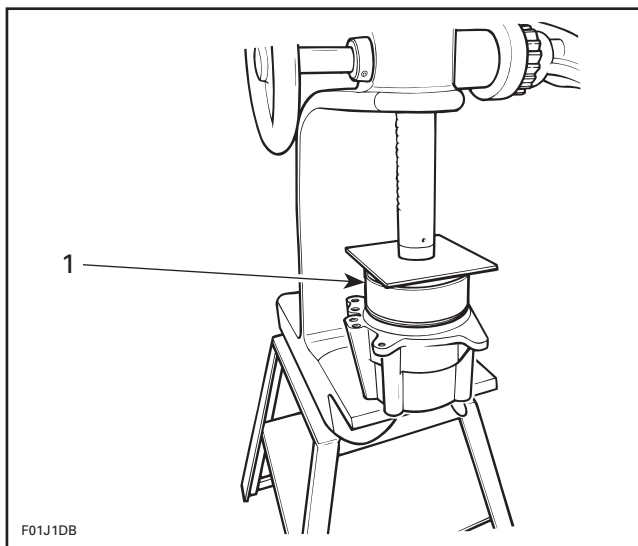

1. Install wear ring into jet pump housing as shown.

Models	Obsolete Original wear ring P/N	Available Chamfered wear ring P/N
RXP, RXT, GTX† BVIC	267 000 338	267 000 372
GTI rental	267 000 341	267 000 374

† GTX is a registered trademark of Castrol Ltd, used under license.

Wear rings (P/N 267 000 338) and (P/N 267 000 341) were available from parts inventory solely since December 2006 but were removed from our inventory recently. If you have ordered and have one of these wear rings for service parts and are experiencing difficulty at installation, simply discard it and submit a parts claim.

Chamfered wear rings (P/N 267 000 372) and (P/N 267 000 374) are now available and orders on all previous wear rings will be automatically superseded. These more durable wear rings can be used on previous 4TEC's models fitted with an aluminum jet pump.

NOTE: Plastic jet pumps used on normally aspirated and supercharged 1503 engines still use the same wear ring as before. UHMW wear ring used on GTI rental can not be used on plastic jet pumps since it does not provide enough structural strength to the pump and clearance between impeller and wear ring is larger on GTI rental.