

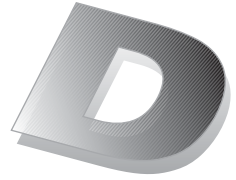

**SIDE-BY-SIDE  
VEHICLES**  
**PREDELIVERY  
Bulletin**



**July 18, 2011**

Subject: **Predelivery Inspection Can-Am™  
Commander™ Series**

No. **2012-1**

YEAR	MODEL	MODEL NUMBER	SERIAL NUMBER
2012	Commander 800	6CCA, 6CCB, 6CCC	All
	Commander 800 XT	6DCA, 6DCC	
	Commander 1000	6ACA, 6ACB	
	Commander 1000 X	6ECA, 6ECB, 6ECC	
	Commander 1000 XT	6BCA, 6BCC, 6BCE, 6BCF, 6BCG	

# TABLE OF CONTENTS

	Page		Page
<b>IMPORTANT NOTICE</b> .....	<b>3</b>	Saving Changes and Exiting the B.U.D.S. Session.....	27
<b>UPDATE SUMMARY</b> .....	<b>4</b>	<b>ASSEMBLY INSPECTION</b> .....	<b>27</b>
<b>UNCRATING</b> .....	<b>5</b>	<b>FINAL INSPECTION</b> .....	<b>27</b>
Crate Cover Removal .....	5	Vehicle Test Run .....	27
Vehicle Removal from Crate .....	5	Vehicle Cleaning .....	27
<b>PARTS TO BE INSTALLED</b> .....	<b>8</b>	Delivery To Customer .....	27
Battery .....	8	<b>TECHNICAL SPECIFICATIONS</b> .....	<b>28</b>
Shock Absorbers Installation.....	9		
Cage Installation .....	11		
Seat Belts Installation (All except CE Models) .....	12		
Seat Belts Installation (CE Models) .....	13		
Shoulder Guards installation .....	13		
Lateral Nets Installation.....	13		
Seats .....	14		
Mirrors (CE Models Only) .....	14		
Mudguards (CE Models Only) .....	15		
Accessories Installation.....	15		
Vehicle Decals.....	15		
<b>FLUIDS</b> .....	<b>15</b>		
Fuel .....	15		
Engine Oil.....	16		
Gearbox Oil.....	17		
Engine Coolant.....	17		
Brake Fluid.....	18		
Front Differential.....	19		
Rear Final Drive Oil.....	19		
<b>SET-UP</b> .....	<b>20</b>		
Tires Pressure .....	20		
Wheel Beadlock .....	20		
Protective Materials.....	21		
Recall or Factory-directed Modification.....	21		
<b>ADJUSTMENTS</b> .....	<b>21</b>		
Suspension Adjustments Guideline.....	21		
Suspension Factory Settings.....	21		
Spring Preload Adjustment (Front and Rear)	22		
Shock Damping Adjustments (Front and Rear).....	22		
<b>B.U.D.S. PROGRAMMING</b> .....	<b>23</b>		
Diagnostic Connector Location .....	23		
Connecting the PC to the Vehicle .....	24		
How to Establish Communication Using B.U.D.S. Software .....	25		

## IMPORTANT NOTICE

This bulletin must be used in conjunction with the check list enclosed in the bag with the *OPERATOR'S GUIDE*. Make sure that *PREDELIVERY CHECK LIST* is completed and signed.

### WARNING

To obtain warranty coverage, predelivery procedures must be performed by an authorized BRP Can-Am SSV dealer/distributor. Apply all necessary torques as indicated.

**NOTE:** The information and components/system descriptions contained in this document are correct at the time of publication. BRP however, maintains a policy of continuous improvement of its products without imposing upon itself any obligation to install them on products previously manufactured.

Due to late changes, there might be some differences between the manufactured product and the descriptions and/or specifications in this document. BRP reserves the right at any time to discontinue or change specifications, designs, features, models or equipment without incurring obligation.

The illustrations in this document show the typical construction of the different assemblies and may not reproduce the full detail or exact shape of the parts. However, they represent parts that have the same or similar function.

The content of this bulletin is designed as a guideline only. All mechanics performing predelivery procedures should have attended the current model year service training.

Further information or inquiries should be directed to your service representative and/or specific *SHOP MANUAL* sections.

Please complete the *PREDELIVERY CHECK LIST* for each vehicle and retain a customer-signed copy.

Make sure the customer receives the *OPERATOR'S GUIDE*, *PREDELIVERY CHECK LIST* signed copy and *SAFETY DVD*.

### WARNING

Torque wrench tightening specifications must be strictly adhered to. Where specified, install new locking devices (e.g. lock tabs, elastic stop nuts). If the efficiency of a locking device is impaired, it must be renewed.

## UPDATE SUMMARY

This summary highlights updates to the Predelivery Inspection for MY2012. It does not supersede procedures detailed further in this publication.

**IMPORTANT:** Technicians should read and apply all procedures in this PDI bulletin as applicable to model.

APPLICABLE TO	UPDATE DESCRIPTION	REFERENCE
All Models	Brake disc cleaning performed during shock absorber installation	Parts to be installed – Shock Absorbers Installation

# UNCRATING

## Crate Cover Removal

1. Carefully lay the crate on its bottom on a firm, level surface.

**NOTICE** Allowing the crate to drop may cause serious damages to vehicle.

2. Remove all screws retaining crate cover to crate base. Screws that are used are Robertson† #2 type that require the use of an appropriate screwdriver.
3. Carefully cut both ends of crate tarpaulin to locate the rear of vehicle.
4. Remove the rear cover end.



5. Assisted by another person, tilt the crate cover.

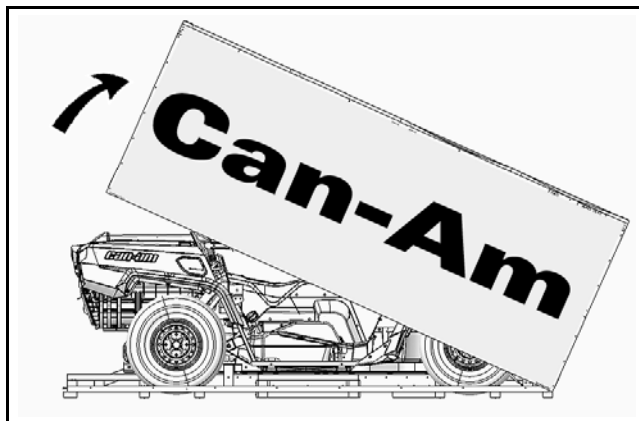

## Vehicle Removal from Crate

1. Remove protective wrapping from the vehicle.

2. Remove both sections of the cage from vehicle.

- 2.1 Cut locking ties securing both sections together.

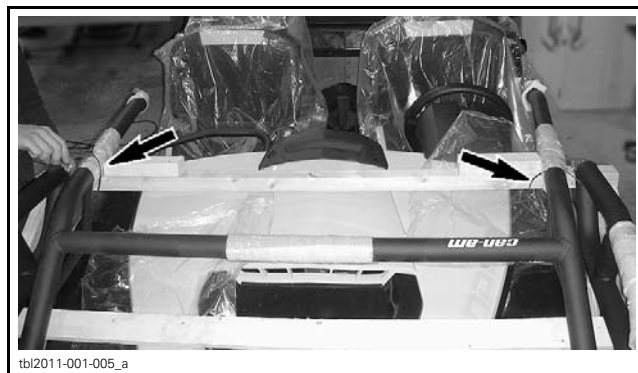

- 2.2 Remove screws securing the rear section of the cage to wood frame.



- 2.3 Remove rear and front sections of cage from vehicle.

† Robertson is a registered trademark of Robertson Inc.

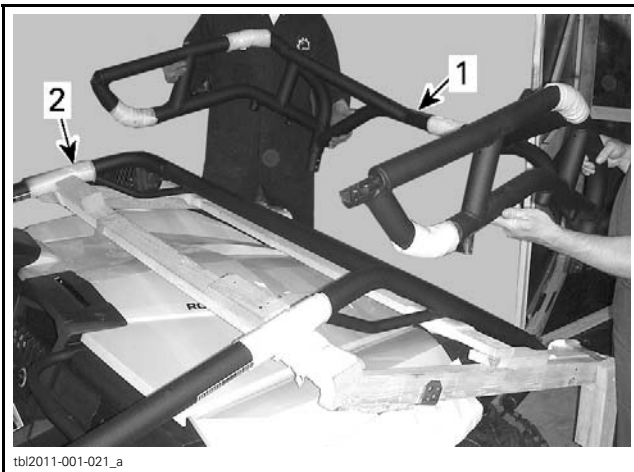

- 1. Rear section of cage
- 2. Front section of cage

3. Remove screws retaining wood frame to steel supports.



- 4. Move the wood frame forward and remove it.
- 5. Remove steel supports from the front fenders. Discard bolts and support.



- 6. Remove seats from vehicle.
  - 6.1 Remove screw securing the top of the backrest to wood support.



6.2 Lift the bottom of the seat and remove seat from vehicle.

7. Cut retaining straps and remove wood support.



8. Cut front and rear straps retaining the vehicle to crate base.

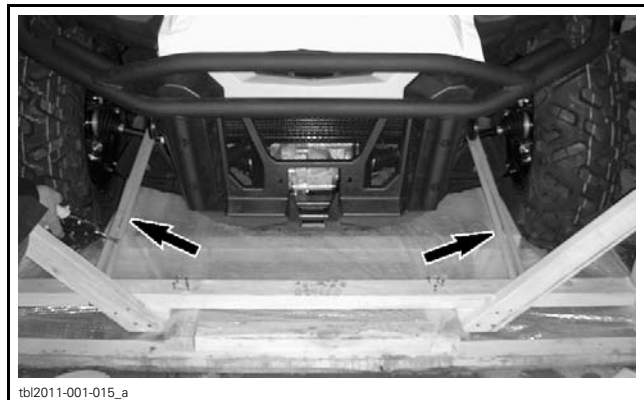

FRONT OF VEHICLE

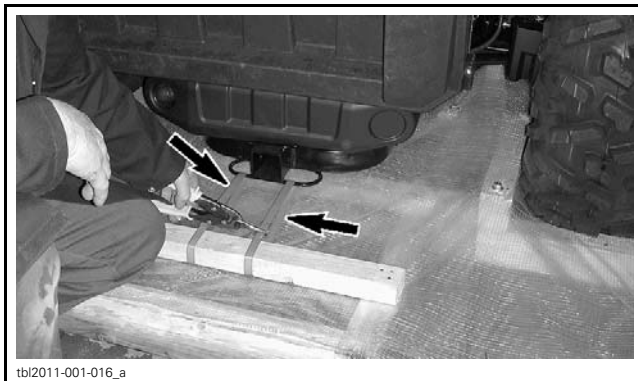

tbl2011-001-016\_a

REAR OF VEHICLE

9. Remove parts from the rear cargo lower compartment.



tbl2011-001-017

10. Cut the front and rear of crate base.



tbl2011-001-055

FRONT OF VEHICLE



tbl2011-001-056

REAR OF VEHICLE

11. Prepare 4 pieces of wood:  
 - 2 pieces of 2x6 by 1.78 m (70 in)  
 - 2 pieces of 2x6 by 1.27 m (50 in)

12. Install the jack under a frame member, in line with a suspension arm.



tbl2011-001-057

13. Lift the front of vehicle just enough to place the pieces of wood (1.78 m (70 in)) between wheel and base crate, as illustrated below.

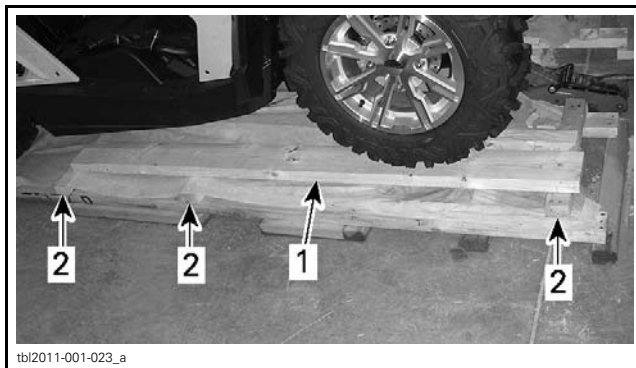

tbl2011-001-023\_a

1. 2x6 by 1.78 m (70 in)  
 2. Crate braces

NOTE: Position the 2x6 over crate braces. The rear of the 2x6 must be halfway on brace.

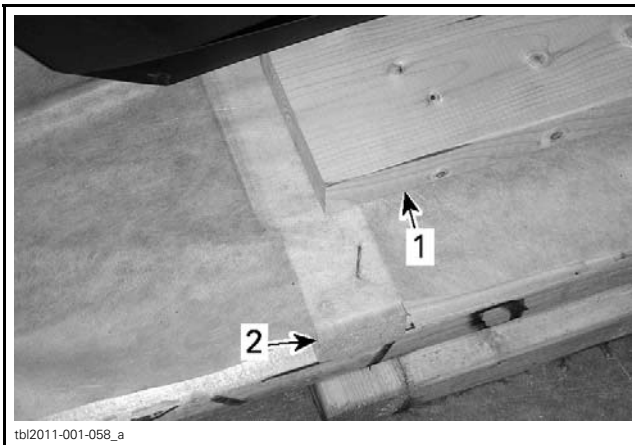

- 1. 2x6
- 2. Crate braces

14. Lower the front of the vehicle and repeat the procedure at the rear.

14.1 Place the jack under the hitch to lift the rear of the vehicle.



14.2 Position the 2x6 on crate braces. Place both 2x6 end to end.

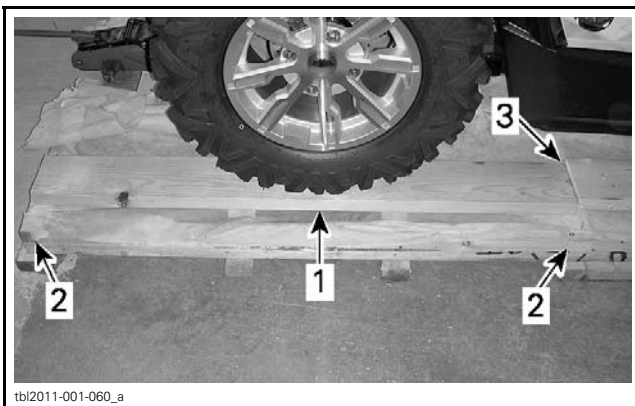

- 1. 2x6 by 1.27 m (50 in)
- 2. Crate braces
- 3. Pieces of wood end to end

15. Lower the vehicle.

16. Place the shift lever on N position and carefully move the vehicle forward out of the crate base.

17. Position the shifter lever on PARK and install the required parts and accessories. Refer to *PARTS TO BE INSTALLED*.

## PARTS TO BE INSTALLED

Ensure that the following parts are provided with the vehicle.

DESCRIPTION	QTY
Front shock absorber kit	1
Rear shock absorber kit	1
Shoulder guard	2
Predelivery kit	1
Can-Am decal (X model only)	1
Mudguard kit (CE models only)	1
Mirrors (CE models only)	1

## Battery

### Battery Removal

**⚠ WARNING**

Battery BLACK (-) lead must always be disconnected first and connected last. Never charge or boost battery while installed on vehicle.

1. From underneath dash, unscrew battery holder retaining nut.
2. Remove battery holder.

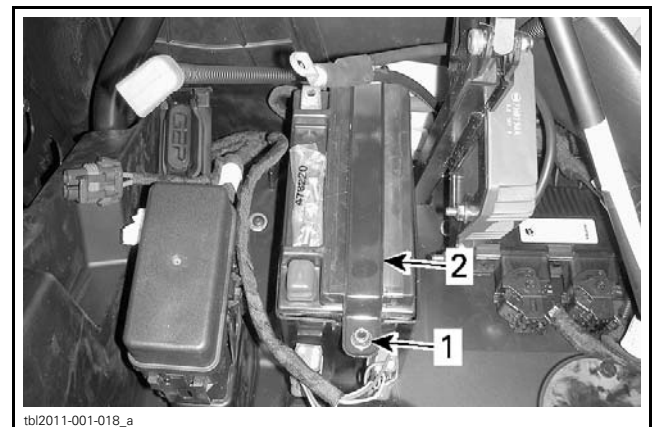

- 1. Bracket retaining nut
- 2. Battery holder

3. Remove the battery. Keep the bag with battery fastener for installation.



## Battery Preparation

Refer to the ***CAN-AM SIDE-BY-SIDE VEHICLES BATTERIES ACTIVATION, CHARGING AND MAINTENANCE BULLETIN (2012-4)*** and to instructions notice attached to battery for proper activating, charging and maintenance procedure.

## Battery Installation

NOTE: The battery should be installed only when properly activated and charged.

1. Install the battery in its rack. Make sure to position the negative post upwards.
2. Install battery holder and tighten the retaining nut.

PARTS	TORQUE
Battery holder nut	10 N•m (89 lbf•in)

3. Connect the RED (+) lead using provided screw and nut.
4. Connect the BLACK (-) lead on the top post.

## Shock Absorbers Installation

### Shock Absorbers Identification

When installing shock absorbers, make sure do not mix front and rear shock absorbers.

#### *All Models except Commander X*

Front and rear shock absorbers can be easily identified by comparing the lower attachment point.

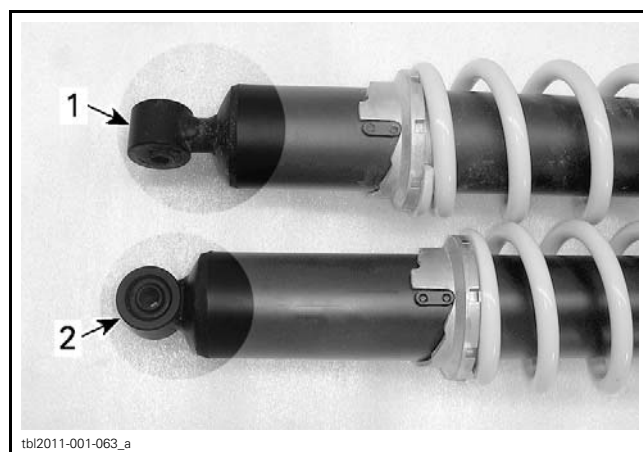

1. Rear shock absorber
2. Front shock absorber

Also, the fourth digit of the spring part number indicated on one of the upper coil may help for the identification.

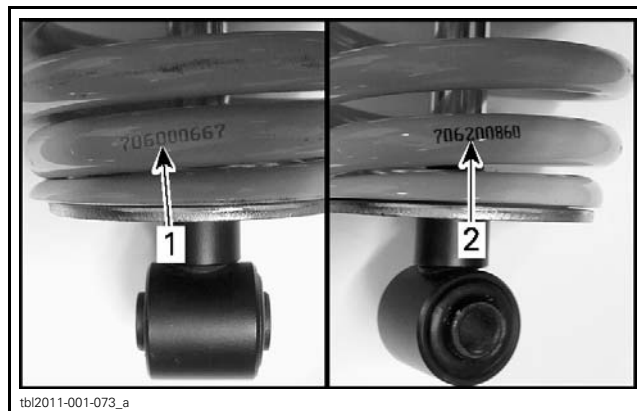

1. 0 = Rear shock absorber
2. 2 = Front shock absorber

#### *Commander X*

Front and rear shock absorbers can be easily identified by comparing the bottom bumper and the position of the low speed compression adjuster.

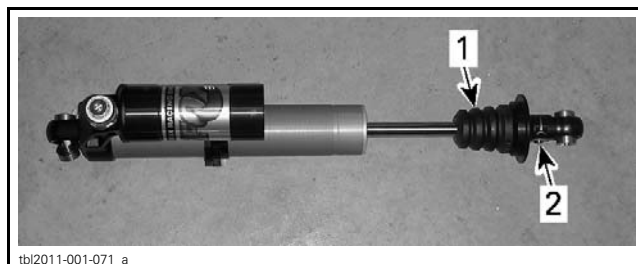

FRONT SHOCK ABSORBER – SPRING REMOVED FOR CLARITY

1. Long bumper
2. Low speed compression adjuster on the side

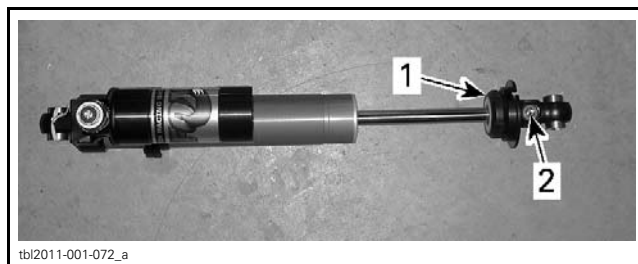

REAR SHOCK ABSORBER – SPRING REMOVED FOR CLARITY

1. Short bumper
2. Low speed compression adjuster on the top

### Rear Shock Absorber Installation

1. Block front wheels.
2. Loosen wheel lug nuts.
3. Open cargo box.
4. Place the jack under the hitch and lift the rear of vehicle.
5. Install jack stands to support the vehicle.
6. Remove wheels.
7. Remove the suspension bracket. Discard bolts and nuts.
8. Install shock absorbers.

PDI KIT PARTS	QTY
M10 x 55 hexagonal flange bolts	4
M10 elastic flange nuts	4

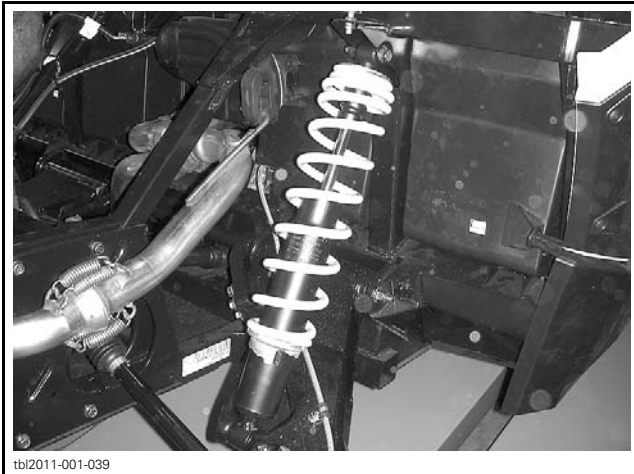

tbi2011-001-039

STD AND XT MODELS

NOTE: On X model, place the reservoir rearwards.

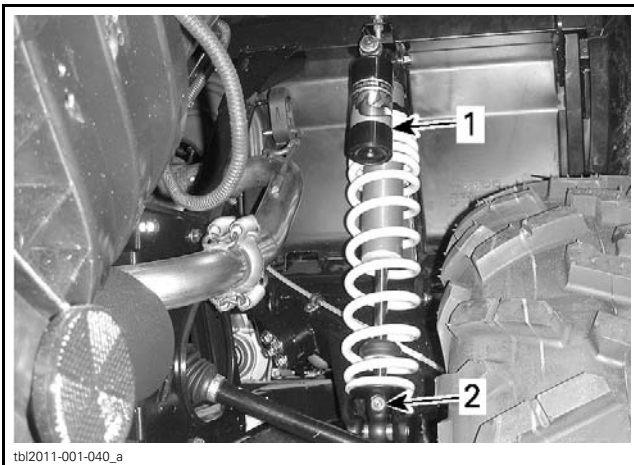

tbi2011-001-040\_a

X MODEL

1. Reservoir facing rearward
2. Low speed compression adjuster facing rearward

PARTS	TORQUE
Shock absorber nuts	48 N•m (35 lbf•ft)

9. Clean brake disc. Use the XPS BRAKES AND PARTS CLEANER (P/N 219 701 705) and a clean rag.

**NOTICE** A thin layer of anticorrosion product can be present on the brake disc and must be removed before using the vehicle. Not conforming to this procedure may lead to a brake chattering and the brake pads replacement would be necessary to solve the problem.

10. Install wheels.

11. Lower the vehicle and remove the jack.

12. Tighten wheel lug nuts.

PARTS	TORQUE
Wheel lug nuts	100 N•m (74 lbf•ft)

13. Close the cargo box.

### Front Shock Absorber

1. Block rear wheels.
2. Loosen wheel lug nuts.
3. Lift the front of vehicle and support it securely.
  - 3.1 Insert the jack under the vehicle by the side, behind front wheels.
  - 3.2 Place the jack under the central beam.
  - 3.3 Lift the front of vehicle.
4. Remove front wheels.

NOTE: Wheels removal is not necessary but allow more room.

5. Remove the suspension brackets. Discard bolts and nuts.

6. Install shock absorbers.

NOTE: Make sure to position nuts rearward.

PDI KIT PARTS	QTY
M10 x 55 hexagonal flange bolts	4
M10 elastic flange nuts	4

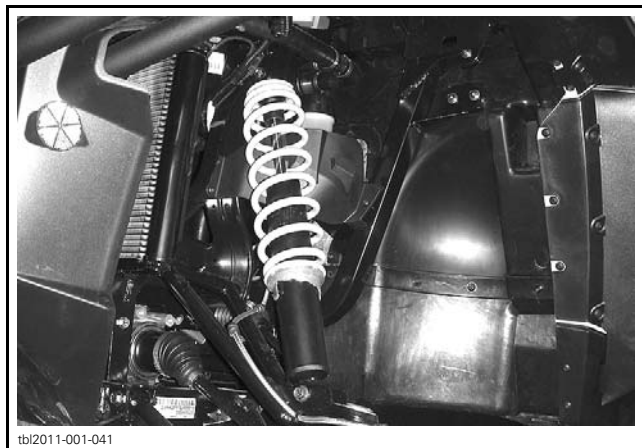

tbi2011-001-041

STD AND XT MODELS

NOTE: On X model, place the reservoir outwards.

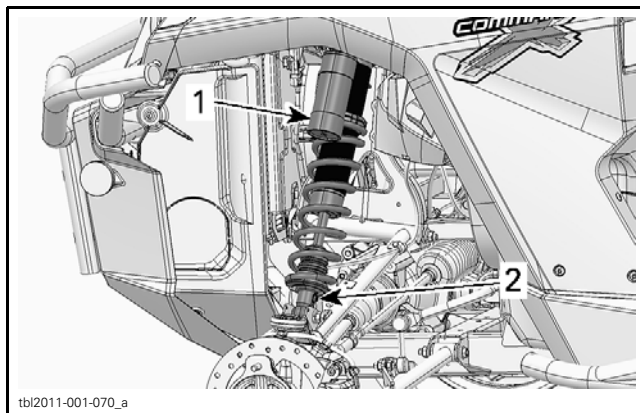

tbi2011-001-070\_a

**LH SIDE OF THE VEHICLE**

1. Reservoir facing outside
2. Low speed compression adjuster facing rearward

PARTS	TORQUE
Shock absorber nuts	48 N•m (35 lbf•ft)

7. Clean brake disc. Use the XPS BRAKES AND PARTS CLEANER (P/N 219 701 705) and a clean rag.

**NOTICE** A thin layer of anticorrosion product can be present on the brake disc and must be removed before using the vehicle. Not conforming to this procedure may lead to a brake chattering and the brake pads replacement would be necessary to solve the problem.

8. Install wheels.
9. Lower the vehicle.
10. Tighten wheel lug nuts.

PARTS	TORQUE
Wheel lug nuts	100 N•m (74 lbf•ft)

## Cage Installation

1. Assemble the cage.

PDI KIT PARTS	QTY
M10 x 30 TORX screws	4

**NOTE: DO NOT TIGHTEN** screws until installation.

2. On **X model**, install the Can-Am decal on the front tube of cage.
  - 2.1 Clean the right portion of the front tube.
  - 2.2 Install the decal.

DECAL POSITION
100 mm (4 in) from right tube



tbi2011-001-042

3. Open the rear cargo box.
  4. On both side of vehicle, remove support plates.
- NOTE:** Keep screws for reinstallation.



tbi2011-001-043\_a

**LH SIDE OF VEHICLE SHOWN**

1. Support plate

5. Cut locking ties securing the seat belts.

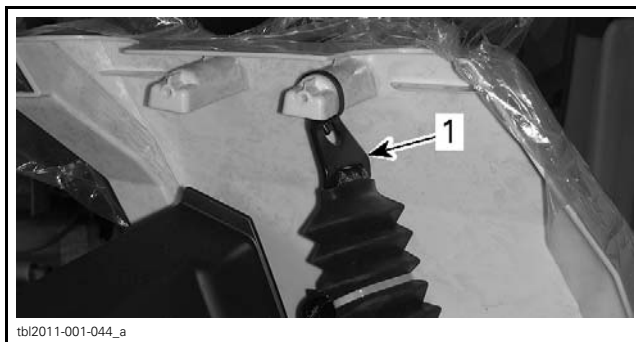

tbi2011-001-044\_a

**LH SIDE OF VEHICLE SHOWN**

1. Seat belt attachment

6. Using a hoist, lift the cage assembly over the vehicle and carefully position it on vehicle. Insert the rear of cage first.

**NOTE:** As an alternate method, 1 person at each attachment point can position the cage on the vehicle.

**CAUTION** To avoid injury or vehicle damages, never handle the cage alone.



tbi2011-0011-024

7. Secure the cage to vehicle.

PDI KIT PARTS	QTY
M10 x 30 TORX screws	8



tbi2011-001-045

RH FRONT CAGE ATTACHMENT POINT



tbi2011-001-046\_a

RH REAR CAGE ATTACHMENT POINT

1. M10 x 30 TORX screws

8. Tighten all cage screws.
- Front attachment points
  - Rear attachment points
  - Joints between front and rear portion of cage.

PARTS	TORQUE
M10 x 30 TORX screws	48 N•m (35 lbf•ft)

9. Secure rear lateral panels using **NEW** push nuts (from PDI kit).



tbi2011-001-047\_a

1. Push nuts

10. Install support plates to retain the top of the rear lateral panels.

PARTS	TORQUE
K50 x 16 TORX screws (previously removed)	Hand torque only

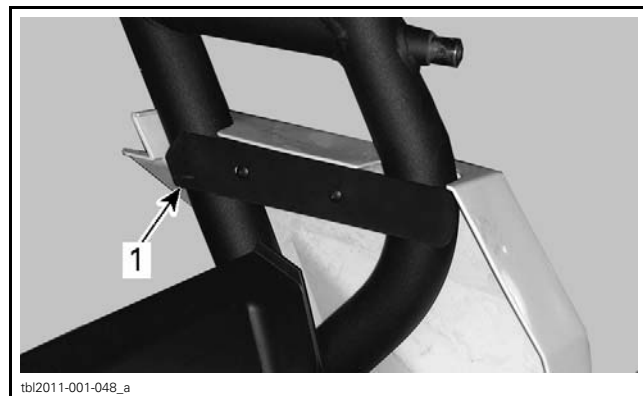

tbi2011-001-048\_a

LH SIDE OF VEHICLE SHOWN

1. Support plate

## Seat Belts Installation (All except CE Models)

NOTE: Gearbox oil level verification should be performed at this moment to facilitate access. See procedures in *FLUIDS*.

1. Cut locking tie attaching seat belt.
2. Secure the seat belt to cage post.

PDI KIT PARTS	QTY
7/16-20 x 1 shoulder bolts	2
7/16-20 elastic nuts	2
Nylon flat washers	4

**NOTICE** Make sure belt is not twisted.

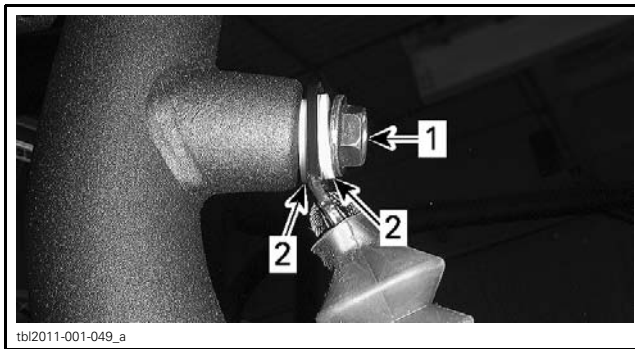

1. Shoulder bolt
2. Nylon flat washer

PART	TORQUE
7/16-20 x 1 shoulder bolts	60 N•m (44 lbf•ft)

## Seat Belts Installation (CE Models)

NOTE: Gearbox oil level should be performed at this moment to facilitate access. See procedures in *FLUIDS*.

1. Cut locking tie attaching seat belt.
2. Secure the seat belt to cage post.

PDI KIT PARTS	QTY
7/16-20 x 1 hexagonal flange bolts	2
7/16-20 elastic nuts	2

**NOTICE** Make sure belt is not twisted.

Position seat belt bracket as per the following illustration.

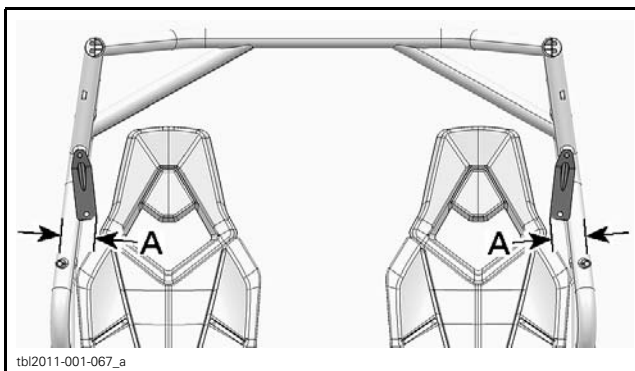

A. Approximately 90 mm (3-17/32 in)

PART	TORQUE
7/16-20 x 1 hexagonal flange bolts	60 N•m (44 lbf•ft)

## Shoulder Guards installation

1. Slide shoulder guard into lateral net hoops.



2. Install shoulder guard to frame.

- 2.1 Secure the top of the shoulder guard.

PDI KIT PARTS	QTY
M6 x 14 TORX screws	2
Support washers	2

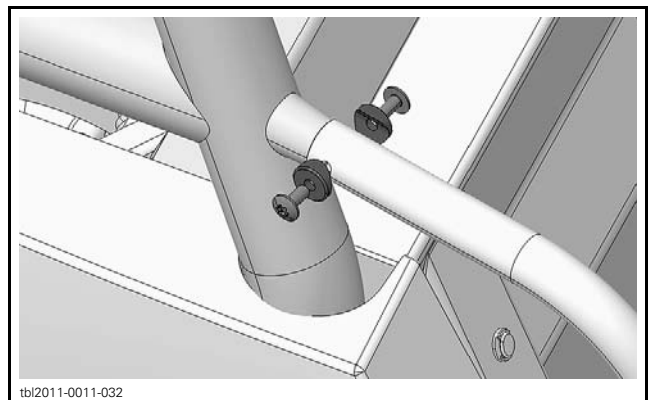

- 2.2 Secure the bottom of the shoulder guard to seat belt mechanism bracket.

PDI KIT PARTS	QTY
M8 x 20 hexagonal flange bolts	2
M8 elastic flange nuts	2

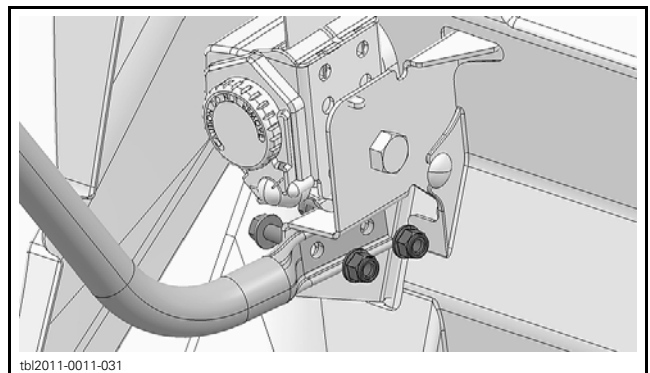

## Lateral Nets Installation

1. Buckle the lateral net.



tbi2011-001-051

2. Attach the top of lateral net to the cage.

PDI KIT PARTS	QTY
M5 x 14 TORX screws	4

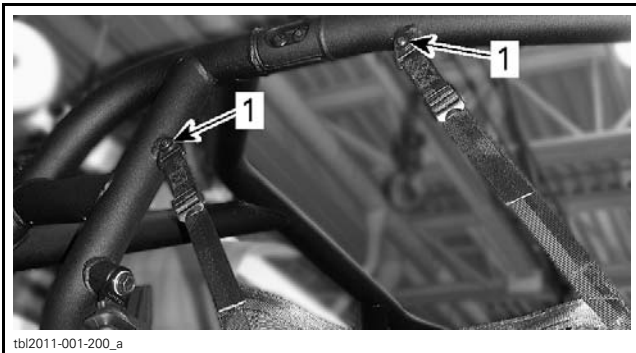

tbi2011-001-200\_a

1. M5 x 14 TORX screws

3. Adjust the length of the lateral net straps.

4. Buckle off the lateral net.

5. Remove and discard the ORANGE belt lock near seat belt mechanism.

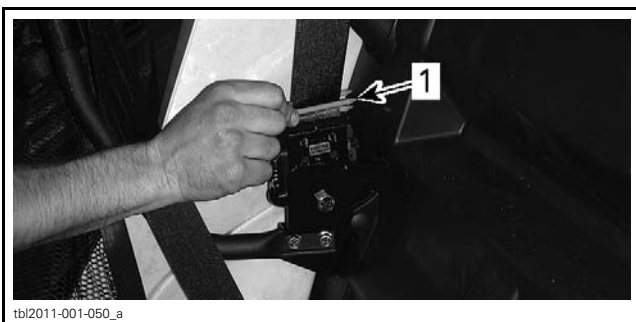

tbi2011-001-050\_a

1. ORANGE belt lock

## Seats

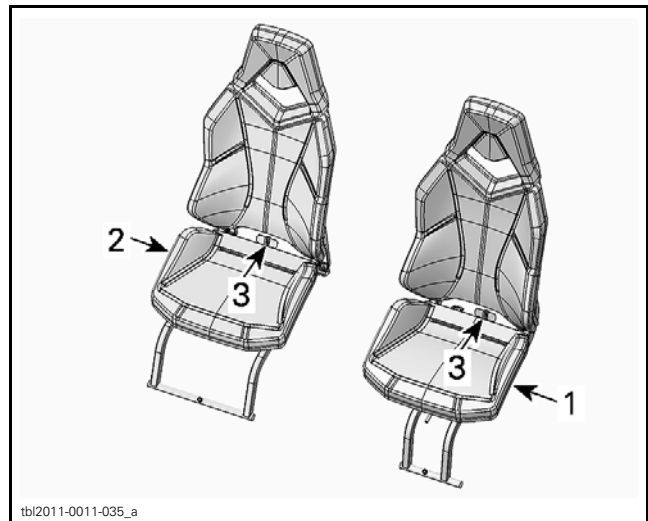

tbi2011-0011-035\_a

1. Driver's seat
2. Passenger's seat
3. Latch to release the seat

1. Insert the seat in the cockpit.
2. Install the seat support into retaining brackets.
3. Push down the backrest to latch the seat.

### Seat Latch Adjustment

If the seat is hard to lock, the seat latch pin must be readjusted.

Loosen retaining screws and reposition the seat latch pin.



tbi2011-001-062

## Mirrors (CE Models Only)

### LH Mirror

1. Assemble the LH mirror on its adaptor.
  - 1.1 Insert threaded rod of mirror into adaptor hole.
  - 1.2 Secure mirror using M8 lock washer and M8 nut. Do not torque yet.

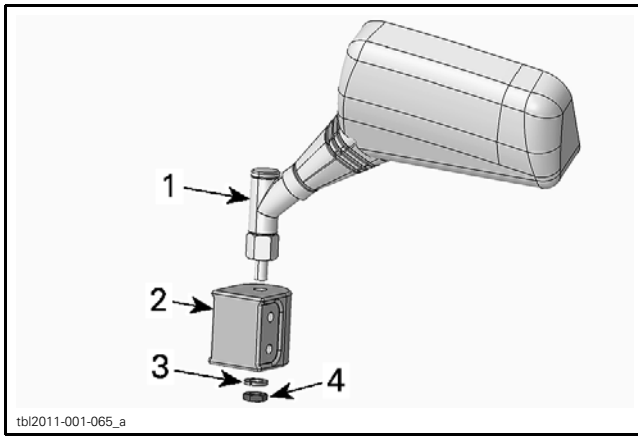

- 1. LH mirror
- 2. Adaptor
- 3. M8 lock washer
- 4. M8 nut

2. Install the LH mirror on cage post.
  - 2.1 Install the U bracket around the LH cage post.
  - 2.2 Install the mirror between U bracket ends.
  - 2.3 Secure them using M6 x 45 Torx screws, M6 flat washers and M6 cap nuts. Do not torque yet.

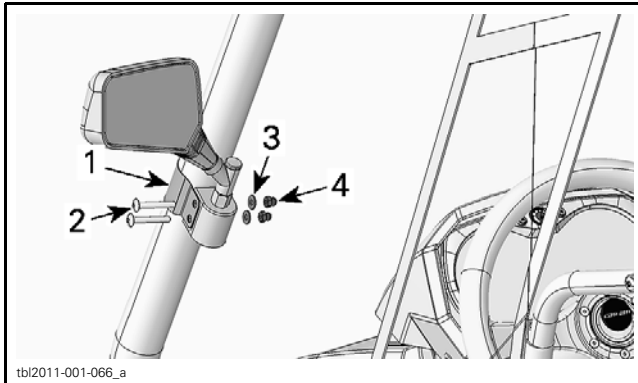

- 1. U bracket
- 2. M6 x 45 Torx screw
- 3. M6 flat washer
- 4. M6 cap nut

3. Position mirror as per owner preference and tighten all nuts.

PART	TORQUE
Mirror nut	24.5 N•m (18 lbf•ft)

PART	TORQUE
M6 cap nut	10 N•m (89 lbf•in)

### Central Mirror

1. Install the U bracket in center of the front transversal cage tube.
2. Install the central mirror.
3. Secure them using M6 x 45 Torx screws, M6 flat washers and M6 cap nuts.

4. Tighten cap nuts.

PART	TORQUE
M6 cap nut	10 N•m (89 lbf•in)

### Mudguards (CE Models Only)

A kit of mudguard is delivered with the vehicle. This kit may be installed or not in accordance with owner preferences.

Install mudguard kit as per their installation instructions (included in the bag).

### Accessories Installation

1. Install accessories (if any) as per their installation instructions (included in each kit).
2. Install any other equipment required by law (if any).

### Vehicle Decals

1. Install decals on vehicle according to customer country language and local legislation.
2. Ensure that the new decals are installed at the same location and over the factory installed decals.

## FLUIDS

All fluids (except fuel) have already been filled at factory, it is only necessary to validate them. However, if refill is needed, use the provided procedure.

### Fuel

1. Add fuel in the fuel reservoir.

**NOTICE** Never mix oil with fuel, these vehicles are equipped with a 4-stroke engine.

**NOTICE** Never place anything over fuel tank cap as this could block the vent hole, leading to engine misfire.

**⚠ WARNING**

- Always stop engine before refueling. Open reservoir cap slowly.
- If a differential pressure condition is noticed (whistling sound heard when loosening fuel reservoir cap) have vehicle inspected and/or repaired before further operation.
- Fuel is flammable and explosive under certain conditions.
- Never use an open flame to check fuel level.
- Never smoke or allow flame or spark in vicinity.
- Always work in a well-ventilated area.
- Never top up the fuel tank before placing the vehicle in a warm area. As temperature increases, fuel expands and may overflow.
- Always wipe off any fuel spillage from the vehicle.
- Never fill a fuel container in the vehicle cargo box or on-board vehicle as electrical static discharge may ignite fuel.

**Recommended Fuel**

Use regular unleaded gasoline, available from most service stations or oxygenated fuel containing a maximum total of 10% of ethanol or methanol. The gasoline used must have the following recommended minimum octane rating.

MINIMUM OCTANE RATING	
Inside North America	87 (R + M)/2
Outside North America	92 RON

**NOTICE** Never experiment with other fuels. The use of non recommended fuel can result in vehicle performance deterioration and damage to critical parts in the fuel system and engine components.

**Engine Oil**

**NOTICE** Do not overfill. Operating the engine with an improper oil level may severely damage engine. Wipe off any oil spillage.

**Recommended Engine Oil**

RECOMMENDED OIL	
SEASON	TYPE
Summer	XPS 4-STROKE BLEND OIL (SUMMER GRADE) (P/N 293 600 121)
Winter	XPS 4-STROKE SYNTHETIC OIL (ALL CLIMATE) (P/N 293 600 112)

**NOTE:** The XPS oil is specially formulated to meet the lubrication requirements of this engine. BRP strongly recommends the use of its XPS 4-stroke oil.

**NOTICE** Damages caused by the use of oil not suitable for this engine will not be covered by the BRP limited warranty.

If XPS oil is not available, use 4-stroke SAE 5W 40 engine oil that meets or exceeds the requirements for API service classification SM, SL or SJ. Always check the API service label certification on the oil container it must contain at least one of the above standards.

**Engine Oil Level Verification**

1. Unscrew dipstick then remove it and wipe clean.

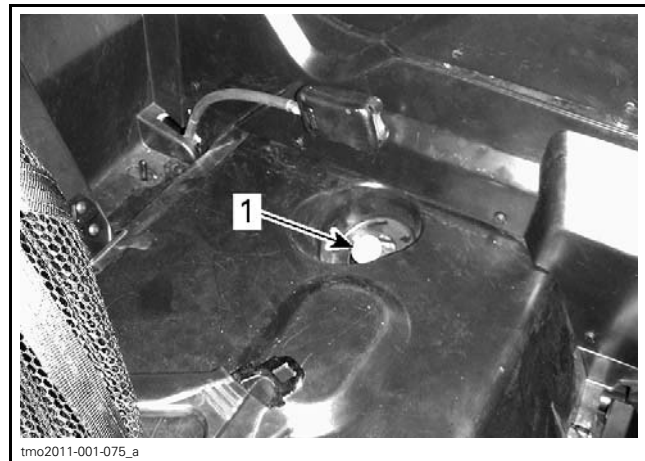

1. Dipstick

2. Reinstall dipstick, screw in it completely.
3. Remove and check oil level. It should be near or equal to the upper mark.



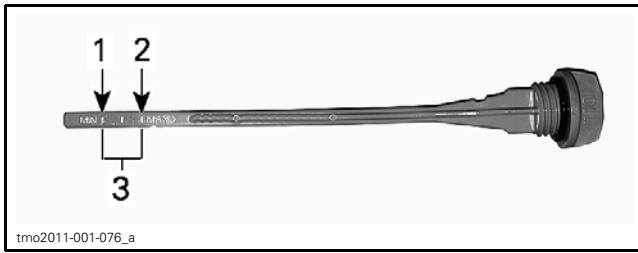

**TYPICAL**

- 1. MIN
- 2. MAX
- 3. Operating range

To add oil, remove the dipstick. Place a funnel into the dipstick tube.

Add a small amount of recommended oil and recheck oil level.

Repeat the above procedures until oil level reaches the dipstick's upper mark.

**NOTE:** Do not overfill. Wipe off any spillage.

Properly tighten dipstick.

## Gearbox Oil

### Recommended Gearbox Oil

GEARBOX OIL	
BRP recommended product	XPS SYNTHETIC GEAR OIL (75W 140) (P/N 293 600 140)
Alternative if not available	75W 140 synthetic gear oil

**NOTICE** Do not use another type of oil when servicing.

### Gearbox Oil Level Verification

Remove the RH lateral console panel and the fuel tank cover.

Check the gearbox oil level by removing the gearbox oil level plug.

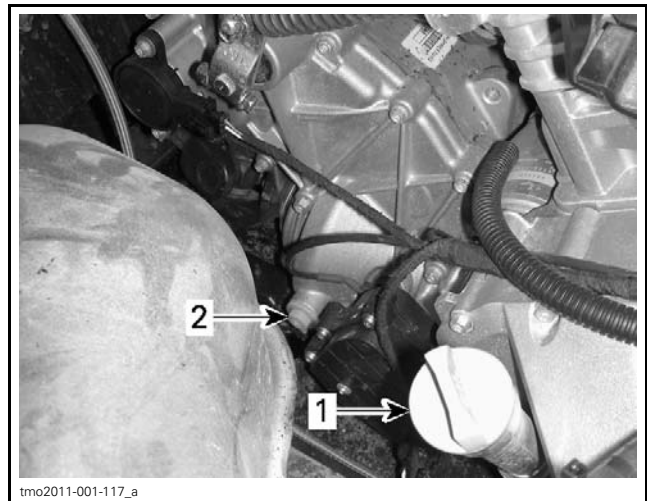

- 1. Engine oil dipstick
- 2. Gearbox oil level plug

The oil should be level with the bottom of the oil level hole.

**NOTICE** Operating the gearbox with an improper oil level may severely damage gearbox.

## Engine Coolant

### Recommended Engine Coolant

COOLANT HEADER	
BRP recommended product	BRP PREMIXED COOLANT (P/N 219 700 362)
Alternative if not available	Distilled water and antifreeze solution (50% distilled water, 50% antifreeze)

**NOTICE** Always use ethylene-glycol antifreeze containing corrosion inhibitors specifically for internal combustion aluminum engines.

### Engine Coolant Level Verification

**⚠ WARNING**  
Check coolant level with engine cold.

Open service cover.

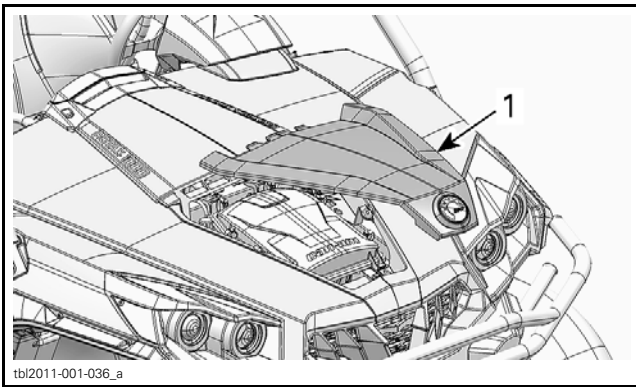

1. Service cover

Locate coolant reservoir.

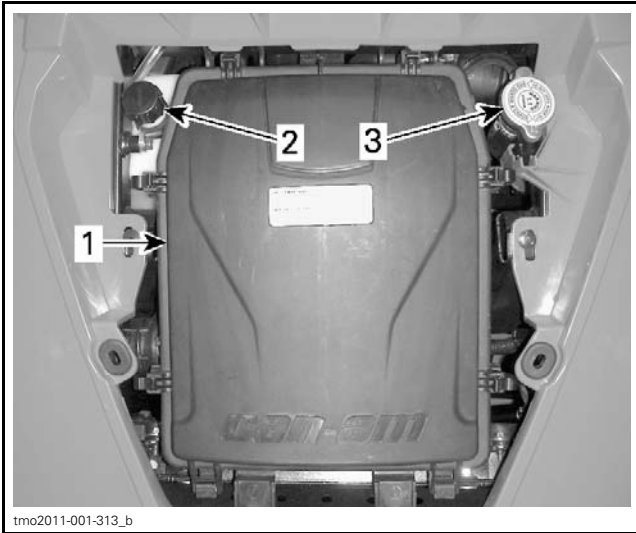

1. Air filter housing cover  
2. Coolant reservoir cap  
3. Radiator cap

Coolant level can be checked by looking at the side of the coolant reservoir under the RH front fender.

With vehicle on a level surface, coolant should be between MIN. and MAX. level marks of coolant reservoir when engine is cold.

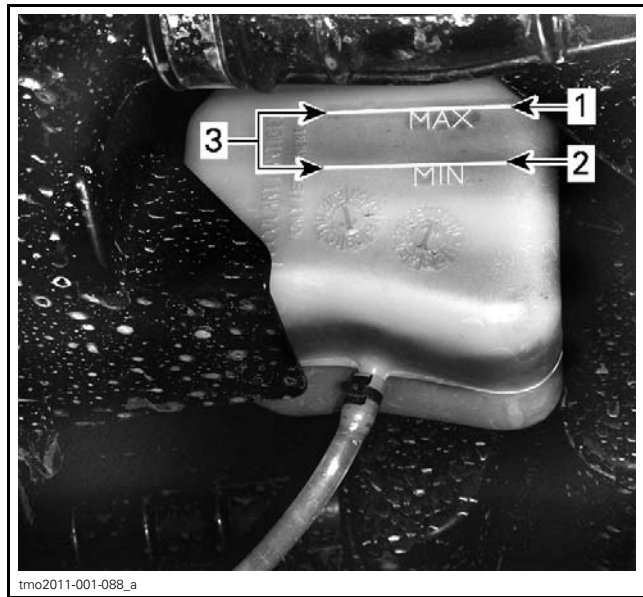

**COOLANT RESERVOIR**

- 1. MAX level
- 2. MIN level
- 3. Operating range

Add coolant up to MAX. mark if required. Use a funnel to avoid spillage. **Do not overfill.**

If coolant is added, check also the level in the radiator. Add coolant if necessary.

Properly reinstall and tighten filler cap.

Reinstall service cover.

## Brake Fluid

**NOTICE** Be sure to clean reservoir caps before removing it to avoid contaminating the oil.

### Recommended Fluid

Always use brake fluid meeting the specification DOT 4 only.

**⚠ WARNING**

To avoid serious damage to the braking system, do not use fluids other than the recommended one, nor mix different fluids for topping up.

### Brake Fluid Reservoir Level Verification

With vehicle on a level surface, check brake fluid in reservoir for proper level. Brake fluid level should be between MIN. and MAX. marks.

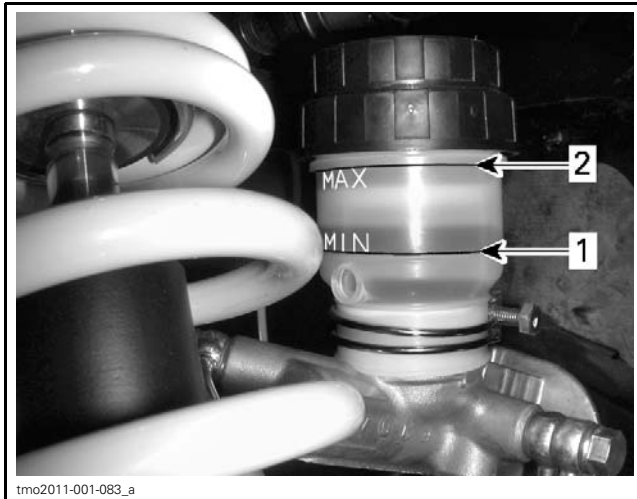

tmo2011-001-083\_a

TYPICAL  
1. MIN  
2. MAX

### Adding Brake Fluid

Clean filler cap before removing.  
Add fluid as required. **Do not overfill.**  
Reinstall the filler cap

### Front Differential

#### Front Differential Recommended Oil

FRONT DIFFERENTIAL OIL	
BRP recommended product	XPS SYNTHETIC GEAR OIL (75W 90) (P/N 293 600 043)
Alternative if not available	75W 90 API GL5 synthetic oil

#### Front Differential Oil Level

Clean filler plug prior to checking oil level.

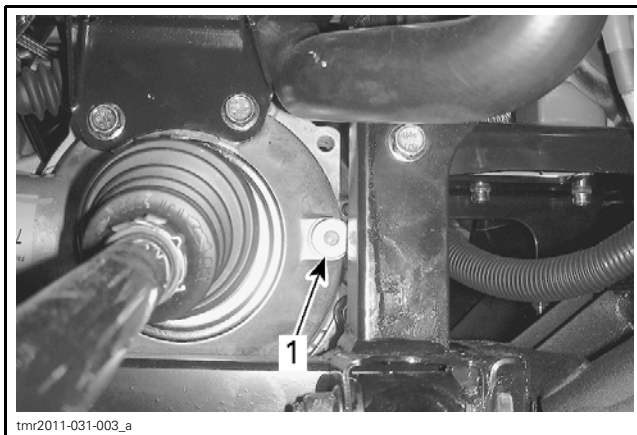

tmr2011-031-003\_a

FRONT RIGHT SIDE OF VEHICLE  
1. Filler plug

With vehicle on a level surface, check oil level by removing filler plug. Oil level must reach the lower edge.

Reinstall filler plug.

TORQUE	
Filler plug	22.5 N•m ± 2.5 N•m (17 lbf•ft ± 2 lbf•ft)

### Rear Final Drive Oil

#### Rear Final Drive Recommended Oil

REAR FINAL DRIVE OIL	
BRP recommended product	XPS SYNTHETIC GEAR OIL (75W 140) (P/N 293 600 140)
Alternative if not available	75W 140 API GL5 synthetic oil

#### Rear Final Drive Oil Level Verification

NOTE: The rear final drive oil is not level with the filler hole.

1. Park vehicle straight on a level surface.
2. Clean filler plug.
3. Remove filler plug.

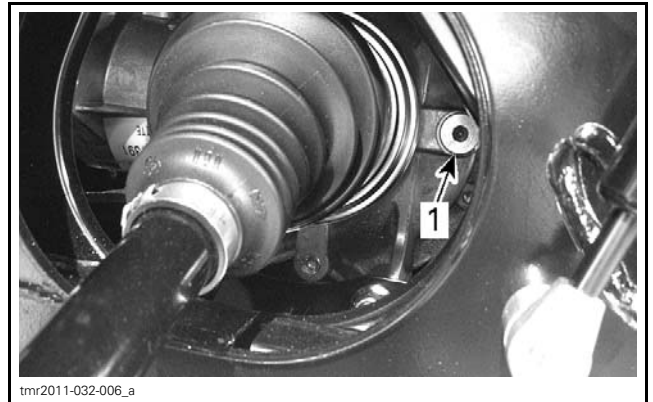

tmr2011-032-006\_a

LH REAR SIDE OF VEHICLE  
1. Filler plug

4. Check rear final drive oil level by inserting a wire with a 90° bend through oil filler hole. Oil level is below filler plug hole.

OIL LEVEL
20 mm ± 5 mm (9/16 in ± 3/16 in)

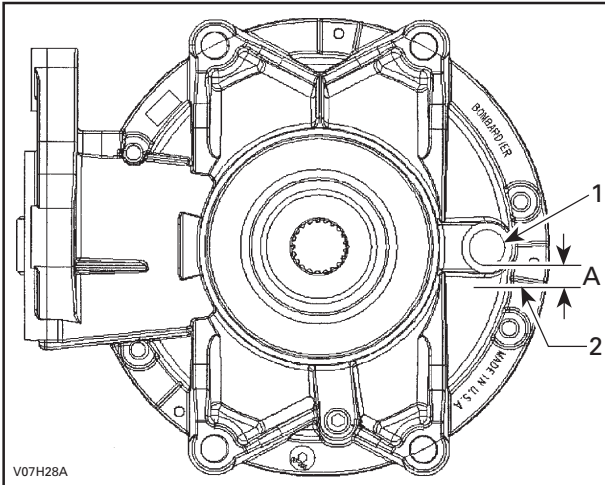

**TYPICAL**

- 1. Filler plug
- 2. Oil level
- A. 20 mm ± 5 mm (9/16 in ± 3/16 in)

- 5. If necessary, add recommended oil.
- 6. Install filler plug.

TORQUE	
Filler plug	22.5 N•m ± 2.5 N•m (17 lbf•ft ± 2 lbf•ft)

## SET-UP

### Tires Pressure

From factory, tires air pressure could be different from the recommended air pressure. To ensure proper seating of the tire bead, inflate tires at 200 kPa (30 PSI) **THEN** set tire pressure to vehicle specification. Refer to the following table.

**NOTICE** Always check pressure when tires are cold.

**NOTICE** Low pressure may cause tire to deflate and rotate on wheel. Overpressure may burst the tire. Always follow recommended pressure. Since tires are low-pressure type, a manual pump should be used.

NOTE: Tire pressure varies with temperature and altitude.

TIRE PRESSURE	FRONT	REAR
MINIMUM	69 kPa (10 PSI)	83 kPa (12 PSI)
MAXIMUM (USE WHEN TOTAL LOAD IS GREATER THAN 180 KG (397 LB))	83 kPa (12 PSI)	152 kPa (22 PSI)

## Wheel Beadlock

### Wheel Beadlock Tightening

*X Model*

**NOTICE** Do not use an impact wrench for tightening beadlock screws in order to avoid to damage them.

Check beadlock screws tightening as per the following sequence.

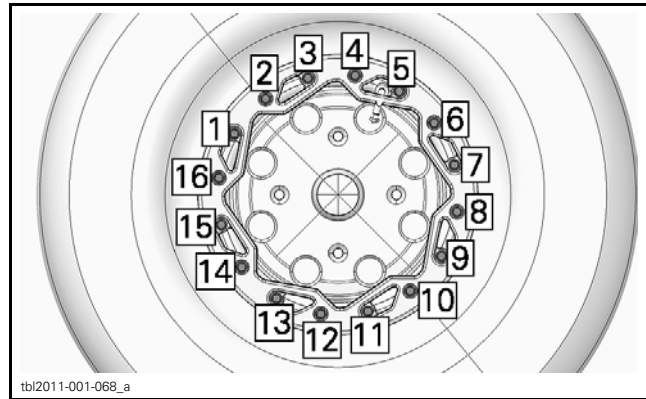

PART	TORQUE
Beadlock screws	8 N•m (71 lbf•in)

NOTE: Tighten screws a few turns at a time to ensure even pressure on the beadlock clamp ring. It is normal that the beadlock clamp ring flexes slightly to match the tire bead.

### Wheel Beadlock Gap Verification

*X Model*

Verify the gap between tire and beadlock clamp ring, it should be practically equal all around the ring.

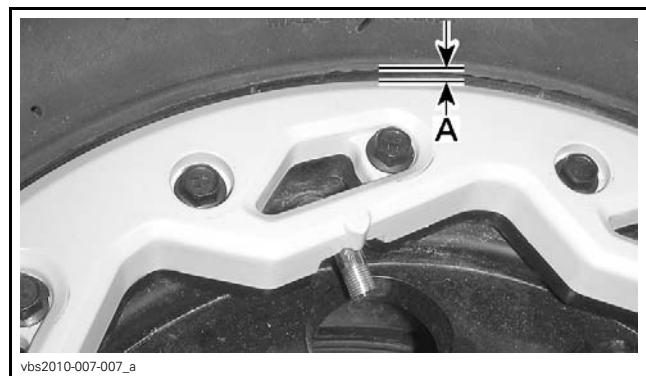

A. Gap equal all around bead lock clamp ring

Readjust if required. Refer to proper shop manual for complete procedure.

## Protective Materials

Ensure that all protective materials are removed from vehicle.

## Recall or Factory-directed Modification

Complete applicable recall or factory-directed modification.

## ADJUSTMENTS

All adjustments have already been performed at factory, it is only necessary to validate them.

## Suspension Adjustments Guideline

Vehicle handling and comfort depend upon suspension adjustments.

### WARNING

Suspension adjustment could affect vehicle handling. Always take time to familiarize yourself with the vehicle's behavior after any suspension adjustment has been made.

Choice of suspension adjustments vary with vehicle load, personal preference, riding speed and terrain condition.

The best way to set up the suspension, is to start from factory settings, then customize each adjustment one at a time.

Front and rear adjustments are interrelated. It may be necessary to readjust the rear shock absorbers after adjusting front shock absorbers for instance.

Test run the vehicle under the same conditions; trail, speed, load, etc. Change one adjustment and retest. Proceed methodically until you are satisfied.

Following are guidelines to fine-tune suspension.

## Suspension Factory Settings

For adjustment procedures, refer to *SPRING PRELOAD ADJUSTMENT (FRONT AND REAR)* and *SHOCK DAMPING ADJUSTMENTS (FRONT AND REAR)* in this section.

To adjust compression and rebound to factory settings, proceed as follows:

1. Turn adjuster clockwise until it stops.
2. Turn adjuster counter clockwise by the specified amount, see table below.

FRONT SUSPENSION FACTORY SETTINGS		
ADJUSTMENT	MODEL	FACTORY SETTING
Spring preload	Base	Cam position 1 (soft)
	XT	Cam position 1 (soft)
	X	Spring length 310 mm (12.2 in)
Compression damping (low speed)	X	12 clicks
Compression damping (high speed)	X	12 clicks
Rebound damping	X	12 clicks

REAR SUSPENSION FACTORY SETTINGS		
ADJUSTMENT	MODEL	FACTORY SETTING
Spring preload	Base	Cam position 1 (soft)
	XT	Cam position 1 (soft)
	X	Spring length 362 mm (14.3 in)
Compression damping (low speed)	X	12 clicks
Compression damping (high speed)	X	12 clicks
Rebound damping	X	12 clicks

## Spring Preload Adjustment (Front and Rear)

Shorten the spring for a firmer ride and rough riding condition or when pulling a trailer.

Lengthen the spring for a softer ride and smooth riding condition.

**⚠ WARNING**

The left and right shock adjustment on front or rear suspension must always be set to the same position. Never adjust one shock only. Uneven adjustment can cause poor handling and loss of stability, which could lead to an accident.

Lift the vehicle. Spring length should be measured without load on the wheels.

### T/A Gas Shock with Reservoir

Adjust by loosening lock ring and turning adjuster ring accordingly. Use tool from vehicle tool kit.



TYPICAL - SPRING NOT SHOWN  
 1. Loosen top lock ring  
 2. Turn adjuster ring accordingly

### Regular Gas Shock

Adjust by turning adjusting cam. Use tool from vehicle tool kit.

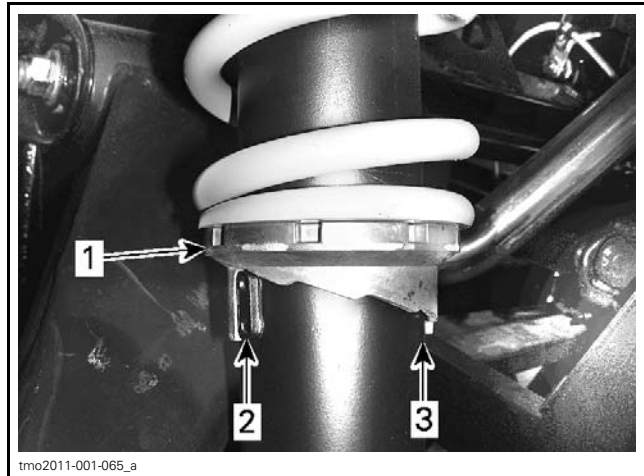

TYPICAL  
 1. Turn adjusting cams  
 2. Smooth adjustment  
 3. Hard adjustment

## Shock Damping Adjustments (Front and Rear)

Perform adjustments **one** position (click) at a time. Test run the vehicle under the same conditions. Proceed methodically until you are satisfied.

### Low Speed Compression Damping (T/A Gas Shock with Reservoir)

Low speed compression damping controls how the shock absorber reacts to a low suspension velocity (slow compression strokes, in most cases when riding at lower speeds).

ACTION	RESULT ON BIG BUMPS
Increasing low speed compression damping force	Firmer compression damping (slow compression)
Decreasing low speed compression damping force	Softer compression damping (slow compression)

Use a flat screwdriver to adjust it.

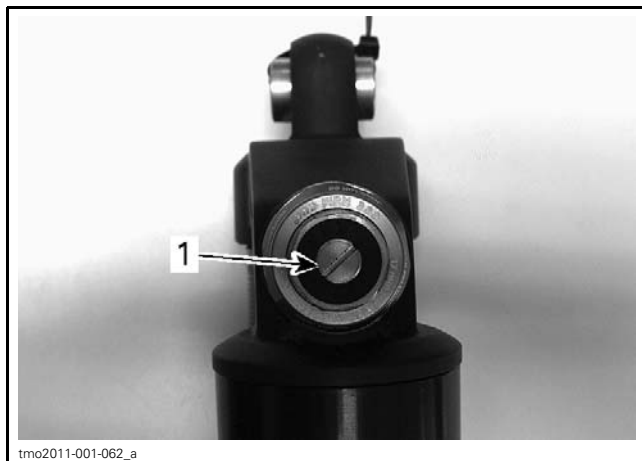

**TYPICAL**  
1. Low speed compression adjuster (flat screwdriver)

Turning it clockwise (H) **increases** shock damping action (stiffer).

Turning it counterclockwise (S) **decreases** shock damping action (softer).

### High Speed Compression Damping (T/A Gas Shock with Reservoir)

High speed compression damping controls how the shock absorber reacts to a high suspension velocity (quick compression strokes, in most cases when riding at higher speeds).

ACTION	RESULT ON SMALL BUMPS
Increasing high speed compression damping force	Firmer compression damping (fast compression)
Decreasing high speed compression damping force	Softer compression damping (fast compression)

Use a 17 mm wrench to adjust it.

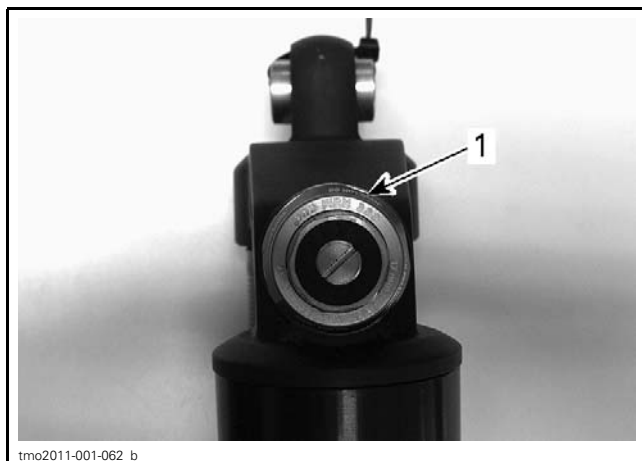

**TYPICAL**  
1. High speed compression adjuster (17 mm socket)

Turning it clockwise (H) **increases** shock damping action (harder).

Turning it counterclockwise (S) **decreases** shock damping action (softer).

### Rebound Damping (All Gas Shock Models)

Use a flat screwdriver to adjust it.



1. Rebound adjuster

Turning it clockwise (H) **increases** shock damping action (harder).

Turning it counterclockwise (S) **decreases** shock damping action (softer).

## B.U.D.S. PROGRAMMING

### Diagnostic Connector Location



The diagnostic connector is located under the dash board on the driver's side. It is stored in it's protective cap on the lower RH side of the battery rack.



1. Diagnostic connector

**NOTE:** Do not mismatch the diagnostic connector with the one on the LH side of the battery rack. This connector has 2 wires and is for manufacturer's use only.

## Connecting the PC to the Vehicle

REQUIRED TOOLS	
MPI-2 DIAGNOSTIC CABLE (P/N 710 000 851)	
MPI-2 INTERFACE CARD (P/N 529 036 018)	

1. Locate the 6-pin diagnostic connector, refer to *DIAGNOSTIC CONNECTOR LOCATION*.
2. Disconnect the 6-pin diagnostic connector from it's holder (protective cap).
3. Connect one end of the MPI-2 diagnostic cable to the vehicle connector.



4. Connect the other end of diagnostic cable to the MPI-2 interface card.



DIAGNOSTIC CABLE CONNECTED TO MPI-2 INTERFACE CARD

**NOTE:** An optional MALE-FEMALE EXTENSION SERIAL CABLE (P/N DB9) available at electronic retail outlets can be used between diagnostic cable and MPI-2 interface. Do not exceed 7.6 m (25 ft).

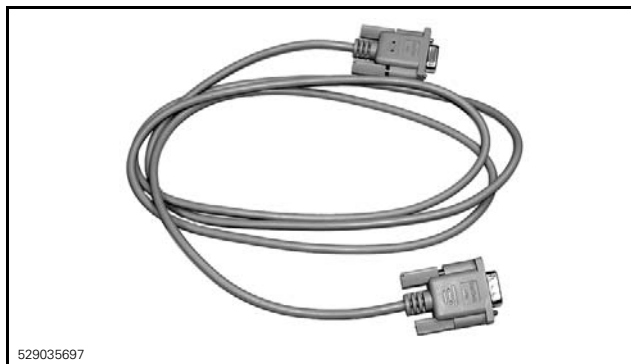

OPTIONAL MALE-FEMALE EXTENSION SERIAL CABLE

5. Connect the MPI-2 interface card to the USB port of a PC (personal computer).





MPI-2 INTERFACE CARD CONNECTED TO USB PORT

## How to Establish Communication Using B.U.D.S. Software

NOTE: Before beginning, check if the latest version of B.U.D.S., available on BOSSWeb for this vehicle, is installed on your computer.

1. Turn ignition switch to ON using any of the key provided with the vehicle. DO NOT start the engine.
2. Start B.U.D.S. and logon.
3. Wait during detection setup.
4. Ensure the status bar shows the Kw2000 protocol and the appropriate number of modules to its right according to the vehicle model.

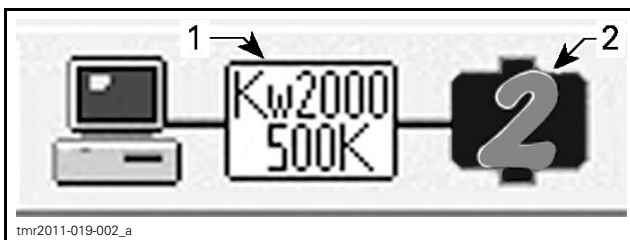

TYPICAL - SUCCESSFUL CONNECTION

1. Connection protocol
2. Number of modules read

5. Click the **Read Data** button.

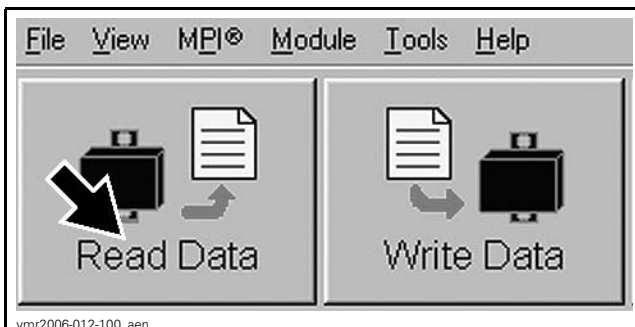

vmr2006-012-100\_aen

B.U.D.S. is now ready for edition, programming or for diagnostics.

### Entering Customer's Name

NOTE: When starting the vehicle, the multifunction display will show the name of the customer.

1. Click on the **VEHICLE** tab to open the vehicle information page.

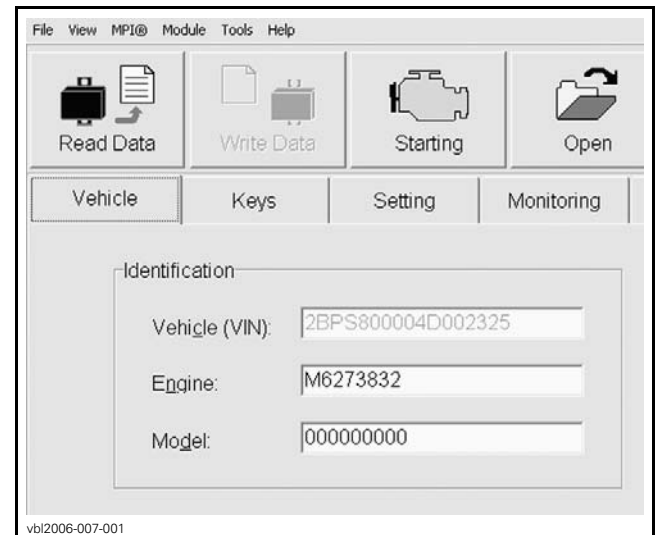

VEHICLE TAB

2. Type the name of the customer.

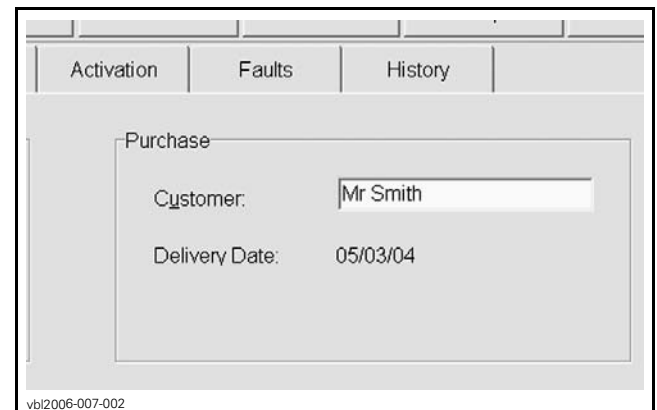

3. Click on **WRITE DATA** to save the information in the vehicle's ECM.

NOTE: After you are finished typing the name, B.U.D.S. automatically updates the Delivery Date on the screen.

### Resetting Trip Hours and Trip Distance

1. Ensure that the **VEHICLE** tab is selected.
2. Click on the **RESET TRIP** buttons to reset the information.



**RESET TRIP BUTTONS**

NOTE: It can also be done directly on the info-center, using the selector button.

**Resetting Last Service**

1. Click on the RESET SERVICE button to reset the informations.

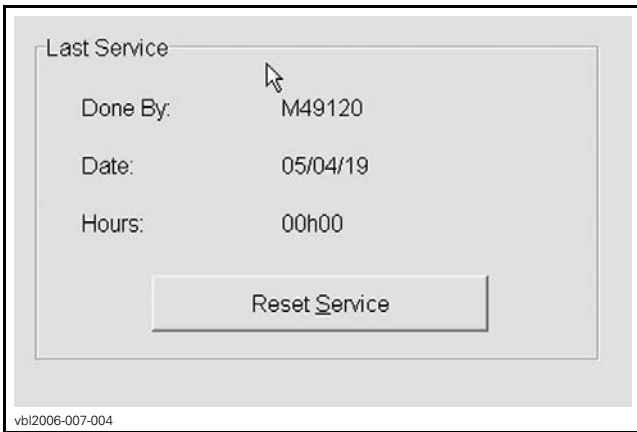

**RESET SERVICE BUTTON**

After each maintenance service, last service should be reset to keep a good tracking of the vehicle service history.

**Programing Keys**

1. Click on KEYS tab.

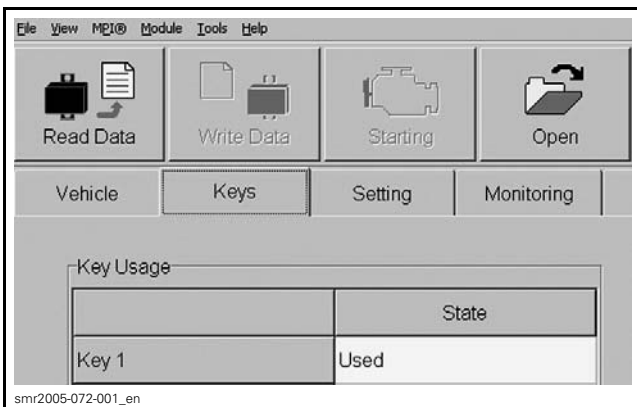

**KEYS TAB**

2. Click on ERASE ALL KEYS button.

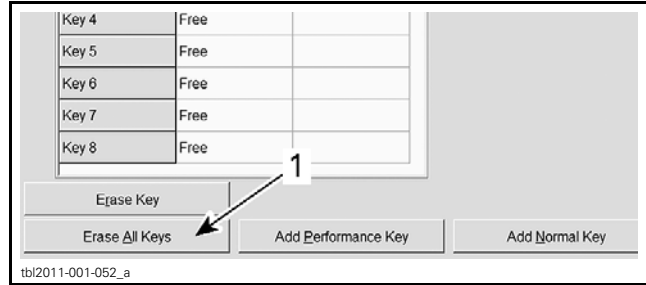

1. Click here to erase all keys

3. Click "YES" to confirm the action.
4. Confirm key color in ignition switch.
5. Program the key by selecting the right type according to chart.

KEY	KEY TYPE
BLACK key	Performance key
GRAY key	Normal key

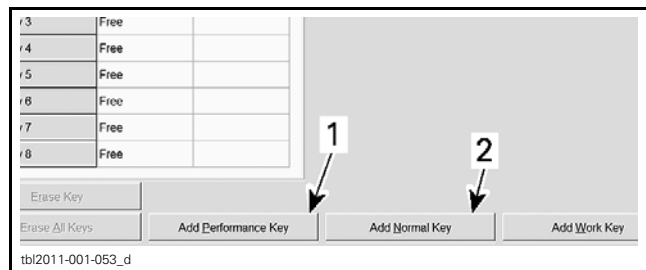

1. Add Performance Key button
2. Add Normal Key button

6. Turn ignition switch to OFF. Remove the key.
7. Install the other key.
8. Turn ignition key to ON position.
9. Program the other key by selecting the right type according to above chart.
10. Repeat steps 6 to 9 to program other keys (8 maximum).

NOTE: The Work key (ORANGE key) is optional.

**Language and Speedometer Reading**

Gauge settings can be changed to accommodate the owner preferences:

- Language (English, French, Spanish, Dutch, etc.)
- Units (Miles or Kilometers)
- Country (NA or CE)
- Time clock (12hr or 24hr)

1. Select SETTING tab in B.U.D.S.
2. Modify the selections in accordance with the owner preferences.

NOTE: No data will be lost when changing this setting.

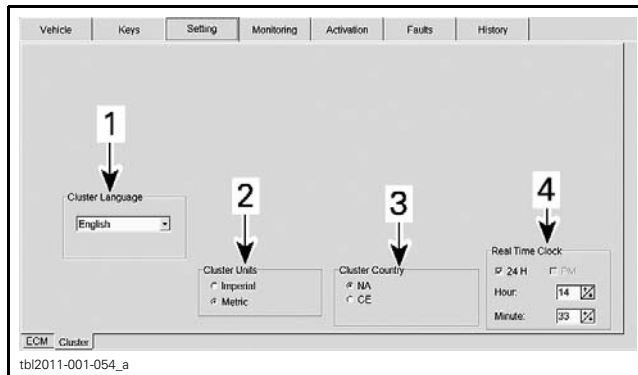

1. Language
2. Units
3. Country
4. Time clock

### Checking for Fault Codes

Click on FAULT tab and check if there are active faults.

- If so, service vehicle then clear the faults in B.U.D.S.

**NOTICE** After a problem has been solved, ensure to clear the fault(s) in the ECM. This will properly reset the appropriate counter(s). This will also records that the problem has been fixed in the ECM memory.

### Saving Changes and Exiting the B.U.D.S. Session

1. Click on WRITE DATA button to transfer new settings and information to the ECM.

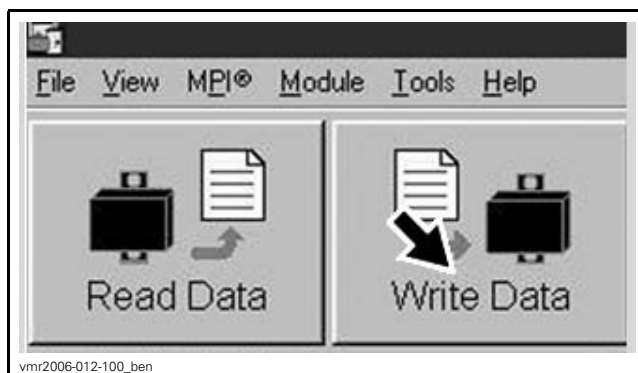

WRITE DATA BUTTON

2. Click on EXIT button to end session.
3. Disconnect all cables and hardware from vehicle.
4. Ensure to reinstall the connector into its housing.

## ASSEMBLY INSPECTION

Inspect the following parts to make sure that the vehicle is properly assembled.

1. Steering operation
2. Suspension arm ball joint cotter pins
3. Tie rod end nuts and cotter pins

## FINAL INSPECTION

### Vehicle Test Run

Ride the vehicle to ensure proper operation of all systems and components.

### Vehicle Cleaning

1. Wash and dry the vehicle.

**NOTICE** Never use a high pressure washer to clean the vehicle. USE LOW PRESSURE ONLY (like a garden hose). The high pressure can cause electrical or mechanical damages.

2. Remove any dirt.
3. Clean vinyl and plastic parts, using a chamois, a flannel cloth or a microfiber cloth with XPS MULTI-PURPOSE CLEANER (P/N 219 701 709).

**NOTICE** It is necessary to use a chamois, a flannel cloth or a microfiber cloth on plastic parts to avoid damaging surfaces. Never clean plastic parts with strong detergent, degreasing agent, paint thinner, acetone, products containing chlorine, etc.

4. Clean the entire vehicle, including metallic parts, with XPS OFF-ROAD VEHICLE WASH (P/N 219 701 702).
5. Painted parts which are damaged should be properly repainted to prevent rust.

## Delivery To Customer

### Before Delivery the Vehicle

Complete the *PREDELIVERY CHECK LIST*.

The customer must read and sign the *PREDELIVERY CHECK LIST*.

Give *OPERATOR'S GUIDE* and *SAFETY DVD* to customer.

Any person who rides this vehicle should read and understand all the information given on hang tag and safety labels before riding.

# TECHNICAL SPECIFICATIONS

MODEL		800R	1000
<b>ENGINE</b>			
Engine type		ROTAX® 810	ROTAX® 1010
		4-stroke, Single Over Head Camshaft (SOHC), liquid cooled	
Number of cylinders		2	
Number of valves		8 valves (mechanical adjustment)	
Bore		91 mm (3.58 in)	91 mm (3.58 in)
Stroke		61.5 mm (2.42 in)	75 mm (2.95 in)
Displacement		799.9 cm <sup>3</sup> (48.81 in <sup>3</sup> )	976 cm <sup>3</sup> (59.56 in <sup>3</sup> )
Exhaust system		Spark arrestor approved by USDA Forest Service	
Air filter		Synthetic paper filter	
<b>LUBRICATION SYSTEM</b>			
Type		Wet sump. Replaceable oil filter	
Oil filter		BRP Rotax paper type, replaceable	
Engine oil	Capacity (oil change with filter)	2.2 L (2.3 qt (U.S. liq.))	
	Recommended	For the summer season, use XPS 4-STROKE BLEND OIL (SUMMER GRADE) (P/N 293 600 121). For the winter season, use XPS 4-STROKE SYNTHETIC OIL (ALL CLIMATE) (P/N 293 600 112). If not not available, use a 5W 40 motor oil that meets the requirements for API service classification SM, SL or SJ	
<b>COOLING SYSTEM</b>			
Coolant	Type	Ethyl glycol/water mix (50% coolant, 50% water). Use BRP PREMIXED COOLANT (P/N 219 700 362) or coolant specifically designed for aluminum engines	
	Capacity	3.85 L (1.02 U.S. gal.)	4.25 L (1.12 U.S. gal.)
<b>CVT TRANSMISSION</b>			
Type		CVT (Continuously Variable Transmission)	
Engagement RPM		1800 RPM	
<b>GEARBOX</b>			
Type		Dual range (HI-LO) with PARK, neutral and reverse	
Gearbox oil	Capacity	450 ml (15 U.S. oz)	
	Recommended	XPS SYNTHETIC GEAR OIL (75W 140) (P/N 293 600 140) or a 75W 140 synthetic gear oil	
<b>ELECTRICAL SYSTEM</b>			
Magneto generator output		650 W	
Ignition system type		IDI (Inductive Discharge Ignition)	
Ignition timing		Not adjustable	
Spark plug	Quantity	2	
	Make and type	NGK DCPR8E	
	Gap	0.7 mm to 0.8 mm (.028 in to .031 in) (not adjustable)	
Engine RPM limiter setting (forward)		8000 RPM	

MODEL			800R	1000
<b>ELECTRICAL SYSTEM (cont'd)</b>				
Battery	Type		Dry battery type	
	Voltage		12 volts	
	Nominal rating		18 A•h	
	Power starter output		0.7 KW	
Headlights			4 x 60 W	
Taillight			8/26 W	
Fuses	Ignition coils		5 A	
	Fan		25 A (fuse breaker)	
	Fuel injectors		5 A	
	Speedometer/speed sensor/taillight		7.5 A	
	Fuel pump		7.5 A	
	Engine control module (ECM)		5 A	
	Accessories		20 A	
	European components		–	5 A
<b>FUEL SYSTEM</b>				
Fuel delivery	Type		Electronic fuel injection with iTC	
Fuel pump	Type		Electric (in fuel tank)	
Idle speed			1250 ± 100 RPM (not adjustable)	
Fuel	Type		Regular unleaded gasoline	
	Minimum octane rating	Inside North America	87 (R+M)/2 or higher	
		Outside North America	92 RON or higher	
Fuel tank capacity			37.8 L (10 U.S. gal.)	
Remaining fuel in fuel tank when display light turns ON			± 12 L (3.2 U.S. gal.)	
<b>DRIVE SYSTEM</b>				
Drive system type			Selectable 2WD/4WD	
Front differential	Recommended oil		XPS SYNTHETIC GEAR OIL (75W 90) (P/N 293 600 043) or 75W 90 API GL5 synthetic oil	
	Oil capacity		500 ml (17 U.S. oz)	
	Type		Visco-lok† front differential	
	Front drive ratio		3.6:1	
Rear final drive oil	Recommended oil		XPS SYNTHETIC GEAR OIL (75W 140) (P/N 293 600 140) or 75W 140 API GL5 synthetic oil	
	Oil capacity		350 ml (11.8 U.S. oz)	
	Type		Shaft driven/single differential	
	Rear drive ratio		3.6:1	
CV joint grease			CV GREASE (P/N 293 550 019)	
Propeller shaft grease			XPS SYNTHETIC GREASE (P/N 293 550 010)	
<b>STEERING</b>				
Steering wheel			Adjustable tilt steering	
Turning radius			240 cm (94.5 in)	
Total toe (vehicle on ground)			0° ± 0.2° ( ± )	
Camber angle (vehicle on ground)			0.7° positive	

TECHNICAL SPECIFICATIONS

MODEL			800R	1000
<b>FRONT SUSPENSION</b>				
Suspension type			Double suspension-arm with dive-control geometry	
Suspension travel			254 mm (10 in)	
Shock absorber	Qty		2	
	Type	Standard	Oil, 5 settings	
		X	HPG Clicker	
		XT	Oil 5 settings	
<b>REAR SUSPENSION</b>				
Suspension type			Torsional Trailing arm Independant (TTI) with external sway bar	
Suspension travel			254 mm (10 in)	
Shock absorber	Qty		2	
	Type	Standard	Oil, 5 settings	
		X	HPG Clicker	
		XT	Oil 5 settings	
<b>BRAKES</b>				
Front brake	Type		Dual 214mm ventilated disc brakes with hydraulic twin-piston calipers	
Rear brake	Type		Single 214mm ventilated disc brake with hydraulic twin-piston caliper	
Brake fluid	Capacity		125 ml (4.2 U.S. oz)	
	Type		DOT 4	
Caliper			Floating	
Brake pad material	Front		Metallic	
	Rear		Metallic	
Minimum bake pad thickness			1 mm (.039 in)	
Minimum brake disc thickness	Front		3.5 mm (.138 in)	
	Rear		4.3 mm (.169 in)	
Maximum brake disc warpage			0.2 mm (.001 ft)	
<b>TIRES</b>				
Pressure	Front		Maximum: 83 kPa (12 PSI) Minimum: 69 kPa (10 PSI)	
	Rear		Maximum: 152 kPa (22 PSI) Minimum: 83 kPa (12 PSI)	
Minimum tire thread depth			3 mm (.118 in)	
Tire Size	Front	Standard	27 x 9 x 12 (in)	
		X	27 X 9 X 12 (in)	
		XT	27 X 9 X 14 (in)	
	Rear	Standard	27 x 11 x 12 (in)	
		X	27 X 11 X 12 (in)	
		XT	27 X 11 X 14 (in)	

MODEL		800R	1000
<b>WHEELS</b>			
Type		Standard	Steel
		X	Aluminum beadlock wheels
		XT	Cast Aluminum
Rim Size	Front	Standard	12 X 6 (in)
		X	12 X 6 (in)
		XT	14 X 7 (in)
	Rear	Standard	12 X 8 (in)
		X	12 X 7.5 (in)
		XT	14 X 8.5 (in)
Wheel nuts torque		100 N•m ± 10 N•m (74 lbf•ft ± 7 lbf•ft)	
<b>CHASSIS</b>			
Cage type		50 mm (2 in) diameter, high strength steel, ROPS-approved cage	
<b>DIMENSIONS</b>			
Overall length		300.4 cm (118.3 in)	
Overall width		148.9 cm (58.6 in)	
Overall height		182.9 cm (72 in)	
Wheelbase		192.4 cm (75.7 in)	
Wheel track	Front	125.7 cm (49.5 in)	
	Rear	121.9 cm (48 in)	
Ground clearance		27.9 cm (11 in)	
<b>LOADING CAPACITY AND WEIGHT</b>			
Dry weight		584 kg (1,287 lb)	587 kg (1,295 lb)
Weight Distribution (Front / Rear)		44 / 56	
Cargo Box Capacity	Total	272 kg (600 lb)	
	Upper	181 kg (400 lb)	
	Lower	272 kg (600 lb)	
Total vehicle load allowed (including driver, passenger, all other loads and added accessories)		363 kg (800 lb)	
Gross vehicle weight rating		990 kg (2,183 lb)	
Towing capacity		680 kg (1,500 lb)	