

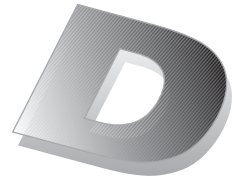

ROADSTER
PREDELIVERY
Bulletin



November 25, 2010 Subject: **Can-Am™ Spyder™ RT Predelivery Instructions**

No. **2011-2**

REVISION 1
March 23, 2011

YEAR	MODEL	MODEL NUMBER	COUNTRY	PREDELIVERY KIT	SERIAL NUMBER
2011	Spyder® RT SM5	A3BA	Canada United States of America	(P/N 703 100 263)	All
		A3BB	Europe		
	Spyder RT Audio & Convenience SM5	A7BA, A7BC	Canada United States of America		
	Spyder RT Audio & Convenience SE5™	A9BA, A9BC	Canada United States of America		
	Spyder RT Techno SM5	A7BD	Europe		
	Spyder RT Techno SE5	A9BB	Europe		
	Spyder RT-S SM5	B5BA, B5BC, B5BD, B5BE	Canada United States of America		
	Spyder RT-S SE5	A4BA, A4BC, A4BE, A4BG	Canada United States of America		
		A4BB, A4BD, A4BF, A4BH	Europe		
	Spyder RT Limited SE5	B9BA	Canada United States of America		
B9BB		Europe			

► Underlined text(s) between arrows is (are) modified element(s) to the original publication. ◀

***NEW** – in title = Revised or new procedure compared to previous model year.

TABLE OF CONTENTS

	Page		Page
IMPORTANT NOTICE	3	Delivery to Customer	36
UNCRATING	4	SPECIFICATIONS	37
Crate Cover Removal	4		
Parts and Sub-crate Removal	4		
*NEW – Parts Check	5		
*NEW – Lifting the Front of Vehicle	6		
*NEW – Front Wheels Installation	8		
▶Tire Pressure◀	9		
*NEW – Vehicle Removal	9		
PARTS TO BE INSTALLED	11		
Front Cargo Module	11		
*NEW – Battery Charging and Installation ..	16		
Front Cargo Module (continued)	18		
Mudguards	19		
Front Fenders	20		
Windshield	21		
*NEW – Antenna (Option Package)	21		
Hang Tag and Safety Labels	22		
Licence Plate	22		
Accessories Installation	23		
Vehicle Decals	23		
Key Barrel - Trailer RT 622	23		
FLUIDS	23		
General Guidelines	23		
Fuel	23		
Engine Oil	24		
Clutch Fluid (SM5 Model)	25		
Engine Coolant	26		
Brake Fluid	27		
ADJUSTMENTS	27		
Guidelines	27		
Drive Belt	27		
Clutch Lever	29		
Suspension	29		
Lights	30		
B.U.D.S. Programming	32		
ASSEMBLY INSPECTION	34		
FINAL INSPECTION	35		
Vehicle Test Run	35		
Vehicle Cleaning	36		

IMPORTANT NOTICE

This bulletin must be used in conjunction with the check list enclosed in the bag with the *OPERATOR'S GUIDE*. Make sure that Spyder roadster *PRE DELIVERY CHECK LIST* is completed and signed.

WARNING

To obtain warranty coverage, predelivery procedures must be performed by an authorized BRP Can-Am roadster dealer/distributor. Apply all necessary torques as indicated.

NOTE: The information and components/system descriptions contained in this document are correct at the time of publication. BRP however, maintains a policy of continuous improvement of its products without imposing upon itself any obligation to install them on products previously manufactured.

Due to late changes, there might be some differences between the manufactured product and the descriptions and/or specifications in this document. BRP reserves the right at any time to discontinue or change specifications, designs, features, models or equipment without incurring obligation.

The illustrations in this document show the typical construction of the different assemblies and may not reproduce the full detail or exact shape of the parts. However, they represent parts that have the same or similar function.

The content of this bulletin is designed as a guideline only. All mechanics performing predelivery procedures should have attended the current model-year service training.

Further information or inquiries should be directed to your service representative and specific *SHOP MANUAL* sections.

Make sure the customer receives the *OPERATOR'S GUIDE*, *PREDELIVERY CHECK LIST* signed copy and *SAFETY DVD*

WARNING

Torque wrench tightening specifications must be strictly adhered to. Where specified, install new locking devices (e.g. lock tabs, elastic stop nuts). If the efficiency of a locking device is impaired, it must be renewed.

UNCRATING

Crate Cover Removal

NOTICE Allowing the crate to drop may cause serious damage to vehicle.

1. Position the crate on a firm, level surface.
2. Carefully cut both ends of crate tarpaulin to locate the front of vehicle.

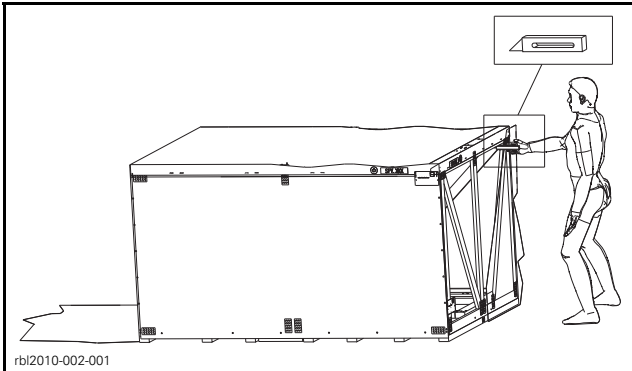

CUT BOTH END OF CRATE TARPAULIN

3. Remove all screws holding crate cover to crate base.
4. Tilt cover from the front side of the vehicle then pull cover toward you to clear vehicle fascia.

NOTICE Do not raise cover vertically. Tilt cover located on the front side of the vehicle. Refer to illustration.

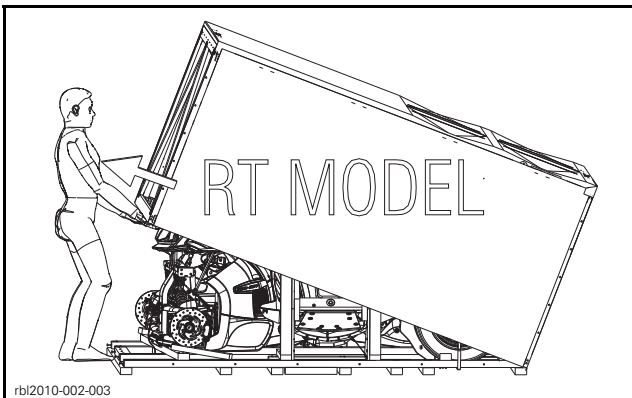

TILT COVER THEN PULL IT

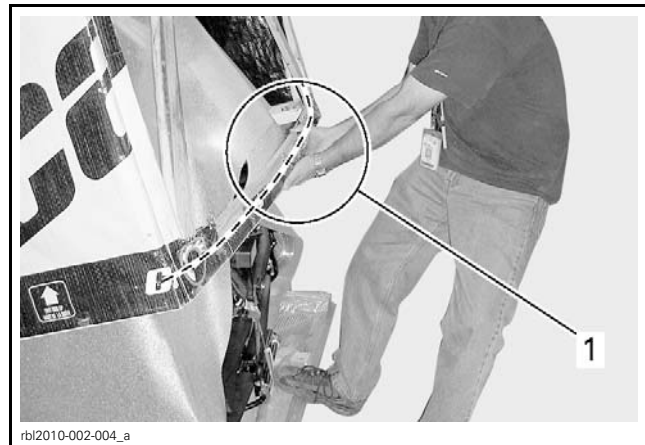

FRONT OF VEHICLE

1. Pull crate cover to clear front fascia of the vehicle

NOTICE The crate cover must be pulled toward the outside while lifting it to avoid to damage vehicle.

NOTE: Screws that are used are Robertson† #2 type (or equivalent) that require the use of an appropriate screwdriver.

Parts and Sub-crate Removal

NOTICE Be careful not to scratch the cover bumper and the front fascia.

NOTE: The sub-crate is located on the left side of vehicle and it contains the front cargo module.

1. Remove protective foam from vehicle.



2. Remove windshield and front wheels from crate base.

† Robertson is a registered trademark of Robertson Inc.

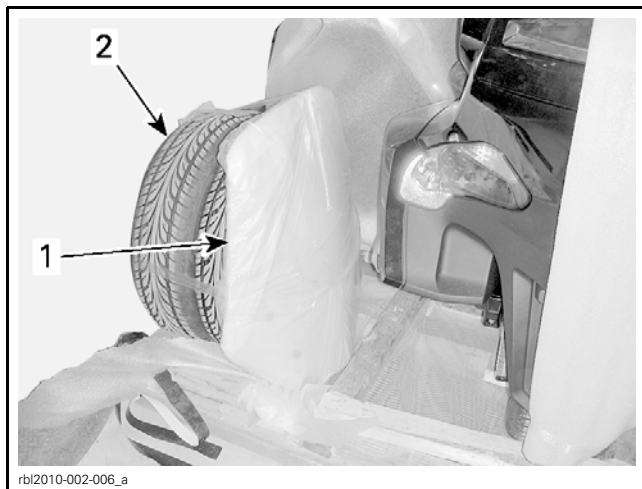

- 1. Windshield
- 2. Front wheels

3. Remove front fenders from crate base.

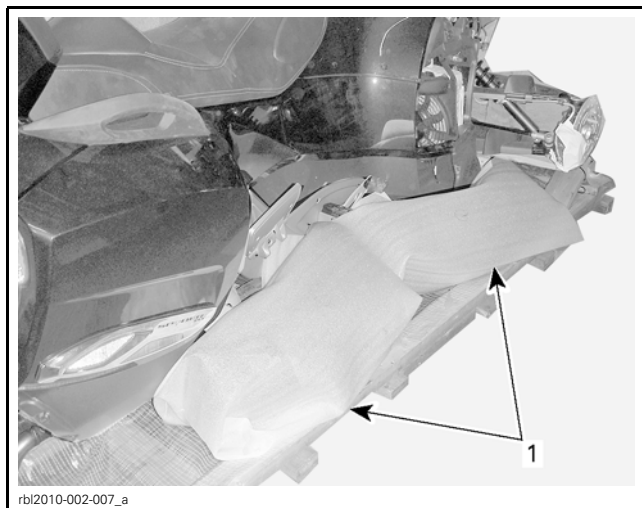

- 1. Front fenders

4. Remove all screws holding sub-crate to crate base.



- 1. Sub-crate

5. Assisted by another person, carefully lift up the sub-crate.



*NEW – Parts Check

Ensure that the crate includes the following items (inside front storage compartment) :

DESCRIPTION	MODEL	QTY
Operator's guide	All	1
Predelivery check list		1
Safety DVD		1
Predelivery kit		1
Service covers		2
Windshield trim		2
Mudguards		2
Battery protective pad		1
Wheel caps		2
Front cargo liner	RT-S RT Limited	1

The predelivery kit should included the following items:

DESCRIPTION (LOCATION)	QTY
Wheel lug nut (front wheels)	6
Plastic bushing (rear suspension)	2
M10 x 140 hexagonal flange screw (rear suspension)	1
M10 elastic flange nut (rear suspension)	1
M6 x 20 hexagonal flange screw (rear suspension)	1
M6 caged nut (front cargo module)	1

DESCRIPTION (LOCATION)	QTY
Black M6 x 20 hexagonal flange screw (front cargo module)	4
Gold M6 x 20 hexagonal flange screw (front cargo module)	2
Plastic rivet (service cover)	2
Battery installation kit (2 bolts and 2 nuts) (battery)	1
M6 x 20 Torx screw (front panels)	2
Plastic washer (front panels)	2
M14 jam nut (headlights)	2
Clip (headlights)	2
M8 x 20 hexagonal flange screw (front fenders)	8
M6 x 20 Torx screw (windshield)	4
M5 x 25 countersunk Torx screw (windshield)	2
M5 retaining nut (windshield)	2
M6 elastic flange nut (mudguards)	4
M6 x 20 Torx screw (mudguards)	4
M6 stainless steel lock washer (antenna)	1

Ensure that the following items are included inside the rear cargo compartment) :

DESCRIPTION	MODEL	QTY
iPOD+ cable	<ul style="list-style-type: none"> - RT Audio & Convenience - RT Techno - RT-S - RT Limited 	1
Audio auxiliary cable	<ul style="list-style-type: none"> - RT-S - RT Limited 	1

For the following models, remove the antenna from the sub-crate.

DESCRIPTION	MODEL	QTY
Antenna with rubber cap	<ul style="list-style-type: none"> - RT Audio & Convenience - RT Techno - RT-S - RT Limited 	1

*NEW – Lifting the Front of Vehicle

⚠ WARNING

No one should be standing in front or at the back of the vehicle while straps are being cut.

1. Remove strap retaining front of vehicle to crate base.

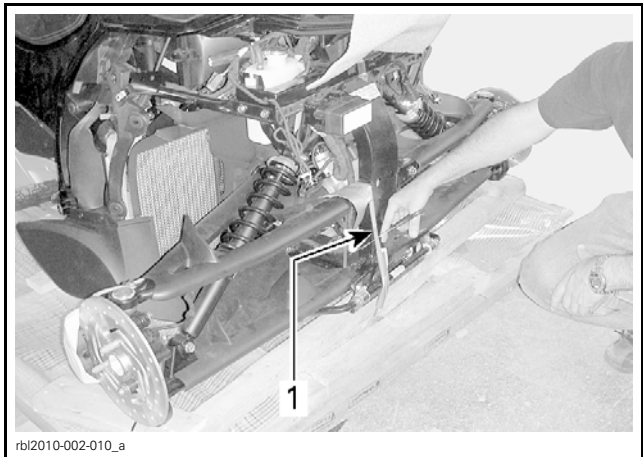

1. Front strap

2. Remove strap retaining side of vehicle to crate base.



1. Side strap

3. Remove strap on the RH caliper.

†iPod is a trademark of Apple Inc.

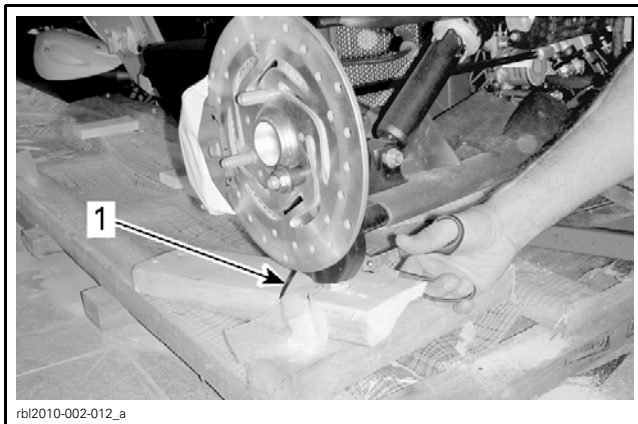

1. Caliper strap

NOTE: The following steps will describe two methods to lift the front of the vehicle. The conventional one uses a hydraulic jack and the alternate one uses a chain block. Use the proper method according to your shop layout.

Conventional Method

1. Remove top crate board located at the front of vehicle.

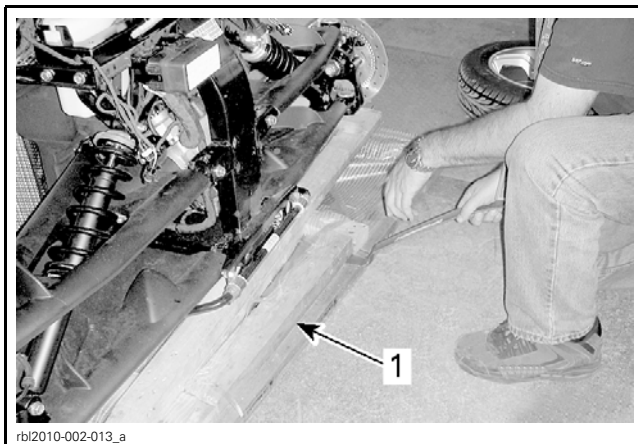

1. Stud to remove

2. Cut second crate board located at the front of vehicle using a proper saw.

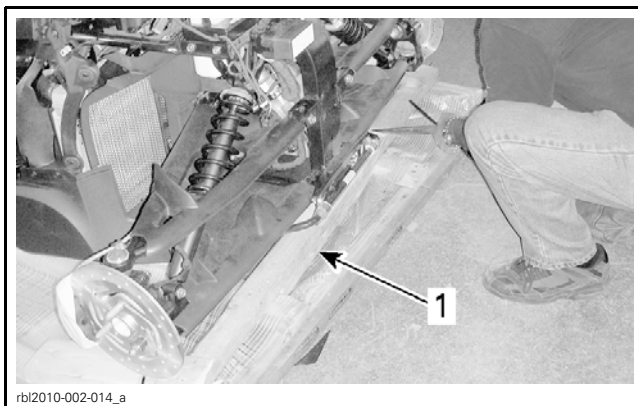

1. Stud to cut

3. Install a jack under the front lower beam of frame.

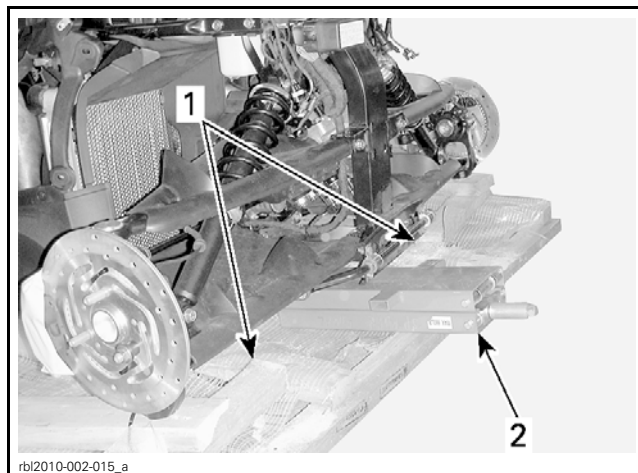

1. Stud that was cut
2. Hydraulic jack

4. Lift the vehicle.

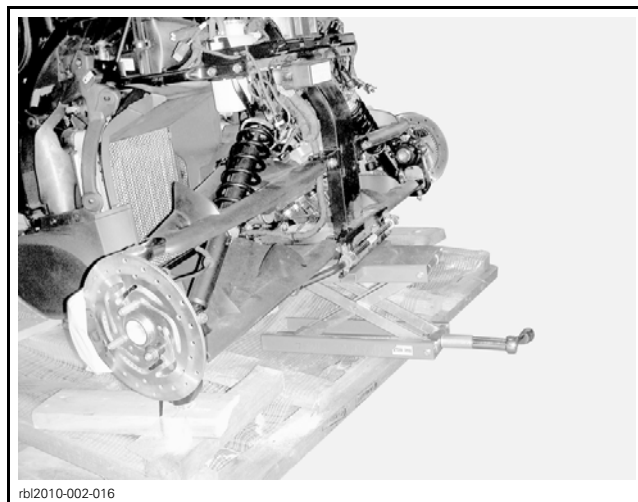

NOTICE Never lift vehicle by the suspension arm.

Alternate Method

1. Install proper straps on RH and LH lateral supports of vehicle.

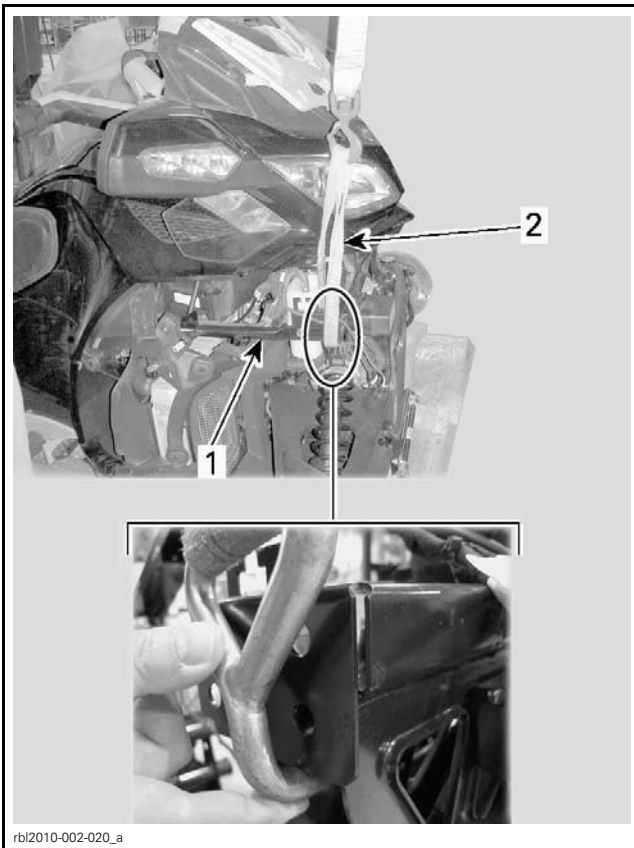

1. RH lateral support
2. Proper strap

2. Hook straps on an appropriate lifting kit.
3. Lift vehicle using a chain block.

NOTICE Never lift vehicle by the suspension arm.

*NEW – Front Wheels Installation

1. ► [Clean front and rear brake discs using XPS BRAKES AND PARTS CLEANER \(P/N 219 701 705\) and a clean rag.](#)

NOTICE [A thin layer of anticorrosion treatment is present on the brake discs and must be removed before using the vehicle. Not conforming to this procedure may lead to a brake chattering squeaking and brake pad replacement would be necessary.](#) ◀

2. Remove nut securing front brake discs to vehicle.

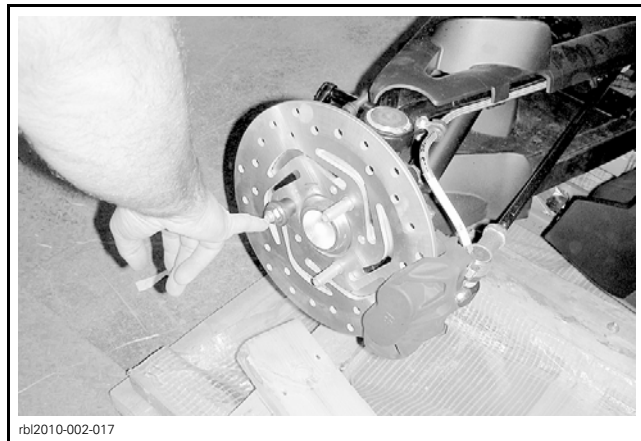

3. Install front wheels on vehicle.

NOTICE Be careful not to scratch front wheels with ball joint cotter pins during wheels installation.

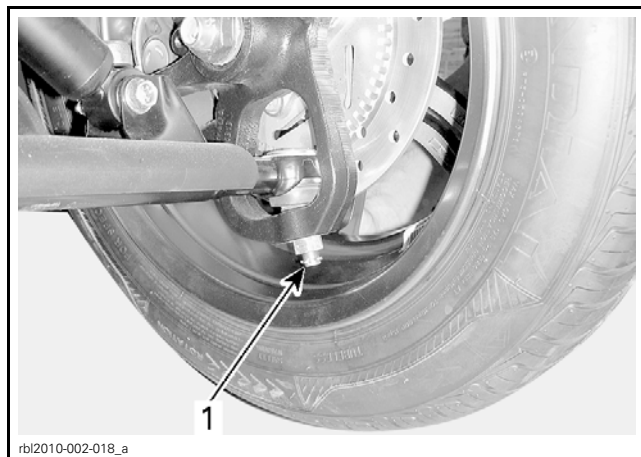

1. Ball joint cotter pin

4. Ensure that the rotation direction shown by the arrow is respected.

⚠ WARNING

The tires are only designed to rotate in one direction. Do not switch the left and right front wheels.

5. Tighten wheels lug nuts by hand (from PDI kit).
6. Lower vehicle on crate base.

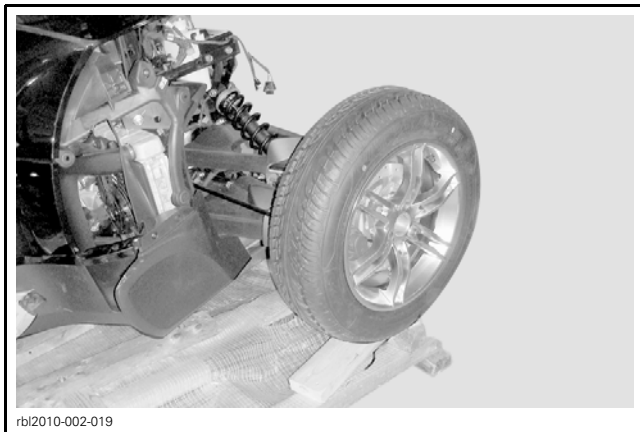

7. Torque wheels lug nuts.

PART	TORQUE
Wheel lug nut	105 N•m (77 lbf•ft)

8. Install wheel caps (inside front storage compartment).

► Tire Pressure ◀

⚠ WARNING

► Low pressure may cause tire to deflate and rotate on wheel. Overpressure may burst the tire. Always follow recommended pressure.

NOTICE Always check pressure when tires are cold before using the vehicle.

NOTE: Tire pressure changes with temperature and altitude. Recheck pressure if one of these conditions has changed (e.g., significant weather change, driving in the mountains).

1. Inflate tires to the specified air pressure. Refer to the following table.

COLD TIRE PRESSURE RECOMMENDATION	
FRONT	REAR
<u>Nominal: 103 kPa (15 PSI)</u>	<u>Nominal: 193 kPa (28 PSI) ◀</u>

*NEW – Vehicle Removal

1. Open seat.
2. Locate ACS suspension pneumatic valve then unscrew cap.

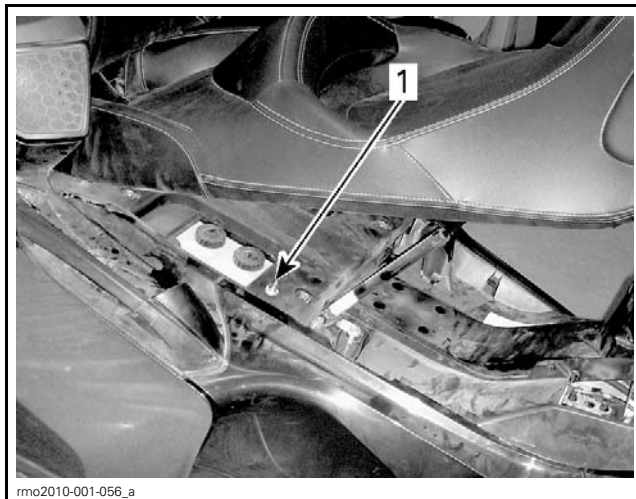

1. Pneumatic valve

3. From underneath of vehicle, locate the bottom of the rear shock absorber.

4. Get the following hardware from the PDI kit:
- M10 x 140 hexagonal flange screw
 - M10 elastic flange nut
 - Plastic bushings.

5. Install the 2 plastic bushings over the steel sleeve at the bottom of the shock absorber.

6. With the help of another person, gently inflate the ACS spring while your assistant, from the LH side of the vehicle, monitors the alignment of the bottom of the shock absorber (anchoring holes) with the bottom of the lower brackets.

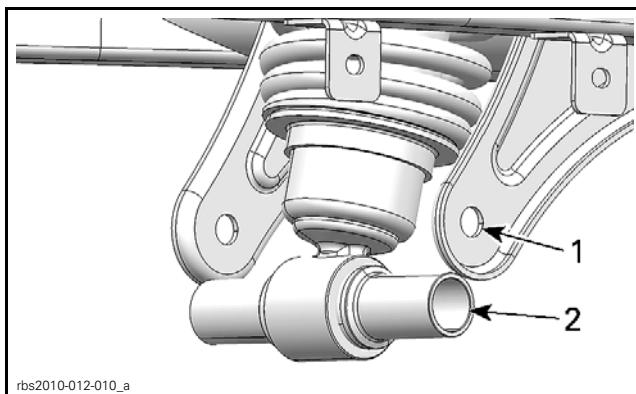

1. Lower bracket hole
2. Anchoring holes

NOTICE Adding air may create rapid high changes because of the small air volume in the ACS spring. The anchoring hole of shock absorber must NEVER exceed the lower bracket holes when adding air into ACS spring. To avoid damaging the ACS system, DO NOT exceed 551 kPa (80 PSI) into the ACS spring.

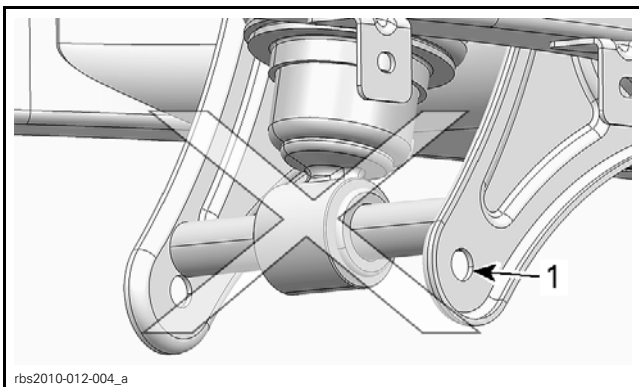

1. Lower bracket hole

7. Secure shock absorber as follows:

- 7.1 Using the passenger grab handles, slightly lift the rear of the vehicle by HAND to align both bushings on lower bracket hole.
- 7.2 Install M10 x 140 hexagonal flange screw.
- 7.3 Install and torque M10 elastic flange nut.

PART	TORQUE
M10 elastic flange nut	48 N•m (35 lbf•ft)

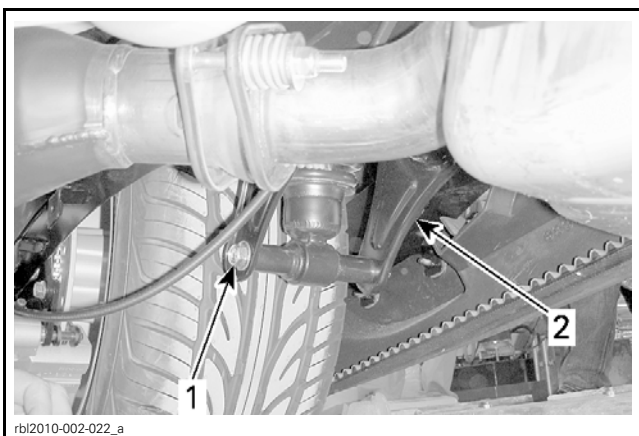

1. Shock absorber bolt
2. Lower bracket

RT-S and RT Limited Models

- 8. Install the link of the ACS position sensor to swing arm.
 - 8.1 Position the ACS position sensor lever rearward.
 - 8.2 Place the link on the outside of swing arm bracket.
 - 8.3 Secure the link using M6 x 20 hexagonal flange screw (from PDI kit)

PART	TORQUE
M6 x 20 hexagonal flange screw	4 N•m (35 lbf•in)

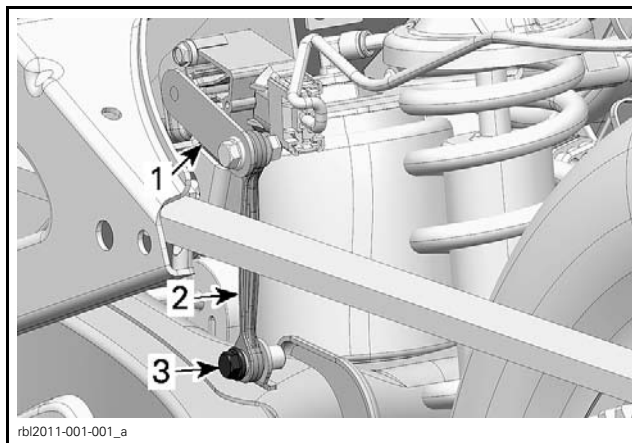

1. ACS position sensor lever
2. ACS position sensor link
3. M6 x 20 hexagonal flange screw

NOTICE Ensure that ACS position sensor lever orientation is correct.



CORRECT ORIENTATION



INCORRECT ORIENTATION

⚠ WARNING
SE5 models are automatically set in neutral position when engine is stopped. Always secure the rear wheel of vehicle with proper blocks to avoid moving.

- 9. With the help of your assistant, move vehicle rearward out of the crate base.



NOTICE Always move vehicle rearward out of the crate base.

PARTS TO BE INSTALLED

Front Cargo Module

1. Remove and discard bolts and nuts holding the bottom and the top sections of sub-crate.

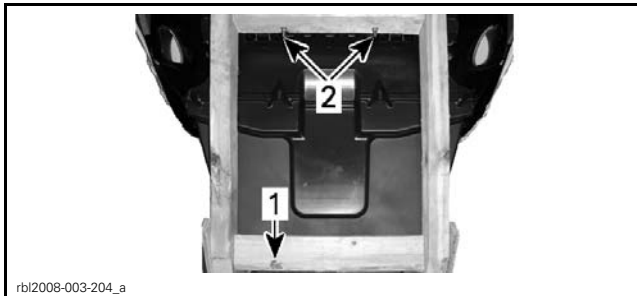

1. Bolt and nut holding the bottom section
2. Bolts and nuts holding the top section

NOTE: Be careful not to lose the caged nut located in the bottom fixation hole of the front cargo module.

2. Open front storage compartment cover.
3. Ensure that the following cables and connectors are accessible prior to installing front cargo module, cut locking ties if required.

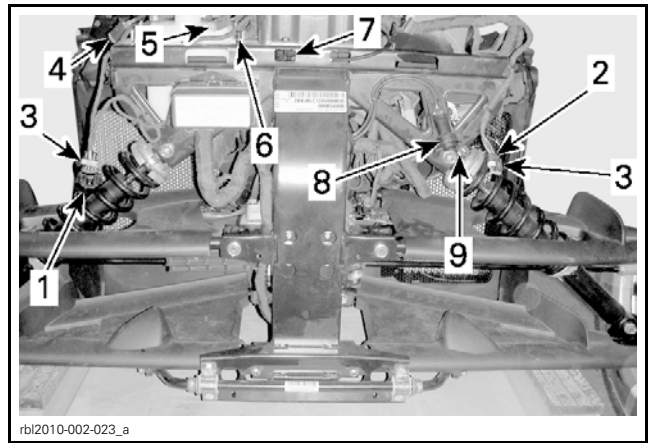

REFER TO THE FOLLOWING TABLE FOR ITEMS DESCRIPTION

ITEMS	DESCRIPTION
1	AAPTS sensor connector
2	Horn connector (hidden on the illustration)
3	RH and LH auxiliary light connector - Low beam light (CE) - Fog light (option package)
4	DLC connector (B.U.D.S.)
5	Storage cover actuator connector (option package)
6	Storage cover switch connector (option package)
7	Storage cover cable
8	12 V power outlet
9	Storage compartment light (option package)

4. Install headlight harness clip (from PDI kit) on vehicle frame as shown (on both side).



1. Headlight harness clip

5. Cut locking tie holding headlight harness.

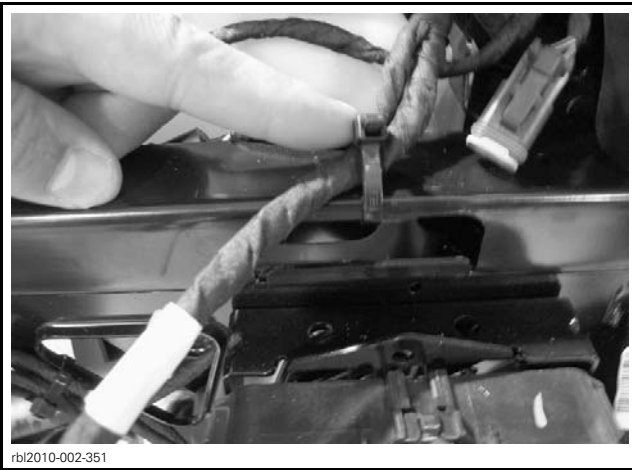

rbl2010-002-351

6. Insert headlight harness into clips as shown.



rbl2010-002-352

LH SIDE



rbl2010-002-353

RH SIDE

7. Do not let auxiliary lights harness hang near shock absorber. Properly insert it into clips (on both sides).



rbl2010-002-354

CORRECT INSTALLATION



rbl2010-002-355_a

WRONG INSTALLATION

8. Remove mirrors as follows:

- 8.1 Pull lower part of mirror toward the outside to unlock it.
- 8.2 Slide mirror upwards to unhook it from upper slot.
- 8.3 Disconnect connector.

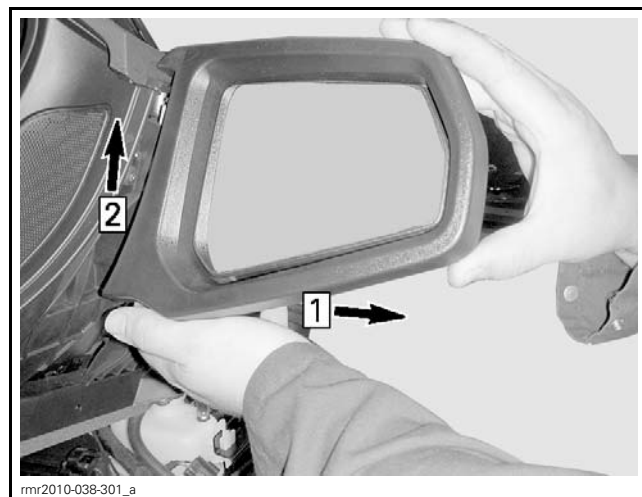

Step 1: Pull toward the outside
Step 2: Slide upwards

9. Remove middle side panels as follows:

9.1 Pull panel toward the outside to remove it from grommets at the front.

9.2 Unhook the rear.

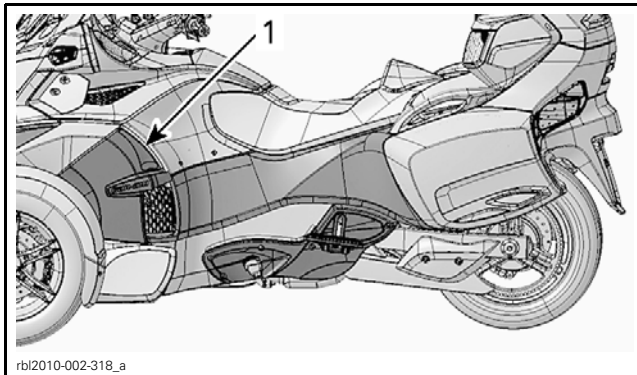

TYPICAL

1. Middle side panel

10. Remove retaining screws from lower wind deflectors.

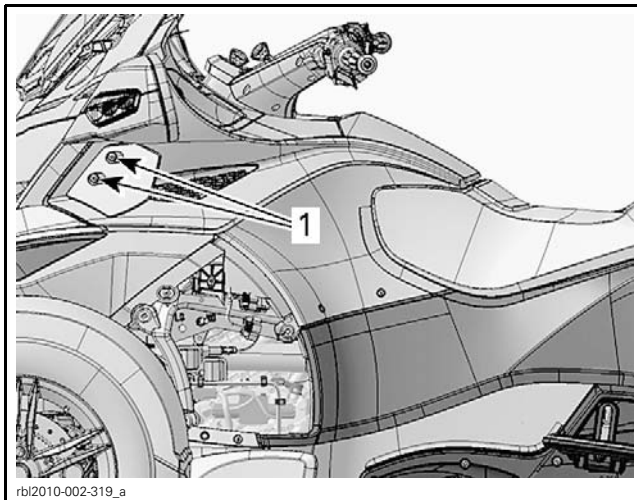

TYPICAL

1. Retaining screws of wind deflector

11. Remove upper retaining screws from top side panels.

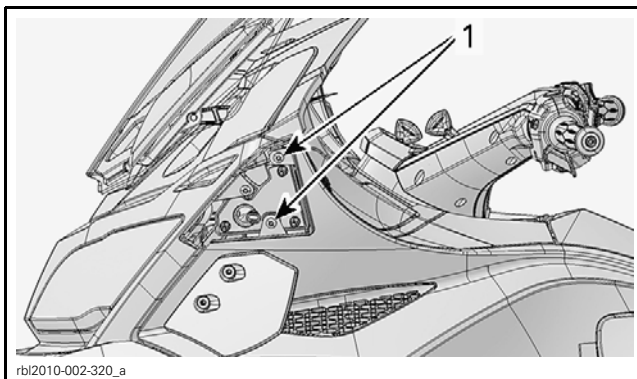

TYPICAL

1. Upper retaining screws

12. Remove rear retaining screw from top side panels.

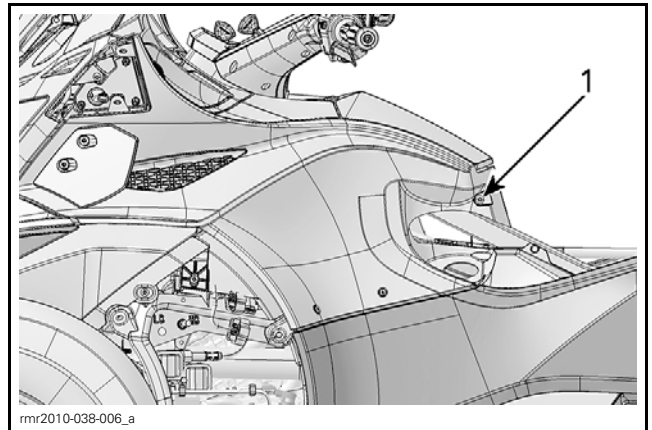

TYPICAL

1. Rear retaining screw

13. Remove front retaining screw from top side panels.

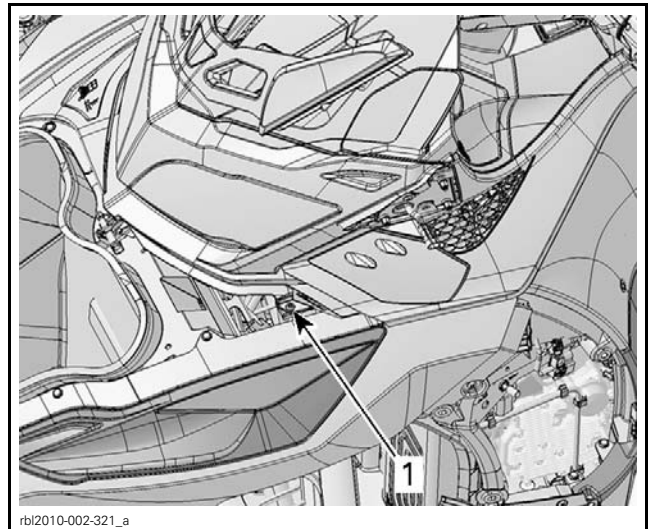

TYPICAL

1. Front retaining screw

14. Pull out lower part of top side panel to remove it from grommets.

NOTE: Do not remove lower screws from top side panel.



15. Remove top side panels by lifting them upwards.

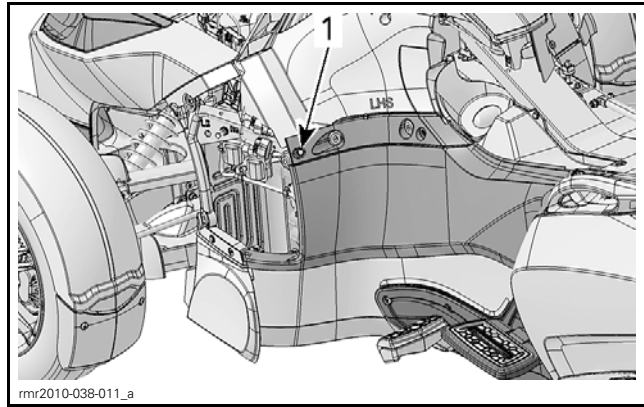

1. Front plastic rivet

19. Open LH storage compartment cover.

20. Remove rear retaining screws from LH rear side panel.

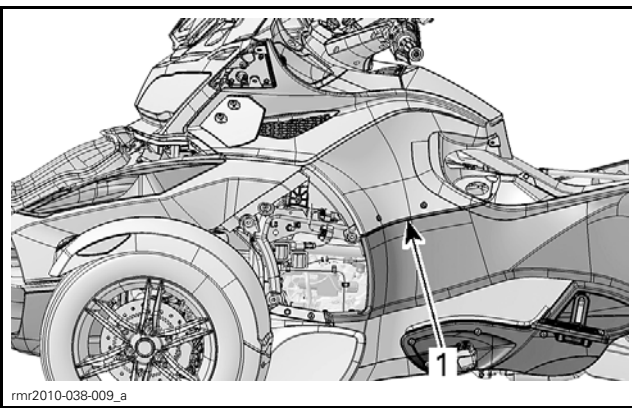

TYPICAL

1. Top side panel

16. Remove front retaining screw of LH rear side panel.

17. Remove upper retaining screw and washer from LH rear side panel.

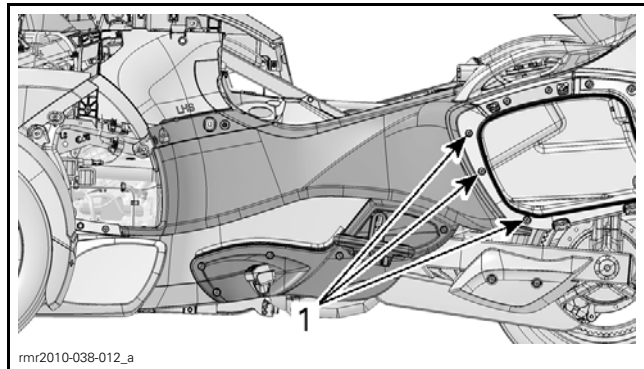

1. Rear retaining screws

21. Remove top retaining screw of LH rear side panel.

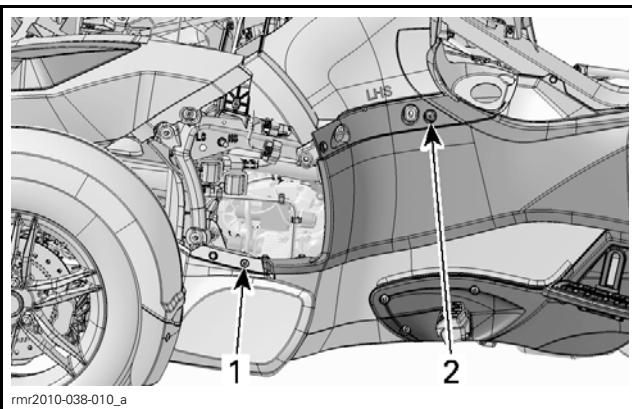

1. Front retaining screw
2. Upper retaining screw

18. Remove front plastic rivet from LH rear side panel.

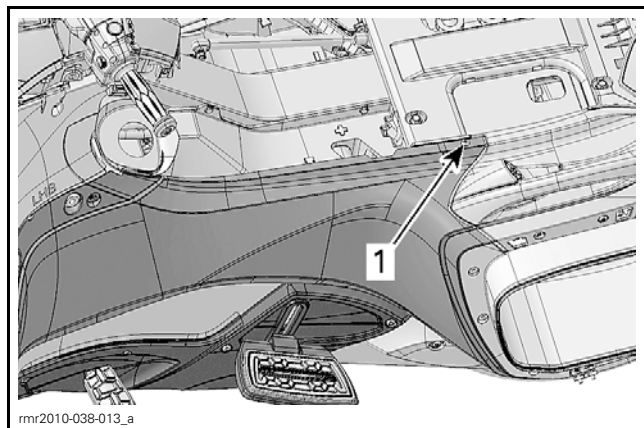

1. Top retaining screw

NOTICE Be careful not to break lower tabs.

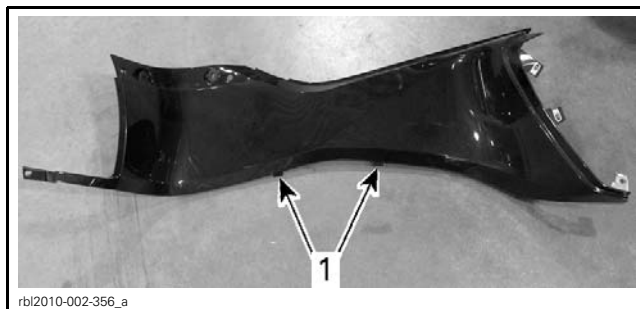

LH REAR SIDE PANEL

1. Lower tabs

22. Remove LH rear side panel from vehicle.
23. Remove upper retaining screws from front fascia.

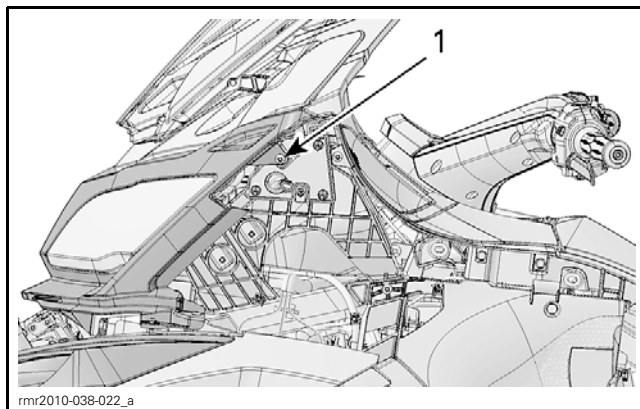

TYPICAL

1. Upper retaining screw

24. Remove middle retaining screws from front fascia.



TYPICAL

1. Middle retaining screw

25. Remove lower retaining screws and washers from front fascia.

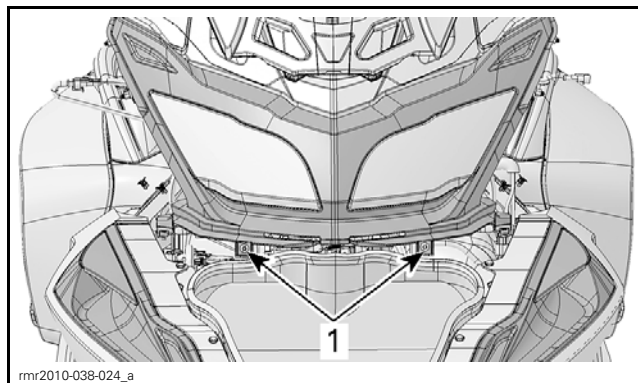

TYPICAL

1. Lower retaining screw

26. Remove front fascia from vehicle.
27. Use the following hardware to fix front cargo module on vehicle.

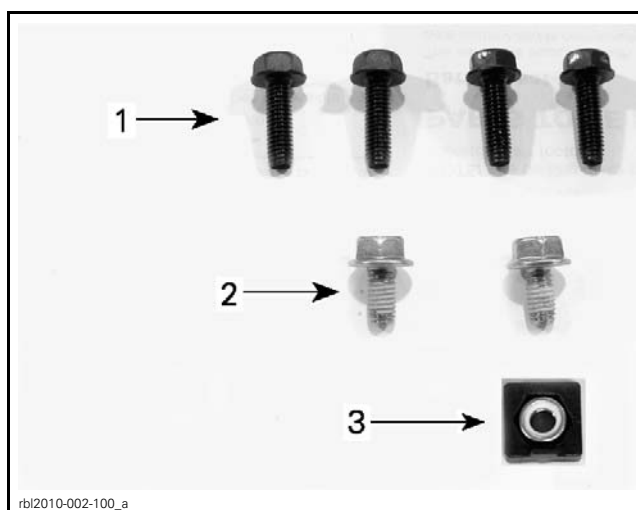

1. Black M6 x 20 hexagonal flange screws from PDI kit
2. Gold M6 x 20 hexagonal flange screws from PDI kit
3. M6 caged nut from PDI kit

NOTE: The second caged nut is already installed on front cargo module.

28. Assisted by another person, position front cargo module into support slots of vehicle.
29. Connect the following front cargo module connectors and cable:
 - APTS sensor connector
 - Horn connector
 - RH and LH auxiliary light connector (CE and Option Package)
 - DLC connector (B.U.D.S.) stowed in its receptacle
 - Storage cover actuator connector (option package)
 - Storage cover switch connector (option package)
 - Storage cover cable

PARTS TO BE INSTALLED

- 12 V power outlet
- Storage compartment light (option package).

CE Models

30. Install auxiliary light adjustment cable as follows:

- 30.1 Install adjustment cable through hole in panel.
- 30.2 Tighten nut securing adjustment cable (from PDI kit).

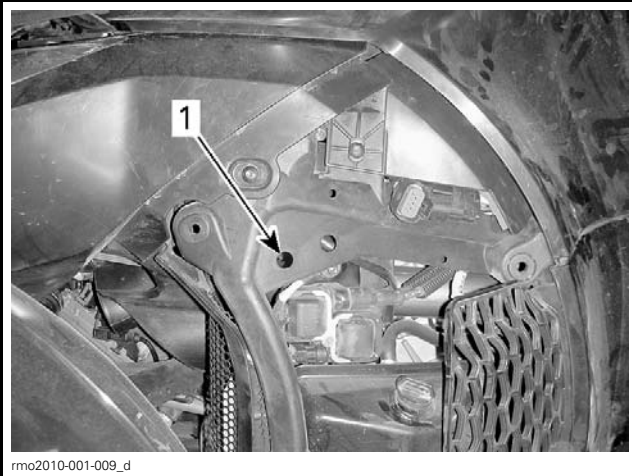

LEFT SIDE SHOWN
1. Install through this hole

All Models

31. Install M6 caged nut (from PDI kit) on a bottom hole of storage compartment.
32. Install gold M6 hexagonal flange screws to secure bottom of storage compartment. Do not tighten yet.

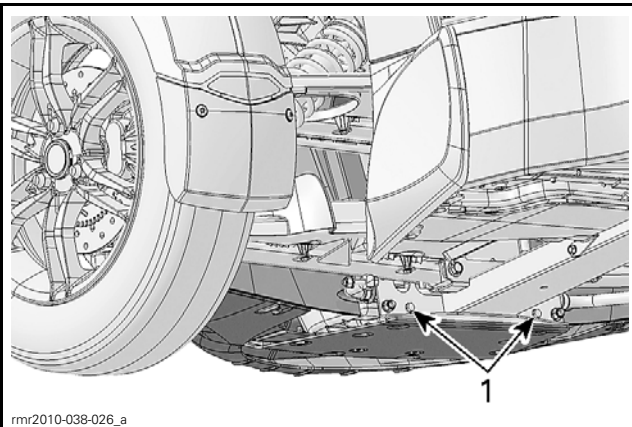

1. Gold M6 screws

33. Install black M6 hexagonal flange screws to secure top of storage compartment.

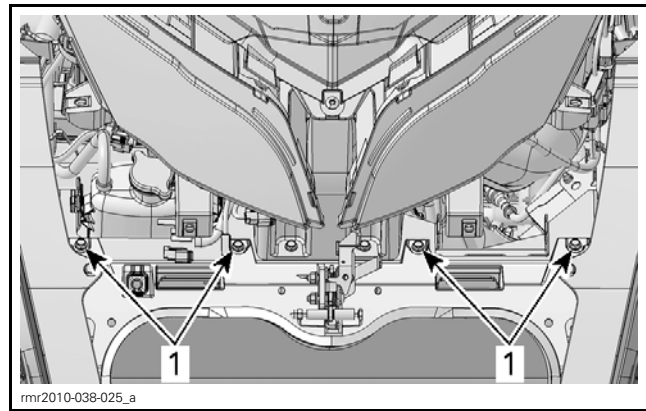

1. Black M6 screws

34. Torque upper and lower M6 hexagonal flange screws.

PART	TORQUE
M6 hexagonal flange screws	4.5 N•m (40 lbf•in)

35. Do not reinstall body panels for the moment, follow *BATTERY CHARGING AND INSTALLATION* procedure then finalize front cargo module as per *FRONT CARGO MODULE (CONTINUED)* procedure.

*NEW – Battery Charging and Installation

NOTE: The battery is filled and serviced. However it needs to be fully charged prior to vehicle delivery. To perform charging of the battery you will need to remove battery from vehicle.

NOTE: Refer to the latest edition of *CAN-AM ROADSTER BATTERIES SERVICE BULLETIN* for proper activating, charging and maintenance procedures.

1. Open seat
2. Disconnect cylinder from seat base.

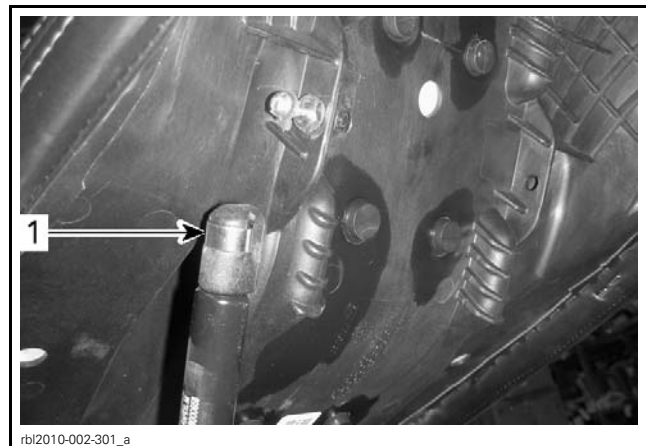

1. Cylinder

3. Lift seat and secure it using a piece of wood.



4. Unplug pillion rider (passenger) switch.

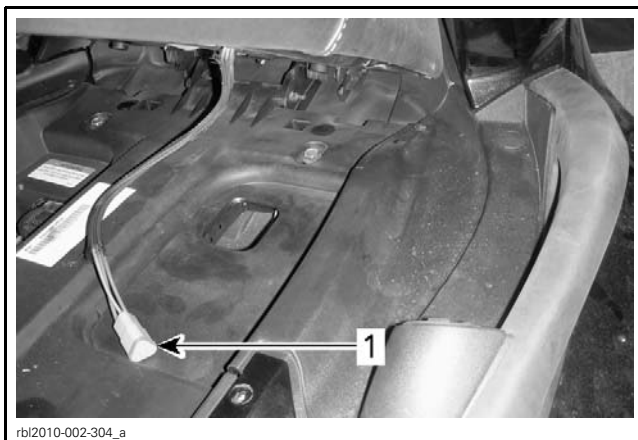

1. Pillion rider switch connector

5. Remove the battery access panel located at the LH side of vehicle.

6. Disconnect rear heated grip switch if applicable.

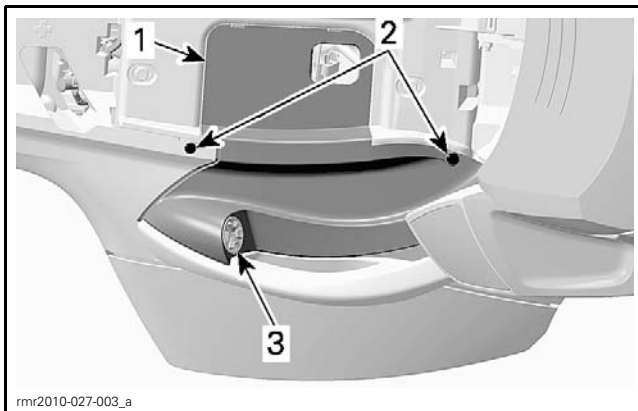

TYPICAL - LH SIDE OF VEHICLE

1. Battery access panel
2. Battery access panel retaining screws
3. Rear heated grips switch

7. Remove battery holding strap and discard battery hardware included with the battery.

8. Cut locking ties securing battery cables together.

9. Move electrical harness outward to make room around battery.



10. Lift the leading edge of the battery and carefully pull it out of the battery rack.

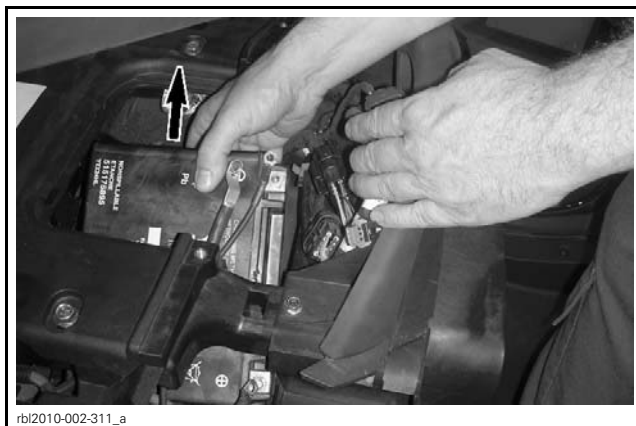

11. Charge battery. Refer to *CAN-AM ROADSTER BATTERIES SERVICE BULLETIN*.

CAUTION Never charge or boost battery while installed on vehicle.

NOTICE It is of the utmost importance for the battery life span that the battery initial charging be performed.

12. Install charged battery in battery rack.

NOTICE Always charge battery before its installation on the vehicle.

13. Connect RED (+) positive battery cables using battery screws from the PDI kit.

WARNING

Always connect RED (+) cable first.

14. Tighten positive post battery screw.

PARTS TO BE INSTALLED

PART	TORQUE
Post battery screw	4 N•m (35 lbf•in)

15. Apply DIELECTRIC GREASE (P/N 293 550 004) on battery posts.

16. Close RED rubber boot cover.



rbl2010-002-032

17. Connect BLACK (-) negative battery cables as shown:

17.1 Position BLACK (-) main battery cable (large) on negative (-) battery post.

17.2 Position BLACK (-) regulator/rectifier cable (small) on negative (-) battery post.

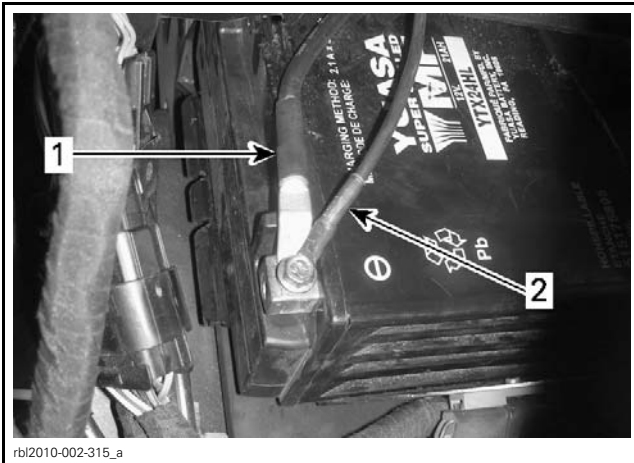

rbl2010-002-315_a

1. BLACK (-) main battery cable (large)
2. BLACK (-) regulator/rectifier cable (small)

17.3 Tighten negative post battery screw.

PART	TORQUE
Post battery screw	4 N•m (35 lbf•in)

18. Fold the protective pad and secure the locking tab using the dart.

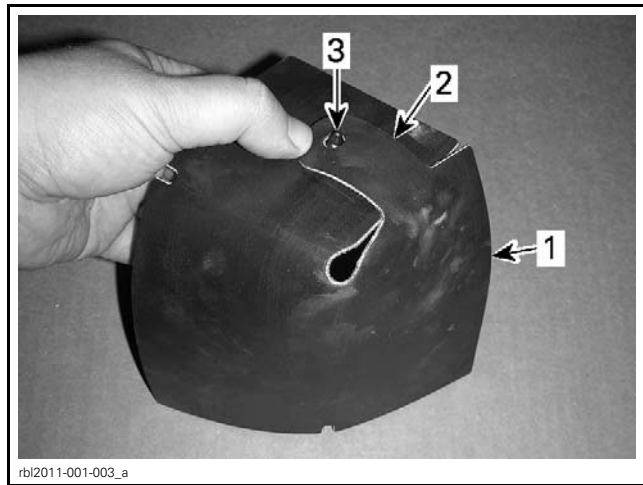

rbl2011-001-003_a

1. Protective pad
2. Locking tab
3. Dart

19. Install the protective pad over the visible battery corner as shown on the following illustration.

20. Install battery holding strap.

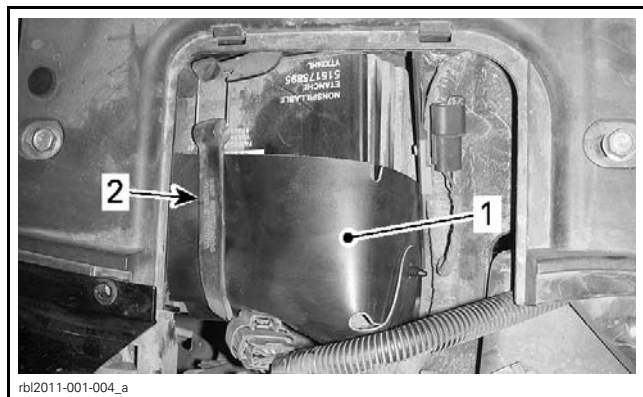

rbl2011-001-004_a

1. Protective pad
2. Battery holding strap

NOTICE Make sure not to squeeze battery cables between vehicle components.

21. Position electrical harness in their original location.

22. Connect rear heated grip switch if applicable.

23. Install the battery access panel.

24. Connect pillion rider (passenger) switch.

25. Connect shock absorber on seat base.

Front Cargo Module (continued)

1. Install the following body panels as the reverse of removal procedure:

- Front fascia
- LH rear side panel
- Top side panels

- Middle side panels
 - Mirrors.
2. Install M6 x 20 Torx screws and plastic washers (from PDI kit) to secure side panels.

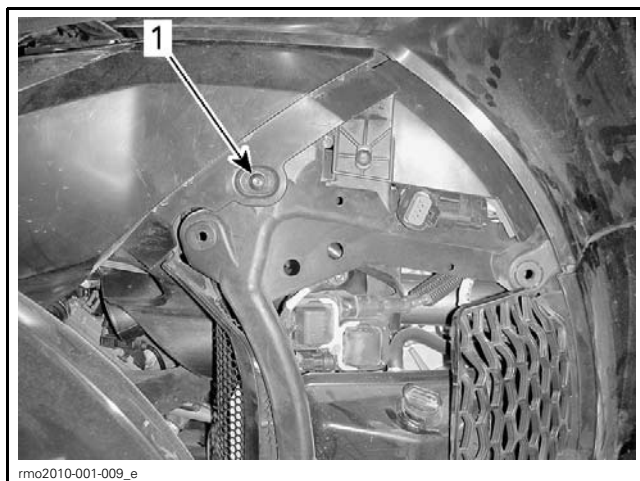

rmo2010-001-009_e

LEFT SIDE SHOWN

1. M6 x 20 Torx screw and plastic washer (from PDI kit)

3. Torque front fascia retaining screws and top side panels retaining screws.

PART	TORQUE
M6 x 20 Torx screw	3.5 N•m (31 lbf•in)

4. Install service covers as follows:

- 4.1 Open front storage compartment cover.
- 4.2 Insert upper tabs of service cover into the vehicle grooves.
- 4.3 Push lower portion of service cover then install plastic rivet (from PDI kit).

NOTICE For the RH service cover, pay attention not to damage the FCS switch.

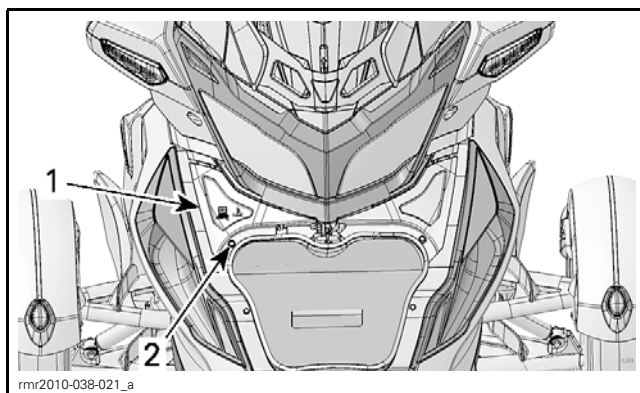

rmr2010-038-021_a

1. RH service cover
2. Plastic rivet

Mudguards

1. From inside mudguards, check for proper location (LH or RH side).



rbl2010-002-029_a

1. Installation side

2. Install two M6 panel nuts (from PDI kit) on each fender.

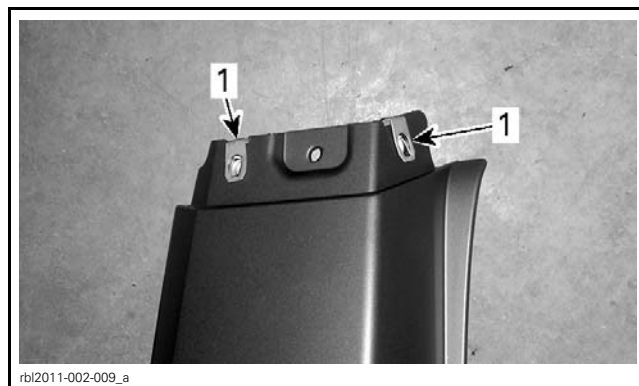

rbl2011-002-009_a

1. Panel nuts

3. Position mudguards on proper fender.
4. Secure mudguards using M6 x 20 Torx screws (from PDI kit).

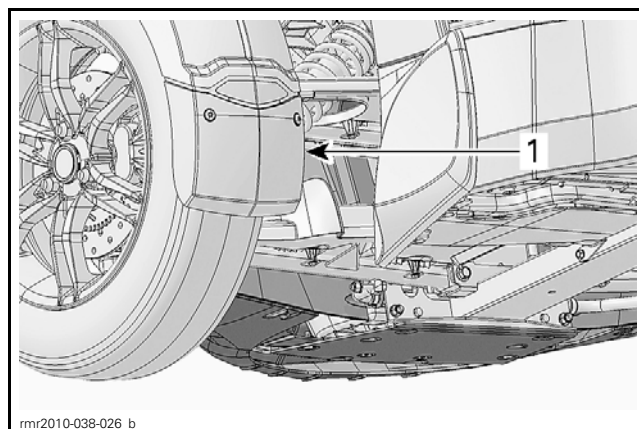

rmr2010-038-026_b

1. Mudguard

MUDGUARD SCREW TIGHTENING TORQUE

3 N•m (27 lbf•in)

Front Fenders

1. Cut locking tie that hold harness bracket on fender.

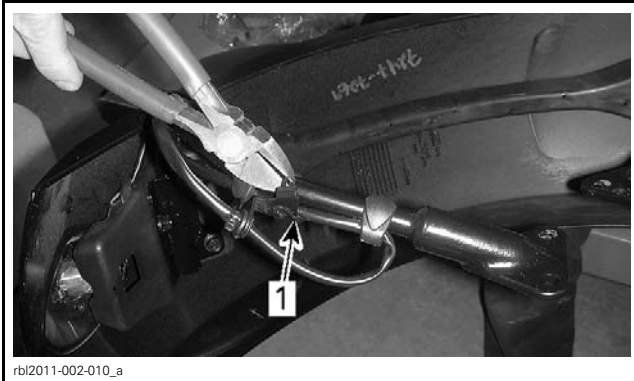

1. Locking tie

2. Position front fender on vehicle.



3. Route front brake hose on fender hook.

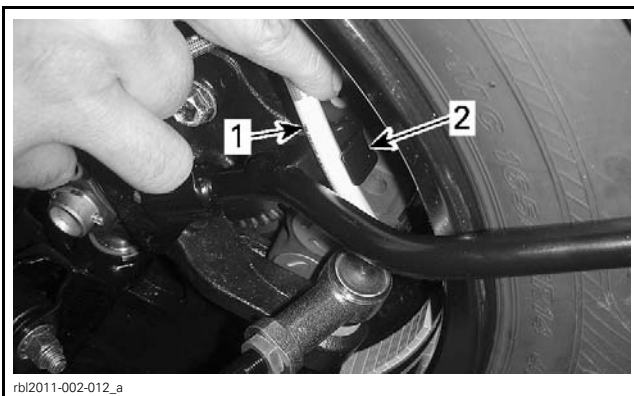

1. Brake hose
2. Fender hook

4. Properly insert cable grommet on harness bracket.

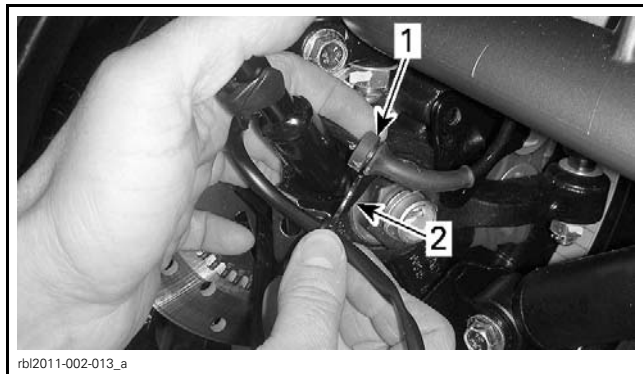

1. Cable grommet
2. Harness bracket

5. Connect fender light connector.

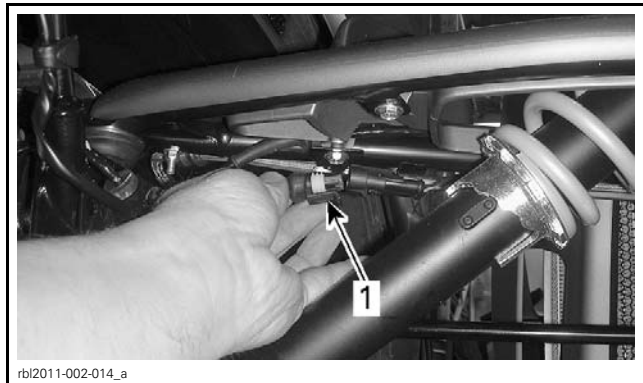

1. Fender light connector

6. Secure fender support on wheel hub.

- 6.1 Install the harness bracket over the fender support and secure them on wheel hub using a M8 x 35 hexagonal flange screw and a sleeve from the PDI kit.

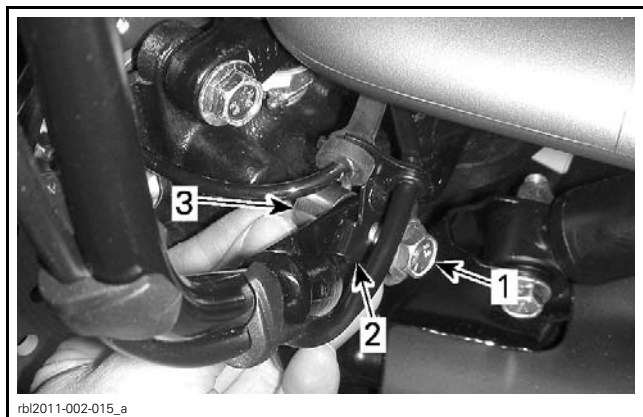

1. M8 x 35 hexagonal flange screws
2. Sleeves (one hidden)
3. Harness bracket

- 6.2 Install 3 other M8x 35 hexagonal flange screws and sleeves to complete the fender support installation.

FENDER SUPPORT RETAINING SCREW

24 N•m (18 lbf•ft)

7. Carry out the same procedure for the other side.

Windshield

1. Align windshield on windshield support.
2. Install M6 x 20 Torx screws (from PDI kit) to secure windshield.

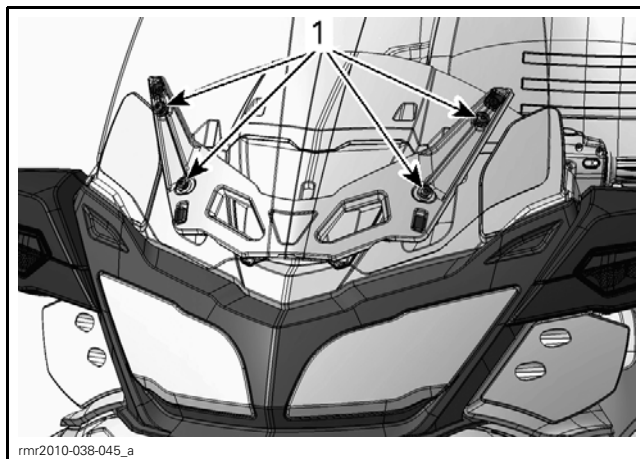

1. Windshield M6 x 20 screws

3. Torque windshield retaining screws.

PART	TORQUE
Windshield retaining screw	4.5 N•m (40 lbf•in)

4. Place a sheet of paper on windshield to protect it, refer to illustration.

NOTICE If this precaution is not taken, scratch on the windshield may occur and will not be covered under warranty.



5. Install windshield trim panels as follows:
 - 5.1 Insert M5 retaining nut (from PDI kit) on trim panel.
 - 5.2 Insert trim panel into windshield slot.

- 5.3 Push trim panel upwards.
- 5.4 From inside windshield, secure trim panel using M5 x 25 countersunk Torx screw (from PDI kit).

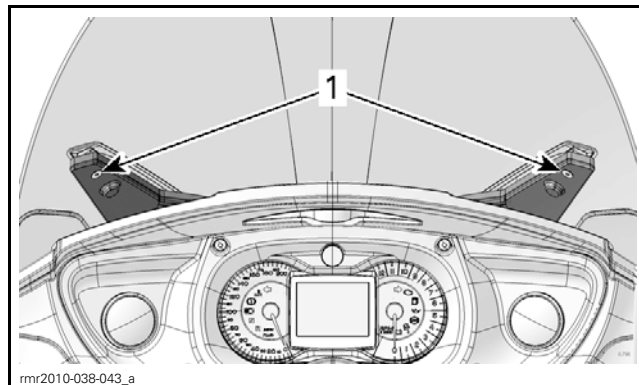

1. Windshield trim panels screws

- 5.5 Torque windshield trim panel screws.

PART	TORQUE
Windshield trim panel screw	2.5 N•m (22 lbf•in)

6. Remove sheet of paper.

*NEW – Antenna (Option Package)

All except RT STD Models

1. Detach antenna from the sub-crate.

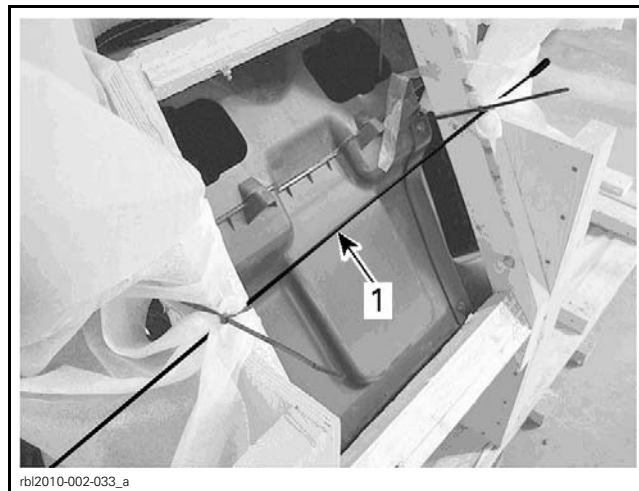

1. Antenna

Antenna Without Self-Locking Product

2. Insert the M6 stainless steel lock washer (from PDI kit) and rubber cap onto antenna.
3. Apply one drop of LOCTITE 243 (BLUE) (P/N 293 800 060) on the first thread of the antenna.

NOTICE To avoid hydro-lock or further loosening problems, do not add the threadlocker in other location and do not apply more than the recommended quantity of threadlocker.

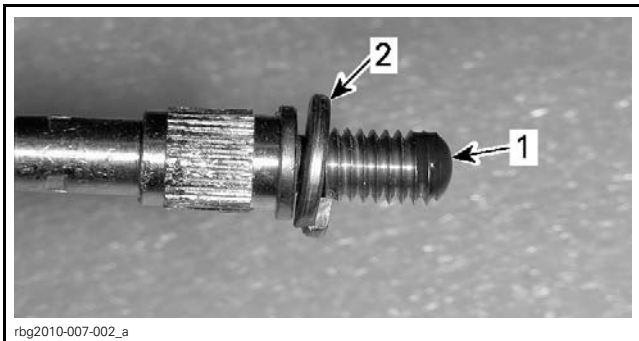

1. Drop of LOCTITE 243
2. M6 stainless steel lock washer

4. Position antenna on RH side of rear cargo module.

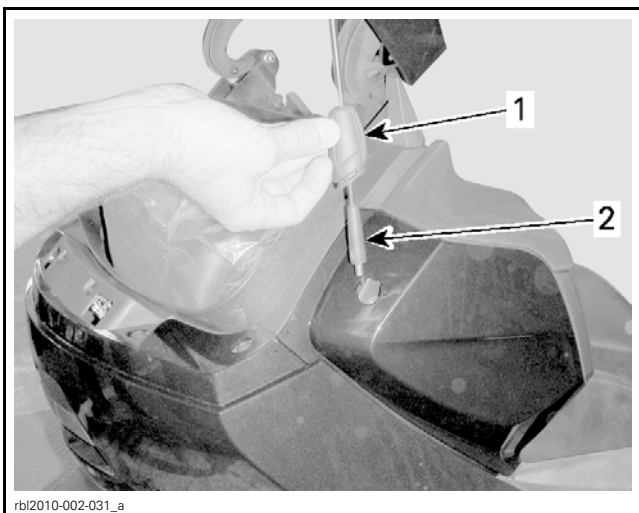

1. Rubber cap
2. Antenna

5. Tighten antenna then install rubber cap on vehicle (tighten by hand).

Antenna With Self-Locking Product

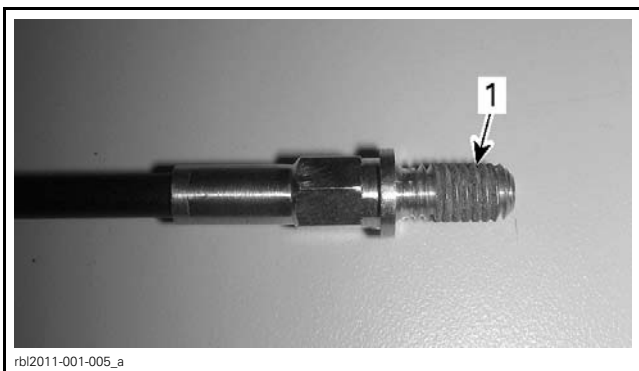

1. Self-locking product already applied

Install the antenna on the RH side of the rear cargo module (tighten by hand) and position the rubber cap.

Hang Tag and Safety Labels

This vehicle comes with a hang tag and labels containing important safety information. The labels are considered permanent parts of the vehicle and should not be removed. Hang tag is to be removed by the owner only.

Any person who rides this vehicle should read and understand all the information given on hang tag and safety labels before riding.

Safety labels of several language can be chosen by customer, according to availability.

<p>▲ WARNING</p> <p>The Spyder roadster is a different type of vehicle - it requires special skills and knowledge. Learn how the Spyder roadster is different.</p> <p>Read the operator's guide (in the front storage compartment) and watch the safety video.</p> <p>Complete a training course (if available), practice, become proficient with the controls, and get a proper license. Refer to the Safety Card before riding.</p> <p>Always wear a helmet and riding gear. With this type of vehicle, riders are exposed to more road risks than in a car. Even skilled operators can be struck by other vehicles or lose control. This vehicle will not protect you in a crash.</p> <p>Handling limits and road conditions The Vehicle Stability System (VSS) cannot stop you from losing control, flipping over, or falling off if you exceed this vehicle's limits. Know the limits for different road conditions. Do not ride on ice, snow, or off road. Avoid puddles and running water. This type of vehicle can hydroplane on water and slip on gravel, dirt and sand covered roads. If you must go through these road conditions, slow down.</p> <p>This hangtag may only be removed by the customer.</p> <p style="text-align: right;">704901502C</p>	<p>▲ AVERTISSEMENT</p> <p>Le roadster Spyder est un véhicule différent - sa conduite exige des habiletés et des connaissances particulières. Apprenez comment le roadster Spyder diffère des autres véhicules.</p> <p>Lisez le guide du conducteur (dans le compartiment de rangement avant) et visionnez la vidéo de sécurité.</p> <p>Suivez une formation (si disponible), exercez-vous, apprenez à maîtriser les commandes et obtenez le permis approprié. Consultez la carte de sécurité avant de conduire le véhicule.</p> <p>Portez toujours un casque et des vêtements appropriés. Sur ce type de véhicule, les utilisateurs sont exposés à davantage de risques routiers qu'en automobile. Même un conducteur habile peut être frappé par un autre véhicule ou perdre le contrôle. Ce véhicule ne vous protégera pas en cas de collision.</p> <p>Limites de manoeuvrabilité et conditions routières Le système de stabilité du véhicule (VSS) ne peut pas vous empêcher de perdre le contrôle, de faire des tonneaux ou de tomber si vous dépassez les limites du véhicule. Apprenez à connaître ces limites dans différentes conditions routières. Ne conduisez pas sur la glace, sur la neige ou hors route. Évitez les flaques et les ruissellements d'eau. Ce type de véhicule peut faire de l'aquaplanage sur les chaussées détrempées et dérapier sur les routes recouvertes de gravier, de terre ou de sable. Si vous devez conduire dans ces conditions, ralentissez.</p> <p>Seul le client doit enlever cette étiquette.</p> <p style="text-align: right;">704901502C</p>
---	---

rmo2008-001-102

Licence Plate

NOTE: When a license plate needs to be installed or replaced, ensure to install new damping pad (P/N 293 740 028).

1. Remove existing plate on vehicle (if applicable).
2. Peel off backing of new damping pad.

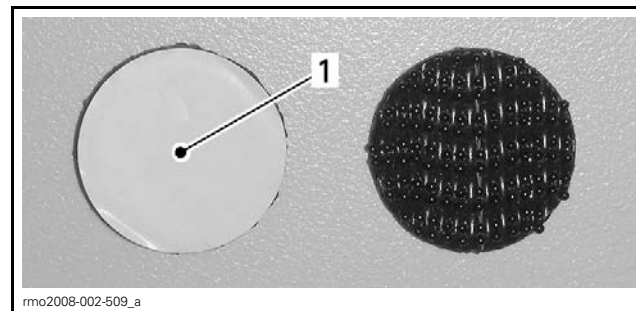

1. Damping pad backing

3. Position new damping pad on vehicle plate support.

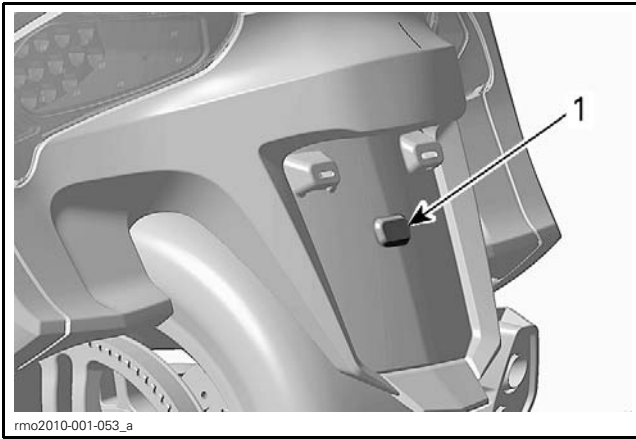

1. Plate support

- Secure upper portion of license plate on vehicle plate support using existing hardware.

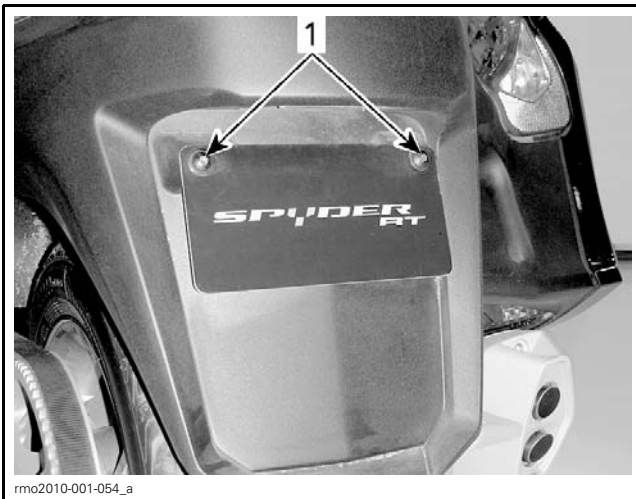

1. Existing hardware

- Squeeze license plate and support together at the center.

Accessories Installation

- Install accessories (if any) as per their installation instructions (included in each kit).
- Install any other equipment required by law (if any).

Vehicle Decals

- Install decals on vehicle according to customer country language and local legislation.
- Ensure that the new decals are installed at the same location and over the factory installed decals.

Key Barrel - Trailer RT 622

An extra key barrel is supplied with each Spyder RT. This allows the use of the vehicle key for the trailer.

Refer to the trailer RT 622 PDI Bulletin for all the details.

FLUIDS

General Guidelines

All fluids (except fuel) have already been filled at factory, it is only necessary to validate them. However, if refill is needed, refer to the appropriate *ROADSTER SHOP MANUAL* for the proper procedure.

Fuel

- Unlatch and lift seat.
- Add fuel in the fuel reservoir.

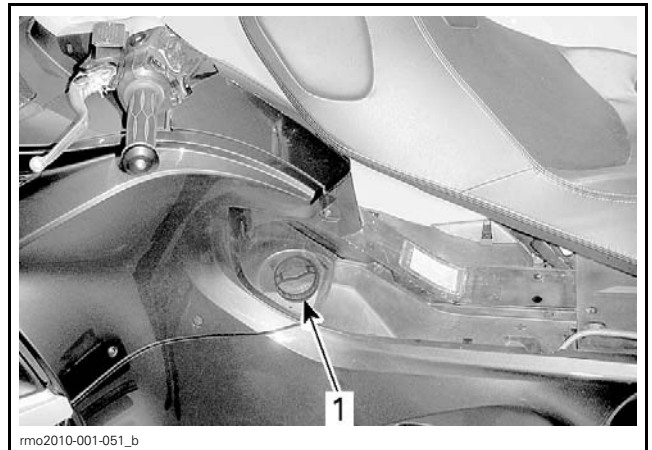

1. Fuel cap

Recommended Fuel

Use unleaded gasoline or oxygenated fuel containing no more than 10% ethanol or methanol. The gasoline used must meet the following octane number:

FUEL OCTANE RATING	
INSIDE NORTH AMERICA	
Recommended	Minimum
91 (RON + MON)/2	87 (RON + MON)/2
Use premium unleaded fuel for optimum engine performance.	

FUEL OCTANE RATING	
OUTSIDE NORTH AMERICA	
Recommended	Minimum
95 RON	92 RON
Use premium unleaded fuel for optimum engine performance.	

⚠ WARNING
 Never top off the fuel tank before placing the vehicle in a warm area. As temperature increases, fuel expands and may overflow. Fuel is flammable and explosive under certain conditions. Always wipe off any fuel or oil spillage from the vehicle.

NOTICE Other fuel can degrade vehicle performance and damage critical parts in the fuel system and engine.

Engine Oil

NOTICE The procedures for checking the Spyder roadster oil level and replacing oil are different from most of the motor vehicles today. Properly follow instructions provided in this section.

Recommended Engine Oil

The following parts are lubricated with the same oil:

- Engine
- Gearbox
- Clutch
- Hydraulic Control Module (SE5 Models only)

Use XPS SYNTHETIC BLEND OIL (SUMMER GRADE) (P/N 293 600 121).

If not available, use a 5W 40 semi-synthetic (minimum) or synthetic **motorcycle oil** meeting the requirements for API service SL, SJ, SH or SG classification. Always check the API service label on the oil container.

NOTICE To avoid damaging the clutch, do not use a motor oil meeting the API service SM or ILSAC GF-4 classification. Clutch slippage will occur. Motorcycle oils designed for use with a wet-clutch are the best alternative.

Engine Oil Level Verification

⚠ WARNING
 Before starting vehicle ensure vehicle in a well ventilated area or is outside. Smoke will come from the engine for 10 minutes as the anti corrosion coating on the exhaust system and engine burns off.

NOTICE For an accurate oil level reading, it is necessary to ride vehicle for 5–7 minutes to ensure that the engine is at its operating temperature. If oil level is verified when vehicle is not at operating temperature, oil level must be between lower and upper marks on dipstick.

NOTICE Never add oil in the engine if the verification is performed when the engine is cold.

1. Park the vehicle on a level surface.
2. Remove the LH middle side panel as follows:
 - 2.1 Pull panel out of its grommets at the front then unhook the rear.

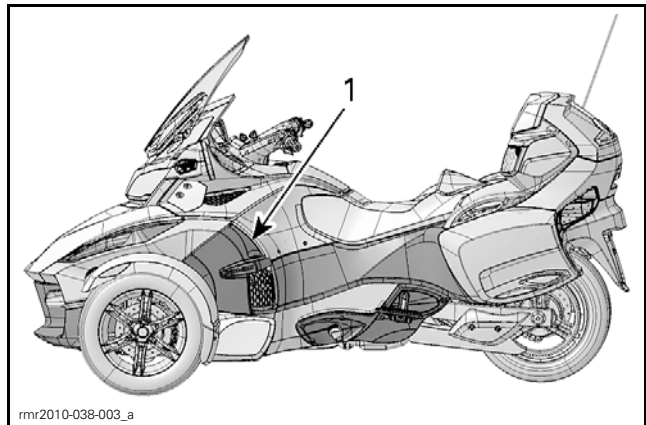

1. Middle side panel

3. With the engine already at normal operating temperature, start engine and let it run for at least 30 seconds.

NOTE: Running engine for at least 30 seconds allows the suction oil pump to drain the oil from the engine crankcase back into the oil tank. Not carrying out this step could result in overfilling the engine oil.

4. Stop engine.
5. Unscrew and remove the oil dipstick.

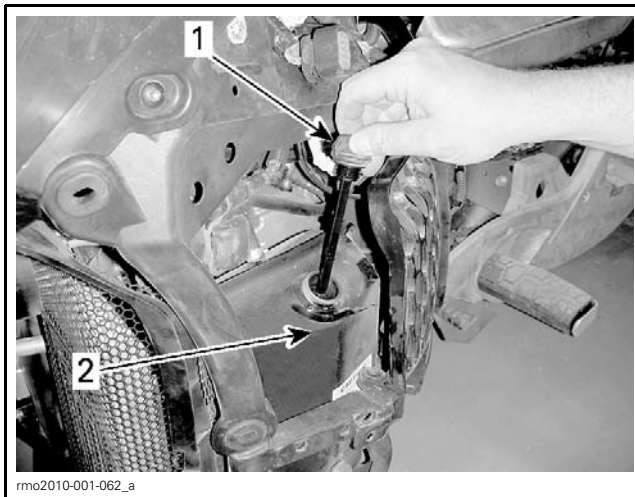

1. Oil dipstick
2. Oil tank

6. Wipe off the dipstick.
7. Reinsert and **completely screw in** the dipstick to assure an accurate reading.
8. Unscrew and remove the dipstick again.
9. Check the oil level on the dipstick. It should be near or equal to the upper mark.

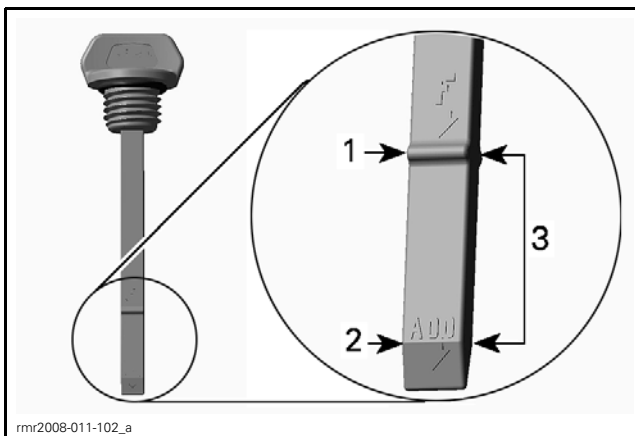

1. Full
2. Add
3. Operating range

If Oil Level is at or Near Upper Mark:

- Properly insert and tighten dipstick.
- Install the LH middle side panel as the reverse of removal.

If Oil Level is Under Operating Range:

- Add a small amount of recommended oil.
- Repeat the previous steps until oil level reaches the dipstick's upper (F) mark. **Do not overfill.**
- Properly insert and tighten dipstick.
- Install the LH middle side panel as the reverse of removal.

Clutch Fluid (SM5 Model)

Recommended Clutch Fluid

Use DOT 4 brake fluid from a sealed container. An opened container may be contaminated or may have absorbed moisture from the air.

Clutch Fluid Level Verification

The clutch fluid reservoir is near the reverse button on the left handlebar.

1. Park the vehicle on a firm, level surface.
2. Set the handlebar in the straight ahead position.
3. Wipe clean the cap area.
4. Use the Phillips head screwdriver located in the toolkit.
5. Unscrew cap retaining screws.



6. Carefully remove cap. Pay attention not to drop the cap seal.
7. Look inside the reservoir to see the fluid level.
8. Level should be within the maximum level line and the minimum level indicated by the protrusions in the bottom of reservoir.

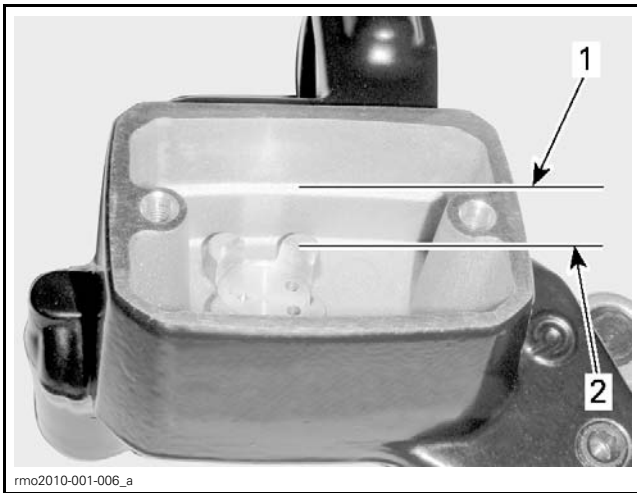

rmo2010-001-006_a

FLUID REMOVED FOR CLARITY PURPOSE

- 1. Maximum level line
- 2. Minimum level (top of protuberance)

9. Add recommended fluid as required. Do not overfill.

⚠ WARNING

Avoid getting brake fluid on skin or in eyes — it may cause severe burns. In case of contact with the skin, wash thoroughly. In case of contact with the eyes, immediately rinse with plenty of water for at least 10 minutes and then consult a doctor immediately.

- 10. Immediately wipe up spills if necessary.
- 11. Ensure that the seal located inside the cap is collapsed.
- 12. Reinstall the cap to the reservoir.
- 13. Tighten cap screws.
- 14. Wipe off reservoir if necessary.

Engine Coolant

⚠ WARNING

When opening the reservoir, the coolant can be very hot and spray out if the engine is hot. In order to avoid getting burned, check coolant level when engine is cold.

Recommended Coolant

The cooling system must be filled with distilled water and antifreeze solution (50% distilled water, 50% antifreeze).

For best performance, use BRP PREMIXED COOLANT (P/N 219 700 362)

Coolant Level Verification

⚠ WARNING

When opening the reservoir, the coolant can be very hot and spray out if the engine is hot. In order to avoid getting burned, check the coolant level when the engine is cold.

- 1. Park the vehicle on a firm, level surface.
- 2. Open the front storage compartment.
- 3. Remove the plastic rivet from the right service cover.

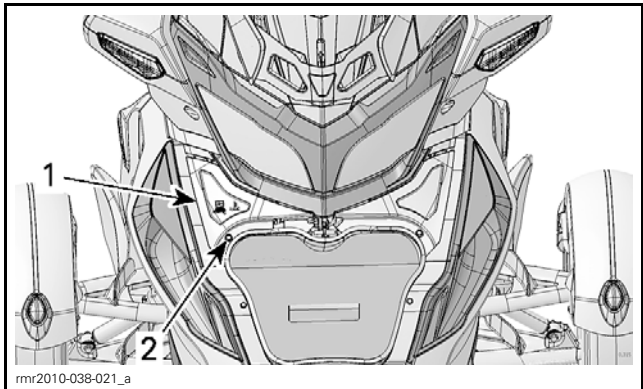

rmr2010-038-021_a

- 1. Right service cover
- 2. Plastic rivet

- 4. Lift lower portion of service cover then pull it toward the front.
- 5. Check the coolant level. Coolant must be visible without exceeding the MAX. level mark.

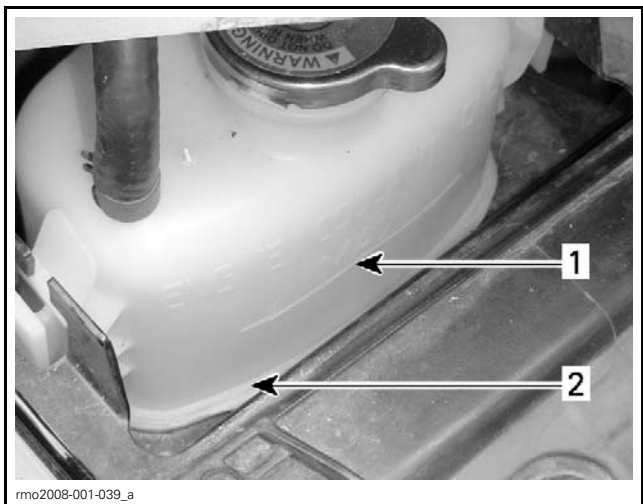

rmo2008-001-039_a

- TYPICAL
- 1. Coolant MAX. level mark
 - 2. Coolant must be visible

- 6. If required, add recommended coolant until it is visible in the reservoir without exceeding the MAX. level mark. Use a funnel to avoid spillage. Do not overfill.
- 7. Reinstall the service cover.

Brake Fluid

⚠ WARNING

Avoid contact of brake fluid with skin or eyes because it may cause severe burns. In case of contact with the skin, wash thoroughly. In case of contact with the eyes, immediately rinse with plenty of water for at least 10 minutes and then consult a doctor immediately.

NOTICE Do not overfill brake fluid reservoir.

Recommended Fluid

Use only DOT 4 brake fluid from a sealed container. An opened container may be contaminated or may have absorbed moisture from the air.

NOTICE To avoid serious damage to the braking system, do not use non-recommended fluids. Brake fluid can damage plastic and painted surface. Handle with care.

Brake Fluid Level Verification

⚠ WARNING

Clean filler cap before removing. Use only DOT 4 brake fluid from a sealed container.

1. Park the vehicle on a firm, level surface.
2. Unlatch and lift the seat.
3. Check the brake fluid level in both reservoirs, near the back of the seat. They should both be above the MIN. mark.



1. Brake fluid reservoir

4. Clean the filler caps before removing.
5. Add recommended fluid as required. **Do not overfill.**

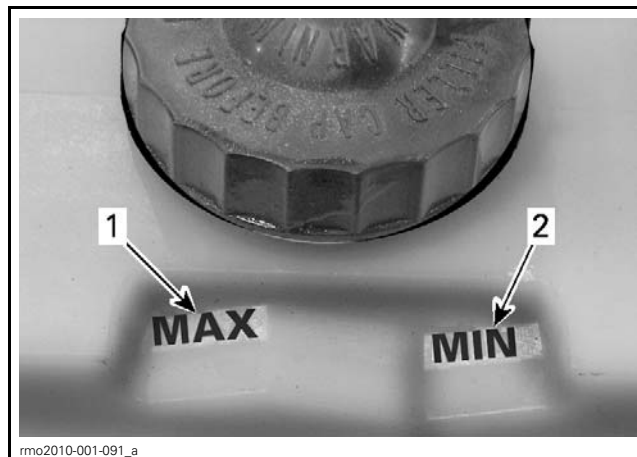

1. Brake fluid MAX. level mark
2. Brake fluid MIN. level mark

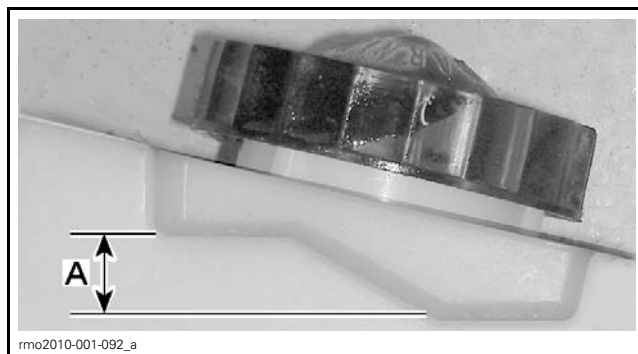

A. Operating range

6. Immediately wipe up spills if necessary.
7. Reinstall both caps of the reservoir.
8. Close the seat and ensure it is fully latched.

ADJUSTMENTS

Guidelines

All adjustments have already been performed at factory. It is only necessary to validate them. However, if readjustment is needed, refer to the appropriate *ROADSTER SHOP MANUAL* for the proper procedure.

Drive Belt

NOTICE Always verify drive belt tension with all parts at room temperature and the rear wheel lifted off the ground.

1. Place vehicle on a level surface.

NOTE: The area must be protected against wind and must have a very low background noise.

2. Set transmission to NEUTRAL.
3. Lift rear of vehicle by the frame until rear wheel is off the ground.

NOTICE Do not lift under rear shock absorber. Always lift by the frame. Refer to illustration.



TYPICAL - LIFT BY THE FRAME

4. To check the drive belt tension use the BELT TENSION METER (P/N 529 036 115).



5. Enter the following specifications to program the meter.

MASS	WIDTH	SPAN
8.4 g/m	28.0 mm/R	1028 mm



SONIC TENSION METER DISPLAY

NOTE: Refer to the manufacturer's instructions to set the informations into the device.

6. Turn rear wheel to align a wheel spoke with the swing arm.



TYPICAL - SWING ARM ALIGNS WITH A SPOKE

7. Position the sensor under the LH passenger footrest and hold the sonic tension meter sensor approximately 1 cm (1/2 in) from belt or closer without touching the belt.

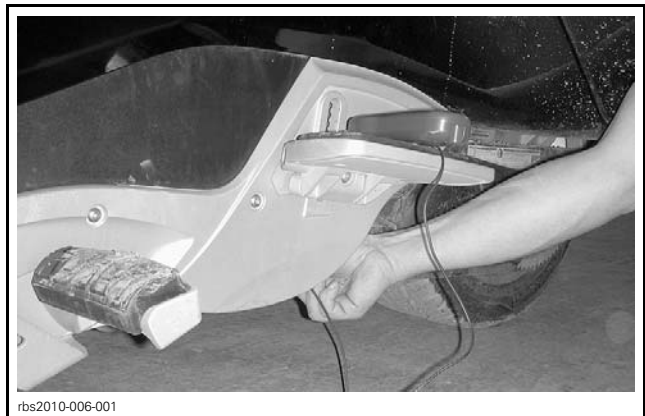

SPYDER RT

8. Tap the belt to make the belt vibrate and note the measurement.

9. Repeat step 8.

NOTE: The second value should be within $\pm 25N$. If no, repeat measurements until tolerance is met.

10. Repeat steps 6 to 9 for the 2 remaining wheel spokes.

The average of the 3 obtained values (at the 3 spokes) must be within the following range:

<p>DRIVE BELT TENSION (PARTS AT ROOM TEMPERATURE AND REAR WHEEL LIFTED)</p>
<p>450N \pm 150N</p>

If the tension of drive belt is out of specification, adjust drive belt as per *DRIVE BELT TENSION ADJUSTMENT*. Refer to *DRIVE SYSTEM* subsection in the proper *CAN-AM ROADSTER SHOP MANUAL*.

Clutch Lever

NOTE: The distance between the clutch lever and handgrip can be adjusted from position 1 (greatest distance) to position 4 (smallest distance).

1. Adjust the clutch lever as per the owner's preference.
 - 1.1 Push the clutch lever forward to release the adjuster dial. Hold in position.
 - 1.2 Turn the adjuster dial to the desired position aligning the dial number with the dot on the lever.
 - 1.3 Release the clutch lever.

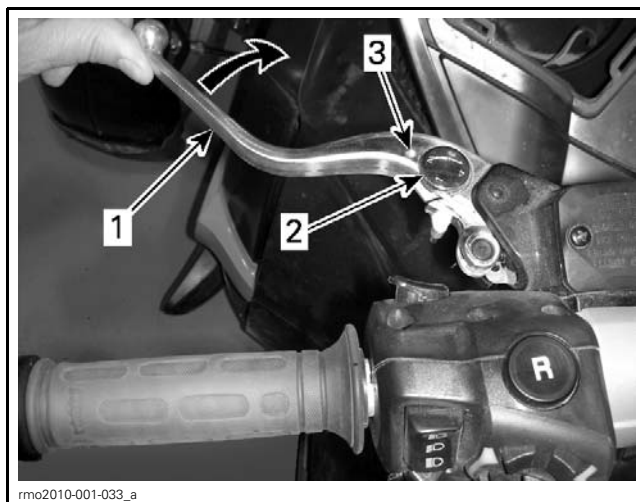

rmo2010-001-033_a
CLUTCH LEVER ADJUSTMENT

1. Clutch lever
2. Adjuster dial
3. Dot

Suspension

⚠ WARNING

Left and right adjusting cams must always be set at the same position. Never adjust one adjusting cam only. Uneven adjustment can cause poor handling and loss of stability, which could lead to an accident.

Front Suspension

NOTICE Before adjusting suspension, lift the front of vehicle using a jack to extend the suspension. This will ease turning the adjustment cam and will prevent a potential breakage of the adjustment plate.

1. Adjust the spring preload as per the owner's preference.
 - 1.1 Place the vehicle on a level surface.
 - 1.2 Engage the parking brake.

- 1.3 Adjust the spring preload by turning the cam with the adjusting wrench (stored in the tool kit).

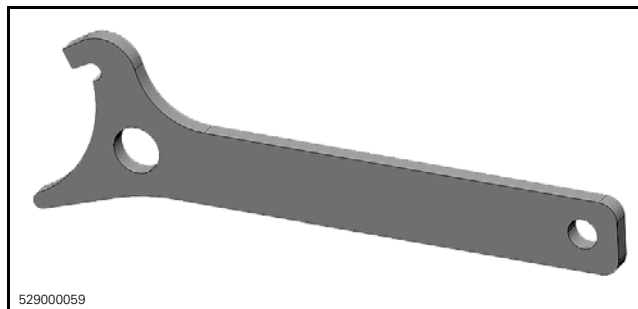

529000059
FRONT SUSPENSION ADJUSTING WRENCH

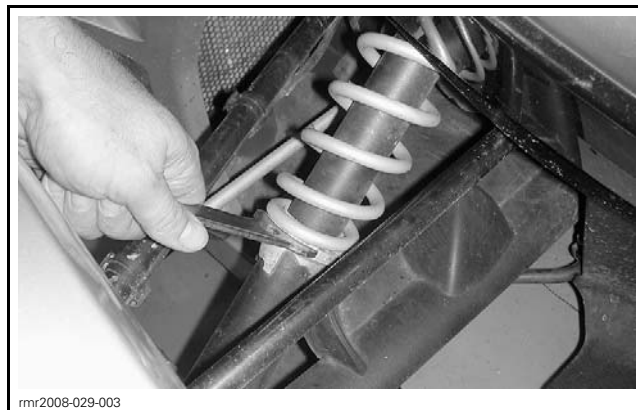

rnr2008-029-003
FRONT SUSPENSION CAM ADJUSTMENT

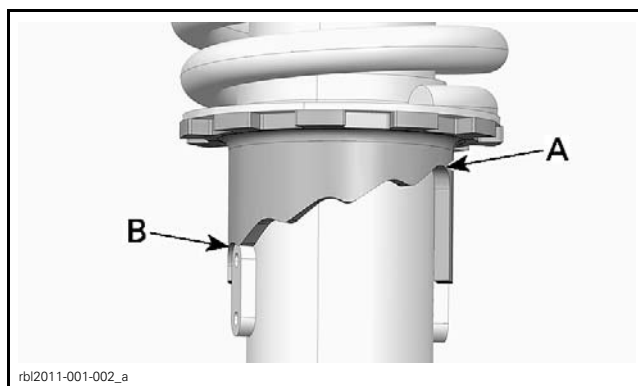

rib2011-001-002_a
A. Smooth adjustment (position 1)
B. Hard adjustment (position 5)

RECOMMENDED FRONT SHOCK ADJUSTMENT

LOAD	CAM POSITION
68 kg (150 lb) rider	1, 2
91 kg (200 lb) rider	3
68 kg (150 lb) rider with cargo	3
91 kg (200 lb) rider with cargo	4
Rider with passenger and cargo	5

ACS Rear Suspension

Models Without Compressor (Manual Adjustment)

The suspension pressure is adjustable by deflating or inflating the air spring. Use an air compressor and a pressure gauge.

To soften suspension, reduce the air pressure and to harden suspension, increase air pressure.

1. Adjust the air spring as per the owner's preference.
2. Refer to the following chart for proper adjustment.

⚠ WARNING						
MINIMUM PRESSURE 10 PSI / 70 kPa						
Do not exceed recommended pressure by 10 PSI / 70 kPa						
LOAD		PASSENGER + CARGO (lb / kg)				
		0	100/45	150/70	200/90	250/115
DRIVER	Lb/Kg	PSI/kPa	PSI/kPa	PSI/kPa	PSI/kPa	PSI/kPa
	150/70	20/135	40/275	50/345	60/415	70/485
	200/90	30/205	50/345	60/415	70/485	80/555
	250/115	40/275	60/415	70/485	80/555	90/625

704902072

NOTICE Do not exceed the maximum allowed pressure. This might damage the air suspension.

NOTE: When adjusting the pressure, do not put your weight on the vehicle and do not load cargo in the storage compartment.

The air spring is connected directly to an air hose with a schrader valve located under the seat.

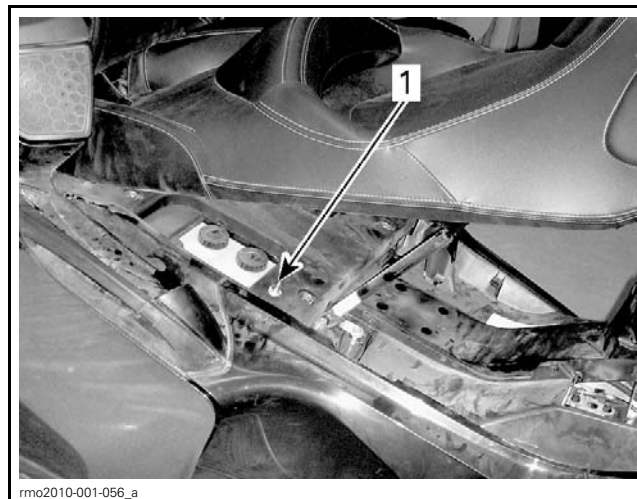

1. Schrader valve

NOTE: On models equipped with a remote adjustment, it is not necessary to adjust the suspension setting. The air spring will inflate automatically at the factory setting after the vehicle start up. Refer to the *SPYDER RT OPERATOR'S GUIDE* for details.

Lights

Headlights Aiming Verification

North American Models

1. Set the rear suspension air pressure to 0 kPa (0 PSI) using the schrader valve located under the seat.

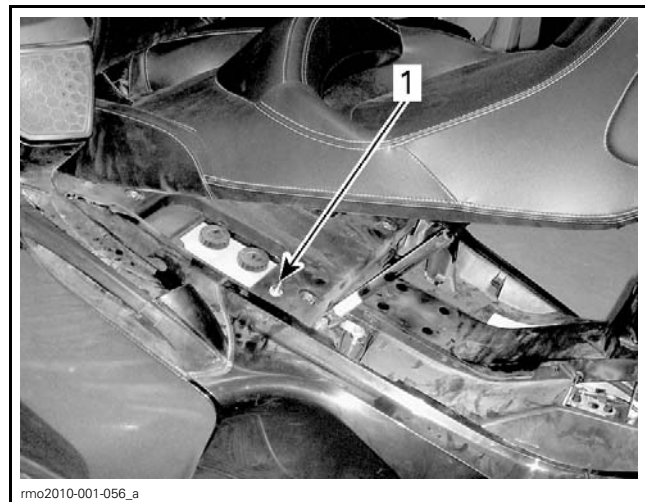

1. Schrader valve

2. Position the vehicle in front of a test surface as shown.
3. Have a person of at least 91 kg (200 lb) taking place on the driver's seat.

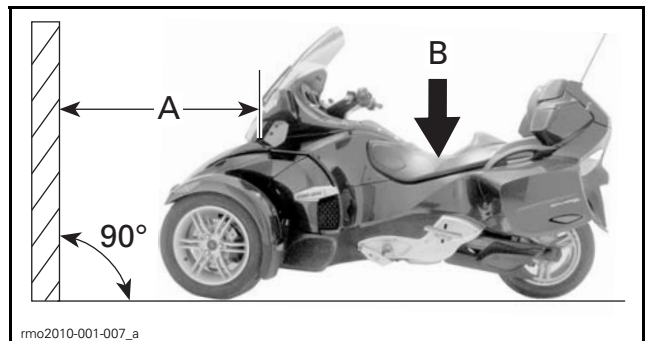

- A. 10 m (33 ft)
- B. 91 kg (200 lb)



4. Trace 2 lines parallel to the ground on the test surface as follows:

LINES ON THE TEST SURFACE	
Line A	642 mm (25.3 in) above ground
Line B	732 mm (28.8 in) above ground

- Select **low** beam.
- Beam aiming is correct when the focus point (brightest spot) of the headlight reflection is within the marks.

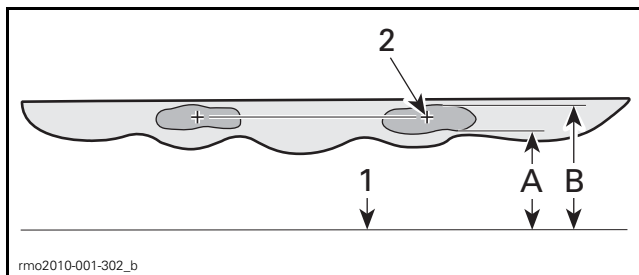

TYPICAL HEADLIGHT REFLECTION ON TEST SURFACE

- Ground
 - Focus point
- A. 642 mm (25.3 in) above ground
 B. 732 mm (28.8 in) above ground

CE Models (Low Beam)

NOTE: This verification is valid for either left-hand or right-hand traffic regulations.

- Set the rear suspension air pressure to 0 kPa (0 PSI) using the schrader valve located under the seat.

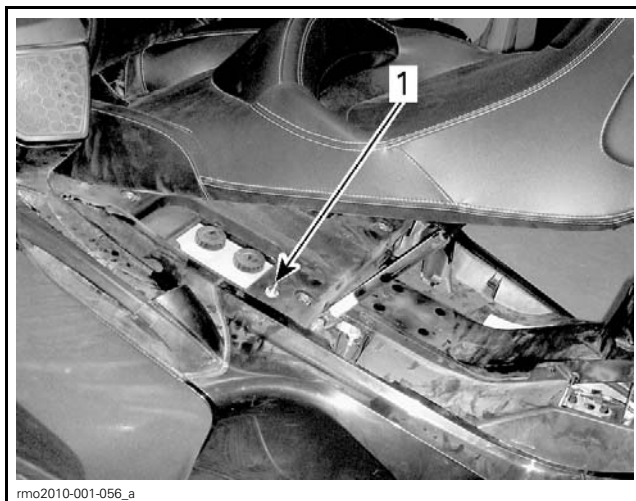

1. Schrader valve

- Position the vehicle in front of a test surface as shown.
- Have a person of at least 91 kg (200 lb) taking place on the driver's seat.

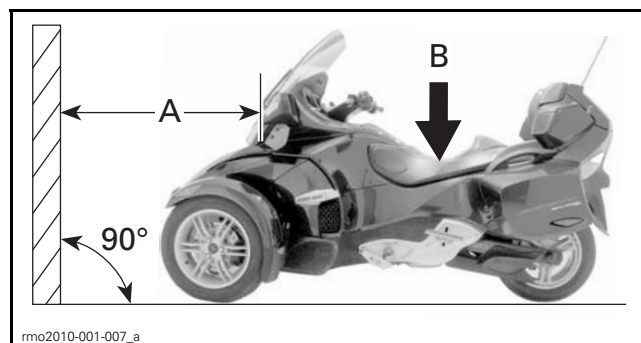

- A. 10 m (33 ft)
 B. 91 kg (200 lb)



4. Trace 2 lines parallel to the ground on the test surface as follows:

LINES ON THE TEST SURFACE	
Line A	415 mm (16.3 in) above ground
Line B	515 mm (20.3 in) above ground

- Select **low** beam.
- Beam aiming is correct when the focus point (brightest spot) of the headlight reflection is within the marks.

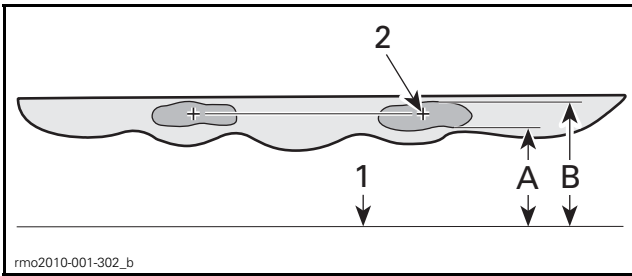

TYPICAL HEADLIGHT REFLECTION ON SURFACE TEST

- 1. Ground
- 2. Focus point
- A. 415 mm (16.3 in) above ground
- B. 515 mm (20.3 in) above ground

CE Models (High Beam)

1. Follow steps 1 and 2 of the low beam verification procedure.
2. Trace 2 lines parallel to the ground on the test surface as follows:

LINES ON THE TEST SURFACE	
Line A	800 mm (31.5 in) above ground
Line B	850 mm (27-1/2 in) above ground

3. Select the **high** beam.

Beam aiming is correct when the focus point (brightest spot) of the headlight reflection is within the marks.

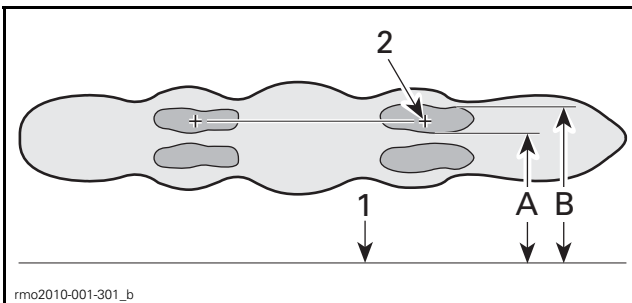

TYPICAL HEADLIGHT REFLECTION ON TEST SURFACE

- 1. Ground
- 2. Focus point
- A. 800 mm (31.5 in) above ground
- B. 850 mm (33.5 in) above ground

► Headlights Aiming Adjustment

1. Remove both middle side panels.

Upper Headlight Units

2. To adjust headlight beam, turn the adjustment knob. Adjust both headlights evenly.

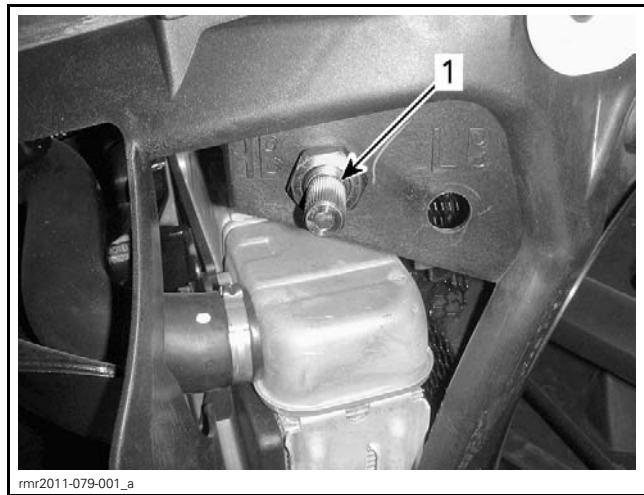

RH SIDE SHOWN
1. Adjustment knob "HB"

HEADLIGHT BEAM ADJUSTMENT	
Raise beam	Turn knob clockwise
Lower beam	Turn knob counterclockwise

Lower Headlight Units (European Models Only)

1. To adjust headlight beam, turn the adjustment knob. Adjust both headlights evenly.

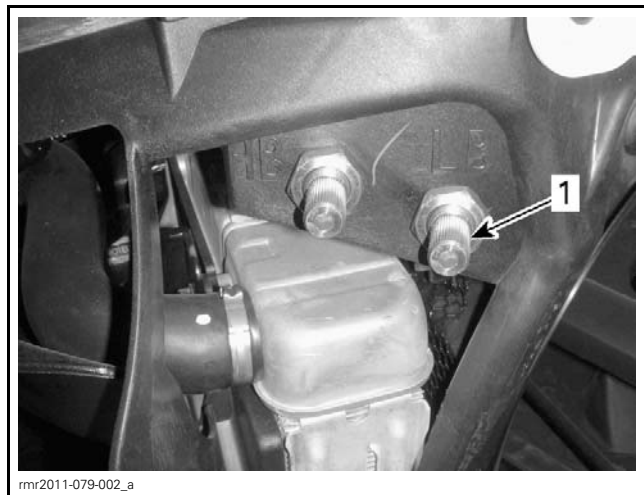

RH SIDE SHOWN
1. Adjustment knob "LB"

HEADLIGHT BEAM ADJUSTMENT	
Raise beam	Turn knob clockwise
Lower beam	Turn knob counterclockwise ◀



B.U.D.S. Programming

Always use the latest B.U.D.S. version on your shop computer. At time of printing, the latest B.U.D.S. version is P2.3.29. It is available from the following web site:

WWW.BOSSWEB.BRP.COM

NOTICE During data transfer, make sure that:

- Voltage (12V) remains stable before starting update. Charge the battery or use a power pack to have enough power.
- Although screen "freezes" for a while, remain on the B.U.D.S. because update still continues
- Never disconnect any cable while updating ECM.

MANDATORY TOOLS	
A personal computer (laptop or desktop)	
MPI-2 INTERFACE CARD (P/N 529 036 018)	
MPI-2 DIAGNOSTIC CABLE (P/N 710 000 851)	
OPTIONAL TOOL	
Extension cable available at electronic retail outlets. Do not exceed 7.5 m (25 ft)	

NOTE: B.U.D.S. is not used to program the hard keys (included keys are ready to use).

Use B.U.D.S. to

- Enter Customer's Name
- Reset Trip Hours and Trip Distances
- Reset Last Service
- Set Speedometer Units
- Set Cluster Language
- Check fault codes (if any).

Connecting PC to Vehicle

1. Remove service cover from vehicle.
2. Connect the PC to vehicle. Refer to the latest edition of *CAN-AM ROADSTER B.U.D.S. SOFTWARE AND COMMUNICATION TOOLS* for the proper connecting procedure.
3. Ensure that the status bar shows the proper protocol and proper ECU number. Refer to the following table.

MODEL	PROTOCOL	ECU QUANTITY
SM5	KW2000 500K	5
SE5	KW2000 500K	6

4. Press READ DATA button from the tool bar to initiate communication with the vehicle.

Entering Customer's Name

NOTE: When starting the vehicle, the multifunction display will show the name of the customer; for example: "HI JOHN SMITH". If the customer's name is not programmed, only "HI" will be visible when turning the vehicle ON.

1. Click on the VEHICLE tab to open the vehicle information page.

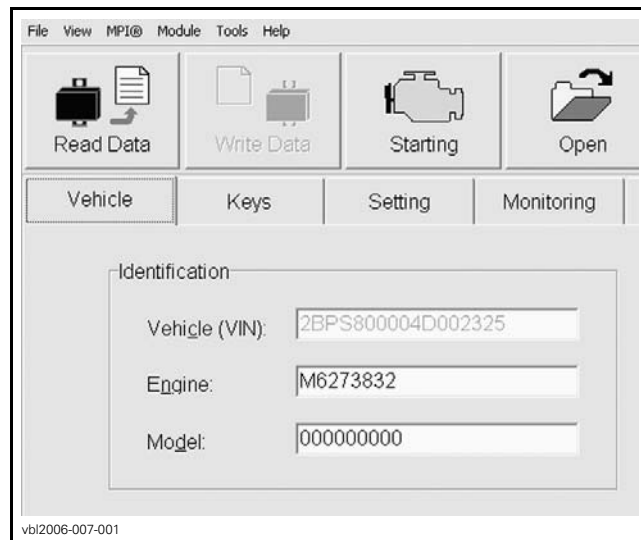

2. Type the name of the customer.

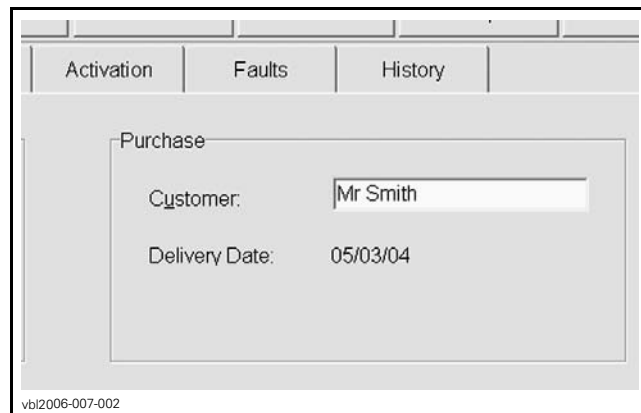

3. Click on WRITE DATA to save the information in the vehicle ECM.

NOTE: After you are finished typing the name, B.U.D.S. automatically updates the Delivery Date on the screen.

Resetting Trip Hours and Trip Distances

1. Ensure that the VEHICLE tab is selected.
2. Click on the RESET TRIP buttons to reset the information.

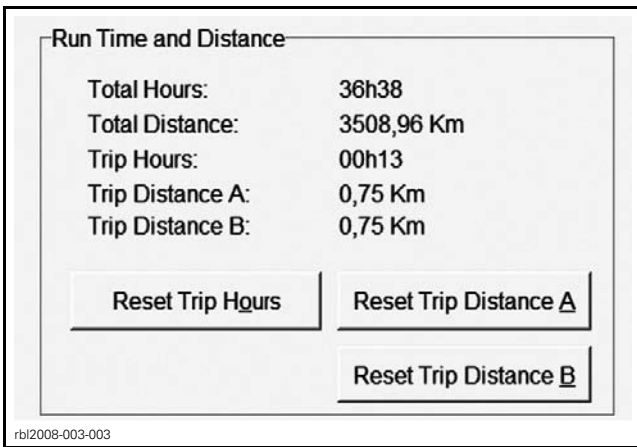

NOTE: It can also be done directly on the info-center, using the selector button.

Resetting Last Service

1. Click on the RESET SERVICE button to reset the informations.

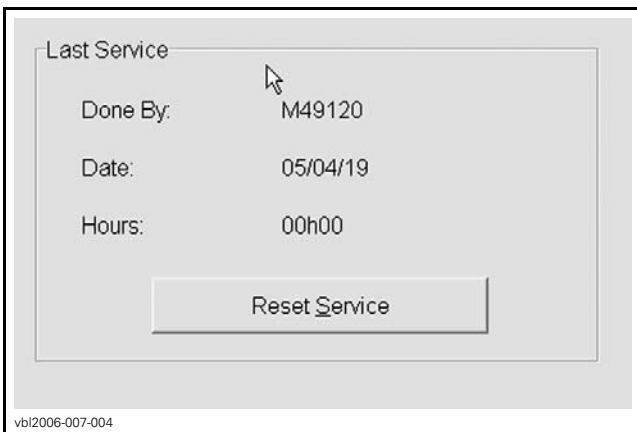

NOTE: After each maintenance service, Last Service should be reset to keep a good track of vehicle service history.

Speedometer Units

NOTE: The speedometer is factory preset in miles but it is possible to change it to kilometer reading. Any unit modification is applied to the speedometer, odometer and trip meter.

1. Select the SETTING tab in B.U.D.S.
2. Select CLUSTER page.
3. Select **Metric** or **Imperial** from the **Cluster Units** section.

NOTE: No data will be lost when changing this setting.

Cluster Language (chosen by customer according to availability)

NOTE: The default language displayed in the multi-function gauge is English. To change the language displayed in the multifunction gauge.

1. Select SETTING tab at the top of the page.
2. Select CLUSTER tab at the bottom of the page.
3. Select desired language in the **Cluster Language** field.

NOTE: If the language selection is not available, the gauge may not have the latest software version available.

Ending a B.U.D.S. Session

NOTICE Clear the fault(s) after a problem has been solved. This will properly reset the appropriate counter(s).

1. Click on FAULT tab and check if there are active faults. If so, service vehicle then clear the faults in B.U.D.S.
2. Click on WRITE DATA button to transfer new settings and information to the modules.

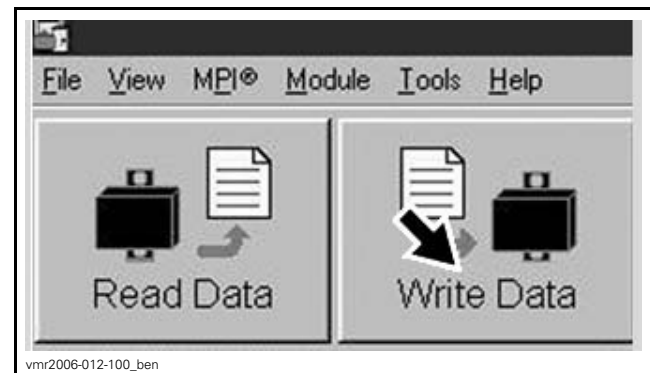

WRITE DATA BUTTON

3. Click on EXIT button (right most) to end session.
4. Reinstall DCL connector into its housing.
5. Reinstall service cover on vehicle.

ASSEMBLY INSPECTION

Inspect the following parts to make sure that the vehicle is properly assembled.

1. Front compartment cover and seat locks
2. Passenger grab handles
3. Front wheel nuts torque (must be 105 N•m (77 lbf•ft))
4. Rear shock absorber retaining nuts torque (must be 48 N•m (35 lbf•ft))
5. Suspension arm ball joint cotter pins
6. Tie rod end nuts and cotter pins

7. Rear axle nut and cotter pin
8. Gearshift pedal operation
9. Parking brake operation
10. Brake lines
11. Foot pegs.

NOTE: Refer to the Predelivery Check List to confirm that all items are covered by your inspection.

FINAL INSPECTION

Vehicle Test Run

Ride the vehicle to ensure proper operation of all systems and components and check the following items:

1. Instrument cluster operation.
2. Indicator-warning pilot lamps functioning on power up.
3. Display of safety message in cluster.
4. Starter interlock mechanism operation.
 - 4.1 Press start button to make sure engine can not be started if M button is not depressed to acknowledge safety message.
5. Cluster mode button and set button operation.
6. Error messages in cluster (correct if necessary).
7. LH handlebar multifunction switch operation.
8. Ignition keys allow the engine to start.
9. Reverse button operation.
 - 9.1 Start engine.
 - 9.2 Shift in first gear, slightly apply on throttle then release.
 - 9.3 Shift in reverse, slightly apply on throttle then release.
 - 9.4 Shift in neutral position, slightly apply on throttle then release.
10. Throttle operation.
 - The throttle is the right handgrip, and it controls engine speed. To increase engine speed, roll the throttle toward you. To decrease engine speed, roll the throttle away from you. The throttle is spring loaded and should return to idle when you release it.
11. Clutch lever operation (SM5 Model).
 - The clutch lever is in front of the left handgrip. The clutch controls the transmission of power from the engine to the rear wheel. The lever is squeezed to disengage power and released to engage power.
12. Engine stop switch operation.
 - The engine stop switch is near the right handgrip. It has two positions and must be set to the run position before you can start the engine. It allows you to stop the engine anytime without removing your hand from the handlebar.
13. Operation of the following lights:
 - Headlights (HI and LO beam)
 - Taillights
 - Brake light
 - Position lights
 - Turn signal lights
 - Hazard lights
 - Licence plate light
 - Back up light
 - Front storage light (option package).
14. Dimmer switch operation.
15. Headlight overrun button operation.
 - There is a headlight override button on the front of the right handgrip.
16. Horn operation.
 - The horn button is located near the left handgrip.
17. Brake operation.
 - The brake pedal is in front of the right footpeg.
 - Press it down to operate.
 - This pedal brakes all three wheels.
 - 17.1 Ensure brake pedal is firm when pressure is applied and that it returns freely.
18. Electronic parking brake operation.
 - The parking brake switch is located on the central panel.
 - 18.1 Press it down to apply the parking brake.
 - 18.2 Press the switch down a second time to release the parking brake.
 - 18.3 Ensure parking brake is shut-off.
19. Shifter operation.
20. Leakage of the following fluids:
 - Fuel
 - Engine oil
 - Engine coolant
 - Brake fluid
 - Clutch fluid
21. Proper operation of seat release and hood release using key.
22. Absence of abnormal noises or vibrations.

23. Tool kit, DVD and Operator's Guide in front storage compartment.
24. Radio operation using, front and rear controls (option package).
25. Front and rear heated grips operation (option package).
26. iPod® and MP3 audio player wires stowed in rear top storage compartment.
27. Complete applicable recall or factory-directed modification.
28. Ensure that hang tag is on vehicle handle bars (to be removed by owner).

2. Give *OPERATOR'S GUIDE* and *SAFETY DVD* to customer.

The customer and dealer must read and sign the *PREDELIVERY CHECK LIST*.

Hang tag is to be removed by the owner only.

Any person who rides this vehicle should read and understand all the information given on hang tag and safety labels before riding.

Vehicle Cleaning

NOTICE Do not clean the windshield with alkaline or acid cleaner, gasoline or solvent to avoid windshield damage.

NOTICE Do not polish windshield with any plastic cleaner or polisher.

NOTICE Never use a high pressure washer to clean the vehicle. USE LOW PRESSURE ONLY (like a garden hose). The high pressure can cause electrical or mechanical damage.

NOTICE It is necessary to use flannel cloths on plastic parts to avoid damaging surfaces.

NOTICE Do not wash the seat with a vinyl or plastic cleaner because the seat may become slippery.

NOTICE Certain plastic or vinyl cleaners will damage the seat cover. Use only mild detergent, such as soap specially formulated for motorcycles or automobiles.

1. Wet the vehicle thoroughly with water.
2. Wash the vehicle with water mixed with a mild detergent, such as soap specially formulated for motorcycles or automobiles.
3. Dry the vehicle with a chamois or a soft towel.

NOTE: While washing the vehicle, check for grease or oil. If necessary, use a mild automotive degreaser and follow the manufacturer's instructions.

Delivery to Customer

1. Complete the *PREDELIVERY CHECK LIST*.

SPECIFICATIONS

MODEL			SPYDER RT		
ENGINE					
Engine type			ROTAX 991 60° V-Twin 4-stroke, Dual Over Head Camshaft (DOHC), liquid cooled		
Number of cylinders			2		
Number of valves			8 valves		
Bore			97 mm (3.82 in)		
Stroke			68 mm (2.68 in)		
Displacement			998 cm ³ (60.9 in ³)		
Compression ratio			12.2:1		
Lubrication	Type		Dry sump with separate oil tank and oil cooler		
	Oil filter	Engine		BRP Rotax paper type, replaceable	
		Transmission (SE5)		BRP Rotax paper type, replaceable	
	Engine oil Capacity	Oil change with new engine filter	SM5	3.9 L (4.1 qt (U.S. liq.))	
		Oil change with new engine filter	SE5	4.2 L (4.4 qt (U.S. liq.))	
		Oil change with new engine and HCM filters		4.3 L (4.5 qt (U.S. liq.))	
Recommended Engine Oil		XPS SYNTHETIC BLEND OIL (SUMMER GRADE) (P/N 293 600 121) or a 5W 40 semi-synthetic (minimum) or synthetic motorcycle oil meeting the requirements for API service SL, SJ, SH or SG classification.			
Clutch	SM5 model	Type		Wet, multi-plate, manual operation through a hydraulic piston, vacuum assist	
		Fluid		DOT 4	
	SE5 model	Type		Centrifugal clutch + wet multi-plate clutch automatically controlled by TCM	
		Engage-ment		2000 +/- 200 RPM (centrifugal)	
		Stall		3200 +/- 200 RPM (centrifugal)	
		Exhaust system		2 into 1 with catalytic converter	
Air filter		Paper element			
GEARBOX					
Type	SM5		Sequential Manual 5-speed (SM5) with reverse		
	SE5		Sequential Electronic 5-speed (SE5) with reverse		
COOLING SYSTEM					
Type			Liquid cooled, single radiator with cooling fan		
Coolant	Type		Ethyl glycol/water mix (50% coolant, 50% distilled water). Use BRP PREMIXED COOLANT (P/N 219 700 362) or coolant specifically designed for aluminum engines		
	Capacity		3.2 L (.85 U.S. gal.)		

SPECIFICATIONS

MODEL		SPYDER RT
ELECTRICAL SYSTEM		
Magneto generator output		650 W
Ignition system type		Electronic ignition with dual output coil
Ignition timing		Electronically controlled, not adjustable
Spark plug	Quantity	2
	Make and type	NGK DCPR8E (apply heat-sink paste P12 (P/N 420 897 186) on spark plug threads)
	Gap	0.8 mm to 0.9 mm (.031 in to .035 in)
Engine RPM limiter setting	Forward	10 000 RPM
Battery	Type	Maintenance free
	Voltage	12 volts
	Nominal rating	21 A•h
	Recommended charging rate	2 A
Headlight	CA/US Models	2 x 55 W Halogen
	CE Models	High beam: 2 x 55 W Halogen Low beam: 2 x 60 W Halogen
Fog light (Spyder RT-S)		2 x 35 W Halogen
Taillight/brake light		2 x 0.25 W/2 x 2.5 W
Turn signal lights	Front	2 x 4.5 W
	Rear	2 x 20 W
Position lights		2 x 5 W
License plate light		5 W
Backup light		2 x 20 W
Day light (Spyder RT-S)		0.5 W
Front storage compartment light (Spyder RT-S)		0.15 W
Fuse (In storage Compartment)	Lights: tail, position, plate & day Vbat: Cluster, VIM & DLC	15 A
	Vbat Control: main relays Vkey: SAS, YRS, VCM, ECM, D.E.S.S., PRS & MSR	10 A
	Vbat: Main relay Vrelayed: WPM, CL, FG, CTG, PBS pilot light, TCM, DPS	20 A
	Vbat: Cooling fan relay	15 A
	Vbat: Hazard, brake light switch	10 A
	Vbat: radio (XM, CB, GPS, "iPod")	15 A
	Vbat: Backup actuator & trailer module	10 A
	Vbat: Horn, shedding relay Vrelayed: suspension relay, heated grips, HA, LED Pilot lights: CSS, FHS, FGS	20 A
	Vbat: Accessory plugs	10 A
	Vrelayed: ECM	5 A
	Vrelayed: Injectors & ignition coils	15 A
	Vrelayed: HO2S1 & 2, EVAP, CAPS, fuel pump motor, CSV, pre-starting relay	15 A

MODEL		SPYDER RT	
ELECTRICAL SYSTEM (cont'd)			
Fuse (Under seat)	Accessories		40 A
	TCM valves (SE5 model)		20 A
	Rectifier		60 A
	Main fuse		40 A
	Dynamic Power Steering (DPS) motor		40 A
	VSS pump		40 A
	Headlights		30 A
	VSS valves		25 A
FUEL SYSTEM			
Fuel delivery	Type	Multi-point Electronic Fuel Injection (EFI) with ETC (Electronic Throttle Control) Dual throttle body (51 mm) with an actuator	
Fuel pump	Type	Electrical module in fuel tank	
Idle speed		1400 ± 100 RPM (electronically controlled, not adjustable)	
Fuel	Type	Regular unleaded gasoline	
	Octane rating	Inside North America	Recommended for optimum performance: 91 (R+M)/2 Minimum: 87 (R+M)/2
		Outside North America	Recommended for optimum performance: 95 RON Minimum: 92 RON
Fuel tank capacity		25 L (6.6 U.S. gal.)	
DRIVE SYSTEM			
Final drive type		Carbon reinforced drive belt	
Final drive ratio		28/79	
STEERING			
Type		Dynamic Power Steering (DPS)	
FRONT SUSPENSION			
Suspension type		Double A-arm with anti-roll bar	
Suspension travel		151 mm (5.9 in)	
Shock absorber	Qty	2	
	Type	Oil damper	
Spring preload adjustment		5 position cam adjustment	
REAR SUSPENSION			
Suspension type		Air Controlled Suspension (ACS) Compressor-controlled (ACS with remote adjustment only) Swing arm with monoshock	
Suspension travel		145 mm (5.7 in)	
Shock absorber	Qty	1	
	Type	Oil damper	
Preload adjustment (ACS with manual adjustment)		Adjustable air pressure: 135 kPa to 625 kPa (20 PSI to 90 PSI)	
Preload adjustment (ACS with remote adjustment)		5 positions	

SPECIFICATIONS

MODEL		SPYDER RT
BRAKES		
Type	Foot-actuated, fully integrated hydraulic 3-wheel braking system with ABS and EBD	
Front brake	Dual discs (250 mm (9.8 in) x 6 mm (.24 in)) with 4 piston calipers	
Rear brake	Single disc (250 mm (9.8 in) x 6 mm (.24 in)) with 1 piston caliper	
Brake fluid	Capacity	530 ml (17.9 U.S. oz)
	Type	DOT 4
Parking brake	Mechanical, electrically actuated to the rear caliper	
Minimum brake pad thickness	1 mm (.04 in)	
Minimum brake disc thickness	5.33 mm (.21 in)	
Maximum brake disc warpage	0.13 mm (.005 in)	
TIRES		
Type (use only tires recommended by BRP)	Front	Kenda KR21 MC 165/65R14 47H (special motorcycle type)
	Rear	Kenda KR21 MC 225/50R15 76H (special motorcycle type)
Pressure	Front	Nominal.: 103 kPa (15 PSI) Min.: 89 kPa (13 PSI) Max.: 117 kPa (17 PSI)
	Rear	Nominal.: 193 kPa (28 PSI) Min.: 179 kPa (26 PSI) Max.: 207 kPa (30 PSI) NOTE: The pressure difference between the left and right side tire should not exceed 3.4 kPa (.5 PSI).
Minimum tire tread depth	Front	2.5 mm (3/32 in)
	Rear	4 mm (5/32 in)
WHEELS		
Size (diameter X width)	Front	355 mm (14 in) x 127 mm (5 in)
	Rear	381 mm (15 in) x 178 mm (7 in)
Front wheel nuts torque	90 N•m to 120 N•m (66 lbf•ft to 89 lbf•ft)	
Rear drive axle nut torque	123 N•m to 137 N•m (91 lbf•ft to 101 lbf•ft)	
DIMENSIONS		
Overall length	2 667 mm (105 in)	
Overall width	1 572 mm (62 in)	
Overall height	▶ 1 473 mm (58 in) ◀	
Seat (top) height	▶ 772 mm (30.4 in) ◀	
Wheelbase	1 708 mm (67 in)	
Front wheel track	1 384 mm (54.5 in)	
Ground clearance, front and under engine	115 mm (4.5 in)	

MODEL		SPYDER RT
WEIGHT AND LOADING CAPACITY		
Dry weight (Spyder RT)		▶ 421 kg (928 lb) ◀
Dry weight (Spyder RT Audio & Convenience Package)		413 kg (911 lb)
Dry weight (Spyder RT-S)		422 kg (930 lb)
Front storage compartment	Capacity	55 L (14.5 U.S. gal.)
	Maximum load	16 kg (35 lb)
Glove box	Capacity	1.8 L (.5 U.S. gal.)
	Maximum load	2 kg (4 lb)
Side storage compartment	Capacity	23.5 L (6.2 U.S. gal.)
	Maximum load	7 kg (15 lb)
Rear storage compartment	Capacity	40.5 L (10.7 U.S. gal.)
	Maximum load	9 kg (20 lb)
Total vehicle load allowed (including operator, passenger, cargo and added accessories)		240 kg (525 lb)
Gross vehicle weight rating (GVWR)		663 kg (1,462 lb)
Maximum weight on trailer tongue		18 kg (40 lb)
Maximum towed weight (trailer and cargo)		180 kg (400 lb)

Because of our ongoing commitment to product quality and innovation, BRP reserves the right, at any time, to make changes in design and specifications and/or to make additions to, or improvements in its products without imposing any obligation upon itself to install them on its previously manufactured products.