

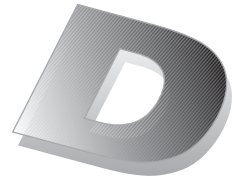

**ROADSTER**  
**PREDELIVERY**  
Bulletin



November 25, 2010 Subject: **Can-Am™ Spyder™ RS Predelivery Inspection**

No. **2011-1**

**REVISION 1**  
**March 23, 2011**

YEAR	MODEL	MODEL NUMBER	COUNTRY	PREDELIVERY KIT	SERIAL NUMBER
2011	Spyder® RS SM5	A1BA	Canada United States of America	(P/N 703 100 230)	All
		A1BB	Europe		
	Spyder RS SE5	A2BA, A2BE	Canada United States of America		
		A2BF	Europe		
	Spyder RS-S SM5	B6BA, B6BC	Canada United States of America		
		B6BD	Europe		
	Spyder RS-S SE5	B1BA, B1BC	Canada United States of America		
		B1BB, B1BD	Europe		

► Underlined text(s) between arrows is (are) modified element(s) to the original publication. ◀

## TABLE OF CONTENTS

	Page		Page
<b>IMPORTANT NOTICE</b> .....	<b>3</b>	Diagnostic Link Cable (DLC) .....	10
<b>UNCRATING</b> .....	<b>4</b>	Mudguards .....	10
Crate Cover Removal .....	4	Front Fenders .....	11
Sub-crate Removal .....	4	Rear Fender .....	12
Parts Check.....	4	Low Beam Light (CE Models) .....	12
Vehicle Removal .....	5	Hang Tag and Safety Labels .....	13
►Wheel Installation◀ .....	6	Licence Plate Installation .....	14
►Tires Pressure◀.....	6	Accessories Installation.....	14
<b>PARTS TO BE INSTALLED</b> .....	<b>6</b>	Vehicle Decals.....	14
Battery .....	6	<b>FLUIDS</b> .....	<b>14</b>
Front Storage Compartment .....	8	General Guidelines .....	14
AAPTS (Ambient Air Pressure and Temperature Sensor) Installation .....	9	Fuel.....	14
Horn Connection.....	10	Clutch Fluid (SM5 Model) .....	15
Hood Latch Release Cable .....	10	Engine Coolant.....	15
		Brake Fluid.....	15

Engine Oil.....	16
<b>BODY PARTS INSTALLATION .....</b>	<b>18</b>
Front Panels.....	18
Upper Side Panels.....	19
LH Rear Panel.....	19
Service Cover .....	19
<b>ADJUSTMENTS .....</b>	<b>19</b>
Guidelines .....	19
Drive Belt .....	19
Clutch Lever.....	20
Suspension .....	20
►Lights◄ .....	22
B.U.D.S. Programming.....	23
Cluster Units and Clock Units Setting .....	26
<b>ASSEMBLY INSPECTION .....</b>	<b>26</b>
<b>FINAL INSPECTION .....</b>	<b>26</b>
Vehicle Test Run .....	26
Vehicle Cleaning .....	27
Delivery to Customer .....	27
<b>SPECIFICATIONS .....</b>	<b>28</b>

## IMPORTANT NOTICE

This bulletin must be used in conjunction with the check list enclosed in the bag with the *OPERATOR'S GUIDE*. Make sure that Spyder roadster *PRE DELIVERY CHECK LIST* is completed and signed.

### WARNING

To obtain warranty coverage, predelivery procedures must be performed by an authorized BRP Can-Am roadster dealer/distributor. Apply all necessary torques as indicated.

**NOTE:** The information and components/system descriptions contained in this document are correct at the time of publication. BRP however, maintains a policy of continuous improvement of its products without imposing upon itself any obligation to install them on products previously manufactured.

Due to late changes, there might be some differences between the manufactured product and the descriptions and/or specifications in this document. BRP reserves the right at any time to discontinue or change specifications, designs, features, models or equipment without incurring obligation.

The illustrations in this document show the typical construction of the different assemblies and may not reproduce the full detail or exact shape of the parts. However, they represent parts that have the same or similar function.

The content of this bulletin is designed as a guideline only. All mechanics performing predelivery procedures should have attended the current model-year service training.

Further information or inquiries should be directed to your service representative and specific *SHOP MANUAL* sections.

Make sure the customer receives the *OPERATOR'S GUIDE*, *PREDELIVERY CHECK LIST* signed copy and *SAFETY DVD*.

### WARNING

Torque wrench tightening specifications must be strictly adhered to. Where specified, install new locking devices (e.g. lock tabs, elastic stop nuts). If the efficiency of a locking device is impaired, it must be renewed.

# UNCRATING

## Crate Cover Removal

**NOTICE** Allowing the crate to drop may cause serious damage to vehicle.

1. Position the crate on a firm, level surface.
2. Carefully cut both ends of crate tarpaulin to locate the rear of vehicle.

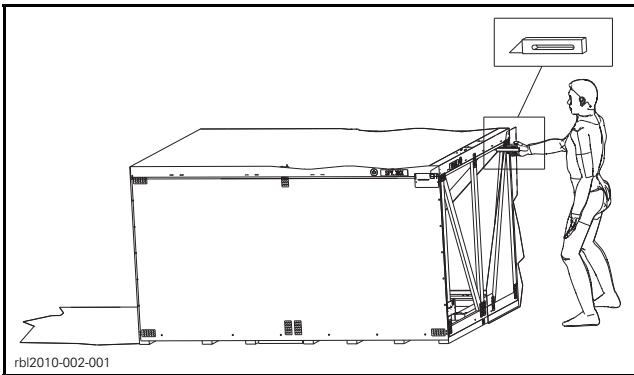

CUT BOTH END OF CRATE TARPAULIN

3. Remove all screws holding crate cover to crate base.
4. Tilt cover from the rear side of the vehicle.

**NOTICE** Do not raise cover vertically. Tilt cover located on the rear side of the vehicle. Refer to illustration.

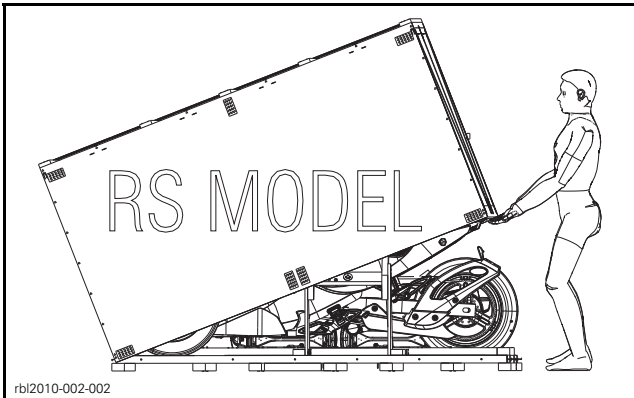

TILT COVER THEN PULL IT

**NOTICE** The crate cover must be pulled toward the outside while lifting it to avoid to damage vehicle.

NOTE: Screws that are used are Robertson† #2 type (or equivalent) that require the use of an appropriate screwdriver.

† Robertson is a registered trademark of Robertson Inc.

## Sub-crate Removal

**NOTICE** Be careful not to scratch the cover bumper and the front fascia.

NOTE: The sub-crate is located on the left side of vehicle and it contains the front storage compartment.

1. Remove protective foam from vehicle.
2. Remove all screws holding sub-crate to crate base.
3. Assisted by another person, carefully lift up the sub-crate.



1. Sub-crate

## Parts Check

Ensure that the crate includes the following items (inside front storage compartment):

DESCRIPTION	MODEL	QTY
Operator's guide	All	1
Predelivery check list		1
Safety DVD		1
Predelivery kit		1
Service center panel		1
Mudguard		2
Wheel caps		2

The predelivery kit should included the following items:

DESCRIPTION (LOCATION)	QTY
M6 X 20 hexagonal flange screw (front storage compartment)	4
M6 X 12 hexagonal flange screw (front storage compartment)	2
M6 panel nut (body panels)	4
M6 x 20 Torx screw (body panels)	4
Plastic washer (body panels)	4
M8 x 35 hexagonal flange screw (front fender)	8
Sleeve (front fender)	8
M6 X 20 hexagonal flange screw (AAPTS sensor)	1
M6 caged nut (AAPTS sensor)	1
Foam (AAPTS sensor)	1
Locking tie (rear fender)	3
M6 X 20 Torx screw (rear fender)	4
Plastic washer (rear fender)	4
M6 elastic flange nut (rear fender)	4
M6 panel nut (mudguards)	4
M6 x 20 Torx screw (mudguards)	4
<a href="#">▶ Battery installation kit (2 bolts and 2 nuts)</a>	<a href="#">1◀</a>

## Vehicle Removal

### **⚠ WARNING**

SE5 models are automatically set in neutral position when engine is stopped. Always apply parking brake before working on vehicle.

### **⚠ WARNING**

No one should be standing in front or at the back of the vehicle while straps are being cut.

NOTE: Parking brake pedal brakes only the rear wheel. Press it down to operate. The parking brake pedal is behind the operator's left footpeg.

1. Remove straps retaining front vehicle to crate skid.

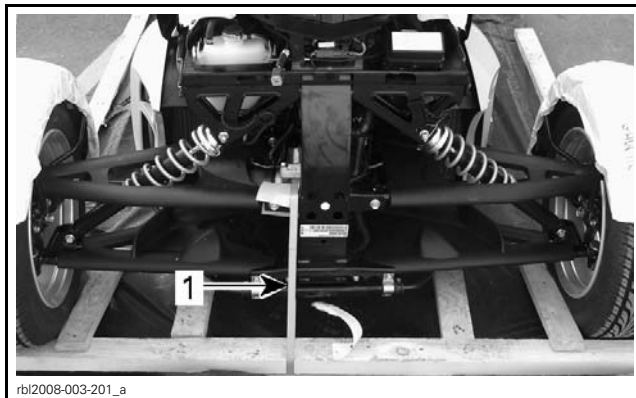

1. Front straps

2. Remove straps on the side of vehicle.



1. Side straps

**NOTICE** Front wheels have to stay straight to avoid contact between bottom of fender and skid wheels guide.

3. Assisted by another person, move vehicle rearward out of the crate base.

**NOTICE** Always move vehicle rearward out of the crate base.

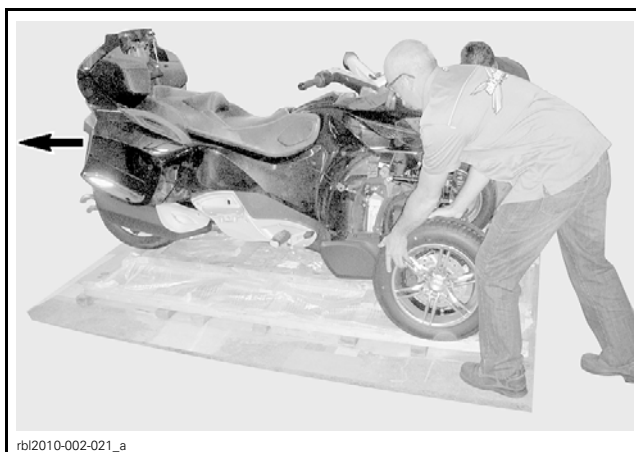

TYPICAL (RT MODEL SHOWN)

4. ► Clean rear brake disc using XPS BRAKES AND PARTS CLEANER (P/N 219 701 705) and a clean rag.

**NOTICE** A thin layer of anticorrosion treatment is present on the brake disc and must be removed before using the vehicle. Not conforming to this procedure may lead to a brake chattering squeaking and brake pad replacement would be necessary.

5. Apply parking brake.  
6. Lift the front of vehicle.  
7. Remove front wheels and clean brake discs using XPS BRAKES AND PARTS CLEANER (P/N 219 701 705) and a clean rag. ◀

## ► Wheel Installation ◀

1. ► Install front wheels on vehicle.  
2. Ensure that the rotation direction shown by the arrow is respected.

### ⚠ WARNING

The tires are only designed to rotate in one direction. Do not switch the left and right front wheels.

3. Tighten wheels lug nuts by hand.  
4. Lower vehicle.  
5. Torque wheels lug nuts.

### WHEEL LUG NUT TIGHTENING TORQUE

105 N•m (77 lbf•ft)

6. Install wheel caps (located inside front storage compartment). ◀

## ► Tires Pressure ◀

### ⚠ WARNING

► Low pressure may cause tire to deflate and rotate on wheel. Overpressure may burst the tire. Always follow recommended pressure.

**NOTICE** Always check pressure when tires are cold before using the vehicle.

NOTE: Tire pressure changes with temperature and altitude. Recheck pressure if one of these conditions has changed (e.g., significant weather change, driving in the mountains).

1. Inflate tires to the specified air pressure. Refer to the following table.

### COLD TIRE PRESSURE RECOMMENDATION

FRONT	REAR
103 kPa (15 PSI)	193 kPa (28 PSI) ◀

## PARTS TO BE INSTALLED

### Battery

NOTE: The battery is filled and serviced. However it needs to be fully charged prior to vehicle delivery. To perform charging of the battery you will need to removed battery from vehicle.



1. Battery location

1. Refer to the latest edition of *CAN-AM ROADSTER BATTERIES SERVICE BULLETIN* for proper activating, charging and maintenance procedures.
2. Open seat.
3. Remove LH and RH upper side panels.
  - 3.1 Cut locking tie retaining front screw and panel nut.

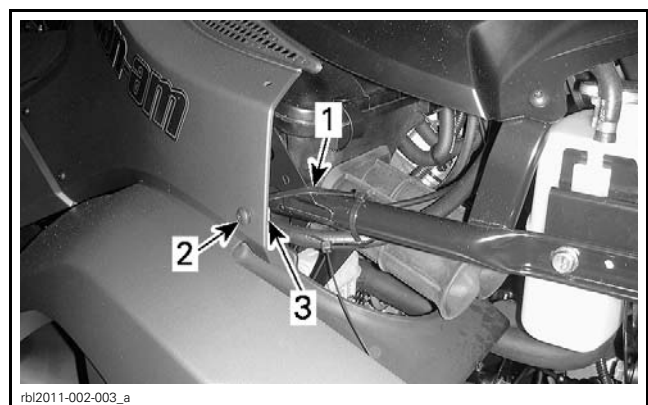

1. Locking tie  
2. Front panel screw  
3. Panel nut

- 3.2 Remove rear panel screws.

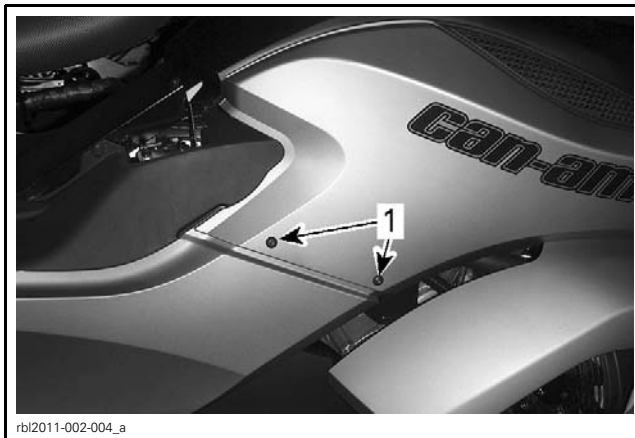

1. Rear panel screws

3.3 Install the previously removed panel nut on lateral bracket.



1. Panel nut

4. Remove LH rear panel.

4.1 Remove and keep plastic rivets located under seat.



1. Plastic rivets

4.2 Remove all retaining screws. Keep screws for reinstallation.

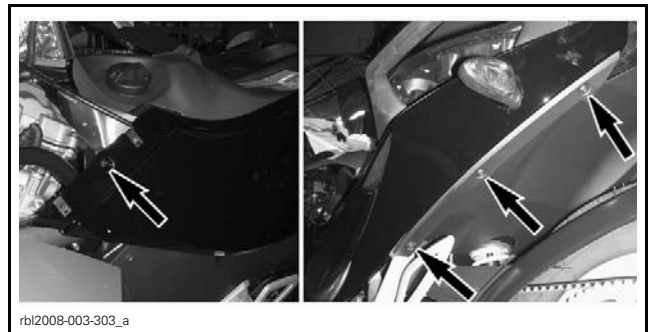

1. Retaining screws

4.3 Unplug turn signal connectors.

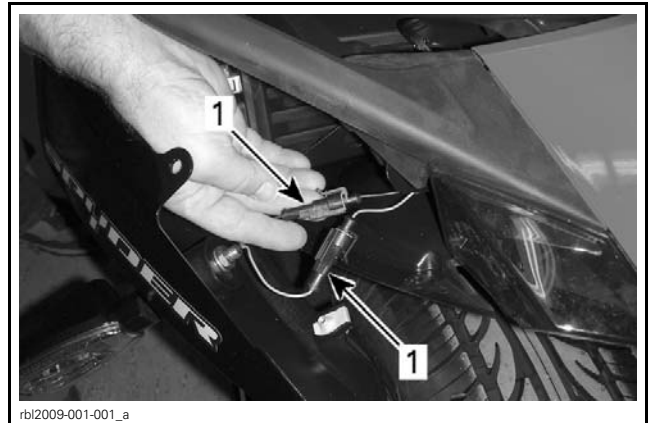

1. Turn signal connectors

5. Remove battery rubber strap.

6. Remove battery from vehicle.

7. Charge battery. Refer to *CAN-AM ROADSTER BATTERIES SERVICE BULLETIN*.

**CAUTION** Never charge or boost battery while installed on vehicle.

**NOTICE** It is of the utmost importance for the battery life span that the battery initial charging be performed.

8. Install charged battery on vehicle.

**NOTICE** Always charge battery before its installation on the vehicle.

9. Install battery screws on battery posts as per the following illustration.

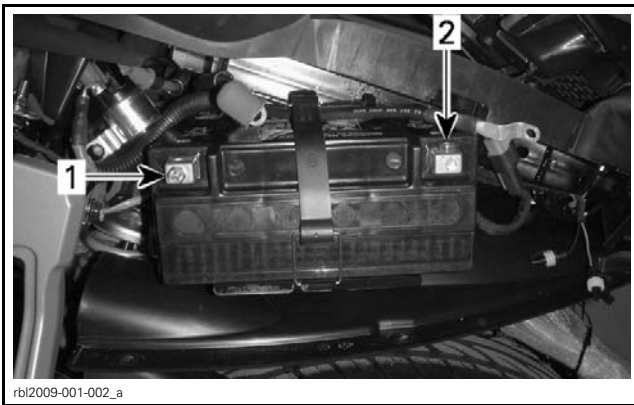

1. Positive post screw toward the side of vehicle
2. Negative post screw toward the top of vehicle

10. Secure battery in place with rubber strap.

**NOTICE** Make sure not to squeeze battery cables between vehicle components.

11. Connect RED (+) cable to positive battery post.

**⚠ WARNING**

Always connect RED (+) cable first and then BLACK (-) cable.

12. Connect BLACK (-) cable to negative battery post.

13. Apply DIELECTRIC GREASE (P/N 293 550 004) on battery posts.

14. Tighten battery post screws.

<b>BATTERY POST SCREW</b>
4 N•m (35 lb•in)

15. Close RED rubber boot cover.



TYPICAL

16. Reinstall the LH rear panel.

16.1 Plug turn signal connectors.

16.2 Secure panel with previously removed screws and plastic rivets.

**NOTICE** Do not overtighten screws. Any deformation on the panel around the screw head is an indication that it is too tight. Be careful not to damage the panels.

## Front Storage Compartment

1. Open front storage compartment cover.
2. Remove plastic rivets securing front panels.

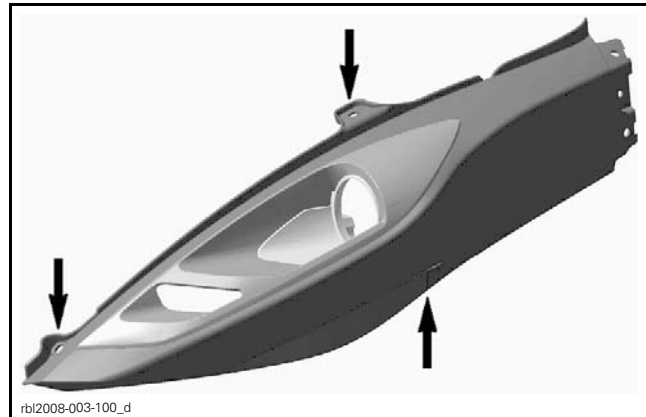

FRONT PANELS PLASTIC RIVETS LOCATION

3. Remove and discard bolts holding the bottom and the top sections of sub-crate.

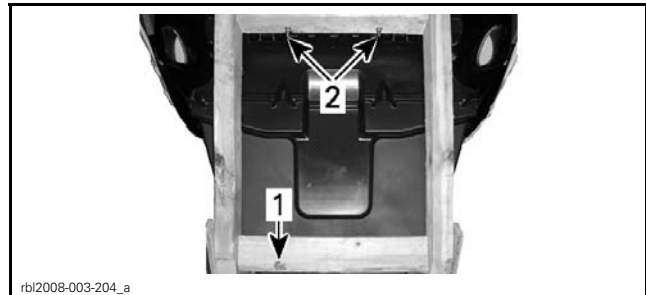

1. Lower retaining bolt
2. Upper retaining bolts

4. Cut locking ties securing horn and AAPTS harness to frame.

5. Free the front storage compartment cover cable.





1. Horn harness
2. APTS (Ambient Air Pressure and Temperature Sensor) harness
3. Front storage compartment cover cable
4. DLC (Diagnostic link cable connector)

### CE Models — Countries with Left-Hand Traffic

6. Before installing storage compartment, replace the low beam lights. Refer to *LOW BEAM LIGHT (CE MODELS)*.

### All Models

7. Assisted by another person, position front storage compartment into support slots of vehicle.

**NOTE:** Ensure that all cables are accessible prior to installing front storage compartment.

8. Secure the front storage compartment.
  - On TOP, use four M6 x 20 hexagonal flange screws
  - At the bottom, use two M6 x 12 hexagonal flange screws.

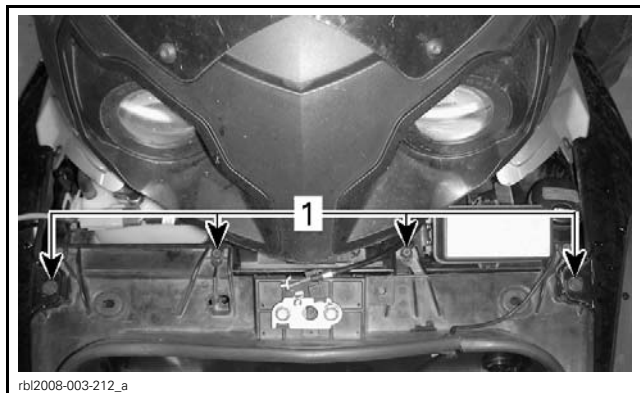

### TOP SCREWS

1. M6 X 20 hexagonal flange screws

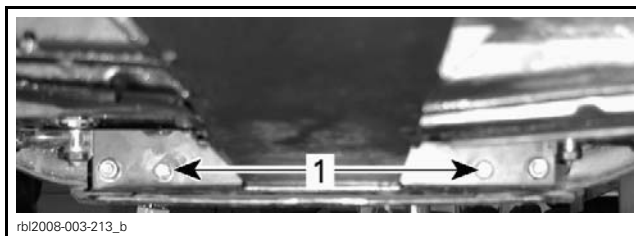

### BOTTOM SCREWS

1. M6 X 12 hexagonal flange screws

**NOTE:** Install all screws before tightening them.

FRONT STORAGE COMPARTMENT SCREW	TORQUE
M6 X 20 hexagonal flange screw	4.5 N•m (40 lbf•in)
M6 X 12 hexagonal flange screw	10 N•m (89 lbf•in)

## APTS (Ambient Air Pressure and Temperature Sensor) Installation

1. Add foam provided in the PDI kit to protect the tip of the APTS.
2. Secure it using M6 X 20 hexagonal flange screw and M6 caged nut (included in the PDI kit).

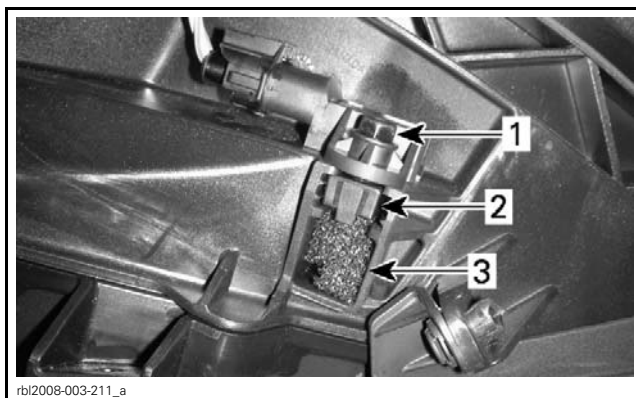

### APTS SENSOR INSTALLATION

1. M6 X 20 hexagonal flange screw
2. M6 caged nut
3. Foam

3. Route cable through retaining guide clips.

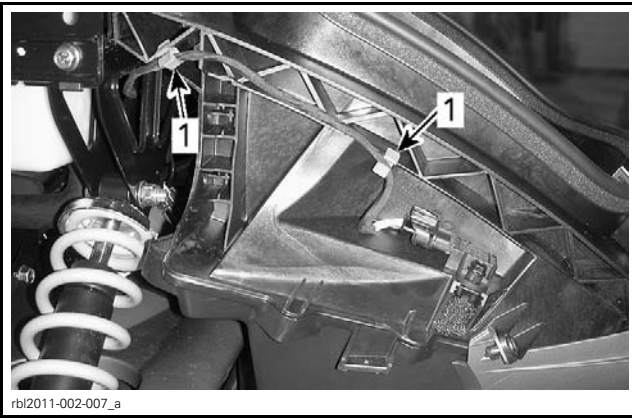

rbl2011-002-007\_a

1. Cable retaining clips

## Horn Connection

1. Connect horn connectors.
2. Route cable through the retaining guide clips.

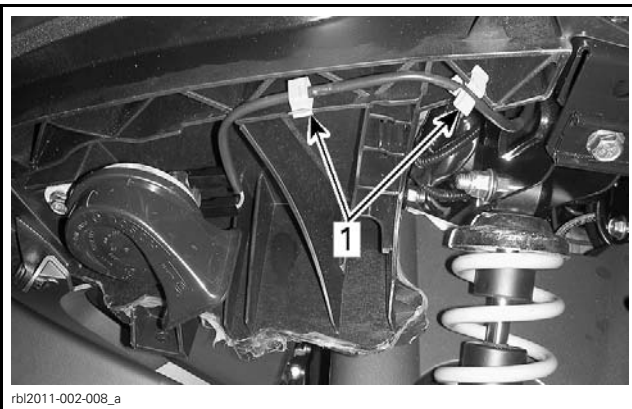

rbl2011-002-008\_a

1. Cable retaining clips

### CE Models

If necessary, remove horn from vehicle to ease connector installation.



rbl2009-001-003\_a

HORN RETAINING BOLT LOCATION

## Hood Latch Release Cable

1. Attach hood latch release cable into bracket.
2. Squeeze bracket legs to prevent cable from coming out using pliers.

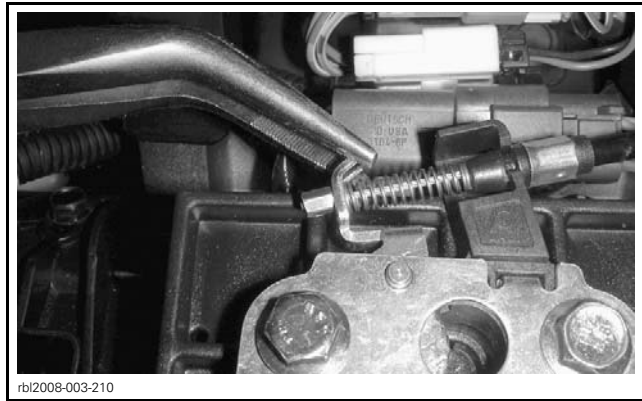

rbl2008-003-210

3. Verify if the front storage compartment cover opens and closes correctly.
4. Adjust cable if necessary.

**NOTICE** If the key does not turn easily, do not force it. Pull it out and reinsert.

## Diagnostic Link Cable (DLC)

1. Insert diagnostic link cable (DLC) into its housing on the front section of vehicle.

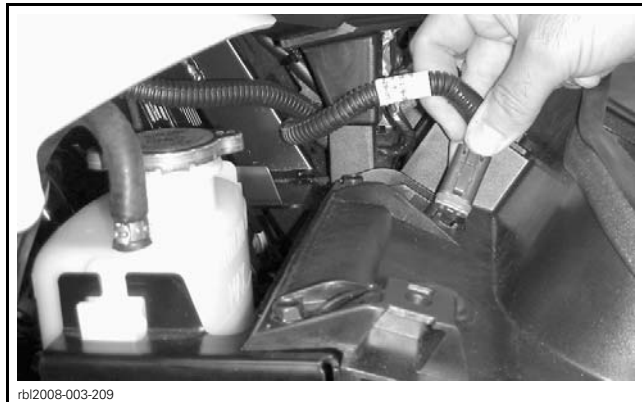

rbl2008-003-209

DLC CABLE INSERTION

## Mudguards

1. From inside mudguards, check for proper location (LH or RH side).

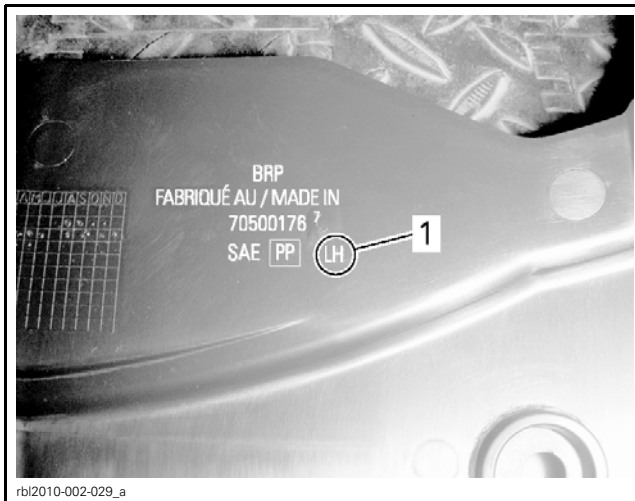

1. Installation side

2. Install two M6 panel nuts (from PDI kit) on each fender.

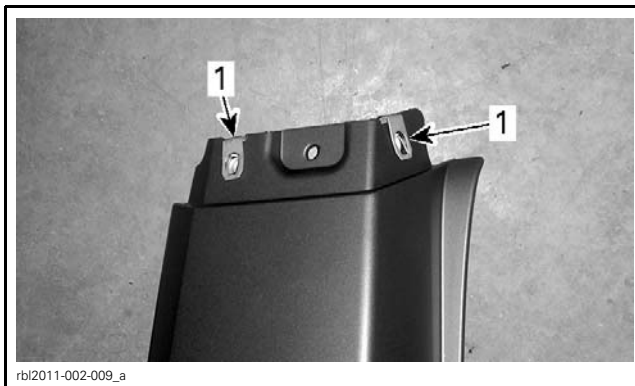

1. Panel nuts

3. Position mudguards on proper fender.
4. Secure mudguards using M6 x 20 Torx screws (from PDI kit).

MUDGUARD SCREW TIGHTENING TORQUE
3 N•m (27 lbf•in)

## Front Fenders

1. Cut locking tie that hold harness bracket on fender.

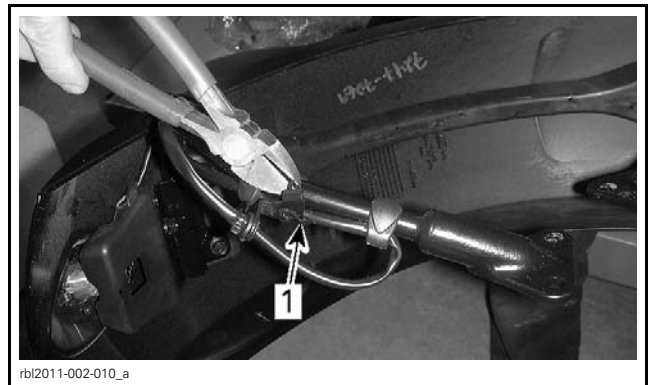

1. Locking tie

2. Position front fender on vehicle.



3. Route front brake hose on fender hook.

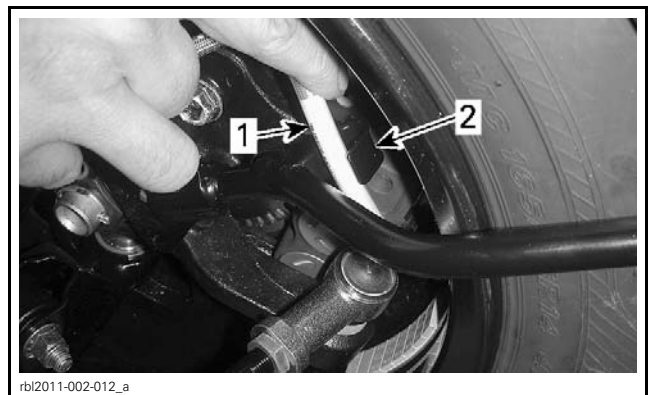

1. Brake hose
2. Fender hook

4. Properly insert cable grommet on harness bracket.

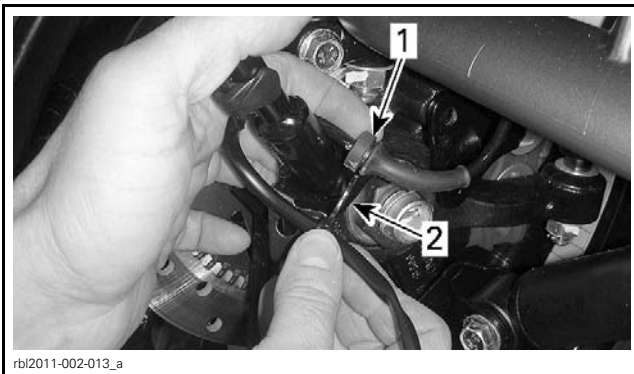

1. Cable grommet  
2. Harness bracket

5. Connect fender light connector.

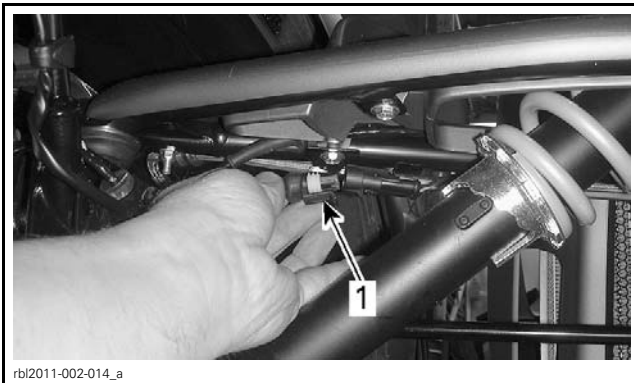

1. Fender light connector

6. Secure fender support on wheel hub.

6.1 Install the harness bracket over the fender support and secure them on wheel hub using a M8 x 35 hexagonal flange screw and a sleeve from the PDI kit.

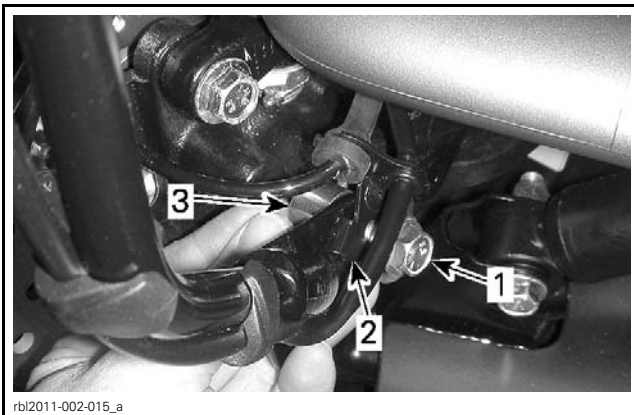

1. M8 x 35 hexagonal flange screws  
2. Sleeves (one hidden)  
3. Harness bracket

6.2 Install 3 other M8x 35 hexagonal flange screws and sleeves to complete the fender support installation.

<b>FENDER SUPPORT RETAINING SCREW</b>
24 N•m (18 lbf•ft)

7. Carry out the same procedure for the other side.

## Rear Fender

1. Remove packaging from rear fender.
2. Connect brake light connector.
3. Secure brake light harness inside the RH rear fender support using 3 locking ties (from PDI kit).

**NOTE:** Three locking tie retainers have been installed at factory to hold locking ties.

4. Install rear fender on vehicle using M6 X 20 Torx screws, plastic washers and M6 elastic flange nuts (included in PDI kit).

<b>REAR FENDER SCREW</b>
7 N•m (62 lbf•in)

5. Verify if brake light harness touches to rear tire. Reposition harness if required.

## Low Beam Light (CE Models)

### *Countries with Left-Hand Traffic*

The low-beam headlights must be changed for left-hand traffic countries to ensure proper low beam aiming.

1. Note the position of the adjustment screws on the installed headlight.

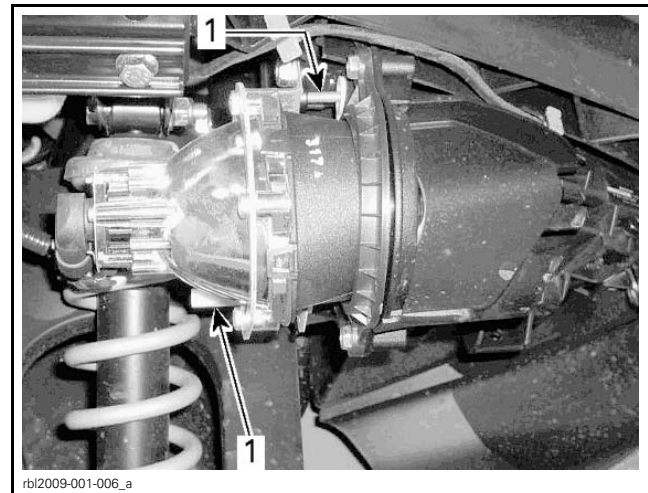

1. Adjustment screws

2. Remove retaining screws from headlight.

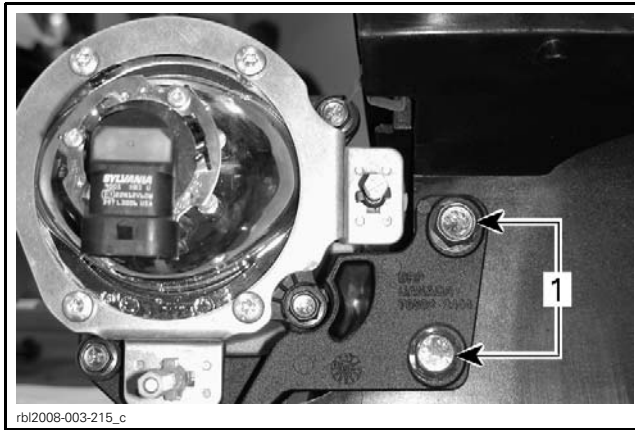

rbl2008-003-215\_c

1. Retaining screws

3. Pull out headlight.
4. Repeat the procedure for the remaining headlight.
5. Discard the removed headlights. Keep the screws for installation.
6. Install the new headlight into position.

**NOTE:** The left-hand traffic headlights can be recognized by the number 10895 on the lens rim (the right-hand traffic ones have the number 10894).

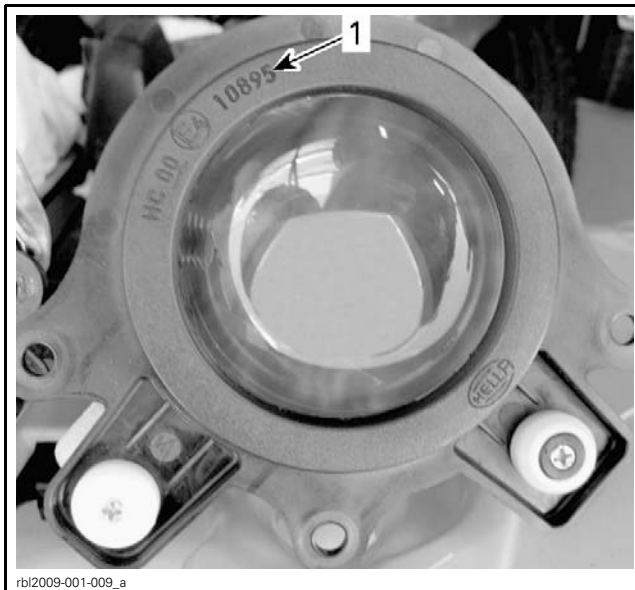

rbl2009-001-009\_a

1. Number 10895 for left-hand traffic headlights

7. Secure headlight with the original screws.
8. Torque screws to 11 N•m (97 lbf•in).
9. Set the adjusting screws to the same length as noted on the original headlights.

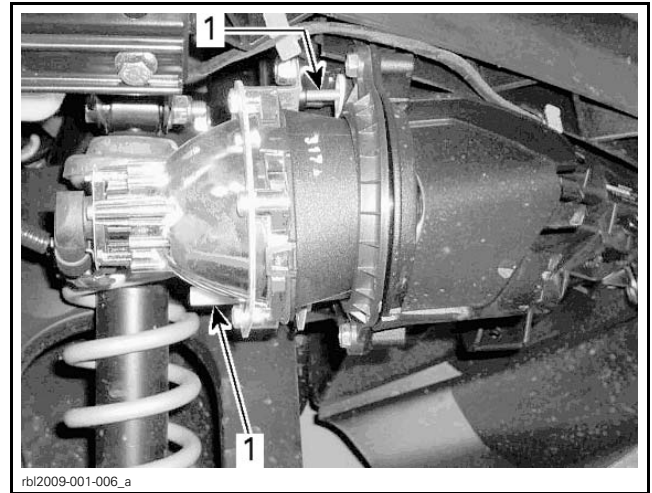

rbl2009-001-006\_a

1. Adjustment screws

10. Repeat the procedure for the remaining headlight.

### All CE Models

1. Connect wiring harness to low beam headlights.

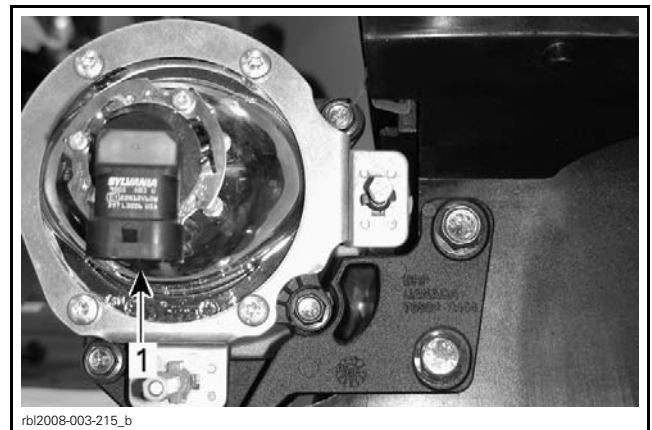

rbl2008-003-215\_b

1. Low beam headlight connector

2. Verify low beam headlights aiming. Refer to *LIGHTS* in *ADJUSTMENTS*.

## Hang Tag and Safety Labels

This vehicle comes with a hang tag and labels containing important safety information. The labels are considered permanent parts of the vehicle and should not be removed. Hang tag is to be removed by the owner only.

Any person who rides this vehicle should read and understand all the information given on hang tag and safety labels before riding.

Safety labels of several language can be chosen by customer, according to availability.

<p><b>⚠ WARNING</b></p> <p>The <b>Spyder</b> roadster is a different type of vehicle - it requires special skills and knowledge. Learn how the <b>Spyder</b> roadster is different.</p> <p>Read the operator's guide (in the front storage compartment) and watch the safety video.</p> <p><b>Complete</b> a training course (if available), <b>practice</b>, become proficient with the controls, and get a proper license. Refer to the Safety Card before riding.</p> <p><b>Always wear a helmet and riding gear.</b></p> <p>With this type of vehicle, riders are exposed to more road risks than in a car. Even skilled operators can be struck by other vehicles or lose control. This vehicle will not protect you in a crash.</p> <p><b>Handling limits and road conditions</b></p> <p>The Vehicle Stability System (VSS) cannot stop you from losing control, flipping over, or falling off if you exceed this vehicle's limits. Know the limits for different road conditions. Do not ride on ice, snow, or off road. Avoid puddles and running water. This type of vehicle can hydroplane on water and slip on gravel, dirt and sand covered roads. If you must go through these road conditions, slow down.</p> <p>This hangtag may only be removed by the customer.</p> <p style="text-align: right;">704601502C</p>	<p><b>⚠ AVERTISSEMENT</b></p> <p>Le roadster <b>Spyder</b> est un véhicule différent - sa conduite exige des habiletés et des connaissances particulières. Apprenez comment le roadster <b>Spyder</b> diffère des autres véhicules.</p> <p>Lisez le guide du conducteur (dans le compartiment de rangement avant) et visionnez la vidéo de sécurité.</p> <p><b>Suivez</b> une formation (si disponible), <b>exercez-vous</b>, apprenez à maîtriser les commandes et obtenez le permis approprié. Consultez la carte de sécurité avant de conduire le véhicule.</p> <p><b>Portez toujours un casque et des vêtements appropriés.</b></p> <p>Sur ce type de véhicule, les utilisateurs sont exposés à davantage de risques routiers qu'en automobile. Même un conducteur habile peut être frappé par un autre véhicule ou perdre le contrôle. Ce véhicule ne vous protégera pas en cas de collision.</p> <p><b>Limites de manoeuvrabilité et conditions routières</b></p> <p>Le système de stabilité du véhicule (VSS) ne peut pas vous empêcher de perdre le contrôle, de faire des tonneaux ou de tomber si vous dépassez les limites du véhicule. Apprenez à connaître ces limites dans différentes conditions routières. Ne conduisez pas sur la glace, sur la neige ou hors route. Évitez les flaques et les ruissellements d'eau. Ce type de véhicule peut faire de l'aquaplanage sur les chaussées détrempées et dérapier sur les routes recouvertes de gravier, de terre ou de sable. Si vous devez conduire dans ces conditions, ralentissez.</p> <p>Seul le client doit enlever cette étiquette.</p> <p style="text-align: right;">704601502C</p>
---	---

rmo2008-001-102

## Licence Plate Installation

NOTE: When a license plate needs to be installed or replaced, ensure to install two new damping pads (P/N 293 740 028) on plate to be installed.

1. Remove existing plate on vehicle (if applicable).
2. Peel off backing of new damping pads.

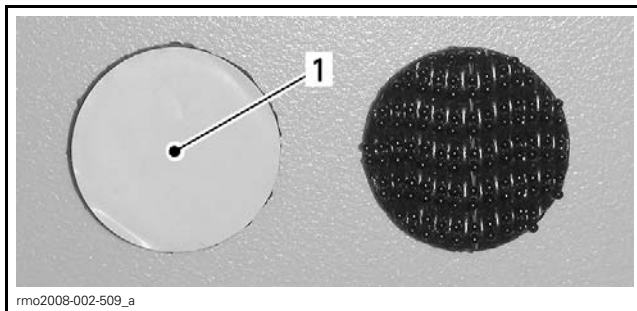

1. Damping pad backing

3. Position new damping pads over existing pads on vehicle plate support.

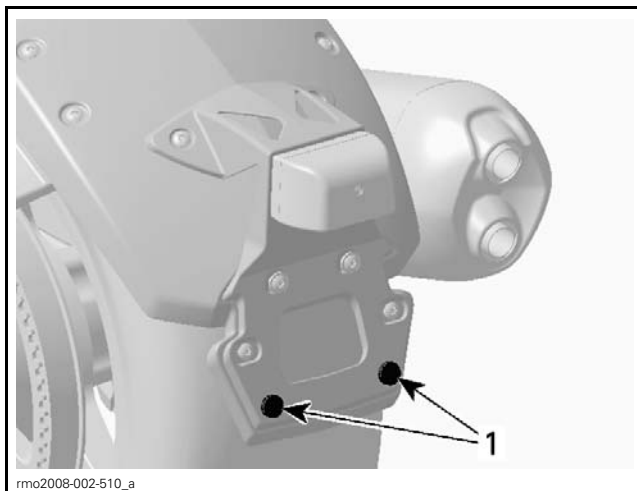

1. Damping pads

4. Secure upper portion of license plate on vehicle plate support using existing hardware.

5. Squeeze license plate and support together at each lower corner.

## Accessories Installation

1. Install accessories (if any) as per their installation instructions (included in each kit).
2. Install any other equipment required by law (if any).

## Vehicle Decals

1. Install decals on vehicle according to customer country language and local legislation.
2. Ensure that the new decals are installed at the same location and over the factory installed decals.

## FLUIDS

### General Guidelines

All fluids (except fuel) have already been filled at factory, it is only necessary to validate them. However, if refill is needed, refer to the appropriate *ROADSTER SHOP MANUAL* for the proper procedure.

### Fuel

1. Add a small amount of fuel in the fuel reservoir.



FUEL RESERVOIR

### Recommended Fuel

Use unleaded gasoline or oxygenated fuel containing no more than 10% ethanol or methanol or both. The gasoline used must have the following minimum octane rating:

MINIMUM OCTANE RATING	
North America	87 (R+M)/2
Outside North America	92 RON

**⚠ WARNING**

Never top off the fuel tank before placing the vehicle in a warm area. As temperature increases, fuel expands and may overflow. Fuel is flammable and explosive under certain conditions. Always wipe off any fuel or oil spillage from the vehicle.

**NOTICE** Other fuel can degrade vehicle performance and damage critical parts in the fuel system and engine.

**NOTICE** Never mix oil with fuel these vehicles are equipped with a 4-stroke engine.

**Clutch Fluid (SM5 Model)**

**Recommended Clutch Fluid**

Use DOT 4 brake fluid from a sealed container. An opened container may be contaminated or may have absorbed moisture from the air.

**Clutch Fluid Level Verification**

**NOTE:** The clutch fluid reservoir is located on the left side of handlebar.

1. Park the vehicle on a firm, level surface.
2. Look inside the window on top of the reservoir to see whether the fluid is visible.

**NOTE:** If necessary, use a flashlight or shake the handlebars.

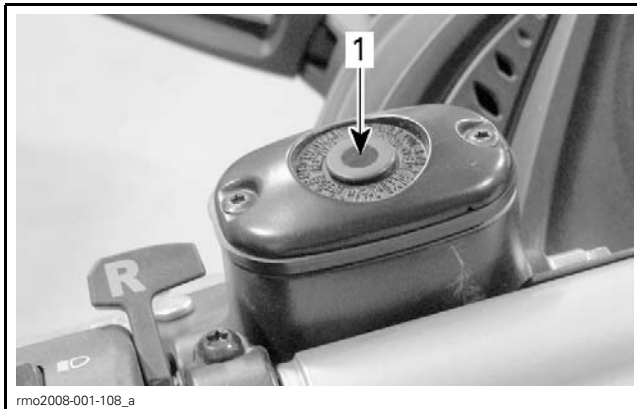

1. Clutch fluid reservoir window

3. If fluid is not visible, add recommended clutch fluid.

**Engine Coolant**

**⚠ WARNING**

When opening the reservoir, the coolant can be very hot and spray out if the engine is hot. In order to avoid getting burned, check coolant level when engine is cold.

**Recommended Coolant**

The cooling system must be filled with distilled water and antifreeze solution (50% distilled water, 50% antifreeze).

For best performance, use BRP PREMIXED COOLANT (P/N 219 700 362).

**Coolant Level Verification**

1. Park vehicle on a firm level surface.
2. Check coolant level on the right hand side.
3. Ensure that coolant is visible without exceeding the MAX. level mark.

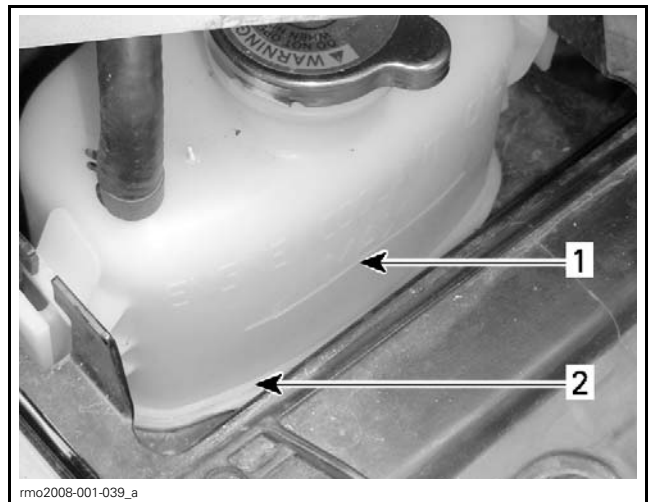

1. Coolant MAX. level mark
2. Coolant must be visible

4. If required, add recommended coolant until it is visible in the reservoir without exceeding the MAX. level mark. Use a funnel to avoid spillage. Do not overfill.

**Brake Fluid**

**⚠ WARNING**

Avoid contact of brake fluid with skin or eyes because it may cause severe burns. In case of contact with the skin, wash thoroughly. In case of contact with the eyes, immediately rinse with plenty of water for at least 10 minutes and then consult a doctor immediately.

**NOTICE** Do not overfill brake fluid reservoir.

## Recommended Fluid

Use only DOT 4 brake fluid from a sealed container. An opened container may be contaminated or may have absorbed moisture from the air.

**NOTICE** To avoid serious damage to the braking system, do not use non-recommended fluids. Brake fluid can damage plastic and painted surface. Handle with care.

## Brake Fluid Level Verification

1. Park vehicle on a firm level surface.



1. Brake fluid reservoir

2. Remove reservoir caps.
3. Ensure diaphragms under cap are not descended. If they are, return them to normal position.
4. Check brake fluid level in both reservoirs.
5. Ensure that fluid is above the MIN. mark.

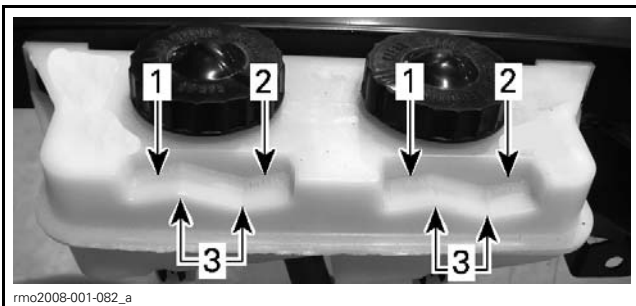

1. Brake fluid MAX. level mark  
 2. Brake fluid MIN. level mark  
 3. Operating range

6. If necessary, add recommended brake fluid.
7. Immediately wipe out spills if necessary.
8. Reinstall both reservoir caps.
9. Close seat and ensure it is fully latched.

## Engine Oil

### Recommended Engine Oil

**NOTE:** For SM5 models, the same oil lubricates the engine, the gearbox and the clutch.

**NOTE:** For SE5 models, the same oil lubricates the engine, the gearbox, the clutch and the HCM (hydraulic control module).

Use XPS SYNTHETIC BLEND OIL (SUMMER GRADE) (P/N 293 600 121).

If not available, use a 5W40 semi-synthetic (minimum) or synthetic **motorcycle oil** meeting the requirements for API service SL, SJ, SH or SG classification. Always check the API service label on the oil container.

**NOTICE** To avoid damaging the clutch, do not use a motor oil meeting the API service SM or ILSAC GF-4 classification. Clutch slippage will occur. Motorcycle oils designed for use with a wet-clutch are the best alternative.

### Vehicle Preparation for Engine Oil Level Verification

1. Remove LH middle side panel using clips.

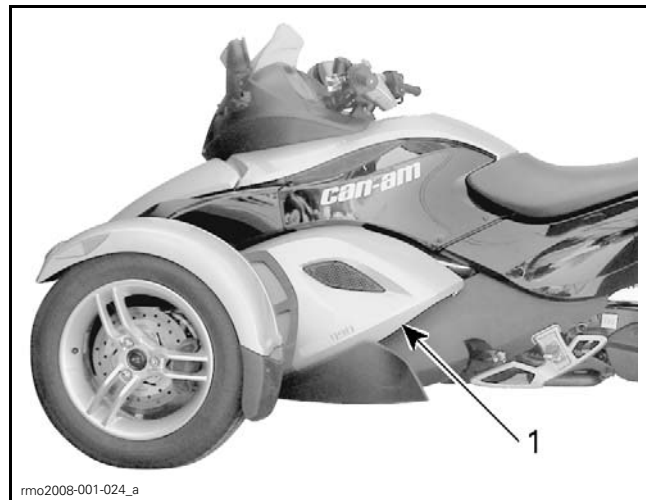

1. Middle side panel





1. Middle side panel clips

2. Press down panel top edge with both hands and pull out.

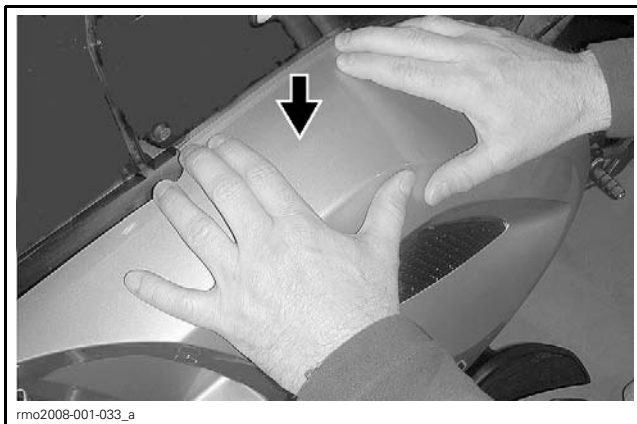

3. Remove middle side panel from vehicle by lifting it.

### Oil Level Verification Procedure

**⚠ WARNING**

Before starting vehicle ensure vehicle in a well ventilated area or is outside. Smoke will come from the engine for 10 minutes as the anti corrosion coating on the exhaust system and engine burns off.

**NOTICE** For an accurate oil level reading, it is necessary to ride vehicle for 5–7 minutes to ensure that the engine is at its operating temperature. If oil level is verified when vehicle is not at operating temperature, oil level must be between lower and upper marks on dipstick.

**NOTICE** Never add oil in the engine if the verification is performed when the engine is cold.

1. With the engine already at normal operating temperature, start engine and let it run for at least 30 seconds.

**NOTE:** Running engine for at least 30 seconds allows the suction oil pump to drain the oil from the engine crankcase back into the oil tank. Not carrying out this step could result in overfilling the engine oil.

2. Stop engine.
3. Unscrew and remove oil dipstick.

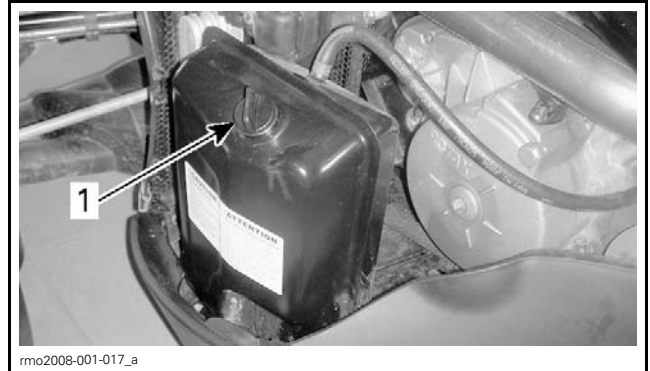

1. Oil dipstick

4. Wipe off the dipstick.
5. Reinsert and **completely screw in** the dipstick to assure an accurate reading.
6. Unscrew and remove dipstick again.
7. Check oil level on dipstick. It should be near or equal to the upper mark.

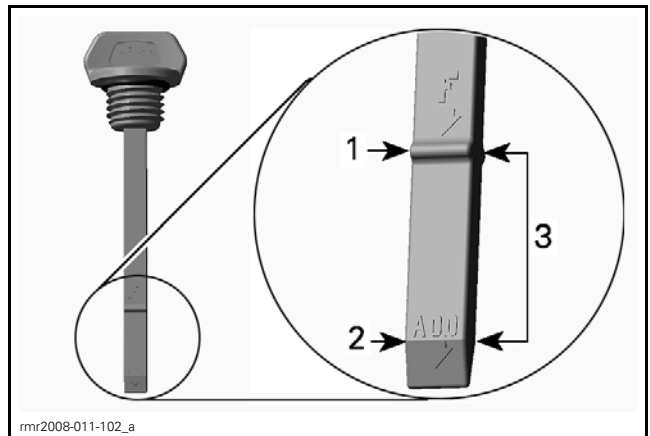

1. Full
2. Add
3. Operating range

If Oil Level is at or Near Upper Mark:

- Properly insert and tighten dipstick.
- Install the LH middle side panel.

If Oil Level is Under Operating Range:

- Add a small amount of recommended oil.
- Repeat the previous steps until oil level reaches the dipstick's upper (F) mark. **Do not overfill.**
- Properly insert and tighten dipstick.
- Install the LH middle side panel.

### Vehicle Parts Reinstallation

1. Install LH middle panel.
2. Insert the middle side panel tabs into the lower side panel slots.

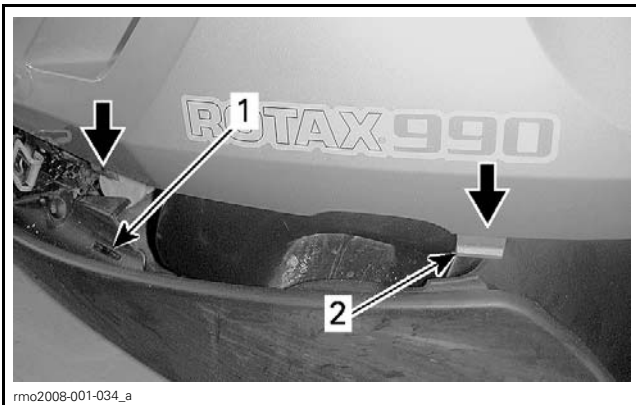

1. Lower side panel slot
2. Middle side panel tab

3. Press down panel top edge with both hands and push in.
4. Ensure that lower tabs remain in slots while pressing.



1. Press down top edge
2. Push top edge under top side panel edge

5. Secure panel by pushing and turning each clip clockwise (1 turn).



rmo2008-001-035\_a

**NOTE:** Clip is properly fixed when a small amount of force is required while turning clip to its maximum rotation. Clip is not properly fixed when it is loose while turning.

## BODY PARTS INSTALLATION

**NOTICE** Do not overtighten screws. Any deformation on the panel around the screw is an indication that it is too tight. Be careful not to damage the panels.

### Front Panels

1. Install M6 panel nuts on front panels (included in the PDI kit)
2. Install front panels on vehicle.



rb12009-001-004\_a

**RH FRONT PANEL SHOWN**

1. Front M6 panel nuts

3. Secure front panels. Use screw removed during front panel removal.

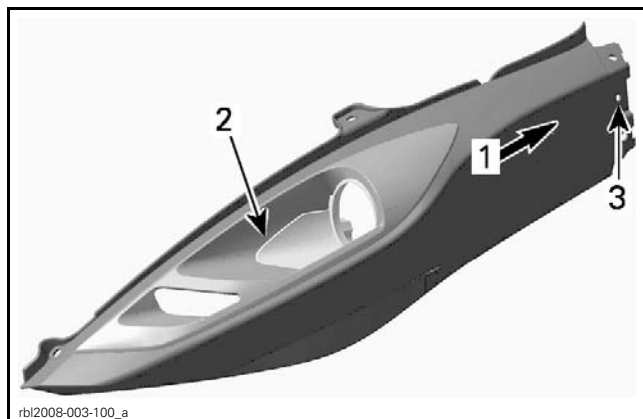

rb12008-003-100\_a

**CE MODEL SHOWN**

1. Move side air deflector backward
2. Area that must be fit
3. Front panel screw

**NOTE:** On CE models, move side air deflector backward for a best fit.

4. Install plastic rivets.

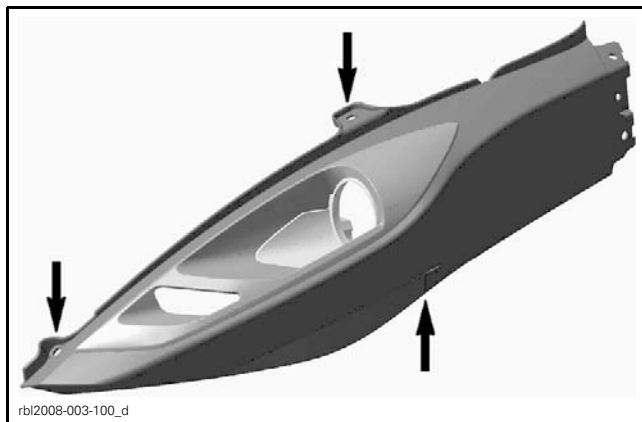

FRONT PANELS PLASTIC RIVETS LOCATION

## Upper Side Panels

1. Install plastic washers on M6 x 20 Torx screws (included in the PDI kit).
2. Install upper side panels as the reverse of the removal procedure.

## LH Rear Panel

Ensure that LH rear panel is reinstalled on vehicle.

## Service Cover

Install service cover on the front of vehicle (included in front service compartment).

# ADJUSTMENTS

## Guidelines

All adjustments have already been performed at factory. It is only necessary to validate them. However, if readjustment is needed, refer to the appropriate *ROADSTER SHOP MANUAL* for the proper procedure.

## Drive Belt

**NOTICE** Always verify drive belt tension with all parts at room temperature and the rear wheel lifted off the ground.

1. Place vehicle on a level surface.

NOTE: The area must be protected against wind and must have a very low background noise.

2. Set transmission to NEUTRAL.
3. Lift rear of vehicle by the frame until rear wheel is off the ground.

**NOTICE** Do not lift under rear shock absorber. Always lift by the frame. Refer to illustration.



TYPICAL - LIFT BY THE FRAME

4. To check the drive belt tension use the BELT TENSION METER (P/N 529 036 115).



5. Enter the following specifications to program the meter.

MASS	WIDTH	SPAN
8.4 g/m	28.0 mm/R	1028 mm



SONIC TENSION METER DISPLAY

NOTE: Refer to the manufacturer's instructions to set the informations into the device.

6. Turn rear wheel to align a wheel spoke with the swing arm.



rmr2008-031-003

TYPICAL - SWING ARM ALIGNS WITH A SPOKE

7. Position the sensor behind the LH passenger footrest and hold the sonic tension meter sensor approximately 1 cm (1/2 in) from belt or closer without touching the belt.



rbs2010-006-002

SPYDER GS/RS

8. Tap the belt to make the belt vibrate and note the measurement.

9. Repeat step 8.

NOTE: The second value should be within  $\pm 25N$ . If not, repeat measurements until tolerance is met.

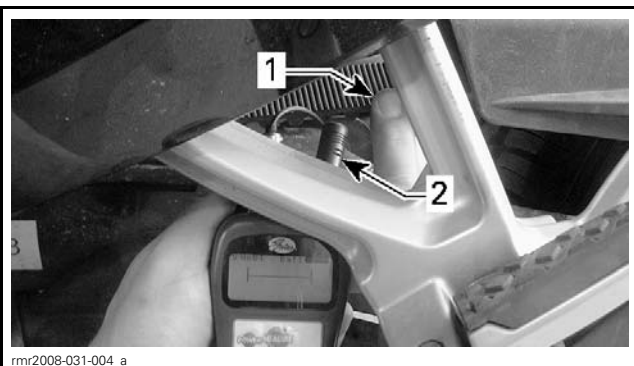

rmr2008-031-004\_a

TYPICAL - SPYDER RS SHOWN

1. Tap the belt
2. Sonic tension meter sensor

10. Repeat steps 6 to 9 for the 2 remaining wheel spokes.

The average of the 3 obtained values (at the 3 spokes) must be within the following range:

**DRIVE BELT TENSION  
(PARTS AT ROOM TEMPERATURE AND  
REAR WHEEL LIFTED)**

450N  $\pm$  150N

If the tension of drive belt is out of specification, adjust drive belt as per *DRIVE BELT TENSION ADJUSTMENT*. Refer to *DRIVE SYSTEM* subsection in the proper *CAN-AM ROADSTER SHOP MANUAL*.

**Clutch Lever**

NOTE: The distance between the clutch lever and handgrip can be adjusted from position 1 (greatest distance) to position 4 (smallest distance).

1. Adjust the clutch lever as per the owner's preference.
  - 1.1 Push the clutch lever forward to release the adjuster dial. Hold in position.
  - 1.2 Turn the adjuster dial to the desired position aligning the dial number with the dot on the lever.
  - 1.3 Release the clutch lever.

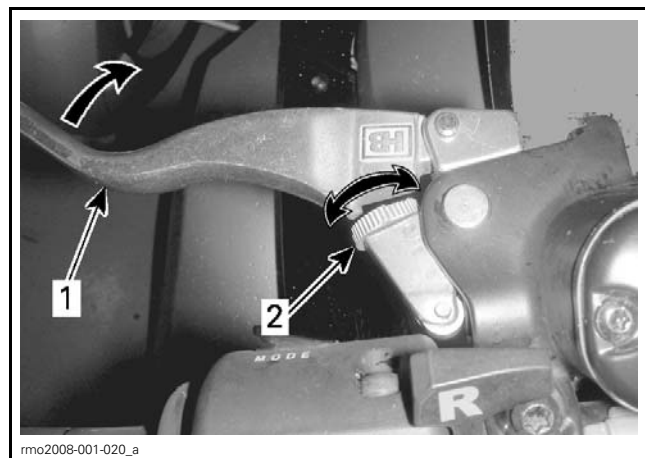

rmo2008-001-020\_a

CLUTCH LEVER ADJUSTMENT

1. Clutch lever
2. Adjuster dial

**Suspension**

**⚠ WARNING**

Left and right adjusting cams must always be set at the same position. Never adjust one adjusting cam only. Uneven adjustment can cause poor handling and loss of stability, which could lead to an accident.

## Front Suspension

**NOTICE** Before adjusting suspension, lift the front of vehicle using a jack to extend the suspension. This will ease turning the adjustment cam and will prevent a potential breakage of the adjustment plate.

1. Adjust the spring preload as per the owner's preference.
  - 1.1 Place the vehicle on a level surface.
  - 1.2 Engage the parking brake.
  - 1.3 Adjust the spring preload by turning the cam with the adjusting wrench (stored in the tool kit).
2. Refer to the following table for proper adjustment.

RECOMMENDED FRONT SHOCK ADJUSTMENT	
LOAD	CAM POSITION
68 kg (150 lb) rider	2
91 kg (200 lb) rider	3
68 kg (150 lb) rider with cargo	3
91 kg (200 lb) rider with cargo	4
Rider with passenger and cargo	5

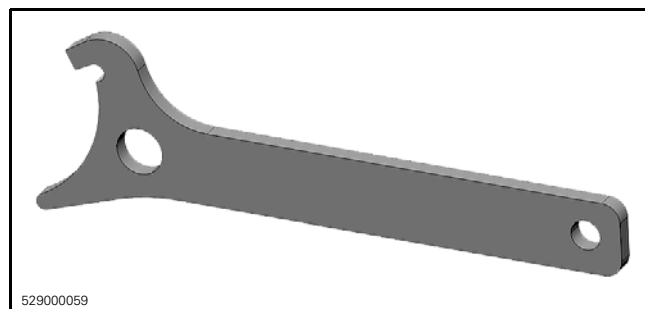

529000059  
FRONT SUSPENSION ADJUSTING WRENCH



rmr2008-029-003  
FRONT SUSPENSION ADJUSTMENT LOCATION

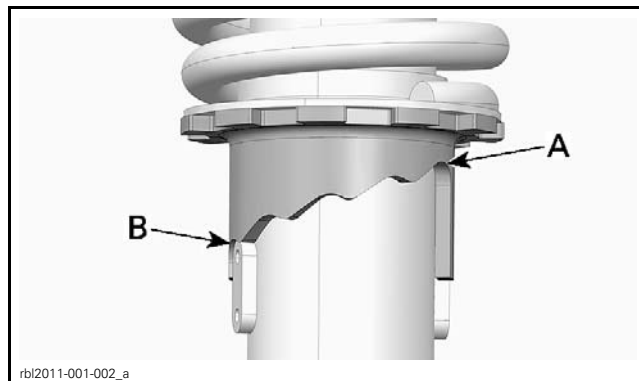

rb12011-001-002\_a  
ADJUSTMENT CAM

1. Softest adjustment (position 1)
2. Hardest adjustment (position 5)

## Rear Suspension

1. Adjust the spring preload as per the owner's preference.
2. Refer to the following table for proper adjustment.

RECOMMENDED REAR SHOCK ADJUSTMENT	
LOAD	CAM POSITION
68 kg (150 lb) rider	1
91 kg (200 lb) rider	3
With passenger rider	7

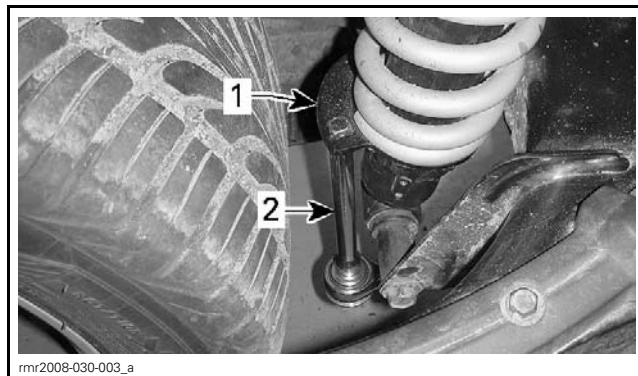

rmr2008-030-003\_a  
REAR SUSPENSION ADJUSTMENT LOCATION

1. Cam adjuster
2. Ratchet with extension

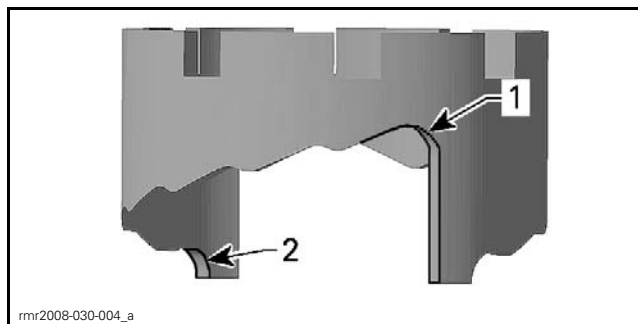

rmr2008-030-004\_a  
ADJUSTMENT CAM

1. Softest adjustment (position 1)
2. Hardest adjustment (position 7)

## ► Lights ◀

### ► Headlight Aiming Adjustment ◀

#### ► North American Models

Position the vehicle in front of a test surface as shown.

Have a person of at least 91 kg (200 lb) taking place on the driver's seat.

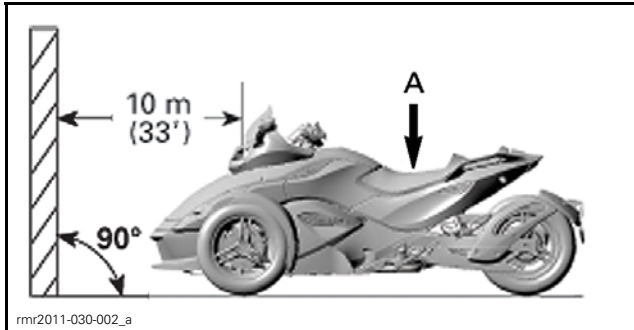

rmo2011-030-002\_a

A. 91 kg (200 lb)

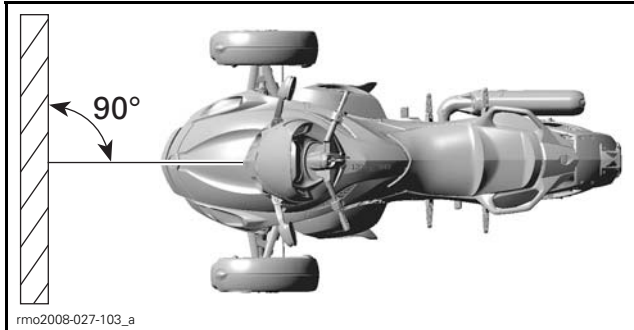

rmo2008-027-103\_a

Trace 2 lines parallel to the ground on the test surface as follows:

LINES ON THE TEST SURFACE	
Line A	<u>700 mm (27-1/2 in) above ground</u>
Line B	<u>610 mm (24 in) above ground</u>

Have a person of approximately the same weight as the driver taking place on the vehicle.

Select low beam.

Beam aiming is correct when the focus point of headlight reflection is between marks.

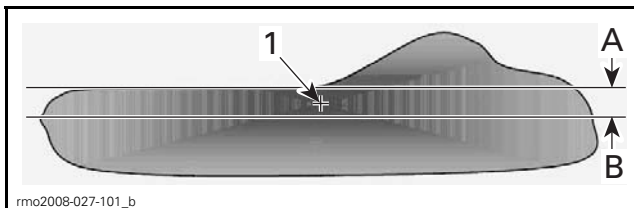

rmo2008-027-101\_b

HEADLIGHT REFLECTION ON TEST SURFACE

1. Focus point

A. 700 mm (27-1/2 in) above ground

B. 610 mm (24 in) above ground

Turn adjustment screws to adjust beam height. Adjust both headlights evenly.

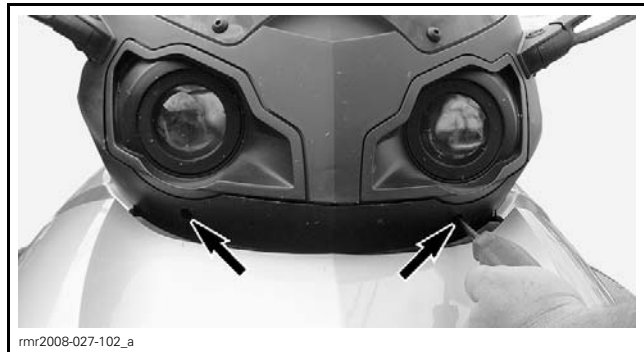

rmo2008-027-102\_a

ADJUSTMENT SCREWS

#### European Models

Position the vehicle in front of a test surface as shown.

Have a person of at least 91 kg (200 lb) taking place on the driver's seat.

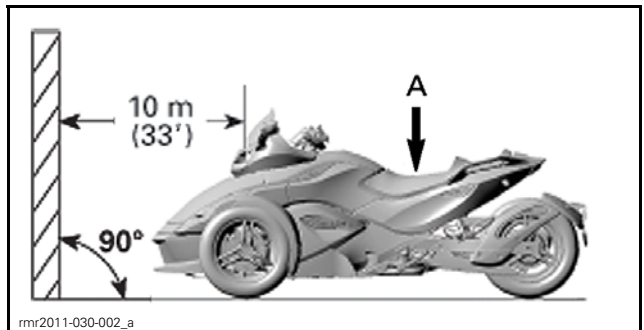

rmo2011-030-002\_a

A. 91 kg (200 lb)

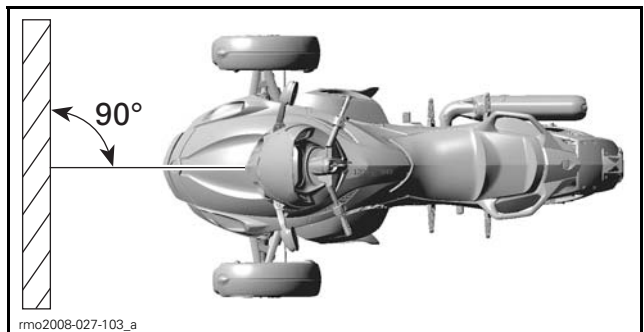

rmo2008-027-103\_a

Trace 4 lines parallel to the ground on the test surface as follows:

LINES ON THE TEST SURFACE	
Line A	<u>828 mm (32-19/32 in) above ground</u>
Line B	<u>738 mm (29-1/16 in) above ground</u>
Line C	<u>464 mm (18-9/32 in) above ground</u>
Line D	<u>374 mm (14-23/32 in) above ground</u>

Have a person of approximately the same weight as the driver taking place on the vehicle.

Select high beam.

Beam aiming is correct when the focus point of headlight reflection is between upper marks.

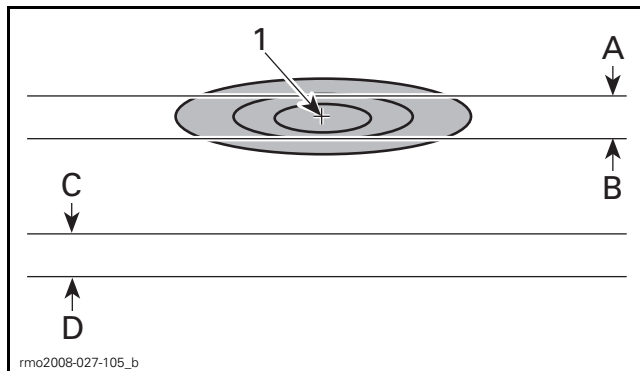

**HEADLIGHT REFLECTION ON TEST SURFACE — HIGH BEAM**

1. *Focus point*

A. *828 mm (32-19/32 in) above ground*

B. *738 mm (29-1/16 in) above ground*

C. *464 mm (18-9/32 in) above ground*

D. *374 mm (14-23/32 in) above ground*

Select low beam.

Beam aiming is correct when the focus point of headlight reflection is between lower marks.

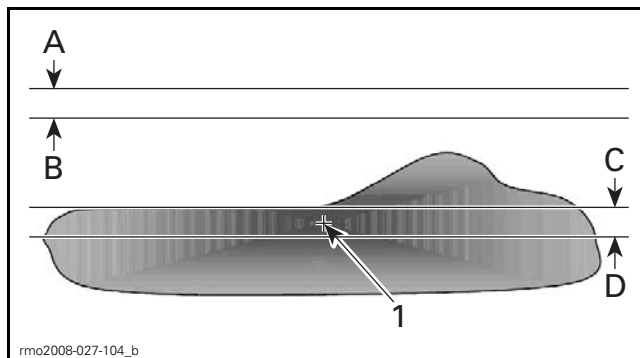

**RH TRAFFIC HEADLIGHT REFLECTION ON TEST SURFACE — LOW BEAM**

1. *Focus point*

A. *828 mm (32-19/32 in) above ground*

B. *738 mm (29-1/16 in) above ground*

C. *464 mm (18-9/32 in) above ground*

D. *374 mm (14-23/32 in) above ground*

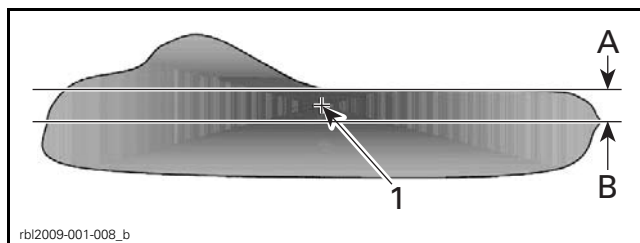

**LH TRAFFIC HEADLIGHT REFLECTION ON TEST SURFACE — LOW BEAM**

1. *Focus point*

A. *464 mm (18-9/32 in) above ground*

B. *374 mm (14-23/32 in) above ground*

NOTE: For LH traffic country application, low beam headlights must have been replaced as described in this predelivery bulletin.

**High Beam**

Turn adjustment screws to adjust beam height. Adjust both headlights evenly.

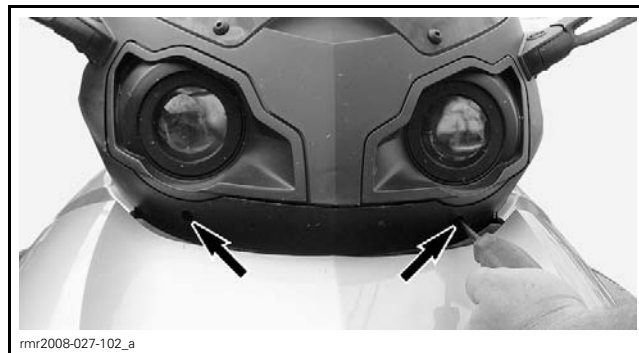

**ADJUSTMENT SCREWS**

**Low Beam**

Insert a long Phillips screwdriver into air duct to reach the adjustment screws.

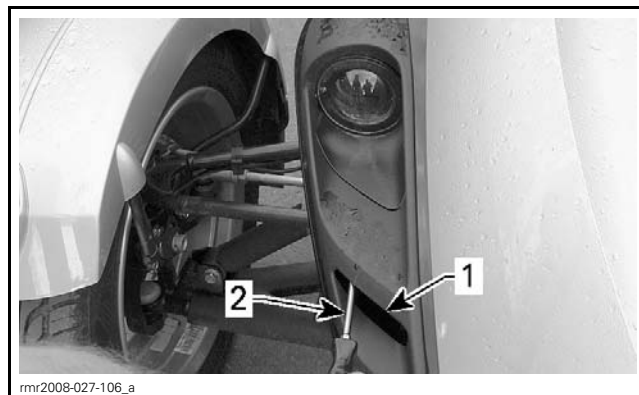

1. *Air duct*  
2. *Screwdriver*

Turn adjustment screws to adjust beam height. Adjust both headlights evenly. ◀



**B.U.D.S. Programming**

Always use the latest B.U.D.S. version on your shop computer. At time of printing, the latest B.U.D.S. version is P2.3.29. It is available from the following web site:

WWW.BOSSWEB.BRP.COM

**NOTICE** During data transfer, make sure that:

- Voltage (12V) remains stable before starting update. Charge the battery or use a power pack to have enough power.
- Although screen "freezes" for a while, remain on the B.U.D.S. because update still continues
- Never disconnect any cable while updating ECM.

<b>MANDATORY TOOLS</b>	
A personal computer (laptop or desktop)	
MPI-2 INTERFACE CARD (P/N 529 036 018)	
MPI-2 DIAGNOSTIC CABLE (P/N 710 000 851)	
<b>OPTIONAL TOOL</b>	
Extension cable available at electronic retail outlets. Do not exceed 7.5 m (25 ft)	

**NOTE:** B.U.D.S. is not used to program the hard keys (included keys are ready to use).

Use B.U.D.S. to

- Enter Customer's Name
- Reset Trip Hours and Trip Distances
- Reset Last Service
- Set Speedometer Units
- Set Cluster Language
- Check fault codes (if any).

**Connecting PC to Vehicle**

1. Remove service cover from vehicle.
2. Connect the PC to vehicle. Refer to the latest edition of *CAN-AM ROADSTER B.U.D.S. SOFTWARE AND COMMUNICATION TOOLS* for the proper connecting procedure.
3. Ensure that the status bar shows the proper protocol and proper ECU number. Refer to the following table.

MODEL	PROTOCOL	ECU NUMBER
SM5	KW2000 500K	4
SE5	KW2000 500K	5

4. Press READ DATA button from the tool bar to initiate communication with the vehicle.

**Entering Customer's Name**

**NOTE:** When starting the vehicle, the multifunction display will show the name of the customer; for example: "HI JOHN SMITH". If the customer's name is not programmed, only "HI" will be visible when turning the vehicle ON.

1. Click on the VEHICLE tab to open the vehicle information page.

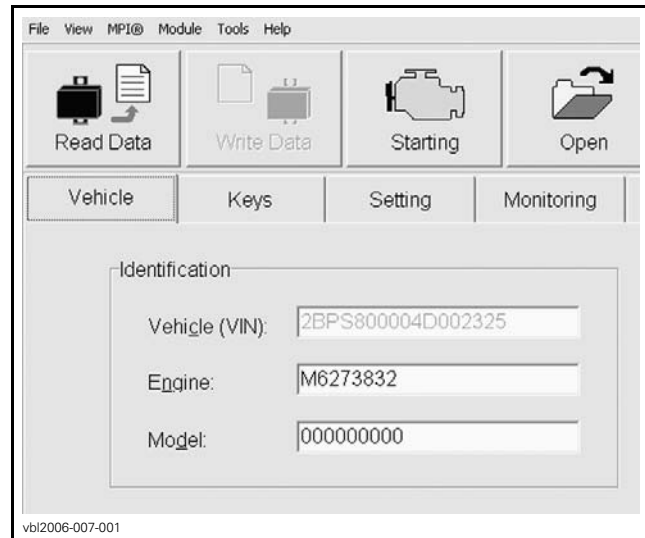

2. Type the name of the customer.



3. Click on WRITE DATA to save the information in the vehicle ECM.

**NOTE:** After you are finished typing the name, B.U.D.S. automatically updates the Delivery Date on the screen.

**Resetting Trip Hours and Trip Distances**

1. Ensure that the VEHICLE tab is selected.
2. Click on the RESET TRIP buttons to reset the information.



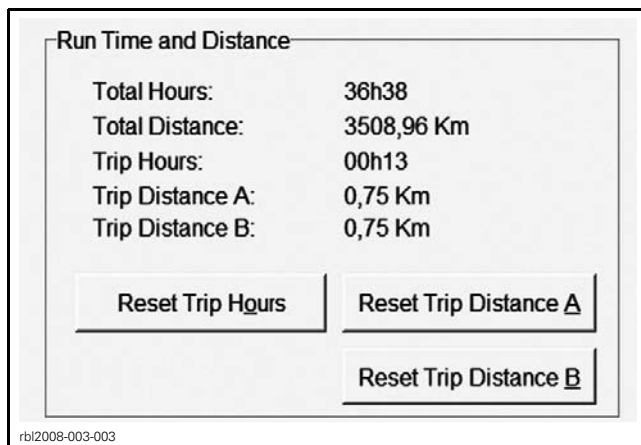

NOTE: It can also be done directly on the info-center, using the selector button.

### Resetting Last Service

1. Click on the RESET SERVICE button to reset the informations.

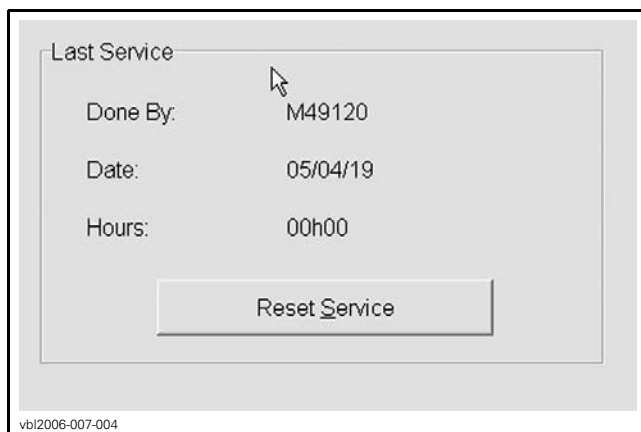

NOTE: After each maintenance service, Last Service should be reset to keep a good track of vehicle service history.

### Speedometer Units

NOTE: The speedometer is factory preset in miles but it is possible to change it to kilometer reading. Any unit modification is applied to the speedometer, odometer and trip meter.

1. Select the SETTING tab in B.U.D.S.
2. Select CLUSTER page.
3. Select Miles or Kilometers from the CLUSTER SCALE section.

NOTE: No data will be lost when changing this setting.

### Cluster Language (chosen by customer according to availability)

NOTE: The default language displayed in the multi-function gauge is English. To change the language displayed in the multifunction gauge.

1. Select SETTING tab at the top of the page.
2. Select CLUSTER tab at the bottom of the page.
3. Select desired language in the LANGUAGE field.

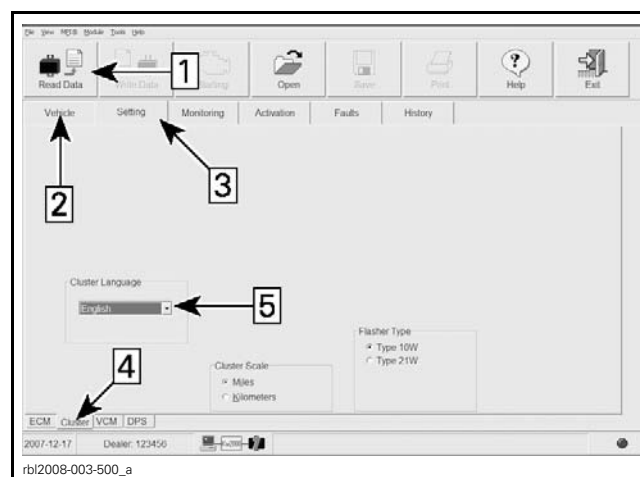

1. Read data button
2. Vehicle tab
3. Setting tab
4. Cluster tab
5. Language field

NOTE: If the language selection is not available, the gauge may not have the latest software version available.

### Ending a B.U.D.S. Session

**NOTICE** After a problem has been solved, ensure to clear the fault(s). This will properly reset the appropriate counter(s).

1. Click on FAULT tab and check if there are active faults. If so, service vehicle then clear the faults in B.U.D.S.
2. Click on WRITE DATA button to transfer new settings and information to the modules.



WRITE DATA BUTTON

3. Click on EXIT button (right most) to end session.
4. Reinstall DCL connector into its housing.
5. Reinstall service cover on vehicle.

## Cluster Units and Clock Units Setting

NOTE: Speed can be displayed in kilometers (Km/h) or miles (MPH) per hour.

1. Turn ignition switch to ON.
2. Press the M button to stop the initial scrolling message.
3. Press and hold the S button for three seconds.
  - A scrolling message appears on the main digital display:
4. PUSH **\_M\_** TO SELECT KM, **\_S\_** TO SELECT MI.
5. Once you have selected one of the two options displayed. .
  - A second scrolling message appears:
6. PUSH **\_M\_** TO SELECT C°, **\_S\_** TO SELECT F°.
7. Using the M button, toggle the secondary display to the clock function.
8. Press and hold the M button for three seconds, the clock will blink 12 and 24 alternately.
9. When your choice is displayed, press the M button to set it, the clock will blink the hour indication.
10. Press the S button repeatedly until the proper hour is displayed.
11. Press the M button to toggle to the minutes.
12. Press the S button repeatedly until the proper minutes are displayed.
13. Press the M button and the display will stop flashing and return to normal mode.

## ASSEMBLY INSPECTION

Inspect the following parts to make sure that the vehicle is properly assembled.

NOTE: [►Ensure that all protective materials are removed from vehicle.◄](#)

1. Front compartment cover and seat locks
2. Passenger grab handles
3. Front wheel lug nut torque (must be 105 N•m (77 lbf•ft))
4. Suspension arm ball joint cotter pins
5. Tie rod end nuts and cotter pins
6. Rear axle nut and cotter pin

7. Gearshift pedal operation
8. Parking brake pedal and cable operation
9. Brake lines
10. Foot pegs.

NOTE: Refer to the Predelivery Check List to confirm that all items are covered by your inspection.

## FINAL INSPECTION

### Vehicle Test Run

Ride the vehicle to ensure proper operation of all systems and components.

1. Instrument cluster operation and indicator-warning pilot lamps functioning on power up.
2. Display of safety message in cluster.
3. Starter interlock mechanism operation.
  - 3.1 Press start button to make sure engine can not be started if M button is not depressed to acknowledge safety message.
4. Cluster mode button and set button operation.
5. Check for error messages in cluster and correct if necessary.
6. Verify that both ignition keys allow the engine to start.
7. Brake operation.
  - The brake pedal is in front of the right footpeg.
  - Press it down to operate.
  - This pedal brakes all three wheels.
  - 7.1 Ensure brake pedal is firm when pressure is applied and that it returns freely.
8. Parking brake operation.
  - The parking brake pedal is behind the operator's left footpeg. This pedal brakes only the rear wheel.
  - 8.1 Press it down firmly until it locks to apply the parking brake.
  - 8.2 Firmly press the pedal down a second time to release the parking brake.
  - 8.3 Ensure parking brake is shut-off.
9. Reverse button operation (SE5 Model).
  - 9.1 Start engine.
  - 9.2 Shift in first gear, slightly apply on throttle then release.
  - 9.3 Shift in reverse, slightly apply on throttle then release.

- 9.4 Shift in neutral position, slightly apply on throttle then release.
10. Reverse interlock operation (SM5 Model).
- 10.1 With the engine running attempt to shift into reverse without pulling the reverse interlock lever back.
- 10.2 Release the clutch lever.
- 10.3 If the transmission is allowed to shift to reverse, the reverse interlock will need to be adjusted.
11. Throttle operation.
- The throttle is the right handgrip, and it controls engine speed. To increase engine speed, roll the throttle toward you. To decrease engine speed, roll the throttle away from you. The throttle is spring loaded and should return to idle when you release it.
- 11.1 With handlebars turned fully left and then fully right, ensure that the throttle returns completely to idle position.
12. Clutch lever operation (SM5 Model).
- The clutch lever is in front of the left handgrip. The clutch controls the transmission of power from the engine to the rear wheel. The lever is squeezed to disengage power and released to engage power.
13. Engine stop switch operation.
- The engine stop switch is near the right handgrip. It has two positions and must be set to the run position before you can start the engine. It allows you to stop the engine anytime without removing your hand from the handlebar.
14. Operation of the following lights:
- Headlights
  - Taillights
  - Brake light
  - Position lights
  - Turn signals
  - Hazard lights
  - Licence plate light.
15. Dimmer switch operation.
16. Headlight overrun button operation.
- There is a headlight override button on the front of the right handgrip.
17. Horn operation.
- The horn button is located near the left handgrip.
18. Leakage of the following fluids:
- Fuel

- Engine oil
- Engine coolant
- Brake fluid
- Clutch fluid

## Vehicle Cleaning

**NOTICE** Do not clean the windshield with alkaline or acid cleaner, gasoline or solvent to avoid windshield damage.

**NOTICE** Never use a high pressure washer to clean the vehicle. USE LOW PRESSURE ONLY (like a garden hose). The high pressure can cause electrical or mechanical damage.

**NOTICE** It is necessary to use flannel cloths on plastic parts to avoid damaging surfaces.

**NOTICE** Do not wash the seat with a vinyl or plastic cleaner because the seat may become slippery.

**NOTICE** Certain plastic or vinyl cleaners will damage the seat cover. Use only mild detergent, such as soap specially formulated for motorcycles or automobiles.

1. Wet the vehicle thoroughly with water.
2. Wash the vehicle with water mixed with a mild detergent, such as soap specially formulated for motorcycles or automobiles.
3. Dry the vehicle with a chamois or a soft towel.

**NOTE:** While washing the vehicle, check for grease or oil. If necessary, use a mild automotive degreaser and follow the manufacturer's instructions.

## Delivery to Customer

Complete the *PREDELIVERY CHECK LIST*.

The customer and dealer must read and sign the *PREDELIVERY CHECK LIST*.

# SPECIFICATIONS

MODEL			SPYDER RS		
<b>ENGINE</b>					
Engine type			ROTAX 991 60° V-Twin 4-stroke, Dual Over Head Camshaft (DOHC), liquid cooled		
Number of cylinders			2		
Number of valves			8 valves		
Bore			97 mm (3.82 in)		
Stroke			68 mm (2.68 in)		
Displacement			998 cm <sup>3</sup> (60.9 in <sup>3</sup> )		
Compression ratio			10.8:1		
Lubrication	Type		Dry sump with separate oil tank and oil cooler		
	Oil filter	Engine		BRP Rotax paper type, replaceable	
		Transmission (SE5)		BRP Rotax paper type, replaceable	
	Engine oil Capacity	Oil change with new engine filter	SM5	3.9 L (4.1 qt (U.S. liq.))	
		Oil change with new engine filter	SE5	4.2 L (4.4 qt (U.S. liq.))	
		Oil change with new engine and HCM filters		4.3 L (4.5 qt (U.S. liq.))	
Recommended Engine Oil			Use XPS SYNTHETIC BLEND OIL (SUMMER GRADE) (P/N 293 600 121) or a 5W 40 semi-synthetic (minimum) or synthetic motorcycle oil meeting the requirements for API service SL, SJ, SH or SG classification.		
Clutch	SM5 model	Type	Wet, multi-plate, manual operation through a hydraulic piston, vacuum assist		
		Fluid	DOT 4		
	SE5 model	Type	Centrifugal clutch + wet multi-plate clutch automatically controlled by TCM		
		Engage-ment	2000 +/- 200 RPM (centrifugal)		
		Stall	3200 +/- 200 RPM (centrifugal)		
		Exhaust system			2 into 1 with catalytic converter
Air filter			Paper element		
<b>GEARBOX</b>					
Type	SM5		Sequential Manual 5-speed (SM5) with reverse		
	SE5		Sequential Electronic 5-speed (SE5) with reverse		
<b>COOLING SYSTEM</b>					
Type			Liquid cooled, single radiator with cooling fan		
Coolant	Type		Ethyl glycol/water mix (50% coolant, 50% distilled water). Use BRP PREMIXED COOLANT (P/N 219 700 362) or coolant specifically designed for aluminum engines		
	Capacity		3.2 L (3.4 qt (U.S. liq.))		

MODEL		SPYDER RS
<b>ELECTRICAL SYSTEM</b>		
Magneto generator output		500 W
Ignition system type		Electronic ignition with dual output coil
Ignition timing		Not adjustable
Spark plug	Quantity	2
	Make and type	NGK DCPR9E (apply heat-sink paste P12 (P/N 420 897 186) on spark plug thread)
	Gap	0.7 mm - 0.8 mm (.028 in - .031 in)
Engine RPM limiter setting	Forward	10 000 RPM
Battery	Type	Maintenance free
	Voltage	12 volts
	Nominal rating	21 A•h
	Recommended charging rate	2 A
Headlight		2 x 55 W CE Models: 4 x 60W
Tail light/brake light		2 x 5/21 W
Turn signal lights	Front	21 W
	Rear	21 W
Position lights		2 x 5 W
License plate light		10 W
Fuses under service cover	Main relays control ECM control Pillion rider switch (PRS) Vehicle control module (VCM) Steering angle sensor (SAS) Yaw rate sensor (YRS)	10 A
	Clutch valve Horn Service connector	10 A
	Accessories	2 x 3 A
	Dynamic Power Steering control (DPS) Transmission control Module (TCM) (SE5 model)	5 A

SPECIFICATIONS

MODEL		SPYDER RS		
<b>ELECTRICAL SYSTEM (cont'd)</b>				
Fuses under service cover	Camshaft position sensor (CAPS) Engine control module (ECM) Fuel pump O <sup>2</sup> heater Purge valve Starter solenoid		10 A	
	D.E.S.S. License plate light Position light Tail lights Service connector		10 A	
	Ignition coil Fuel injectors		15 A	
	Clock Hazard warning lights Turn signal lights		10 A	
	Fan		15 A	
	Multifunction gauge cluster		5 A	
	Fog lights (optional)		10 A	
	Fuses under seat	Blipper (SE5 model) TCM valves (SE5 model)		20 A
		Rectifier		60 A
Main fuse		40 A		
Dynamic Power Steering (DPS) motor		40 A		
VSS pump		40 A		
Headlights		30 A		
VSS valves		25 A		
<b>FUEL SYSTEM</b>				
Fuel delivery		Type Multi-point Electronic Fuel Injection (EFI) with dual 57 mm throttle body		
Fuel pump		Type Electrical module in fuel tank		
Idle speed		1400 ± 100 RPM (not adjustable)		
Fuel	Type Regular unleaded gasoline			
	Octane no.	Inside North America 87 (R+M)/2 or higher		
		Outside North America 92 RON or higher		
Fuel tank capacity		25 L (6.6 U.S. gal.)		
<b>DRIVE SYSTEM</b>				
Final drive type		Carbon reinforced drive belt		
Final drive ratio		28/79		
<b>STEERING</b>				
Type		Dynamic Power Steering (DPS)		

MODEL		SPYDER RS
<b>FRONT SUSPENSION</b>		
Suspension type		Double A-arm with anti-roll bar
Suspension travel		144 mm (5.7 in)
Shock absorber	Qty	2
	Type	Oil damper
Spring preload adjustment		5 position cam adjustment
<b>REAR SUSPENSION</b>		
Suspension type		Swing arm with monoshock
Suspension travel		145 mm (5.7 in)
Shock absorber	Qty	1
	Type	Oil damper
Spring preload adjustment		7 position cam adjustment
<b>BRAKES</b>		
Type		Foot-actuated, fully integrated hydraulic 3-wheel braking system with ABS and EBD
Front brake		Dual discs (250 mm x 6 mm) (10.2 in x 0.25 in) with 4 piston calipers
Rear brake		Single disc (250 mm x 6 mm) (10.2 in x 0.25 in) with 1 piston caliper
Brake fluid	Capacity	545 ml - 570 ml (18.4 U.S. oz - 19.3 U.S. oz)
	Type	DOT 4
Parking brake		Mechanical, left foot pedal actuated to the rear caliper
Minimum brake pad thickness		1 mm (.04 in)
Minimum brake disc thickness		5.33 mm (.21 in)
Maximum brake disc warpage		0.12 mm (.005 in)
<b>TIRES</b>		
Type (use only tires recommended by BRP)	Front	Kenda KR21 MC 165/65R14 47H (special motorcycle type)
	Rear	Kenda KR21 MC 225/50R15 68H or 76H (special motorcycle type)
Pressure	Front	Nominal.: 103 kPa (15 PSI) Min.: 89 kPa (13 PSI) Max.: 117 kPa (17 PSI)  NOTE: The pressure difference between the left and right side tire should not exceed 3.4 kPa (.5 PSI).
	Rear	Nominal.: 193 kPa (28 PSI) Min.: 179 kPa (26 PSI) Max.: 207 kPa (30 PSI)
Minimum tire tread depth	Front	2.5 mm (3/32 in)
	Rear	4.0 mm (5/32 in)
<b>WHEELS</b>		
Size (diameter X width)	Front	355 mm x 127 mm (14 in x 5 in)
	Rear	381 mm x 178 mm (15 in x 7 in)
Front wheel nuts torque		105 N•m (77 lbf•ft)
Rear drive axle nut torque		130 N•m (96 lbf•ft)

## SPECIFICATIONS

MODEL		SPYDER RS
<b>DIMENSIONS</b>		
Overall length		2 667 mm (105 in)
Overall width		1 506 mm (59.3 in)
Overall height		1 145 mm (45.1 in)
Seat (top) height		737 mm (29 in)
Wheel base		1 727 mm (68 in)
Front wheel track		1 308 mm (51.5 in)
Ground clearance, front and under engine		115 mm (4.5 in)
<b>WEIGHT AND LOADING CAPACITY</b>		
Dry weight		317 kg (699 lb)
Front storage compartment	Capacity	44 L (11.6 U.S. gal.)
	Maximum load	16 kg (35 lb)
Total vehicle load allowed (including operator, all other loads and added accessories)		200 kg (440 lb)
Gross vehicle weight rating (GVWR)		540 kg (1,188 lb)

Because of our ongoing commitment to product quality and innovation, BRP reserves the right, at any time, to make changes in design and specifications and/or to make additions to, or improvements in its products without imposing any obligation upon itself to install them on its previously manufactured products.