

CLUTCH (SM5)

SERVICE TOOLS

Description	Part Number	Page
BLIND HOLE BEARING PULLER SET.....	529 036 117	29
CLUTCH ASSEMBLY HOLDER	529 035 618	31
ECM ADAPTER TOOL.....	420 277 010	16
FLUKE 115 MULTIMETER	529 035 868	15
VACUUM/PRESSURE PUMP	529 021 800	8-9, 12, 17

SERVICE PRODUCTS

Description	Part Number	Page
BRAKE FLUID GTLMA (DOT 4).....	293 600 062	6
LOCTITE 243 (BLUE).....	293 800 060	24
LOCTITE 648 (GREEN)	413 711 400	32, 35
PETAMO GREASE GHY 133N	420 899 271	30-31
PULLEY FLANGE CLEANER	413 711 809	28

Subsection XX (CLUTCH (SM5))

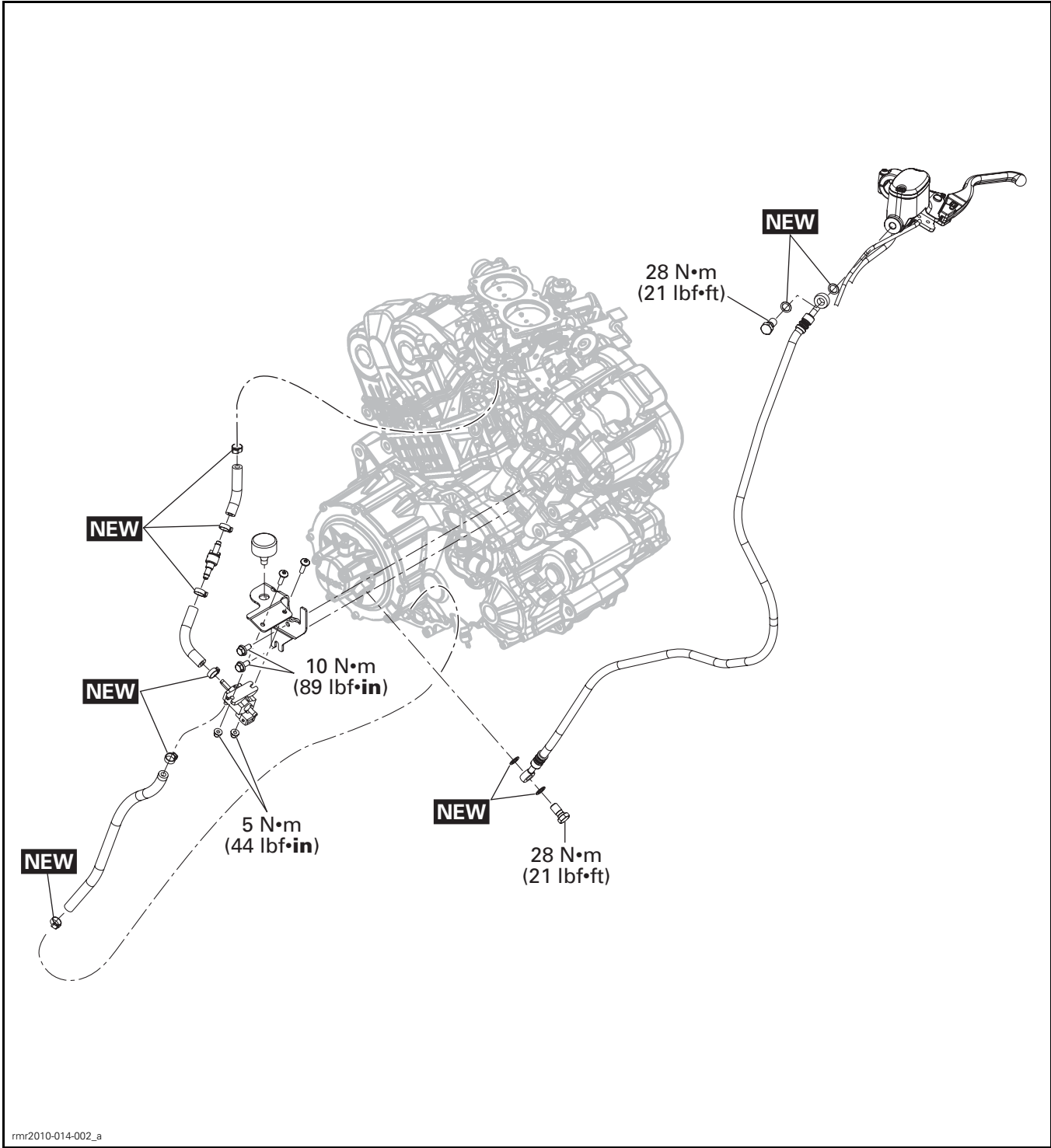

rmr2010-014-002_a

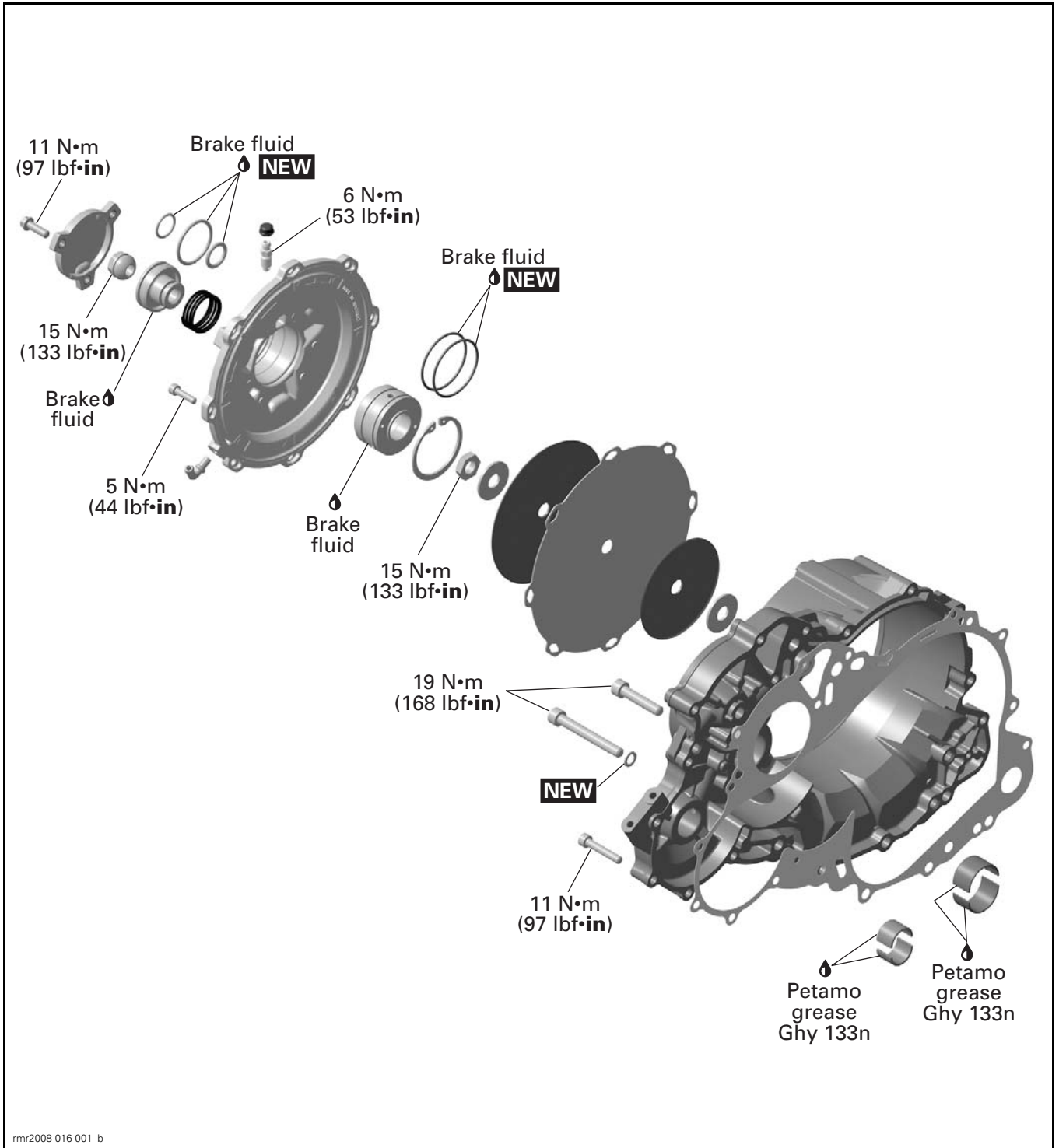

rnr2008-016-001_b

Subsection XX (CLUTCH (SM5))

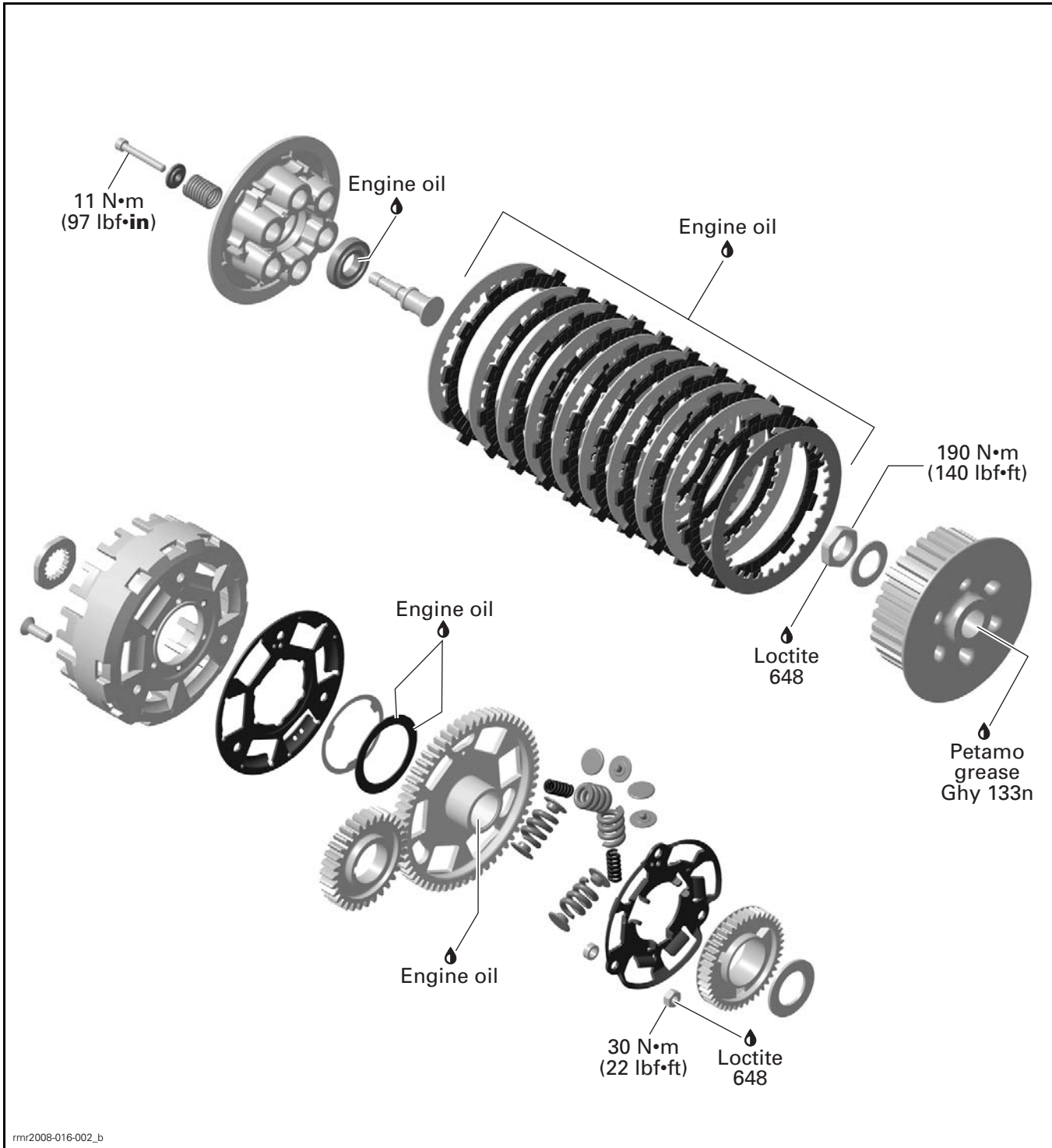

GENERAL

NOTE: For a better understanding, many of the following illustrations are produced with the engine out of vehicle. To carry out the instructions, it is not necessary to remove the engine from vehicle.

Always disconnect the battery negative cable before working the engine.

⚠ WARNING
Always disconnect BLACK (-) cable first and reconnect last.

During assembly/installation, use torque values and service products as specified in the exploded views.

Clean threads before applying a threadlocker. Refer to *SELF-LOCKING FASTENERS* and *LOCTITE APPLICATION* at the beginning of this manual for complete procedure.

⚠ WARNING
Torque wrench tightening specifications must be strictly adhered to. Locking devices (e.g.: locking tabs, elastic stop nuts, cotter pins, etc.) must be replaced with new ones.

NOTICE Hoses, cables or locking ties removed during a procedure must be reinstalled as per factory standards.

NOTICE Avoid spilling brake fluid on plastic, rubber or painted parts. Protect these parts with a rag when servicing the hydraulic clutch system.

NOTICE Sealing washers must be discarded and replaced with new ones every time a Banjo fitting is unscrewed.

Periodically check the clutch hoses for damages or leaks. Repair any damages or leaks.

SYSTEM DESCRIPTION

The engine on the SM5 model features a hydraulically operated pneumatically assisted type clutch system.

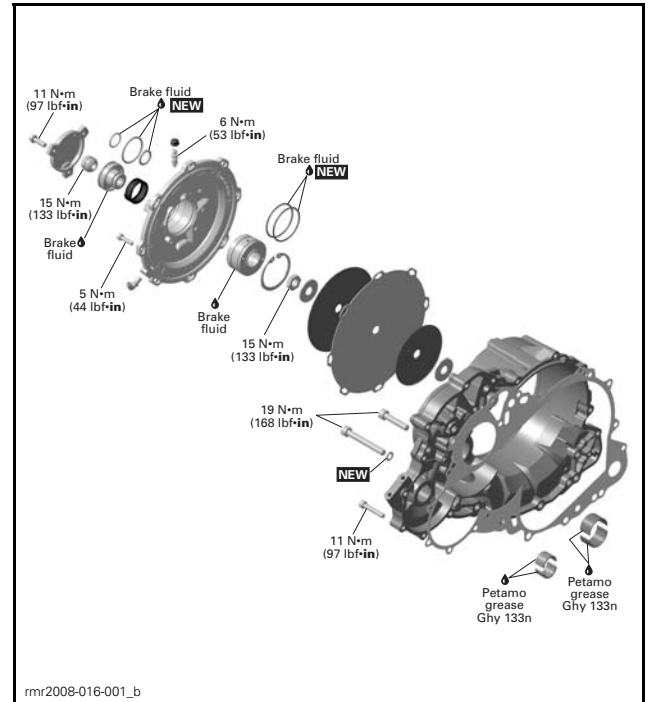

A diaphragm assists the hydraulic system in displacing the pressure plate to disengage the clutch. The diaphragm is activated by vacuum applied through an electronically controlled solenoid valve (controlled by the ECM).

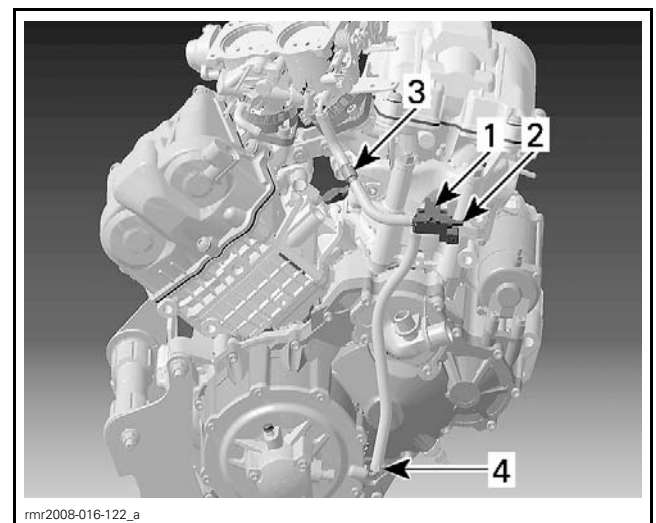

- TYPICAL**
1. Solenoid
 2. Vent to atmosphere
 3. Check valve
 4. Vacuum to clutch release servo

When the clutch lever is depressed and the engine is running, the ECM modulates the clutch solenoid valve to provide a variable assist to the clutch.

Subsection XX (CLUTCH (SM5))

The pneumatic assist will vary according to throttle position and to the engine RPM up to approximately 4000 RPM. Beyond that, there will not be any pneumatic assist.

- The lower the engine RPM, the greater the assist will be.
- The lesser the throttle opening, the greater the assist will be.

A check valve is used to allow only vacuum pulses to go towards diaphragm. Therefore, its orientation is important for proper operation.

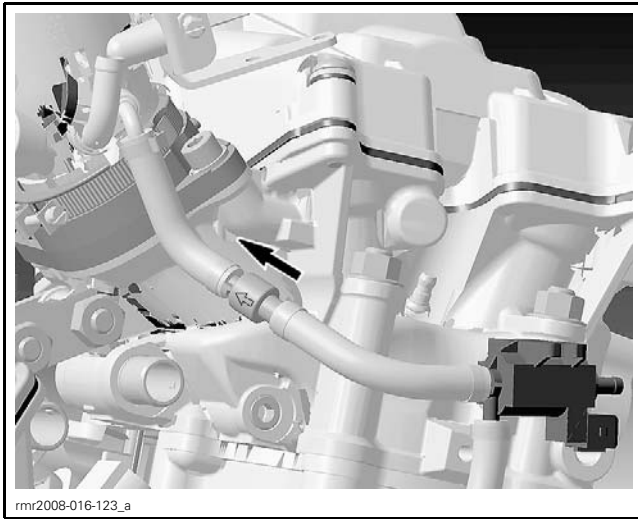

When the clutch solenoid is not activated, the diaphragm vacuum hose is opened to atmospheric pressure which allows the diaphragm to return to its free position.

NOTE: A damaged diaphragm will cause engine oil to be drawn into the air intake from the clutch area. The burning engine oil will produce blue smoke out of the exhaust system.

MAINTENANCE

CLUTCH FLUID

Recommended Clutch Fluid

Use only DOT 4 BRAKE FLUID GTLMA (DOT 4) (P/N 293 600 062) or equivalent.

NOTICE To avoid serious damage to the hydraulic clutch system, use only brake fluid of the recommended type from a sealed container. Do not use fluid from an old or already opened container, nor mix different fluids for topping up the system.

Clutch Fluid Level Verification

Ensure vehicle is on a level surface.

Set the handlebar in the straight ahead position.

Wipe clean the reservoir cap area.

Unscrew retaining screws of reservoir cap using a Phillips screwdriver.



Carefully remove reservoir cap. Pay attention not to drop the seal.

Look inside the the reservoir to see the fluid level. The fluid should be within the maximum level and the minimum level.

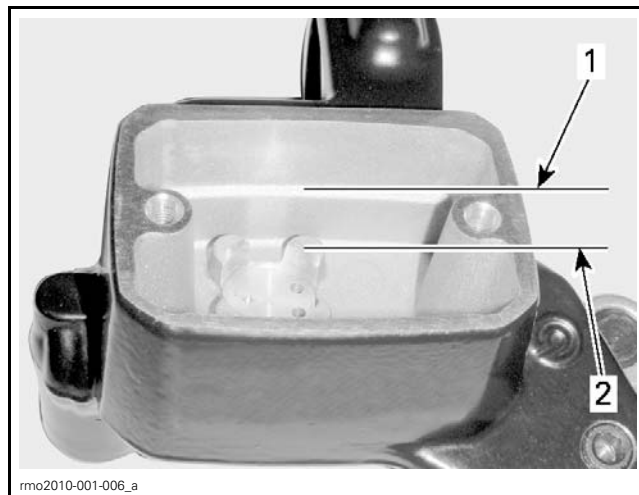

FLUID REMOVED FOR CLARITY PURPOSE

1. Maximum level (line)
2. Minimum level (top of protuberance)

If the fluid level is lower than specified, add fluid to the reservoir up to the maximum level line. Do not overfill.

⚠ WARNING

Avoid getting brake fluid on skin or in eyes, it may cause severe burns. In case of contact with the skin, wash thoroughly. In case of contact with the eyes, immediately rinse with plenty of water for at least 10 minutes and then consult a doctor immediately.

NOTE: A low level may indicate leaks or worn clutch discs.

Reinstall the reservoir cover.

NOTE: Ensure seal is located inside reservoir cap and the seal is completely collapsed.

Clutch Fluid Replacement

Clutch Fluid Draining

Remove the following RH body panels, refer to *BODY* subsection:

- Top side panel
- Rear side panel

Remove clutch reservoir cover screws. Do not remove cover at this time.



rmo2010-001-005

NOTICE Leave cover on reservoir to avoid spillage during the following procedure.

Connect a clear hose to the clutch bleeder on the clutch cover.

Insert the other end of the hose in an appropriate container (such as an empty break fluid bottle).



rmr2008-016-116

TYPICAL

Loosen the clutch bleeder.

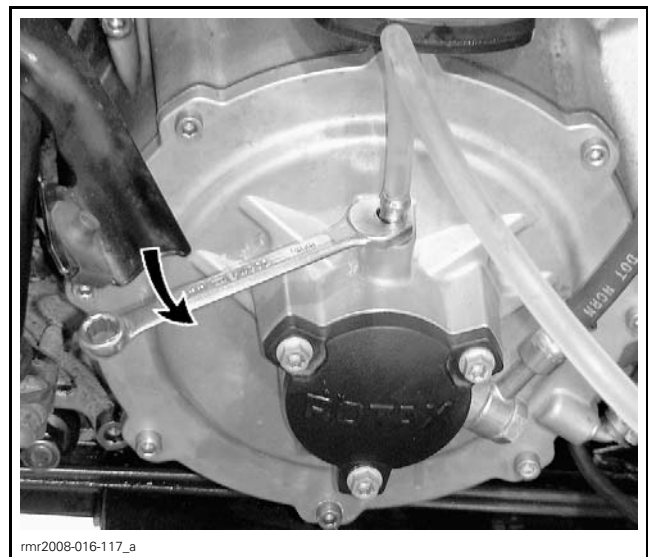

rmr2008-016-117_a

TYPICAL

Depress and release the clutch lever several times until no more fluid flows out of bleeder.

Subsection XX (CLUTCH (SM5))

Clutch Bleeding Procedures

Clutch Fluid Bleeding using a Pump (System Completely Empty)

NOTE: If the system is completely empty, it is easier to bleed the system by pushing the fluid from the bleeder to the reservoir. Use the following procedure.

Install the VACUUM/PRESSURE PUMP (P/N 529 021 800) and the remote reservoir onto the clutch bleeder with a clear hose. See following illustration.



rmr2008-016-113_a

TYPICAL

Tighten bleeder.



529021800

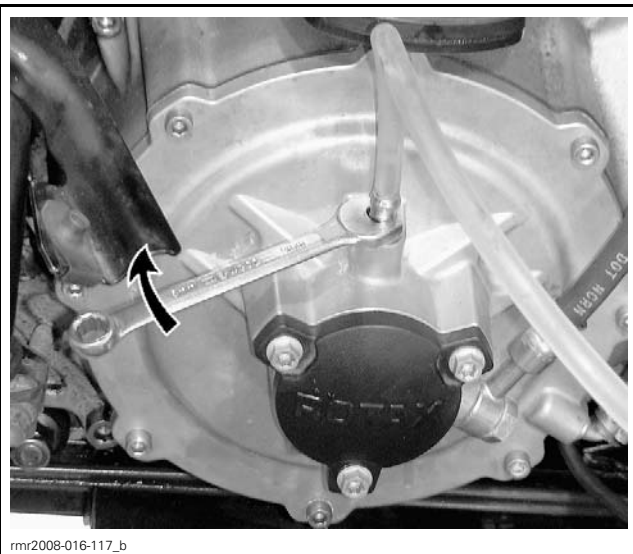

rmr2008-016-117_b

TYPICAL

Clutch Fluid Filling

Remove reservoir cover.

Turn handlebar fully on right side.

NOTE: Turning the handlebar will help the bleeding process.

Fill reservoir with the recommended fluid.

Bleed system using the *CLUTCH FLUID BLEEDING USING A PUMP (SYSTEM COMPLETELY EMPTY)* procedure.

NOTE: If a pump is not available, use the *CLUTCH FLUID BLEEDING WITHOUT A PUMP* procedure.



rmr2008-021-016-500

TYPICAL - PUMP AND REMOTE RESERVOIR INSTALLATION

Add recommended fluid in the pump remote reservoir.

Set pump to the PRESSURE position.

Loosen clutch bleeder.

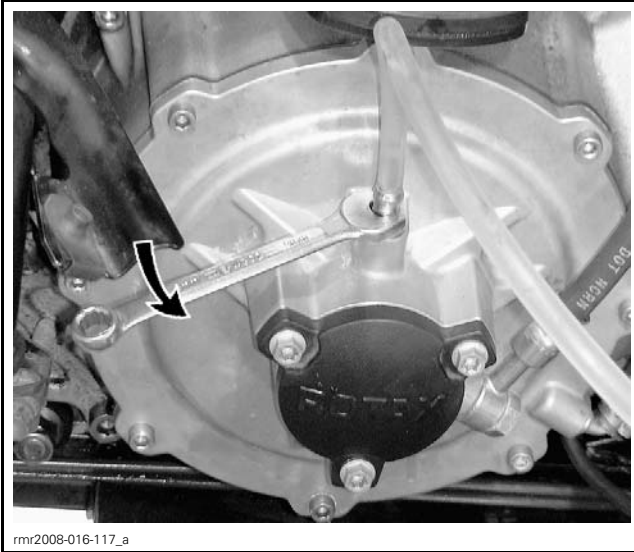

rmr2008-016-117_a

TYPICAL - LOOSEN CLUTCH BLEEDER

Activate the pump lever several times until fluid reaches the clutch reservoir. Then, tighten bleeder.

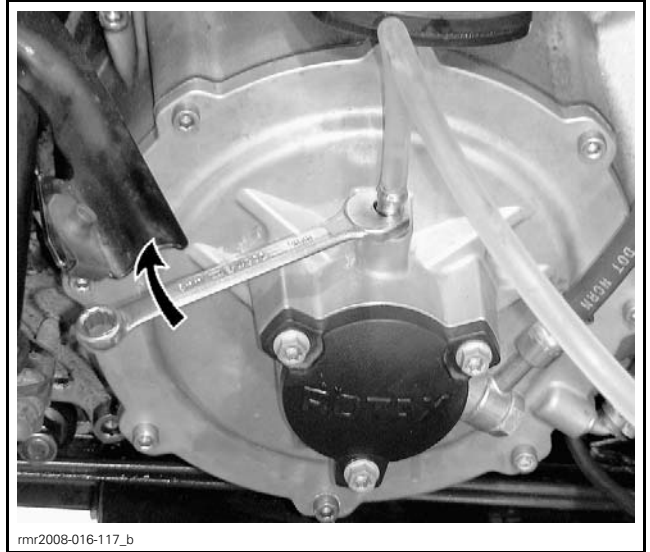

rmr2008-016-117_b

TYPICAL - TIGHTEN CLUTCH BLEEDER

Depress clutch lever several times. If it feels spongy, bleed system again using the *CLUTCH FLUID BLEEDING USING A PUMP (SYSTEM NOT COMPLETELY EMPTY)* procedure.

Top up fluid reservoir.

Install cover on reservoir.

Clutch Fluid Bleeding using a Pump (System Not Completely Empty)

Install the VACUUM/PRESSURE PUMP (P/N 529 021 800) and the remote reservoir onto the clutch bleeder with a clear hose. See following illustration.



rmr2008-021-016-501

ACTIVATE PUMP UNTIL FLUID REACHES CLUTCH RESERVOIR



529021800

Subsection XX (CLUTCH (SM5))



rnr2008-021-016-500

TYPICAL - PUMP AND REMOTE RESERVOIR INSTALLATION

Set pump to the VACUUM position.
Loosen clutch bleeder.

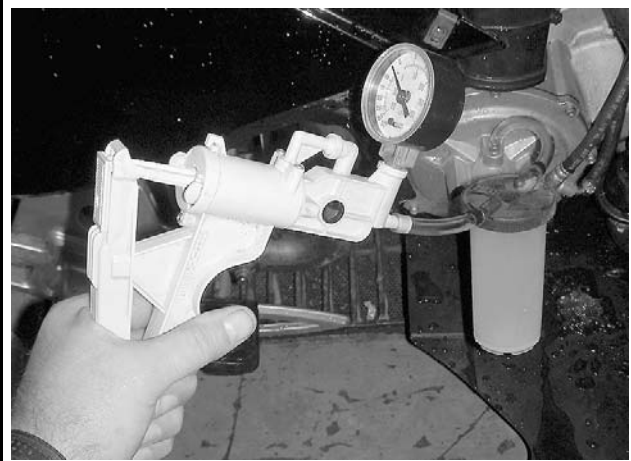

rnr2008-021-016-501

ACTIVATE PUMP UNTIL NO MORE AIR COMES OUT

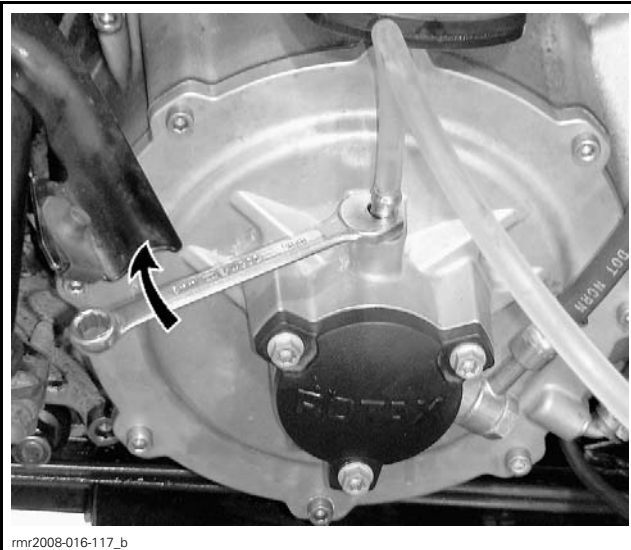

rnr2008-016-117_b

TYPICAL - TIGHTEN CLUTCH BLEEDER

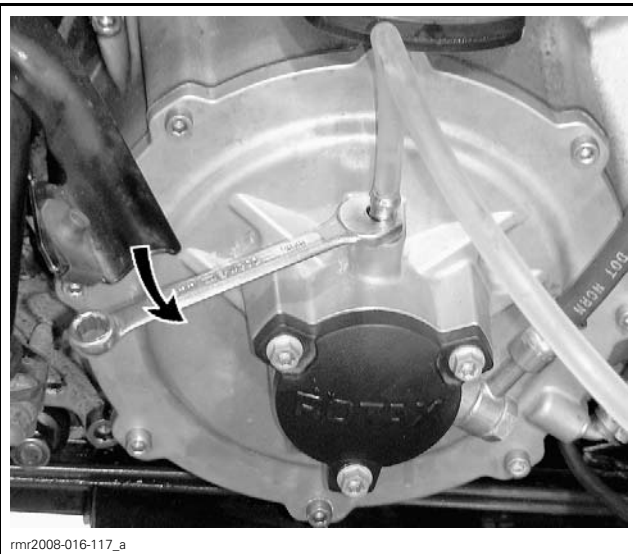

rnr2008-016-117_a

TYPICAL - LOOSEN CLUTCH BLEEDER

Depress and release the pump lever several times until no more air bubbles flow out of bleeder. Then, tighten bleeder.

NOTE: Check the clutch fluid level in reservoir often to prevent air from being drawn into the system.

Depress clutch lever several times. If it feels spongy, repeat procedure until system is entirely bled of trapped air.

Top up fluid reservoir.

Install cover on reservoir.

Clutch Fluid Bleeding without a Pump

If a pump is not available, use the following procedure.

Connect a clear hose to the clutch bleeder.

Insert the other end of the hose into a **clean** container containing enough new brake fluid for the end of the hose to be submerged.



TYPICAL

Loosen the clutch bleeder.



TYPICAL

Tighten the clutch bleeder.

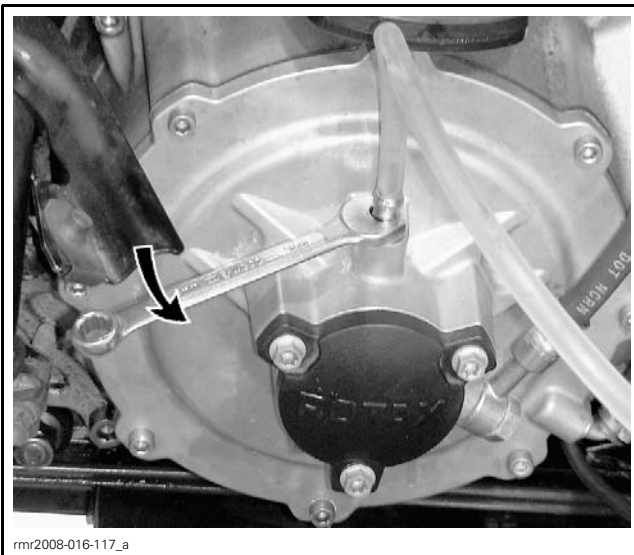

TYPICAL

Depress the clutch lever until it reaches the end of its stroke.

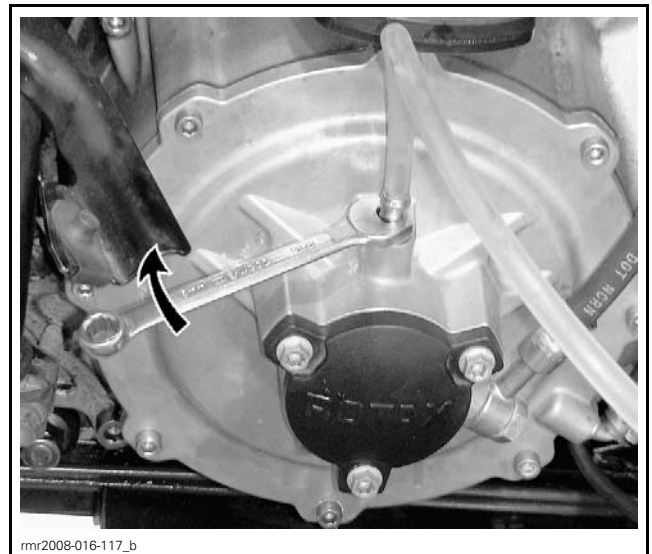

TYPICAL

Release the clutch lever.

Subsection XX (CLUTCH (SM5))



TYPICAL

IMPORTANT: Do not release clutch lever until bleeder has been tightened.

Repeat this sequence of depressing lever and loosening/tightening bleeder screw until no more air bubbles appear in hose.

NOTE: Check fluid level often to prevent air from being pumped into the system.

Depress clutch lever several times. If it feels spongy, repeat the procedure until system is entirely bled of trapped air.

Top up reservoir.

Install cover on reservoir.

TROUBLESHOOTING

CLUTCH OPERATION TEST

Pneumatic Assist Quick Test

With the engine **not** running, depress the clutch lever a few times.

Note clutch lever resistance.



TYPICAL

Start engine and let run **at idle**.

Depress clutch lever a few times.

Compare lever resistance with and without engine running.

Lever must be easier to depress when the engine is running. Otherwise, carry out a **VACUUM LEAK TEST**.

Vacuum Leak Test

Disconnect vacuum hose from clutch cover fitting.

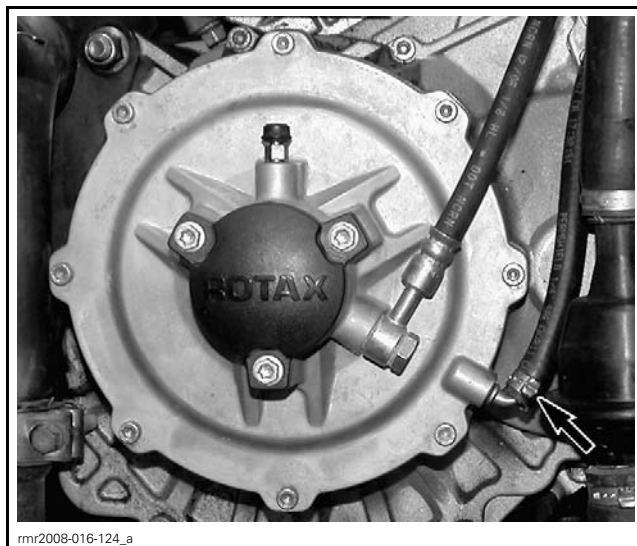

Install the VACUUM/PRESSURE PUMP (P/N 529 021 800) onto the clutch cover vacuum hose fitting.



529021800



rmr2008-016-125

TYPICAL

Set the pump to vacuum and activate its lever several times until vacuum specified in the following table is obtained.

VACUUM LEAK TEST	
VACUUM	TIME WITHOUT LEAK
25 in Hg	30 seconds

If vacuum leaks, check the following:

- Clutch cover screws for tightness
- Tightness of diaphragm nut
- Diaphragm.

If the vacuum leak test was good, check the vacuum-assist components.

NOTE: If there is no clutch assist or only partial assist, the check valve should be suspected.

Remove the vacuum/pressure test pump and hose.

Install the system vacuum hose on the clutch cover and secure it as specified in the exploded view.

Hydraulic Operation Test

Remove hydraulic clutch piston cover.

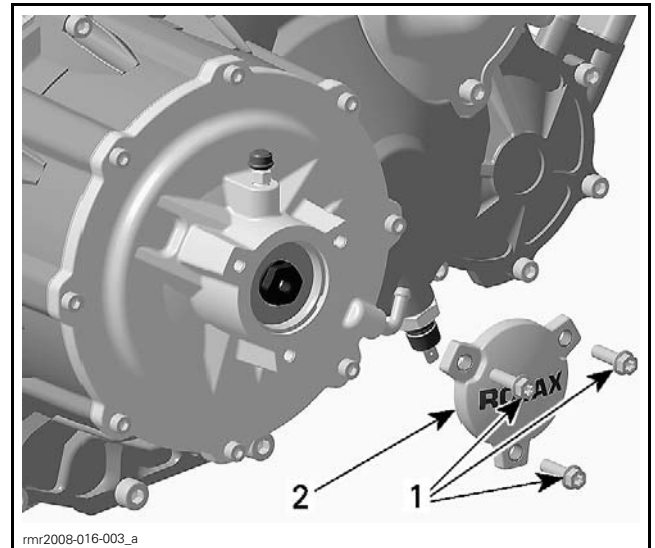

rmr2008-016-003_a

1. Screws
2. Clutch piston over

Observe the hydraulic piston position.

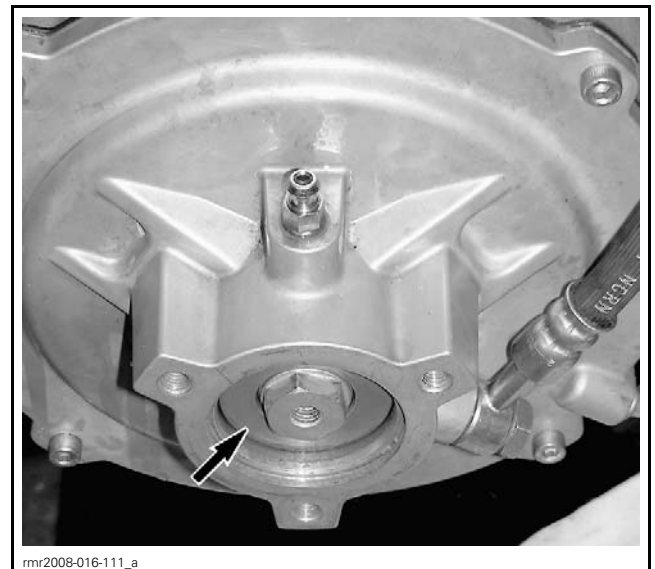

rmr2008-016-111_a

CLUTCH HYDRAULIC PISTON

Fully depress clutch lever and hold.

Subsection XX (CLUTCH (SM5))



Again, observe the hydraulic piston position.

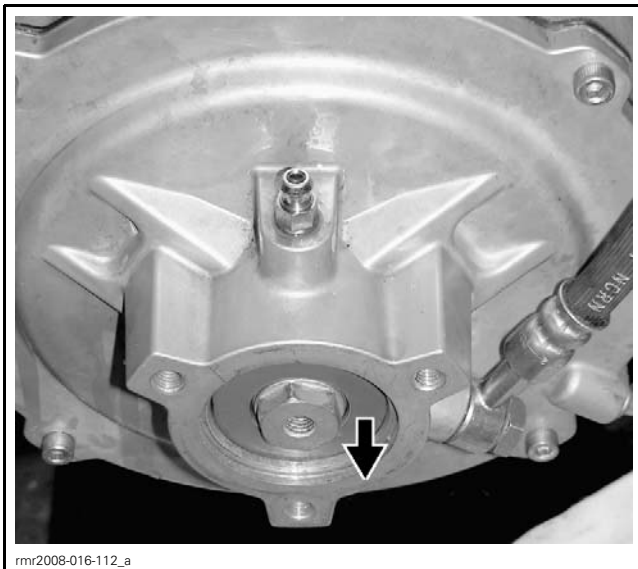

MOVEMENT OF CLUTCH HYDRAULIC PISTON

It should move outwards approximately 2 mm (.079 in).

NOTE: Ensure clutch lever adjustment is set to allow maximum piston stroke. Also, piston must maintain its position as long as clutch lever is held depressed.

If clutch piston does not maintain its position while clutch lever is depressed, check the hydraulic components.

PROCEDURES

CLUTCH LEVER

Clutch Lever Inspection

Check clutch lever for cracks or other damages.

Replace as required.

Clutch Lever Replacement

Remove screw and nut retaining the clutch lever.

Remove clutch lever.

Installation is the reverse of the removal.

MASTER-CYLINDER

Master-Cylinder Removal

Drain fluid from clutch system. Refer to *CLUTCH FLUID REPLACEMENT* procedure in this subsection.

Loosen torque on screw retaining clutch fluid hose to reservoir.

NOTE: Do not remove screw at this time to avoid spillage.

Remove screws retaining master-cylinder to handlebar.

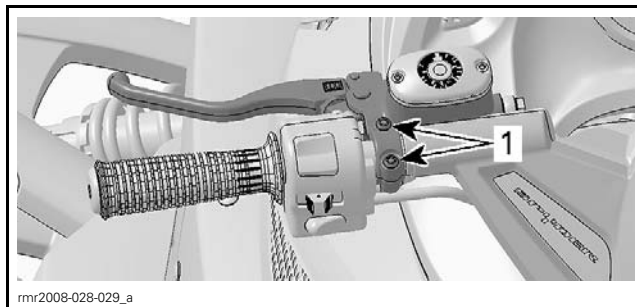

TYPICAL
1. Screws

Place master-cylinder reservoir over a drain pan.

Remove the retaining screw and clutch fluid hose from the master cylinder.

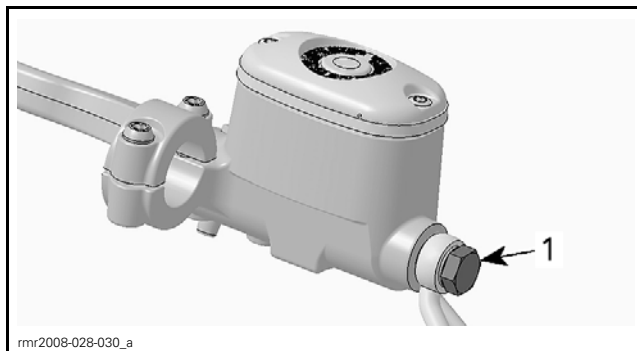

TYPICAL
1. Remove screw

Empty reservoir into drain pan.

Tie off clutch hose to handlebar to avoid spillage.

NOTICE Be sure to protect all parts from the brake fluid as it will strip the finish off parts. Clean off any spillage immediately.

Discard sealing washers.

Remove clutch switch. Refer to *STARTING SYSTEM* subsection.

Remove master-cylinder.

Master-Cylinder Installation

Installation is the reverse of the removal procedure, however pay attention to the following.

If clutch fluid hose was disconnected:

- Replace both sealing washers on clutch hose fitting.
- Bleed clutch system. Refer to *CLUTCH BLEEDING PROCEDURES* in this subsection.

CLUTCH SOLENOID VALVE

Clutch Solenoid Valve Test with B.U.D.S.

Connect to the latest B.U.D.S. software, refer to *COMMUNICATION TOOLS AND B.U.D.S. SOFTWARE*.

Select the **Read Data** button.

Select the **Faults** page tab.

Check for fault codes.

To test the solenoid valve operation, select the **Activation** page tab and confirm you are on the **ECM** page.

Activate the clutch solenoid valve by selecting the solenoid symbol.

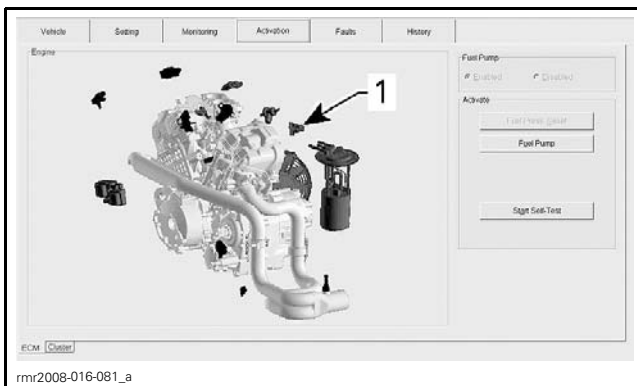

1. Activate here

This will validate the clutch solenoid mechanical and electrical operation.

If the solenoid valve works, check clutch components.

If the solenoid valve does not work, proceed with a voltage test.

Input Voltage Test (Clutch Solenoid Valve)

Remove the RH upper side panel, refer to the *BODY* subsection.

Disconnect the solenoid valve connector and turn ignition switch to ON.

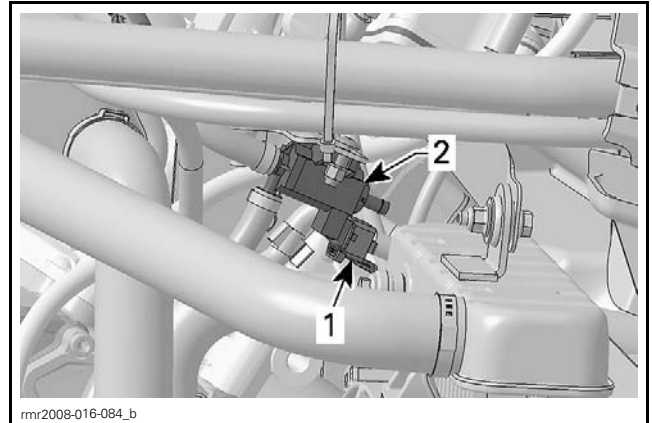

1. Clutch solenoid valve connector
2. Clutch solenoid valve

Set the FLUKE 115 MULTIMETER (P/N 529 035 868) to Vdc setting.

INPUT VOLTAGE TEST (CLUTCH SOLENOID VALVE)		
TEST PROBES		VOLTAGE
Clutch solenoid valve connector Pin 2	Battery ground	Battery voltage

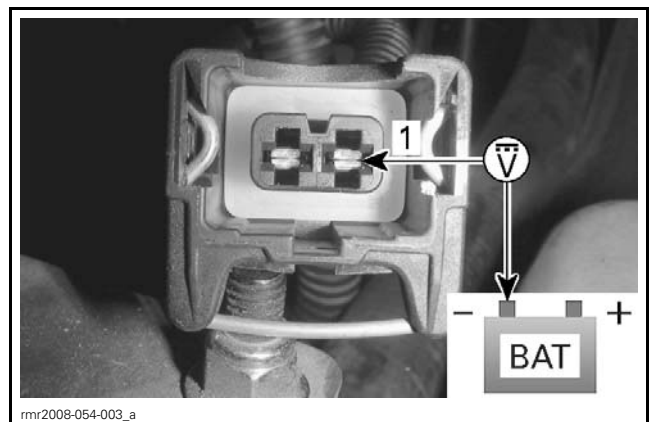

INPUT VOLTAGE TEST (CLUTCH SOLENOID VALVE)

If you do not measure battery voltage, check fuse F2. If F2 is good, test the circuit continuity from the fuse to the clutch valve solenoid.

NOTE: If F2 is blown, the horn will not function.

Subsection XX (CLUTCH (SM5))

If battery voltage is measured, test clutch solenoid valve resistance.

Clutch Solenoid Valve Resistance Test

Disconnect clutch solenoid connector.

Set the multimeter to Ω setting.

Measure the clutch solenoid resistance as per following table.

CLUTCH SOLENOID VALVE RESISTANCE TEST	
TEST PROBES	RESISTANCE @ 20°C (68°F)
Solenoid pins 1 and 2	23 ± 1.2 Ω

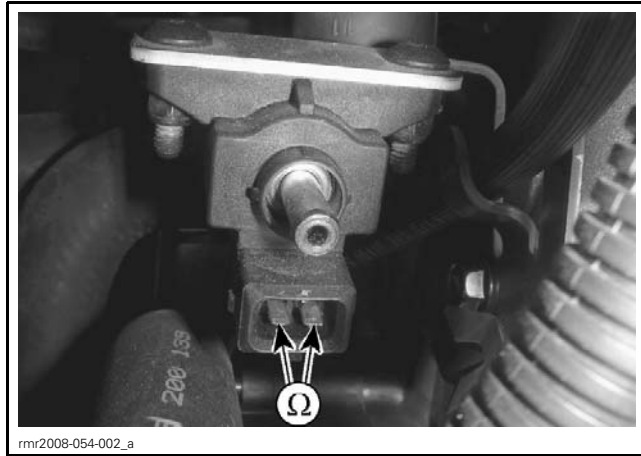

If resistance is out of specification, replace the solenoid.

If solenoid resistance is good, carry out a circuit continuity test.

Circuit Continuity Test (Clutch Solenoid Valve)

Ensure ignition switch is OFF.

Remove fuse F2.

Remove ECM connector "B" and install it on the ECM ADAPTER TOOL (P/N 420 277 010).

Set multimeter to Ω setting and measure the circuit continuity as per following table.

CIRCUIT CONTINUITY TEST (CLUTCH SOLENOID VALVE)		
TEST PROBES		RESISTANCE @ 20°C (68°F)
Clutch solenoid connector pin 2	Fuse F2 (contact E7)	Close to 0 Ω
Clutch solenoid connector pin 1	ECM adapter B-4	

If resistance is out of specification, repair or replace wiring/connectors.

If solenoid resistance, input voltage and circuit continuity all tested good, check for the following:

- An obstructed vacuum hose
- A stuck solenoid valve plunger
- A malfunctioning clutch solenoid check valve.

Repair or replace as applicable.

Clutch Solenoid Valve Removal

Remove the RH top side panel. Refer to the *BODY* subsection.

Disconnect clutch valve solenoid connector.

Remove screws securing clutch solenoid valve to support bracket.

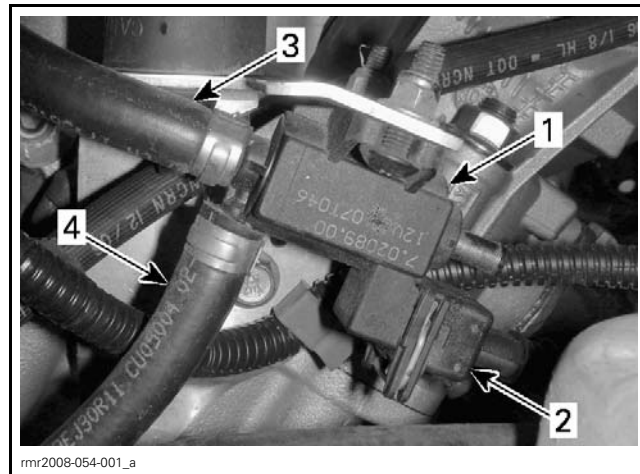

1. Solenoid valve
2. Solenoid connector
3. Vacuum hose from throttle body
4. Vacuum hose to clutch housing

Cut Oetiker clamps and remove hoses from clutch valve solenoid.

NOTE: Mark hoses location for reinstallation.

Clutch Solenoid Valve Installation

For installation, reverse the removal procedure.

CHECK VALVE (CLUTCH SOLENOID VALVE)

Check Valve Removal

Remove the air filter housing. Refer to *AIR INTAKE SYSTEM*.

Cut Oetiker clamps retaining the check valve.

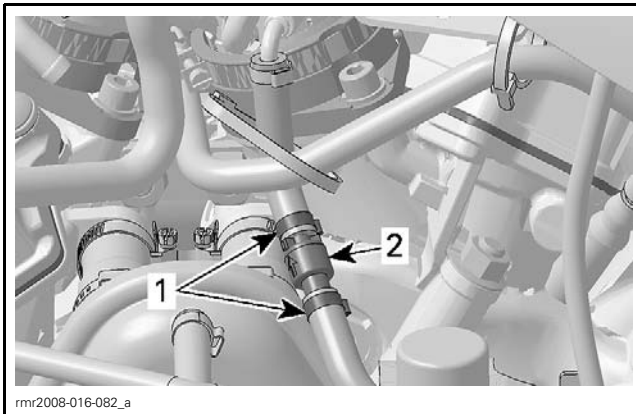

1. Oetiker clamps
2. Check valve

Remove the check valve.

Check Valve Inspection

Using the VACUUM/PRESSURE PUMP (P/N 529 021 800), test the check valve operation.



Check Valve Installation

Install the check valve with the flow arrow pointing towards the throttle body.

Install **NEW** Oetiker clamps.

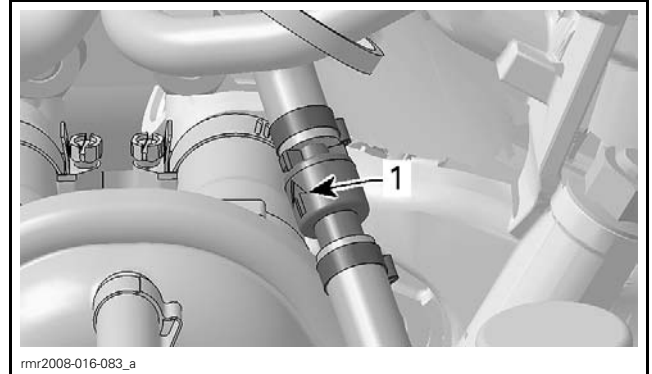

1. Flow arrow towards throttle body

Install all other removed parts.

HYDRAULIC PISTON

Hydraulic Piston Removal

Remove hydraulic piston cover screws.

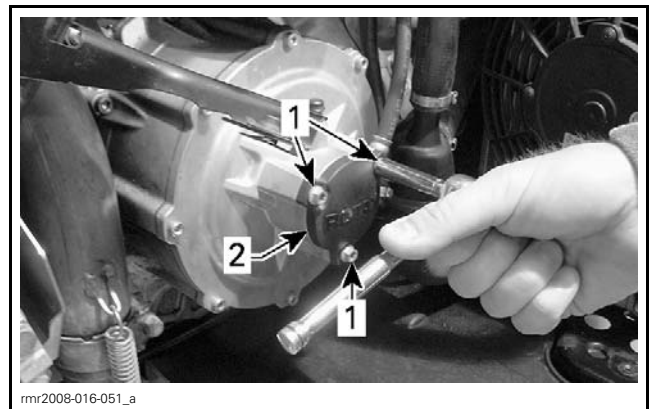

1. Screws
2. Hydraulic piston cover

Using a 17 mm deep offset wrench, unscrew the hydraulic piston nut **while holding the clutch release shaft** with a 5 mm Allen wrench. **The diaphragm must not twist.**

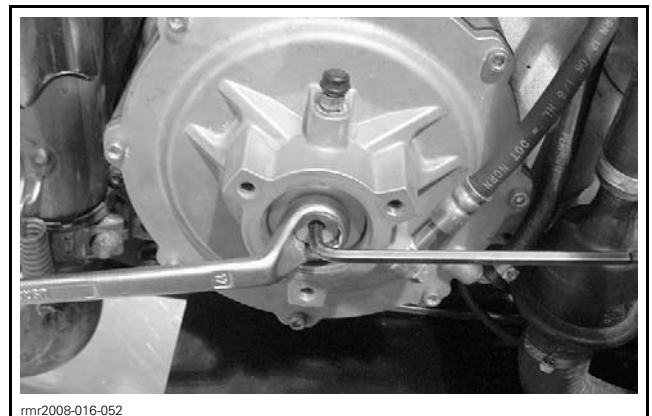

Subsection XX (CLUTCH (SM5))

NOTICE Hold the clutch release shaft with the Allen wrench to avoid twisting and damaging the diaphragm.

Squeeze clutch lever a few times to push hydraulic piston out of the clutch cover.

Remove compression spring.

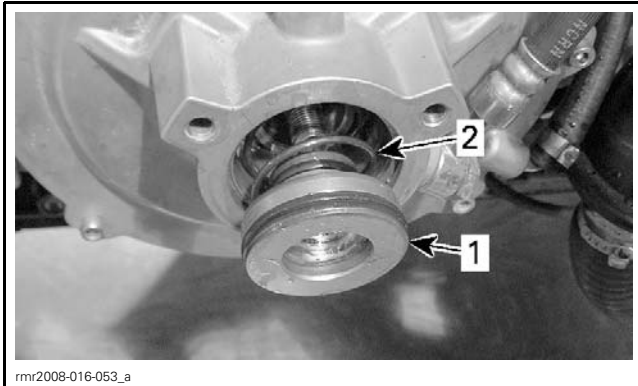

1. Hydraulic piston
2. Compression spring

Hydraulic Piston Inspection

Clean piston with new brake fluid.

Visually inspect piston surface for scoring, scratches or abnormal wear. Replace if necessary.

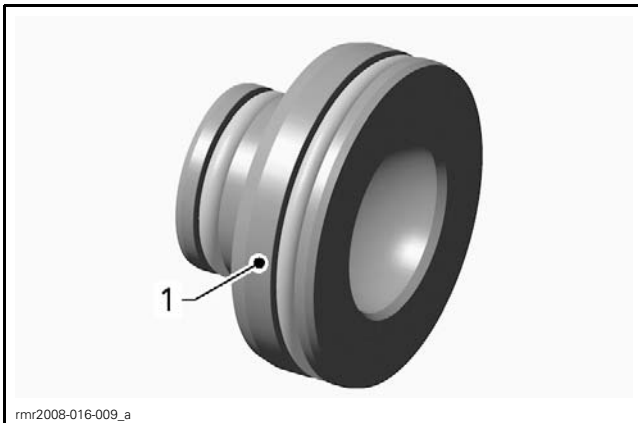

1. Check piston surface

Compression Spring

Check free length of compression spring.

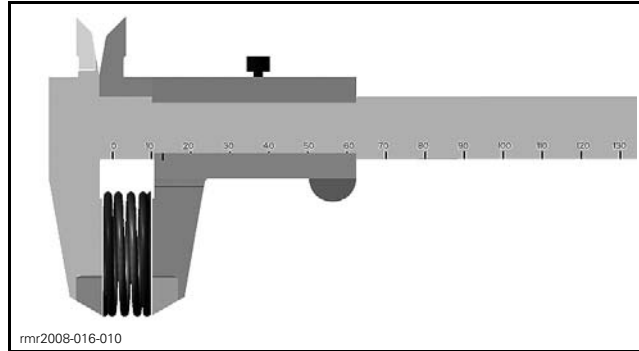

COMPRESSION SPRING FREE LENGTH

NEW	37.10 mm to 42.90 mm (1.461 in to 1.689 in)
SERVICE LIMIT	35.00 mm (1.378 in)

If the compression spring is out of specifications, replace it.

Hydraulic Piston Installation

Replace piston O-rings with **NEW** ones.

Coat hydraulic piston and O-rings with new brake fluid.

Install piston with compression spring into hydraulic cylinder.

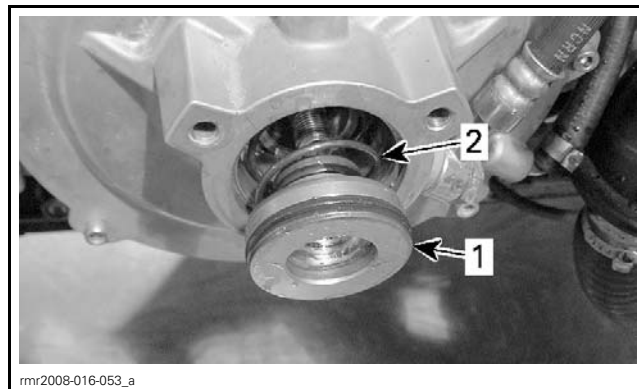

1. Hydraulic piston
2. Compression spring

Install hydraulic piston cover.

CLUTCH COVER

Clutch Cover Removal

Refer to *BODY* subsection and remove the following:

- Bottom rear side panel
- Rear side panel.

Lift and safely block RH front of vehicle to prevent engine oil leakage when removing components (if servicing clutch cover in vehicle).

Remove hydraulic piston cover screws.

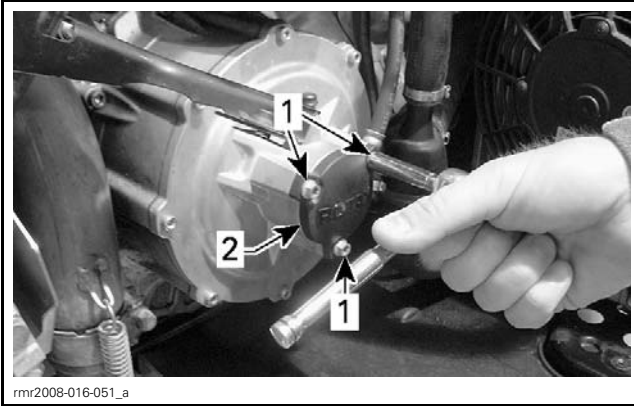

1. Screws
2. Hydraulic piston cover

Secure hydraulic piston with a large washer and a piston cover screw to retain the piston in the cylinder and avoid clutch fluid leakage.

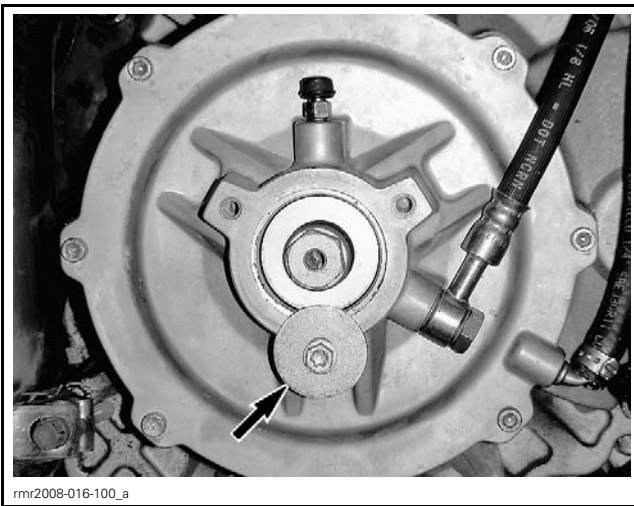

PISTON SECURED WITH A LARGE WASHER AND SCREW

Using a 17 mm deep offset wrench, unscrew the hydraulic piston nut while holding the clutch release shaft with a 5 mm Allen wrench. **The diaphragm must not twist.**

NOTICE Hold the clutch release shaft with the Allen wrench to avoid twisting and damaging the diaphragm.

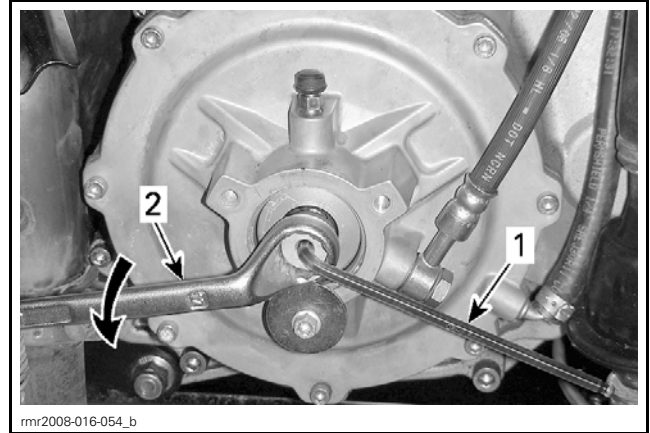

1. Hold Allen key
2. Turn wrench counterclockwise

Remove clutch cover retaining screws.

NOTE: Disconnect clutch fluid hose and vacuum hose **ONLY** if cover must be removed from the vehicle. Otherwise, omit these steps.

Loosen screw retaining clutch hose.

Disconnect hose and discard sealing washers.

NOTE: Install a drain pan under clutch hose to catch the clutch fluid.

Remove vacuum hose from clutch cover.

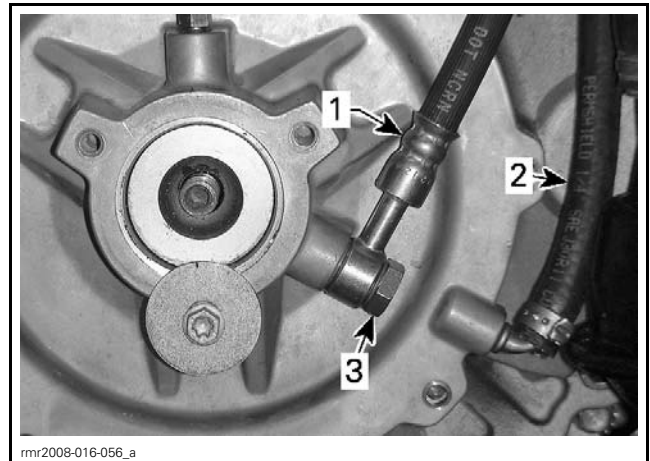

1. Clutch hose
2. Vacuum hose
3. Screw

Remove the clutch cover from the engine.

NOTICE Do not let the clutch cover hang from the hose and do not stretch or twist the hose.

Clutch Cover Inspection

Clean cover and check for cracks or other damage.

Clutch Cover Installation

Installation is the reverse of the removal procedure. However, pay attention to following details.

Subsection XX (CLUTCH (SM5))

Ensure slots in diaphragm are properly positioned on mounting lugs.



1. Mounting lug
2. Diaphragm slot inserted on lug

Install clutch cover.

Position cover so that clutch bleeder screw is pointing upwards (when engine is on vehicle).

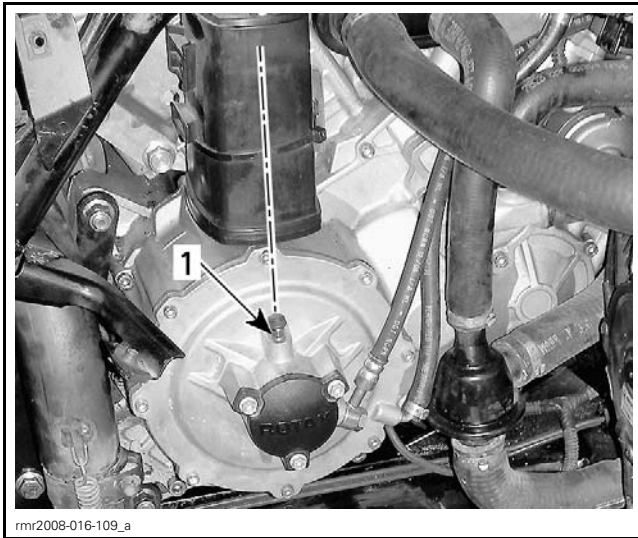

1. Bleeder approximately vertical

Torque clutch cover screws in a criss-cross pattern.

Install clutch fluid hose with **NEW** sealing washers.

Bleed clutch, refer to *CLUTCH BLEEDING PROCEDURES*.

Carry out a vacuum leak test. Refer to *CLUTCH OPERATION TEST*.

Screw the hydraulic piston nut **while holding release shaft** with a 5 mm Allen wrench. **The diaphragm must not twist.**

NOTICE Hold the clutch release shaft in its position using the Allen wrench to avoid twisting and damaging the diaphragm.

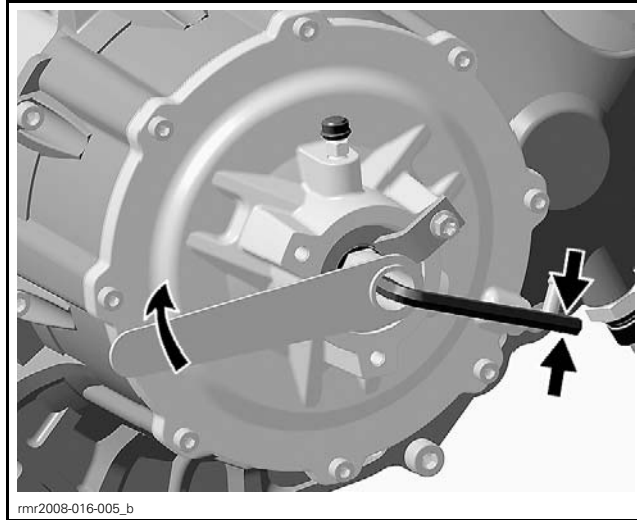

Torque the hydraulic piston nut to 15 N•m (133 lbf•in).

Test clutch operation.

Install hydraulic piston cover and torque screws.

NOTE: If clutch fluid leak occurred during cover removal, bleed and refill system as necessary.

HYDRAULIC CYLINDER

Hydraulic Cylinder Removal

Remove the *HYDRAULIC PISTON*. See procedure in this subsection.

Remove the *CLUTCH COVER*. See procedure in this subsection.

Remove the circlip retaining the hydraulic cylinder.

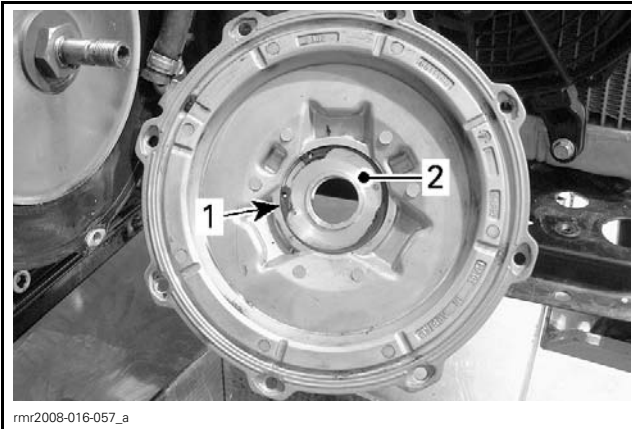

1. Circlip
2. Hydraulic cylinder

Remove hydraulic cylinder from clutch cover.

Hydraulic Cylinder Inspection

Clean parts with new brake fluid.

Visually inspect cylinder surface for scoring, scratches or abnormal wear. Replace if necessary.

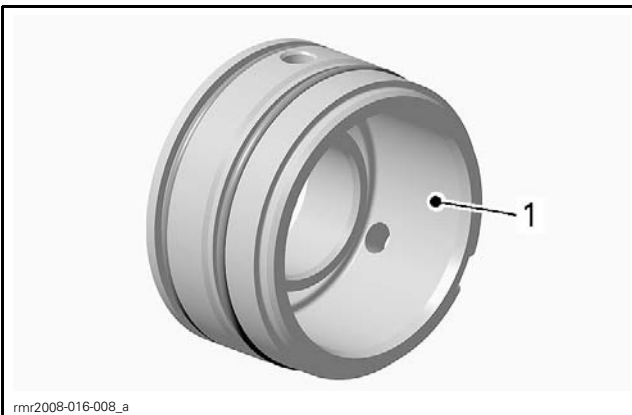

1. Inspect cylinder surface

Replace O-rings with **NEW** ones.

Also inspect the clutch cover bore for scoring, scratches or other damages.

Hydraulic Cylinder Installation

Coat hydraulic cylinder and O-rings with new brake fluid and install the cylinder into the clutch cover bore.

Ensure the notch in the cylinder is aligned with the embossment on the clutch cover. See next illustration.

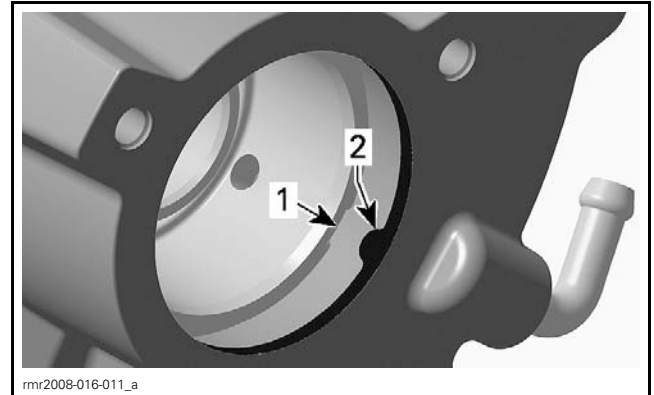

1. Hydraulic cylinder notch
2. Clutch cover embossment

Install cylinder retaining circlip.

CLUTCH DIAPHRAGM

Diaphragm Removal

Remove the *CLUTCH COVER*. See procedure in this subsection.

Pull diaphragm out of its mounting lugs, then rotate it away from the lugs to avoid damaging the diaphragm when removing retaining nut.



1. Mounting lugs
2. Diaphragm rotated out of lugs

Unscrew retaining nut while holding release shaft with a 5 mm Allen wrench.

Subsection XX (CLUTCH (SM5))



Remove thrust washer.
Remove disc plate.

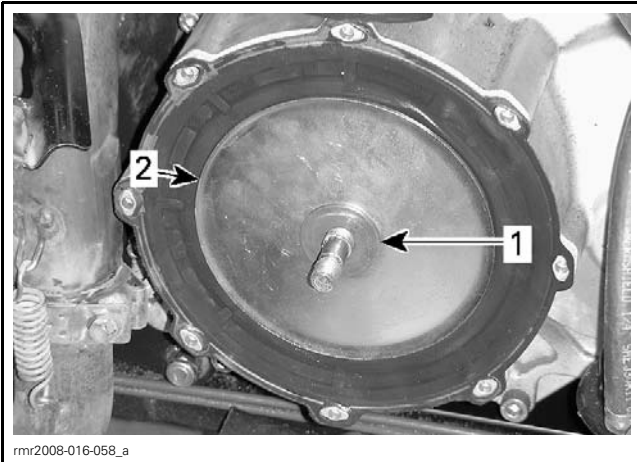

1. Thrust washer
2. Disc plate

Remove diaphragm.



Remove support disc.

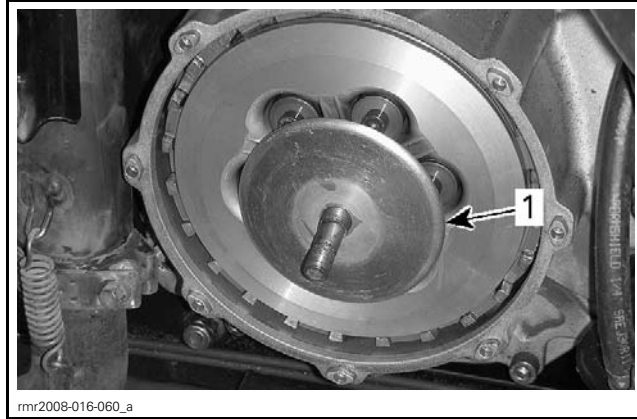

1. Support disc

Remove thrust washer.

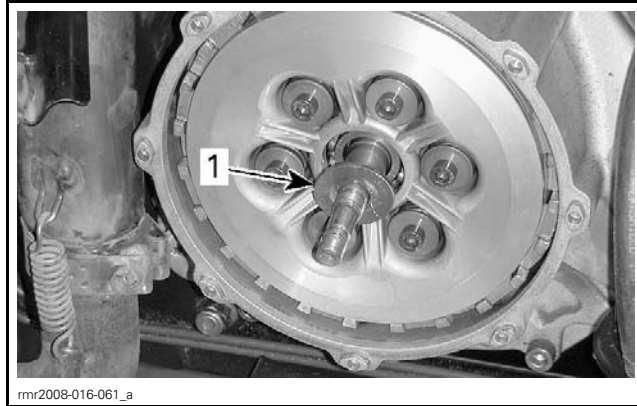

1. Thrust washer

Diaphragm Inspection

Inspect rubber diaphragm for wear, tears, or other damages. Replace if necessary.

Diaphragm Installation

Installation is the reverse of the removal procedure. However, pay attention to following details.

NOTICE Install support disc so that its rounded edge will be against diaphragm.

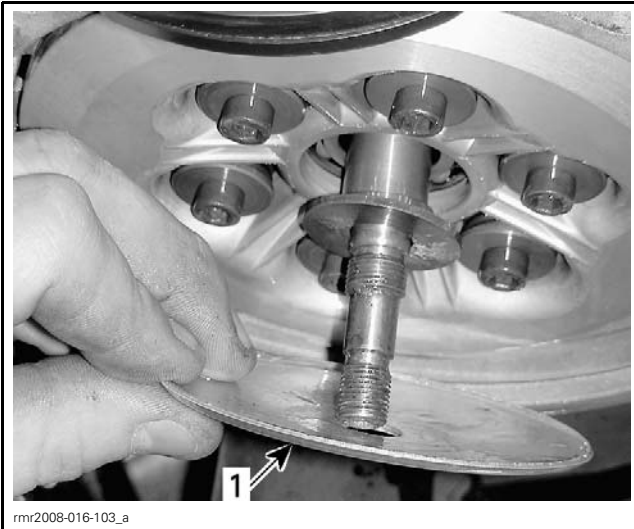

1. Rounded edge here

Ensure support disc is inserted past the groove in the shaft.

NOTE: Ensure to install the small support disc on the clutch side. The large disc plate goes on the outside of the diaphragm (clutch cover side).

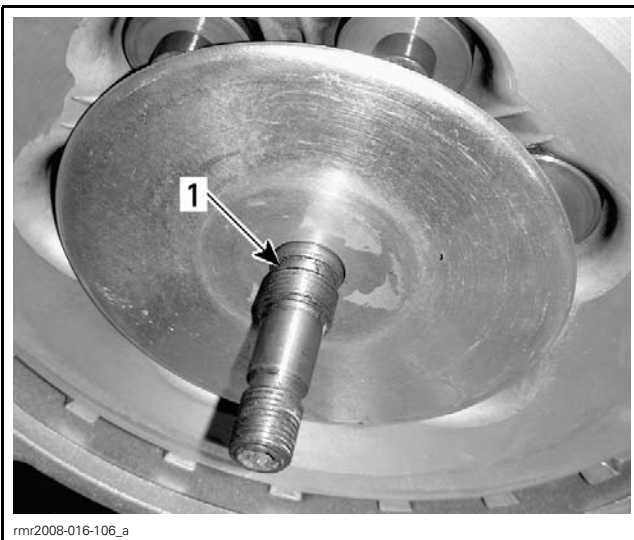

1. Groove

Install diaphragm.

NOTICE Do not install diaphragm into its mounting lugs yet.

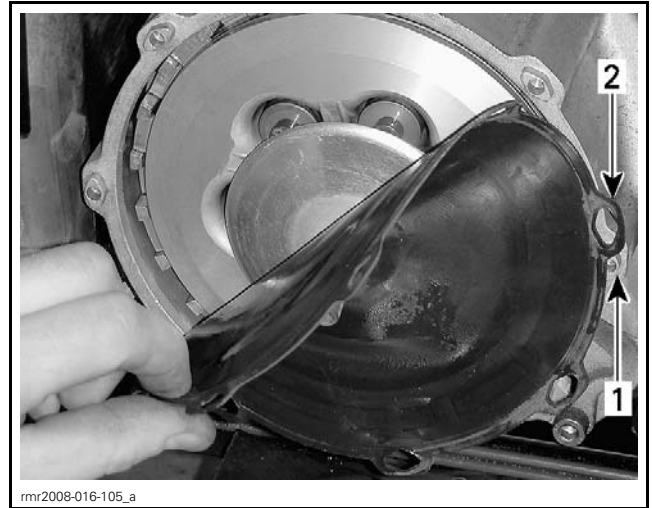

1. Mounting lug
2. Diaphragm out of lug

NOTICE Install disc plate so that its rounded edge will be against diaphragm.



1. Rounded edge here

Ensure diaphragm and disc plate are inserted past the groove in the shaft.

Subsection XX (CLUTCH (SM5))

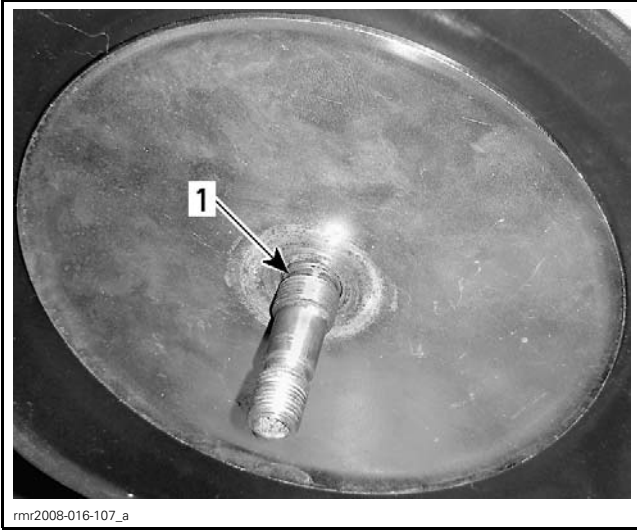

1. Groove

Apply LOCTITE 243 (BLUE) (P/N 293 800 060) on the retaining nut threads.

Install nut.

Tighten nut while holding release shaft with a 5 mm Allen wrench.



1. Mounting lug
2. Diaphragm slot inserted on lugs

Install clutch cover. Refer to *CLUTCH COVER*.

PRESSURE PLATE AND CLUTCH SPRINGS

Pressure Plate and Clutch Spring Removal

Remove *DIAPHRAGM*, see procedure in this subsection.

Loosen the retaining screws in a crisscross pattern, then remove them with the step washers.

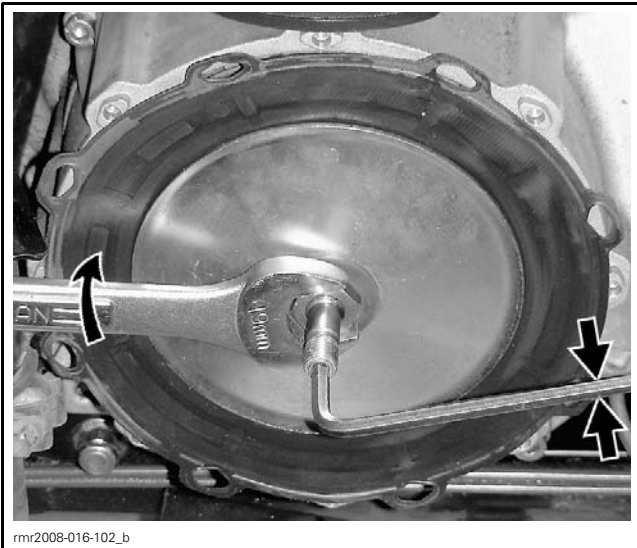

Torque nut to 15 N•m (133 lbf•in).

Position the slots in diaphragm onto the mounting lugs.

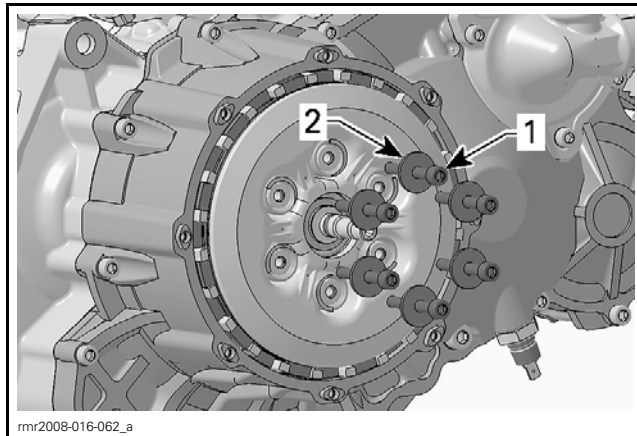

1. Retaining screw
2. Step washer

Remove clutch springs.

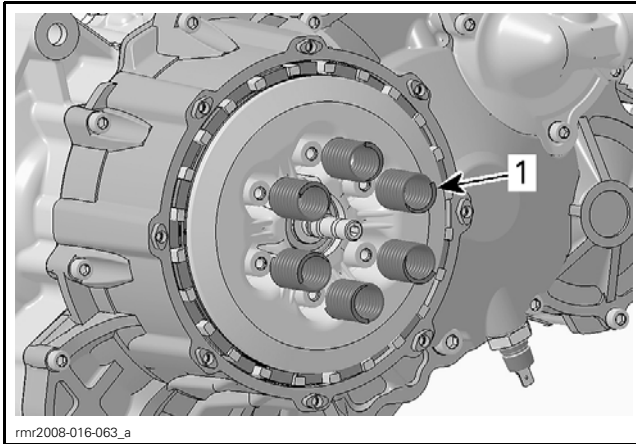

1. Clutch spring

Remove pressure plate.

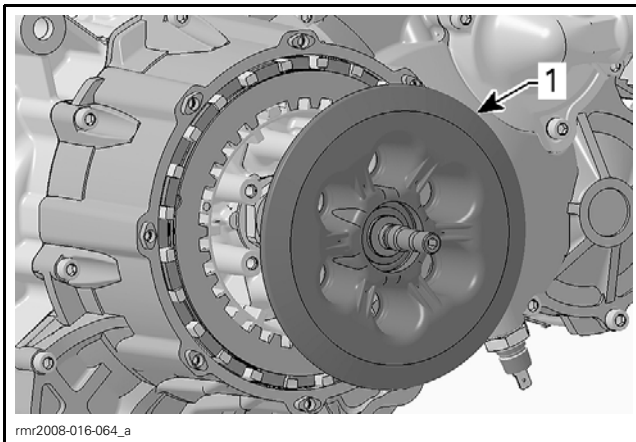

1. Pressure plate

Remove clutch release pin from pressure plate.

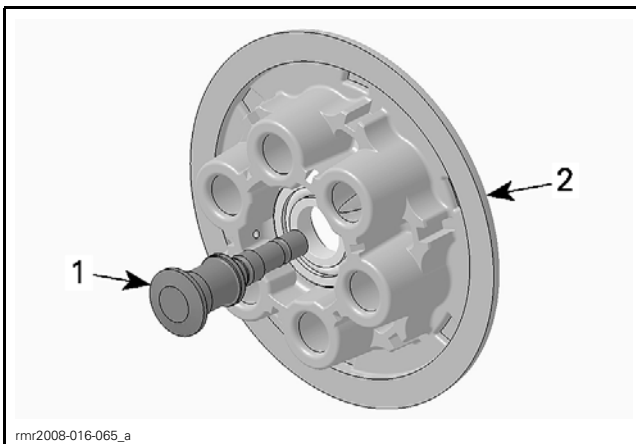

1. Clutch release pin
2. Pressure plate

Pressure Plate and Clutch Spring Inspection

Pressure Plate

Inspect pressure plate for cracks or other damages. Replace if necessary.

Check if bearing in pressure plate turns smoothly and freely. Replace if necessary.

Inspect thrust surface for wear or other damages.

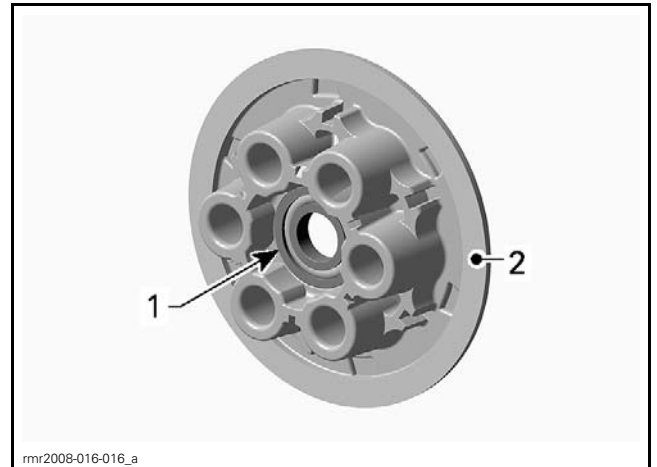

1. Bearing
2. Thrust surface

Clutch Spring

Measure each clutch spring free length. Replace every clutch spring if one is out of specifications.

CLUTCH SPRING FREE LENGTH	
SERVICE LIMIT	58.50 mm (2.303 in)

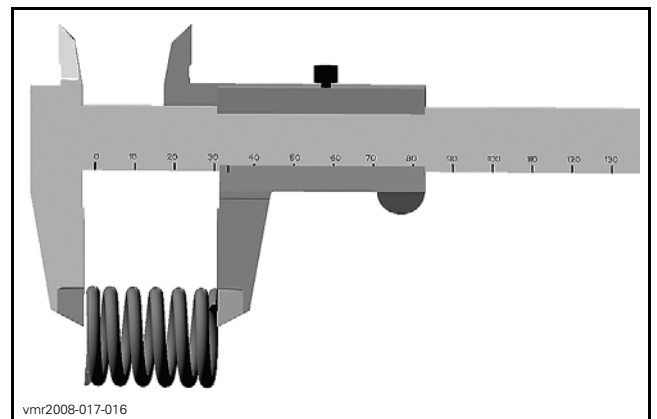

Clutch Release Pin

Visually inspect clutch release pin for wear or other damage. Replace if necessary.

Subsection XX (CLUTCH (SM5))

Pressure Plate and Clutch Spring Installation

For installation, reverse the removal procedure. However, pay attention to the following.

Tighten retaining screws in a crisscross pattern to 11 N•m (97 lbf•in).

CLUTCH PLATES

Clutch Plate Removal

Remove pressure plate. Refer to *PRESSURE PLATE AND CLUTCH SPRING* in this subsection.

Remove friction plates and steel driven plates.

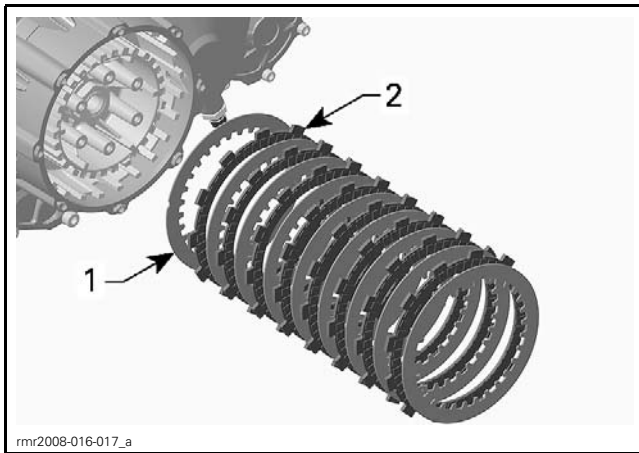

1. Friction plates
2. Steel driven plates

Clutch Plate Inspection

Inspect each plate for cracks, bent or broken teeth, missing or excessively worn friction material and any other damage.

Check friction and steel driven plates for warpage.

Place plates on a flat surface. Use a feeler gauge to measure warpage.

FRICTION AND STEEL DRIVEN PLATE WARPAGE	
SERVICE LIMIT	0.15 mm (.006 in)

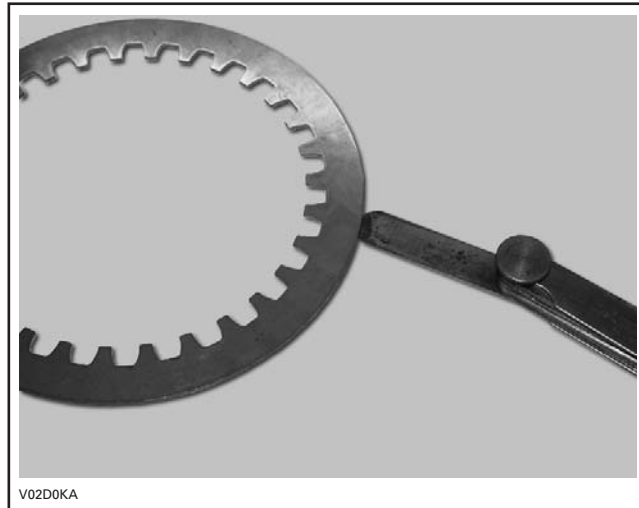

TYPICAL

Measure the thickness of the clutch plates assembly (friction and steel driven plates).

CLUTCH PLATES ASSEMBLY THICKNESS	
SERVICE LIMIT	45.00 mm (1.772 in)

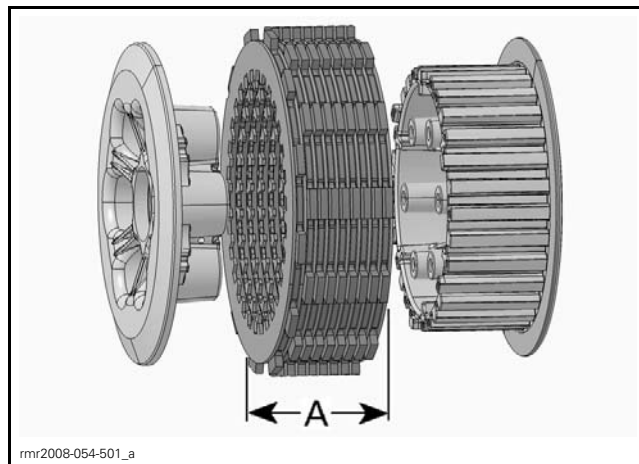

A. Service limit

If plates are warped, damaged, or worn out of tolerance, replace all clutch plates.

Clutch Plate Installation

For installation, reverse the removal procedure. However, pay attention to the following.

Thoroughly lubricate **NEW** clutch plates with engine oil before assembly to prevent clutch plates burning during break-in period.

First, install a hardened steel driven plate marked with a notch.

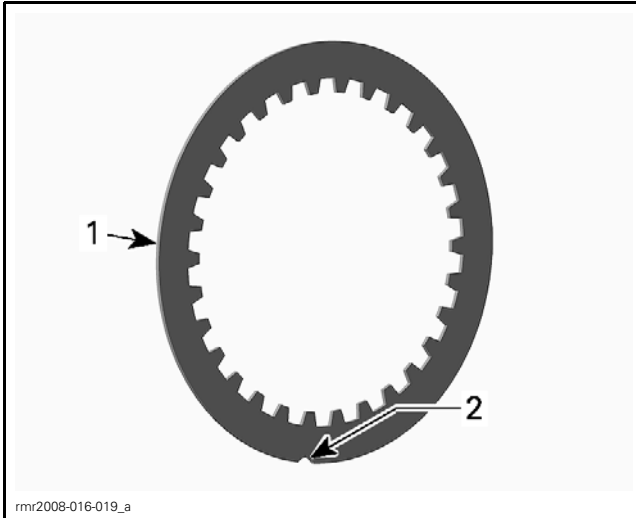

- 1. Hardened steel driven plate
- 2. Marked with notch

Then install friction plates and steel driven plates in alternate order.

Place the tabs of the last friction plate into the shorter slots in the clutch drum.

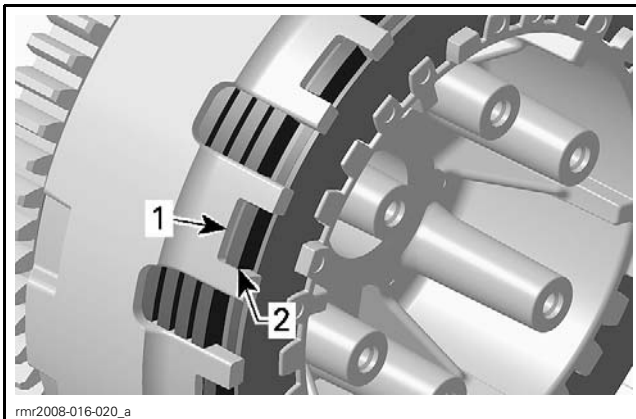

- 1. Shorter slot
- 2. Last friction plate

Reinstall remaining parts, refer to the applicable instructions.

CLUTCH HOUSING

Clutch Housing Removal

Engine Installed in Vehicle

Drain engine oil, refer to *LUBRICATION SYSTEM*.
 Drain engine coolant. Refer to *COOLING SYSTEM*.

Remove the bolt securing the top of the coolant radiator.

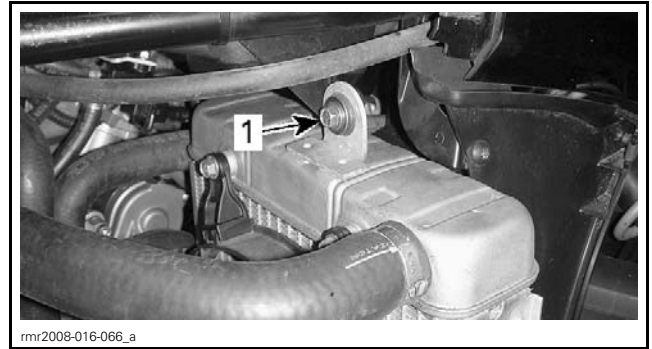

rnr2008-016-066_a

TYPICAL

- 1. Radiator mounting bolt

Remove water pump cover screws.

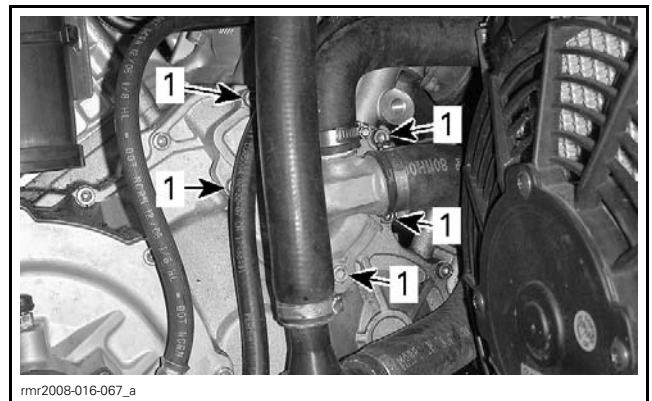

rnr2008-016-067_a

TYPICAL

- 1. Water pump cover screws

Move radiator rearward and unscrew the front engine mount bolt.

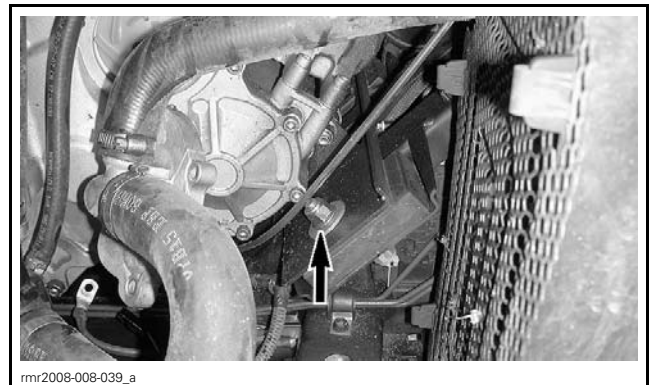

rnr2008-008-039_a

TYPICAL

Remove *DIAPHRAGM*. See procedure in this subsection.

Disconnect the oil pressure switch connector.

Subsection XX (CLUTCH (SM5))



1. Oil pressure switch connector

Remove the catalytic converter. Refer to *EX-HAUST SYSTEM* subsection.

Complete the clutch housing removal by following the steps detailed in *ENGINE REMOVED FROM VEHICLE*.

Engine Removed from Vehicle

Place a drain pan under the clutch housing to catch oil spillage.

Remove starter screws.

Remove all clutch housing screws.

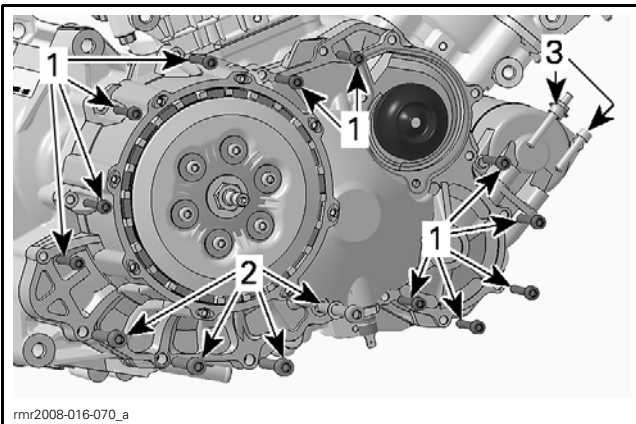

1. M6 retaining screws (11)
2. M8 retaining screws (4)
3. Starter screws

Remove the clutch housing. Gently tap on clutch housing using a soft hammer to separate it from the crankcase.

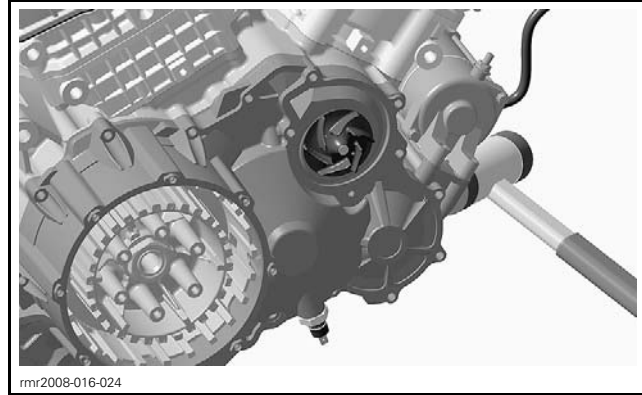

rnr2008-016-024

Clutch Housing Inspection

Inspect the clutch housing for cracks or other damages. Replace if necessary.

Check sealing surface for flatness.

Clean oil orifices in clutch housing from contaminants using PULLEY FLANGE CLEANER (P/N 413 711 809), then use an air gun to dry it.

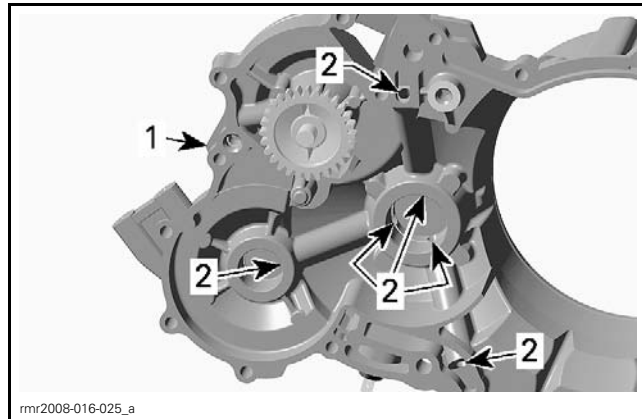

1. Clutch housing
2. Clean oil bores

Inspect plain bearings for scoring or other damages.

Measure plain bearing inside diameters and compare to the crankshaft and balance shaft journal diameters (support bearings). Refer to *BOTTOM END* subsection. Replace if measurement is out of specification.

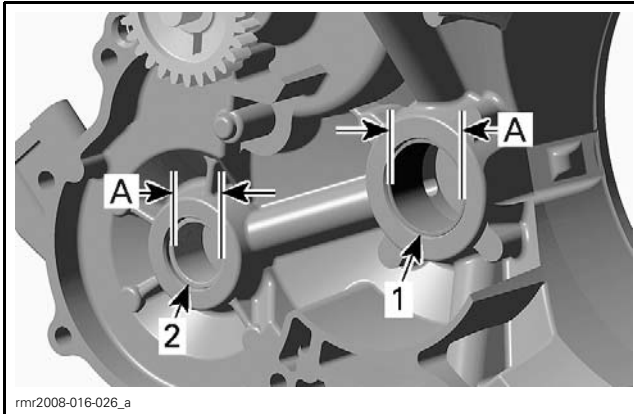

- 1. Plain bearing (crankshaft support)
- 2. Plain bearing (balance shaft support)
- A. Measure plain bearing inside diameter

SERVICE LIMIT OF PLAIN BEARING INSIDE DIAMETER	
Crankshaft support bearing	30.040 mm (1.1827 in)
Balance shaft support bearing	20.060 mm (.7898 in)

Plain Bearing Replacement in Clutch Housing

Plain Bearing Removal

Mark the joint locations of the plain bearing segments on the clutch housing, prior to removing the plain bearings.

Pull out the plain bearings using the BLIND HOLE BEARING PULLER SET (P/N 529 036 117).

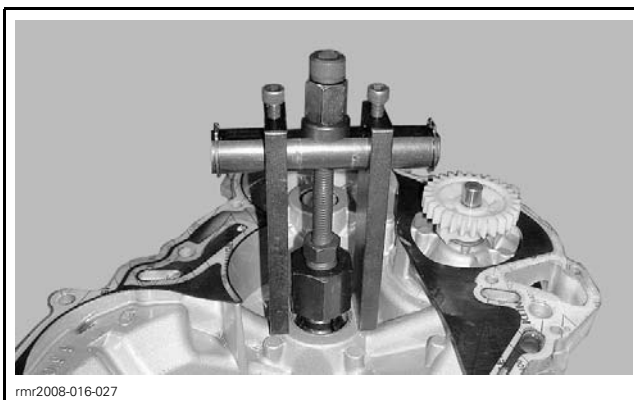

Plain Bearing Installation

Crankshaft support plain bearings are available in 3 tolerance groups (red, blue and yellow). The proper tolerance group is marked with paint on the clutch housing.

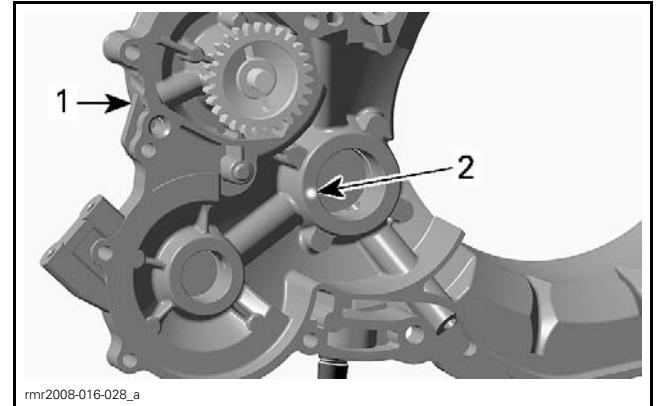

- 1. Clutch housing
- 2. Paint marking of tolerance group

If paint marking is not visible anymore, measure inside diameter of clutch housing bore where plain bearings are inserted.

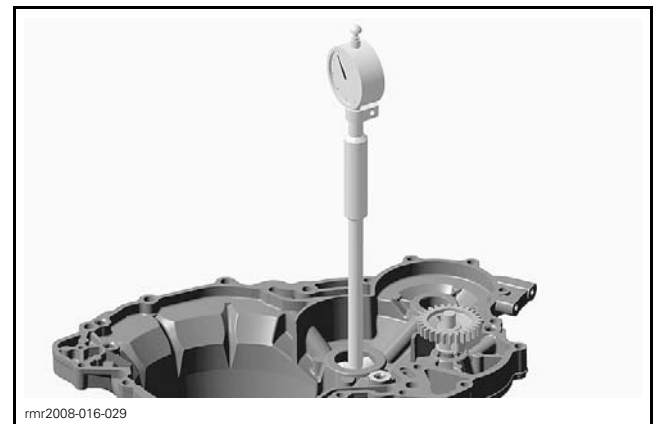

MEASURE CLUTCH HOUSING BORE DIAMETER

Use the following table to find proper tolerance group of plain bearing.

CLUTCH HOUSING BORE DIAMETER	PLAIN BEARING TOLERANCE GROUP
32.921 mm to 32.930 mm (1.2961 in to 1.2965 in)	Red
32.930 mm to 32.940 mm (1.2965 in to 1.2969 in)	Blue
32.940 mm to 32.951 mm (1.2969 in to 1.2973 in)	Yellow

NOTICE Unless otherwise instructed, never use a hammer to install plain bearings. Plain bearings should only be installed using a press.

Heat clutch housing up to 100°C (212°F) before installing plain bearings.

Install plain bearings using the appropriate plain bearing installer.

Subsection XX (CLUTCH (SM5))

PLAIN BEARING	SERVICE TOOL PART NUMBER
Crankshaft support bearing	529 036 095
Balance shaft support bearing	529 036 096

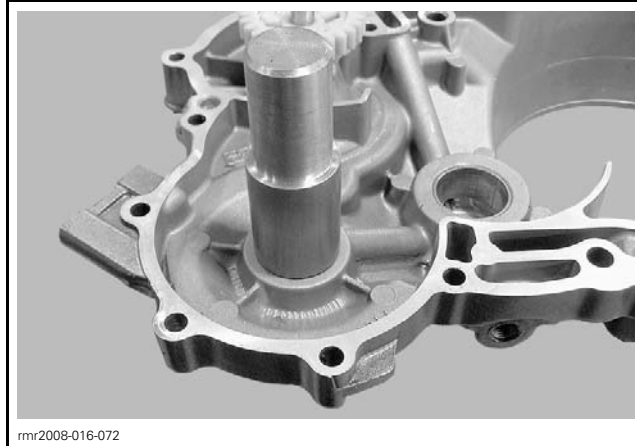
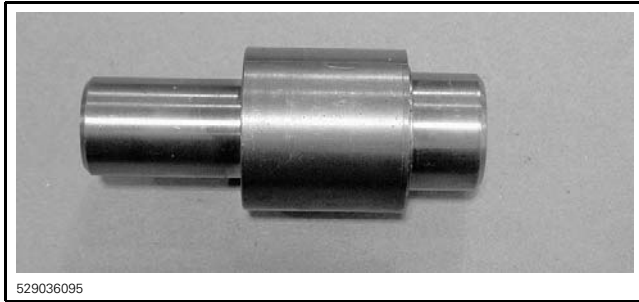

PLAIN BEARING INSTALLER — BALANCE SHAFT SUPPORT BEARING

Fit the plain bearings with PETAMO GREASE GHY 133N (P/N 420 899 271).

Support the clutch housing with a suitable support under the bearing seat. Use an O-ring to hold the plain bearings together during installation. Then carefully press-in the plain bearings.

NOTE: Remove O-ring just before plain bearings are completely pressed in.

NOTICE The plain bearing segments must be positioned as marked during removal.

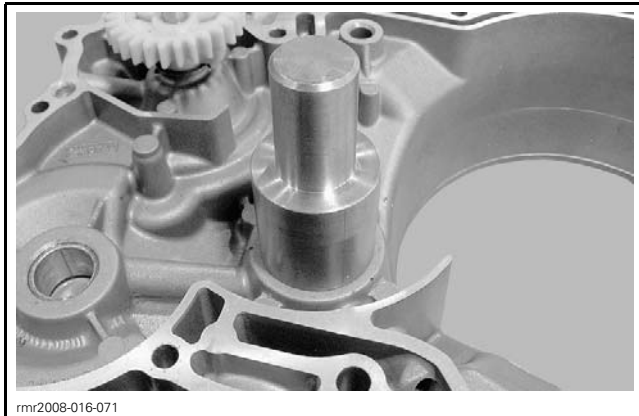

PLAIN BEARING INSTALLER — CRANKSHAFT SUPPORT BEARING

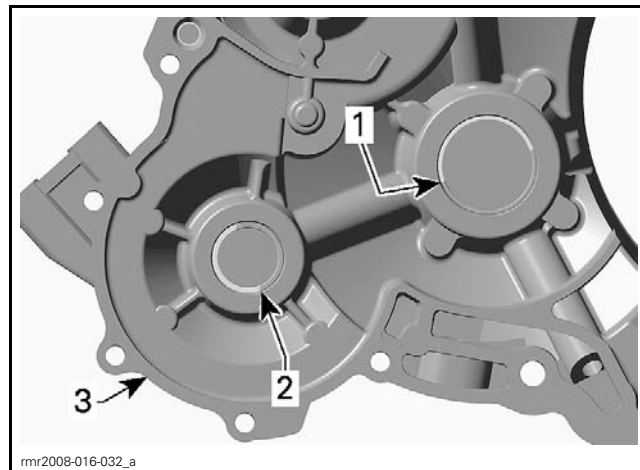
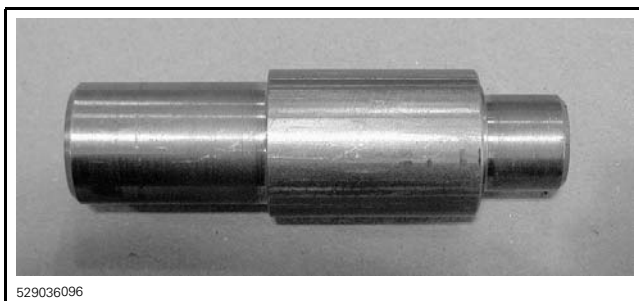

1. Partition of crankshaft support plain bearing
2. Partition of balance shaft support plain bearing
3. Clutch housing

Clutch Housing Installation

For installation, reverse the removal procedure. However, pay attention to the following.

Install a **NEW** clutch housing gasket and **NEW** sealing washers.

Lubricate plain bearings with PETAMO GREASE GHY 133N (P/N 420 899 271), before installing clutch housing.

Torque clutch housing screws using crisscross pattern.

Reinstall remaining parts, refer to the appropriate instructions.

CLUTCH HUB

Clutch Hub Removal

Remove:

- Clutch cover
- Clutch plates.

See procedures in this subsection.

Lock crankshaft in TDC position, refer to *CRANKCASE AND CRANKSHAFT*.

Install CLUTCH ASSEMBLY HOLDER (P/N 529 035 618).

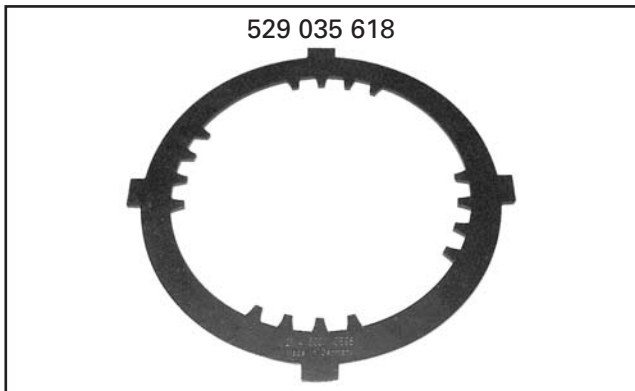

Remove the clutch hub locking nut and spring washer.

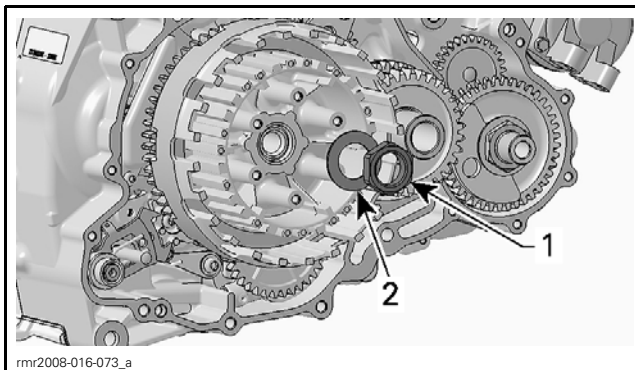

1. Clutch hub locking nut
2. Spring washer

Remove clutch hub.

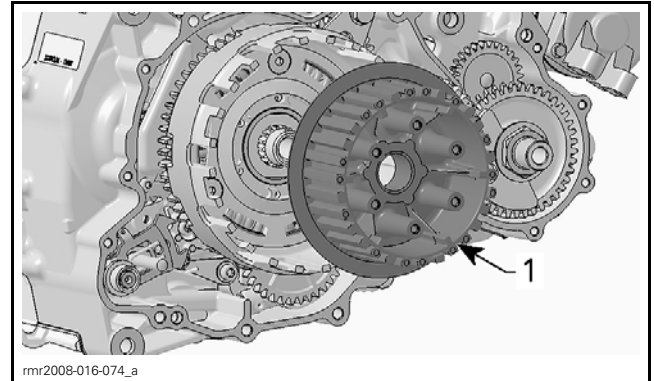

1. Clutch hub

Clutch Hub Inspection

Inspect grooves in clutch hub for damages or wear caused by steel driven plates. Replace if necessary.

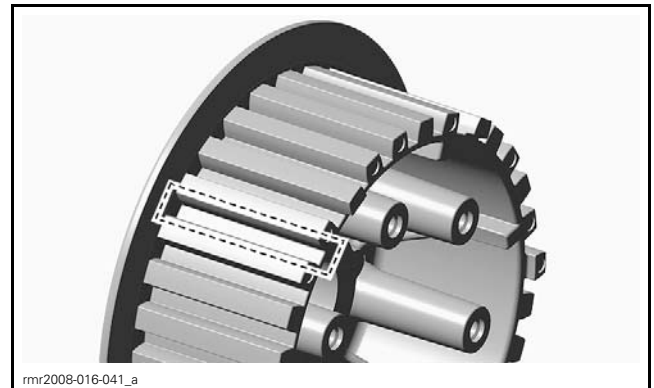

INSPECT GROOVES IN CLUTCH HUB FOR WEAR

Clutch Hub Installation

Ensure clutch drum thrust washer is installed on clutch shaft ahead of clutch drum assembly before installing the clutchhub.

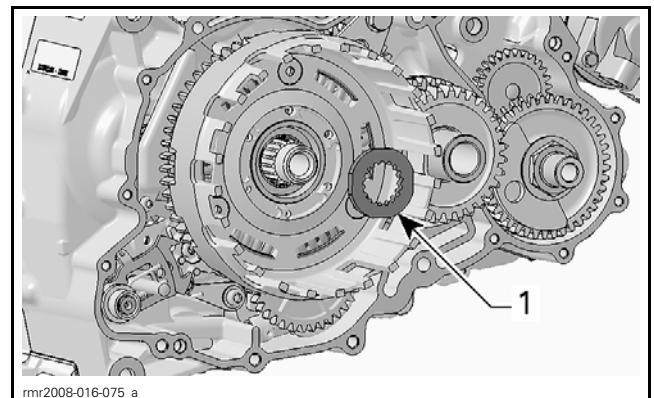

1. Clutch drum thrust washer

Apply PETAMO GREASE GHY 133N (P/N 420 899 271) on clutch hub teeth.

Insert clutch hub.

Subsection XX (CLUTCH (SM5))

Reinstall spring washer and hub retaining nut.

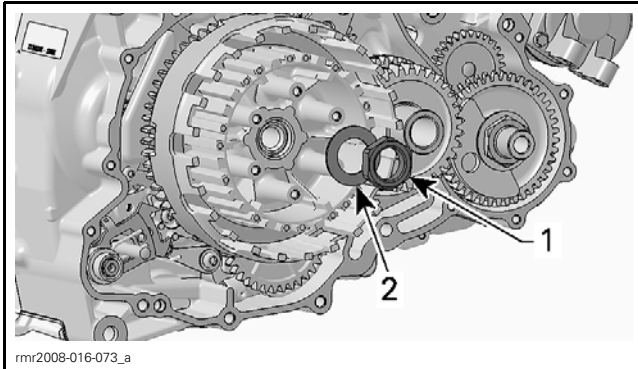

1. Clutch hub retaining nut
2. Spring washer

Apply LOCTITE 648 (GREEN) (P/N 413 711 400) on hub retaining nut threads.

Torque nut to 190 N•m (140 lbf•ft).

Reinstall remaining parts, refer to the appropriate instructions in this subsection.

CLUTCH DRUM

Clutch Drum Removal

Remove the following items, see procedures in this subsection.

- Clutch cover
- Clutch disk assembly
- Clutch hub
- Clutch housing.

Remove the clutch drum thrust washer.

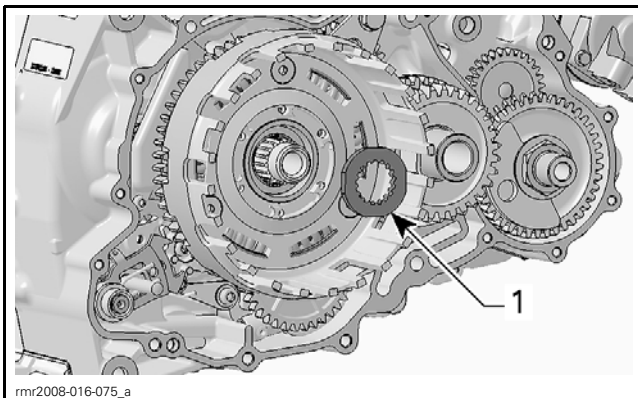

1. Clutch drum thrust washer

Remove the clutch drum.

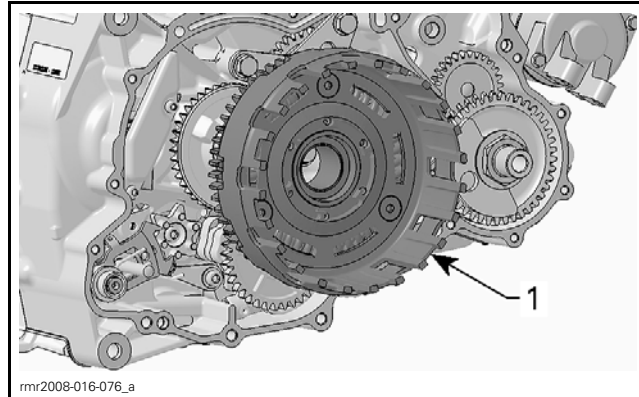

1. Clutch drum

Clutch Drum Disassembly

Remove the oil pump drive gear.

Remove retaining nuts.

Remove the outer support plate.

Remove distance sleeves.

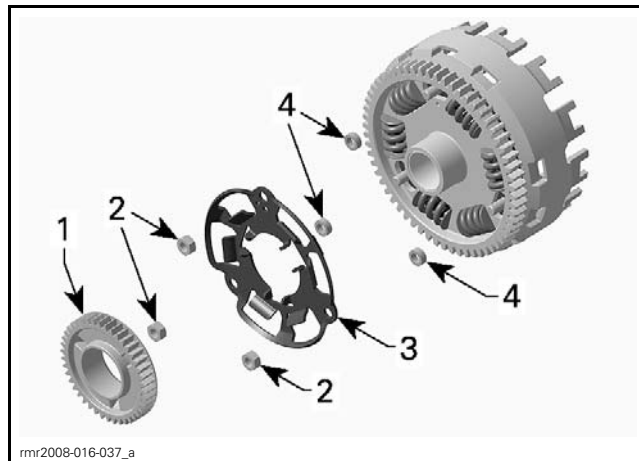

1. Oil pump drive gear
2. Retaining nuts
3. Outer support plate
4. Distance sleeves

NOTE: Mark the position of springs and retainers, prior to removing them.

Remove clutch drum and gear together as well as both white marked springs and their spring retainers.

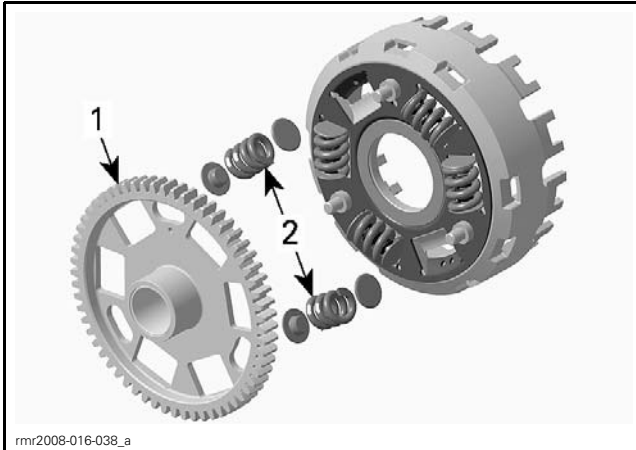

1. Clutch drum gear
2. Springs with white marks

Remove all other springs with their spring retainers.

Remove the disc spring.

Remove the thrust washer.

Remove the inner support plate.

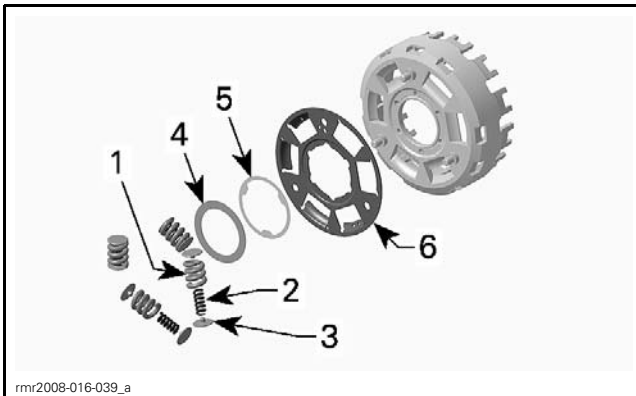

1. Outer compression springs
2. Inner compression springs
3. Spring retainers
4. Disc spring
5. Thrust washer
6. Inner support plate

Clutch Drum Inspection

Compression Springs and Retainers

Measure free length of each compression spring, refer to the following table.

COMPRESSION SPRING FREE LENGTH	
SERVICE LIMIT	
Outer springs and white marked springs	26.75 mm (1.053 in)
Inner springs	25.65 mm (1.01 in)

If a spring is out of specification, replace all springs as well as all spring retainers.

Inspect spring retainers for wear, cracks or scoring. Replace all springs and all spring retainers as an assembly.

Support Plates

Inspect support plates for cracks or abnormal wear. Replace if necessary.

Inspect the thrust surface of inner support plate for abnormal wear or grooves. If necessary, replace inner support plate, thrust washer and disc spring as an assembly.

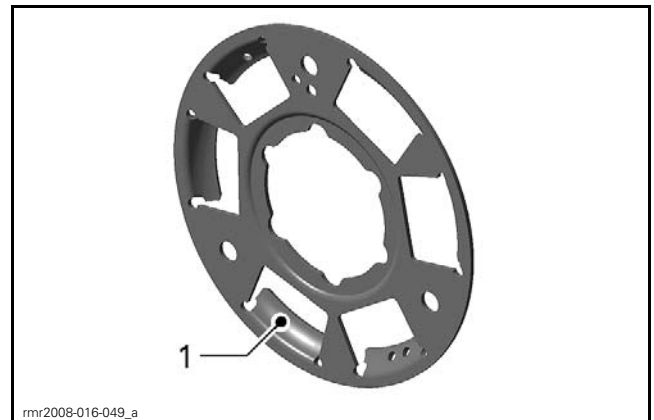

1. Inspect thrust surface of inner support plate

Clutch Drum Gear

Inspect bearing sleeve for scoring and wear.

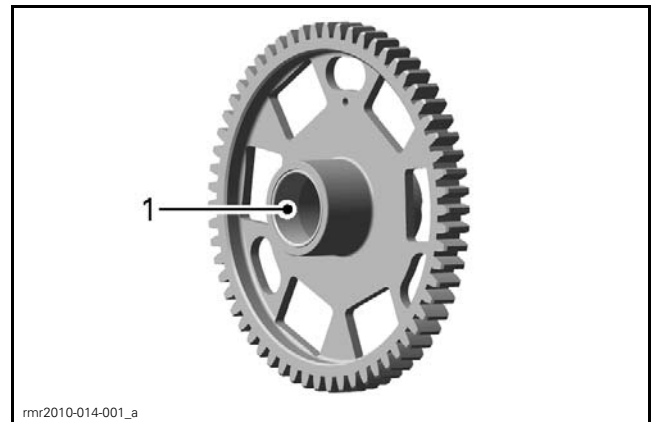

1. Bearing sleeve surface

Measure inner diameter of bearing sleeve.

Subsection XX (CLUTCH (SM5))

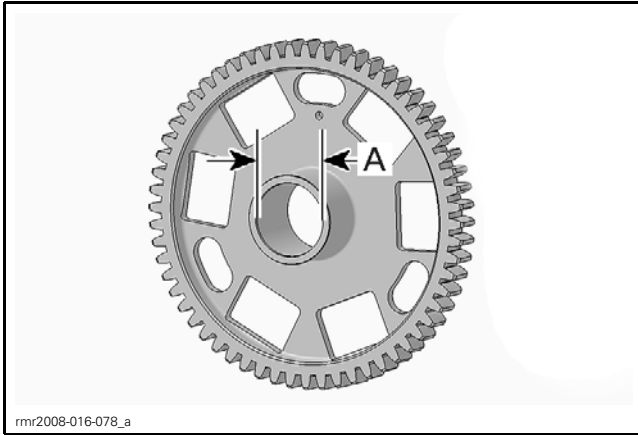

A. Inner diameter

BEARING SLEEVE INNER DIAMETER	
SERVICE LIMIT	30.060 mm (1.183 in)

Inspect teeth condition for pitting or other damage.

Replace clutch drum gear with drive gear if necessary.

Clutch Drum

Inspect slots in clutch drum for damages or wear caused by friction plates. Replace if necessary.

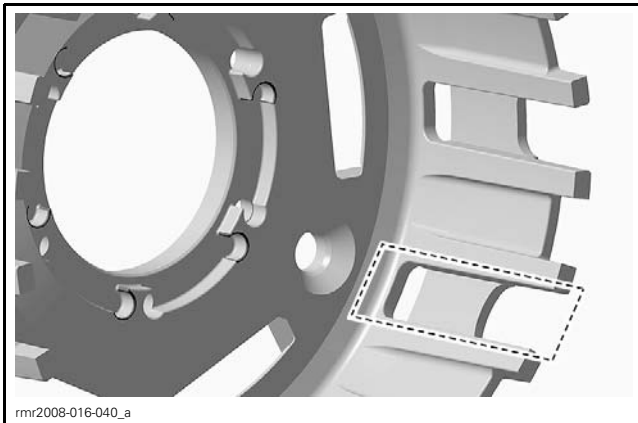

INSPECT SLOTS IN CLUTCH DRUM FOR WEAR

Inspect spring cavities for deep grooves caused by springs. Replace clutch drum if necessary.

NOTE: Slight markings caused by the springs are normal. Do not replace clutch drum needlessly.



1. Inspect spring cavity

Clutch Drum Assembly

NOTICE Assembly of the clutch drum must be carried out with the utmost care. Failure to strictly follow procedures may cause parts to loosen and/or malfunction of the clutch drum and may lead to serious engine damage.

Assemble the clutch drum in the reverse order of disassembly. However, pay attention to the following details.

NOTICE The position of the clutch drum, support plates and clutch drum gear for assembly is clearly indicated with location holes in each part. During assembly, ensure that all location holes are aligned with each other.

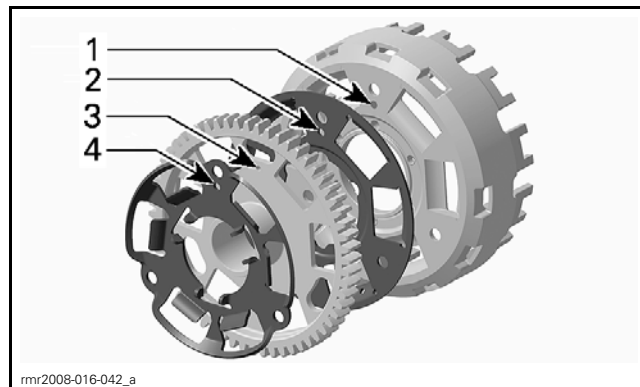

ALIGNMENT OF LOCATION HOLES OF CLUTCH DRUM PARTS

1. Hole in clutch drum
2. Hole in inner support plate
3. Hole in clutch drum gear
4. Hole in outer support plate

Insert the three M8 X 25 flat head screws from the inside of the drum. Hold the screws in position as you install the remaining parts.

Install inner support plate on clutch drum, ensure the location holes are aligned with each other.

Install **NEW** disc spring with the concave side facing the inner support plate.

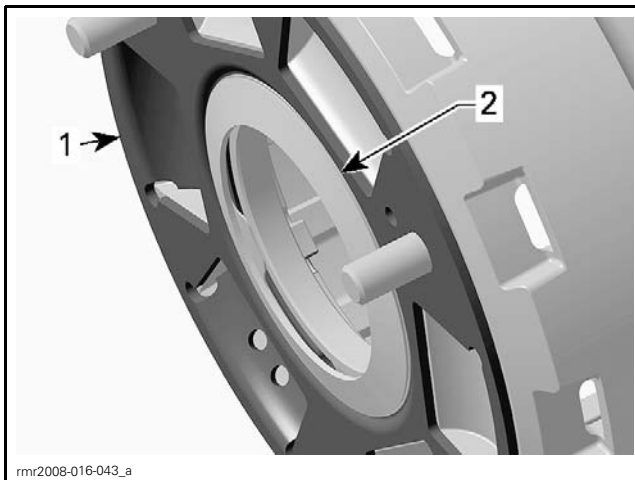

1. Support plate
2. Disc spring

Install the clutch drum gear, ensure the location holes are aligned with each other.

Install both white marked springs with spring retainers into the corresponding spring cavities which are marked with punched holes inside the inner support plate.

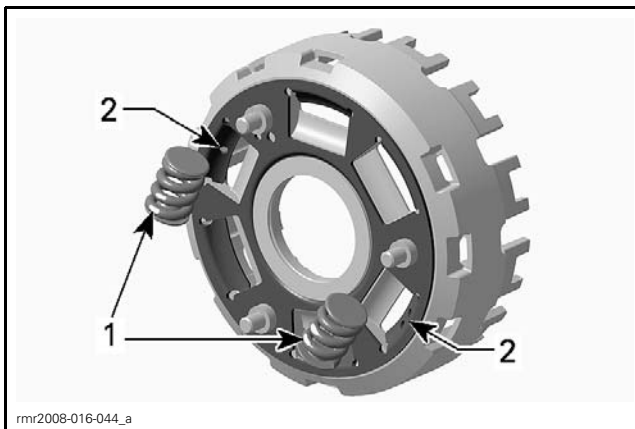

1. White marked springs
2. Spring cavities marked with punched holes

Install remaining springs and retainers into spring cavities.

Install distance sleeves on clutch drum screws, then outer support plate. Ensure that the location holes are aligned with each other.

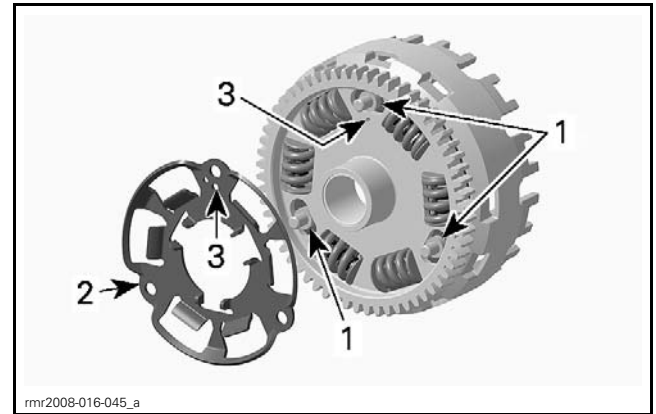

1. Distance sleeves
2. Outer support plate
3. Location holes

Install retaining nuts on clutch drum screws.

Apply LOCTITE 648 (GREEN) (P/N 413 711 400) on threads of retaining nuts.

Torque nuts to 30 N•m (22 lbf•ft).

Finally install oil pump gear. Ensure that tabs of oil pump gear engage in cavities of outer support plate.

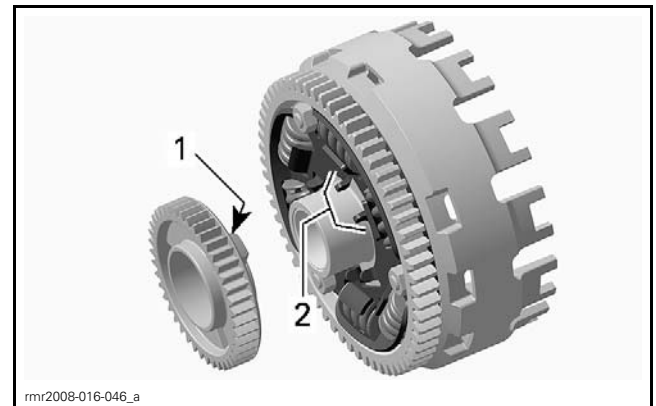

1. Tabs of oil pump gear
2. Cavities of outer support plate

Functional Test

After assembly of the clutch drum is complete, check for torsion of the clutch drum on clutch drum gear by doing the following.

- Reinstall clutch drum on clutch shaft.
- Ensure crankshaft is locked at piston TDC.
- Try to turn clutch drum.

There must be no free-play between clutch drum and clutch drum gear.

If free-play has been detected, inspect all clutch drum components (e.g. disk spring, thrust washer, inner support plate). Refer to *CLUTCH DRUM INSPECTION* in this subsection.

Subsection XX (CLUTCH (SM5))

Clutch Drum Installation

For installation, reverse the removal procedure. However, pay attention to the following.

Insert the first thrust washer on the clutch shaft.

Insert clutch drum on the clutch shaft.

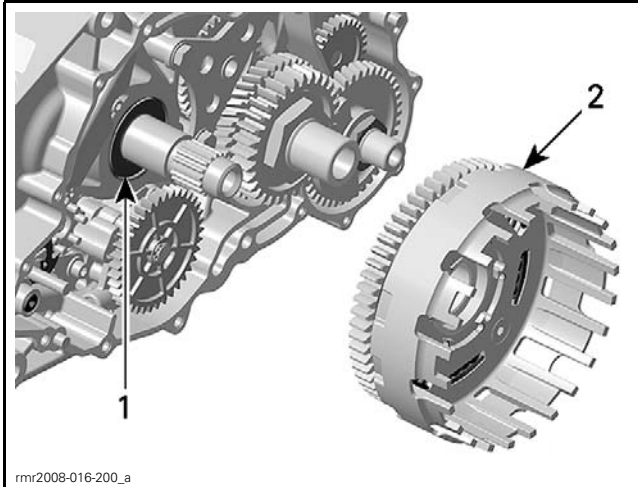

1. Thrust washer
2. Clutch drum

Install the other thrust washer on clutch shaft.

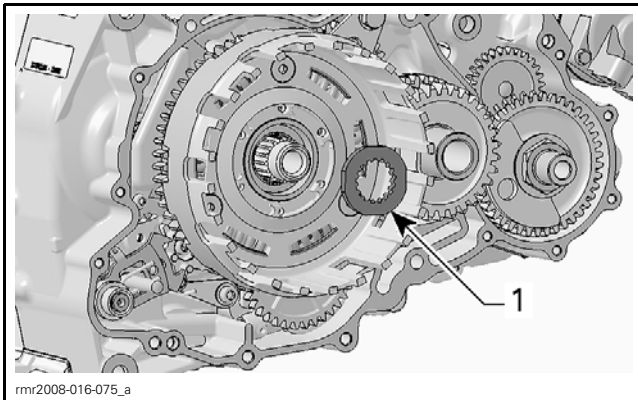

1. Thrust washer

Install clutch hub and all remaining parts. See procedures in this subsection.