

Date: **February 14, 2007**

Subject: **Outlander™ V-twin EFI Models  
Heat Shield**

No. **2007-10**

YEAR	MODEL	MODEL NUMBER	SERIAL NUMBER
2006-2007	Outlander™ V-twin EFI models	All	All

New 2007 Renegade models use a new heat shield design different than the one used originally on all Outlander V-twin EFI models.

Due to standardization, Outlander V-twin EFI models will now use this same design from factory starting mid-January production, including MAX models.

Furthermore, the new heat shield design can retrofit Outlander V-twin EFI models built with the original design and heat shield update kits are available as service parts.

Heat shield update kits should be installed preventively solely on vehicles being ran with an Apache track kit or in one of the following particularly severe conditions:

- farm or commercial application (mowing)
- heavy load pulling
- snow plowing
- extensive low speed riding or idling

Normal warranty applies.

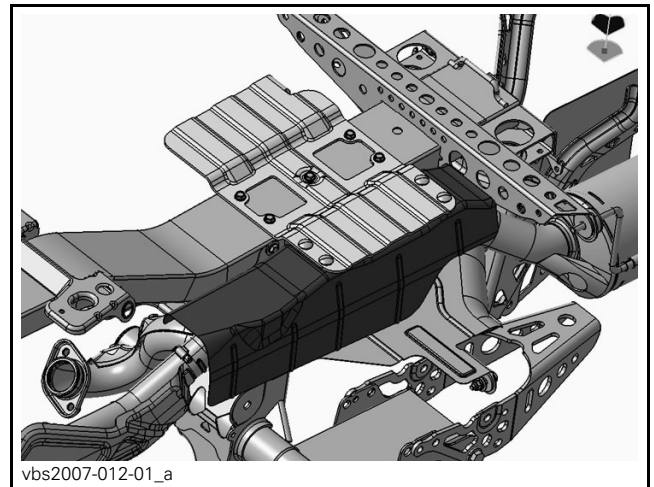

<b>Outlander V-twin EFI models</b>	<b>(P/N 703 500 708)</b>
------------------------------------	--------------------------

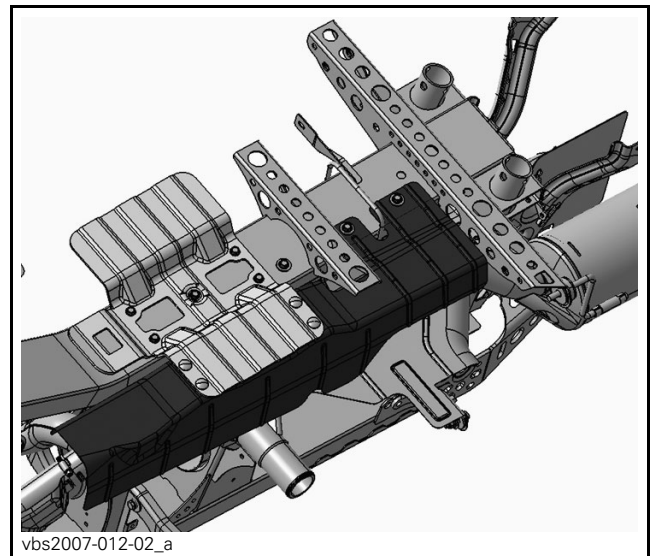

<b>Outlander MAX V-twin EFI models</b>	<b>(P/N 703 500 709)</b>
--	--------------------------